

DECORATIVE VENTILATION FAN WITH LIGHT



READ AND SAVE THESE INSTRUCTIONS

WARNING

TO REDUCE THE RISK OF FIRE, ELECTRIC SHOCK, OR INJURY TO PERSONS, OBSERVE THE FOLLOWING:

1. Use this unit only in the manner intended by the manufacturer. If you have questions, contact the manufacturer at the address or telephone number listed in the warranty.
2. Before servicing or cleaning unit, switch power off at service panel and lock the service disconnecting means to prevent power from being switched on accidentally. When the service disconnecting means cannot be locked, securely fasten a prominent warning device, such as a tag, to the service panel.
3. Installation work and electrical wiring must be done by a qualified person(s) in accordance with all applicable codes and standards, including fire-rated construction codes and standards.
4. Sufficient air is needed for proper combustion and exhausting of gases through the flue (chimney) of fuel burning equipment to prevent backdrafting. Follow the heating equipment manufacturer's guideline and safety standards such as those published by the National Fire Protection Association (NFPA), and the American Society for Heating, Refrigeration and Air Conditioning Engineers (ASHRAE), and the local code authorities.
5. When cutting or drilling into wall or ceiling, do not damage electrical wiring and other hidden utilities.
6. Ducted fans must always be vented to the outdoors.
7. NEVER place a switch where it can be reached from a tub or shower.
8. This unit must be grounded.
9. This unit is U.L. listed. Type I.C. Inherently protected.

CAUTION

1. For general ventilating use only. Do not use to exhaust hazardous or explosive materials and vapors.
2. This product is designed for installation in FLAT CEILINGS ONLY. Do not mount this product in a wall.
3. The light fixture assembly must be mounted to the fan housing assembly included with this product. Do not mount the light fixture assembly to a wiring outlet box.
4. To avoid motor bearing damage and noisy and/or unbalanced impellers, keep drywall spray, construction dust, etc. off power unit.
5. Please read specification label on product for further information and requirements.

Installer:
Leave this manual with the homeowner.

Homeowner:
Use and Care information on page 4.

TYPICAL INSTALLATIONS

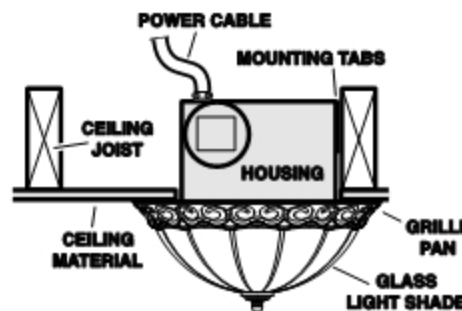

HOUSING MOUNTED DIRECTLY TO JOIST
2x6 (or larger)
Discharge parallel to joists.

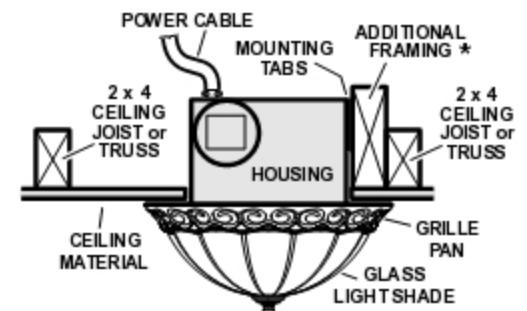

HOUSING MOUNTED TO 2x4 TRUSS
Requires additional framing for mounting tabs.
Discharge parallel to joists.

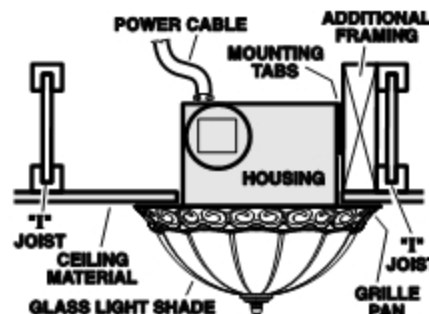

HOUSING MOUNTED TO "1" JOIST
Requires additional framing for mounting tabs.
Discharge parallel to joists.

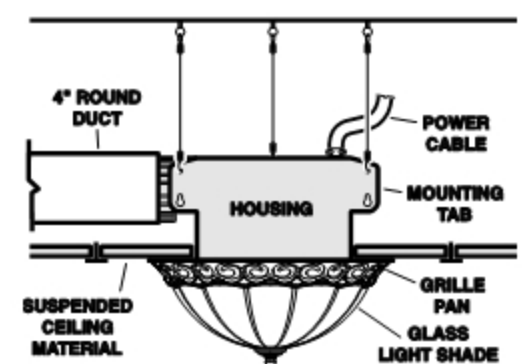

SUSPENDED CEILINGS
Housing hung with wires - 3-point mount.

* Additional framing must be a 2x6 (minimum height), at least 9-inches long.

PLAN THE INSTALLATION

The unit will operate most quietly and efficiently when located where the shortest possible duct run and minimum number of elbows will be needed.

Use a roof cap or wall cap that has a built-in damper to reduce backdrafts.

Plan to supply the unit with proper line voltage and appropriate power cable.

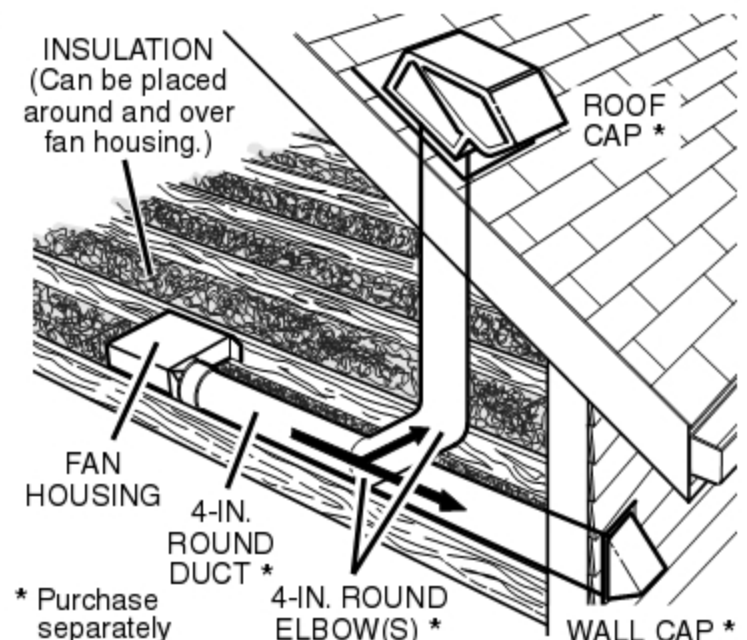

* Purchase separately

INSTALL THE HOUSING

- PLEASE NOTE -

THE FOLLOWING INSTALLATION ILLUSTRATIONS SHOW 2 X 6 JOISTS. IF YOU HAVE A TRUSS OR "I"-JOIST INSTALLATION, MOUNT THE VENTILATOR TO THE ADDITIONAL FRAMING IN THE SAME MANNER. (Additional framing must be a 2x6 (minimum height), at least 9-inches long.)

New Construction

1. Choose the location for your fan in the ceiling. For best possible performance, use the shortest possible duct run and a minimum number of elbows.

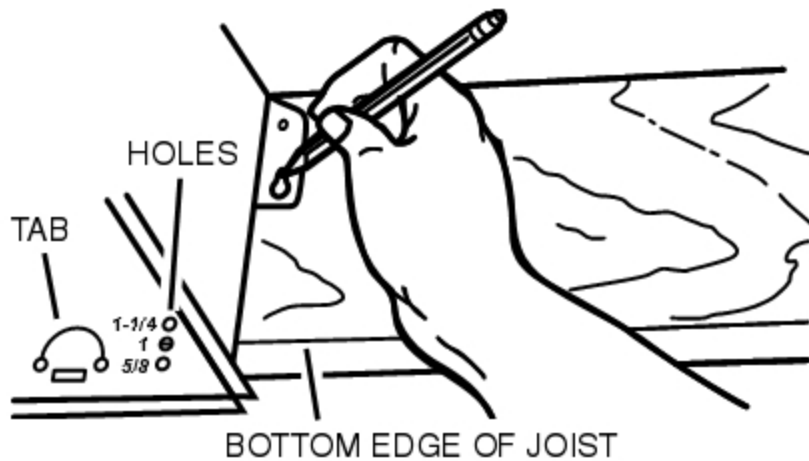

2. Position mounting brackets against joist so that bottom edge of housing will be flush with finished ceiling.

Additional positioning feature for 5/8", 1", & 1-1/4" thick ceiling material:

Holes in corners of housing are labeled with various ceiling material thicknesses. Position housing so bottom edge of joist is visible through a matched set of holes. The housing is now in the proper position for that ceiling material thickness.

Additional positioning feature for 1/2" thick ceiling material:

Bend two tabs, on side of housing, 90° outward. Lift housing until tabs contact underside of joist.

Mark the keyhole slot on both mounting brackets.

INSTALL THE HOUSING (continued)

New Construction

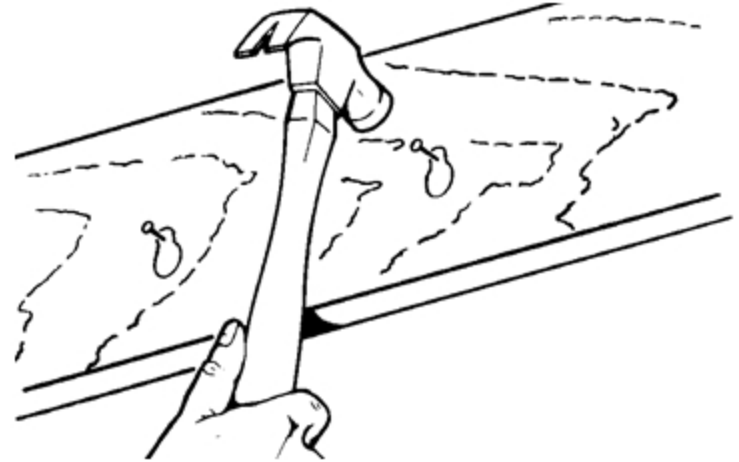

3. Set housing aside and drive nails partially into joist at the top of both keyhole marks.

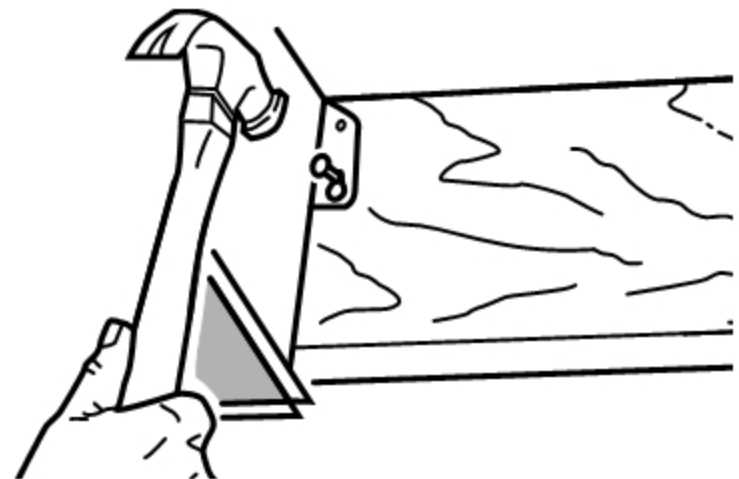

4. Hang housing from nails and pound nails tight. To ensure a noise-free mount, pound another nail through the top hole of each mounting tab.

Existing Construction

1. Choose the location for your fan/light in the ceiling. For best possible performance, use the shortest possible duct run and a minimum number of elbows.

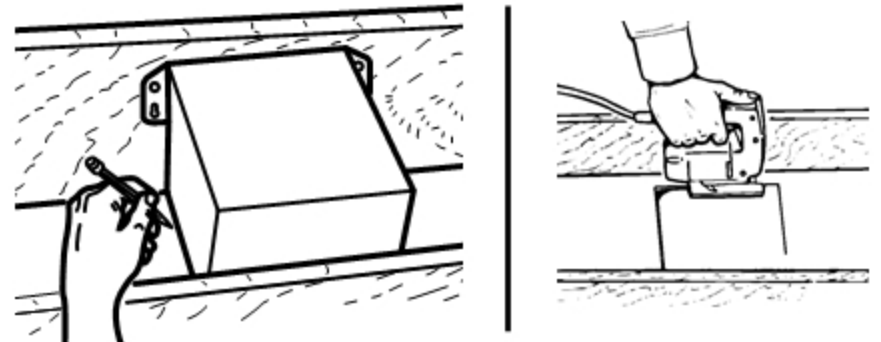

2. In attic, position mounting brackets against joist. Trace outline of housing on ceiling material.
3. Set housing aside and cut ceiling opening slightly larger than marked.

INSTALL THE HOUSING (continued)

Existing Construction

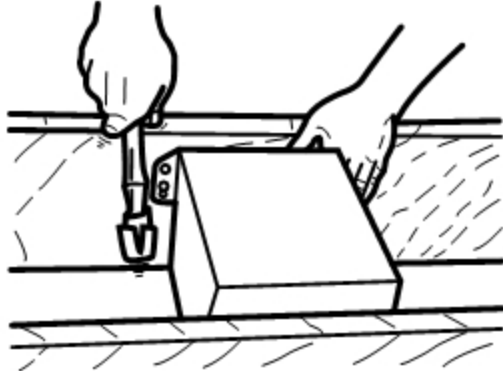

- Place housing in opening so that its bottom edge is flush with finished ceiling. Nail to joist through keyhole on both sides. To ensure a noise-free installation, drive another nail through the top hole of each mounting bracket.

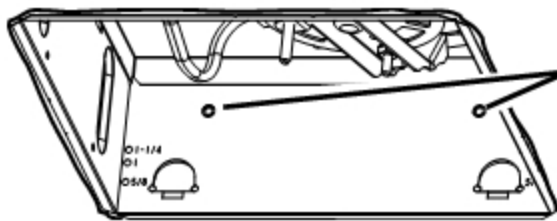

ADDITIONAL MOUNTING HOLES

- Additional mounting holes are provided for installations where access from above is inconvenient or not possible. Nail or screw housing directly to joists or framing.

INSTALL THE DUCTWORK

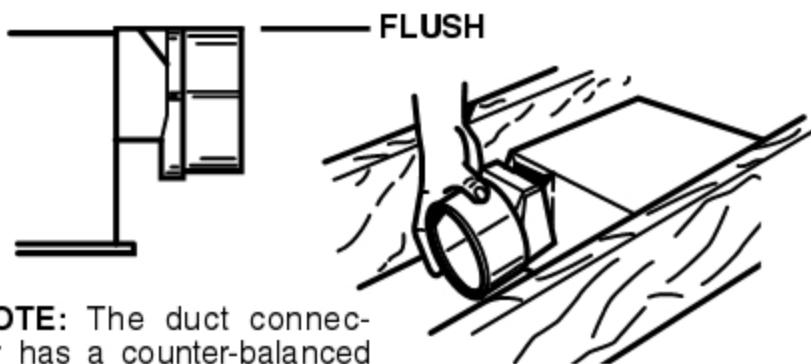

NOTE: The duct connector has a counter-balanced damper flap. The flap will be "open" approx. 1" when duct connector is attached to housing. This design permits insulation to be in direct contact with fan/light housing per UL (Underwriters Laboratories) standards. The slightest backdraft, however, will close the damper flap, preventing air from entering unit or finished space.

- Snap the damper/duct connector onto housing. Make sure that tabs on the connector lock into slots in housing. Top of damper/duct connector should be flush with top of housing.
- Connect 4" round duct to damper/duct connector and extend duct to outside through a roof or wall cap. Check damper to make sure that it opens freely. Tape all duct connections to make them secure and air tight.

CONNECT THE WIRING

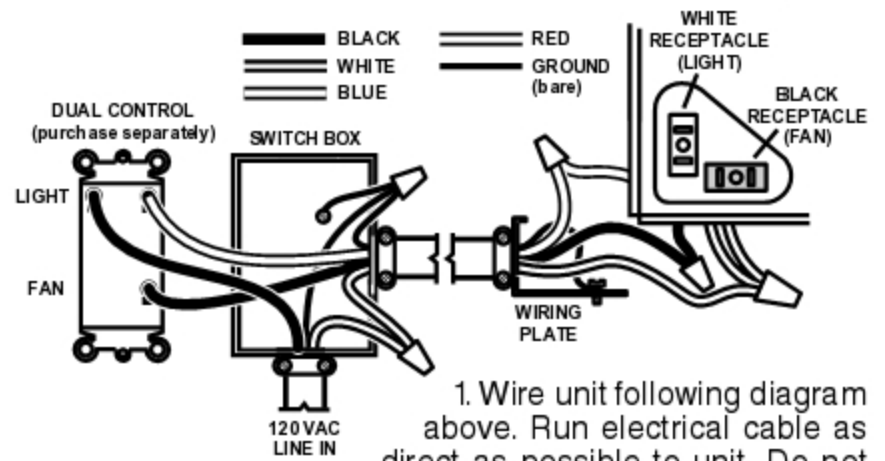
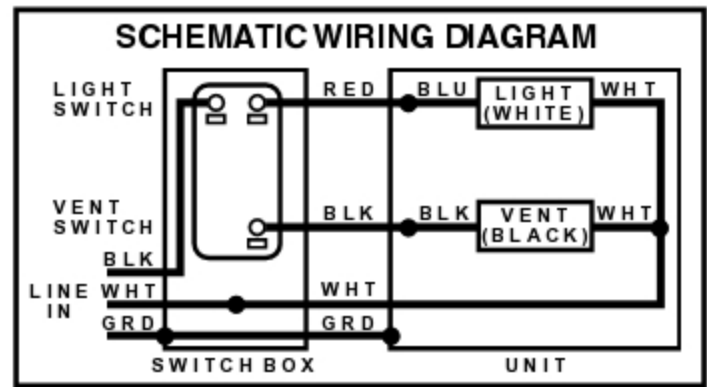

- Wire unit following diagram above. Run electrical cable as direct as possible to unit. Do not allow cable to touch sides or top of unit after installation is complete.

ATTACH THE GRILLE PAN AND GLASS SHADE

- Locate the grille pan over the fan housing and connect the wiring harness plug into white receptacle in the fan housing.
- Insert rod through center hole of grille pan. Use washer between collar on rod and pan.
- Thread rod onto grille screw in housing, until pan is tight against ceiling. Do not over-tighten mounting rod.
- Install bulbs. Use 60-watt (maximum), B10 type, candelabra bulbs.
- Place washer and glass shade over mounting rod and align shade onto grille pan. Secure glass shade to grille pan with finial cap and nut as shown.
- Restore electrical power and check operation of the unit.

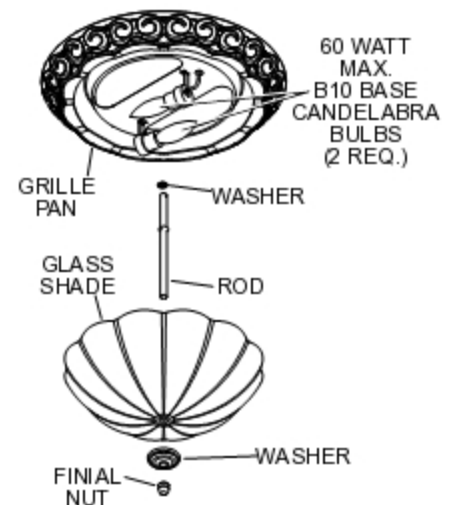
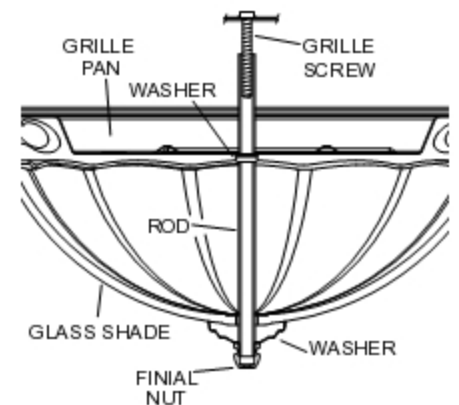

USE AND CARE

WARNING: DISCONNECT ELECTRICAL POWER SUPPLY AND LOCK OUT SERVICE PANEL BEFORE CLEANING OR SERVICING THIS UNIT.

BULB REPLACEMENT

Remove glass shade. Replace bulbs as required. Replace glass shade.
Use 60-watt (maximum), B10 type, candelabra bulbs.

MOTOR LUBRICATION

The motor is permanently lubricated. Do not oil or disassemble motor.

USE AND CARE

CLEANING

TO CLEAN GLASS SHADE AND GRILLE PAN:

Remove glass shade. Shade can be wiped clean with a mild detergent solution or glass cleaner and dried with a soft cloth. Remove 2 bulbs. Grille pan may be gently vacuumed and wiped clean with a soft cloth. Never use abrasive cloth, steel wool pads or scouring powders on glass shade or grille pan. METAL AND ELECTRICAL PARTS SHOULD NEVER BE IMMERSSED IN WATER.

TO CLEAN FAN ASSEMBLY:

Remove grille pan and unplug fan assembly (black receptacle). Gently vacuum fan, motor and interior of housing. METAL AND ELECTRICAL PARTS SHOULD NEVER BE IMMERSSED IN WATER.

SERVICE PARTS

KEY	PART NO.	DESCRIPTION
1	99527180	Glass Shade (764BN, 764WH)
	99527181	Glass Shade (764RB)
2	97018137	Shade Mounting Hardware (764BN)
	97018140	Shade Mounting Hardware (764RB)
	97018141	Shade Mounting Hardware (764WH)
3	99260558	Motor Nut, Hex Lock #8-32 (3 req.)
4	99250959	Motor Washer (3 req.)
5	99100491	Motor Grommet (3 req.)
6	99150583	Grille Screw
7	97016722	Motor
8	99020276	Blower Wheel
9	99270981	Lamp Receptacle, White
10	99270982	Motor Receptacle, Black
11	98009612	Wiring Panel
12	99150471	Ground Screw
13	99170245	Screw, #8-18 X 3/8"
14	98008868	Wiring Plate
15	97014185	Damper / Duct Connector
16	97014922	Housing Assembly
17	97016630	Motor Plate
A	97018133	Light Fixture Assembly (764BN)
	97018132	Light Fixture Assembly (764RB)
	97018136	Light Fixture Assembly (764WH) (Light Fixture Assembly includes Glass Shade (Key No. 1), Mounting Hardware (Key No.2), and Grille Pan Assembly B
B	99391086	Grille Pan Assembly (764BN)
	99391087	Grille Pan Assembly (764RB)
	99391088	Grille Pan Assembly (764WH)
C	97016671	Blower Assembly (Includes Key Nos. 3 thru 8)
D	97015171	Wire Panel Assembly (Includes Key Nos. 9, 10, 11)

Order replacement parts by "PART NO." - not by "KEY NO."

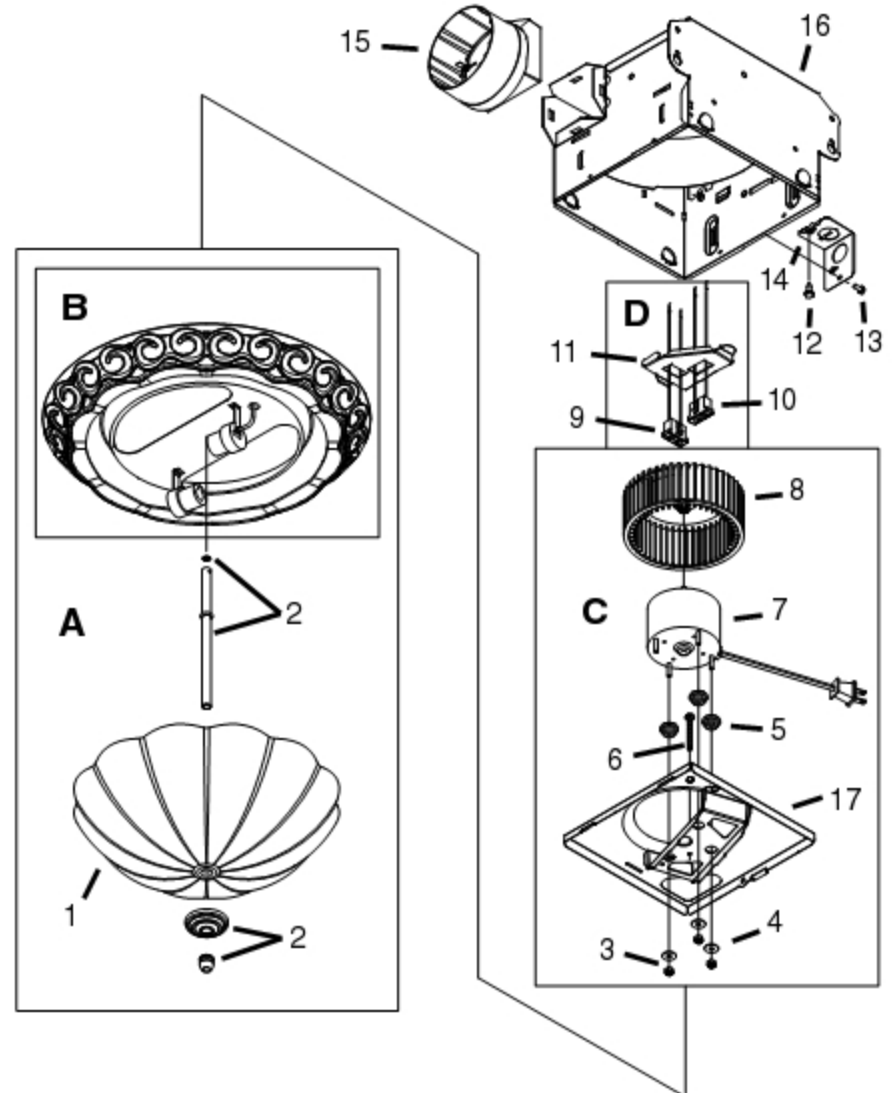

WARRANTY

BROAN-NU TONE ONE YEAR LIMITED WARRANTY

Broan-NuTone warrants to the original consumer purchaser of its products that such products will be free from defects in materials or workmanship for a period of one year from the date of original purchase. THERE ARE NO OTHER WARRANTIES, EXPRESS OR IMPLIED, INCLUDING, BUT NOT LIMITED TO, IMPLIED WARRANTIES OF MERCHANTABILITY OR FITNESS FOR A PARTICULAR PURPOSE.

During this one-year period, Broan-NuTone will, at its option, repair or replace, without charge, any product or part which is found to be defective under normal use and service.

THIS WARRANTY DOES NOT EXTEND TO FLUORESCENT LAMP STARTERS AND TUBES. This warranty does not cover (a) normal maintenance and service or (b) any products or parts which have been subject to misuse, negligence, accident, improper maintenance or repair (other than by Broan-NuTone), faulty installation or installation contrary to recommended installation instructions. The duration of any implied warranty is limited to the one-year period as specified for the express warranty. Some states do not allow limitation on how long an implied warranty lasts, so the above limitation may not apply to you.

BROAN-NU TONE'S OBLIGATION TO REPAIR OR REPLACE, AT BROAN-NU TONE'S OPTION, SHALL BE THE PURCHASER'S SOLE AND EXCLUSIVE REMEDY UNDER THIS WARRANTY. BROAN-NU TONE SHALL NOT BE LIABLE FOR INCIDENTAL, CONSEQUENTIAL OR SPECIAL DAMAGES ARISING OUT OF OR IN CONNECTION WITH PRODUCT USE OR PERFORMANCE. Some states do not allow the exclusion or limitation of incidental or consequential damages, so the above limitation or exclusion may not apply to you.

This warranty gives you specific legal rights, and you may also have other rights, which vary from state to state. This warranty supersedes all prior warranties.

To qualify for warranty service, you must (a) notify Broan-NuTone at the address or telephone number below, (b) give the model number and part identification and (c) describe the nature of any defect in the product or part. At the time of requesting warranty service, you must present evidence of the original purchase date.

Broan-NuTone LLC Hartford, Wisconsin www.broan.com 800-558-1711