

This Owner's Manual is provided and hosted by [Appliance Factory Parts](#).



# BROAN HRV90HT Owner's Manual

[Shop genuine replacement parts for BROAN HRV90HT](#)



[Find Your BROAN Air Cleaner Parts - Select From 37 Models](#)

----- Manual continues below part list -----

## Available Replacement Parts for BROAN HRV90HT

[SV16031](#)

OBE103609 SRV ERV FOAM FILTER

# **BROAN**<sup>®</sup>

FRESH AIR SYSTEMS

## INSTALLATION INSTRUCTIONS HRV90H AND ERV90HC

Model no.: HRV90HT  
(HRV with ports on top)



VB0082

Model no.: HRV90HS  
(HRV with ports on sides)



VB0081

Model no.: ERV90HCT  
(ERV with ports on top)



VB0080

Model no.: ERV90HCS  
(ERV with ports on sides)



VB0079

RESIDENTIAL USE ONLY

**READ AND SAVE THESE INSTRUCTIONS**



06010C rev. H

## ABOUT THIS MANUAL

---

Because of the large amount of models covered by this publication, the illustrations are typical ones. Some details of your unit may be slightly different than the ones shown.

Please take note that this manual uses the following symbols to emphasize particular information:

### **WARNING**

**Identifies an instruction which, if not followed, might cause serious personal injuries including possibility of death.**

### **CAUTION**

**Denotes an instruction which, if not followed, may severely damage the unit and/or its components.**

NOTE: Indicates supplementary information needed to fully complete an instruction.

We welcome any suggestions you may have concerning this manual and/or the unit, and we would appreciate hearing your comments on ways to better serve you. Please contact us by phone at 1-800-558-1711.

## ABOUT THESE UNITS

---

### LIMITATION

---

For residential (domestic) installation only. This unit must be installed in accordance with all national and local regulations, building codes and safety codes.

### **WARNING**

---

**TO REDUCE THE RISK OF FIRE, ELECTRIC SHOCK, OR INJURY TO PERSON(S) OBSERVE THE FOLLOWING:**

1. Use this unit only in the manner intended by the manufacturer. If you have questions, contact the manufacturer at the address or telephone number listed in the warranty.
2. Before servicing or cleaning the unit, disconnect power cord from electrical outlet.
3. This unit is not designed to provide combustion and/or dilution air for fuel-burning appliances.
4. When cutting or drilling into wall or ceiling, do not damage electrical wiring and other hidden utilities.
5. Do not use this unit with any solid-state speed control device other than main optional wall control VT4W, and no other optional auxiliary wall controls than 60-minute crank timer and/or 20-minute lighted push button and/or Humidity Control.
6. This unit must be grounded. The power supply cord has a 3-prong grounding plug for your personal safety. It must be plugged into a mating 3-prong grounding receptacle, grounded in accordance with the national electrical code and local codes and ordinances. Do not remove the ground prong. Do not use an extension cord.
7. Do not install this unit in a cooking area or connect directly to any appliances.
8. Do not use to exhaust hazardous or explosive materials and vapors.
9. When performing installation, servicing or cleaning these units, it is recommended to wear safety glasses and gloves.
10. Due to the weight of the unit, two installers are recommended to perform installation.
11. When the federal, provincial or state legislation comprises more restrictive installation and/or certification requirements, the aforementioned requirements prevail on those of this document and the installer agrees to conform to these at his own expenses.

### CAUTION

---

1. To avoid premature clogged filters, turn OFF the unit during construction or renovation.
2. Please read specification label on product for further information and requirements.
3. Be sure to duct air outside – Do not intake / exhaust air into spaces within walls or ceiling or into attics, crawl spaces, or garage.
4. Intended for residential installation only in accordance with the requirements of NFPA 90B.
5. Do not run any air ducts directly above or closer than 2 ft (0.61 m) to any furnace or its supply plenum, boiler, or other heat producing appliance. If a duct has to be connected to the furnace return plenum, it must be connected not closer than 9'10" (3 m) from this plenum connection to the furnace.
6. The ductwork is intended to be installed in compliance with all local and national codes that are applicable.
7. When leaving the house for a long period of time (more than two weeks), a responsible person should regularly check if the unit operates adequately.
8. If the ductwork passes through an unconditioned space (e.g.: attic), the unit must operate continuously except when performing maintenance and/or repair. Also, the ambient temperature of the house should never drop below 18°C (65°F).

---

# TABLE OF CONTENTS

---

1.	TECHNICAL DATA	4-6
1.1	AIR DISTRIBUTION (NORMAL OPERATION)	4
1.2	AIR DISTRIBUTION (RECIRCULATION OR DEFROST MODE)	4
1.3	SPECIFICATIONS	4
1.4	PERFORMANCE CHARTS	5
1.5	DIMENSIONS	6
1.6	CONTROLS AND LINKAGE POSSIBILITY	6
2.	TYPICAL INSTALLATIONS	7-8
2.1	FULLY DUCTED SYSTEM	7
2.2	CENTRAL DRAW POINT	7
2.3	SIMPLIFIED INSTALLATION	7
2.4	INSTALLATION FOR ERV UNITS ONLY	8
3.	INSTALLATION	9-16
3.1	INSPECT THE CONTENT OF THE BOX	9
3.2	LOCATING THE UNIT	9
3.3	UNIT PREPARATION	9
3.4	HOW TO HANG THE UNIT	10
3.5	PLANNING OF THE DUCTWORK	10
3.6	INSTALLING THE DUCTWORK AND REGISTERS	10-12
3.7	CONNECTING THE DUCT TO THE UNIT	13
3.8	INSTALLING THE TANDEM® TRANSITION KIT	13-15
3.9	INSTALLING 2 EXTERIOR HOODS	16
4.	CONTROLS	17-19
4.1	INTEGRATED CONTROL	17
4.2	ELECTRICAL CONNECTION TO OPTIONAL WALL CONTROLS	17-18
4.3	VT4W OPTIONAL MAIN WALL CONTROL OPERATION	18
4.4	OPTIONAL AUXILIARY WALL CONTROLS OPERATION	19
5.	ELECTRICAL CONNECTION TO THE FURNACE	19
6.	WIRING DIAGRAM	20
7.	BALANCING THE UNIT	22
8.	CONNECTING THE DRAIN	21
9.	MAINTENANCE	23-24
9.1	BIANNUAL MAINTENANCE	23-24
9.2	ANNUAL MAINTENANCE	24
10.	SERVICE PARTS	25
11.	TROUBLESHOOTING	26

# 1. TECHNICAL DATA

## 1.1 AIR DISTRIBUTION (NORMAL OPERATION)

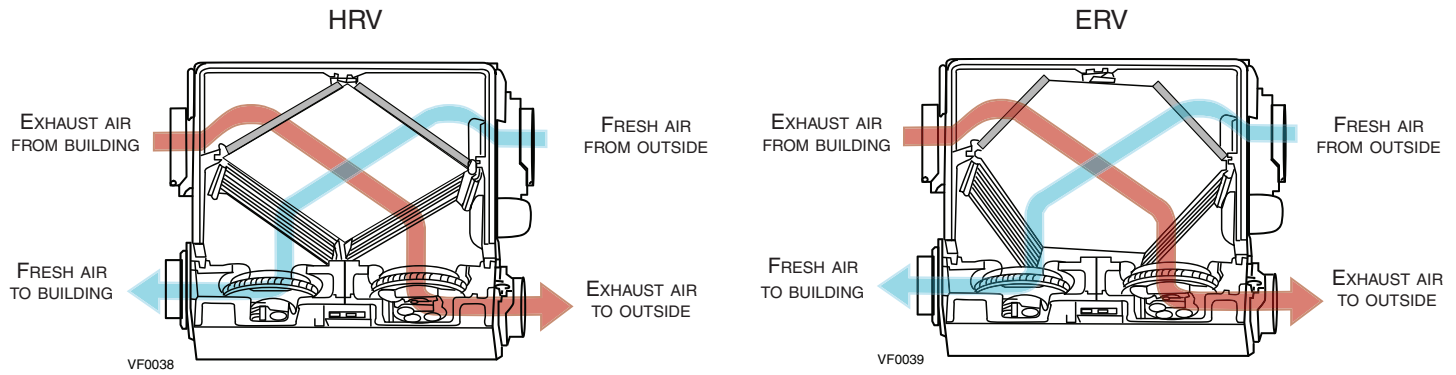

## 1.2 AIR DISTRIBUTION (RECIRCULATION OR DEFROST MODE)

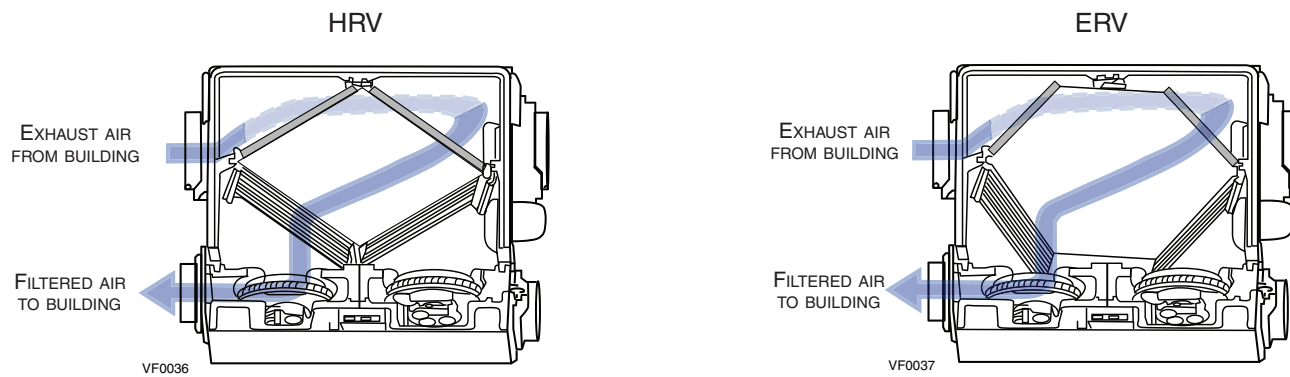

Outside Temperature		HRV and ERV Defrost Cycles	
Celcius (°C)	Fahrenheit (°F)	Defrosting (min.)	Operation time (min.) between each defrost cycle
-5 to -27	23 to -17	9	23
-27 and less	-17 and less	10	22

## 1.3 SPECIFICATIONS

MODEL	HRV	ERV
WEIGHT	42 lb (19 kg)	45 LB (20.4 KG)
OVAL PORTS	FIT 5" (127 MM) DUCTS	FIT 5" (127 MM) DUCTS
DRAIN DIAMETER	1/2" (12 MM)	N/A
INSTALLATION	CHAINS, SPRINGS AND HOOKS (PROVIDED WITH THE UNIT)	
MOTOR SPEEDS	HIGH AND LOW SPEED	
ELECTRICAL SUPPLY	120 V, 60 Hz	120 V, 60 Hz
POWER CONSUMPTION	150 WATTS	160 WATTS

# 1. TECHNICAL DATA (CONT'D)

## 1.4 PERFORMANCE CHARTS

### 1.4.1 HRV UNITS

#### VENTILATION PERFORMANCE

EXT. STATIC PRESSURE		NET SUPPLY AIR FLOW			GROSS AIR FLOW					
PA	IN. W. G.	AIR FLOW			SUPPLY			EXHAUST		
		L/S	CFM	M <sup>3</sup> /H	L/S	CFM	M <sup>3</sup> /H	L/S	CFM	M <sup>3</sup> /H
25	.1	52	110	187	52	110	187	58	122	205
50	.2	50	106	180	50	106	180	55	116	198
75	.3	48	101	173	48	102	173	53	113	191
100	.4	45	96	162	46	97	166	50	107	180
125	.5	43	92	155	43	92	155	49	103	173
150	.6	41	87	148	41	87	148	45	96	162
175	.7	38	81	138	38	81	137	43	91	155
200	.8	35	75	126	36	76	130	40	85	144

#### ENERGY PERFORMANCE

SUPPLY TEMPERATURE		NET AIR FLOW			POWER CONSUMED WATTS	SENSIBLE RECOVERY EFFICIENCY	APPARENT SENSIBLE EFFECTIVENESS	LATENT RECOVERY/MOISTURE TRANSFER
°C	°F	L/S	CFM	M <sup>3</sup> /H				
HEATING								
0	32	23	48	82	68	66	78	0.07
0	32	30	63	108	82	65	76	0.04
0	32	44	93	157	116	59	68	0.04
-25	-13	30	63	108	110	55	81	0.08
						TOTAL RECOVERY EFFICIENCY		
35 95						NOT TESTED		
-	-	-	-	-	-			

NOTE: ALL SPECIFICATIONS ARE SUBJECT TO CHANGE WITHOUT NOTICE.

### 1.4.2 ERV UNITS

#### VENTILATION PERFORMANCE

EXT. STATIC PRESSURE		NET SUPPLY AIR FLOW			GROSS AIR FLOW					
PA	IN. W. G.	AIR FLOW			SUPPLY			EXHAUST		
		L/S	CFM	M <sup>3</sup> /H	L/S	CFM	M <sup>3</sup> /H	L/S	CFM	M <sup>3</sup> /H
25	.1	55	116	197	56	119	202	59	125	212
50	.2	53	113	192	55	116	197	57	121	206
75	.3	50	107	182	52	111	189	54	115	195
100	.4	49	104	177	50	107	182	53	112	190
125	.5	46	98	166	48	101	172	50	105	178
150	.6	44	94	160	46	97	165	47	100	170
175	.7	42	88	150	43	91	155	45	95	161
200	.8	39	82	139	40	84	143	42	90	153

#### ENERGY PERFORMANCE

SUPPLY TEMPERATURE		NET AIR FLOW			POWER CONSUMED WATTS	SENSIBLE RECOVERY EFFICIENCY	APPARENT SENSIBLE EFFECTIVENESS	LATENT RECOVERY/MOISTURE TRANSFER
°C	°F	L/S	CFM	M <sup>3</sup> /H				
HEATING								
0	32	13	28	48	73	69	94	0.68
0	32	45	96	163	137	62	74	0.48
-25	-13	25	54	92	102	54	83	0.58
						TOTAL RECOVERY EFFICIENCY		
35 95						54		
-	-	-	-	-	-			

NOTE: ALL SPECIFICATIONS ARE SUBJECT TO CHANGE WITHOUT NOTICE.

# 1. TECHNICAL DATA (CONT'D)

## 1.5 DIMENSIONS

### 1.5.1 DIMENSIONS FOR PORTS ON SIDES UNITS

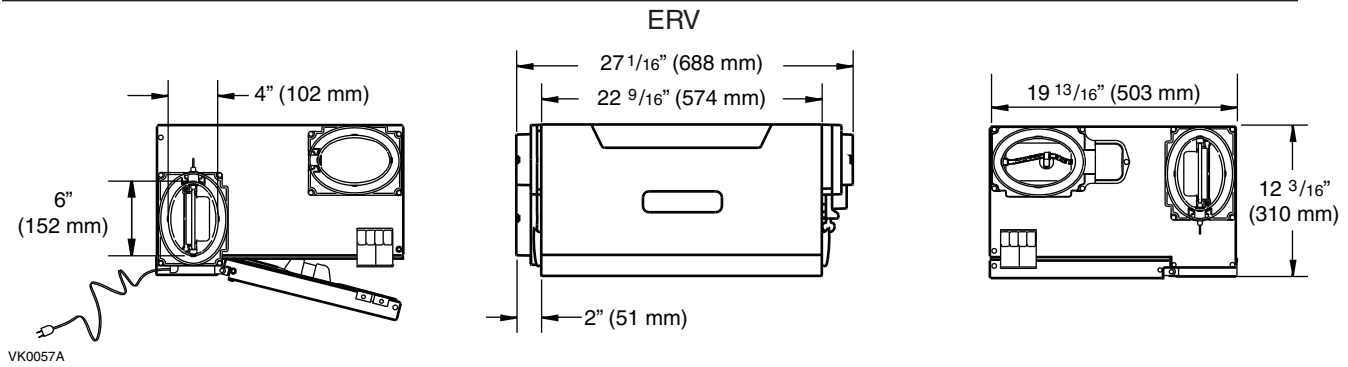
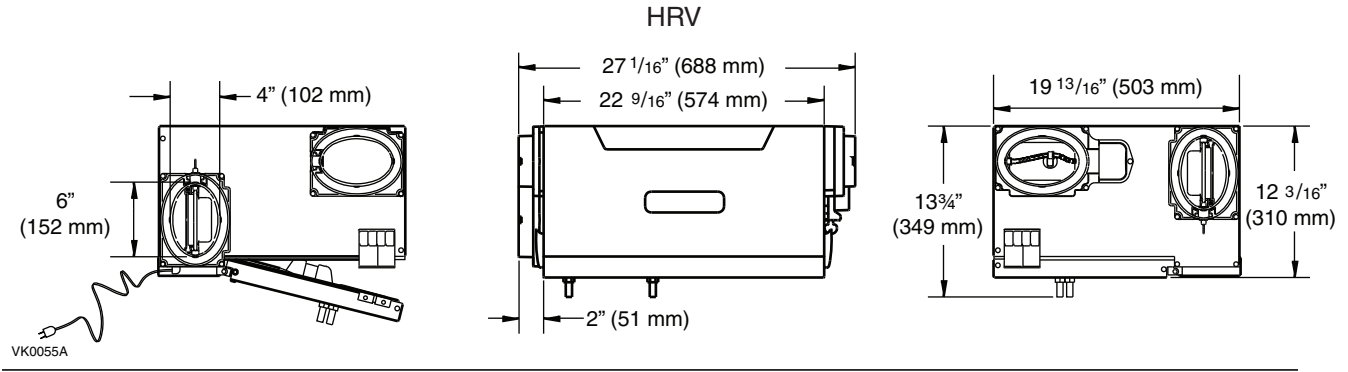

### 1.5.2 DIMENSIONS FOR PORTS ON TOP UNITS

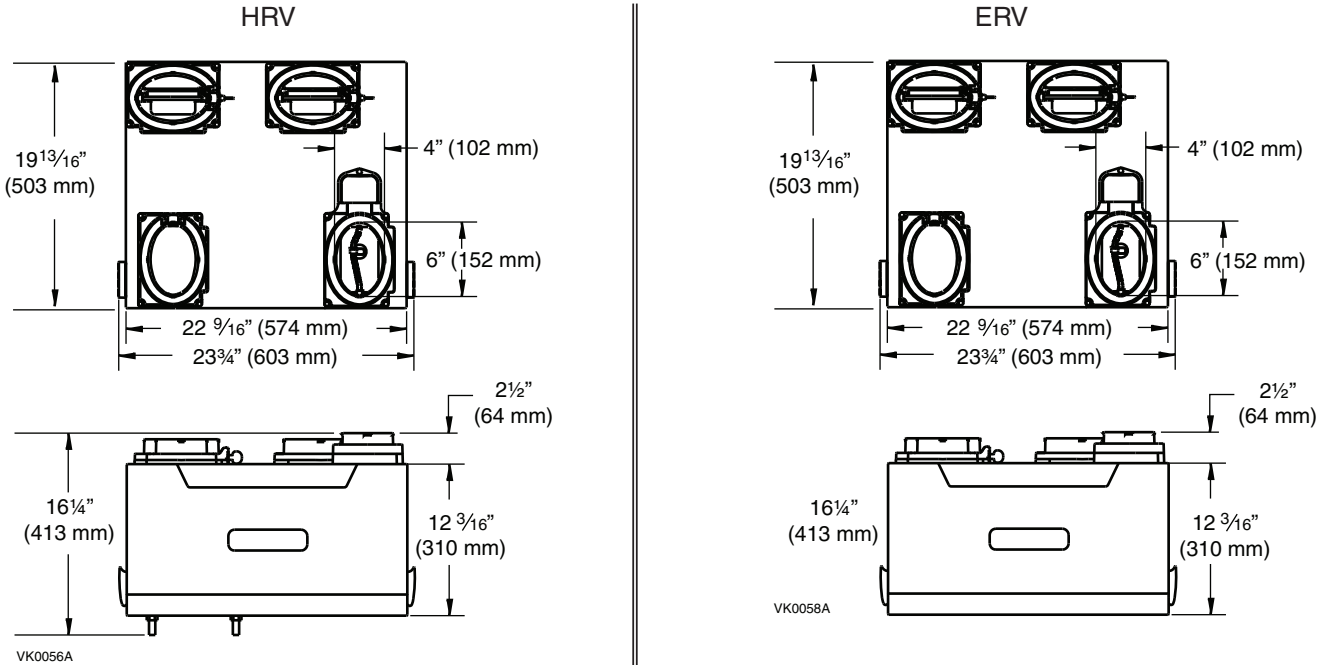

## 1.6 CONTROLS AND LINKAGE POSSIBILITY

### MAIN CONTROL

- VT4W

### AUXILIARY CONTROLS

- 20-MINUTE PUSH BUTTON TIMER
- 60-MINUTE CRANK TIMER
- HUMIDITY CONTROL

### LINKAGE POSSIBILITY

- AIR HANDLER INTERLOCK  
(USED WITH FORCED AIR SYSTEM)

## 2. TYPICAL INSTALLATIONS

Installations may vary according to the type of unit and the ports configuration (top or sides). Use the following illustrations as guidelines to help you decide on how the unit will be installed.

All the units should be hung from the joists.

In every case, bathroom fans and a range hood should be used to exhaust stale air. Also, for homes with more than one level, we recommend one exhaust register at the highest level.

There are 3 installation methods: Fully ducted, Central Draw Point and Simplified Installation.

NOTE: An electrical outlet has to be available within 3 feet of the unit.

### 2.1 FULLY DUCTED SYSTEM (PRIMARILY FOR HOMES WITH RADIANT HOT WATER OR ELECTRIC BASEBOARD HEATING)

Stale air coming from the registers located at the highest level of the house is exhausted to the outside. Fresh air from outside is filtered and supplied by the register located in the lowest liveable level.

Homes with more than one level require at least one exhaust register at the highest level.

See figure at right.

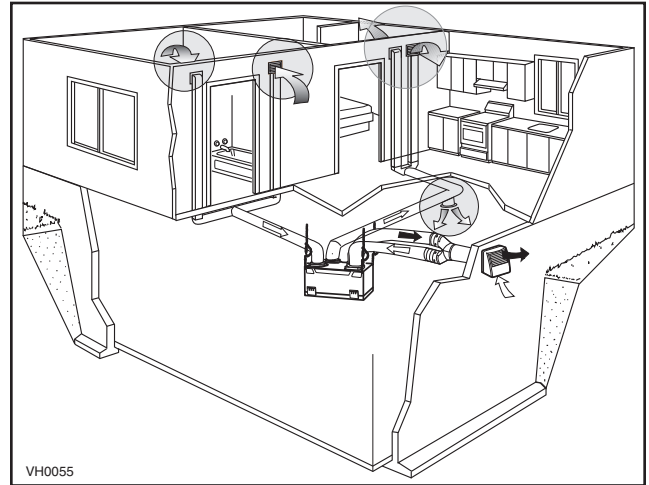

### 2.2 CENTRAL DRAW POINT (CONNECTION TO A FORCED AIR SYSTEM)

Stale air coming from the registers located at the highest level of the house is exhausted to the outside. Fresh air from outside is filtered and supplied to the return (plenum) or the supply duct of the forced air unit. See figure at right.

For this type of installation, it is not essential that the forced air system blower runs when the unit is in operation, but we recommend it.

NOTE: Home with multiple forced air systems should have one unit on each system.

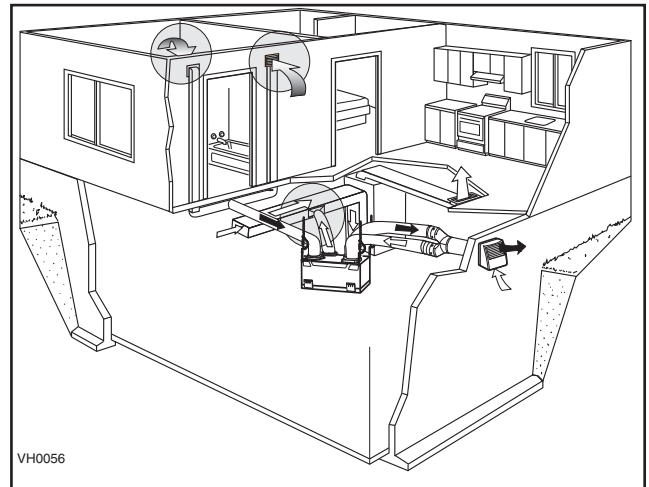

### 2.3 SIMPLIFIED INSTALLATION (CONNECTION TO A FORCED AIR SYSTEM)

Stale air is exhausted to the outside. Fresh air from outside is filtered and supplied to the return (plenum) or the supply duct of the forced air unit. See figure at right.

To avoid cross-contamination and achieve the highest efficiencies, the forced air system blower must always be ON.

NOTE: Home with multiple forced air systems should have one unit on each system.

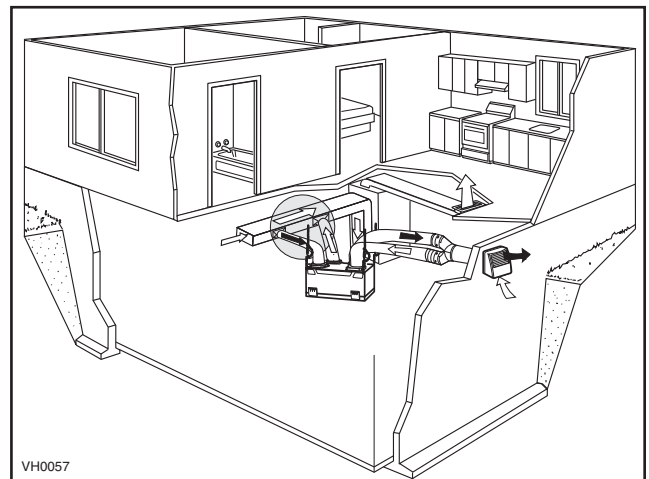

## 2. TYPICAL INSTALLATIONS (CONT'D)

### 2.4 INSTALLATION FOR ERV UNITS ONLY

#### 2.4.1 GEOGRAPHICAL LOCATION

The ERV units are created to meet specific requirements related to geographical locations. Take a look at the map below; the shaded area shows the limits where the ERV unit can be installed. However, there is no geographical limitation for installing an HRV unit.



**NOTE:** The ERV unit is designed to assist in the management of humidity introduced into the home. During cooling season, in extreme humidity conditions, the use of additional dehumidification unit may be required to quickly remove all excess moisture. During heating season, in extreme dryness conditions, the use of a humidifier may be required if the indoor air is still too dry.

#### 2.4.2 ERV UNITS ATTIC INSTALLATION

All 3 types of installations can be used in the attic (Fully ducted system, Central Draw Point or Simplified). The example shown below is a Simplified installation (connection to a forced air system).

#### **CAUTION**

**Due to the potential temperature difference between the attic and the rest of the house, all unit ducts must be insulated.**

#### **CAUTION**

**The attic temperature must always be above 0°C (32°F).**

Stale air is exhausted to the outside. Fresh air from outside is filtered and supplied to the return (plenum) of the forced air unit. See figure at right.

To avoid cross-contamination and achieve the highest efficiencies, the forced air system blower must always be ON.

**NOTE:** Home with multiple forced air systems should have 1 unit on each system.

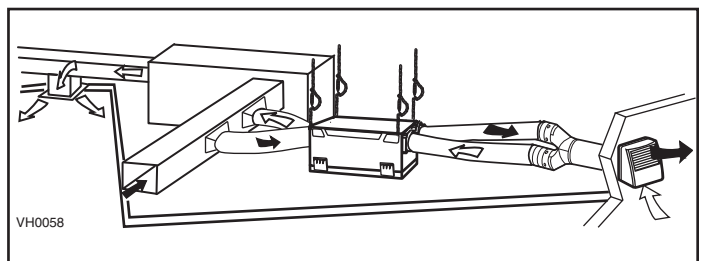

### 3. INSTALLATION

#### 3.1 INSPECT THE CONTENTS OF THE BOX

- Inspect the exterior of the unit for shipping damage. Ensure that there is no damage to the door, door latches, power cord, etc.
- Remove and discard the 2 transport brackets (**A**) and open the door. Discard the styrofoam fillers (ERV units only) and remove the hardware kit from the unit. Inspect the interior of the unit for damage. Ensure that heat or energy recovery core, core filters, insulation, dampers, etc. are all intact.

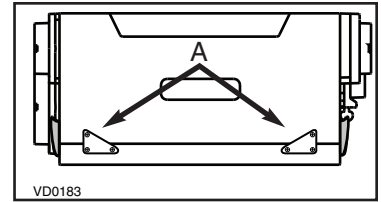

#### 3.2 LOCATING THE UNIT

CHOOSE AN APPROPRIATE LOCATION FOR THE UNIT.

- Within an area of the house where the ambient temperature is between 10°C (50°F) and 65°C (149°F) (basement, furnace room, closet, etc.).
- So as to provide easy access to the interior of the unit, for maintenance.
- Close to an exterior wall, so as to limit the length of the insulated flexible duct to and from the unit.
- Away from hot chimneys and other fire hazards.
- Allow for a power source (standard 3-prong grounding outlet).
- For HRV units ONLY: Close to a drain. If no drain is close by, use a pail to collect run-off.

#### 3.3 UNIT PREPARATION

Both HRV and ERV units are equipped with 2 ports having integrated balancing damper. Turn the thumb screw (**A**) **clockwise** to manually open and adjust the damper (**B**).

**HRV units:** Set the Fresh air to building port to wide open position, and adjust the Exhaust air to outside port to 3rd notch.

**NOTE:** If the unit needs to be balanced, adjust the damper of the Exhaust air to outside port to wide open position. See Section 7.

**ERV units:** Set both Fresh air to building port and Exhaust air to outside port to wide open position.

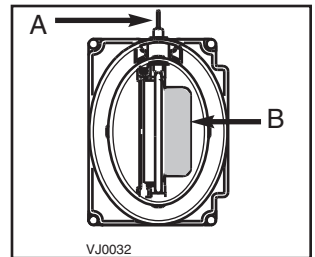

PORT WITH INTEGRATED  
BALANCING DAMPER - TOP VIEW

The door latches location can be changed from sides to front of the unit, according to the installation needs.

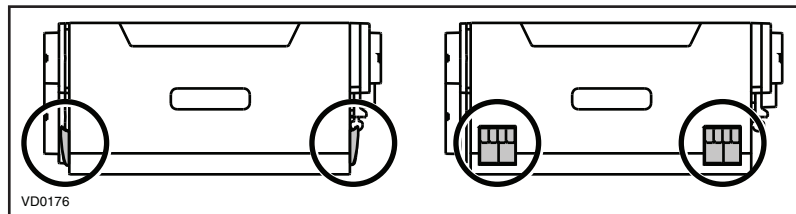

LATCHES ON SIDES OF THE UNIT

LATCHES IN FRONT OF THE UNIT

To do so, turn the unit upside down. Open the latches and unscrew them from the unit. Install the latches on their new locations.

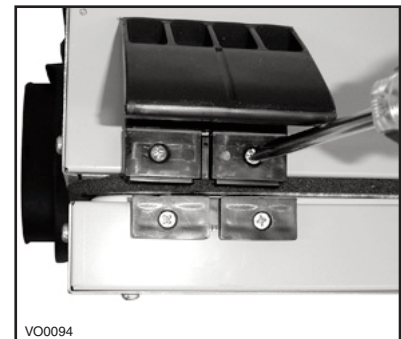
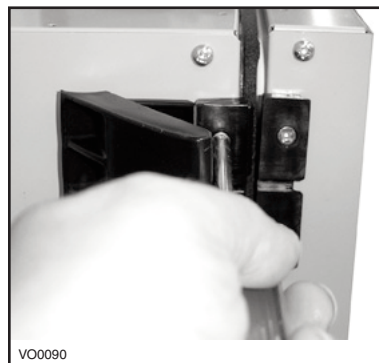
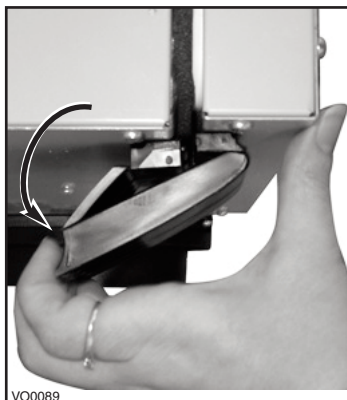

### 3. INSTALLATION (CONT'D)

#### 3.4 HOW TO HANG THE UNIT

Hang the unit with the 4 chains, hooks and springs provided.

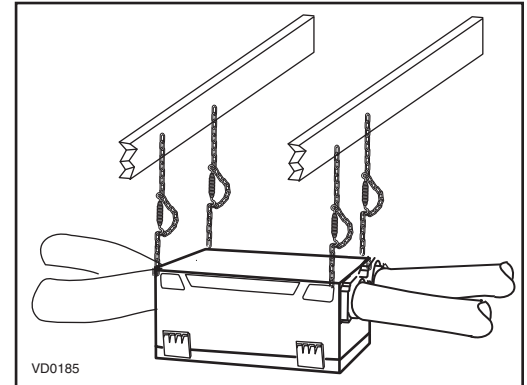

#### CAUTION

**Make sure the unit is level.**

#### 3.5 PLANNING OF THE DUCTWORK

- Keep it simple. Plan for a minimum of bends and joints.
- Keep the length of insulated ducts to a minimum.
- Do not ventilate crawl spaces or cold rooms. Do not attempt to recover the exhaust air from a dryer or a range hood. This would cause clogging of the filters and recovery module.
- If the house has two floors or more, be sure to plan for at least one exhaust register on the highest lived-in level.

#### 3.6 INSTALLING THE DUCTWORK AND REGISTERS

#### ⚠ WARNING

**Never install a stale air exhaust register in a closed room where a combustion device operates, such as a gas furnace, a gas water heater or a fireplace.**

##### 3.6.1 FULLY DUCTED SYSTEM (AS ILLUSTRATED IN SECTION 2.1)

###### **Stale air exhaust ductwork**

- Install the stale air exhaust registers where the contaminants are produced: kitchen, living room, etc. Position the registers as far from the stairway as possible and in such a way that the air circulates in all the lived-in spaces in the house.
- If a register is installed in the kitchen, it must be located at least 4 feet (1.2 m) from the range.
- Install the registers 6 in. to 12 in. (152 mm to 305 mm) from the ceiling on an interior wall OR install them in the ceiling.

###### **Fresh air distribution ductwork**

- Install the fresh air distribution registers in bedrooms, dining rooms, living room and basement.
- Keep in mind that the fresh air registers must be located as far as possible from the stale air registers.
- Install the registers in the ceiling or 6 in. to 12 in. (152 mm to 305 mm) from the ceiling on an interior wall. The duct length should be at least 15' (4.6 m). (The fresh air will then flow through the room and mix with room air, ensuring a continuous renewed airflow.)
- If a register must be floor installed, direct the airflow up the wall.

### 3. INSTALLATION (CONT'D)

#### 3.6 INSTALLING THE DUCTWORK AND REGISTERS (CONT'D)

##### 3.6.2 CENTRAL DRAW POINT SYSTEM (AS ILLUSTRATED IN SECTION 2.2)

###### Stale air exhaust ductwork

Same as for Fully Ducted System, described on point 3.6.1.

###### Fresh air distribution ductwork

#### ⚠ WARNING

When performing duct connections, always use approved tools and materials. Respect all corresponding laws and safety regulations. Please refer to your local building code.

#### CAUTION

When performing duct connections to the furnace supply duct, this duct must be sized to support the additional airflow produced by the HRV/ERV. Also, use a steel duct. It is recommended that the HRV/ERV is running when the furnace is in operation to prevent backdrafting inside HRV/ERV.

There are 2 methods for connecting the unit to the furnace/air handler:

##### Method 1: Supply side connection

- Cut an opening into the furnace supply duct at least 18 inches (0.5 m) from the furnace/air handler.
- Connect this opening to the Fresh air to building port of the HRV/ERV (use steel duct, see figure beside).
- Make sure the HRV/ERV duct form an elbow inside the furnace/air handler ductwork.
- If desired, interlock (synchronize) the furnace/air handler blower operation (see Section 5).

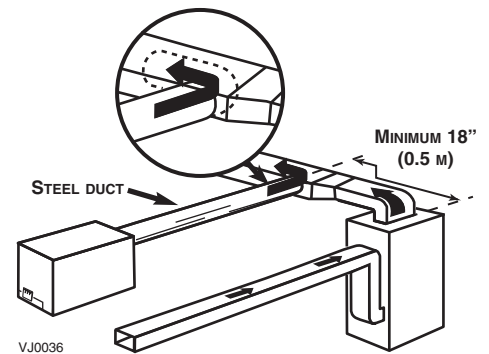

##### Method 2: Return side connection

- Cut an opening into the furnace return duct not less than 10 feet (3.1 m) from the furnace/air handler (A+B).
- Connect this opening to the Fresh air to building port of the HRV/ERV (see figure beside).

NOTE: For Method 2, it is not essential that the furnace/air handler runs when the unit is operation, but we recommend it. If desired, interlock (synchronize) the furnace/air handler blower operation (see Section 5).

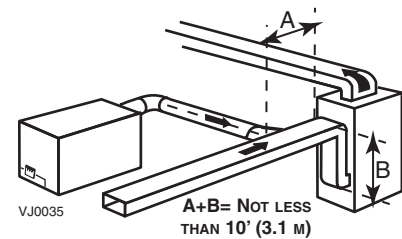

### 3. INSTALLATION (CONT'D)

#### 3.6 INSTALLING THE DUCTWORK AND REGISTERS (CONT'D)

##### 3.6.3 SIMPLIFIED INSTALLATION (AS ILLUSTRATED IN SECTION 2.3)

#### ⚠ WARNING

When performing duct connections, always use approved tools and materials. Respect all corresponding laws and/or safety regulations. Please refer to your local building code.

#### CAUTION

When performing duct connections to the furnace supply duct, this duct must be sized to support the additional airflow produced by the HRV/ERV. Also, use a steel duct. For a Return-Return installation, the furnace blower must be in operation when the HRV/ERV is in operation.

There are 2 methods for connecting the unit to the furnace/air handler:

##### Method 1: Supply-return connection

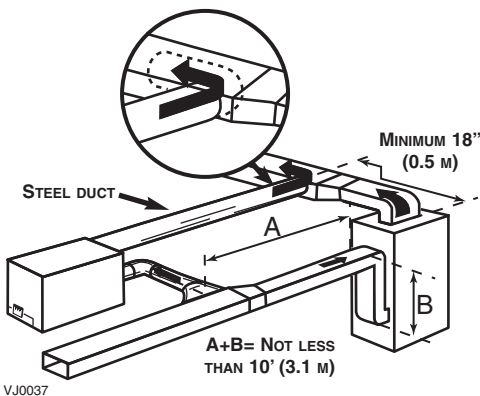

##### Method 2: Return-return without

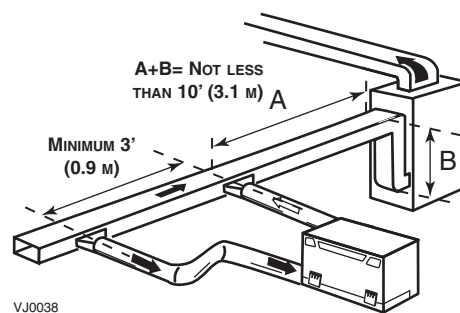

##### Stale air intake

- Cut an opening into the furnace/air handler return duct not less than 10 feet (3.1 m) from the furnace/air handler (A+B).
- Connect this opening to the Exhaust air from building port of the HRV/ERV.

##### Fresh air distribution

- Same instructions as for Method 1 or Method 2, Section 2.6.2.

For Method 2 (Return-return), make sure there is a distance of at least 3 feet (0.9 m) between the 2 connections to the furnace/air handler.

NOTE: For Method 1, it is not essential to synchronize the furnace blower operation with the unit operation, but we recommend it.

#### CAUTION

If using Method 2, make sure the furnace/air handler blower operation is synchronized with the unit operation! See Section 5.

### 3. INSTALLATION (CONT'D)

#### 3.7 CONNECTING THE DUCTS TO THE UNIT

##### Insulated flexible ducts

Use the following procedure for connecting the insulated flexible ducts to the port of the unit (*Exhaust air to outside* and *Fresh air from outside* ports).

#### CAUTION

**Make sure the balancing dampers are set to their appropriate position before connecting the ducts to the ports. See Section 3.3.**

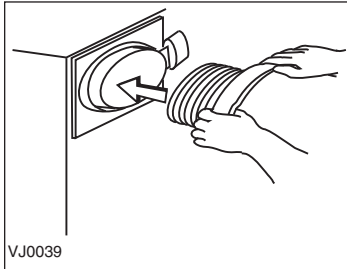

Pull back the insulation to expose the flexible duct.

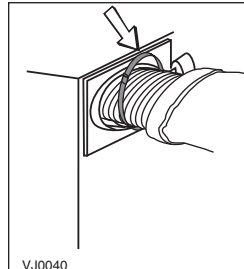

Attach the flexible duct to the port using tie wrap.

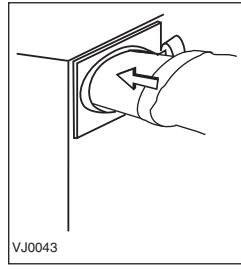

Pull the insulation over the joint and tuck in between the inner and outer rings of the double collar.

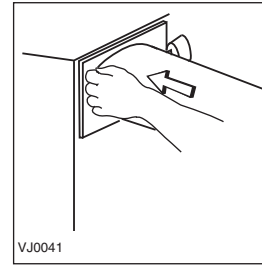

Pull the vapor barrier over the insulation and over the outer ring of the double collar.

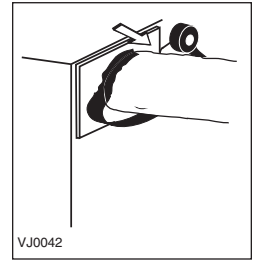

Apply duct tape to the joint making an airtight seal. Avoid compressing the insulation when pulling the tape tightly around the joint. Compressed insulation loses its R value and causes water dripping due to condensation on the exterior surface of the duct.

#### CAUTION

**Make sure the vapor barrier on the insulated ducts does not tear during installation to avoid condensation within the ducts.**

##### Rigid ducts

#### CAUTION

**Do not use screws to connect the rigid ducts to the ports.**

Use a small length of flexible duct to connect the rigid duct to the ports in order to avoid vibration transmissions. Use tie-wraps to perform connections.

#### 3.8 INSTALLING THE TANDEM® TRANSITION\* KIT

Use the following procedure for connecting the insulated flexible ducts to the Tandem Transition (*Exhaust air to outside* and *Fresh air from outside*).

NOTE: The joist opening needed to install the Tandem transition must be 9¾" (248 mm) minimum. Also, the maximum height of the Tandem transition is 8¾" (222 mm). See Tandem Transition end view beside. If the joists are perpendicular to the ducts, or if the connection to the exterior hood is in a limited area, your installation will need two exterior hoods instead of one. In this case, do not use the Tandem Transition kit. See next Section 3.9 INSTALLING 2 EXTERIOR HOODS.

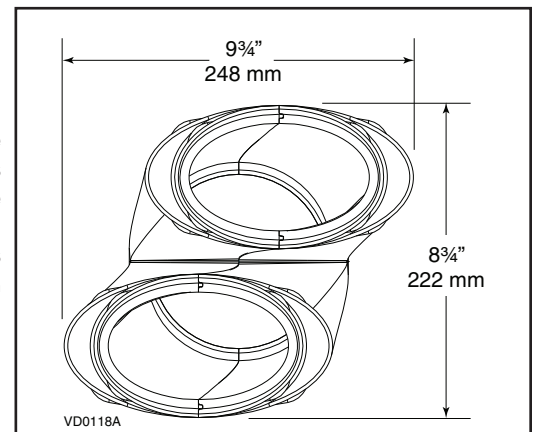

\*Patented.

### 3. INSTALLATION (CONT'D)

#### 3.8 INSTALLING THE TANDEM TRANSITION KIT (CONT'D)

##### 3.8.1 CONNECTION TO TANDEM TRANSITION

1. For each duct, pull back the insulation to expose the interior flexible duct.
2. Connect the interior flexible duct to the smaller part of the Tandem Transition (5" oval) using a tie wrap.
3. Pull the insulation over the joint. Pull the vapor barrier over the insulation.
4. Apply duct tape gently to the joint in order to make an airtight seal. See figures below.

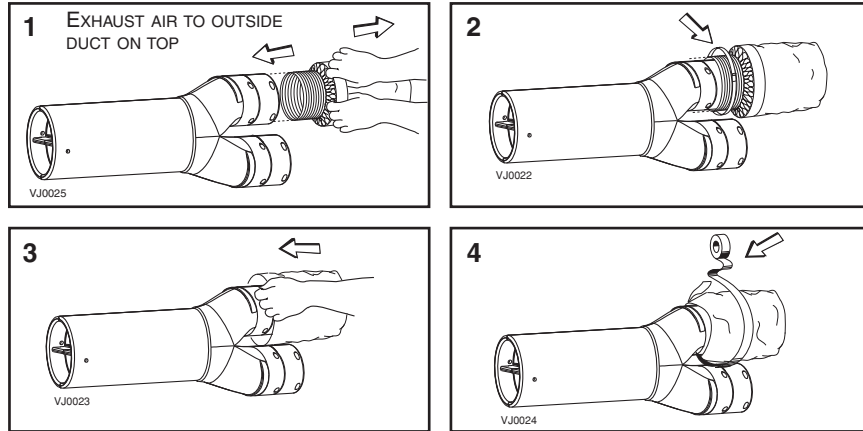

##### 3.8.2 ASSEMBLING DUAL EXTERIOR HOOD\*

Exterior dual hood is coming in separate parts. Using 2 no. 8 x 3/4" screws, assemble the top metal screen and the plastic grille to the dual exterior hood. Then, slide the bottom metal screen to the dual exterior hood. See illustration beside.

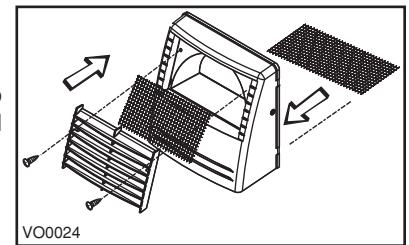

\*PATENTED.

##### 3.8.3 LOCATING THE DUAL EXTERIOR HOOD

The dual exterior hood must be installed at a minimum distance of 18 inches (457 mm) from the ground. See illustration beside.

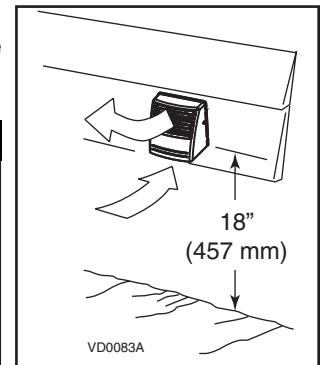

#### **⚠ WARNING**

**Make sure this hood is at least 6 feet (1.8 m) away (or more, as per applicable building codes or standards) from sources of contamination such as:**

- High efficiency furnace vent
- Any exhaust from a combustion source
- Gas meter exhaust, gas barbecue-grill
- Garbage bin

##### 3.8.4 CONNECTING TANDEM TRANSITION TO THE DUAL EXTERIOR HOOD

1. Using a jig saw, cut a 6" diameter hole in the exterior wall and insert the Tandem transition through this hole.

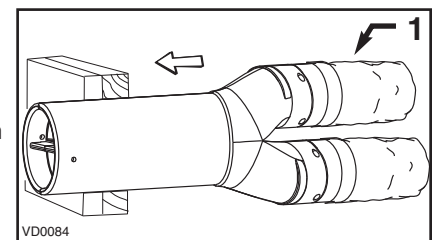

1) EXHAUST AIR TO OUTSIDE DUCT

#### **CAUTION**

**The Tandem Transition must be inserted in such a way that the *Exhaust air to outside* duct will be located on the top.**

### 3. INSTALLATION (CONT'D)

#### 3.8 INSTALLING THE TANDEM TRANSITION KIT (CONT'D)

##### 3.8.4 CONNECTING TANDEM TRANSITION TO THE DUAL EXTERIOR HOOD (CONT'D)

2. Join the end of the Tandem Transition to the rear of the exterior backplate. Secure with 2 Xmas tree pins and seal properly with duct tape.

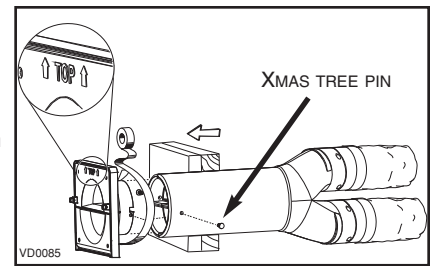

#### CAUTION

The exterior backplate must be installed with the word "TOP" pointing upward.

3. Using 4 no. 8 x 1½" screws, mount the the exterior backplate to the exterior wall. Seal the outline with caulking.

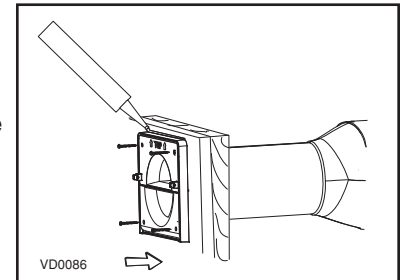

4. Snap the assembled exterior hood on its backplate and secure with 2 provided screws (no. 8 x ¾" long).

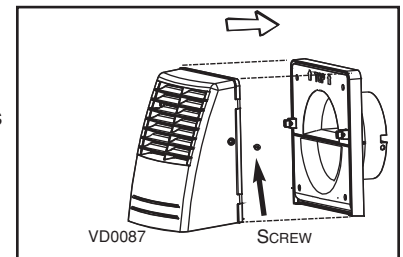

### 3. INSTALLATION (CONT'D)

#### 3.9 INSTALLING 2 EXTERIOR HOODS

Choose an appropriate location to install the exterior hoods:

- There must be a minimum distance of 6 feet (1.8 m) between the hoods to avoid cross-contamination
- There must be a minimum distance of 18 inches (457 mm) from the ground

#### **⚠ WARNING**

**Make sure the intake hood is at least 6 feet (1.8 m) away (or more, as per applicable building codes or standards) from sources of contamination such as:**

- **High efficiency furnace vent**
- **Any exhaust from a combustion source**
- **Gas meter exhaust, gas barbecue-grill**
- **Garbage bin**

Refer to figure below for connecting insulated ducts to the exterior hoods. An "Anti-gust intake hood" should be installed in regions where a lot of snow is expected to fall.

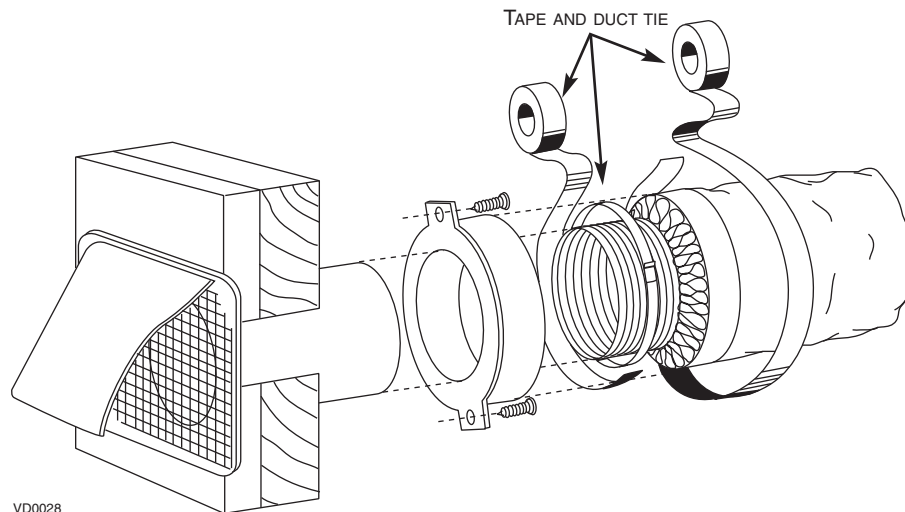
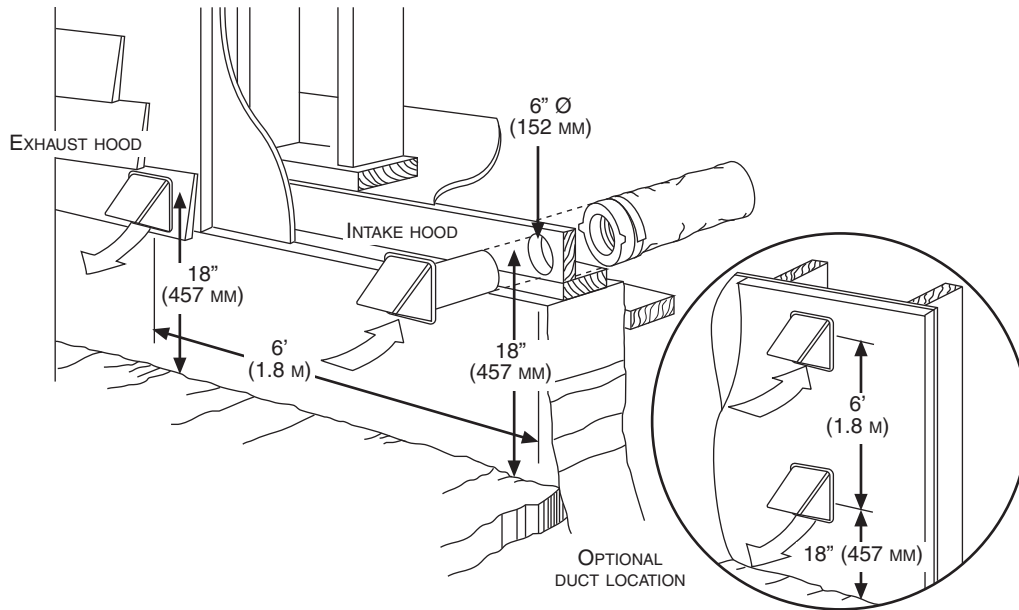

VD0028

## 4. CONTROLS

### 4.1 INTEGRATED CONTROL

All units are equipped with an integrated control, located under the unit, in front of the electrical compartment. Use the push button (1) to control the unit. The LED (2) will then show which mode the unit is in.

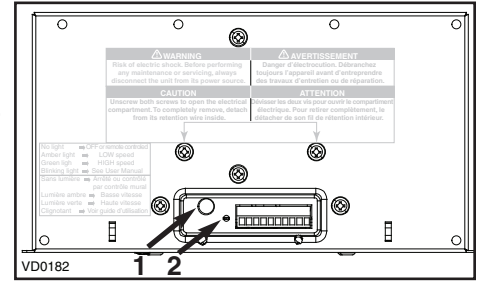

Refer to table below to see how to operate the unit using its integrated control.

PRESS ON PUSH BUTTON	LED COLOR	RESULTS
ONCE	AMBER	UNIT IS ON LOW SPEED
TWICE	GREEN	UNIT IS ON HIGH SPEED
THREE TIMES	NO LIGHT	UNIT IS OFF

If a problem occurs during the unit operation, its integrated control LED (2) will blink. The color of the blinking light depends on the type of error detected. Refer to *Section 11 Troubleshooting* on last page for further details.

#### 4.1.1 BOOT SEQUENCE

The unit boot sequence is similar to a personal computer boot sequence. Each time the unit is plugged in after being unplugged, or after a power failure, the unit will perform a 30-second booting sequence before starting to operate. During the booting sequence, the integrated control LED will light GREEN or AMBER for 5 seconds, and then will shut off for 2 seconds. After that, the LED will light RED for the rest of the booting sequence. During this RED light phase, the unit is checking and resetting the motorized damper position. Once the motorized damper position is completely set, the RED light turns off and the booting sequence is done.

NOTE: No command will be taken until the unit is fully booted.

### 4.2 ELECTRICAL CONNECTION TO OPTIONAL WALL CONTROLS

For more convenience, this unit can also be controlled using an optional main wall control.

NOTES: 1. The integrated control must be turned OFF to use an optional main control.

2. If an optional auxiliary control is used, if activated, this auxiliary control will override the optional main control.

#### ⚠ WARNING

**Always disconnect the unit before making any connections. Failure in disconnecting power could result in electrical shock or damage of the wall control or electronic module inside the unit.**

#### CAUTION

**Never install more than one optional main wall control per unit. Make sure that the wires do not short-circuit between themselves or by touching any other components on the wall control. Avoid poor wiring connections. To reduce electrical interference (noise) potential, do not run wall control wiring next to control contactors or near light dimming circuits, electrical motors, dwelling/building power or lighting wiring, or power distribution panel.**

Use the terminal connector included in the installation kit to perform the electrical connection for main and optional wall controls. Check if all wires are correctly inserted in their corresponding holes in the terminal block. (A wire is correctly inserted when its orange receptacle is lower than another one without wire. On picture beside, wire **A** is correctly inserted, but not wire **B**.)

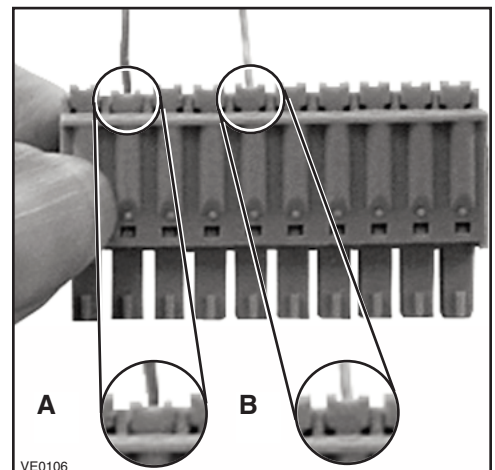

## 4. CONTROLS (CONT'D)

### 4.2 ELECTRICAL CONNECTION TO OPTIONAL WALL CONTROLS (CONT'D)

#### 4.2.1 ELECTRICAL CONNECTION TO VT4W MAIN WALL CONTROL

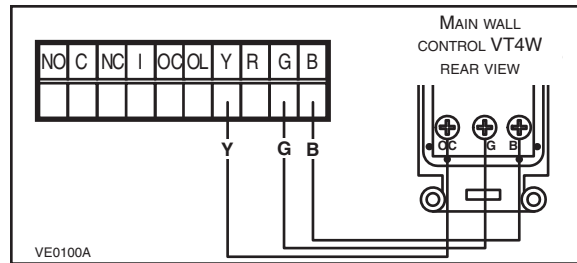

#### 4.2.2 ELECTRICAL CONNECTION TO OPTIONAL AUXILIARY WALL CONTROLS

NOTE: If an optional auxiliary wall control is activated and then, the Humidity Control is being activated, the Humidity Control will override the auxiliary wall control commands.

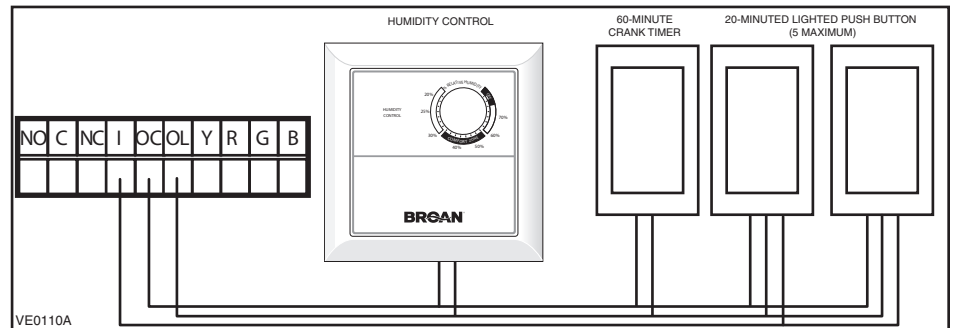

Once the wall control(s) connections have been made, insert the terminal connector in the bottom of the unit, on the electrical compartment front face.

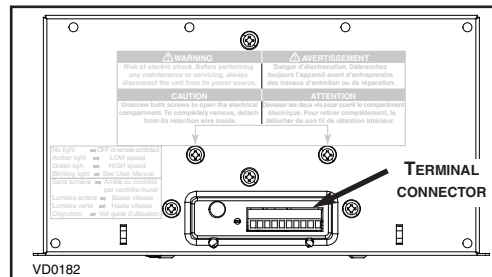

### 4.3 VT4W OPTIONAL MAIN WALL CONTROL OPERATION

COLOR	MODE	SUGGESTED USE
GREEN	INTERMITTENT	SELECT THIS MODE WHEN YOU ARE AWAY FROM THE HOUSE FOR A FEW DAYS. ALSO, WHEN YOU DEEM THE INSIDE AIR IS TOO DRY IN HEATING SEASON, OR TOO HUMID DURING COOLING SEASON. IN THIS MODE, THE UNIT IS OFF FOR 40 MINUTES PER HOUR AND VENTILATES AT MINIMUM SPEED THE REMAINING 20 MINUTES OF THE HOUR.
YELLOW	MIN SPEED VENTILATION	FOR NORMAL DAILY OPERATION.
RED	MAX SPEED VENTILATION	FOR EXCESS POLLUTANTS AND HUMIDITY (PARTIES, ODORS, SMOKE, ETC.).

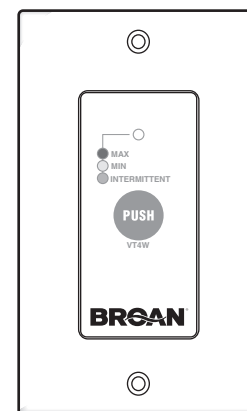

VC0070

## 4. CONTROLS (CONT'D)

### 4.4 OPTIONAL AUXILIARY WALL CONTROLS OPERATION

#### 4.4.1 20-MINUTE LIGHTED PUSH-BUTTON TIMER

Set the push-button timer to ON. The fan motors will then operate at high speed for 20 minutes and the indicator will light up.

To stop activation, push one time; the unit will then get back to previous selection.

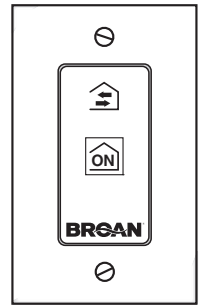

VC0084

#### 4.4.2 60-MINUTE CRANK TIMER

This control makes the system operate at high speed for periods varying from 10 to 60 minutes.

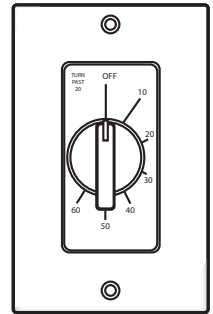

VC0017

#### 4.4.3 HUMIDITY CONTROL

Setting during the fall, winter and spring months:  
Adjust knob to the desired maximum humidity level.

Setting during summer:  
Adjust knob to the OFF position.

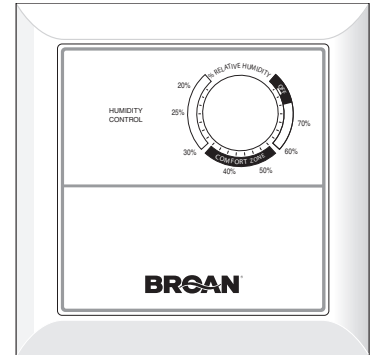

VC0085

### CAUTION

Do not select a humidity level below 30%. This could lead to excessive dryness in the air causing discomfort for the occupants.

## 5. ELECTRICAL CONNECTION TO THE FURNACE

### ⚠ WARNING

Never connect a 120-volt AC circuit to the terminals of the furnace interlock (standard wiring). Only use the low voltage class 2 circuit of the furnace blower control.

#### For a furnace connected to a cooling system:

On some older thermostats, energizing the "R" and "G" terminals at the furnace has the effect of energizing "Y" at the thermostat and thereby turning on the cooling system. If you identify this type of thermostat, you must use the alternate furnace interlock wiring.

#### Standard furnace interlock wiring

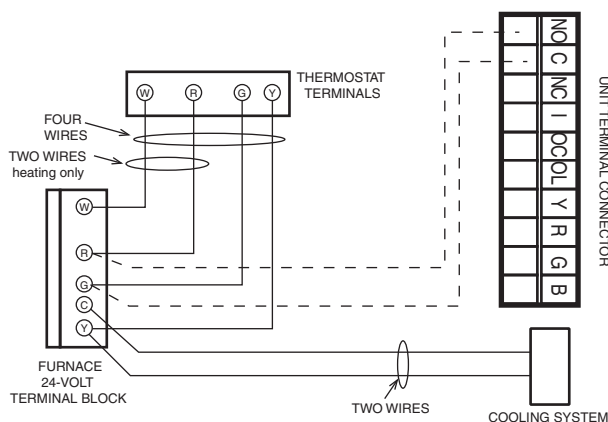

VE0108A

#### Alternate furnace interlock wiring

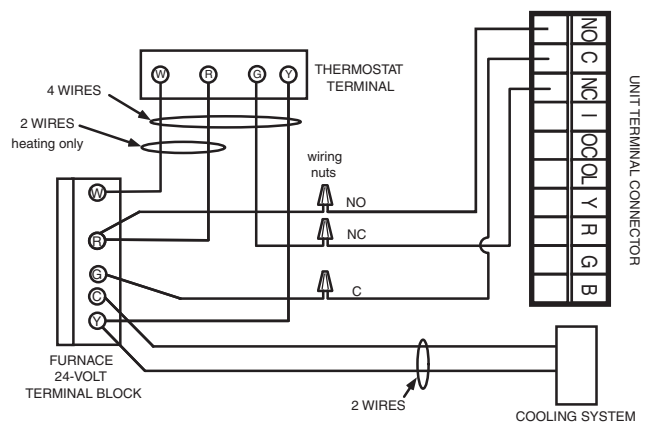

# 6. WIRING DIAGRAM



**WARNING**

Risk of electrical shocks. Before performing any maintenance or servicing, always disconnect the unit from its power source.

LOGIC DIAGRAM

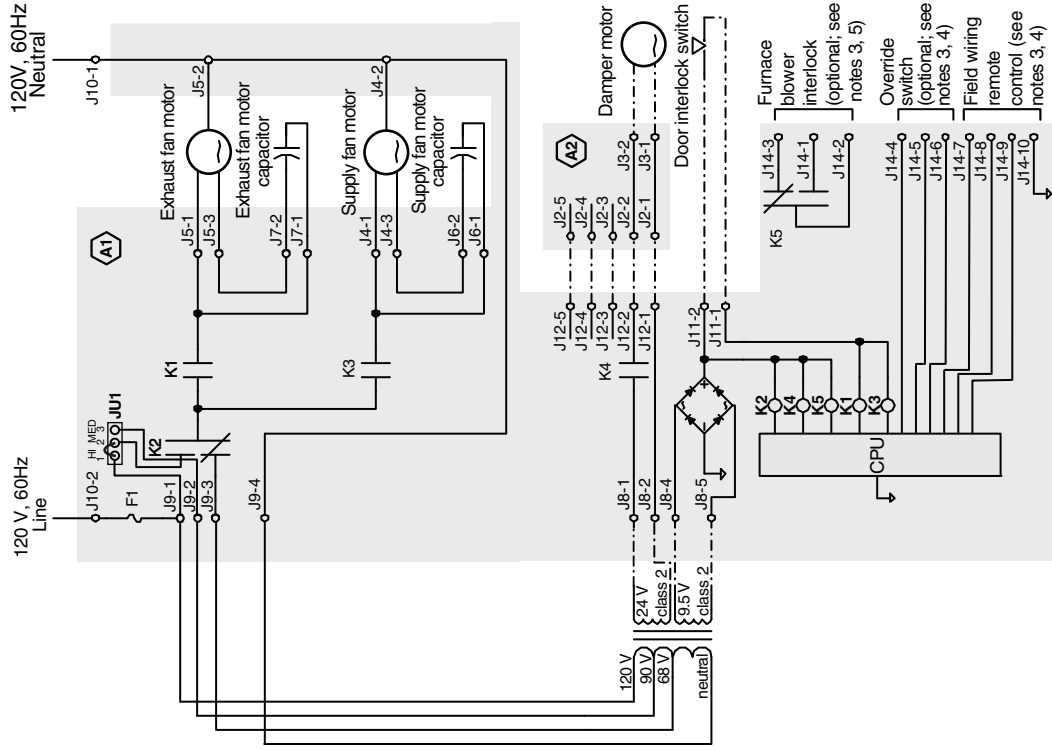

WIRING DIAGRAM

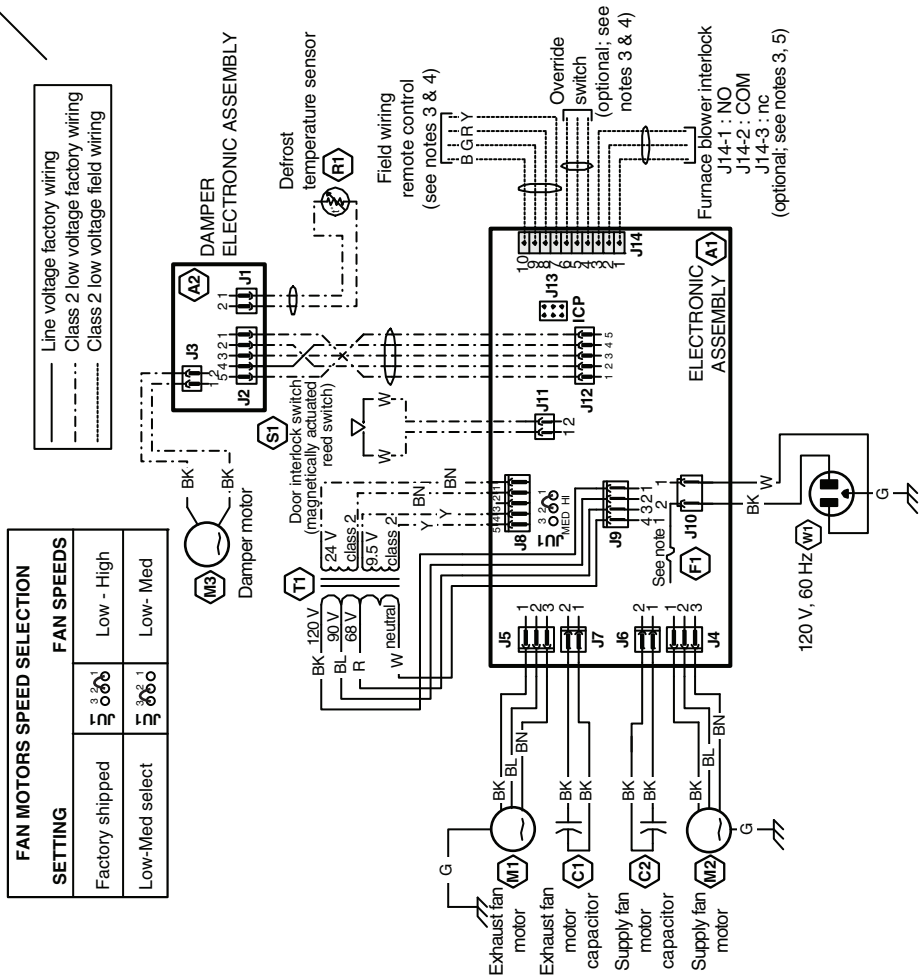

SETTING	FAN SPEEDS	
	Factory shipped	3 0 0
Low-Med select	3 0 0	Low - Med

**Critical characteristic.**

**COLOR CODE**

BK	BLACK
BL	BLUE
BN	BROWN
GR	GREEN
R	RED
W	WHITE
Y	YELLOW
nc	no connection

**NOTES**

- For continued fire protection. Use specified UL listed/CSA Certified line fuse.
- If any of the original wire, as supplied, must be replaced, use the same equivalent wire.
- Field wiring must comply with applicable codes, ordinances and regulations.
- Remote controls (class 2 circuit) available, see instruction manual.
- Furnace fan circuit must be class 2 circuit only.

## 7. BALANCING THE UNIT

To avoid balancing, the difference between stale air ducts total length and fresh air ducts total length must not exceed 50 ft. However, even if the stale air ducts and fresh air ducts lengths are almost equal, your local building codes may require balancing the unit.

If the unit does not need to be balanced, shut all the pressure taps (located on the unit door) with the small plastic plugs included in the hardware kit.

### 7.1 WHAT YOU NEED TO BALANCE THE UNIT

- A magnehelic gauge capable of measuring 0 inch to 0.5 inch of water (0 Pa to 125 Pa) and 2 plastic tubes.
- The balancing chart located on the unit door.

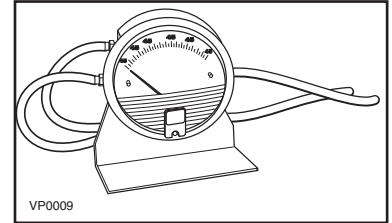

### 7.2 PRELIMINARY STAGES TO BALANCE THE UNIT

- Seal all the unit ductwork with tape. Close all windows and doors.
- Turn off all exhaust devices such as range hood, dryer and bathroom fans.
- Make sure the integrated balancing dampers are fully open. Turn the thumb screw (A) **clockwise** to manually open the dampers. Both are located on the Exhaust air to outside port and on Fresh air to building port.
- Make sure all filters are clean (if it is not the first time you balance the unit).

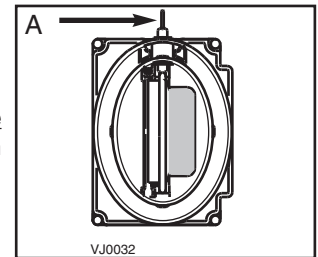

PORT WITH INTEGRATED BALANCING DAMPER - TOP VIEW

### 7.3 BALANCING PROCEDURE

#### 1. Set the unit to high speed.

Make sure that the furnace/air handler blower is ON if the installation is in any way connected to the ductwork of the cold air return. If not, leave furnace/air handler blower OFF. If the outside temperature is below 0°C / 32°F, make sure the unit is not running in defrost while balancing. (By waiting 10 minutes after plugging the unit in, you are assured that the unit is not in a defrost cycle.)

#### 2. Place the magnehelic gauge on a level surface and adjust it to zero.

#### 3. Connect tubing from gauge to EXHAUST air flow pressure taps (see diagram beside). Be sure to connect the tubes to their appropriate *high/low* fittings. If the gauge drops below zero, reverse the tubing connections.

NOTE: It is suggested to start with the exhaust air flow reading because the exhaust has typically more restriction than the fresh air, especially in cases of fully ducted installations or source point ventilation.

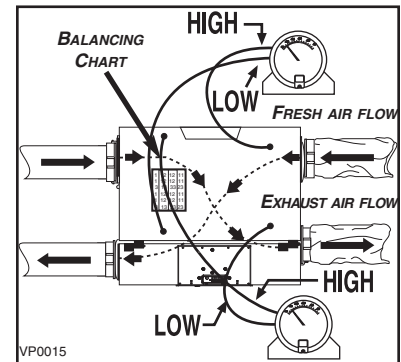

Place the magnehelic gauge upright and level. Record equivalent AIR FLOW of the reading according to the balancing chart.

#### 4. Move tubing to FRESH air flow pressure taps (see diagram). Adjust the fresh air balancing damper until the fresh air flow is approximately the same as the EXHAUST air flow. If fresh air flow is less than exhaust air flow, then go back and adjust the exhaust balancing damper to equal the fresh air flow.

#### 5. Secure both dampers thumb screw in place with tape.

#### 6. Write the required air flow information on a label and stick it near the unit for future reference (date, maximum speed air flows, your name, phone number and business address).

NOTE: The unit is considered balanced even if there is a difference of  $\pm 10$  cfm (or  $\pm 5$  l/s or 17 m<sup>3</sup>/h) between the two air flows.

## 8. CONNECTING THE DRAIN (HRV UNITS ONLY)

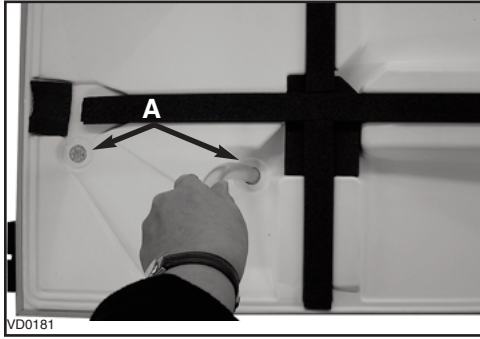

From the inner side of the unit door, using the provided drain tube, punch out both drain holes (A).

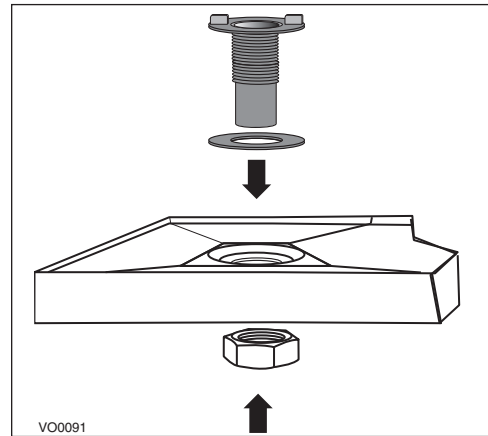

In order to keep the drain pan intact, hand tighten the 2 plastic drain fittings to the unit door using the gaskets and nuts as shown.

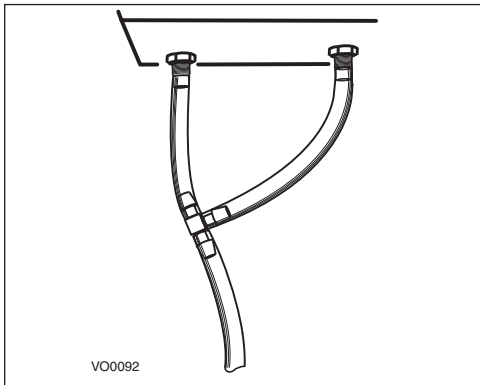

Cut 2 sections of plastic tubing, about 12" (305 mm) long and attach them to each drain fitting. Join the 2 short sections to the "T" junction and main tube as shown.

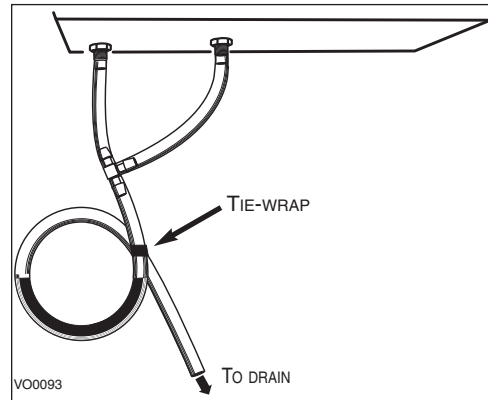

Make a water trap loop in the tube to prevent the unit from drawing unpleasant odors from the drain source. Make sure this loop is situated **BELOW** the "T" as shown. This will prevent water from being drawn back up into the unit in case of negative pressure. Run the tube to the floor drain or to an alternative drain pipe or pail. Be sure there is a slight slope for the run-off.

## 9. MAINTENANCE

### WARNING

**Risk of electrical shocks. Before performing any maintenance or servicing, always disconnect the unit from its power source.**

Since this guide covers both HRV and ERV units, top and side ports, the illustrations shown in the maintenance procedures are typical. The following procedures applies for both HRV and ERV units.

Refer to pictures below to identify the inner parts of your unit.

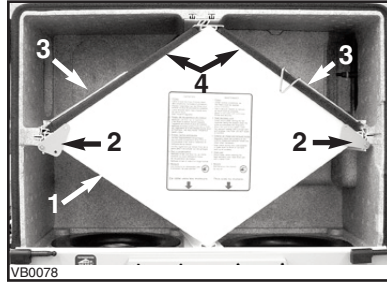

1) HRV CORE                      3) FOAM FILTER BRACKETS  
2) CORE RETAINERS          4) FOAM CORE FILTERS

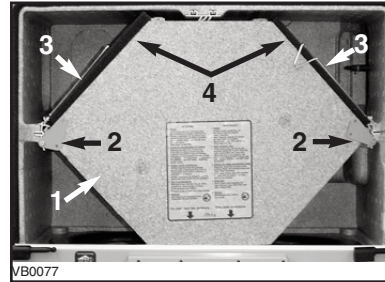

1) ERV CORE                      3) FOAM FILTER BRACKETS  
2) CORE RETAINERS          4) FOAM CORE FILTERS

### 9.1 SEMI-ANNUAL MAINTENANCE

1. Unplug the unit.

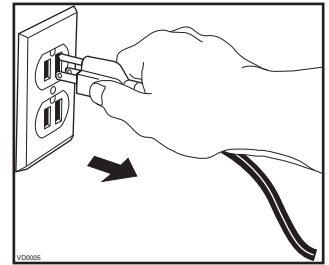

### WARNING

**Be careful before opening the door; water or small debris could fall out. For HRV unit, always wait one minute after disconnecting the unit before opening the door in order to allow water to drain out from the unit.**

2. Unlatch the door and open it. Clean the inner side of the door with a damp cloth, then wipe with a dry one. Disengage the door from its hinge by sliding it from left to right and set aside.

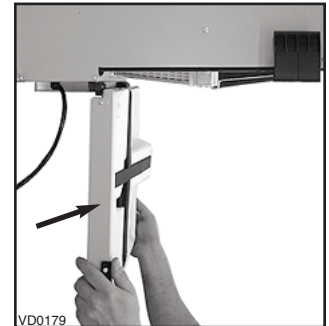

### WARNING

**Always hold the core when rotating the 2 core retainers; failure to do so will cause the core to fall out.**

3. Lift both foam filters bracket (1) and remove the foam filters from the core. While holding the core, rotate the 2 core retainers (2) and slide out the core from the unit.

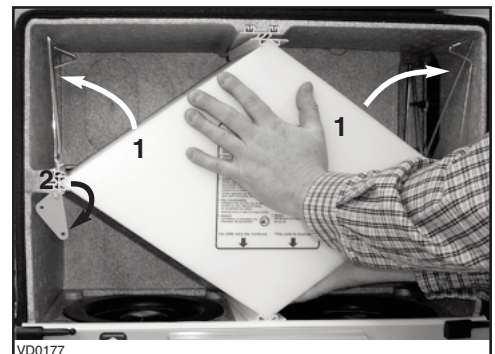

## 9. MAINTENANCE (CONT'D)

### 9.1 SEMI-ANNUAL MAINTENANCE (CONT'D)

4. Clean the inside walls of the unit with a clean damp cloth, then wipe with a clean dry one.
5. Wash the 2 core filters under hot water with mild soap. Rinse thoroughly and let dry completely before reinstalling on the core.
6. Remove the dust on the core using a vacuum cleaner and a soft brush attachment.

#### **WARNING**

**Once the core reinstalled in the unit, always rotate both core retainers to their initial position; failure to do so will cause the core to fall out.**

7. Slide the core in the unit. Secure the core by rotating both core retainers to their initial positions.

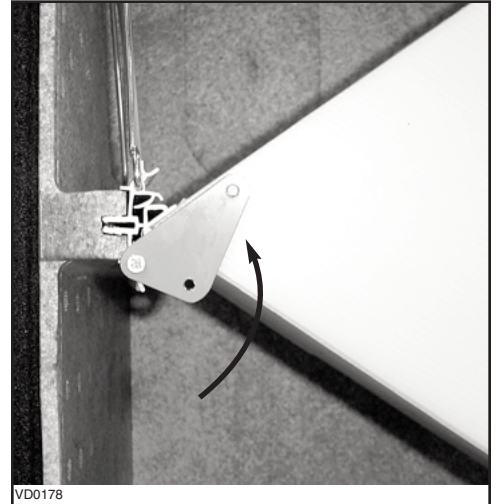

NOTE: Once the core reinstalled in the unit, the arrows (A) on its sticker label must be pointing towards the unit motors.

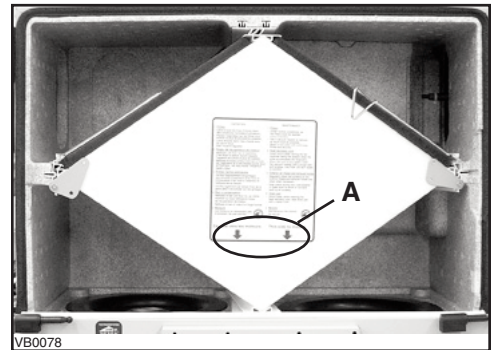

8. Reinstall both foam filters and secure them to the core by pulling down the 2 foam filter brackets. Reinstall the door.
9. Close the door and plug the unit.

NOTE: The unit will return to its previous setting after a 30-second delay for boot sequence.

### 9.2 ANNUAL MAINTENANCE

Do the same operations as the Semi-Annual Maintenance (*Section 9.1*). Then, clean the exterior hood(s).

## 10. SERVICE PARTS

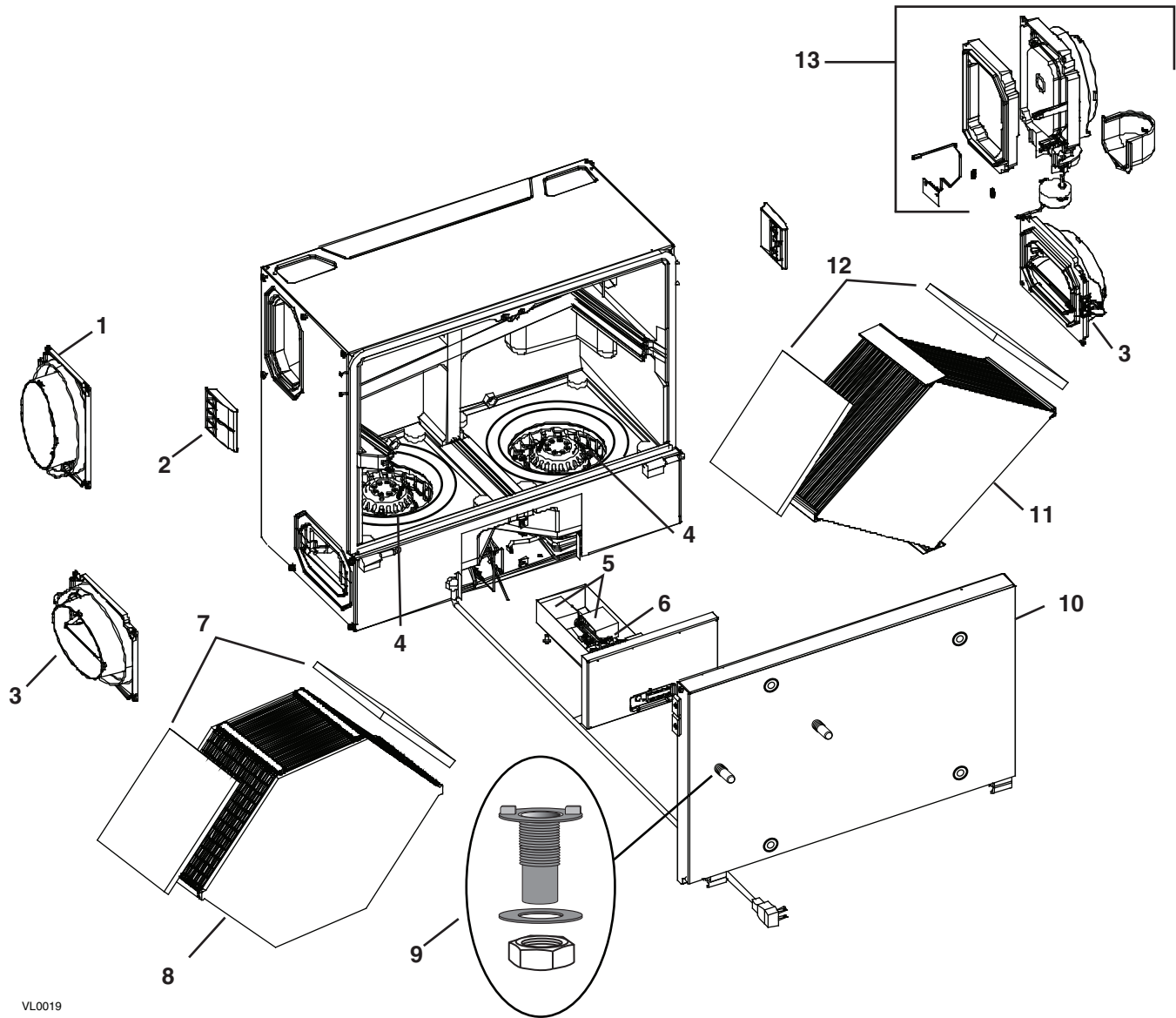

VL0019



ITEM	DESCRIPTION	PART NUMBER	HRV90HS (PORTS ON SIDES)	HRV90HT (PORTS ON TOP)	ERV90HCS (PORTS ON SIDES)	ERV90HCT (PORTS ON TOP)
1	OVAL PORT (FITS 5" DIAMETER DUCTS)	V16040	1	1	1	1
2	DOOR LATCH WITH SCREWS	V16035	2	2	2	2
3	OVAL PORT WITH INTEGRATED BALANCING DAMPER	V16041	2	2	2	2
4	MOTOR & WHEEL ASSEMBLY (MOTOR CAPACITOR AND INLET RING INCLUDED)	V16024	2	2	2	2
5	CAPACITOR 3 $\mu$ F	V17024	2	2	2	2
6	ELECTRONIC BOARD	V16038	1	1	1	1
7	ERV FOAM FILTER	V16031	N/A	N/A	2	2
8	ERV CORE (WITH 2 FILTERS)	V16037	N/A	N/A	1	1
9	DRAIN CONNECTOR KIT	V03203	1	1	N/A	N/A
10	DOOR ASS'Y	V16096	1	1	1	1
11	HRV CORE (WITH 2 FILTERS)	V16044	1	1	N/A	N/A
12	HRV FOAM FILTER	V16032	2	2	N/A	N/A
13	MOTORIZED DAMPER PORT ASS'Y	V16029	1	1	1	1
14*	TRANSFORMER	V16567	1	1	1	1
15*	GREEN TERMINAL BLOCK	V16416	1	1	1	1

\* PART NOT SHOWN.

# 11. TROUBLESHOOTING

If the integrated control LED of the unit is flashing, this means the unit sensors detected a problem. See the table below to know where on the unit the problem occurs.

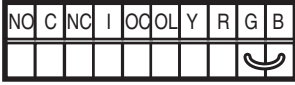
- |                    |   |  |
|--------------------|---|--|
| LED flashes GREEN. | • Thermistor error.                               | Replace the entire port assembly (fresh air from outside port).                        |
| LED flashes AMBER. | • Damper error.                                   | Go to Point 6.   |
| LED flashes RED.   | • The door is open and the unit is not unplugged. | Close the door and press once on the integrated control push button to reset the unit. |
|                    | • Exhaust motor error.                            | Go to Point 5.   |

Problems	Possible causes	You should try this
1. Unit does not work.	<ul style="list-style-type: none"> <li>The circuit board may be defective.</li> </ul>	<ul style="list-style-type: none"> <li>Unplug the unit. Disconnect the main control and the auxiliary control(s) (if need be). Jump G and B terminals. Plug the unit back and wait about 10 seconds. If the motors run on high speed and the damper opens, the circuit board is not defective.</li> </ul>  <p style="text-align: right; font-size: small;">VE0097</p>
2. The damper actuator does not work.	<ul style="list-style-type: none"> <li>The damper actuator or the integrated damper port mechanism may be defective.</li> <li>The circuit board may be defective.</li> </ul>	<ul style="list-style-type: none"> <li>Unplug the unit. Disconnect the main control and the optional control(s) (if need be). Wait 10 seconds and plug the unit back. Check if the damper opens. If not, use a multimeter and check for 24V AC on J12-1 and J12-2 (in electrical compartment). If there is 24V AC, replace the entire port assembly.</li> <li>NOTE: It is normal to experience a small delay (7-8 seconds) before detecting the 24V AC signal at starting-up. This signal will stay during 17-18 seconds before disappearing.</li> <li>If there is no 24V AC, replace the circuit board.</li> </ul>
3. The wall control does not work OR the indicators flash.	<ul style="list-style-type: none"> <li>The wires may be in reverse position.</li> <li>The wires may be broken.</li> <li>The wire in the wall OR the wall control may be defective.</li> </ul>	<ul style="list-style-type: none"> <li>Ensure that the color coded wires have been connected to their appropriate places.</li> <li>Inspect every wire and replace any that are damaged.</li> <li>Remove the wall control and test it right beside the unit using another shorter wire. If the wall control works there, change the wire. If it does not, change the wall control.</li> </ul>
4. The Humidity Control does not work OR the 20-minute push-button timer does not work OR its indicator light does not stay on.	<ul style="list-style-type: none"> <li>The wires may be in reverse position.</li> <li>The Humidity Control or push button may be defective.</li> </ul>	<ul style="list-style-type: none"> <li>Ensure that the color coded wires have been connected to their appropriate places.</li> <li>Jump the OL and OC terminals. If the unit switches to high speed, remove the Humidity Control or push button and test it right beside the unit using another shorter wire. If it works here, change the wire. If it doesn't, change the Humidity Control or the push button.</li> </ul>  <p style="text-align: right; font-size: small;">VE0098</p>
5. The supply and/or exhaust motor do not work.	<ul style="list-style-type: none"> <li>The circuit board may be defective.</li> <li>The motor(s) may be defective.</li> </ul>	<ul style="list-style-type: none"> <li>Press on the integrated control push button until the unit turn on low speed (the LED will light AMBER). Using a multimeter, check the voltage on J4-1 and J4-2 (for supply motor), and on J5-1 and J5-2 (for exhaust motor). The reading must be <math>\pm 68</math> V AC. Then set the unit on high speed by pressing on the integrated control 1 more time (the LED will light GREEN). Using a multimeter, check the voltage on J4-1 and J4-2 (for supply motor), and on J5-1 and J5-2 (for exhaust motor). The reading must be <math>\pm 120</math> V AC if the fan motor speed setting is Low-High, or <math>\pm 90</math> V AC if the fan motor speed setting is Low-Medium. If all the readings correspond to the right voltage values, the circuit board is not defective. If one or both readings are different, change the circuit board.</li> <li>Using a multimeter, check the ohms value on each motor connectors. For BLUE and BLACK motor wires, the right value is <math>\pm 52</math> ohms. For BLUE and BROWN motor wires, the right value is <math>\pm 72</math> ohms. For BROWN and BLACK motor wires, the right value is <math>\pm 124</math> ohms. If the ohm values are the same, the motor is not defective. Replace the motor capacitor.</li> </ul>
6. The defrost cycle does not work (the fresh air duct is frozen OR the fresh air distributed is very cold).	<ul style="list-style-type: none"> <li>Ice deposits may be hindering the damper operation.</li> <li>The damper rod or the port damper itself may be broken.</li> <li>The damper actuator or circuit board may be defective.</li> </ul>	<ul style="list-style-type: none"> <li>Remove the ice.</li> <li>Inspect these parts and replace if necessary.</li> <li>See point 2.</li> </ul>
7. The integrated control push button does not work.	<ul style="list-style-type: none"> <li>The 30-second boot sequence is not completed.</li> </ul>	<ul style="list-style-type: none"> <li>See <i>Section 4.1.1 Boot Sequence</i>.</li> </ul>