

MODELS 1050L & 1051L TRASH COMPACTOR

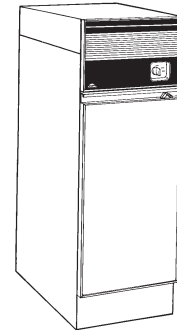

All of Broan's industry-leading features plus a drawer latch - meets all your installation requirements.

FEATURES

- Up to 5000 lbs. of compacting force
- Patented double scissors ram
- Compacts the equivalent of fourteen (14) 13-gallon trash containers into one easy, disposable bag
- Space-saving 12" wide design
- Key operated switch for safety
- Convenient swing open door for trash unloading
- Bag storage compartment
- Air Scentry™ - accepts most popular solid deodorizers with self adhesive
- Four adjustable leveling legs
- Door panels offer choice of two decorative finishes:
Black/Biscuit – Model 1050L
Black/White – Model 1051L
- Textured cabinet features a durable baked enamel finish in Black
- Safety latch - keeps drawer locked when closed
- **No. 93620008** reinforced plastic replacement bags (available twelve (12) to a pack)
- **Model 1004** Hardwood cutting board top (available separately)

SPECIFICATIONS

| VOLTS | Hz | AMPS | CAPACITY | COMPACTION | WEIGHT |
|-------|----|------|-----------------|-----------------|-------------------------|
| 120 | 60 | 5.0 | 1.4 cu. ft. bin | Up to 5000 lbs. | 134 lbs. (incl. carton) |

TYPICAL SPECIFICATION

Trash compactor shall be Broan Model 1050L (Model 1051L).

Unit shall produce up to 5000 lbs. of compacting force.

Compactor shall be 12" wide and installed (flush with countertop) (freestanding). Door panels to be interchangeable with two different color choices.

Unit shall have to a key switch and a deodorizing panel feature, and drawer latch.

Compactor to operate on 120 VAC, 60 Hz and not to exceed 5 AMPS. Unit to be U.L. listed.

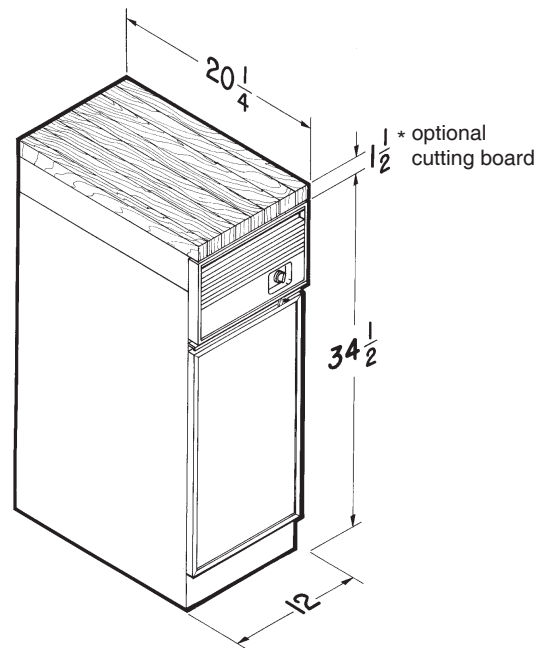

Broan-NuTone LLC, 926 West State Street, Hartford, WI 53027 (1-800-637-1453)

| REFERENCE | QTY. | REMARKS | Project |
|-----------|------|---------|--|
| | | | Location |
| | | | Architect |
| | | | Engineer |
| | | | Contractor |
| | | | Submitted by Date |