

MODELS 1055 & 1059 TRASH COMPACTOR

MODEL 1055 BLACK
MODEL 1059 WHITE

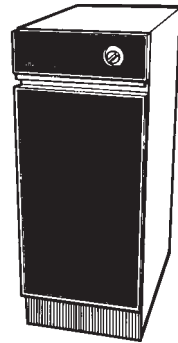

The same powerful mechanism used in our deluxe compactors - in a space-saving housing with drawer latch.

FEATURES

- Up to 5000 lbs. of compacting force
- Patented double scissors ram
- Compacts the equivalent of fourteen (14) 13-gallon trash containers into one easy, disposable bag
- Key operated switch for safety
- Space-saving 12" wide design
- Convenient swing open door for trash unloading
- Air Scentry™ - accepts most popular solid deodorizers with self adhesive
- Four adjustable leveling legs
- Reversible door panels offer choice of colors:
Black/Biscuit – Model 1055
Black/White – Model 1059
- Safety latch – keeps drawer locked when closed
- **No. 93620008** reinforced plastic replacement bags (available twelve (12) to a pack)
- **Model 1004** Hardwood cutting board top (available separately)

SPECIFICATIONS

VOLTS	Hz	AMPS	CAPACITY	COMPACTION	WEIGHT
120	60	5.0	1.4 cu. ft. bin	Up to 5000 lbs.	128 lbs. (incl. carton)

TYPICAL SPECIFICATION

Trash compactor shall be Broan Model 1055 (Model 1059). Unit shall produce up to 5000 lbs. of compacting force. Compactor shall be 12" wide and installed (under countertop) (freestanding). Door panels to offer two color choices. Unit shall have a key switch, a deodorizing panel feature and drawer latch. Compactor to operate on 120 VAC, 60 Hz and not to exceed 5 AMPS. Unit to be U.L. listed.

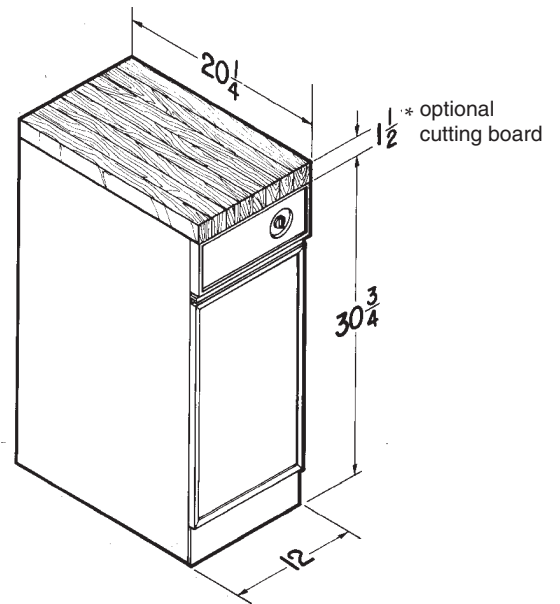

Broan-NuTone LLC, 926 West State Street, Hartford, WI 53027 (1-800-637-1453)

REFERENCE	QTY.	REMARKS	Project
			Location
			Architect
			Engineer
			Contractor
			Submitted by Date