

Trash Compactor Installation, Use & Care Guide

READ AND SAVE THESE INSTRUCTIONS

IMPORTANT SAFEGUARDS

READ ALL INSTRUCTIONS CAREFULLY BEFORE OPERATING COMPACTOR.

Basic precautions should always be taken when using an electrical appliance – including the following:

1. Close supervision is necessary when any appliance is operated near children. Do not allow the appliance to be used as a toy, or to run unattended at any time. Turn key to “OFF” and remove it to lock the compactor. Store the key out of reach to prevent children or others from operating or tampering with the compactor.
2. Do not push trash into compactor drawer with hands or feet. Trash might contain broken glass, sharp pieces of metal, etc., which would cause injury.
3. Do not compact volatile material. Paint, oily rags, lighter fluid cans, and paint thinner cans could combust spontaneously and cause an explosion and/or fire.
4. Do not compact aerosol cans or any other containers still holding toxic chemicals, insecticides, or combustible contents. Fumes may be released which are hazardous to health.
5. Do not compact lighted cigarettes, cigars, or other hot or burning items.
6. Do not overload the compactor.
7. Be careful when removing and carrying bag. Broken glass or other sharp objects may pierce bag. Do not overload trash bag with heavy material such as glass.
8. Do not operate this unit with an extension cord.
9. Use only Broan approved accessories.
10. Do not touch moving parts.
11. Do not take this appliance apart. Incorrect reassembly can cause electrical shock when operated.
12. Do not operate with a damaged power cord, plug, motor, or after damage of any kind. Have the compactor examined, and all repairs made, by an authorized serviceman.
13. This compactor is FOR HOUSEHOLD USE ONLY. Use it only as described in this manual.
14. Unplug the appliance from outlet before servicing.

GROUNDING INSTRUCTIONS

IMPORTANT: TO REDUCE THE RISK OF ELECTRIC SHOCK - PLEASE READ CAREFULLY.

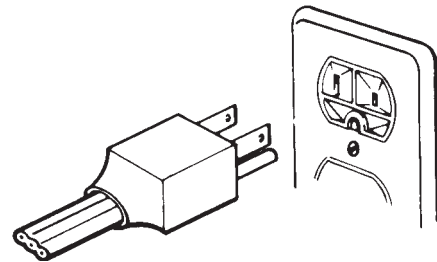

FOR PERSONAL SAFETY, THIS APPLIANCE MUST BE PROPERLY GROUNDED. The power cord on this appliance is equipped with a three-prong (grounding) plug which mates with a standard three-prong (grounded) receptacle as illustrated above.

If there is a two-prong outlet located where you will install the compactor, it is your responsibility to have it replaced with a properly grounded three-prong wall receptacle. No adapter shall be used with this product.

DO NOT, UNDER ANY CIRCUMSTANCES, CUT OR REMOVE THE THIRD (GROUND) PRONG FROM THE POWER CORD PLUG.

The GREEN (or GREEN & YELLOW) conductor in the cord is the grounding wire. Never connect the GREEN (or GREEN & YELLOW) wire to a live terminal.

A 120 volt, 60 Hz., A.C., 15 amp fused and grounded electrical supply is required (time-delay fuse or circuit breaker is recommended). It is recommended that a SEPARATE CIRCUIT serving only this appliance be provided.

DO NOT USE AN EXTENSION CORD WITH THIS APPLIANCE.

TABLE OF CONTENTS

SECTION	PAGE
INSTALLATION	
Unpacking the Trash Compactor	2
Free Standing	2
Built-in Installations	2
Leveling the Compactor	3
Reversing the Door (optional)	3, 4
Tile and Wood Door Assembly	4
PREPARATION	
1. How the Compactor Works	5
2. Use of Key Lock Switch	6
3. Install Odor Control Disk	6
4. Install Bag	6
5. Cutting Board (optional)	6
OPERATION	
6. Compacting	7
7. Clock / Auto Delay	7
8. Battery Backup	7
9. Compacting Tips	8
10. Bag Removal	8
MAINTENANCE	
11. Cleaning	8, 9
12. Troubleshooting	10
13. Warranty	10

UNPACKING THE TRASH COMPACTOR

The trash compactor is shipped from the factory with packing material in the trash bucket and the ram in the down position. Return the ram to the up position by plugging the unit in, turning the key lock switch to the "ON" position and closing the door. Once the door is closed the unit will run and the ram will travel to the "UP" position. Open the trash bucket and remove the packing material.

Your Broan Elite Compactor has been designed to require minimum space without loss of capacity whether free-standing or built-in.

FREE-STANDING

As shipped, the Compactor is only configured for built in installations. This appliance can be converted from built-in to free-standing with the use of Toe Kick Accessory Kit Model 15TCTK (sold separately). If additional cord length is required for free-standing installation, remove the cord clamp and wire tie on the back of the unit.

CAUTION: Failure to use Toe Kick Accessory Kit Model 15TCTK in a free-standing installation may cause the compactor to be unstable during operation.

BUILT-IN INSTALLATIONS

MOUNTING STRAPS

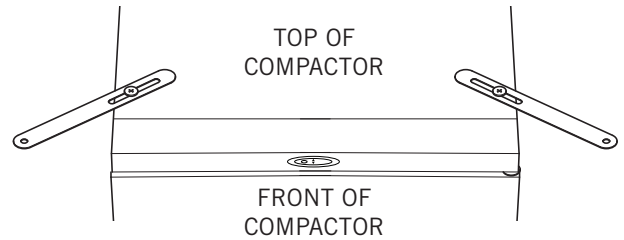

Two under-counter mounting straps are provided. Use these straps to secure the compactor to the underside of a countertop. Fasten the slotted end of the straps to the compactor using the holes in the top of the compactor cabinet as shown.

NOTE: When installing compactor under granite or solid-surface countertops, bend the mounting straps so they can be secured to the adjacent cabinetry.

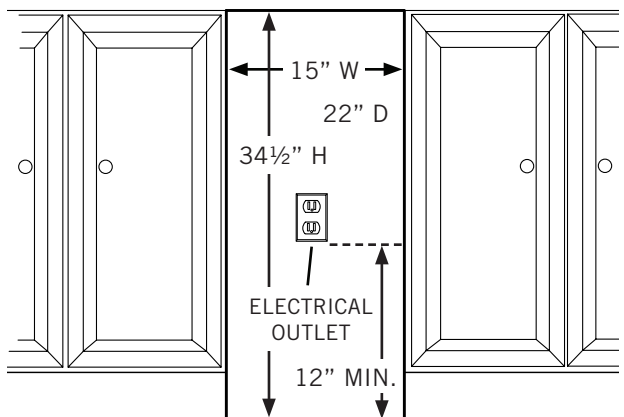

UNDER-COUNTER OPENING

The compactor requires a minimum under-counter opening 15-in. wide, 34½-in. high, and 22-in. deep.

Plan to provide an electrical outlet in the opening that meets all applicable electrical codes and requirements. See "Grounding Instructions" section on Page 1 for specific information.

CORD CLAMP

The compactor is equipped with a 6-ft. long power cord. Use the cord clamp to prevent excess power cord from being pinched beneath the cabinet during installation or service.

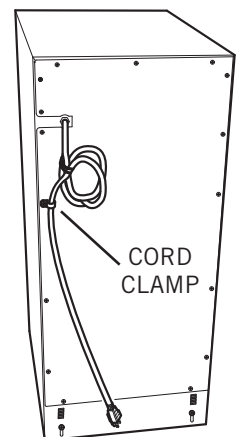

LEVELING THE COMPACTOR

Your compactor has four adjustable levelers; (2) rollers in the rear and (2) legs in the front. They allow you to adjust for uneven floors and also trim the unit up to fit an under-counter installation.

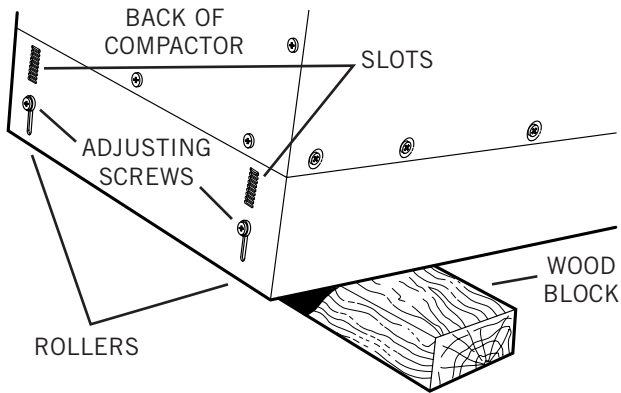

To level the back of the compactor:

Tip the **back of compactor** up and onto a **wood block**. Loosen the **adjusting screws** only far enough to move the **rollers** to a higher or lower **slot**. Retighten the adjusting screws and remove the wood block.

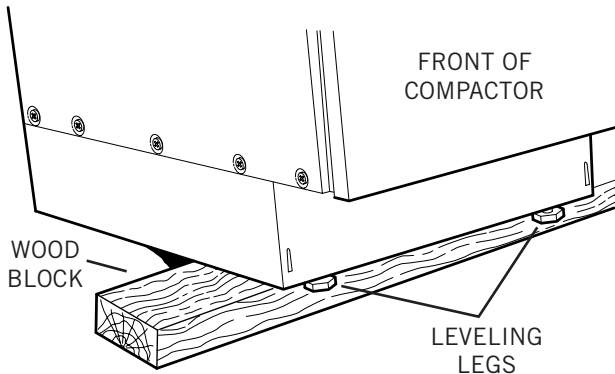

To level the front of the compactor:

Tip the **front of compactor** up and onto a **wood block**. Turn the **leveling legs** in or out to the desired position. Remove the wood block.

REVERSING THE DOOR (optional)

Door Reversal Instructions for all doors (except wood and tile).

As shipped, the compactor door is hinged on the right (when looking at the unit).

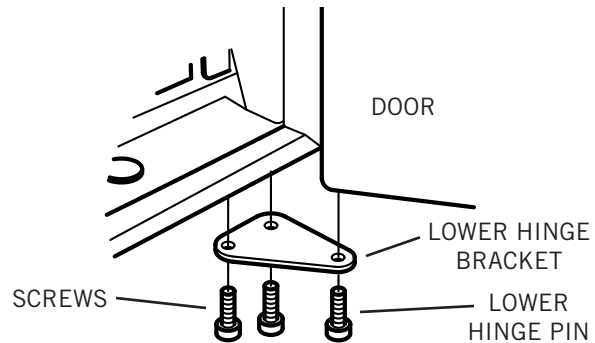

To change door to be hinged on the left:

1. With the door closed, use a 3/16" allen wrench to remove the **lower hinge pin**.
2. Carefully remove **door** by opening and sliding the bottom of the door away from the cabinet.
3. Use a 3/16" allen wrench to remove the **lower hinge bracket** from the cabinet (2 **screws**).

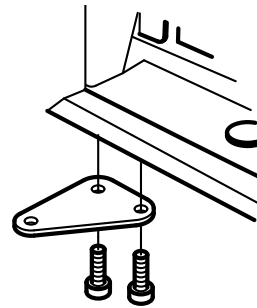

4. **Turn the bracket over** and install the bracket on the opposite side of the cabinet using the same screws.

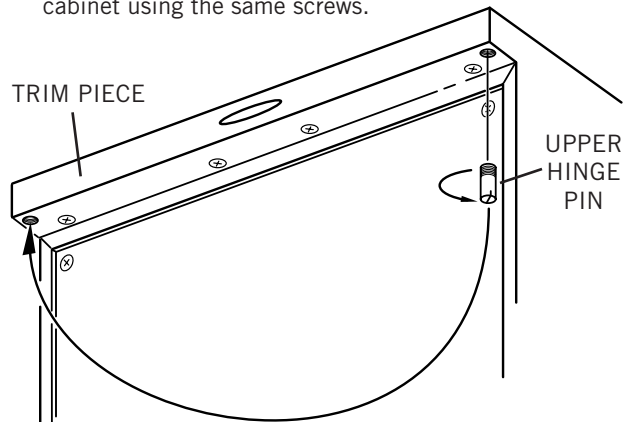

5. Use a screwdriver to remove the **upper hinge pin** from the **trim piece** and reinstall the pin on the opposite side.

Installation

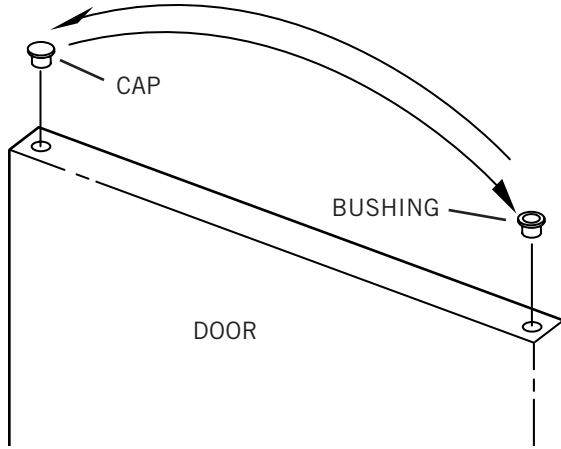

- Being careful not to scratch the **door**, remove the plastic door **bushing** and **cap** from the top and bottom of the door using a small flat screwdriver. Install the bushings on the side of the door panel that will be hinged and install the cap on the opposite side.
- Install the door on the cabinet by inserting the upper hinge pin into the upper door bushing while moving the door into place. Insert the lower hinge pin from Step 1 and tighten securely.

TILE AND WOOD DOOR ASSEMBLY

Use the following instructions if you have a trash compactor with a tile or wood door kit.

It is recommended you remove the door pan from the compactor to install the custom tile or wood panel.

To remove door pan:

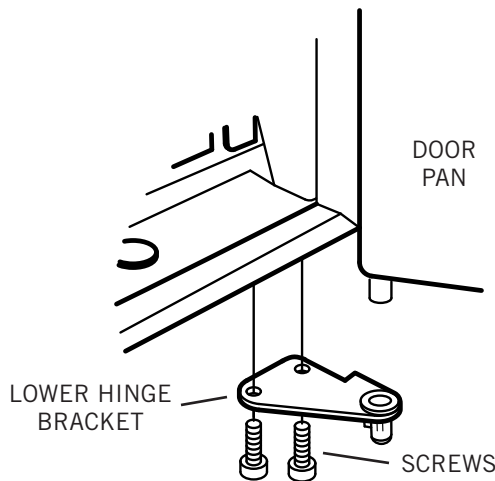

- Use a 3/16" allen wrench to remove the **lower hinge bracket** from the cabinet (2 **screws**).
- Remove the **door pan** from the cabinet.

- Consider where the compactor will be installed and determine whether to hinge the door on the left or right side of the cabinet. Since the hinge pins are permanently attached to the door pan, simply rotate the door pan until the hinge pins are on the desired side. You may want to mark the inside of the door pan to indicate the top.

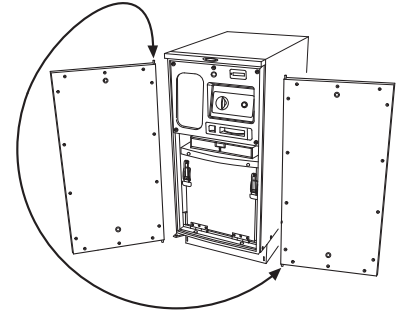

- To prevent damage to the **actuator** on the **back of door**, remove the (2) screws that hold it in place. Save the actuator and screws.

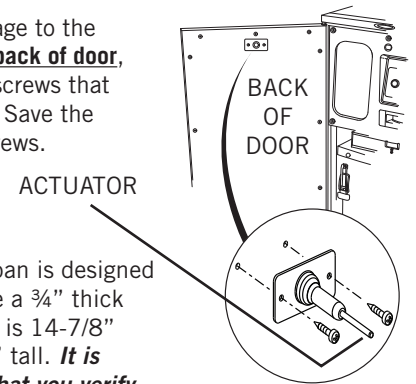

For wood door:

- The wood door pan is designed to accommodate a 3/4" thick wood panel that is 14-7/8" wide by 29-1/4" tall. **It is recommended that you verify the height of the door pan prior to cutting the wood panel to size.**

Center the door pan on the wood panel and fasten together using hardware provided in the compactor parts bag.

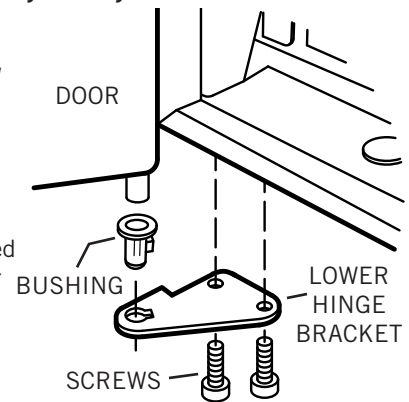

For tile door:

- The tile door pan comes preassembled with cement backer board. Tile and grout the door pan using traditional tiling methods and materials.
- Purchase a door handle to match your cabinet hardware and install per handle instructions.
- If the door will be hinged on the left side of the compactor, it will be necessary to reverse the **lower hinge bracket** removed in Step 1. Remove the plastic **bushing** from the hinge bracket and install on the opposite side of the bracket. Install the **door** onto the compactor cabinet by reversing the procedure from Step 1.
- Re-install the **actuator** removed in Step 4. Make sure the door opens and closes smoothly with the actuator entering and exiting the door interlock switch on the compactor.

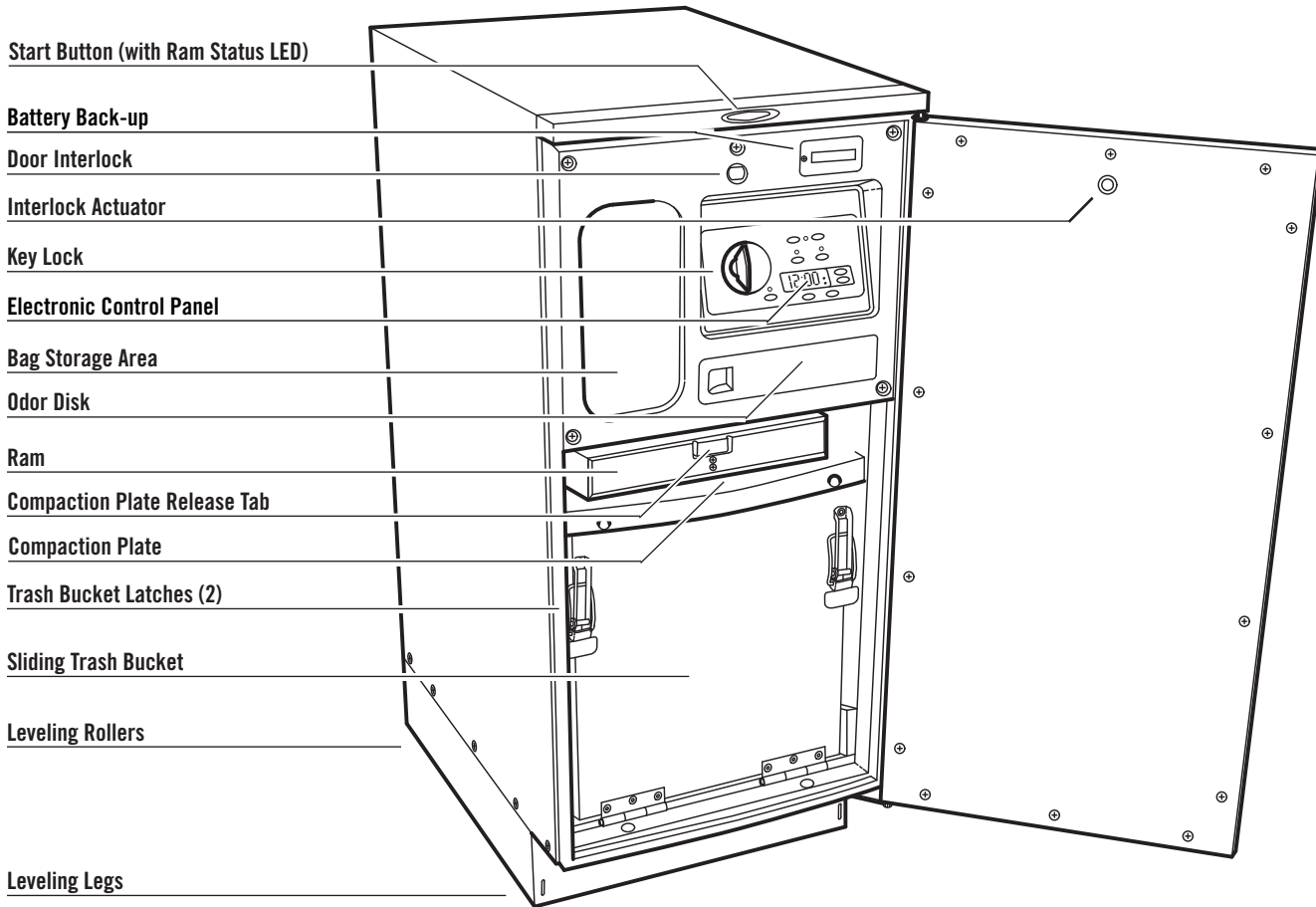

1. HOW THE COMPACTOR WORKS

The Broan Elite compactor compresses household trash up to 1/6 of its original volume. It will compact normal household trash including milk cartons, glass and plastic bottles, containers and jars, tin cans, wrappings, boxes, food wastes, etc.

When you start the compactor, an electrically powered ram moves down into the trash bucket, compresses the trash and then returns to the “UP” position and shuts off automatically.

NOTE: The ram travels about 2/3 of the way down into the trash bucket. Because of this, the trash bucket must be at least 1/3 full before you will notice any compression.

2. USE OF KEY LOCK SWITCH

The key lock switch on your compactor is provided for your protection as a safety measure.

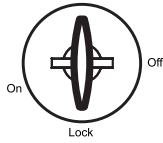

When the key lock switch is in the "OFF" and "LOCK" positions, the compactor will not operate. Remove the key to keep children from operating the unit or to prevent anyone from tampering with it.

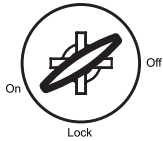

When the key lock switch is in the "ON" position, the compactor is ready for operation. The key cannot be removed when in the "ON" position.

NOTE: Opening the door during operation will stop the unit. If the compactor is stopped during its cycle, it will always move back UP when the door is closed.

3. INSTALL ODOR CONTROL DISK

Your Compactor is equipped with an odor control disk that will last up to six months when installed in the trash compactor. The odor disk comes packaged in a foil pouch and is activated once the pouch is opened. The compactor has an electronic control that automatically advances the odor disk every 30 days until 6 months have expired.

Optional – You may write dates on the odor disk labels in this manner:

- When pouch is opened, write the "Activation Date" on top of disk in space provided.
- Write dates on the GREEN month indicator labels in this manner:
Month 1 Label "Advance Date" = 1 month from "Activation Date"
Month 2 Label "Advance Date" = 2 months from "Activation Date"
Month 3 Label "Advance Date" = 3 months from "Activation Date"
Month 4 Label "Advance Date" = 4 months from "Activation Date"
Month 5 Label "Advance Date" = 5 months from "Activation Date"
- Write date on the RED month indicator label in this manner:
Month 6 Label "Replacement Date" = 6 months from "Activation Date"

Caution: The odor control disk contains material that may cause moderate eye irritation. Avoid contact with eyes. Harmful if swallowed. Wash skin or clothing thoroughly with soap and water after handling. Do not reuse empty foil pouch.

1. Remove the disk from the foil envelope, swing open the odor disk door, and place disk face down on tray. Make sure green label that says "Month 1" faces odor disk door.

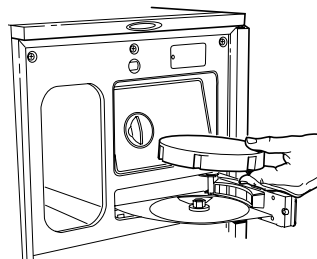

2. Press "Reset" to start the timer. The **odor status LED** will be GREEN.

3. The disk will advance to the next month after 30 days have passed or by pressing "Advance". Once the disk advances, the next 30 day period begins.

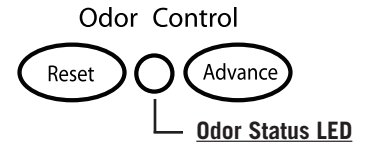

4. At the conclusion of the 5th month the **odor status LED** will FLASH GREEN to signal the disk is on its last month.
5. At the conclusion of the 6th month the **odor status LED** will turn RED to signal the disk must be replaced.
6. Discard the used disk in the trash, insert a new disk and press "Reset".

Odor disk, Model 15TCOD, is available from your Broan Distributor.

4. INSTALL BAG

With the door open and the trash bucket extended to the furthest position, place a bag into the bucket. Fold the bag over the top rim of the bucket, on all sides.

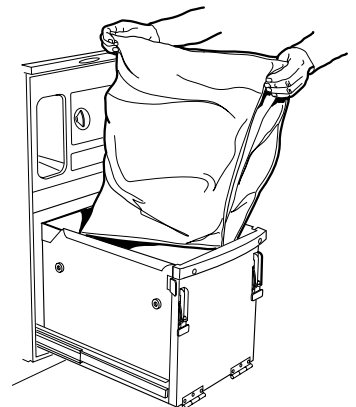

Press the bag into all corners of the bucket and smooth the bottom.

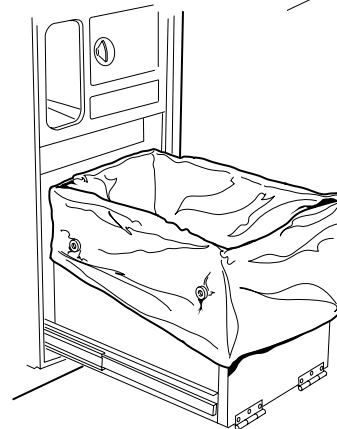

Smooth and shape the bag carefully - this will prevent the bag from being torn by the ram during compaction.

Secure the bag in place over the 2 buttons on each side of the bucket. The bag has prepunched slots for this purpose.

5. CUTTING BOARD (optional)

If your compactor will not be installed under a counter - you can order an optional cutting board, Model 15TCBB, from your Broan Distributor.

The cutting board rests on the top of the compactor, and features non-marring rubber feet and a gravy groove on the top.

To keep your wood cutting board from warping, wash with a mild detergent and apply a thin coat of mineral oil.

6. COMPACTING

The compactor is now ready to use.



FOR BEST RESULTS, ALWAYS FILL EACH NEW BAG COMPLETELY BEFORE OPERATING THE COMPACTOR. DOING SO WILL MINIMIZE BAG PULL-UP AND TEARING.

1. Slide trash bucket closed completely.
2. Turn Key Lock Switch to "ON" position.



3. Select 1 of 2 compact modes:

Compact Mode **Normal Compact Mode**

Hold Normal

After door is closed and "Start" button is pressed - ram will travel downward into trash bucket and compact trash. At bottom of ram stroke, ram automatically reverses and moves upward out of trash bucket. Total cycle time will be 45 seconds or less. At top of stroke, compactor automatically shuts itself off and is ready to receive more trash.

Compact Mode **Hold Compact Mode**

Hold Normal

After door is closed and "Start" button is pressed - ram will travel downward into trash bucket and compact trash. At bottom of ram stroke, ram will shut off. This setting is helpful for compressing trash completely to allow for greater capacity. Press "Start" button again to reverse ram upward out of trash bucket. At top of stroke, compactor automatically shuts itself off and is ready to receive more trash.

4. Close door.
5. Press "Start" button at top-center of unit to begin compacting. Compactor will automatically shut itself off when compaction cycle is completed. "Ram Status LED" is GREEN when ram is in up position and ready to receive trash. LED will turn RED when ram is moving or stopped in any other position.



6. Compacting cycle may be stopped at any time by opening door. Once stopped, ram will always move upward when door is closed.

7. CLOCK / AUTO DELAY



The compactor is equipped with an auto delay/clock feature that allows you to compact your trash at a time of your choice (such as every evening).

1. **To set clock time:**
Press and hold "Clock" set button until display flashes. Use the up and down arrows to set current time.
2. **To set auto delay time:**
Press and hold "Set Auto Delay" button until clock display flashes. Use Up / Down Arrows to set auto delay time. Press "Set Auto Delay" button again to display current time.
3. **To activate auto delay:**
Press "Auto Delay" button. LED above button will light and clock display will show auto delay time. Once clock reaches auto delay time, ram will compact and hold trash for 2 hours, then return to previous position.
4. **To interrupt auto delay during 2-hour hold period:**
Press "Start" button. Ram will return to UP position and stop. Open door to add additional trash to bucket. Close door and ram will return to hold position for remainder of 2-hour hold period.
5. **To cancel auto delay:**
Press "Auto Delay" button. Ram will return to previous position.

Operation

8. BATTERY BACKUP

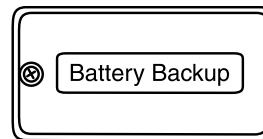

The compactor is equipped with a battery backup, to maintain clock settings in the event of a loss of power to the unit.

Remove the battery cover and install a 9-Volt battery (not included).

NOTE: The battery backup will not provide power to operate ram.

EXCEPT FOR CLEANING DESCRIBED IN THE FOLLOWING SECTION, ALL SERVICE SHALL BE PERFORMED BY AN AUTHORIZED SERVICE REPRESENTATIVE.

9. COMPACTING TIPS

- Although it is not necessary to compact until the drawer is full or nearly so, it is suggested that for maximum compaction, you start the compactor each time a significant amount of trash is added.
- At full stroke, the ram does not travel all the way to the bottom of the trash bucket. Trash in the bottom 1/3 of the bucket will be crushed during subsequent compacting.
- Glass bottles can make a loud noise when they break during compaction. This is normal. Bottles do not always break during the first cycle. Breaking glass and associated noise may occur several cycles later depending on type and volume of trash.
- Bottles and large cans compact best when laid flat near the center of the trash bucket.
- Place a couple of folded sheets of newspaper, or a large paper grocery bag on top of the load to be compacted when :
 - compacting large or several glass bottles or jars (or any items that might shatter). This will help prevent glass fragments and particles from flying out of bucket into mechanism.
 - compacting unwrapped messy food waste. This will help keep the power ram clean.
- Compacting extreme uneven loads may cause the trash bucket to shift forward which may cause the door to open and interrupt the compaction cycle. Gently push and hold door closed to activate the ram until it returns to the up position. Open the trash bucket and reposition any objects that may be causing the uneven load. Close the door and re-activate the compaction cycle by pressing the start button.
- There are certain types of trash that create exceptionally strong odors such as raw meat, fish, grapefruit rinds, personal hygiene items, and disposable diapers. You may not wish to put such items into your compactor.
- If the compactor will not be used for an extended period of time, such as during vacation, remove the bag to prevent a build-up of undesirable odor.



CAUTION: DO NOT COMPACT AEROSOL CANS OR ANY OTHER CONTAINERS STILL HOLDING OR WHICH HELD TOXIC CHEMICALS, INSECTICIDES, OR COMBUSTIBLE CONTENTS. FUMES MAY BE RELEASED THAT ARE HAZARDOUS TO HEALTH OR MAY RESULT IN FIRE OR EXPLOSION.



Do not put paint, oily rags, lighter fluid cans, paint thinner cans, etc., in your compactor. Doing so could result in spontaneous combustion causing a fire and/or explosion.



NEVER PUSH TRASH INTO THE BUCKET WITH HANDS OR FEET. Trash might contain broken glass, sharp pieces of metal, etc., which could cause injury.

10. BAG REMOVAL

1. Slide out trash bucket.
2. Release bucket latches and lower front of bucket.
3. Unbutton bag from bucket and close by twisting bag top. Fasten with twist-tie provided.
4. Lift and slide bag from bucket.

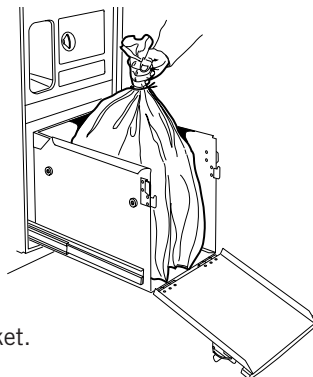

11. CLEANING

Your compactor has been designed with easy access for cleaning when required.

The interior and exterior of the cabinet are finished with a durable baked-on enamel finish.

Do not use harsh or gritty cleanser or scouring pads which may mar the finish of the compactor. Use a mild detergent solution on these surfaces.



CAUTION: Glass fragments and other sharp trash pieces may be on or around the surfaces to be cleaned. Carefully remove these objects before wiping down any surfaces.

REMOVE TRASH BUCKET

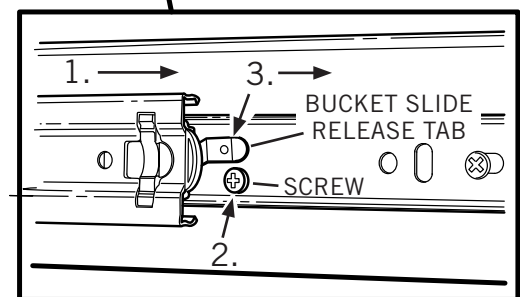
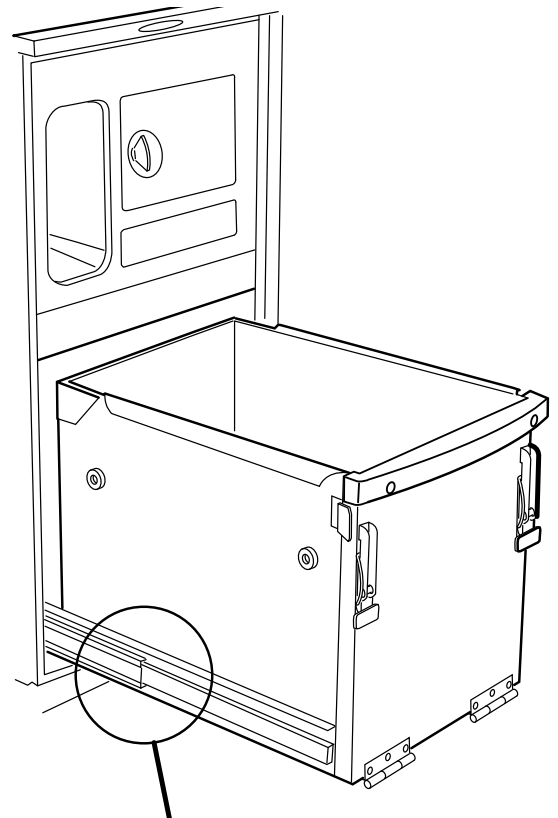

AND CLEAN INTERIOR

11. CLEANING (continued)

1. Pull out trash bucket until it stops.
2. Remove (1) **screw** from each of the bucket slides.
3. Press down on left and right **bucket slide release tabs** while pulling the bucket out of the unit.
4. Vacuum and clean cabinet base, track channels, and bucket, particularly in corners.
5. Wash the cabinet interior with a mild detergent solution.
6. When finished cleaning the cabinet, install the trash

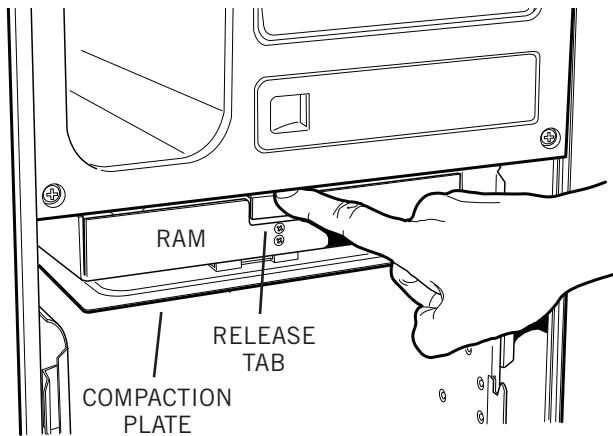

bucket by reversing steps 2 and 3.

CLEAN COMPACTION PLATE

1. The **ram** is equipped with a **compaction plate** that is coated with Microban® antimicrobial protection and can be removed for easy cleaning.
2. Make sure the trash bucket is empty and without a bag.
3. Push the trash bucket into the cabinet. Unlatch and lower the bucket front.
4. Press the compaction plate **release tab** on the front of the ram to disengage the plate. The plate can be removed by pulling down and away from the ram.
5. Once removed the compactor plate can be washed in a mild detergent solution or placed in a dishwasher. Cleaning will not affect the Microban® coating.
6. Re-install the compactor plate by inserting the tab (on the rear of the plate) into the slot (at in the rear of the ram). Press up on the front of the plate until it securely latches in place.

Microban® is a registered trademark of the Microban Products Company.

CLEAN RAM

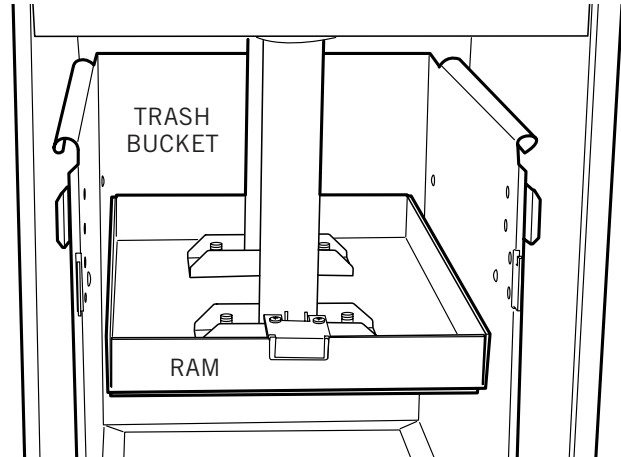

1. Make sure the **trash bucket** is empty and pushed into the cabinet.
2. Turn the Key Lock Switch to “ON” position.



3. Select the “Hold” compact mode.



4. Close the door.
5. Press the “Start” button.



The **ram** will travel downward into the trash bucket and stop at the bottom of its stroke.



CAUTION: Glass fragments and other sharp trash pieces may be on or around the surfaces to be cleaned. Carefully remove these objects before wiping down any surfaces.

6. Open the door. Unlatch and lower the bucket front. Vacuum top of ram and clean with a mild detergent solution.
7. When finished cleaning:
Raise and re-latch bucket front, close door, and press “Start” button. The ram will return to the top of its stroke and automatically shut itself off. Open door, slide bucket out, install bag, and select compact mode. Compactor is now ready to receive trash.

12. TROUBLESHOOTING

Before you call for service, check these handy hints which may save you the cost of a service call:

1. Is electric cord plugged in securely?
2. Has a house fuse blown or a circuit breaker tripped?
3. Is the door pushed firmly shut?
4. Is the key switch in the "ON" position?
5. Did you press the "Start" button long enough to start the compaction cycle?
6. If trash bucket is difficult to close, check to see if any trash has fallen behind the bucket - preventing it from closing completely.
7. The motor has an automatic thermal cutout. If you have compacted repeatedly, this protector may have opened the circuit. Wait a few minutes and the cutout will reset automatically.
8. The trash bucket must be at least 1/2 full of trash before any appreciable amount of compacting will be apparent - as the ram does not travel all the way to the bottom of the bucket. Trash in the bottom 1/3 of the bucket will be crushed during subsequent compacting.
9. On rare occasions, a large can placed near the outer edge of the trash bucket may become wrapped around the edge of the ram. This could interfere with proper ram operation. To correct, simply open the door, unlatch and open the front of the bucket, and remove the can. **BE CAREFUL WHEN HANDLING SHARP OBJECTS!**
10. In the unlikely event that the interlock actuator (on the inside of the door) breaks off, the compactor will not operate. **DO NOT ATTEMPT TO OPERATE COMPACTOR IN ANY OTHER MANNER.** A replacement actuator can be ordered from your Broan Distributor.
11. To obtain service, provide the unit model number, serial number and nature of any defect in the product or part. The model number, serial number and all other data is shown on the model plate, which is located on the inside wall of cabinet. When requesting warranty service, evidence of the original purchase date must be presented. To obtain the name of the warranty service center serving your location, contact the dealer who sold you your compactor or Broan-NuTone LLC.

13. WARRANTY

BROAN-NUTONE ONE YEAR LIMITED WARRANTY

Broan-NuTone warrants to the original consumer purchaser of its products that such products will be free from defects in materials or workmanship for a period of one year from the date of original purchase. **THERE ARE NO OTHER WARRANTIES, EXPRESS OR IMPLIED, INCLUDING, BUT NOT LIMITED TO, IMPLIED WARRANTIES OF MERCHANTABILITY OR FITNESS FOR A PARTICULAR PURPOSE.**

During this one-year period, Broan-NuTone will, at its option, repair or replace, without charge, any product or part which is found to be defective under normal use and service.

THIS WARRANTY DOES NOT EXTEND TO FLUORESCENT LAMP STARTERS AND TUBES. This warranty does not cover (a) normal maintenance and service or (b) any products or parts which have been subject to misuse, negligence, accident, improper maintenance or repair (other than by Broan-NuTone), faulty installation or installation contrary to recommended installation instructions.

The duration of any implied warranty is limited to the one-year period as specified for the express warranty. Some states do not allow limitation on how long an implied warranty lasts, so the above limitation may not apply to you.

BROAN-NUTONE'S OBLIGATION TO REPAIR OR REPLACE, AT BROAN-NUTONE'S OPTION, SHALL BE THE PURCHASER'S SOLE AND EXCLUSIVE REMEDY UNDER THIS WARRANTY. BROAN-NUTONE SHALL NOT BE LIABLE FOR INCIDENTAL, CONSEQUENTIAL OR SPECIAL DAMAGES ARISING OUT OF OR IN CONNECTION WITH PRODUCT USE OR PERFORMANCE. Some states do not allow the exclusion or limitation of incidental or consequential damages, so the above limitation or exclusion may not apply to you. This warranty gives you specific legal rights, and you may also have other rights, which vary from state to state. This warranty supersedes all prior warranties.

To qualify for warranty service, you must (a) notify Broan-NuTone at the address or telephone number below, (b) give the model number and part identification and (c) describe the nature of any defect in the product or part. At the time of requesting warranty service, you must present evidence of the original purchase date.

Broan-NuTone LLC Hartford, Wisconsin
www.broan.com 800-558-1711

Broan-NuTone Canada Mississauga, Ontario
www.broan.ca 877-896-1119