

## Instalacion de empotrado

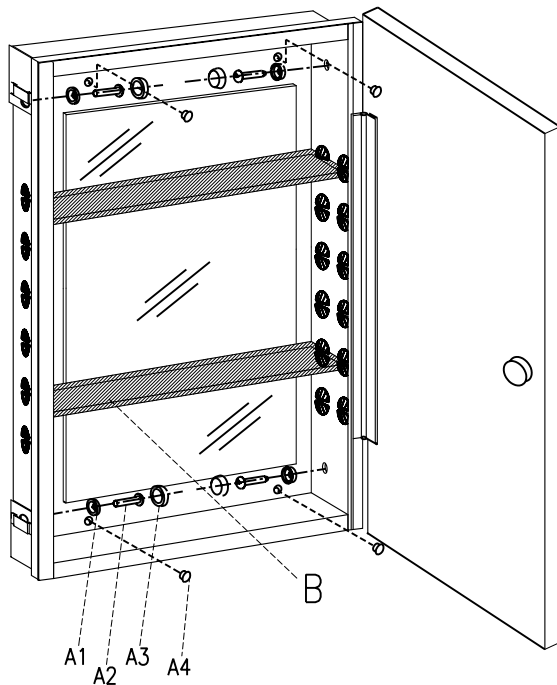

## Instalacion de pared

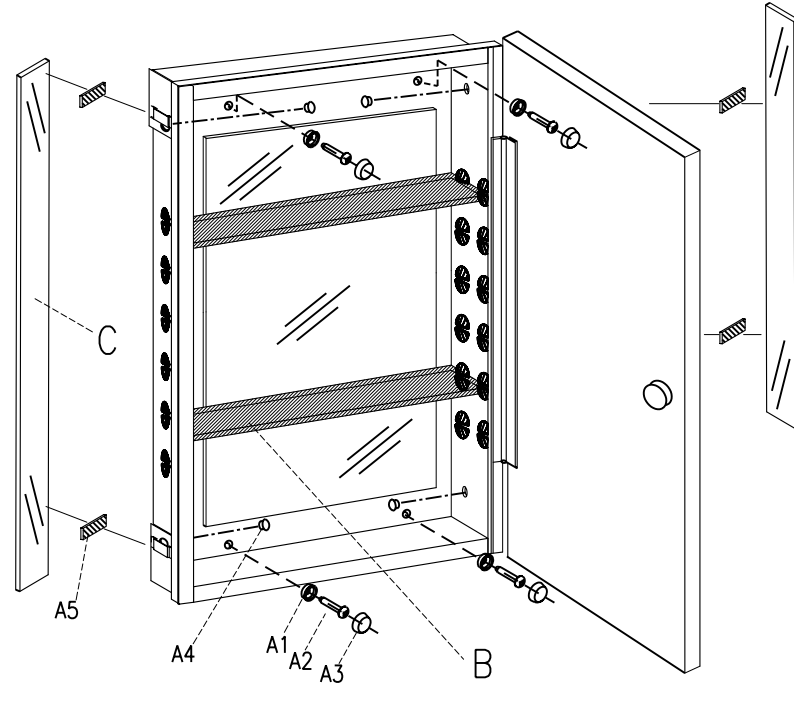

### PIEZAS DE SERVICIO

Pida los piezas de reemplazo por "NUMERO DE PIEZA"

Item No	Descripcion	Qty	Numero de Pieza
A	*Bolsa de Accesorios	1	J2630301
B	Estante de vidrio	1	J3113840
C	Side Mirror (Surface Mount only)	1	J3329302

\*Bolsa de accesorios incluye (4 de c/u):

- A1 (Base del tornillo, transparente)
- A2 (Tornillo, 6x1-1/4)
- A3 (Cubierta del tornillo, negro)
- A4 (Tapones, negro)
- A5 (Tira de cinta)

### CUIDADO DEL ESPEJO

- Utilice solamente agua tibia y un trapo limpio, suave y sin pelusa.
- No utilice limpiadores con solucion a base de amoniac, vinagre o cloro.
- No utilice limpiadores en polvo o fibras de acero.
- Nunca rocíe el limpiador directamente en el espejo, especialmente en los bordes y la cubierta en la parte posterior. Aplique el limpiador al trapo y limpie. Seque a fondo.
- Mantenga el espejo seco. Un baño bien ventilado es importante.

### UN AÑO DE GARANTIA LIMITADA DE BROAN-NUTONE

Broan-NuTone le garantiza al consumidor comprador original de sus productos, que tales productos estaran libres de defectos en materiales o mano de obra por un periodo de un año a partir de la fecha de compra original. NO HAY OTRAS GARANTIAS EXPLICITAS O IMPLICITAS, INCLUYENDO, PERO NO LIMITADAS A GARANTIAS IMPLICITAS DE COMERCIALIZACION O APTITUD PARA UN PROPOSITO EN PARTICULAR. Durante este periodo de un año, Broan-NuTone reparara o cambiara, a su opcion cualquier producto o pieza que se encuentre defectuosa bajo uso y servicio normal. ESTA GARANTIA NO SE EXTIENDE A ARRANCADORES DE LAMPARAS FLUORESCENTES Y TUBOS. Esta garantia no cubre (a) mantenimiento y servicio normal o (b) cualquier producto o pieza que hayan sido sometidos a uso equivocado, negligencia, accidente, mantenimiento o reparacion indebida (excepto por Broan-NuTone), instalacion defectuosa o instalacion contraria a las instrucciones de instalacion. La duracion de cualquier garantia implicita se limita a un periodo de un año de acuerdo a como se especifica en la garantia explicita. Algunos estados no permiten limitacion a la duracion de una garantia implicita, por lo que esta limitacion tal vez no se aplica a su caso. LA OBLIGACION DE BROAN-NUTONE DE REPARAR O CAMBIAR, A OPCION DE BROAN-NUTONE, SERA EL UNICO Y EXCLUSIVO REMEDIO AL COMPRADOR BAJO ESTA GARANTIA. BROAN-NUTONE NO SERA RESPONSABLE POR DANOS INCIDENTALES, CONSECUENTES, O ESPECIALES QUE SURJAN DE O EN RELACION A EL USO O DESEMPEÑO DEL PRODUCTO. Algunos estados no permiten la exclusion o limitacion de danos incidentales o consecuentes, por lo que esta limitacion o exclusion tal vez no se aplica en su caso. Esta garantia le da derechos legales especificos, y tal vez puede tener otros derechos que varian de estado a estado. Esta garantia reemplaza todas las garantias anteriores. Para calificar para servicio bajo esta garantia, usted debe (a) notificar a Broan-NuTone a la direccion que aparece abajo o al telefono 1-800-637-1453, (b) dar el numero de modelo y la identificacion de pieza y (c) describir el defecto. Debera proveer evidencia de la fecha de la compra original a la hora de solicitar algun servicio en base a su garantia.

Broan-NuTone LLC, 926 West State Street, Hartford, WI 53027 (1-800-637-1453)

# BROAN®

MODELS: 56SS184CVB, 56SS184CSN

This Medicine Cabinet was designed to be either Recessed or Surface Mounted. Please follow installation instructions according to that style.

### INSTALLATION INSTRUCTIONS

WALL OPENING			OVERALL SIZE		
W	H	D	W	H	D
14	18	4	15	19	5

### Recessed Mount Installation:

1. Carefully remove all packing material. Place hardware packages, and shelves aside until needed.
- 2a. **Replacing an existing recessed bath cabinet.**  
Remove existing cabinet from the wall. Measure the rough wall opening. The opening must be the size shown in (Table 1) above. If the opening is the proper size, the cabinet will easily fit between existing studs. Then, continue to Step 3. If the opening is too large, new framing may be required. If the opening is too small, the existing wall cut out may need to be enlarged. The services of a professional carpenter are highly recommended for any wall modifications.  
NOTE: The rough wall opening must be free of all obstructions. If plumbing or electrical lines interfere with the wall opening, they must be relocated. This must be done in accordance with local and national codes preferably by a plumber and/or electrician.
- 2b. **Installing a recessed bath cabinet into new construction.**  
Determine desired location of cabinet on wall. Mark wall to show wall opening size (see Table 1). Cut wall opening, being careful not to damage the surrounding wall surface. Insert framing to support all plaster board edges. NOTE: The services of a professional carpenter are highly recommended for any wall modifications. Wall studs, plumbing or electrical lines that interfere must be removed or relocated. This must be done in accordance with local and national codes preferably by a plumber and/or electrician.
3. Prepare the mounting screws by placing the screws into the clear plastic bases. (Fig. 2)
4. Insert cabinet into wall opening. Ensure the cabinet is plumb and level. If necessary use a carpenter's level and shim corners of cabinet. Secure to the wall studs through the four (4) mounting holes inside cabinet, using the screws that have been placed into the plastic bases. (Fig. 4) Note: For ease of installation, an additional person is recommended  
**\*\*IMPORTANT\*\* Do not over tighten the mounting screws as the body side wall may bend and prevent proper shelf installation. Only tighten the mounting screws until they are flush with the body.**
5. Snap the screw covers over the screw bases. (Fig. 3)
6. Remove hole plugs from hardware bag and place into the body. (Fig. 4)
7. Carefully slide shelves into the cabinet body.
8. Dispose of side mirrors and extra installation hardware.

### Surface Mount Installation:

1. Carefully remove all packing material. Place hardware packages, and shelves aside until needed.
2. Determine location of cabinet on wall and mark drilling location through mounting holes shown in Figure 1. Make sure cabinet is level and should be checked and adjusted by using a carpenter's level. Note: The standard placement of a mirrored bath cabinet is 64" from the floor to the center of the mirror area.
3. Gently, place cabinet aside and drill mounting holes, using a drill bit .28"-.30" (9/32" or K,L,M) into drywall. Note: Irregularities in wall may cause distortion of the surface mounted cabinet body and may require "shims" to be placed between cabinet and wall. Place the 5/16" wall anchors (provided) into the mounting holes until they are flush with the wall.
4. Prepare the mounting screws by placing the screws into the clear plastic bases (Fig. 2).
5. Place cabinet over one of the upper mounting holes and screw through mounting hole as shown in the Figure 1. Align the cabinet to reveal the second drilling mark through the mounting hole. Re-check the cabinet's alignment to ensure a leveled mount. Once level, then place remaining screws into mounting holes and tighten screws securely.
6. Snap the screw covers over the screw bases. (Fig. 3)
7. Installing the side mirrors. Carefully apply tape strips to both stand-offs located on each side of the cabinet by removing protective coating on both sides. (Fig. 5) Once applied, carefully position the side mirror to the Stand-off. (Fig. 6) Please reference for positioning steps before applying the side mirror (Fig. 7). Carefully position the Side Mirror BEFORE pressing the mirror back onto the tape adhesive.

