



# DISHWASHER

# SERVICE MANUAL

## NOTE

BEFORE SERVICING THE UNIT, PLEASE READ THIS MANUAL CAREFULLY FOR SAFETY AND CORRECT SERVICES.

MODEL : LDF7932(WW,BB,ST)

# CONTENTS

---

1. CAUTION.....	4
2. SPECIFICATIONS .....	5
3. WIRING DIAGRAM.....	6
4. FEATURES & TECHNICAL EXPLANATION .....	7
5. PARTS NAME .....	11
6. PROGRAM CHART .....	12
7. HOW TO DISASSEMBLE .....	13
8. TROUBLE SHOOTING METHODS.....	22
A. TROUBLE SHOOTING ACCORDING TO DISPLAYED ERROR MESSAGE .....	22
B. STEAM GENERATOR ERROR MESSAGE.....	24
C. TROUBLE DIAGNOSES AND REPAIR BY SYMPTOM .....	25
9. INSTALLATION INSTRUCTION .....	29
10. EXPLODED VIEW .....	36

# CAUTION !

- DISCONNECT POWER CORD BEFORE SERVICING
- RECONNECT ALL GROUNDING DEVICES

## IMPORTANT SAFETY NOTICE !

This service information is intended for individuals possessing adequate backgrounds of electrical, electronic and mechanical experience.

Any attempt to repair this appliance may result in personal injury and property damage.

The manufacturer or seller can not be responsible for the interpretation of this information, nor can it assume any liability in connection with its use.

## 2. SPECIFICATION

---

ITEM	SPECIFICATION
Rated Voltage / Frequency	AC 120V/60Hz
Installation	Built-In
Place Settings	16
Product Dimension(in)	23 3/4" x 24 5/8" x 33 1/2"
Product Weight(lbs)	97lbs
Door Color	White, Black, Stainless
Tub Material	Stainless Steel
Control	Electronic
Rated Power(Watt)	1,350
Heater Power(Watt)	1,200
Programs	6
Upper Rack Position	Adjustable
Lower Rack	50% Fold down
Water Consumption ( ℓ )	10-26 (Normal)
Power Consumption(kWh/year)	285-310
Operating Time (min)	101-135 (Normal)
Fan Dry System	Yes
Delay Start Function	Yes
Auto-Off Power Switch	Yes
Process Monitor	Yes
Wash Level	5
Racks	Nylon Coating
Operating Water Pressure (Bar)	20-120 (140-830kPa)

# 3. WIRING DIAGRAM

## 7932 series

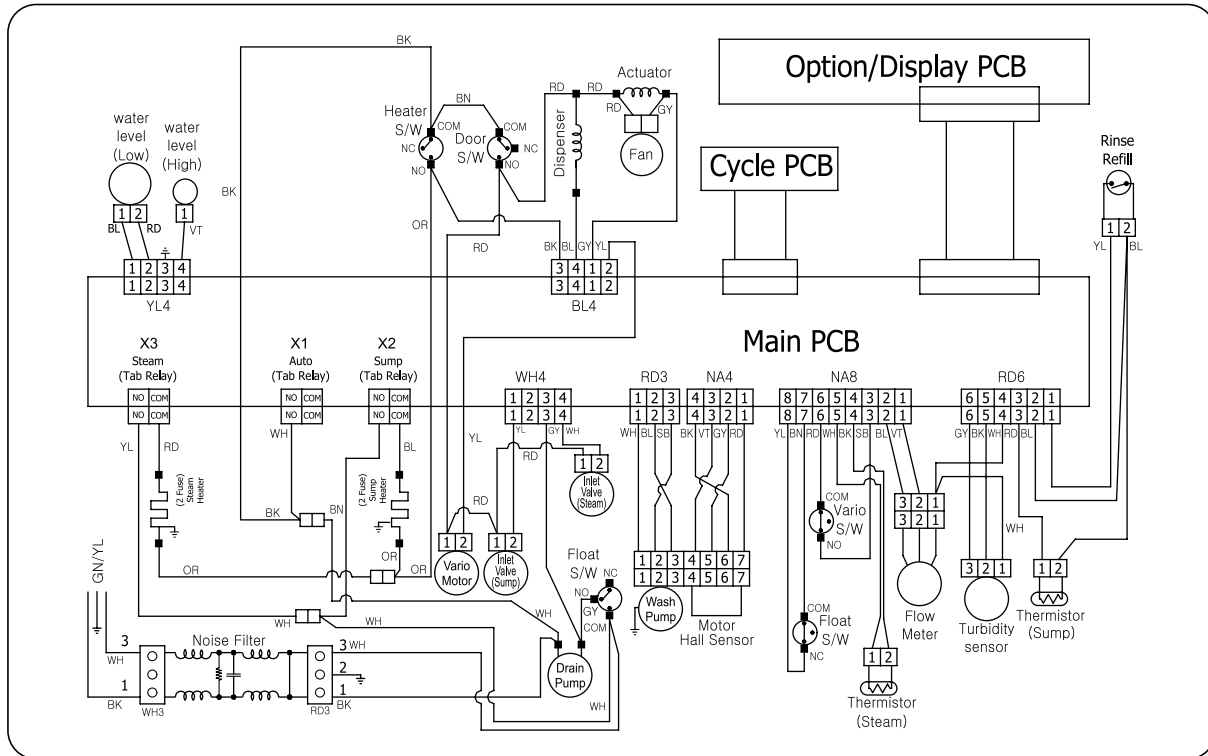

# 4. FEATURES & TECHNICAL EXPLANATION

## 4-1. Product Features

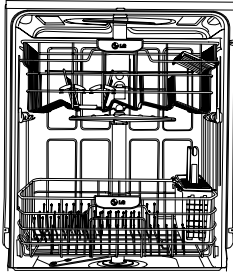

### ■ Ultra Big Capacity

If you raise the Upper Rack, you can load large dishes in the Lower Rack. (Max. 14 in.)

The tall tub provides large dishes loading as well as large capacity.

LG dishwashers let you load oversized items in the Lower and Upper Rack.

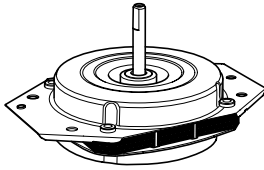

### ■ Slim Direct Motor™

Newly introduced Slim Direct Inverter motor is inverter-controlled. Speed is controlled based on program selection. It also offers high energy efficiency to minimize energy loss.

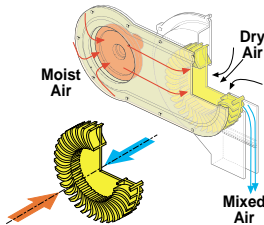

### ■ Hybrid Drying System

This is one of the best performance solutions for drying dishes because it minimizes venting humid air to the outside of the dishwasher. In addition, this system ensures better drying results compared to the condensing drying system.

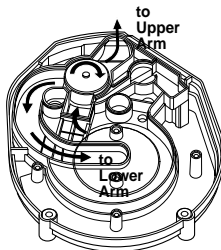

### ■ Vario Spray System

Because of alternating water spray between the Upper and Lower Rack, the water pressure allows superior performance and reduced consumption of water and electricity.

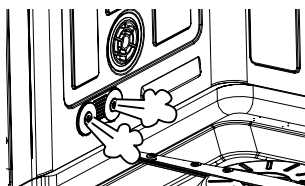

### ■ Steam Washing and Steam Delicate™

Adding STEAM to the wash cycles enhances wash performance with very little additional water or energy consumption. The SteamDelicate™ cycle can be used for cleaning delicate item such as china or stem ware.

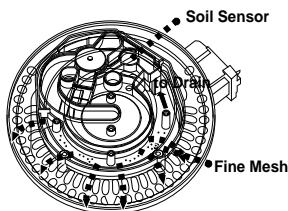

### ■ Self Cleaning Filter

For best wash results, the self-cleaning filter system continuously cleans the water as it circulates. Your LG dishwasher has a self-cleaning filter that grinds food into small particles before it goes down the drain.

## 4-2. Display Panel LDF 7932 Series

■ Control panel may vary on some models.

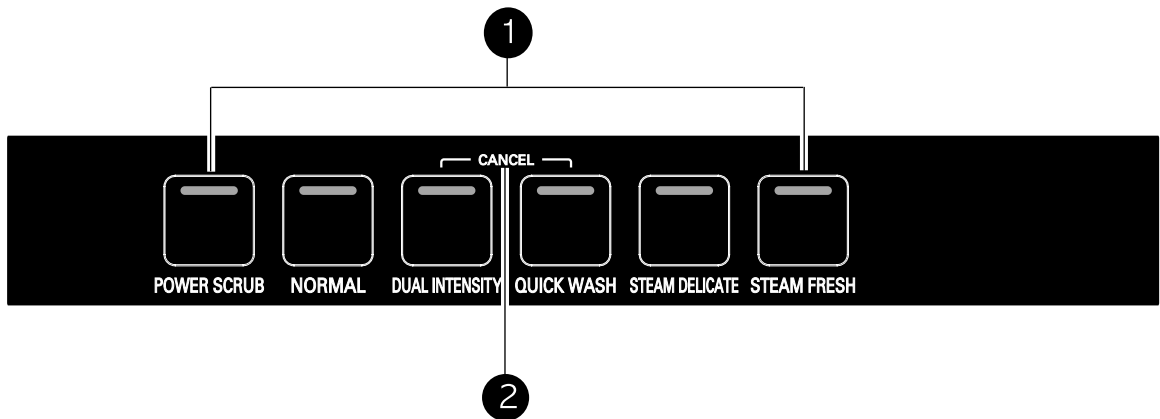

### 1 CYCLES

Press the cycle that corresponds to your desired wash cycle.

#### **POWER SCRUB**

This cycle is for very heavily soiled dishes.

#### **NORMAL**

This cycle is for normally soiled, everyday loads.

#### **DUAL INTENSITY**

This cycle washes the upper and lower racks at different spray intensities. The lower rack is washed with a strong spray for hard to clean items, while the upper rack is washed with a soft spray for more delicate items. This provides optimum cleaning performance for mixed loads, including fine china and stemware. Both the strong and soft spray lights will stay on to indicate the dishwasher is in the Dual Intensity cycle.

#### **QUICK WASH**

This is a shortened cycle that is perfect for recently used or lightly soiled loads.

#### **STEAM DELICATE**

This cycle adds the gentle power of steam to boost the cleaning power of the delicate cycle. The cycle is perfect for effectively cleaning delicate items like fine china or stemware.

#### **STEAM FRESH**

This cycle can be used to freshen up dishes that may have been stored or not used for a long time.

#### **CHIME ON/OFF**

To enable or disable the chime, press and hold the Quick Wash and Rinse buttons for 2 seconds.

#### **RINSE ONLY**

This cycle is a quick rinse for dishes that will not be washed immediately. No detergent should be used. To select the Rinse Only cycle, press the Power button; then press the Rinse button once without pressing any other cycle buttons.

NOTE: If a main cycle has been selected, the Rinse Only cycle will not be available without first shutting the power off.

### 2 CANCEL

To cancel a running cycle, open the door and then press and hold the Dual Intensity and Quick Wash buttons together for 3 seconds. The drain pump will be activated and the cycle will be cancelled.

### 3 CYCLE OPTIONS AND DISPLAY

Press the desired cycle option buttons to select and set any of the dishwasher's options described below. The display will show the selected cycle times and cycle options.

#### **SPRAY (INTENSITY)**

Repeated pressing of the Spray button will select the desired spray. The strong, medium, or soft light will show in the top left portion of the display.



#### **RINSE**

Repeated pressing of the Rinse button will select the desired Rinse option. The Sanitary, Extra Rinse, or Sanitary and Extra Rinse lights will show in the bottom left portion of the display.



- If you select the Sanitary feature, the Sanitary light will blink until the water is heated to the sanitary temperature level\*. Once the sanitary temperature level is reached, the light will stay on to indicate that the sanitary temperature has been reached.  
\*NOTE: This high-temperature rinse sanitizes dishware and glassware in accordance with NSF/ANSI Standard 184 for residential dishwashers. Certified dishwashers are not intended for licensed food establishments.
- When you select Extra Rinse, an additional rinse cycle is added.
- Rinse Only

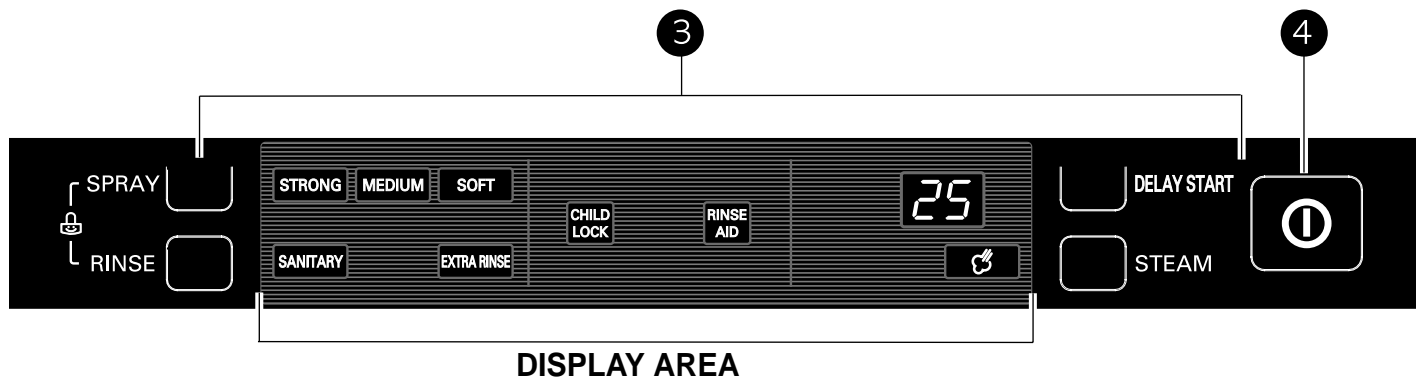

### CHILD LOCK



Lamp will turn on when Child Lock setting is on.

- To lock/unlock the buttons, press SPRAY and RINSE simultaneously for 3 seconds with the door open.
- Lock the control buttons during cycle operation to prevent settings from being changed.

### RINSE AID



Refill with rinse aid when the lamp turns on.

### DIGITAL DISPLAY



The Digital Display on the control panel shows the estimated cycle and option times in a two-digit display.

When the dishwasher is powered up, the display will be blank. When the cycle and options are selected, the display will show the total estimated time to complete those selections. During operation, the display shows the remaining estimated operating time.

#### NOTES:

- The estimated time shown in the display does not include delay times for heating water, etc.
- If total time exceeds 99 minutes, the display shows times in whole hours. (2H, 3H, etc.)
- If Delay Wash is selected,

### DELAY START

- To delay the start of a selected cycle, press the Delay Start button.
- Each time Delay Start is pressed will delay the start of the cycle by one additional hour.
- The delay start time can be set from 1 to 12 hours in one-hour increments.

### STEAM



- Press the Steam button to add steam to a selected cycle.
- The Steam symbol light will stay on when the STEAM option has been selected.
- The symbol light will blink while steam is being injected into the dishwasher.

### 4 POWER

- Pressing the Power button turns on power to the controls.
- After the cycle is complete, the power automatically turns off for safety and economy.
- If there is a power surge, power outage, or disruption of any kind, the power will be automatically turned off for safety, and the cycle will need to be restarted.



## 4-3. TEST MODE LDF 7932 Series

### CHECK PROGRAM

BUTTON	The number of pushing button	Top Display	Load and Checking points		Door open/closed
Spray + Rinse + POWER	1 TIME	3H U0	All LEDs are lighting		Both
Power Scrub	1 TIME	11	All LEDs are lighting		Both
Normal	1 TIME	22	All LEDs are lighting		Both
Dual Wash	1 TIME	33	All LEDs are lighting		Both
Quick Wash	1 TIME	44	All LEDs are lighting		Both
Steam Delicate	1 TIME	55	All LEDs are lighting		Both
Steam Fresh	1 TIME	66	All LEDs are lighting		Both
Spray	1 TIME	77	All LEDs are lighting		Both
Rinse	1 TIME	88	All LEDs are lighting		Both
Steam	1 TIME	99	All LEDs are lighting		Both
Delay start	1 TIME	Steam generator Temp(°C)	Steam generator Thermistor	All LEDs	Both
	2 TIME	H1	Steam generator Heater (for 1.2 sec)	All LEDs	Closed
	3 TIME	33	Drain Pump	All LEDs	Both
	4 TIME	① Frequency	Inlet Valve	All LEDs	Closed
	5 TIME	35	Dispenser	All LEDs	Closed
	6 TIME	36	Sump Heater (for 10 sec)	All LEDs	Closed
	7 TIME	37	Fan Motor	All LEDs	Closed
	8 TIME	38		All LEDs	Closed
	9 TIME	Sump Temp(°C)	Sump Thermistor	All LEDs	Both
	10 TIME	② Soil level	Soil sensor	All LEDs	Both
	11 TIME	3B	Wash Pump	All LEDs	Closed
	12 TIME	Steam generator Water level	③ H170 ↑ / L170 ↑	All LEDs	Both
	13 TIME	3D	Lower Nozzle (Vario)	All LEDs	Closed
	14 TIME	3E	Upper Nozzle (Vario)	All LEDs	Closed
	15 TIME	3F	W/Pump+Vario+ Heater (for 1min)	All LEDs	Closed

① Normal water level : 270 ~ 275

② Pure water : more than 130

③ H: High water level / L: Low water level

※ Steam Demo mode : Steam + Power

# 5. PARTS NAME

## 5-3. LDF 7932 Series

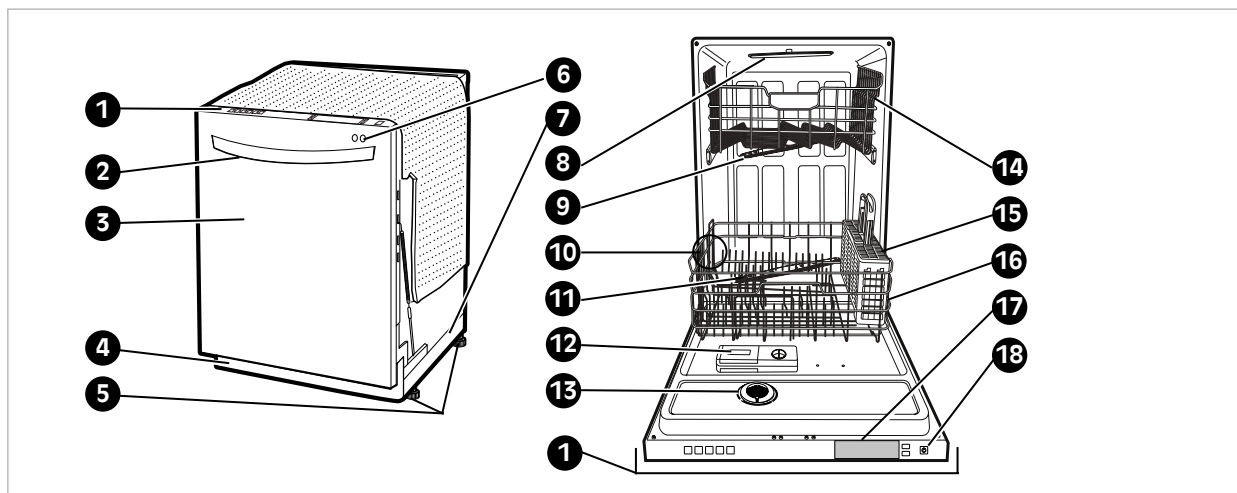

- ❶ CONTROL PANEL
- ❷ DOOR HANDLE
- ❸ FRONT COVER
- ❹ LOWER COVER
- ❺ LEVELING FEET
- ❻ FRONT DISPLAY (Signalight™)
- ❼ BASE
- ❽ TOP SPRAY ARM
- ❾ UPPER SPRAY ARM
- ❿ STEAM NOZZLE

- ⓫ LOWER SPRAY ARM
- ⓬ DETERGENT AND RINSE AID DISPENSER
- ⓭ DRYING VENT COVER
- ⓮ UPPER RACK
- ⓯ SILVERWARE BASKET
- ⓰ LOWER RACK
- ⓱ TOP DISPLAY
- ⓲ POWER BUTTON

### Accessories

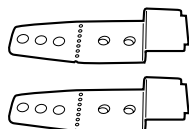

INSTALL BRACKET



WOOD SCREW

※ The appearance and specifications may be varied without notice according to localities.



# 7. HOW TO DISASSEMBLE

## BEFORE DISASSEMBLING THE DISHWASHER ;

- 1) Remove the cord from electric outlet to avoid electric shock.
- 2) Close the Water Tap (faucet).
- 3) Remove all dishes and items in the dishwasher.
- 4) Remove the Lower Rack and the Upper Rack.
- 5) Remove the inlet hose and drain hose connection to avoid the hose damages.
- 6) Prepare some towels to avoid floor wet by the water left in the dishwasher.

## 7-1. FULL DISASSEMBLE

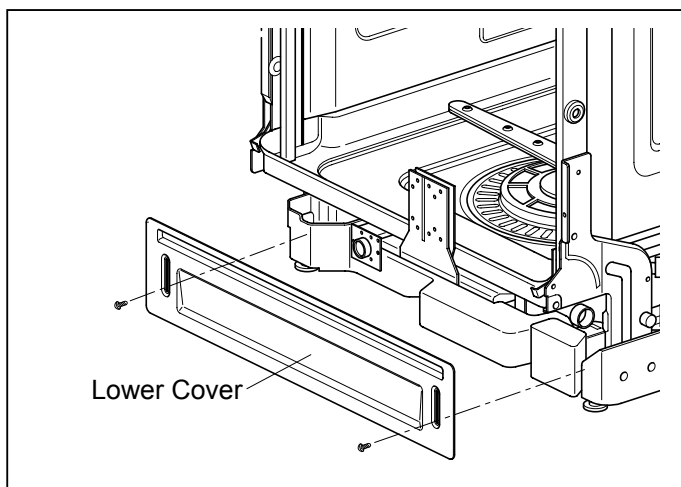

### 1. Lower Cover and Lower Felt

- 1) Remove the front 2 screws.
- 2) Remove the Inlet Hose and Power Supply Cable.

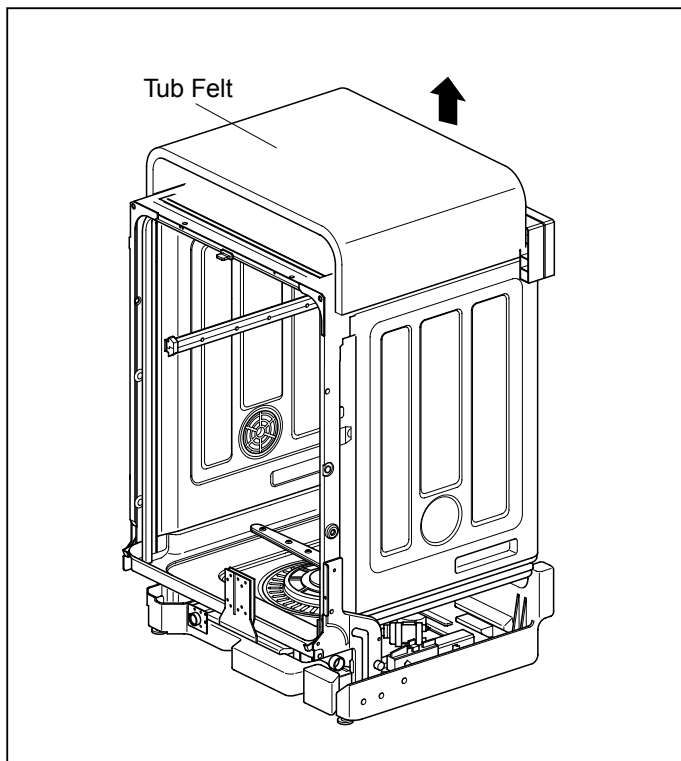

### 2. Tub Felt

- 1) Tub Felt
  - ① Pull the Tub Felt.

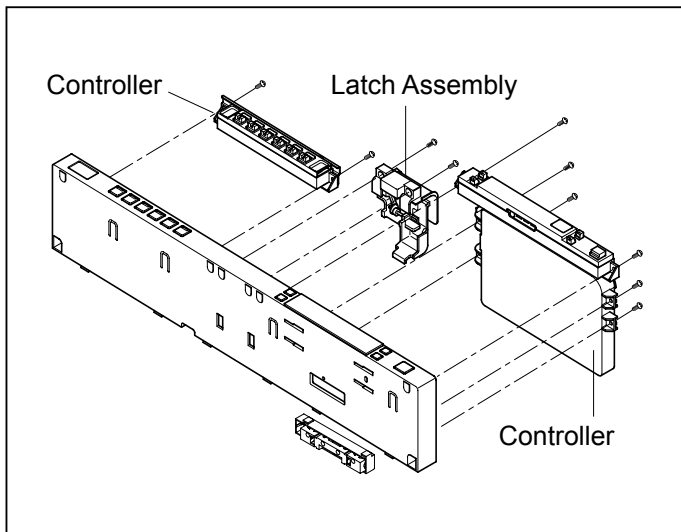
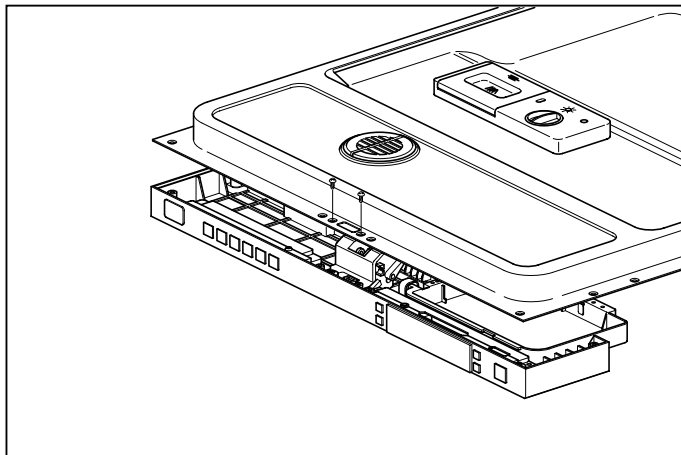
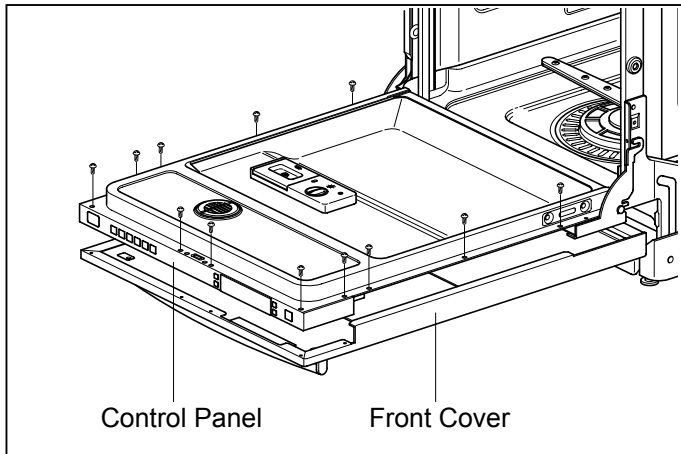

### 3-1. Door Assembly

#### 1) Front Cover

- ① Open the door.
- ② Remove 12 screws(stainless).

#### 2) Control Panel Assembly

- ① Remove 2 screws(Stainless).
- ② Remove the wire connections.

Be sure the wiring should not be changed in reassembling

- ③ Remove the Latch assembly.
- ④ Remove the Front Display.
- ⑤ Remove 8 screws for Controller.

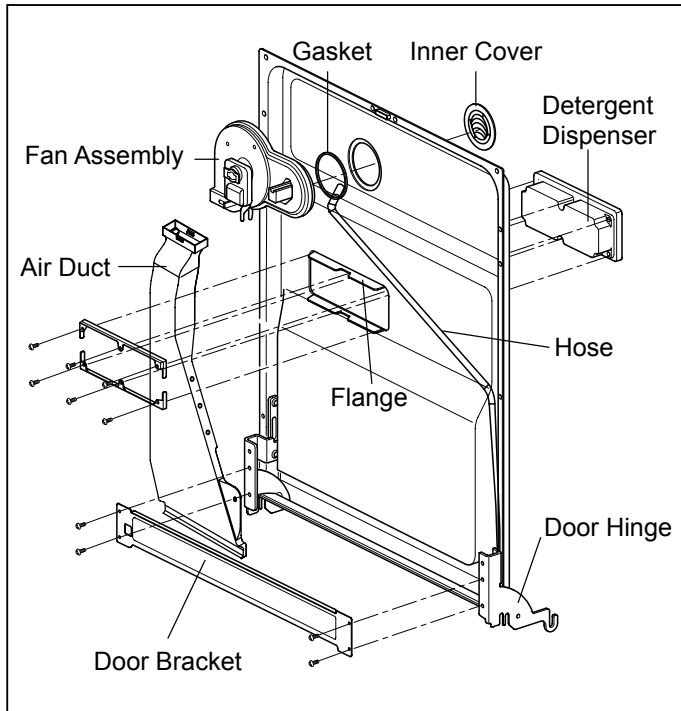

### 3) Fan Assembly

- ① Open the door.
- ② Remove 4 screws and a earth screw for Door Bracket.
- ③ Remove the wire connetions.
- ④ Remove the Air Duct.
- ⑤ Turn the Inner Cover counterclockwise.

### 4) Detergent Dispenser

- ① Close the door
- ② Remove the wire connections.
- ③ Remove 6 screws with brackets.
- ④ Push the Detergent slowly pulling up the the Flange by Standard Screwdriver.

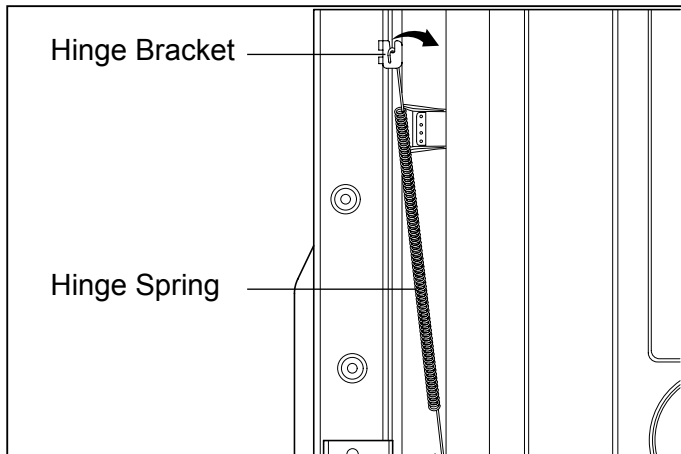

### 5) Door Spring (Right & Left)

- ① Push the Spring upwards and take it off from the Hinge Bracket.

Be careful not to be injured by the sharpedge of Tub.

- ② Take off the Hinge Link from the Hinge.

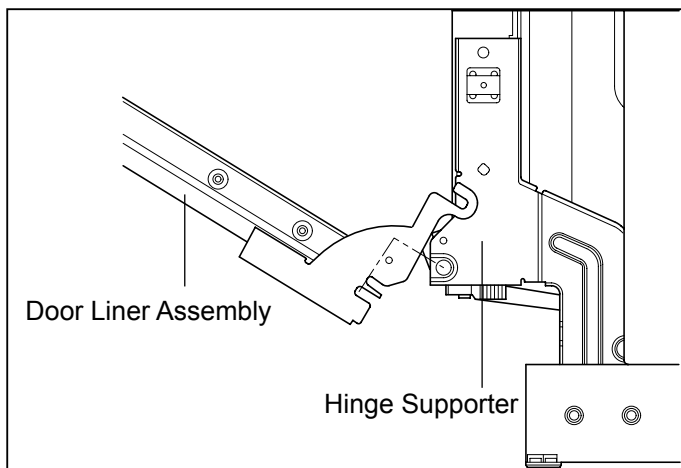

### 6) Door Liner

- ① Open the door.
- ② Pull the Door Liner and take it off from the Hinge Supporter.

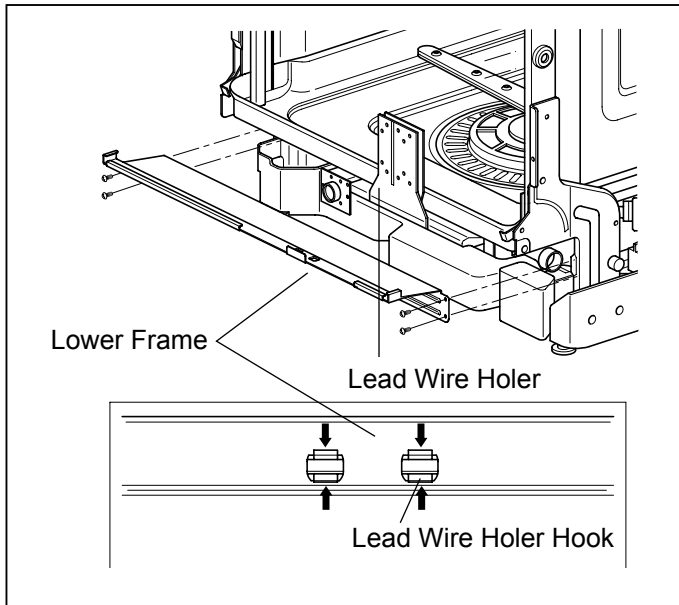

#### 4. Lower Frame

- 1) Press the holder hook as shown in figure.
- 2) Remove 4 screws.

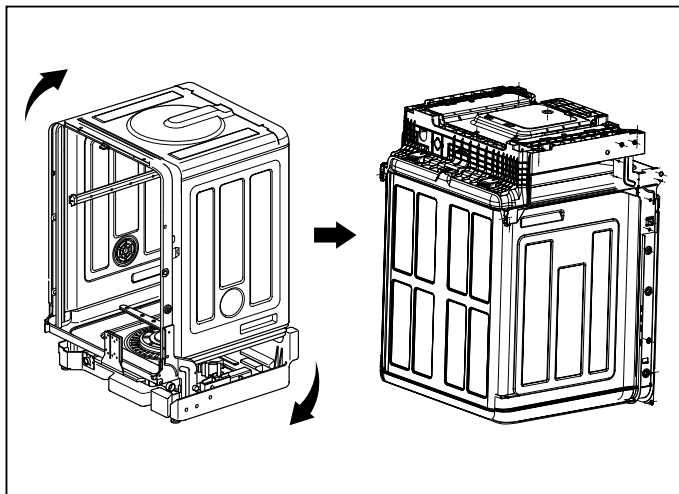

#### 5. Put the Dishwasher upside down.

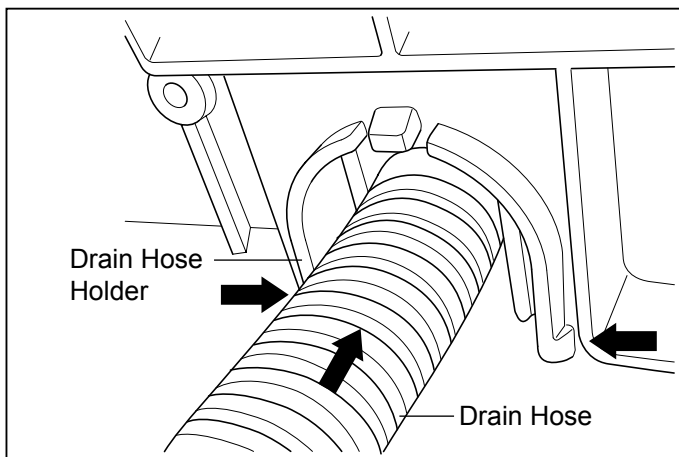

#### 6. Drain Hose Holder

- 1) Press the holder hook as shown in figure.
- 2) Pull the Drain Hose and remove the Drain Hose Holder.

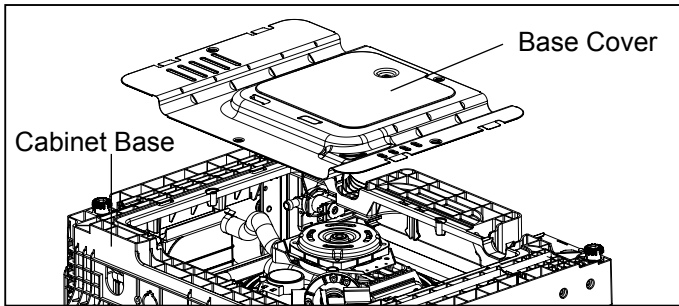

## 7. Base Cover

- 1) Remove 2 screws.
- 2) Pull the Base Cover out.

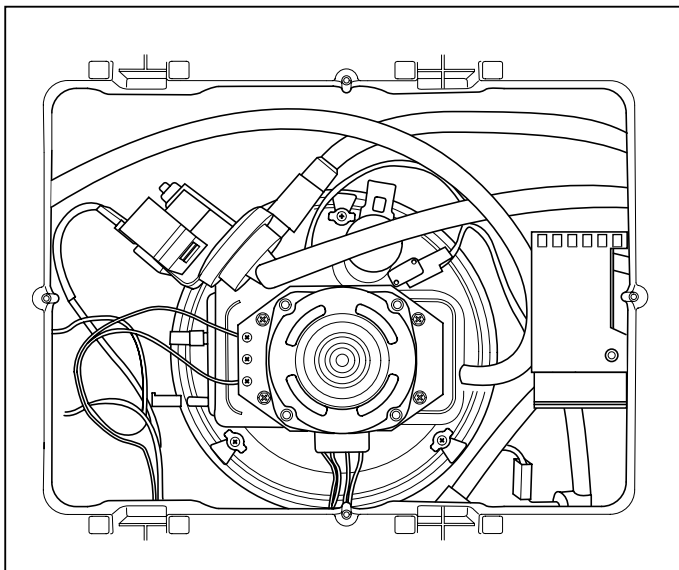

## 8. Harness & Hose Assembly

- 1) Remove the wiring connections.
- 2) Remove the Hose connections from Sump Assembly.

You can see the information of Wiring Diagram at the back of Lower Cover.

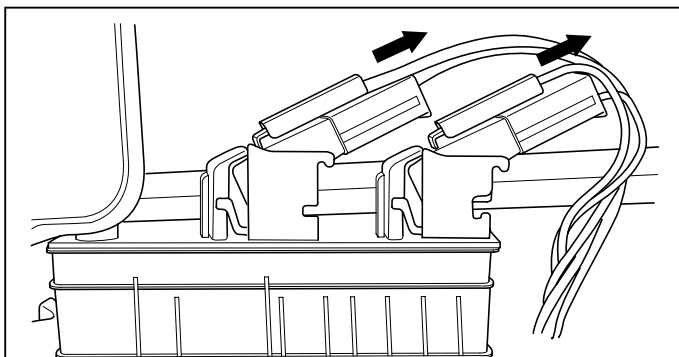
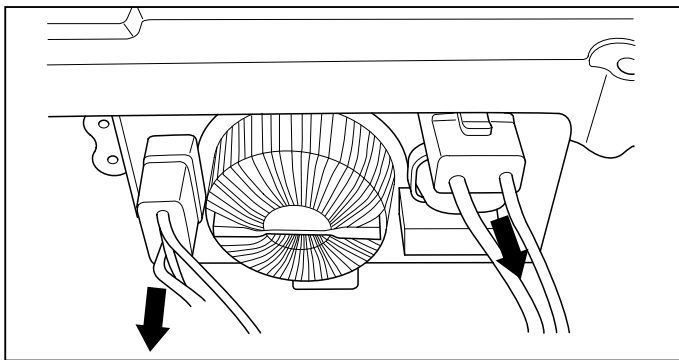



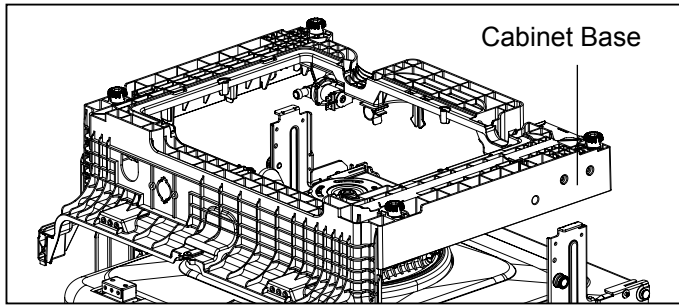

## 9. Cabinet Base

- 1) Remove 8 screws.
- 2) Lift it upward.

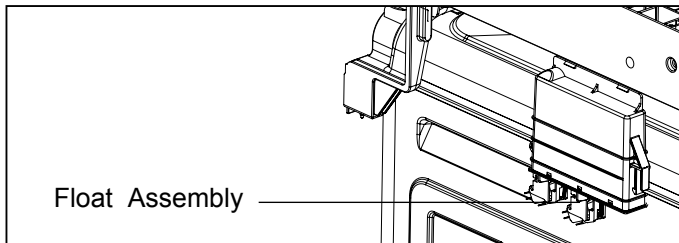

## 10. Float Assembly

- 1) Press the Float hook.
- 2) Pull the Float Assembly

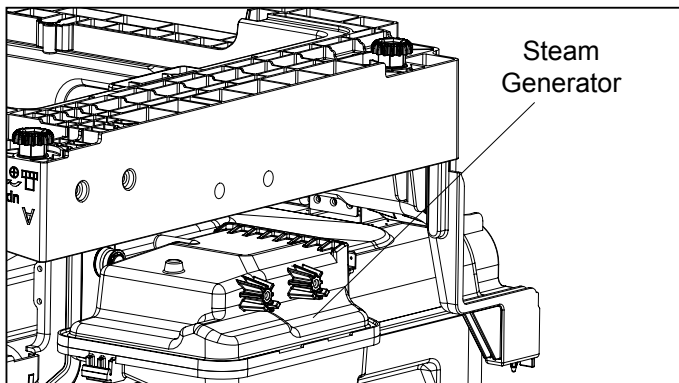

## 11. Steam Generator

- 1) Disconnect the 3 hoses assembly.
- 2) You can disassemble the Steam generator by removing the 2 screws.

### CAUTION

Be cautious in case of the generator is hot temperature.

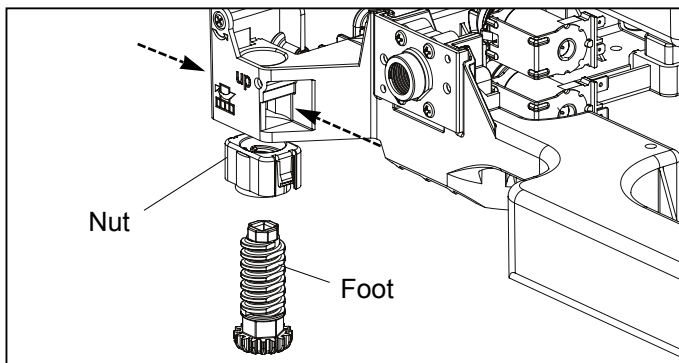
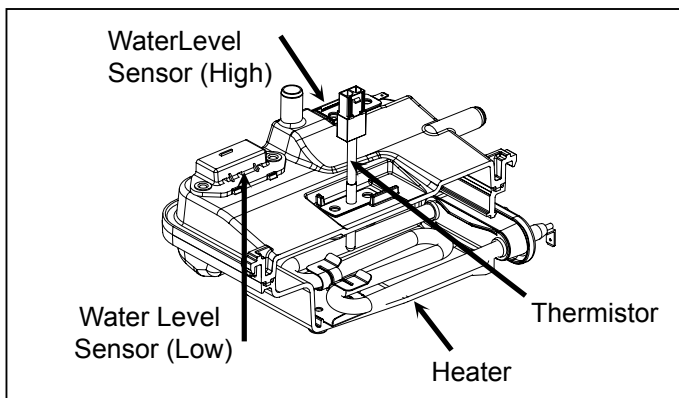

## 12. Foot & Nut

- 1) Pull the Foot twisting
- 2) Pull the Nut pushing the hook.

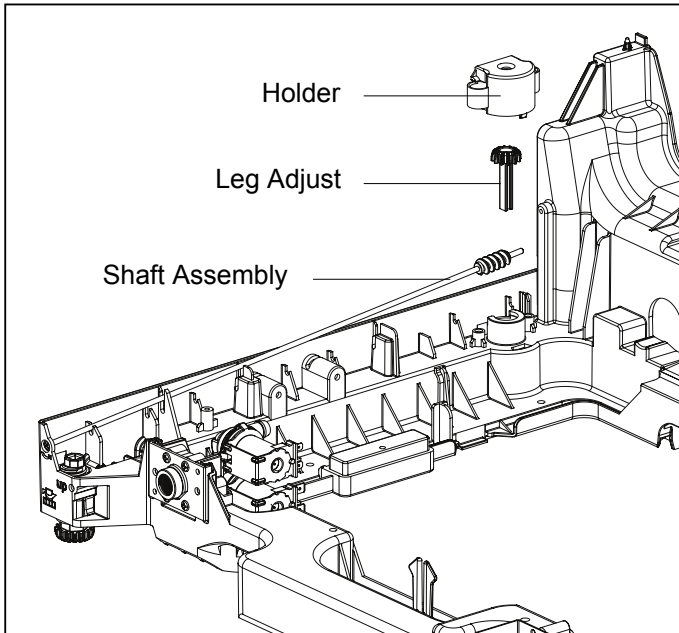

### 13. Rear Leg Adjustment System

- 1) Remove 2 screws.
- 2) Pull the Holder.
- 3) Pull the Leg Adjust.
- 4) Pull the Shaft Assembly.

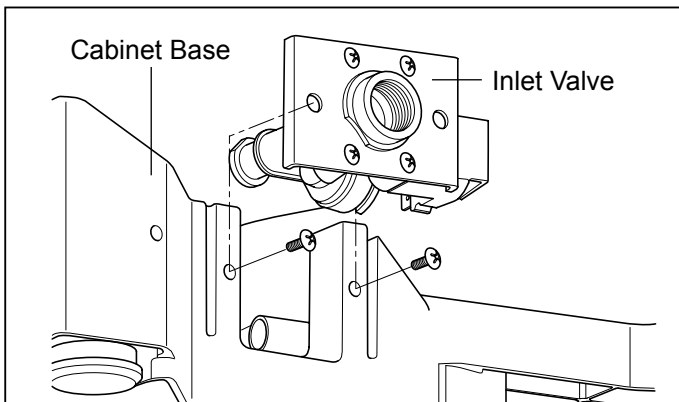

### 14. Inlet Valve

- 1) You can disassemble the Inlet Valve by removing the 2 screws.

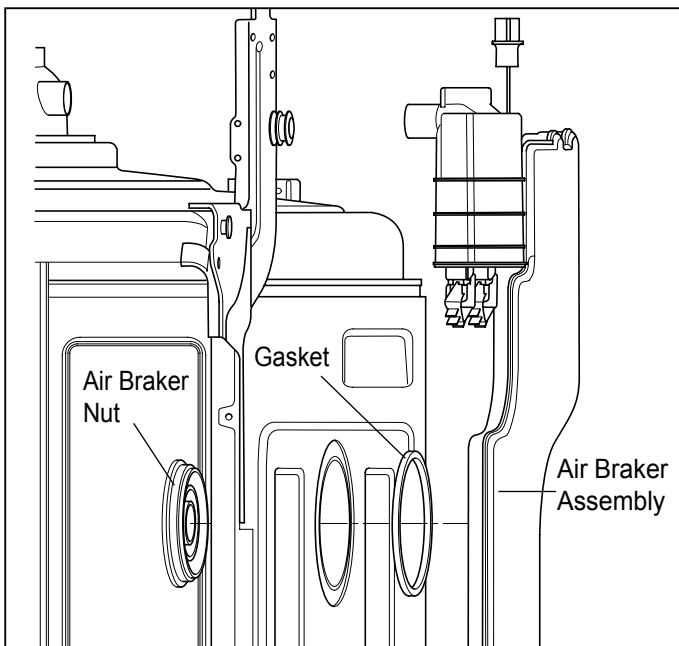

### 15. Air Braker Assembly

- 1) Disconnect the 3 hoses assembly.
- 2) Turn the Air Braker Nut counterclockwise.

Be careful the o-ring should not be lost.

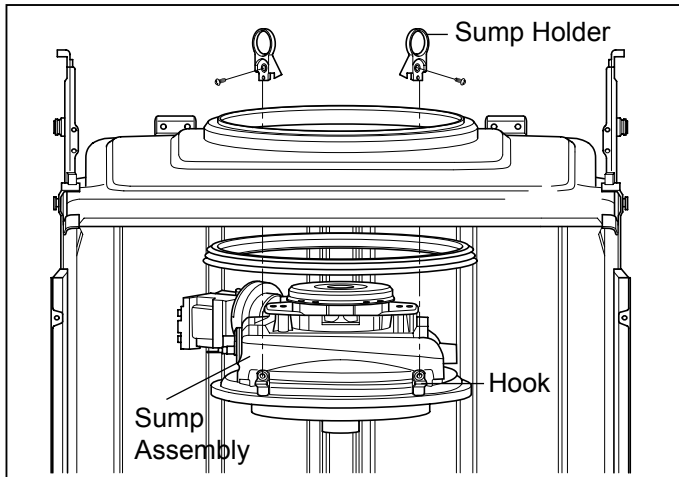

## 16. Sump Assembly

- ① Remove 2 screws.
- ② Remove the Sump Holder and push the Sump Assembly down with pulling aside Hook.

Be careful not to drop the Sump Assembly to the bottom.

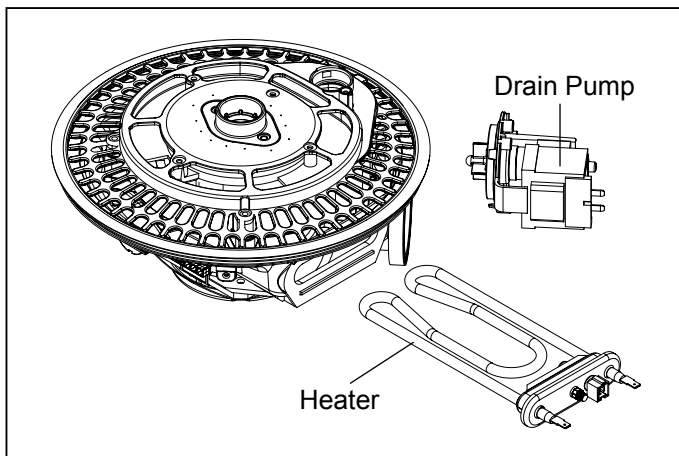

### 1) Heater & Drain Motor

- ① Pull the Heater out of the Sump after releasing the nut.
- ② Remove 3 screws.

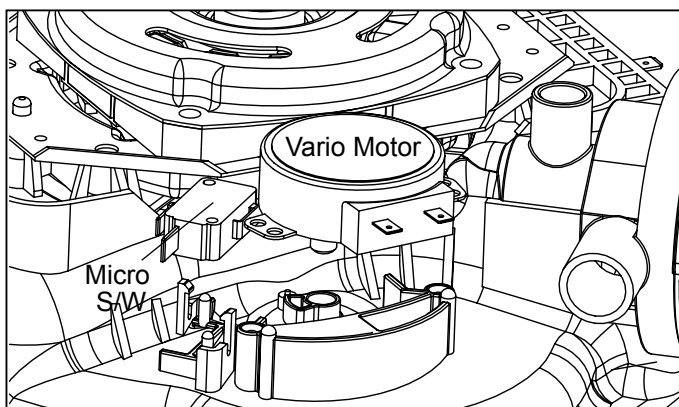

### 2) Vario Motor

- ① Remove 2 screws for Vario Motor.
- ② Pull the Vario Motor and Micro S/W.

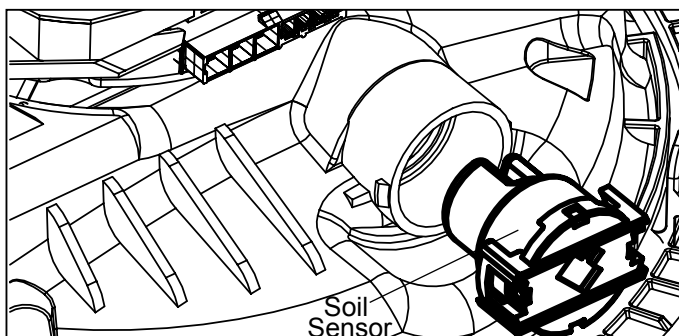

### 3) Soil Sensor

- ① Pull the Soil Sensor.

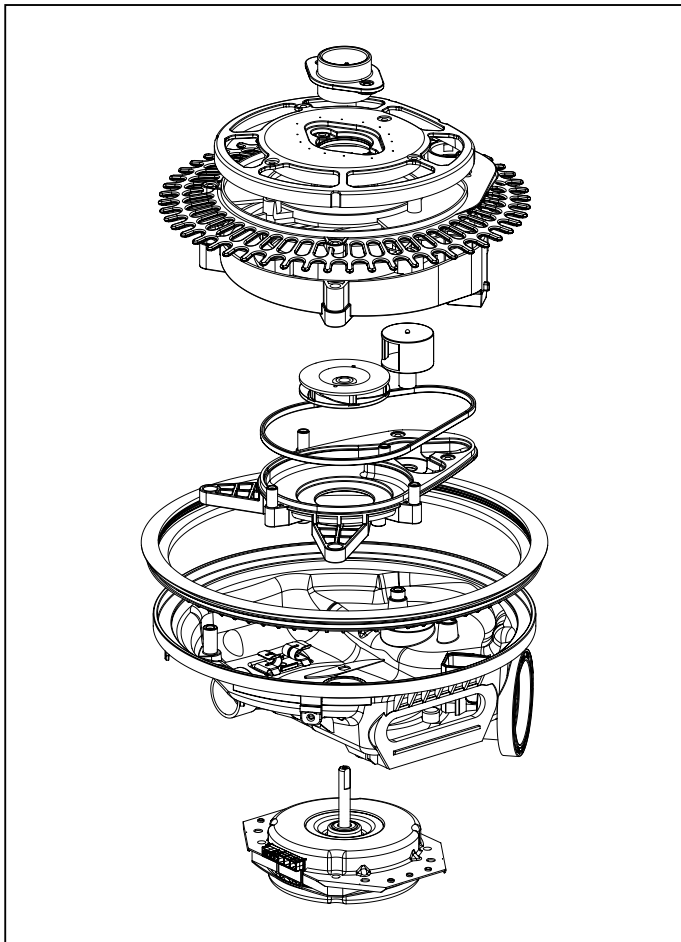

When you reassemble the Sump Assembly, be careful not to kink, tear and take off the seals.

### 17. Holder Supporter, Tub Packing and Hinge Supporter Assembly.

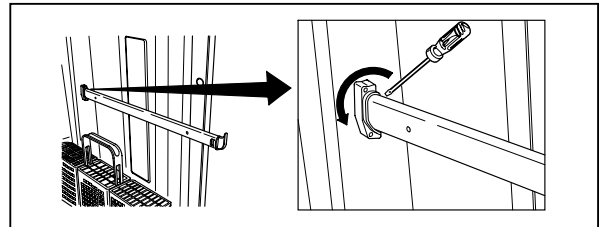



Rotate the screwdriver, after slide it into the gap between Stopper Roller and Rail Roller.

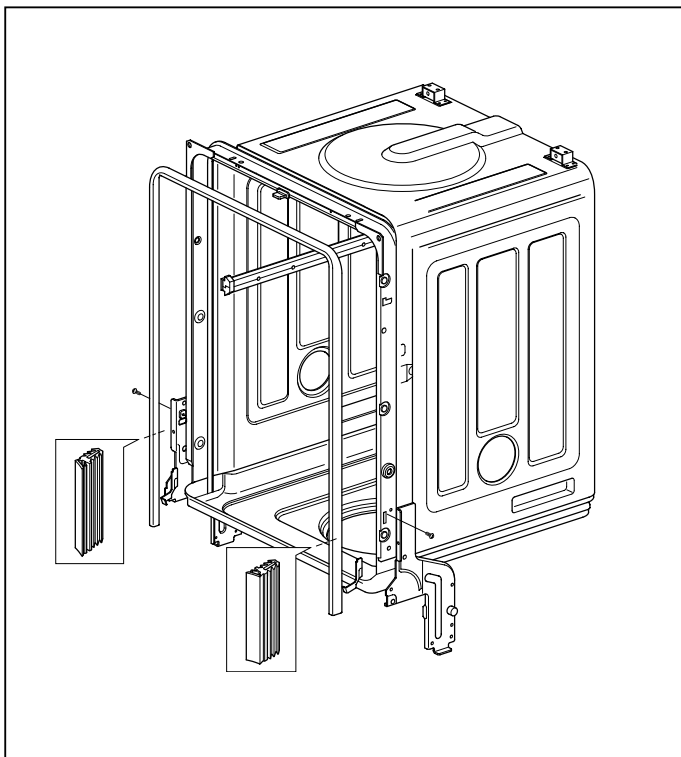

You must take off Stopper Roller(F117) by – screwdriver to change the Rail Assembly. (Stopper Roller could be broken while you are taking off. So you should be careful not to be hurt and have extra stopper rollers ready at servicing at all times)



# 8.TROUBLE SHOOTING METHODS

## A. TROUBLE SHOOTING ACCORDING TO DISPLAYED ERROR MESSAGE

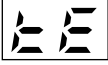
ERROR MESSAGE	POSSIBLE CAUSE FOR ERROR OCCURRENCE	REMEDY
<p><b>INLET ERROR</b></p>  <p>displayed</p> <p><b>Condition</b> Not reached to the normal water level in spite of 10 min. water supply</p>	<ul style="list-style-type: none"> <li>• The Water Supply Tap is closed.</li> <li>• The Water Supply is shut off.</li> <li>• The Inlet Hose is kinked.</li> <li>• The Water Pressure is very low. (below 10 psi)</li> <li>• Inlet Valve is OK?</li> <li>• The filter of Inlet Valve is clogged by impure water.</li> <li>• The Hall sensor is OK?</li> <li>• The Impeller of Air Guide is bound.</li> </ul>	<ul style="list-style-type: none"> <li>• Take action on Water Supply device.</li> <li>• Measure the electric resistance of Inlet Valve. (950-1300 Ω)</li> <li>• Clean the filter of Inlet Valve.</li> <li>• Check the frequency of Inlet Water by the Test Mode.</li> <li>• Replace the Air Braker.</li> </ul>
<p><b>DRAIN ERROR</b></p>  <p>displayed</p> <p><b>Condition</b> Not fully drained out in spite of 5 min. drain operation</p>	<ul style="list-style-type: none"> <li>• The Drain Hose kinked or blocked.</li> <li>• Wiring connection is OK?</li> <li>• The drain outlet of sump is blocked.</li> <li>• The Drain Pump/Motor or circuit is troubled.</li> </ul>	<ul style="list-style-type: none"> <li>• Remove the cause of kink or block.</li> <li>• Check the wiring connection.</li> <li>• Measure the electric resistance of Drain Motor. (20-40 Ω)</li> <li>• Replace the Drain Motor or repair the Circuit.</li> </ul>
<p><b>LEAKAGE ERROR</b></p>  <p>displayed</p> <p><b>Condition</b> The excessive RPM of Washing Motor happened during Wash cycle due to water leakage.</p>	<ul style="list-style-type: none"> <li>• Water leakage in Hose connections.</li> <li>• Water is leaked by damages.</li> <li>• The Motor Water Seal leakage of Sump assembly.</li> <li>• The height of Drain Hose connection (sink-Drain Hose) is not over 20".</li> <li>• Impeller of the Washing Pump is worn away.</li> </ul>	<ul style="list-style-type: none"> <li>• Replace the connections of Hose.</li> <li>• Check the point of damages and repair or replace the related parts.</li> <li>• Read the Installation Instructions (page 9) and fix it to the recommended Height.</li> <li>• Replace the Impeller of the Washing Pump.</li> </ul>

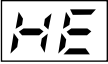
ERROR MESSAGE	POSSIBLE CAUSE FOR ERROR OCCURRENCE	REMEDY
<p><b>EXCESS ERROR</b></p>  <p>displayed</p> <p><b>Condition</b> Excessive water is supplied than normal water level.(Automatically drain Pump operated.)</p>	<ul style="list-style-type: none"> <li>• The Inlet Valve is troubled.</li> <li>• The Controller is troubled.</li> </ul>	<ul style="list-style-type: none"> <li>• Replace the Inlet Valve.</li> <li>• Repair or replace the Controller.</li> </ul>
<p><b>THERMAL ERROR</b></p>  <p>displayed</p> <p><b>Condition</b> The resistance of thermistor not normally out put.</p>	<ul style="list-style-type: none"> <li>• The Inlet Water Temperature is very high. (over 194 °F)</li> <li>• Wiring connection is OK?</li> <li>• The Thermistor is OK?</li> </ul>	<p>Check the temperature. (Test Mode)</p> <ol style="list-style-type: none"> <li>1) If the temperature is displayed, <ol style="list-style-type: none"> <li>① adjust the Inlet Water Temperature to 120 °F.</li> </ol> </li> <li>2) If the temperature is not displayed, <ol style="list-style-type: none"> <li>① check the wiring connection.</li> <li>② check the electric resistance of Thermistor. (11~14k Ω at 77 °F)</li> <li>③ Replace the PCB.</li> </ol> </li> </ol>
<p><b>MOTOR ERROR</b></p>  <p>displayed</p> <p><b>Condition</b> The Motor is working abnormally.</p>	<ul style="list-style-type: none"> <li>• Wiring connection is OK?</li> <li>• The Impeller of Washing Pump is locked.</li> <li>• The rotor of Washing Motor is locked.</li> <li>• The Blade is locked.</li> </ul>	<ul style="list-style-type: none"> <li>• Check the wiring connection.</li> <li>• Replace the cause of restriction.</li> <li>• Replace the Washing Motor.</li> <li>• Replace the PCB.</li> </ul>
<p><b>HEATER ERROR</b></p>  <p>displayed</p> <p><b>Condition</b> The water is not heated or the temperature in the Tub is overheated to over 194℉F</p>	<ul style="list-style-type: none"> <li>• The Circuit of Heater is troubled.</li> <li>• The Thermistor is troubled.</li> <li>• The Heater is shorted.</li> <li>• The Relay Circuit is troubled.</li> </ul>	<ul style="list-style-type: none"> <li>• Repair the Circuit of Heater.</li> <li>• Replace the Thermistor.</li> <li>• Replace the Heater.</li> <li>• Repair the Relay Circuit..</li> </ul>

---

## B. STEAM GENERATOR ERROR MESSAGE

- Steam Generator Error mode is not displayed in normal condition and it can be confirmed by following additional operation.
- To confirm steam generator error, press the **DELAY START** and **RINSE ONLY** buttons simultaneously.
- When Steam Generator is out of order, dishwasher operates the selected cycle without steam.

ERROR MESSAGE	CONDITION	REMEDY
<b>00 : E0</b>	<ul style="list-style-type: none"><li>• The normal condition</li></ul>	
<b>00 : E1</b>	<ul style="list-style-type: none"><li>• The generator heater temperature is high. (over 239°F )</li></ul>	<ul style="list-style-type: none"><li>• Check the water level sensor and thermistor check.</li></ul>
<b>00 : E2</b>	<ul style="list-style-type: none"><li>• The water leveling sensor is working abnormally.</li></ul>	<ul style="list-style-type: none"><li>• Check the wiring connection and water level sensor.</li></ul>
<b>00 : E3</b>	<ul style="list-style-type: none"><li>• Not reached to the normal water level.</li></ul>	<ul style="list-style-type: none"><li>• Check the inlet valve and sensor connection.</li></ul>
<b>00 : E4</b>	<ul style="list-style-type: none"><li>• The generator heater temperature is low. (lower than 158°F )</li></ul>	<ul style="list-style-type: none"><li>• Check the heater and thermistor.</li></ul>
<b>00 : E5</b>	<ul style="list-style-type: none"><li>• The normal condition</li></ul>	

## C. TROUBLE DIAGNOSES AND REPAIR BY SYMPTOM

No Power on when the power button pressed.

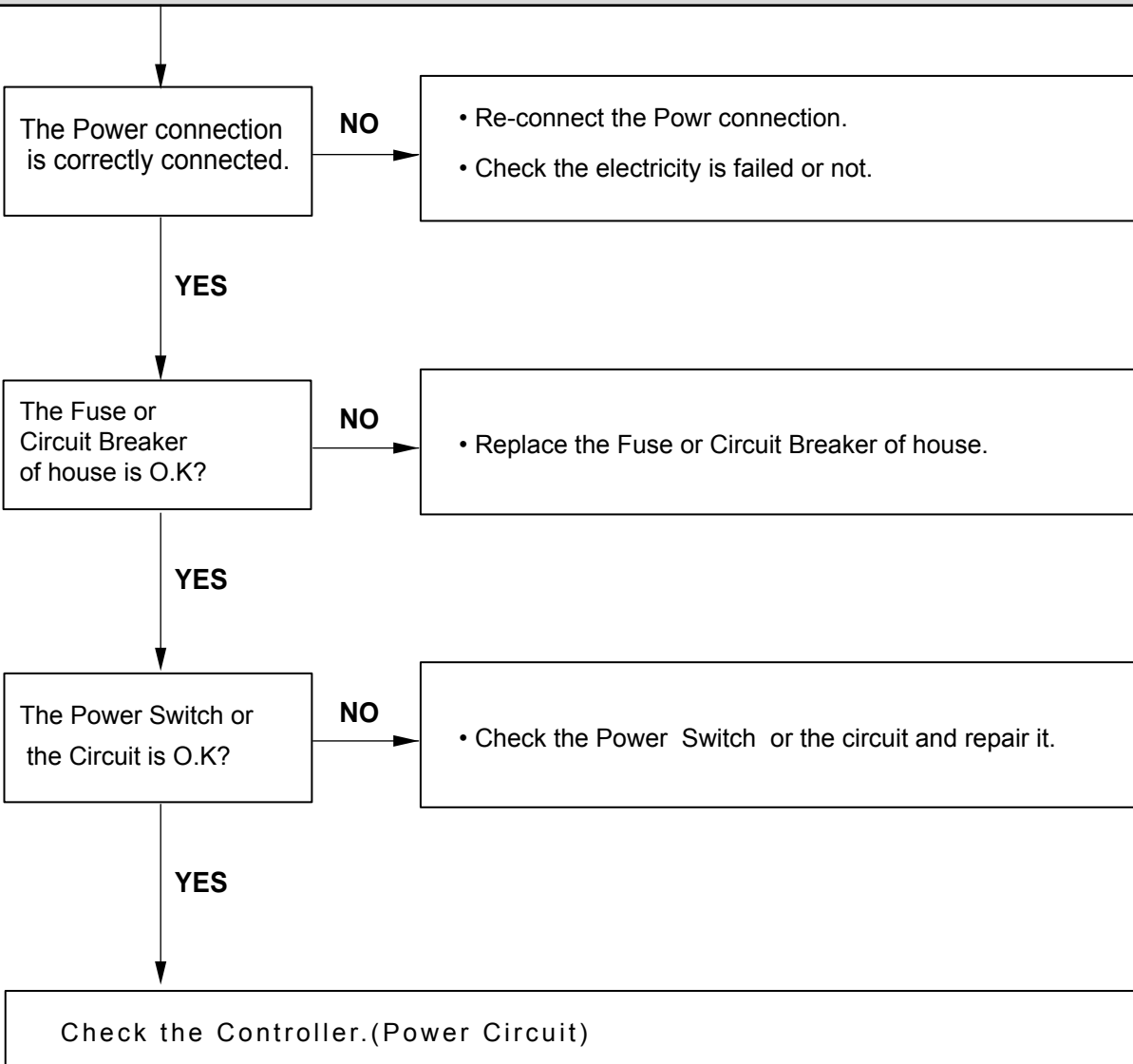



**The Wash Pump/Motor does not run.**

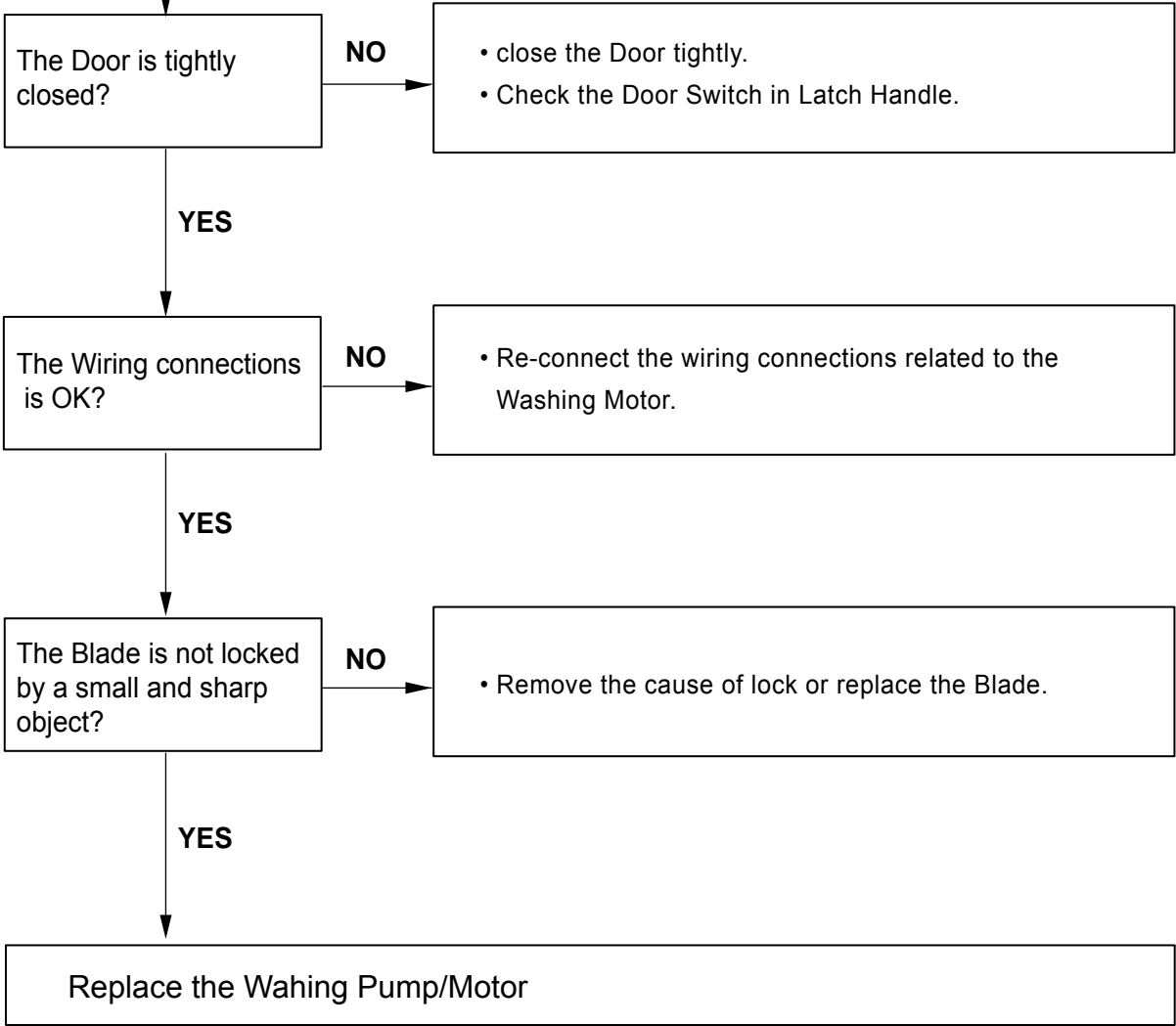

---

## Washing Results are not Satisfactory

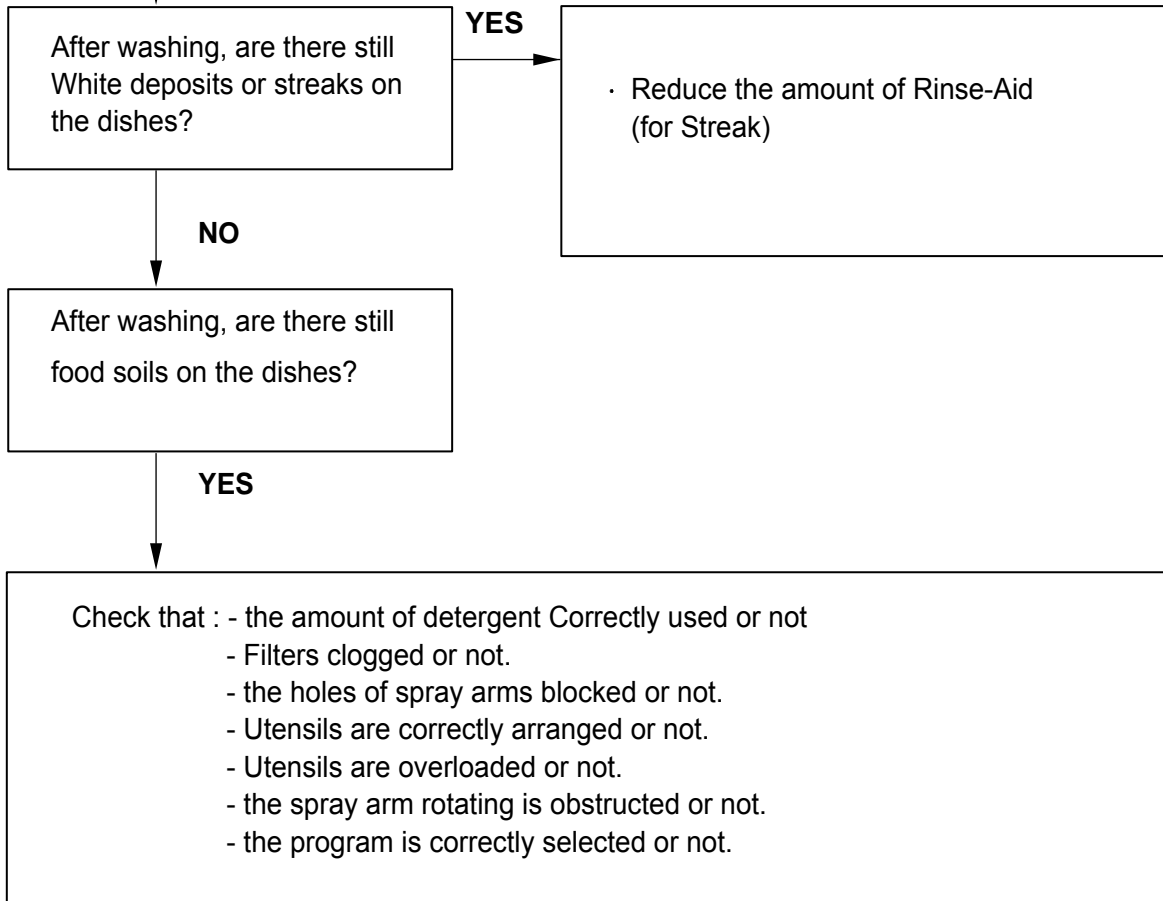

## Dry Results are not satisfactory

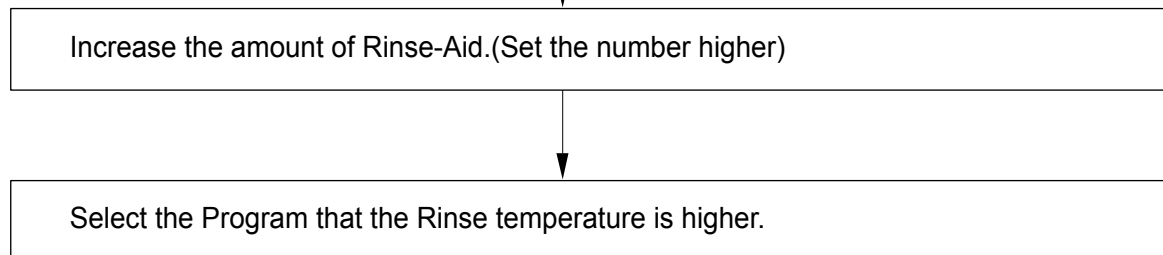

---

**Power Button not automatically off after operation.**

Check the button is blocked by foreign materials.

Check the Power Switch.(Replace it, if necessary.)

Check the Controller.(Replace it, if necessary.)

# 9. INSTALLATION INSTRUCTION

## Step 1: PREPARE CUPBOARD OPENING

1. This dishwasher is designed to fit a standard dishwasher opening as shown below.
2. Select a location as close to sink as possible for easy connections to water and drain lines.
3. The dishwasher should not be installed more than 10 ft. (3m) from the sink for proper drainage.
4. If dishwasher is to be installed in a corner, a minimum of 2 in. (50mm) is required between the dishwasher and an adjacent wall.

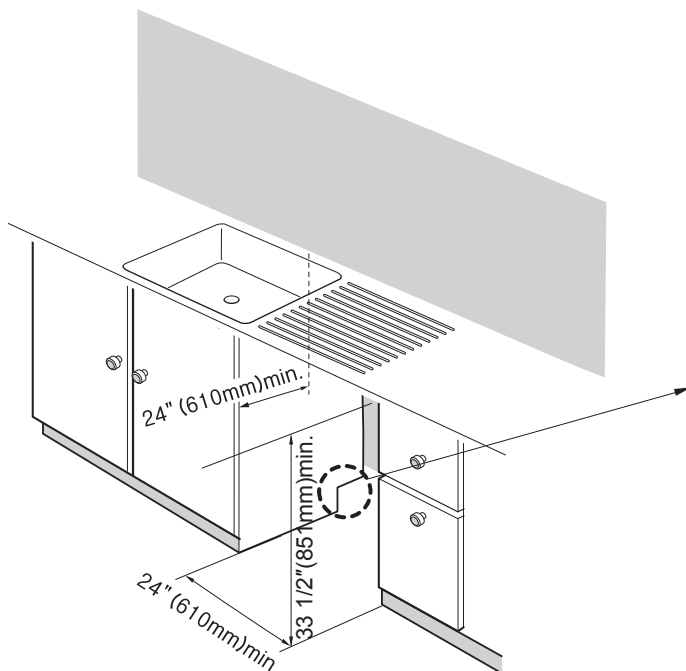

**If dishwasher will sit directly on subflooring, subfloor should be sealed with a waterproof paint or sealer to prevent damage from steam.**

Drill a 1-1/2" (38mm) dia hole or cut out for drain hose, inlet hose and electrical cables on either side.

approx. 4" (100mm, W) X 4" (100mm, H)  
These openings must be within 4" (100mm) from the floor and 1-5/8" (40mm) from the back wall. If there is a floor in the cabinet under the sink, it will also be necessary to drill or cut through the floor to connect the water and drain under the sink.

- Ensure the floor under the dishwasher is at the same level as the rest of the room to allow for any service requirements.

## Step 2: PREPARE THE ELECTRICAL WIRING

### ⚠ WARNING

For personal safety, remove house fuse or open circuit breaker before installation. Do not use an extension cord or adapter plug with this dishwasher. Electrical and grounding connections must comply with the national electrical code/provincial and municipal code and/or other local codes.

1. This appliance must be operated with correct voltage as shown in this manual and on the rating plate, and connected to an individual, properly grounded branch circuit, protected by time delay fuse. Wiring must be 3 wires including ground.
2. The wiring or cord should be in an accessible location adjacent to, and not behind the dishwasher and within 4 ft. (1.2m) of the dishwasher side.
3. The wiring or cord must be grounded properly, if in doubt, have it checked by a qualified electrician. No other appliance shall be connected to the same outlet by a double adapter or similar plug.
4. The wiring or cord must be oriented as shown in Figure A below.
5. Check the dishwasher for any damage before trying to install it.
6. Make sure water line and Electrical line are oriented in the bottom channels as shown in the figure below.  
If you find any damage to the dishwasher, Please contact your dealer or builder immediately.

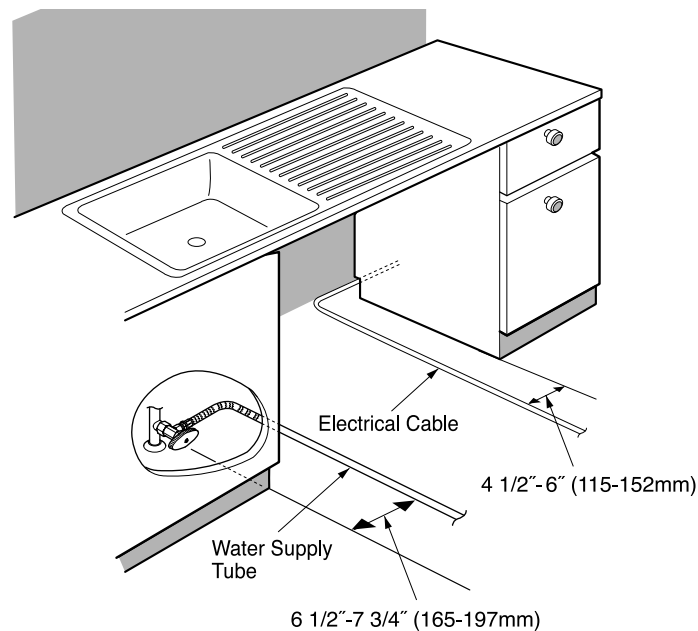

### Step 3: PREPARE THE WATER SUPPLY CONNECTION

1. This dishwasher may be connected to either hot or cold water. If the water can not be maintained below 149°F (65 °C), the dishwasher must be connected to cold water.
2. When connecting the dishwasher water line, sealing tape or compound should be used to avoid leaks.
3. When connecting the dishwasher water line, the house supply should be shut off.
4. The Water Supply Tube must be oriented as shown in Figure A on page 6.

### Step 4: PREPARE DISHWASHER FOR INSTALLATION

1. Adjust the legs to the required height to fit properly under the countertop as shown below.
2. Check the level of dishwasher by using level.

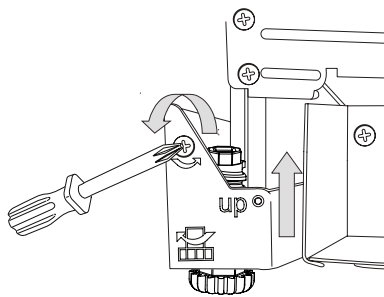

- Left side – turn the adjusting screw counterclockwise to lower the leg and raise the rear of the dishwasher.

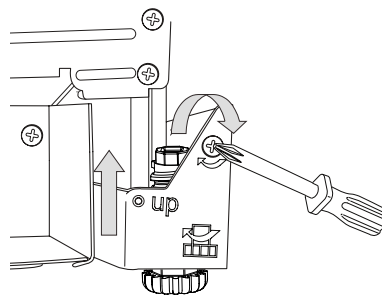

- Right side – turn the adjusting screw clockwise to lower the leg and raise the rear of the dishwasher.

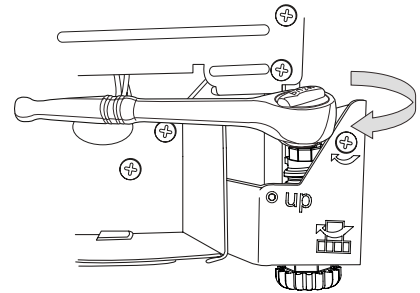

- Front feet can be adjusted from the top using a 1/4" square drive wrench.

## Step 5: INSTALL THE DISHWASHER IN CUPBOARD

1. Remove the Lower Cover and orient dishwasher as shown below.
2. Before sliding the dishwasher into the cupboard opening, make all necessary height adjustments using the legs.
3. Slide the dishwasher into the cabinet opening carefully. Make sure that the drain hose inside the cabinet is not kinked.
4. Follow the instruction as in Figure B.

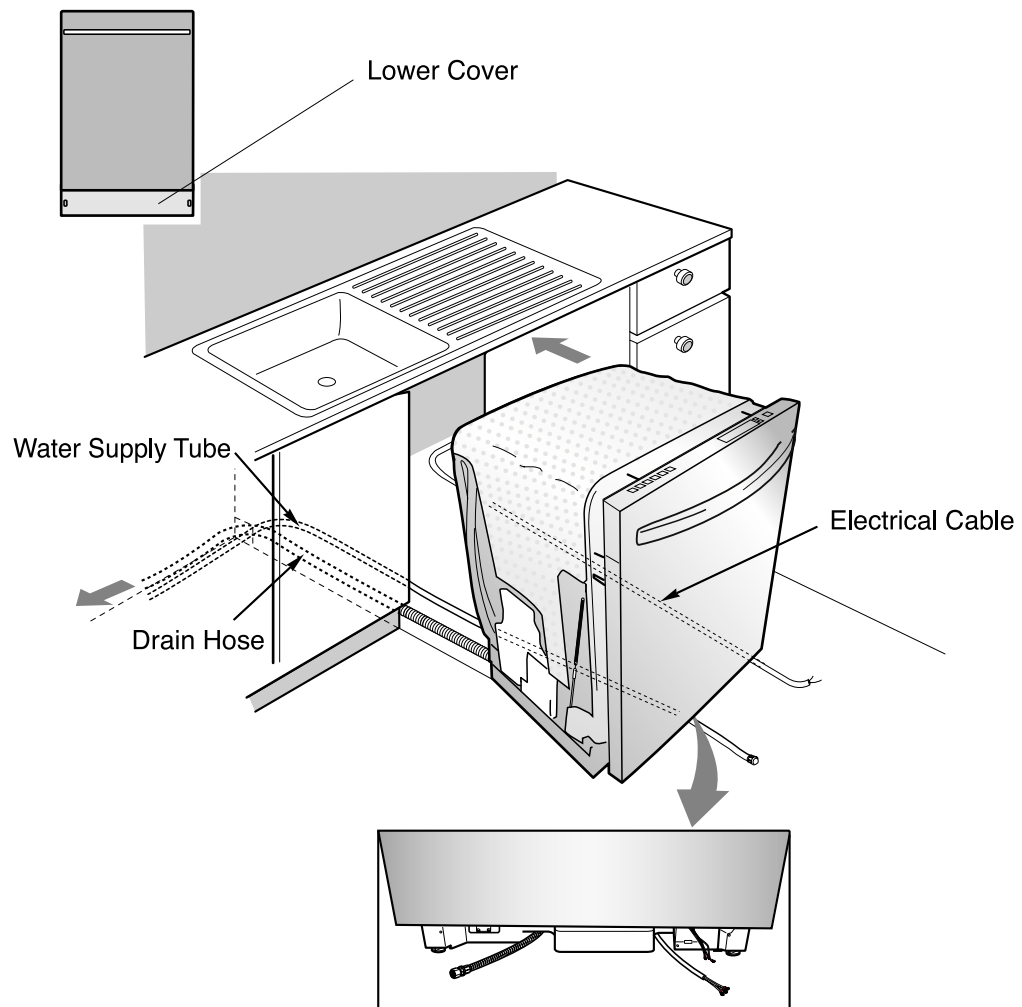

## Step 6: DRAIN LINE CONNECTION

1. If the end of the drain hose does not fit to the drain line, use an adapter (not supplied) that must be resistant to heat and detergent and may be obtained from a plumbing shop.
2. There are 2 typical connections as shown in Figures C & D.
  - ① There may be other options than shown here for connection the drain hose. The drain connection must meet local plumbing regulations.
  - ② The S trap spigot must be drilled out cleanly and free of obstruction to its maximum internal diameter, if used for drainage.
  - ③ To prevent syphoning, one of the following instruction methods must be followed:

**Figure C:** Connection to Disposer or waste Tee.

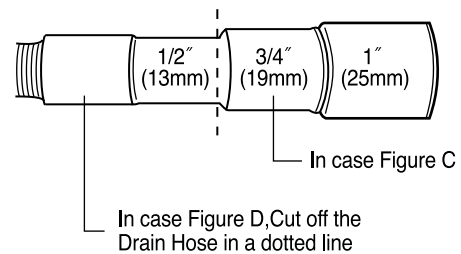
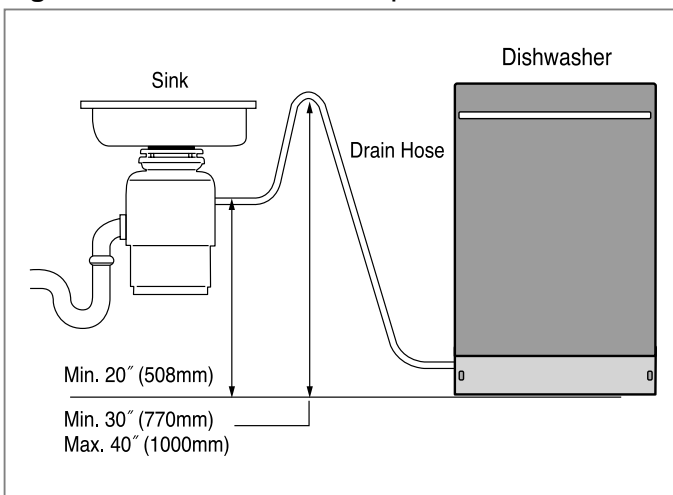

**Figure D:** Connection to Air Gap.

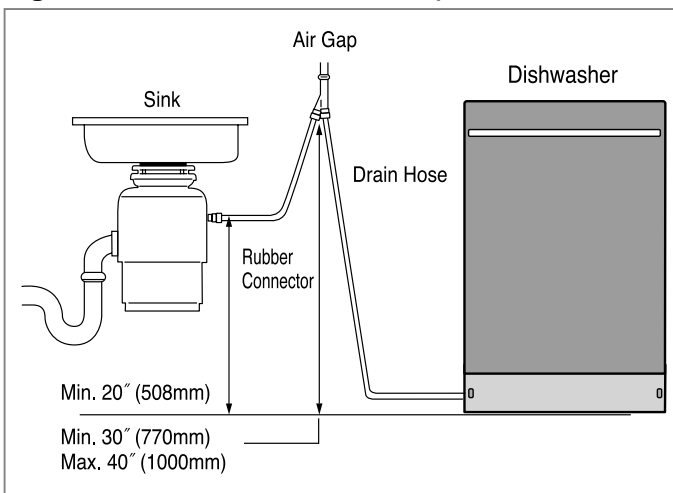

## Drain Requirements

- Follow local codes and ordinances.
- Do not exceed 10 ft. (3m) distance to drain.
- Do not connect drain lines from other devices to the dishwasher drain hose.



## Step 7: WATER SUPPLY CONNECTION

1. When connecting, sealing tape or sealing compound should be used to avoid water leaks.
2. Before connecting, turn off the water supply.
3. After fitting the Elbow into the Inlet Valve, slide the Flexible Stainless Tube or Copper Tube into the Elbow.
4. Tighten the nut and make sure that the line is not kinked or sharply bent.

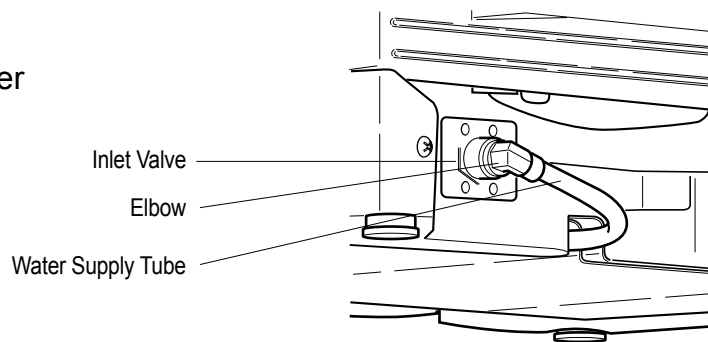

## Step 8: ELECTRICAL POWER CONNECTION

1. Before beginning, turn off electrical power to the unit at the circuit breaker.
2. Remove the Junction Cover and then Install the Strain Relief.
3. Twist Wire Connectors tightly on the wires. Wrap each connection with Electrical tape.
4. Check again and make sure that all wires are connected correctly, black to black, white to white, green to green (ground to ground).
5. Replace the Junction Cover.

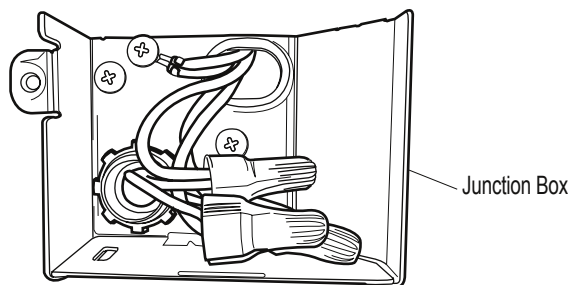
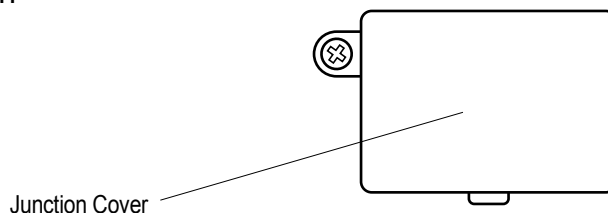

---

## **Step 9: FINAL CHECKS**

1. Turn electrical power back on at the circuit breaker.
2. Turn house water supply back on.
3. Operate the dishwasher through one cycle (Quick cycle is recommended) to check for water leaks and operating conditions.
4. Replace the Lower Cover.

# 10. EXPLODED VIEW

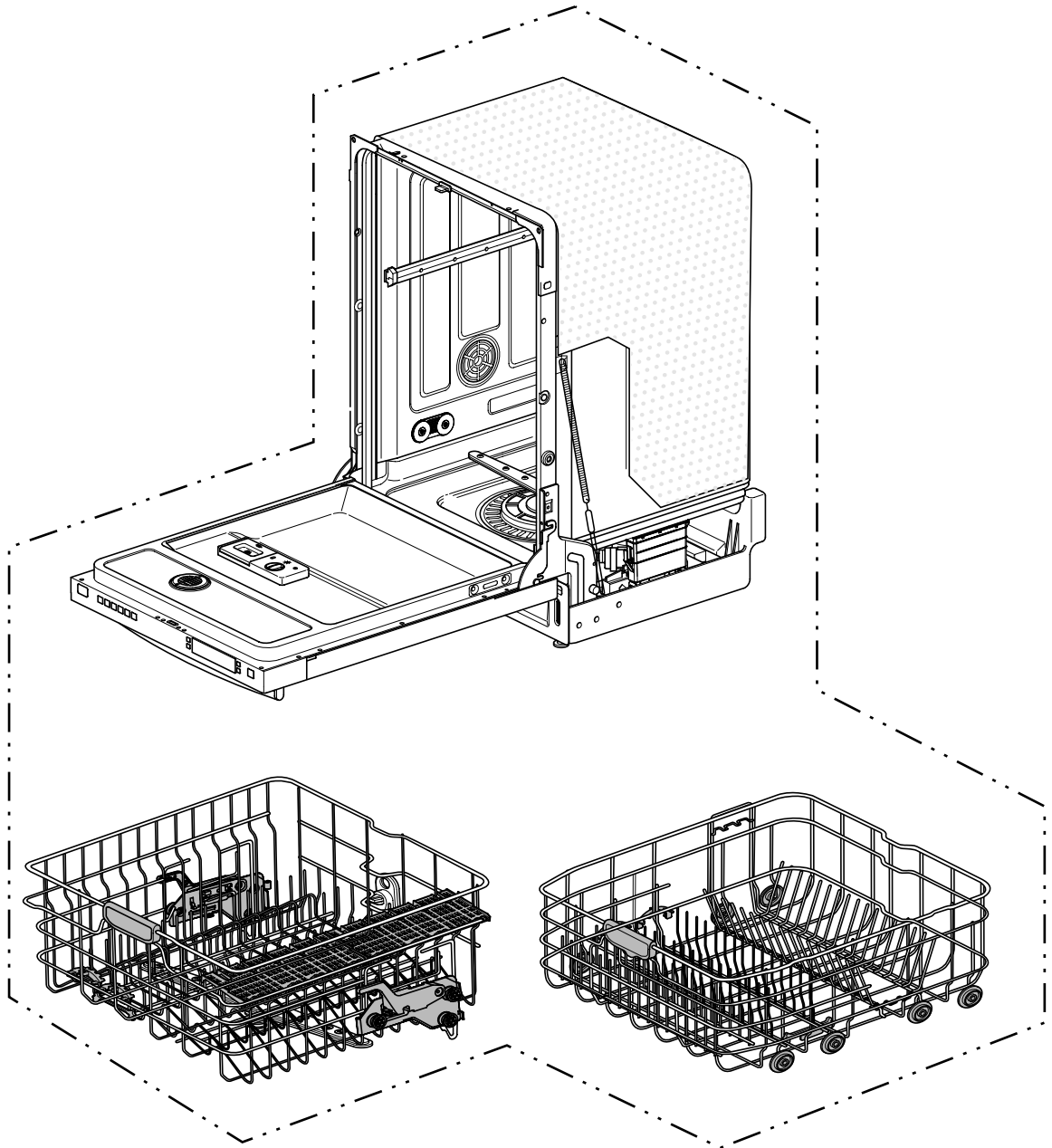

**"The following parts are not illustrated"**

	Description	Loc No.
<b>Printed materials</b>	*Owner's Manual	G001
	*Energy Label	G002
	*Service Manual	G004

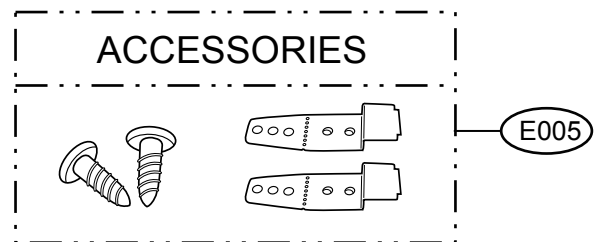

EXPLODED VIEW

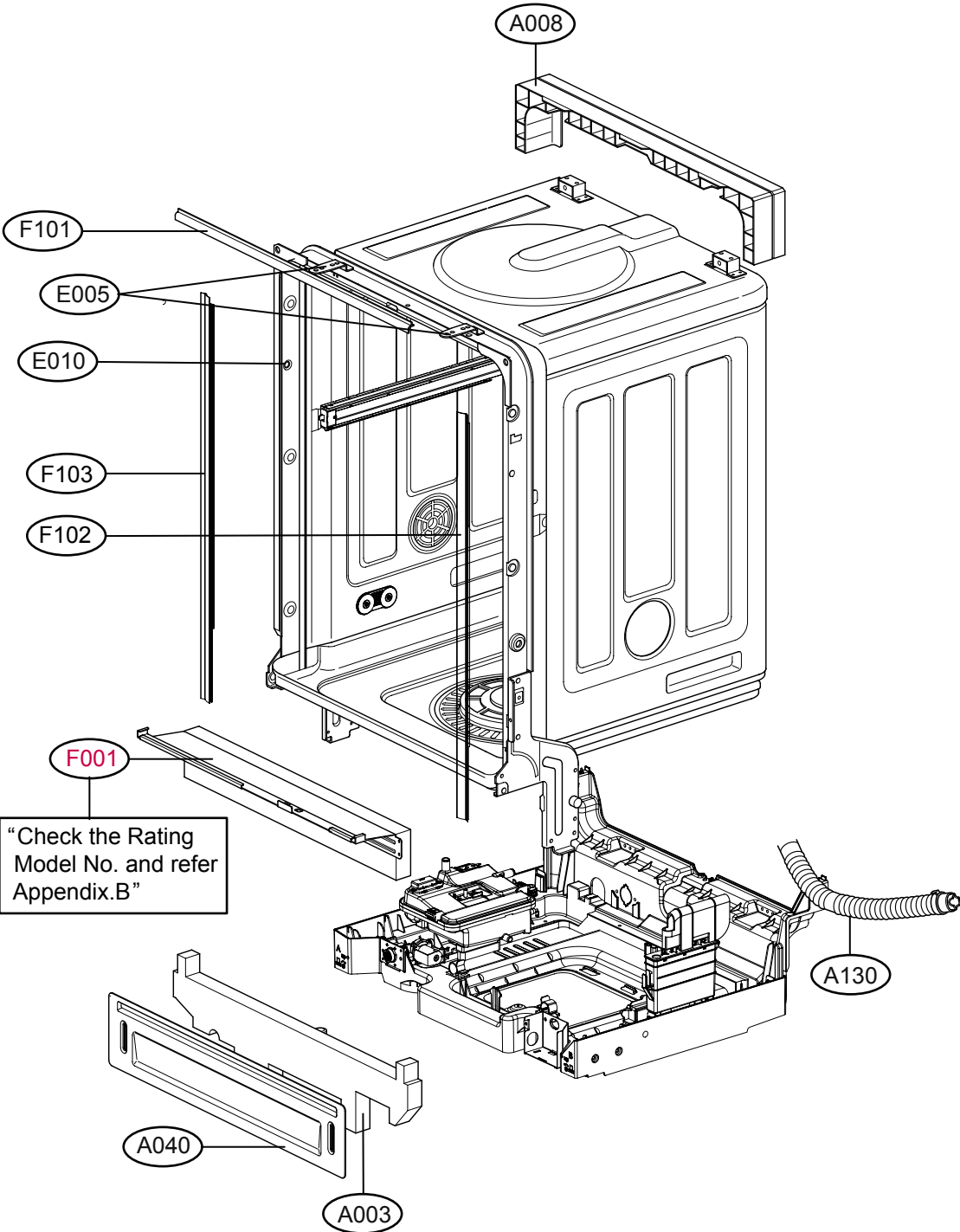

# EXPLODED VIEW - TUB ASSEMBLY

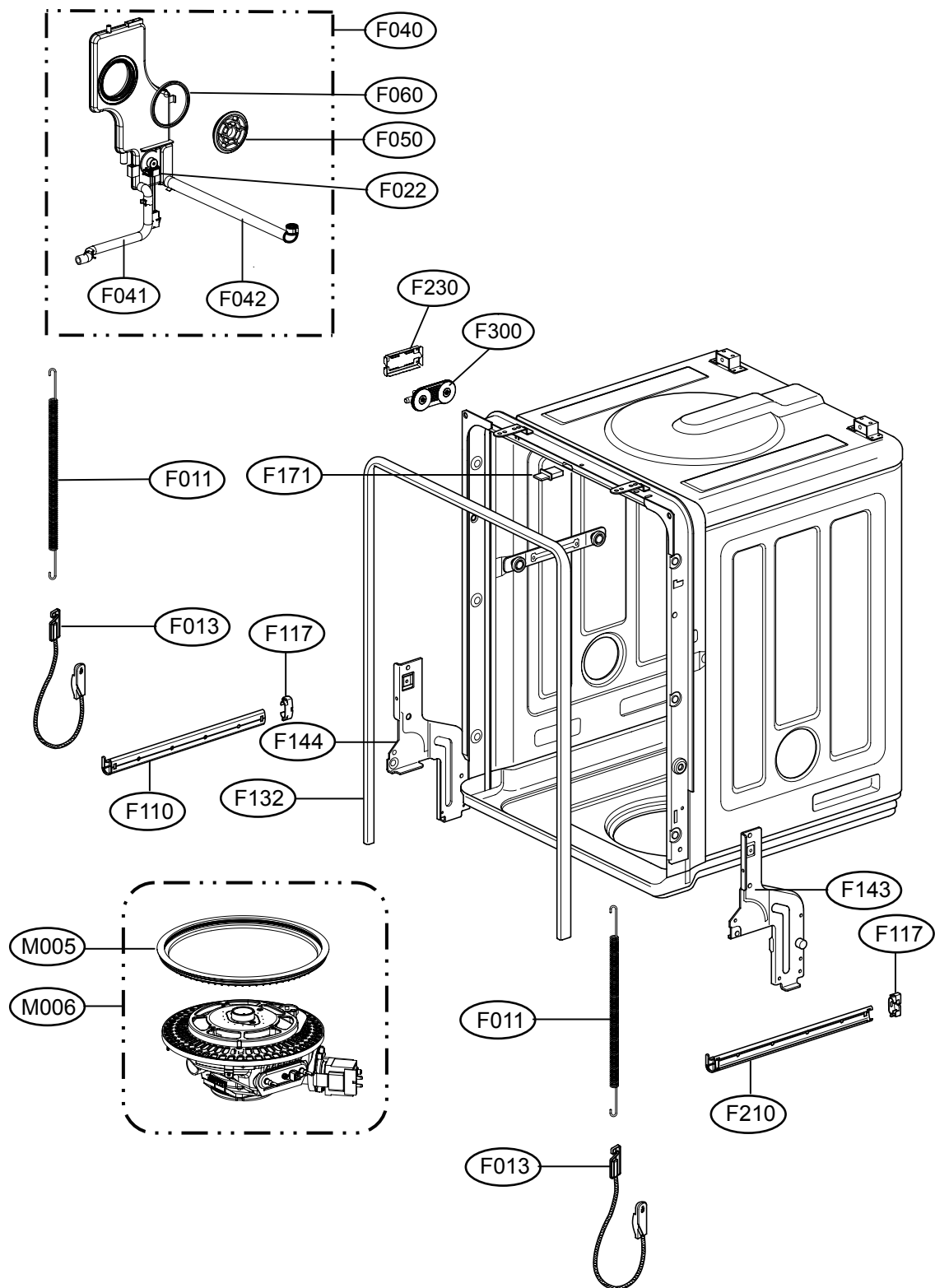

# EXPLODED VIEW - RACK ASSEMBLY

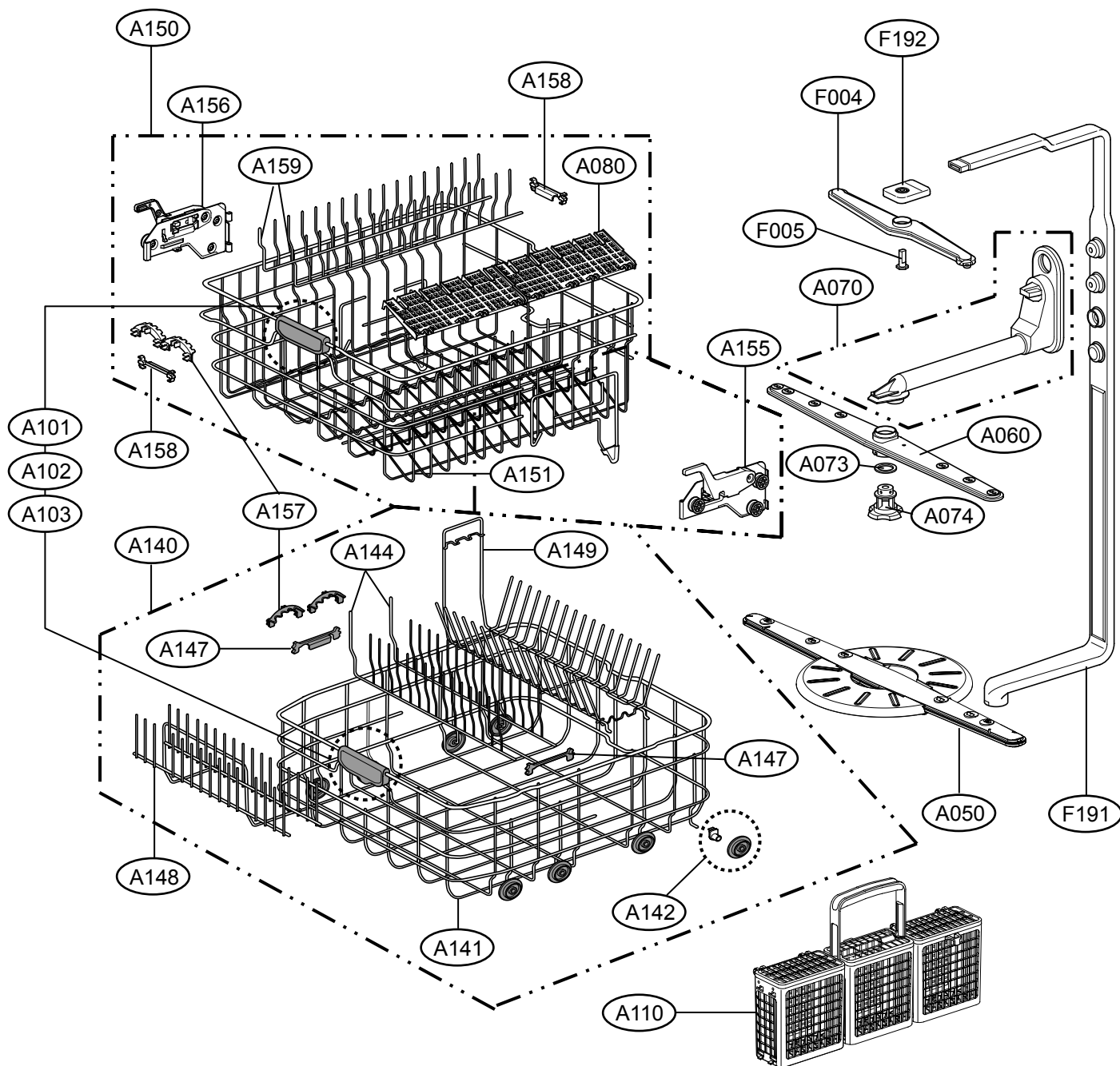

## EXPLODED VIEW - PANEL ASSEMBLY

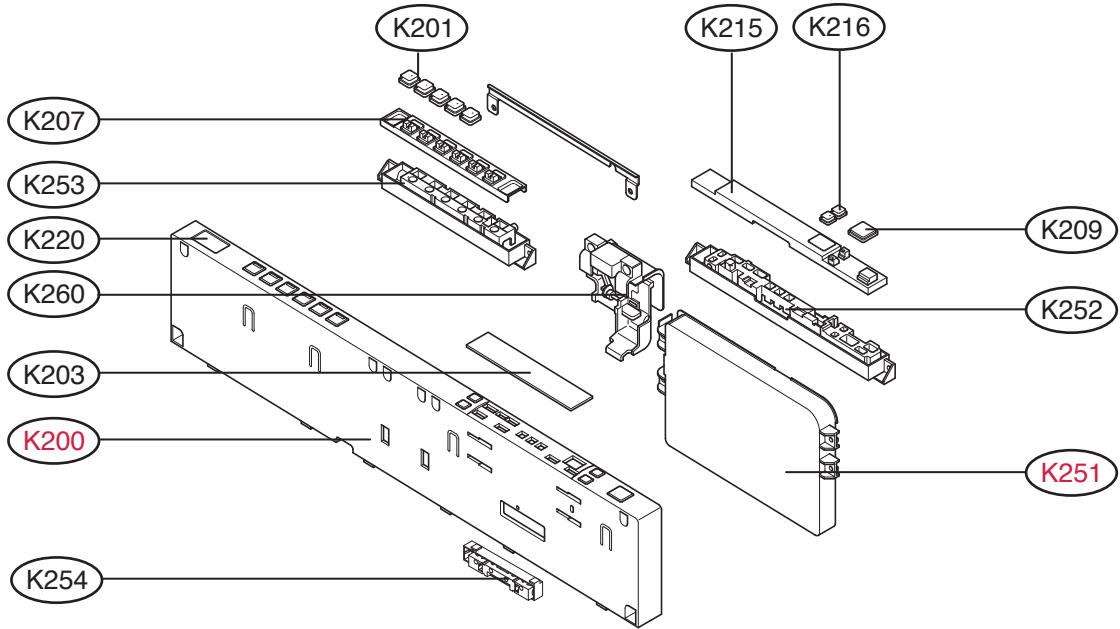

## EXPLODED VIEW - BASE ASSEMBLY

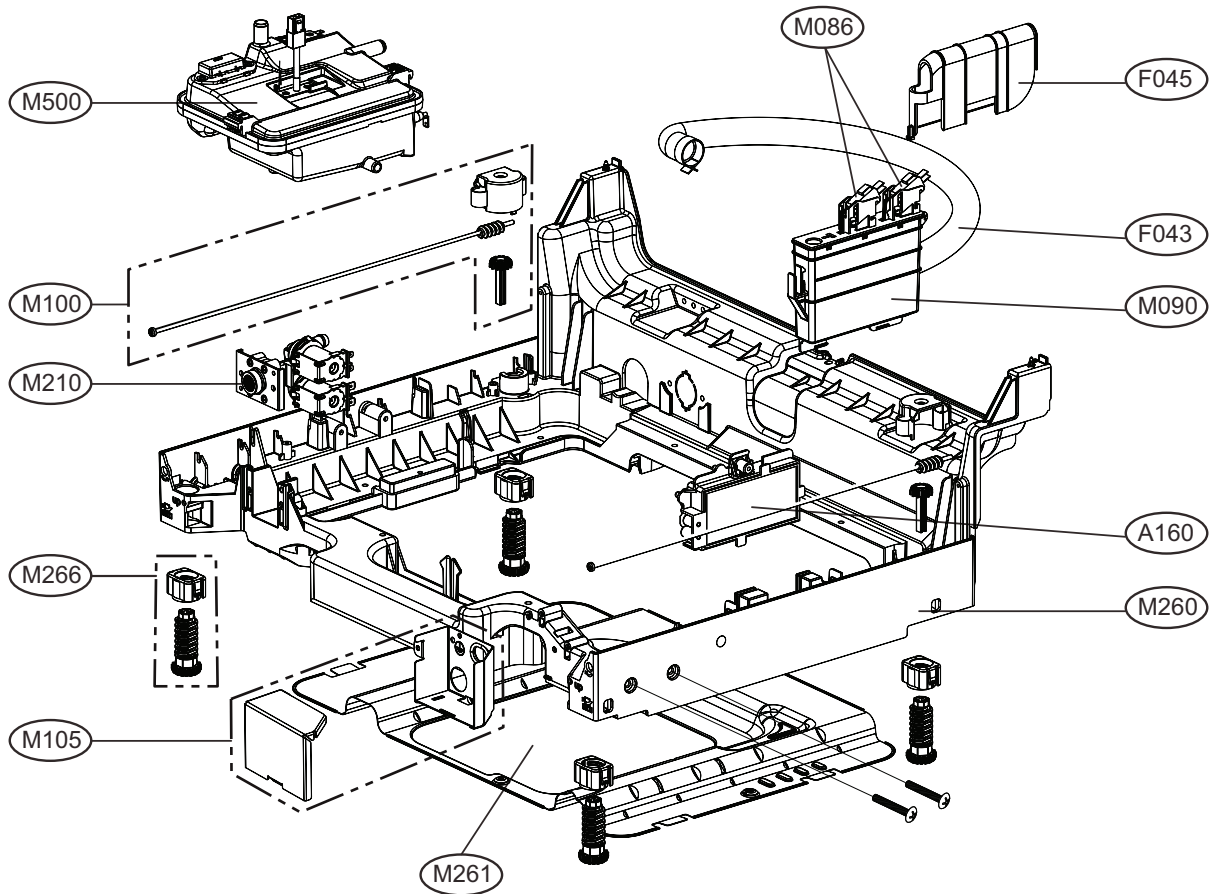

# EXPLODED VIEW - DOOR ASSEMBLY

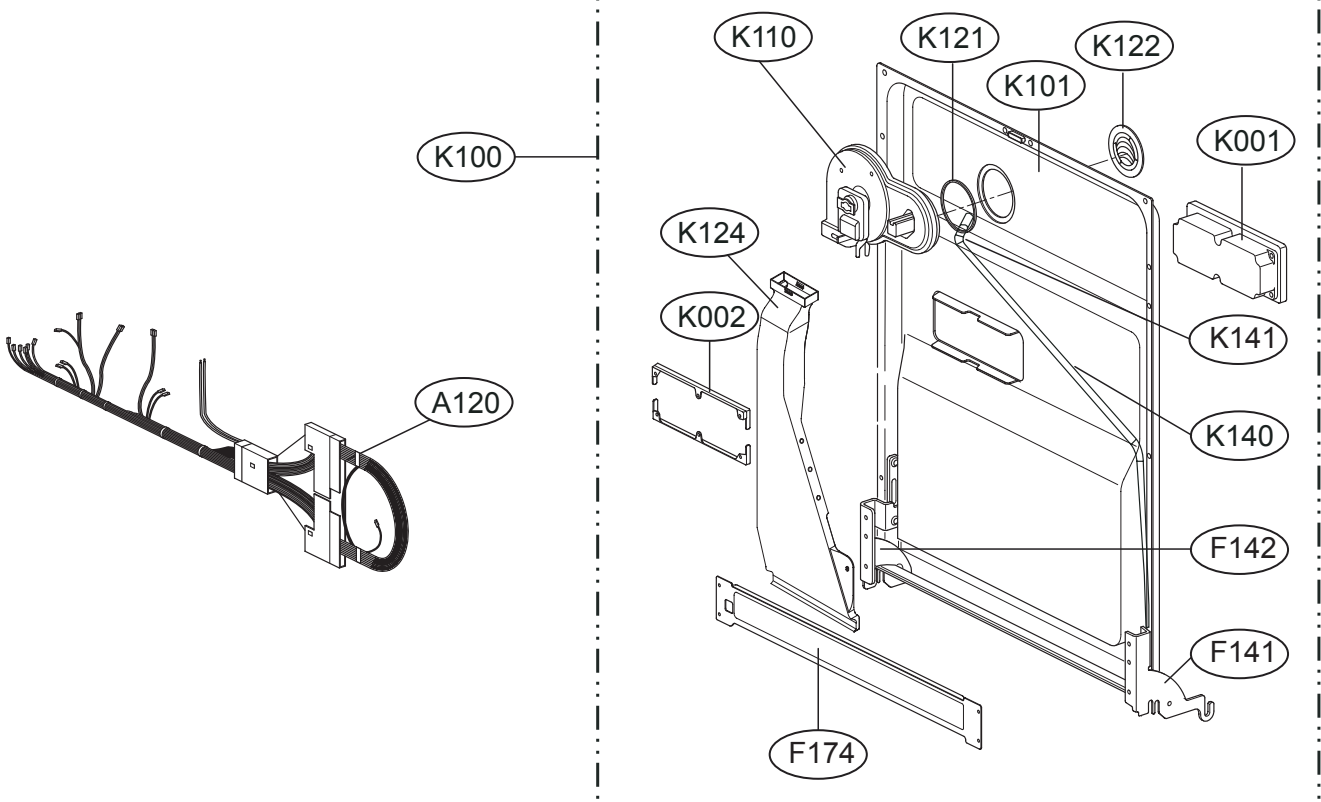
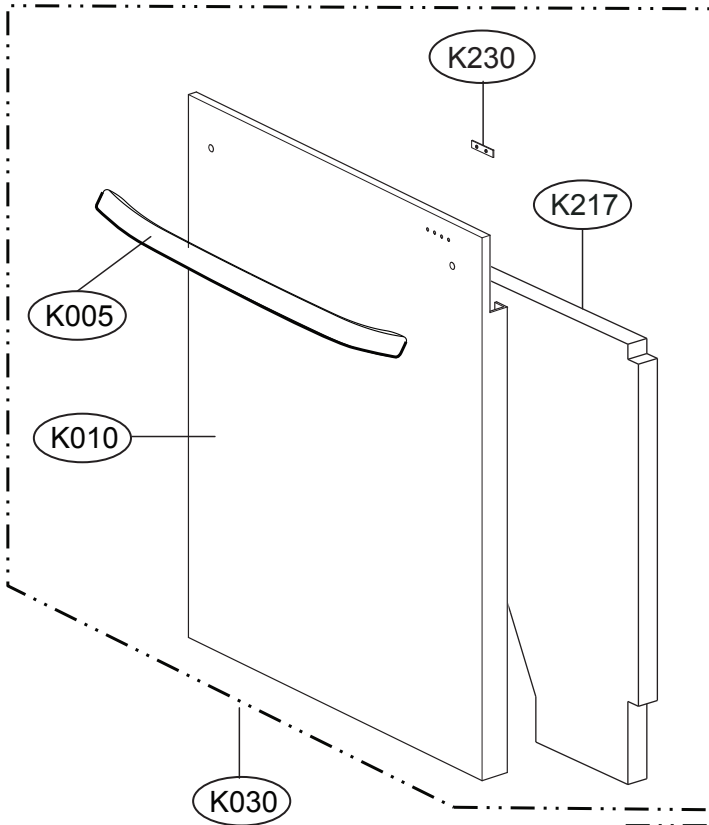



EXPLODED VIEW - SUMP ASSEMBLY

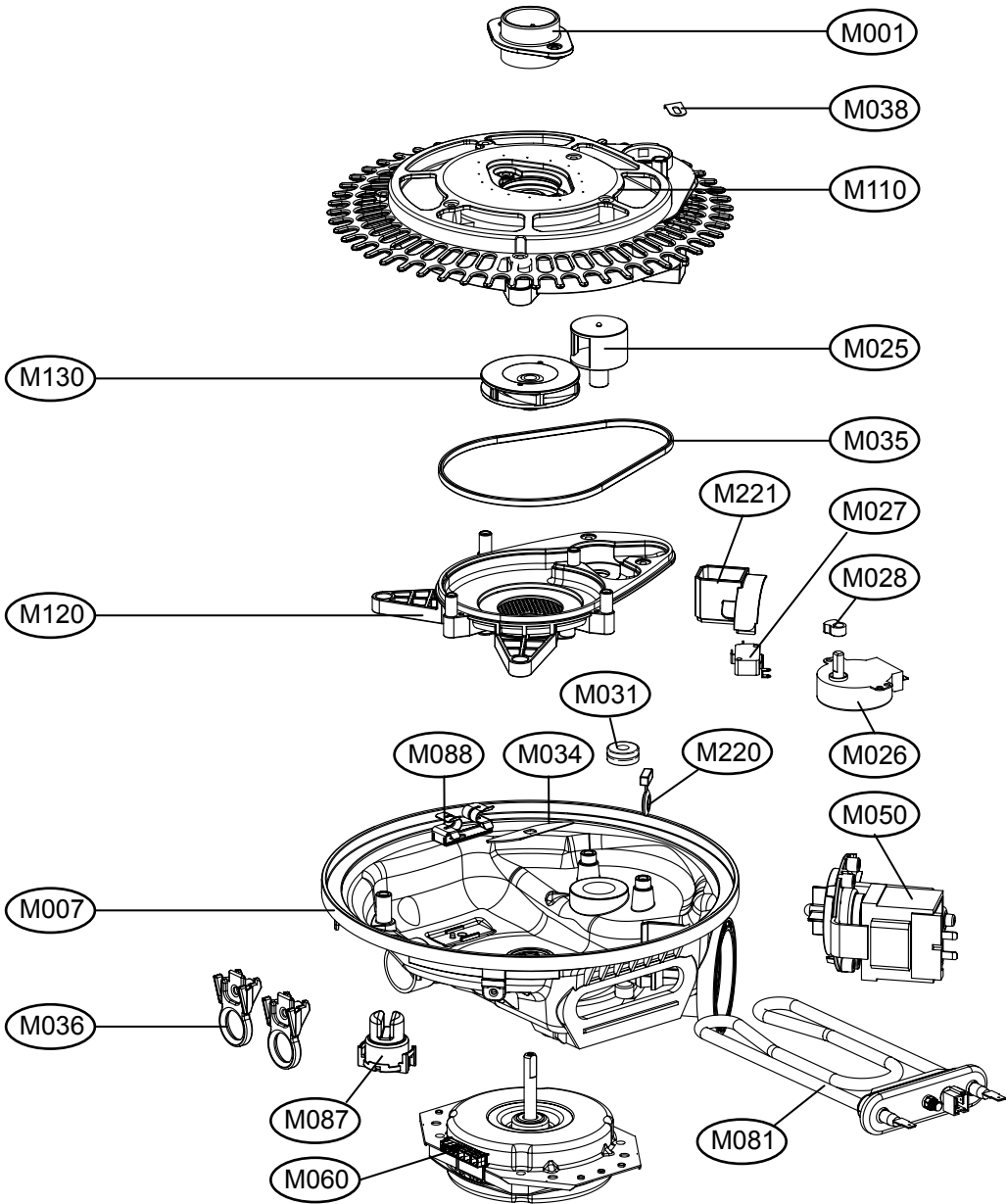



# MEMO

---



**LG Electronics Inc.**

P/No. : MFL37554807