

This Owner's Manual is provided and hosted by [Appliance Factory Parts](#).



Kenmore 795.58813 Owner's Manual

[Shop genuine replacement parts for Kenmore
795.58813](#)



* The color vary in each model

[Find Your Kenmore Refrigerator Parts - Select From 665 Models](#)

----- Manual continues below -----



SXS REFRIGERATOR

REFRIGERATOR SERVICE MANUAL

CAUTION
BEFORE SERVICING THE UNIT,
READ THE SAFETY PRECAUTIONS IN THIS MANUAL.

MODELS:

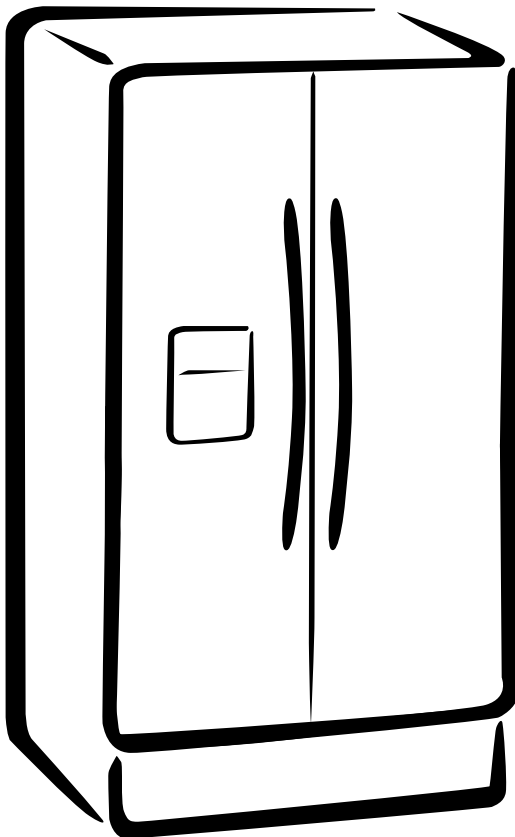

795.58812.900
795.58813.900
795.58814.900
795.58816.900
795.58819.900

CONTENTS

WARNINGS AND SAFETY PRECAUTIONS	3
1. SPECIFICATIONS	4
2. PARTS IDENTIFICATION	5
3. HOW TO INSTALL REFRIGERATOR	6
4. MICOM FUNCTION	10
5. CIRCUIT	19
6. EXPLANATION FOR MICOM CIRCUIT	20
7. ICEMAKER AND DISPENSER WORKING PRINCIPLES AND REPAIR.....	26
8. TROUBLE DIAGNOSIS	31
9. HOW TO DISASSEMBLE AND ASSEMBLE.....	68
10. EXPLODED VIEW AND	73
795.58812/58813/58814/58816/58819.900	80

WARNINGS AND PRECAUTIONS FOR SAFETY

Please observe the following safety precautions to use the refrigerator safely and correctly and to prevent accident or injury when servicing.

1. Be careful of an electric shock. Disconnect power cord from wall outlet and wait for more than three minutes before replacing PWB parts. Shut off the power whenever replacing and repairing electric components.
2. When connecting power cord, please wait for more than five minutes after power cord was disconnected from the wall outlet.
3. Please check if the power plug is pressed by the refrigerator against the wall. If the power plug was damaged, it could cause fire or electric shock.
4. If the wall outlet is overloaded, it may cause a fire. Please use a dedicated circuit for the refrigerator.
5. Please make sure the outlet is properly grounded. Particularly in a wet or damp area.
6. Use standard electrical components.
7. Make sure hooks are correctly engaged. Remove dust and foreign materials from the housing and connecting parts.
8. Do not fray, damage, run over, kink, bend, pull out, or twist the power cord.
9. Please check for evidence of moisture intrusion in the electrical components. Replace the parts or mask with insulation tape if moisture intrusion was confirmed.
10. Do not touch the icemaker with hands or tools to confirm the operation of geared motor.
11. Do not suggest that customers repair their refrigerator themselves. This work requires special tools and knowledge. Non-professionals could cause fire, injury, or damage to the product.
12. Do not store flammable materials such as ether, benzene, alcohol, chemicals, gas, or medicine in the refrigerator.
13. Do not put anything on top of the refrigerator, especially something containing water, like a vase.
14. Do not put glass bottles with full of water into the freezer. The contents will freeze and break the glass bottles.
15. When you scrap or discard the refrigerator, remove the doors and dispose of it where children are not likely to play in or around it.

1. SPECIFICATIONS

1-1 DISCONNECT POWER CORD BEFORE SERVICING IMPORTANT - RECONNECT ALL GROUNDING DEVICES

All parts of this appliance capable of conducting electrical current are grounded. If grounding wires, screws, straps, clips, nuts or washers used to complete a path to ground are removed for service, they must be returned to their original position and properly fastened.

1-2 IMPORTANT NOTICE

This information is intended for use by individuals possessing adequate backgrounds of electrical, electronic and mechanical experience. Any attempt to repair a major appliance may result in personal injury and property damage. The manufacturer or seller cannot be responsible for the interpretation of this information, nor can it assume any liability in connection with its use.

1-3 ELECTRICAL SPECIFICATIONS

Temperature Control (Position: MID).....	-6°F to +8°F
Defrost Control.....	Automatic
Defrost Thermostat.....	50°F
Electrical Rating: 115VAC, 60Hz.....	1-7 A
Maximum Current Leakage.....	0.5mA
Maximum Ground Path Resistance.....	0.1 Ohms
Energy Consumption.....	27 cu.ft. 590kWh/yr (Energy Star)

1-4 NO LOAD PERFORMANCE

Control Position: MID/MID

And ambient of:.....	70°F	90°F
Fresh Food, °F.....	33°F to 41°F	33°F to 41°F
Frozen Food, °F.....	-4°F to +4°F	45%-60%
Percent Running Time.....		

1-5 REFRIGERATION SYSTEM

Minimum Compressor Capacity Vacuum.....	21 in
Minimum Equalized Pressure	
@ 70°F	49PSIG
@ 90°F	56PSIG
Refrigerant R134a.....	6.5 oz
Compressor.....	950BTU/hr

1-6 INSTALLATION

For proper air circulation, best cooling and energy consumption results, maintain a minimum distance of 2 inches (5.08cm) from adjacent items and surfaces.

CLEARANCE

AT TOP.....	2 in
AT SIDES.....	2 in
AT REAR.....	2 in

1-7 AIR FLOW

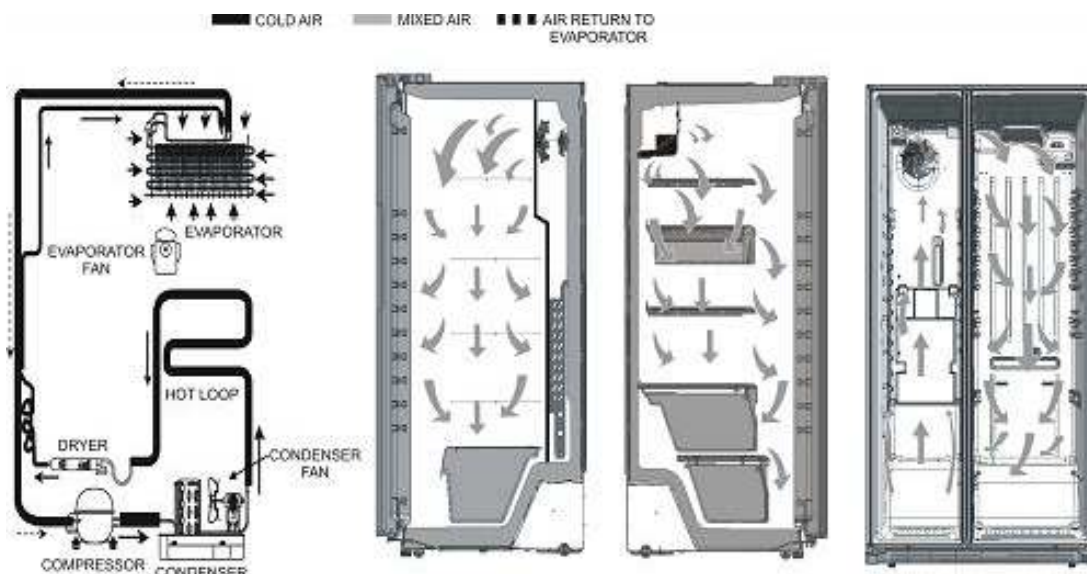

2. PARTS IDENTIFICATION

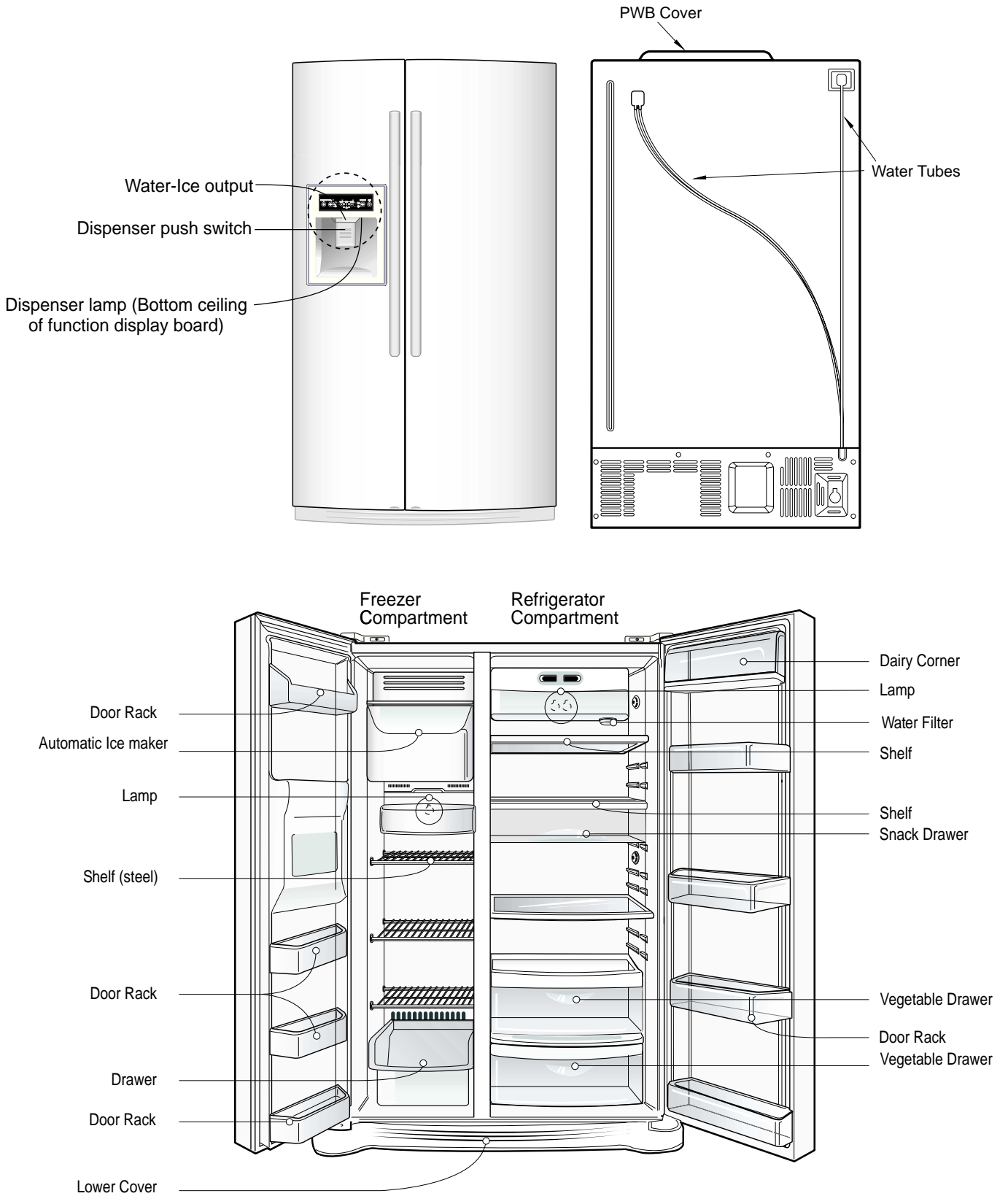

3. HOW TO INSTALL THE REFRIGERATOR

1. How to adjust the Refrigerator Door Height

(First identify your screw type, it could vary)

Make the refrigerator level first. (If the refrigerator is not installed on a flat floor, the height of freezer and refrigerator door may not be the same)

1) If the freezer door is lower than the refrigerator door:

2) If the freezer door is higher than the refrigerator door:
- Type 1

Make them level by inserting flat (- type) driver into the groove of the left height adjusting screw and rotating it clockwise (①)

Make them level by inserting flat (- type) driver into the groove of the right height adjusting screw and rotating it clockwise (①)

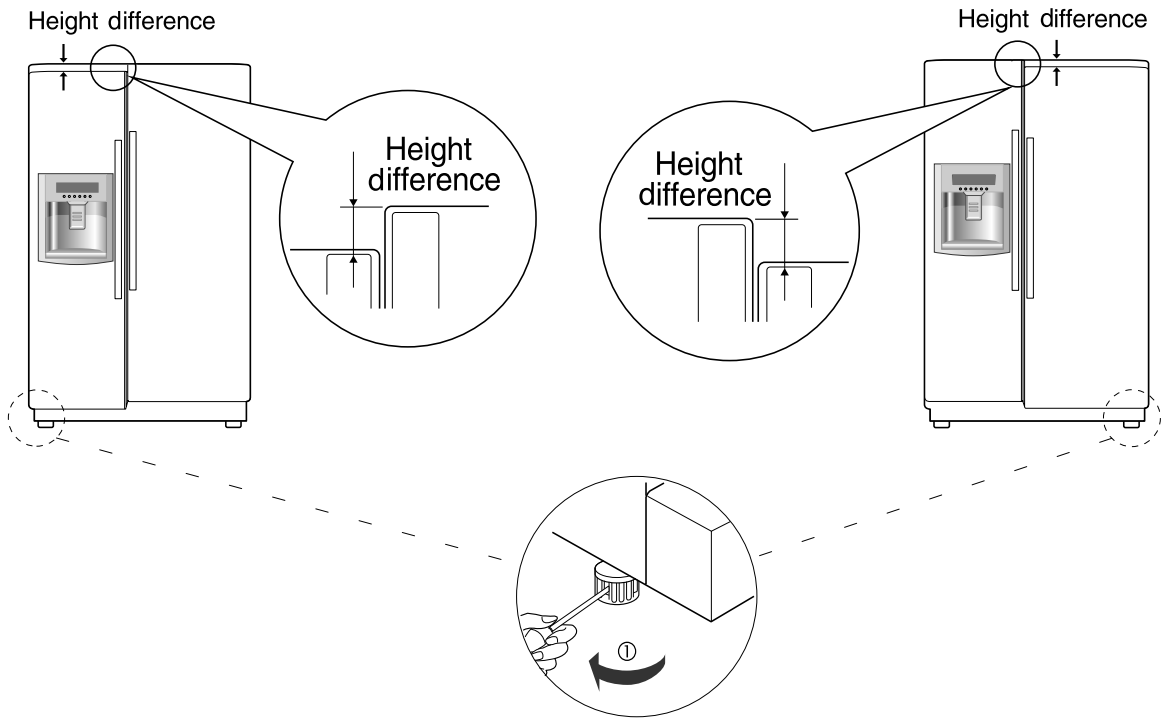

Adjust the level when the refrigerator door is lower than the freezer door during the use of the refrigerator.

1. Using the narrow side of the tool for adjustment, turn the adjustment hinge pin 2 (↻) clockwise or (↺) counterclockwise to level the refrigerator and freezer door.
2. After setting the level of the door, turn the keeper nut Counterclockwise to tighten.

Do not force too hard to level the height. The hinge pin can be pulled out. (Adjustable range of height is a maximum of 1/2"(1,27cm)).

The refrigerator door will close smoothly by raising the front side by adjusting the height adjusting screw. If the door does not close properly because it is improperly adjusted, the performance of the refrigerator will be affected.

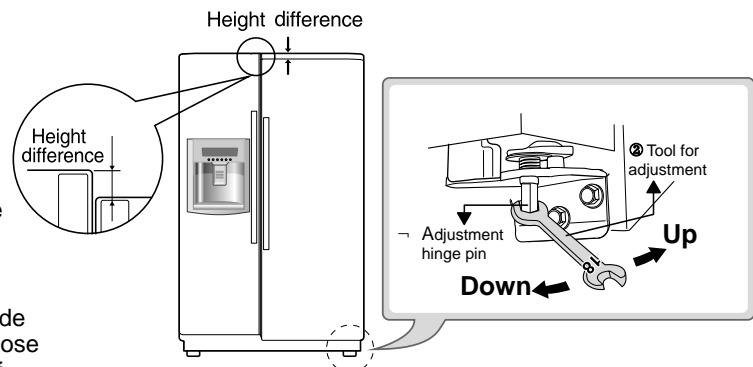

2. Install Water Filter (Applicable to some models only)

Before Installing Water Filter

1. Before installing the filter, take out the top shelf of the refrigerator after tilting it to the direction and lifting it to the direction and move it to the lower part.
2. Remove the lamp cover by pressing the protrusion under the cover and pulling the cover to the front.

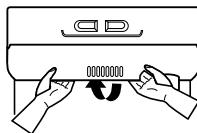
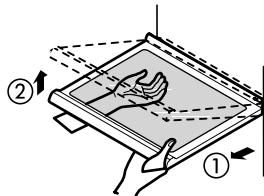

Installing water filter

1. Initial installation of water filter

Remove the filter substitute cap by turning it counterclockwise by 90 degrees and pulling it down.

Note: Keep the cap safe to use it later when you do not use the filter.

Remove the red cap from the filter and attach the sticker. Insert the upper part of the filter after aligning with the guideline marked on the control box, and fasten it by turning it clockwise by 90 degrees.

Note: Check that the guideline and the fastening indication line are aligned.

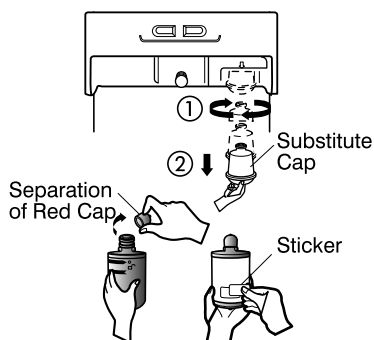

2. Replacement of water filter

While holding the lower part of the filter, turn it counterclockwise by 90 degrees and pull it down.

Note: Check that the guideline and the loosening indication line are aligned.

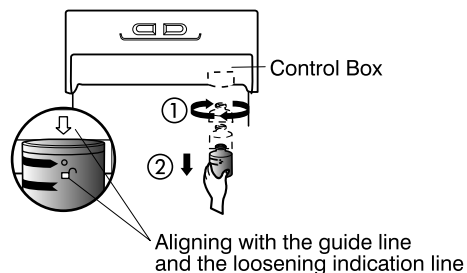
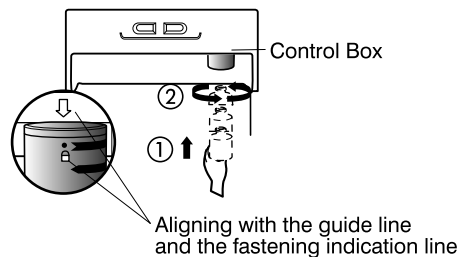

After installing water filter

Reassemble the lamp cover and the top shelf of the refrigerator. To place the top shelf of the refrigerator, raise the front part of the shelf a bit so that the hook of the shelf fits into the groove.

To purge the water filter system, let the water run for at least 3 minutes.

NOTE: Open the refrigerator and check for water droplets on the shelf under the filter.

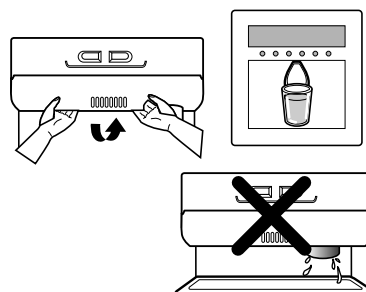

3. How to Control the Amount of Water Supplied to Icemaker.

3-1. Confirm the amount of water supplied to the icemaker.

1. Pull out the ice bin shelf in the upper part of the freezer compartment.

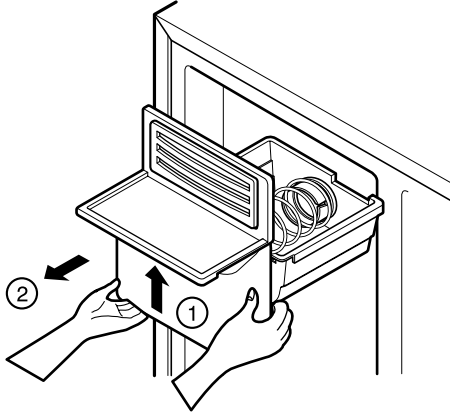

Caution: •Do not put hands or tools into the chute to confirm the operation of geared motor.
It may damage the refrigerator or hurt your hands.

2. Turn on the electricity after connecting water pipe.

- 1) Press the test switch under the icemaker for two seconds as shown below.
- 2) The bell rings (ding ~ dong), the ice tray rotates, and water comes out the icemaker water tube.
- 3) The water is supplied into the tray two or three times. The amount is small each time.
Put a container under the ice tray and press test switch.
- 4) When the ice tray rotates, the water in it will spill. Collect the spilled water and discard it.
- 5) When ice tray has finished rotation, water comes out the water tube. Check the amount that goes into the ice tray. (Refer to the drawing below. The optimum amount is 110cc. (Almost 4 oz.)).

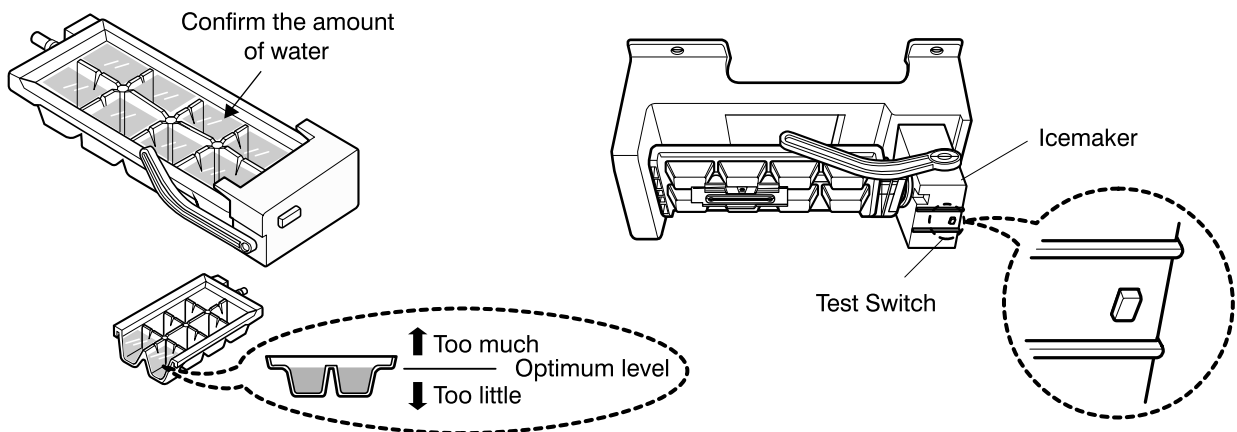

* It is acceptable if the adjusted water level is less than the optimum level.

3-2 Control the amount of water supplied to the icemaker.

Caution: • Unplug the power cord from the wall outlet and wait at least three minutes before removing the main PWB cover. 310 Volts are present in the control panel.

1. Disconnect PWB cover from the upper part of the refrigerator.
2. Adjust the amount of water supplied by using the DIP switches.

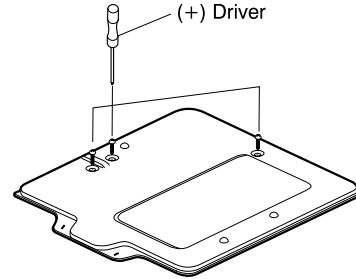

Water Supplying Time Control Option

LSC27910** (Refer to appendix)			
No	DIP SWITCH SETTING		Water Supply Time
	S1	S2	
1	OFF	OFF	6.5SEC
2	ON	OFF	5.5SEC
3	OFF	ON	7.5SEC
4	ON	ON	8.5SEC
5			
6			
7			
8			

- 1) The water supplying time is set at five seconds when the refrigerator is delivered.
- 2) The amount of water supplied depends on the setting time and water pressure (city water pressure).
- 3) If the ice cubes are too small, increase the water supplying time. This happens when too little water is supplied **into the ice tray**.
- 4) If the ice cubes stick together, decrease the water supplying time. This happens when too much water is supplied **into the ice tray**.

Caution: When adjusting the amount of water supplied, adjust step by step. Otherwise the water may spill over.

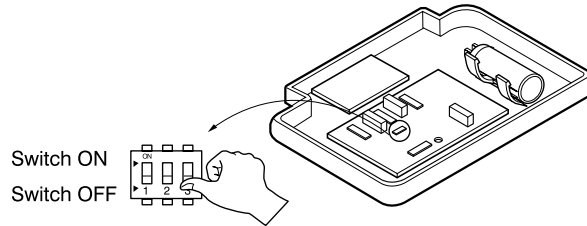

3. When the adjustment of the control switch for the amount of water supplied is complete, check the level of water in the ice.

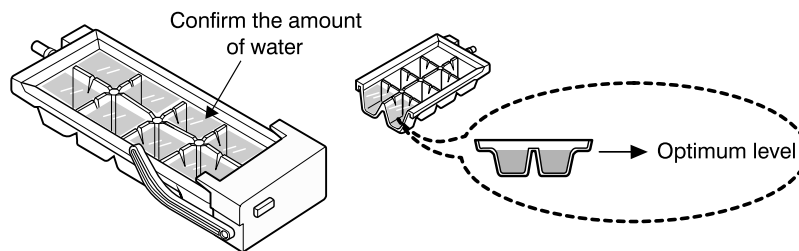

4. MICOM FUNCTION

1. Monitor Panel

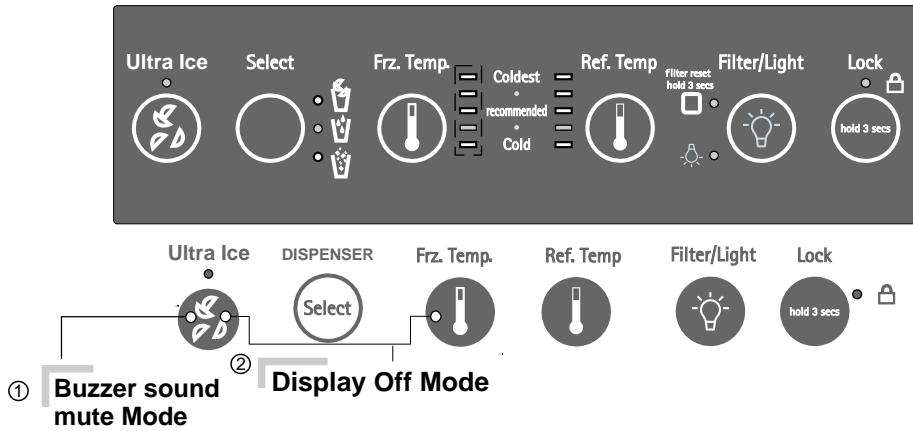

1-1. Display Second Function

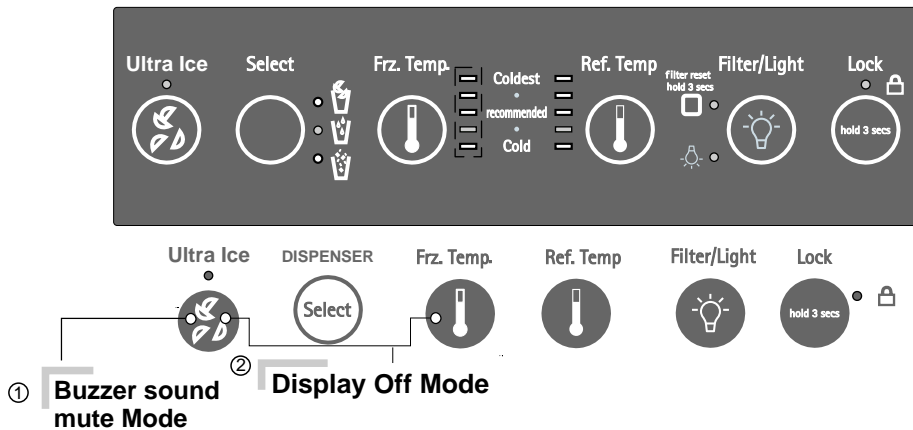

1. Buzzer sound mute Mode

The buzzer sound is set to OFF. It activates by sounding the recognition sound of “Ding ~” after pressing and holding ULTRA ICE” button more than 5 seconds. It inactivates when resetting the mode power.

















2. Display OFF mode.

Display off mode puts the display into standby mode until the door is opened.

To put the display into Display off Mode, press and holds the FRZ. TEMP. And ULTRA ICE buttons simultaneously for 5 seconds until the Ding~sounds. (Use both buttons for this to work.) When Display off Mode is activated, the display remains OFF unless a door is opened or a button is pressed. The display will return to the OFF position after 20 seconds inactivity. To remove the display from Display off Mode, press and hold the FREEZER and ULTRA ICE buttons simultaneously for 5 seconds until the Ding~sounds. The Display off Mode default setting is OFF after a power interruption.

2. Description of Function

2-1 Function of Temperature Selection

Division	Base	1st Press	2nd Press	3rd Press	4th Press
Setting temperature	5 4 3  2  1 	5 4  3  2  1 	5  4  3  2  1 	5 4 3 2  1 	5 4 3 2  1 
Temperature Control	Medium	Medium High	High	Low	Medium Low
Freezer Control	-2°F	-5°F	-8°F	7°F	1°F
Refrigeration Control	37°F	34°F	32°F	46°F	41°F

* The temperature can vary ± 3 C (26.6 °F ~ 37.4 °F) depending on the load condition.

❖ Press the button to cycle through the settings in this order: (Medium) → (Medium High) → (High) → (Low) → (Medium Low).

- The temperature displayed is the SET temperature, NOT the actual temperature inside the refrigerator. The actual temperature varies, depending upon the temperature of items put into the refrigerator and other variables.
- It takes the refrigerator a while to get down to the set temperature from the initial power-on. Wait at least 24 hours after initial power-up to put food into the refrigerator. If the temperature is unsatisfactory, adjust it and wait 24 hours. It may take three or four days to get the adjustment to your satisfaction.
- The freezer is automatically set to MEDIUM HIGH if the icemaker is set to ON.

2-2. Lock Function (dispenser and display button lock)

1. When the refrigerator is first turned on, the button are not locked. The lock indicator light is turn OFF.
2. To lock the display, the dispenser, and the control panel, press and hold the LOCK button for 3 seconds. The lock indicator light is turn ONN.
3. The LOCK button is the only control feature taht remains active in the locked state. The buzzer sound, other control buttons the dispenser are deactivated.
4. To release from the locked state, press and hold the LOCK button again for 3 seconds.



2-3. Filter condition display function

1. There is a replacement indicator light for the filter cartridge on the dispenser.
2. Water filter needs replacement at six months of water filter usage.
3. Filter Reset icon turn on to tell you need to replace the filter soon.
4. After replacing the filter, press and hold the FILTER/LIGHT button more than 3 seconds. Filter Reset icon turn off with reset status.



2-4 Dispenser use selection

1. You can select Water, Cubed Ice or Crushed Ice by pressing the SELECT button until reach the option desired.
2. A LED indicator will be turned on to show you the option selected.
3. To dispenser the option selected, use your cup to press the dispenser switch.
4. You will hear a CLICK when the Ice door closed 5 seconds after ice is dispensed.

REFERENCE: Hold your cup in the dispenser for a few seconds after Ice or Water to catch the last few drops or ice pieces.

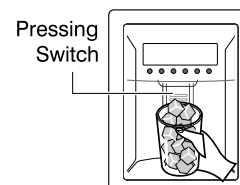
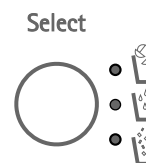

2-5 Ultra Ice selection

Please select this function for quick freezing.

- Function is repeat Ultra Ice Icon whenever pressing Ultra Ice button.
- Ultra Ice function automatically turns off after a fixed time passes.



2-6 Dispenser Light

Please select this function for DISPENSER LIGHT MODE.

1. Normal status (LIGHT icon is OFF): When dispenser is operated, DISPENSER LIGHT is ON.
2. ON status (LIGHT icon is ON): DISPENSER LIGHT is on continuously.
3. If DISPENSER LIGHT is turned ON for more that 7 minutes, this will be turned OFF automatically.



2-7 Ultra Ice

1. The purpose of this function is to intensify the cooling speed of freezer and to increase the amount of ice.
2. Whenever selection switch is pressed, selection/release, the LED will turn ON or OFF.
3. If there is a power outage and the refrigerator is powered on again, Ultra Ice will be canceled.
4. To activate this function, press the Ultra Ice key and the LED will turn ON. This function will remain activated for 24 hrs. The first three hours the compressor and Freezer Fan will be ON. The next 21 hours the freezer will be controlled at the lowest temperature. After 24 hours or if the Ultra Ice key is pressed again, the freezer will return to its previous Temperature.
5. During the first 3 hours:
 - (1) Compressor and freezer fan (HIGH RPM) run continuously.
 - (2) If a defrost cycle begins during the first 90 minutes of Ultra Ice, the Ultra Ice cycle will complete its cycle after defrosting has ended.
If the defrost cycle begins when Ultra Ice has run for more than 90 minutes, Ultra Ice will run for two hours after the defrost is completed.
 - (3) If Ultra Ice is pressed during defrost, Ultra Ice LED is on but this function will start seven minutes after defrost is completed and it shall operate for three hours.
 - (4) If Ultra Ice is selected within seven minutes after compressor has stopped, the compressor (compressor delays seven minutes) shall start after the balance of the delay time.
 - (5) The fan motor in the freezer compartment runs at high speed during Ultra Ice.
6. For the rest of the 21 hours, the freezer will be controlled at the lowest temperature.

2-6 Control of variable type of freezing fan

1. To increase cooling speed and load response speed, MICOM variably controls freezing room fan motor at the high speed of RPM and standard RPM.
2. MICOM only operates in the input of initial power or express freezing operation or load response operation for the high speed of RPM and operates in the standard RPM in the other general operation.
3. If opening doors of freezing / cold storage room while fan motor in the freezing room operates, the freezing room fan motor normally operates (if being operated in the high speed of RPM, it converts operation to the standard ROM). However, if opening doors of freezing room of freezing room, the freezing room fan motor stops.
4. As for monitoring of BLDC fan motor error in the freezing room, MICOM immediately stops the fan motor by determining that the BLDC fan motor is locked or fails if there would position signal for more than 115 seconds at the BLDC motor. Then it displays failure (refer to failure diagnosis function table) at the display part of refrigerator, the BLDC motor doesn't operate more. If you want to operate the BLDC motor, turn off and on power resource.

2-7 Control of cooling fan motor

1. The cooling fan motor performs ON/OFF control by linking with the COMP.
2. It controls at the single RPM without varying RPM.
3. Failure sensing method is same as in fan motor of freezing fan motor (refer to failure diagnosis function table for failure display).

2-8. Door opening alarm

1. Buzzer generates alarm sounds if doors are not closed even when more than a minute consecutively has passed with doors of freezer / refrigerator opened.
2. After the door has been open for one minute, the buzzer sounds for ½ second and then sounds three times every 30 seconds.
3. If all doors are closed when the alarm sounds, it is cancelled immediately.

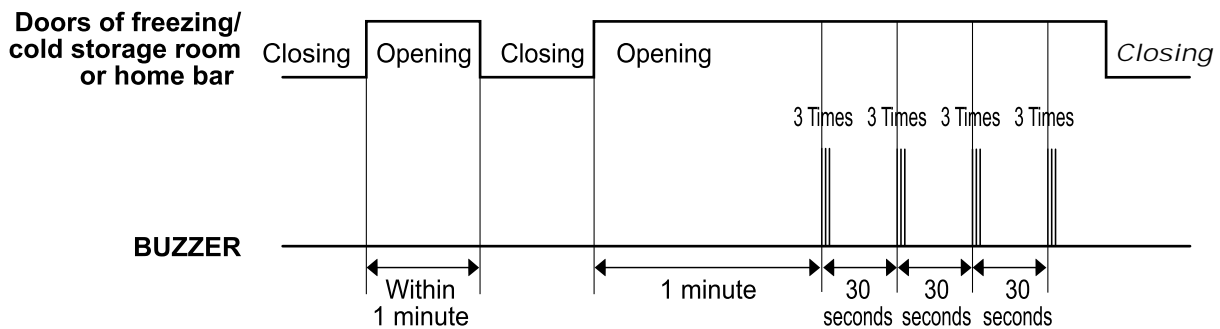

2-9. Ringing of button selection buzzer

1. The ding ~ will sound whenever a button is pressed.

2-10. Ringing of compulsory operation, compulsory frost removal buzzer

1. If pressing the test button in the Main PCB, a beep will sound.
2. In selecting compulsory operation, alarm sound is repeated and completed in the cycle of On for 2/10 second and Off for 1 8/10 second three times.
3. On selecting compulsory frost removal, alarm sound is repeated and completed in the cycle of On 2/10 second, Off for 2/10 second, On for 2/10 second and Off for 1 4/10 second three times.

2-11 Defrost function

1. Defrost is performed whenever total operation time of compressor becomes 7-50 hour.
2. In providing initial power (or returning failure), frost removal starts whenever total operation time of compressor becomes 4-5 hours.
3. Defrost is completed if temperature of a defrost sensor becomes more than 5°C after starting defrost. The defrost cycle will fail if the refrigerator does not reach a temperature of 5°C (9°F) two hours into the defrost cycle.
4. The defrost cycle will not operate if the defrost sensor fails, arcs or shorts cut.

2.12 Refrigerator lamp automatically off

Refrigerator lamp turns on and off by refrigerator door switch.

If refrigerator lamp continuously turns on more than 7 minutes, the refrigerator room turns off automatically period.

2-13 Sequential operation of built-in product

Built-in products such as compressor, frost removal heater, freezing room fan, cooling fan and step motor damper are operated sequentially as follows to prevent noise and part damage due to simultaneous operation of several parts in applying initial power and completing test.

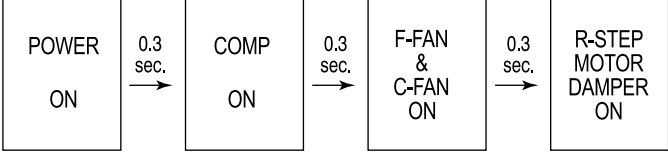
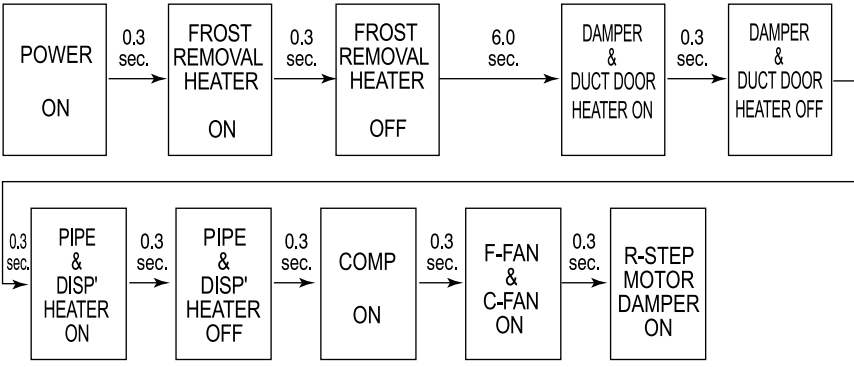
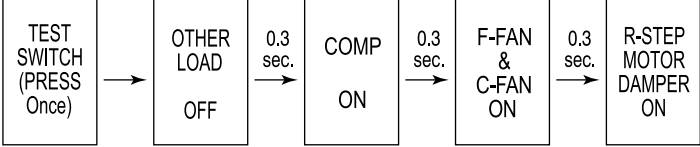
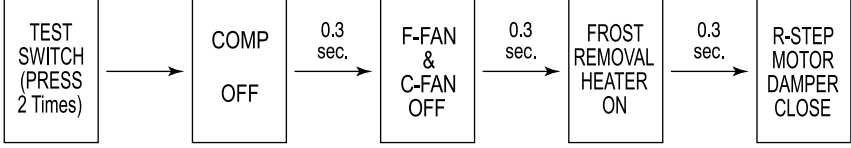
Function	Load Operation Sequence	Remark
In applying Initial power	<p>When temperature of a frost removal sensor becomes more than 45° c (113°F) (In purchase, movement)</p> 	<p>If error occurs during operation, initial operation is not done.</p> <p>□ Sequence of load operation when closing Freezer and Refrigerator.</p>
	<p>When temperature of a frost removal sensor becomes less than 45° C (113° F) (In power failure, service)</p> 	
TEST MODE	<p>Test mode 1 (Compulsory function)</p> 	<p>If pressing switch once more in the test mode 2 or temperature of a frost removal sensor is more than 45 C (113 F), it immediately returns to the test mode for initial operation (COMP operates after 7 minutes).</p>
	<p>Test mode 2 (Compulsory frost removal)</p> 	

2-14 Failure Diagnosis Function

- When an error occurs, the buttons will not operate; but the tones still sound.
- After the repair is made, it is necessary to replug in the refrigerator to reset to normal operation.

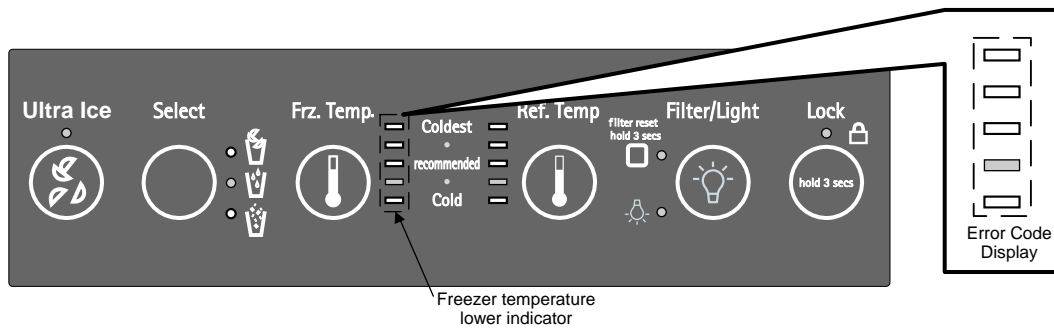

ERROR CODES displayed on Frz. Temp. indicator lights.

ITEM	ERROR CODE	POSSIBLES CAUSES	PRODUCT OPERATION STATUS IN FAILURE				
			COMPRESSOR	FREEZING BLDC MOTOR	COOLING BLDC MOTOR	DEFROST HEATER	STEPPING MOTOR DAMPER
FREEZER SENSOR	<div style="display: flex; flex-direction: column; align-items: center;"> <div style="width: 10px; height: 10px; border: 1px solid black; margin-bottom: 2px;"></div> <div style="width: 10px; height: 10px; border: 1px solid black; margin-bottom: 2px;"></div> <div style="width: 10px; height: 10px; border: 1px solid black; margin-bottom: 2px;"></div> <div style="width: 10px; height: 10px; background-color: black; margin-bottom: 2px;"></div> <div style="width: 10px; height: 10px; border: 1px solid black;"></div> </div>	FREEZER SENSOR OPEN / SHORT CIRCUIT	ON FOR 15MIN/ OFF FOR 15MIN	STANDARD RPM	NORMAL OPERATION	NORMAL OPERATION	NORMAL OPERATION
REFRIGERATOR SENSOR (R1) (UPPER PART IN THE REFRIGERATOR COMPARTMENT)	<div style="display: flex; flex-direction: column; align-items: center;"> <div style="width: 10px; height: 10px; border: 1px solid black; margin-bottom: 2px;"></div> <div style="width: 10px; height: 10px; border: 1px solid black; margin-bottom: 2px;"></div> <div style="width: 10px; height: 10px; background-color: black; margin-bottom: 2px;"></div> <div style="width: 10px; height: 10px; border: 1px solid black; margin-bottom: 2px;"></div> <div style="width: 10px; height: 10px; border: 1px solid black;"></div> </div>	REFRIGERATOR SENSOR (R1) OPEN/ SHORT CIRCUIT	NORMAL OPERATION	STANDARD RPM	NORMAL OPERATION	NORMAL OPERATION	FULL OPENING FOR 10 MIN / FULL CLOSING FOR 15 MIN
DEFROST SENSOR	<div style="display: flex; flex-direction: column; align-items: center;"> <div style="width: 10px; height: 10px; border: 1px solid black; margin-bottom: 2px;"></div> <div style="width: 10px; height: 10px; background-color: black; margin-bottom: 2px;"></div> <div style="width: 10px; height: 10px; border: 1px solid black; margin-bottom: 2px;"></div> <div style="width: 10px; height: 10px; border: 1px solid black; margin-bottom: 2px;"></div> <div style="width: 10px; height: 10px; border: 1px solid black;"></div> </div>	DEFROST SENSOR OPEN/ SHORT CIRCUIT	NORMAL OPERATION	STANDARD RPM	NORMAL OPERATION	NO DEFROST	NORMAL OPERATION
FAILED DEFROST COMPONENT	<div style="display: flex; flex-direction: column; align-items: center;"> <div style="width: 10px; height: 10px; background-color: black; margin-bottom: 2px;"></div> <div style="width: 10px; height: 10px; background-color: black; margin-bottom: 2px;"></div> <div style="width: 10px; height: 10px; background-color: black; margin-bottom: 2px;"></div> <div style="width: 10px; height: 10px; background-color: black; margin-bottom: 2px;"></div> <div style="width: 10px; height: 10px; border: 1px solid black;"></div> </div>	DEFROST HEATER, TEMPERATURE FUSE OPEN, UNPLUGGED CONNECTOR	NORMAL OPERATION	STANDARD RPM	NORMAL OPERATION	NORMAL OPERATION	NORMAL OPERATION
EVAPORATOR BLDC MOTOR	<div style="display: flex; flex-direction: column; align-items: center;"> <div style="width: 10px; height: 10px; background-color: black; margin-bottom: 2px;"></div> <div style="width: 10px; height: 10px; border: 1px solid black; margin-bottom: 2px;"></div> <div style="width: 10px; height: 10px; border: 1px solid black; margin-bottom: 2px;"></div> <div style="width: 10px; height: 10px; background-color: black; margin-bottom: 2px;"></div> <div style="width: 10px; height: 10px; border: 1px solid black;"></div> </div>	MOTOR DEFECTIVE, FAN BLADE OBSTRUCTED, SHORT / OPEN WIRE OF FAN MOTOR.	NORMAL OPERATION	OFF	NORMAL OPERATION	NORMAL OPERATION	NORMAL OPERATION
CONDENSER BLDC MOTOR	<div style="display: flex; flex-direction: column; align-items: center;"> <div style="width: 10px; height: 10px; border: 1px solid black; margin-bottom: 2px;"></div> <div style="width: 10px; height: 10px; border: 1px solid black; margin-bottom: 2px;"></div> <div style="width: 10px; height: 10px; background-color: black; margin-bottom: 2px;"></div> <div style="width: 10px; height: 10px; background-color: black; margin-bottom: 2px;"></div> <div style="width: 10px; height: 10px; border: 1px solid black;"></div> </div>	MOTOR DEFECTIVE, FAN BLADE OBSTRUCTED, SHORT / OPEN WIRE OF FAN MOTOR.	NORMAL OPERATION	NORMAL OPERATION	OFF	NORMAL OPERATION	NORMAL OPERATION
AMBIENT SENSOR	NORMAL DISPLAY (NOTE 1)	AMBIENT SENSOR SHORT / OPEN CIRCUIT	NORMAL OPERATION	NORMAL OPERATION	NORMAL OPERATION	NORMAL OPERATION	NORMAL OPERATION
ICE-MAKER SENSOR	NORMAL DISPLAY (NOTE 1)	ICE-MAKER SENSOR SHORT / OPEN CIRCUIT	NORMAL OPERATION	NORMAL OPERATION	NORMAL OPERATION	NORMAL OPERATION	NORMAL OPERATION
ICE-MAKER UNIT	NORMAL DISPLAY (NOTE 1)	FAULTY ICE-MAKER UNIT MOTOR OR HALL IC, LEAD WIRE SHORT CIRCUIT, FAULTY MOTOR DRIVING CIRCUIT	NORMAL OPERATION	NORMAL OPERATION	NORMAL OPERATION	NORMAL OPERATION	NORMAL OPERATION
WATER TEMPERATURE SENSOR	NORMAL DISPLAY (NOTE 1)	WATER TANK SENSOR SHORT / OPEN CIRCUIT	NORMAL OPERATION	NORMAL OPERATION	NORMAL OPERATION	NORMAL OPERATION	NORMAL OPERATION
REFRIGERATOR SENSOR (R2) (LOWER PART IN THE REFRIGERATOR COMPARTMENT)	NORMAL DISPLAY (NOTE 1)	REFRIGERATOR SENSOR (R2) SHORT / OPEN CIRCUIT	NORMAL OPERATION	STANDARD RPM	NORMAL OPERATION	NORMAL OPERATION	NORMAL OPERATION

By pressing and holding freezer temperature adjust button and ultra ice button all leds on the control board will light on.
Note 1: The below items will not display in error code, to check this items press and hold freezer temperature adjust button and Ultra ice button for at least one second.

- R2-SENSOR (LOWER SENSOR IN REFRIGERATOR COMPARTMENT).....DEFFECTIVE: "ULTRA ICE" INDICATOR WILL NOT BE LIT
- WATER TANK SENSOR.....DEFFECTIVE: "LOCK" INDICATOR WILL NOT BE LIT
- ICE-MAKER SENSOR.....DEFFECTIVE: "CUBE ICE" INDICATOR WILL NOT BE LIT
- ICE-MAKER ASSEMBLY.....DEFFECTIVE: "CRUSH ICE" INDICATOR WILL NOT BE LIT
- AMBIENT SENSOR.....DEFFECTIVE: "FREEZER TEMPERATURE LOWER" INDICATOR WILL NOT BE LIT (SEE FIG. 1)

2-15 Test Function

1. The purpose of test function is to check function of the PWB and product and to search for the failure part at the failure status.
2. Test button is placed on the main PCB of refrigerator (test switch), and the test mode will be finished after maximum 2 hours regardless of test mode and then is reset to the normal status.
3. In finishing test mode, always pull the power cord out and then plug-in it again for the normal state.
 Always wait at least 3 minutes before restarting a compressor to allow the pressures to equalize and to avoid damage.
4. If nonconforming contents such as sensor failure are found during performance of test mode, release the test mode and display the failure code.

Mode	Operation	Function	Remarks
Test 1	Press test button once	<ul style="list-style-type: none"> • Compressor on, Evaporator BLDC motor on and Condenser BLDC motor on. • Damper is completely opened. • All display LEDs Graphics turns on. 	Evaporator fan turns off if the door are open.
Test 2	Press the button again, to enter to Test 2.	<ul style="list-style-type: none"> • Compressor off, Evaporator BLDC motor off and Condenser BLDC motor off. • Defrost heater turn on. • Damper is completely closed. • All LEDS will be off except the lower three refrigerator and freezer temperature indicator lights. 	Return to the normal mode when the defrost sensor is above +41°F (5°C)
Normal Status	Press the button again, to return to Normal status.	Normal operation	Compressor will operate after delay for 7 minutes

NOTE: Test mode will not begin if an error code is displayed.

NOTE: During the Test mode, display board buttons will not operate.

After finishing the Test mode, always unplug and replugin in the refrigerator to reset to normal operation.

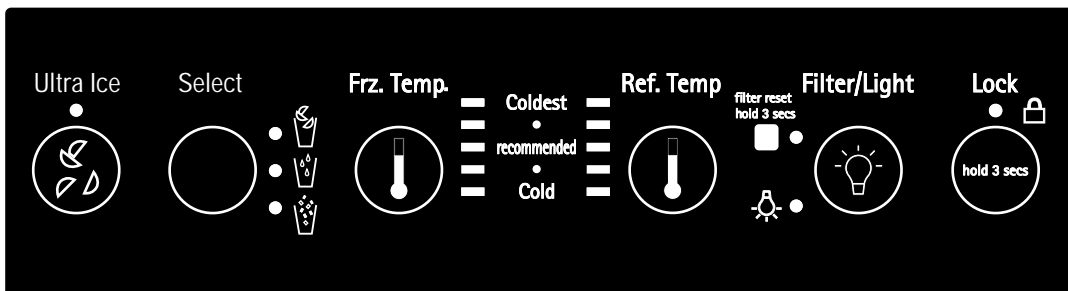
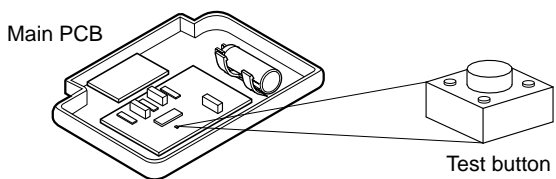

2-16. Function of dispenser and water dispenser built-in

1. The dispenser allows ice and water to be served without opening the freezer door.
2. Press the dispenser switch (the rubber button) after selecting crushed ice, cubed ice or water. The dispenser door will open automatically. It will close automatically 5 seconds after dispensing is completed, and you will hear the CLICK.
3. The dispenser will not operate when the freezer door is open.
4. The ice dispenser will automatically stop after 3 minutes even without an OFF signal. The ice door will close automatically 5 seconds after that, and you will hear the CLICK.
5. Dispenser Lamp ON/OFF function.
The dispenser lamp is operated in conjunction with the dispenser switch. It comes on when ice or water is dispensed, and turn off when dispensing is completed.
6. Selection function of water/crushed/cube ice
 - 1) This allows the selection of water/cubed/crushed ice. Press the button to cycle through WATER → CRUSHED →CUBED.
 - 2) At initial power-on, the dispenser defaults to CUBED ICE.
 - 3) When CUBE ICE is selected, the geared motor rotates, and the Solenoid Cube is activated, so CUBE ICE is dispensed.
 - 4) When CRUSHED ICE is selected, the geared motor rotates, and the Solenoid Cube is deactivated, so CRUSHED ICE is dispensed.
7. Water dispenser function
 - 1) Select WATER to dispenser water.
 - 2) The water line is a direct connection to the household water supply. If water is selected at the dispenser, a solenoid opens and allows water to flow. A similar solenoid is operated in conjunction with the ice maker to fill it at the appropriate time in its cycle.

2-17. Demonstration MODE Sequence

1. Any Door must be opened to enter in this mode.
2. When the ULTRA ICE button and REF. TEMP button are pushed at the same time and hold for 5 seconds or longer, it converts to Demonstration Mode Sequence. You will hear a sound indicating Demo Mode Sequence is activated.
3. In Demo Mode Sequence, cooling system is disabled, only lamps and display works normally.
4. To disable Demo Mode Sequence, push ULTRA ICE button and REF. TEMP button at the same time and hold for 5 seconds or longer. You will hear a sound indicating Demo Mode Sequence is deactivated.

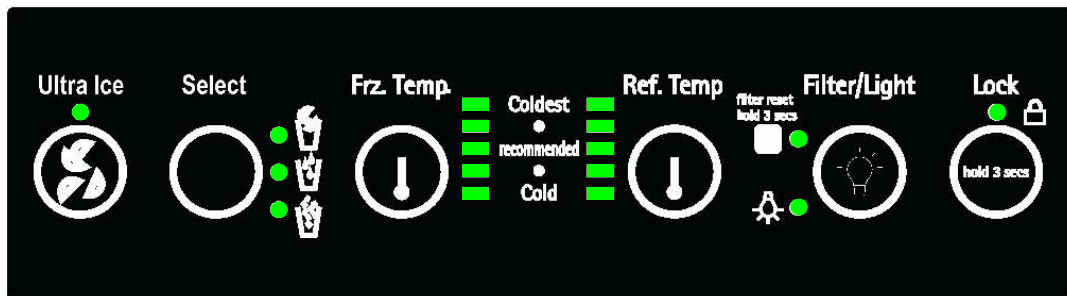

5. CIRCUIT

DELUXE

- H/BAR PART (H/BAR HEATER, DOOR S/W), CAPACITOR PART, FUSE PART, PLUG TYPE, COMPRESSOR EARTH PART, ICE & WATER VALVES, PILOT VALVE, S/W PART, OPTICILL ZONE, P.T.C ASSEMBLY, COMP' ACCESSORIES, WATER-TANK SENSOR ON CIRCUIT DIAGRAMS ARE SUBJECT TO CHANGE IN DIFFERENT LOCALITIES AND ACCORDANCE WITH MODEL TYPE.

- N: NEUTRAL

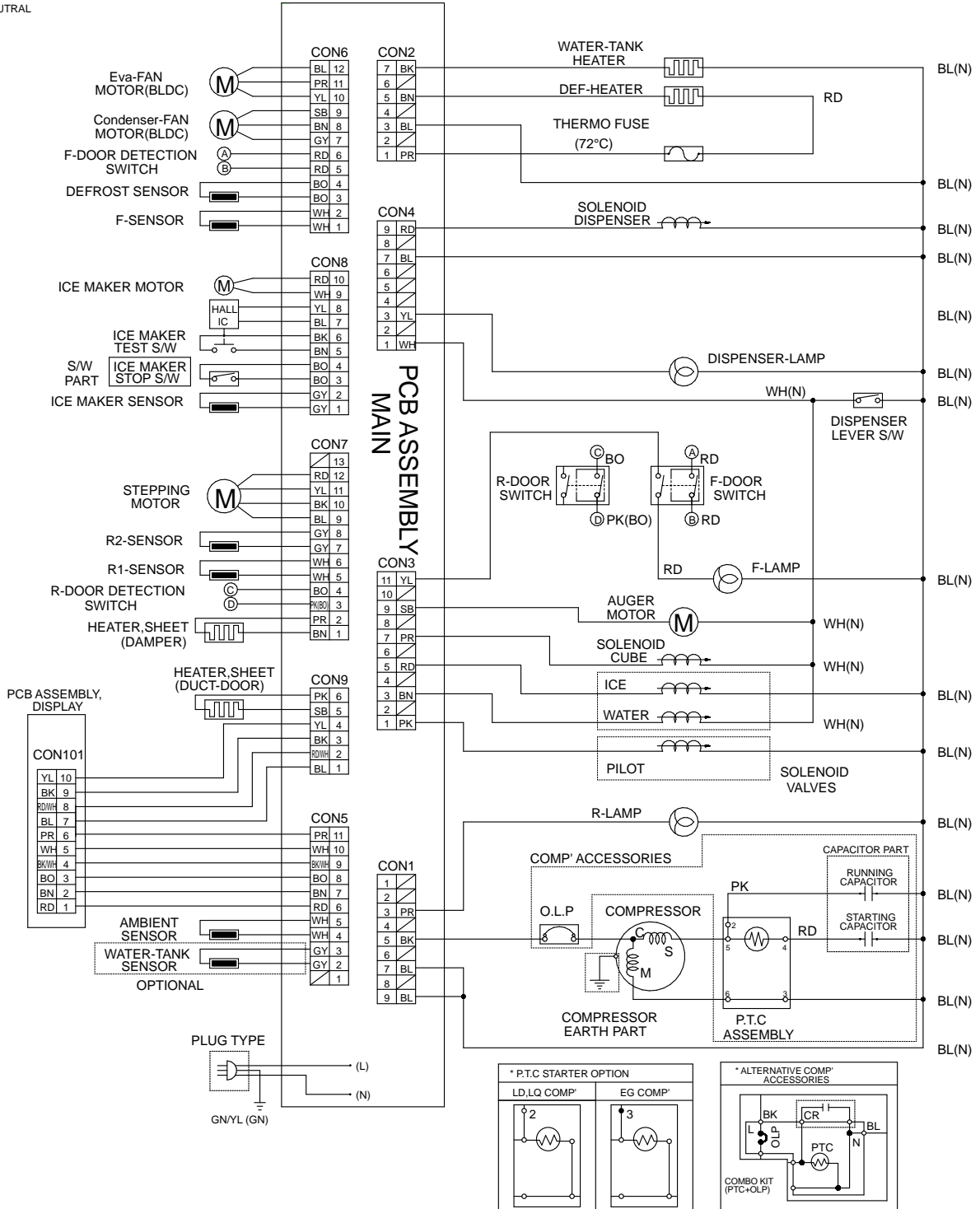

BK: BLACK
YL: YELLOW
SB: SKY BLUE
BN: BROWN

GN: GREEN
PK: PINK
BO: BRIGHT ORANGE
PR: PURPLE

GY: GRAY
WH: WHITE
BL: BLUE
RD: RED

GN/YL: GREEN/YELLOW
BL/WH: BLUE/WHITE
BK/WH: BLACK/WHITE
RD/WH: RED/WHITE

6. EXPLANATION FOR MICOM CIRCUIT

1. Explanation for PWB circuit

1-1 Power Circuit

The power circuit includes a Switched Mode Power Supply (SMPS). It consists of a rectifier (BD1 and CE1) converting AC to DC, a switch (IC2) switching the DC voltage, a transformer, and a feedback circuit (IC3 and IC4).

Caution : Since high voltage (160 Vdc) is maintained at the power terminal, wait at least 3 minutes after unplugging the appliance to check the voltages to allow the current to dissipate.

Voltage of every part is as follows:

Part	VA1	CE1	CE2	CE3	CE4	CE5
Voltage	120 Vac	160 Vdc	14 Vdc	12 Vdc	15.5 Vdc	5 Vdc

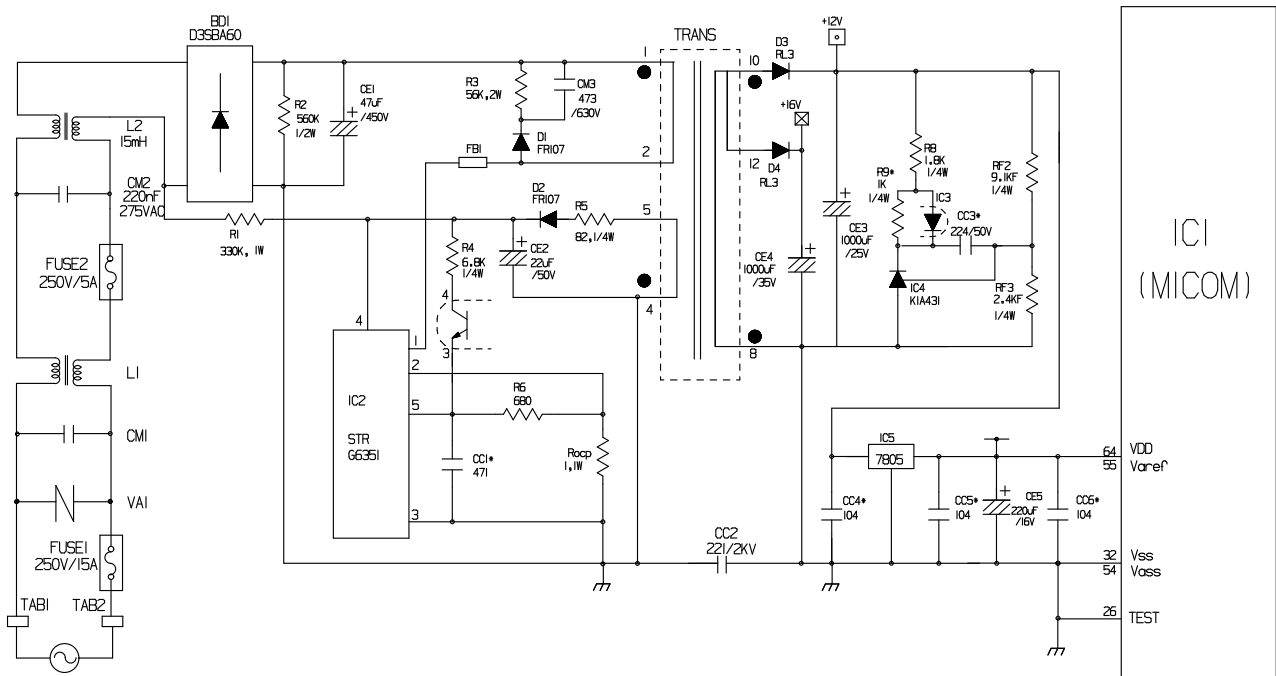

1-2 Main PCB Top View.

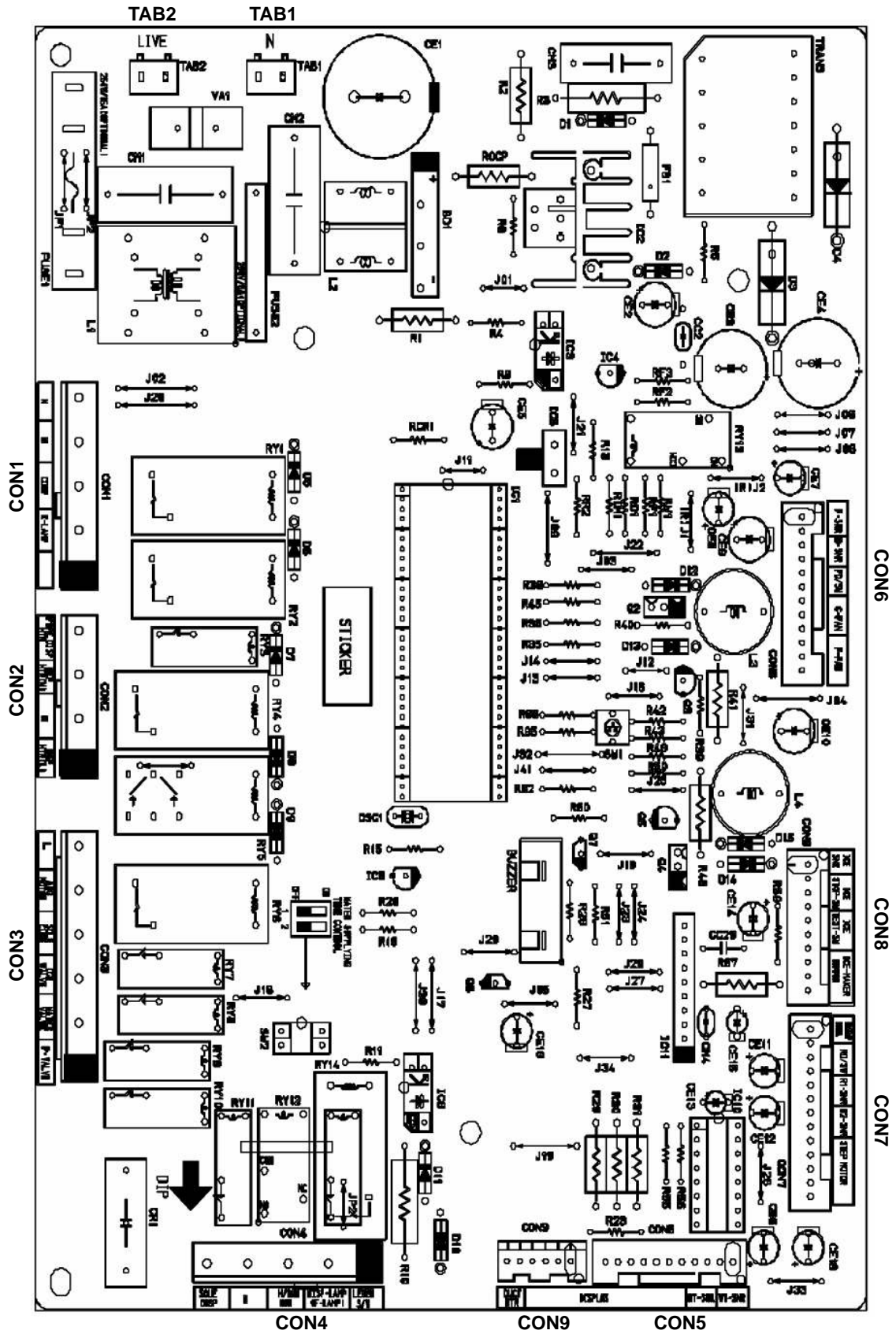

1-3 Load / Dispenser operation Circuit.

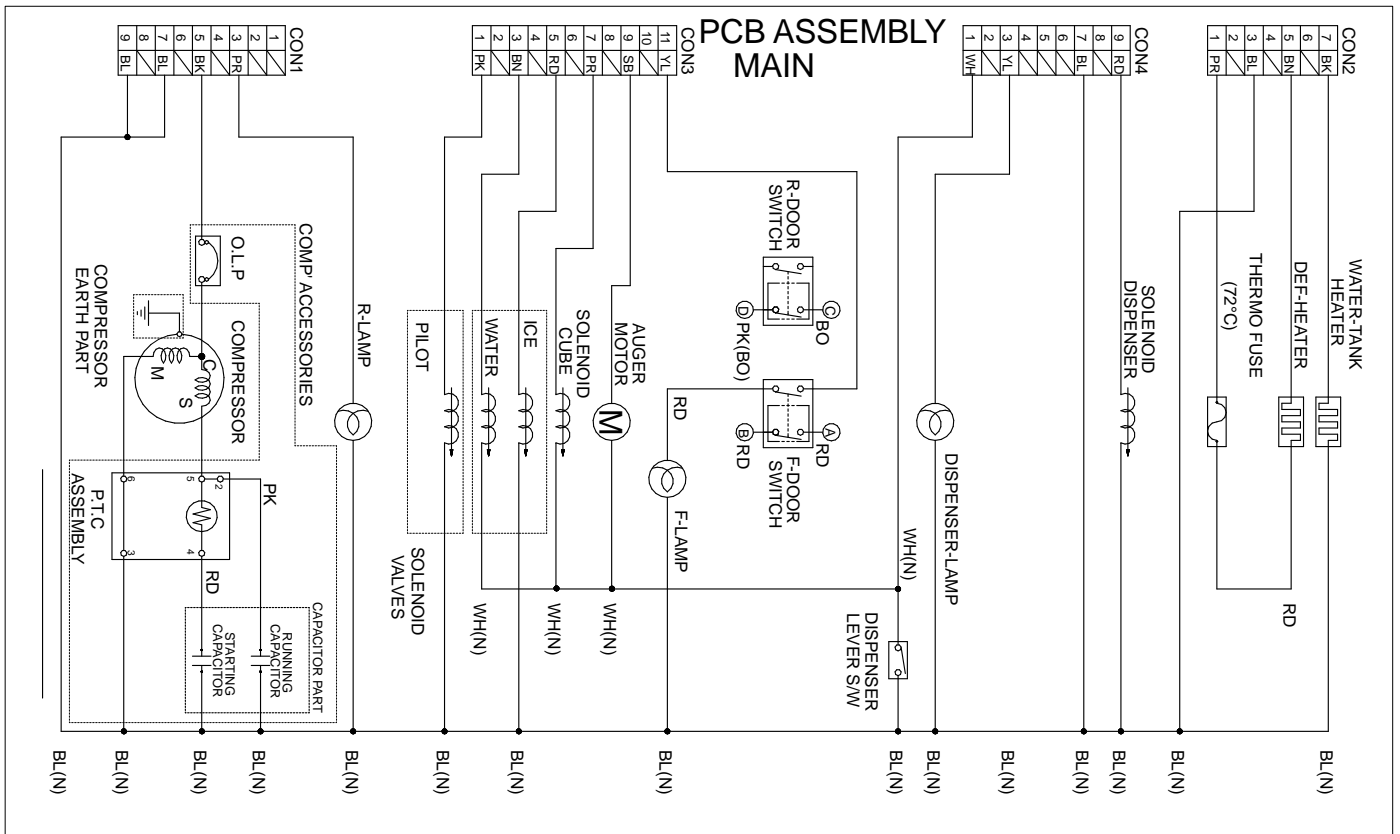

Type of Load	Compressor	Defrost Heater	Refrigerator Lamp	Dispenser Lamp	Water Tank Heater	Geared Motor	Solenoid Cube	Water Valve	Pilot Valve	Ice Valve	Solenoid Dispenser	
Measuring Part	A	CON1 PIN5	CON2 PIN1	CON1 PIN3	CON4 PIN3	CON2 PIN7	CON3 PIN9	CON3 PIN7	CON3 PIN3	CON3 PIN1	CON3 PIN5	CON4 PIN9
	B	CON1 PIN7	CON2 PIN5	CON1 PIN7	CON4 PIN7	CON2 PIN3	CON2 PIN3	CON2 PIN3	CON2 PIN3	CON2 PIN3	CON2 PIN3	CON4 PIN7
STATUS	ON	110-127 VAC	110-127 VAC	110-127 VAC	110-127 VAC	110-127 VAC	110-127 VAC	110-127 VAC	110-127 VAC	110-127 VAC	110-127 VAC	110-127 VAC
	OFF	0 VAC	0 VAC	0 VAC	0 VAC	0 VAC	0 VAC	0 VAC	0 VAC	0 VAC	0 VAC	0 VAC

1-4 Door opening Sensing Circuit.

MEASURING PART		OPENING	CLOSING
F-DOOR	A(RD)	0V	5V
	B(RD)		
R-DOOR	C(BO)	0V	5V
	D(BO or PK)		

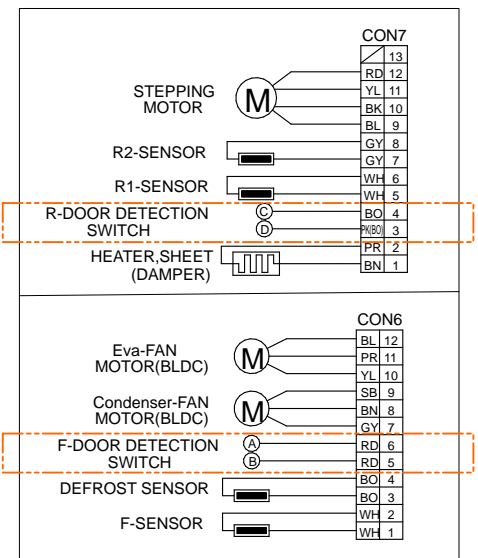

1-5 Temperature Sensing Circuit.

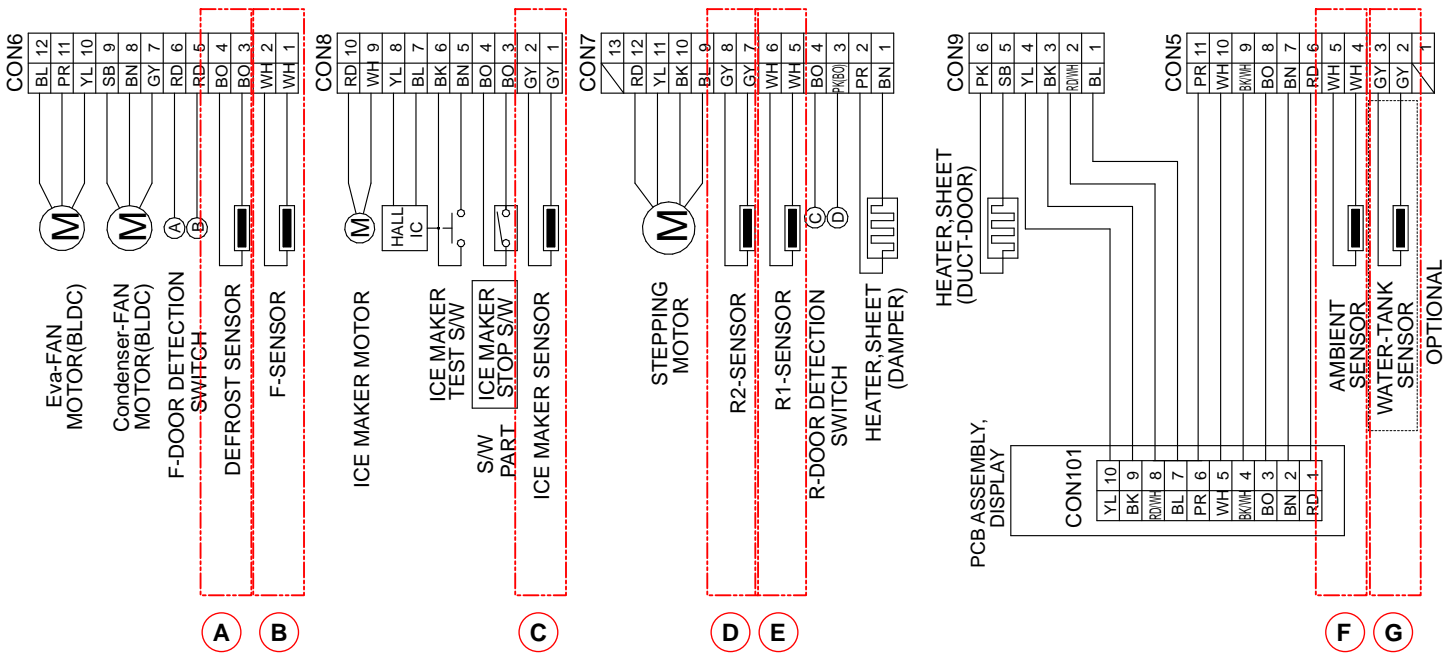

The circuits involving the freezer and refrigerator sensors control the temperature in both the freezer and the refrigerator. The icemaker sensor defects when ice is made. The defrost sensor determine both the need for defrosting and the efficiency of the defrost operation. See the table below for voltages and checkpoints.

ITEM	CHECKPOINT		SENSOR STATUS			WIRE	REMARK
	VOLTAGE	GND	NORMAL	SHORT	OPEN	COLOR	
A	CON7 PIN3	CON7 PIN4	0.5V~4.5V	0V	5V	BO*2	DEFROST SENSOR
B	CON7 PIN1	CON7 PIN2	0.5V~4.5V	0V	5V	WH*2	FREEZER SENSOR
C	CON8 PIN1	CON8 PIN2	0.5V~4.5V	0V	5V	GY*2	ICE MAKER SENSOR
D	CON7 PIN7	CON7 PIN8	0.5V~4.5V	0V	5V	GY*2	REFRIGERATOR SENSOR (2)
E	CON7 PIN5	CON7 PIN6	0.5V~4.5V	0V	5V	WH*2	REFRIGERATOR SENSOR
F	CON5 PIN4	CON5 PIN5	0.5V~4.5V	0V	5V	WH*2	AMBIENT SENSOR
G	CON5 PIN2	CON5 PIN1	0.5V~4.5V	0V	5V	GY*2	WATER TANK SENSOR

1-6 Switch entry circuit

The following circuits are sensing form the test switch, damper motor reed switch for testing and diagnosing the refrigerator.

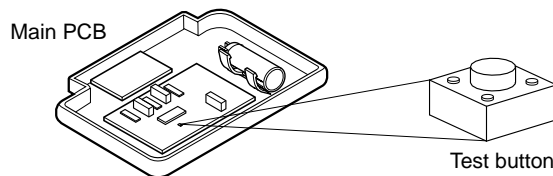

1-7 Stepping motor Circuit.

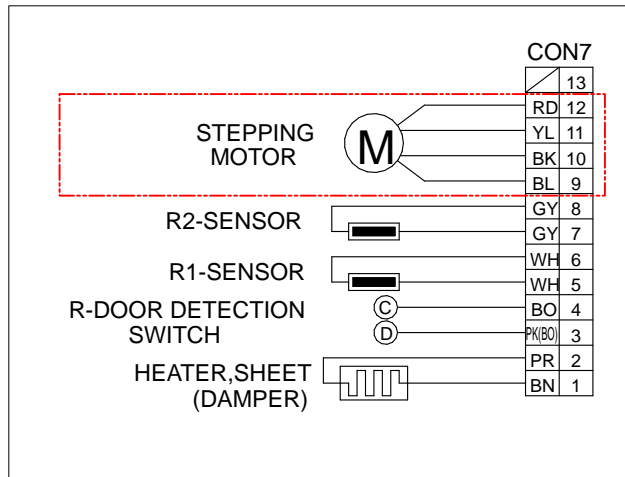

1-8 Fan Motor Driving Circuit.

1. This circuit changes the speed of the fan motor or stop, varying the DC voltage as shown in the next table.
2. The circuit stops any fan motor by cutting off power when lock-up condition is detected.

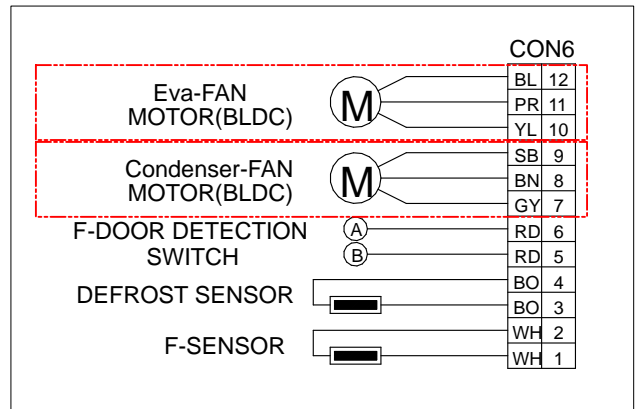



ITEM	CHECKPOINTS			REMARK	
	VOLTAGE	GND	LOOPBACK		
A	MOTOR ON	CON6 PIN12	CON6 PIN11	CON6 PIN10	EVAPORATOR MOTOR FAN
	MOTOR OFF	8~16V	2~3V	5V	
B	MOTOR ON	CON6 PIN7	CON6 PIN8	CON6 PIN9	CONDENSER MOTOR FAN
	MOTOR OFF	12~14V	2~3V	5V	

1-9 Temperature compensation and temperature compensation circuit.

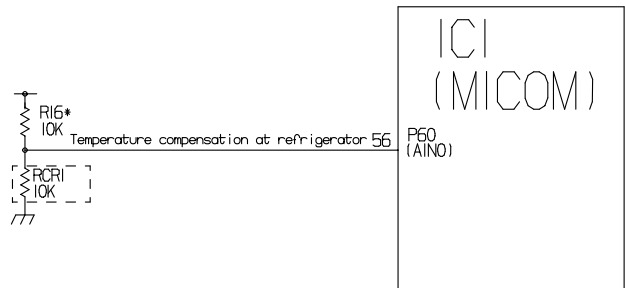
1. Temperature compensation in freezer and refrigerator.



Freezer		Refrigerator		Remarks
Resistance value (RCF1)	Temperature compensation	Resistance value (RCR1)	Temperature compensation	
180 kΩ	+5°C [+9 °F]	180 kΩ	+2.5°C [+4.5 °F]	Warmer 
56 kΩ	+4°C [+7.2°F]	56 kΩ	+2.0°C [+3.6 °F]	
33 kΩ	+3°C [+5.4°F]	33 kΩ	+1.5°C [+2.7 °F]	
18 kΩ	+2°C [+3.6°F]	18 kΩ	+1.0°C [+1.8 °F]	
12 kΩ	+1°C [+1.8°F]	12 kΩ	+0.5°C [+0.9 °F]	
10 kΩ	0 °C [0 °F]	10 kΩ	0 °C [0 °F]	Reference temperature
8.2 kΩ	-1 °C [-1.8 °F]	8.2 kΩ	-0.5 °C [-0.9 °F]	Cooler 
5.6 kΩ	-2 °C [-3.6 °F]	5.6 kΩ	-1.0 °C [-1.8 °F]	
3.3 kΩ	-3 °C [-5.4 °F]	3.3 kΩ	-1.5 °C [-2.7 °F]	
2 kΩ	-4 °C [-7.2 °F]	2 kΩ	-2.0 °C [-3.6 °F]	
470 Ω	-5 °C [-9 °F]	470 Ω	-2.5 °C [-4.5 °F]	

• Temperature compensation table by adjustment value (difference value against current temperature)

Ex) If you change compensation resistance at the refrigerator (RCR1) from 10k (current resistance) to 18k (modified resistance), the temperature at the refrigerator will increase by +1°C [+1.8°F].

7. ICEMAKER AND DISPENSER WORKING PRICIPLES AND REPAIR

1. Working Principles

1-1 Ice Maker working Principles

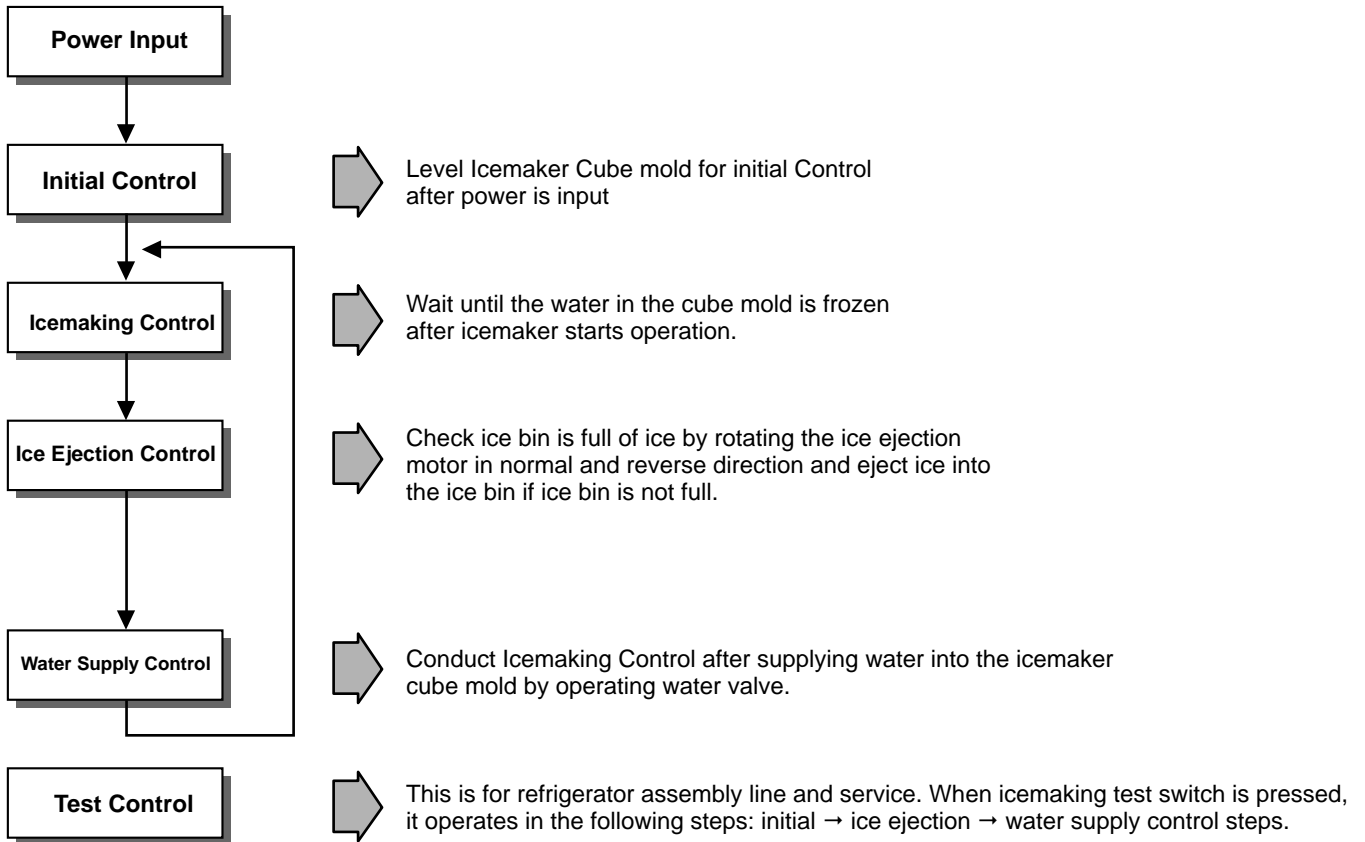

1-2 Dispenser Working Principles

1. This function is available in models where water and ice are available without opening freezer compartment door.
2. **Crushed Ice** is automatically selected when power is initially applied or reapplied after power cut.
3. When dispenser selection switch is continuously pressed, light is on in the following sequence:
Water → Cube Ice → Crushed Ice.
4. Lamp is on when dispenser button is pressed and vice versa.
5. When dispenser crushed ice rubber button is pressed, dispenser solenoid and geared motor work so that crushed ice can be dispensed if there is ice in the ice bin.
6. If there is ice in the bin, pushing the dispenser button will dispense it.
7. When dispenser water button is pressed, water valve opens and water is supplied if water valve is normally installed on the right side of the machine room.
8. Ice and water are not available when freezer door is open.

2. Function of Ice Maker

2-1 Initial Control Function

1. When power is initially applied or reapplied after power cut, it detects level of ice maker cube mold after completion of MICOM initialization. The detecting lever moves up and down.
2. The level of ice maker cube mold is judged by output signal, high and low signal, of Hall IC. Make the cube mold to be horizontal by rotating ice ejection motor in normal or reverse direction so that High/Low signal can be applied to MICOM Pin No.42
3. If there is no change in signal one minute after the geared motor starts to operate, it stops icemaker operation and check the signal every hour. It resets initialization of icemaker when it becomes normal.
4. It judges that the initial control is completed when it judges the icemaker cube mold is horizontal.
5. Ice ejection conducts for 1 cycle regardless of ice in the ice bin when power is initially applied.

2-2 Water Supply Control Function

1. This is to supply water into the icemaker cube mold by operating water valve in the mechanical area when ice ejection control is completed and ice maker mold is even.
2. The quantity of water supplied is determined by DIP switch and time.

Water Supply Quantity Table

No	DIP SWITCH SETTING		Water Supply Time
	S1	S2	
1	OFF	OFF	6.5SEC
2	ON	OFF	5.5SEC
3	OFF	ON	7.5SEC
4	ON	ON	8.5SEC
5			
6			
7			
8			

3. If the water supply quantity setting is changed while the power is on, the change will take effect immediately. If it is changed while the icemaker is filling the mold, the new setting will take effect the next time the icemaker cycles.
4. When water supply signal is applied to water and ice valves at the same time during water supply, water shall be supplied to water valve. If water supply signal is applied to ice valve during water supply, water shall be supplied to both water and ice valves.

2-3 Icemaking Control Function

1. Icemaking control is carried out from the completion of water supply to the completion of ice making in the cube mold. Icemaking sensor detects the temperatures of cube mold and completes ice making. (Ice making sensor is fixed below ice maker cube mold).
2. Icemaking control starts after completion of water supply control or initial control.
3. The icemaker determined its cycle is completed when the Icemaking sensor reaches -8°C (17.6°F) after 100 minutes have passed since water filled the mold.
4. It is judged that icemaking is completed when icemaker sensor temperature reaches belows -12°C after 20 minutes in condition 3.

2-4 Ice ejection Control Function

1. This is to eject ice from ice maker cube mold after icemaking is completed.
2. IF Hall IC signal is on within 3 6/10 seconds after ice ejection motor rotates in normal direction, it does not proceed ice ejection but waits. If the ice bank is full, ice ejection motor rotates in normal direction in every hour to check the condition of ice bank. If the ice bank is not full, the water supply control starts after completion of ice ejection control. If the ice bin is full, ice ejection motor rotates in reverse direction and stops under icemaking or waiting conditions.
3. If ice bin is not full, ice ejection starts. The cube mold tilts to the maximum and ice is separated from the mold and ice checking lever raises.
4. Ice ejection motor stops for 1 second if Hall IC signal changes from OFF (low) to ON (high) after 3 6/10 seconds when ice ejection motor rotates in normal direction. If there is no change in Hall IC signals within 1 minute after ice ejection motor operates, ice ejection motor stops as ice ejection motor or hall IC is out of order.

5. If ice ejection motor or Hall IC is abnormal, ice ejection motor rotates in normal direction to exercise initial operation. It resets the ice maker if ice ejection motor or Hall IC is normal.
6. The mold stops for 1 second at maximum tilted conditions.
7. The mold returns to horizontal conditions as ice ejection motor rotates in reverse direction.
8. When the mold becomes horizontal, the cycle starts to repeat:
Water Supply → Ice Making → Ice Ejection → Mold Returns to Horizontal

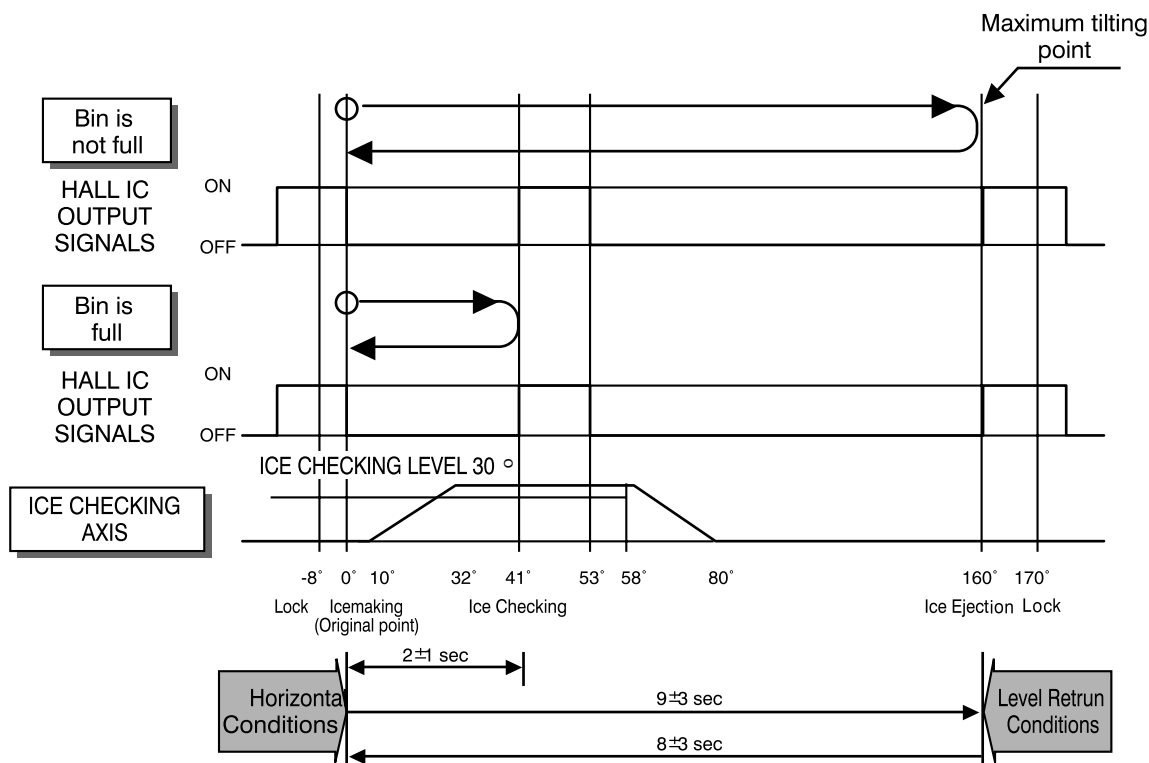

2-5 Test Function

1. It is to force the operation during operation test, service and cleaning. The test switch is mounted under the automatic icemaker. The test function starts when the test switch is pressed for more than ½ second.
2. Test button does not work during ice ejection and water supply. It works when it is in the horizontal conditions. If mold is full of ice during test function operation, ice ejection control and water supply control do not work.
3. If the mold is in the horizontal (normal) position and the TEST switch is pressed for more than ½ second, ice ejection will be regardless of how frozen the water might be. When the ejection is completed, the ice maker will refill the mold with water. Consequently, problems related to filling, ejecting and returning to the horizontal position can be checked using the test switch. When this test is performed, the buzzer will sound and water will fill the mold. Check the icemaker for repair if the buzzer does not sound.
4. When water supply is completed, the cycle operates normally as follows:
Icemaking → Ice Ejection → Returning to horizontal conditions → Water supply
5. Remove ice from the icemaker cube mold and press test switch when icemaker cube mold is full of ice as ice ejection and water supply control do not work when cube mold is full of ice.

2-6 Other functions relating to freezer compartment door opening

1. When freezer door is open, ice dispenser stops in order to reduce noise and ice drop.
2. When freezer door is open during ice ejection and cube mold returning to horizontal condition, ice ejection and cube mold level return proceed.
3. When freezer door is open, geared motor and cube ice solenoid immediately stop and duct solenoid stops after 5 seconds.
4. Water dispenser stops in order to protect water drop when freezer door is open.
5. Test function operates normally regardless of refrigerator compartment door opening.

3. Icemaker Troubleshooting

Troubleshooting: it is possible to confirm by pressing freezer and refrigerator temperature control buttons for more than 1 second. (Icemaker is normal if all LED's are on). Refer to trouble diagnosis function in MICOM function.

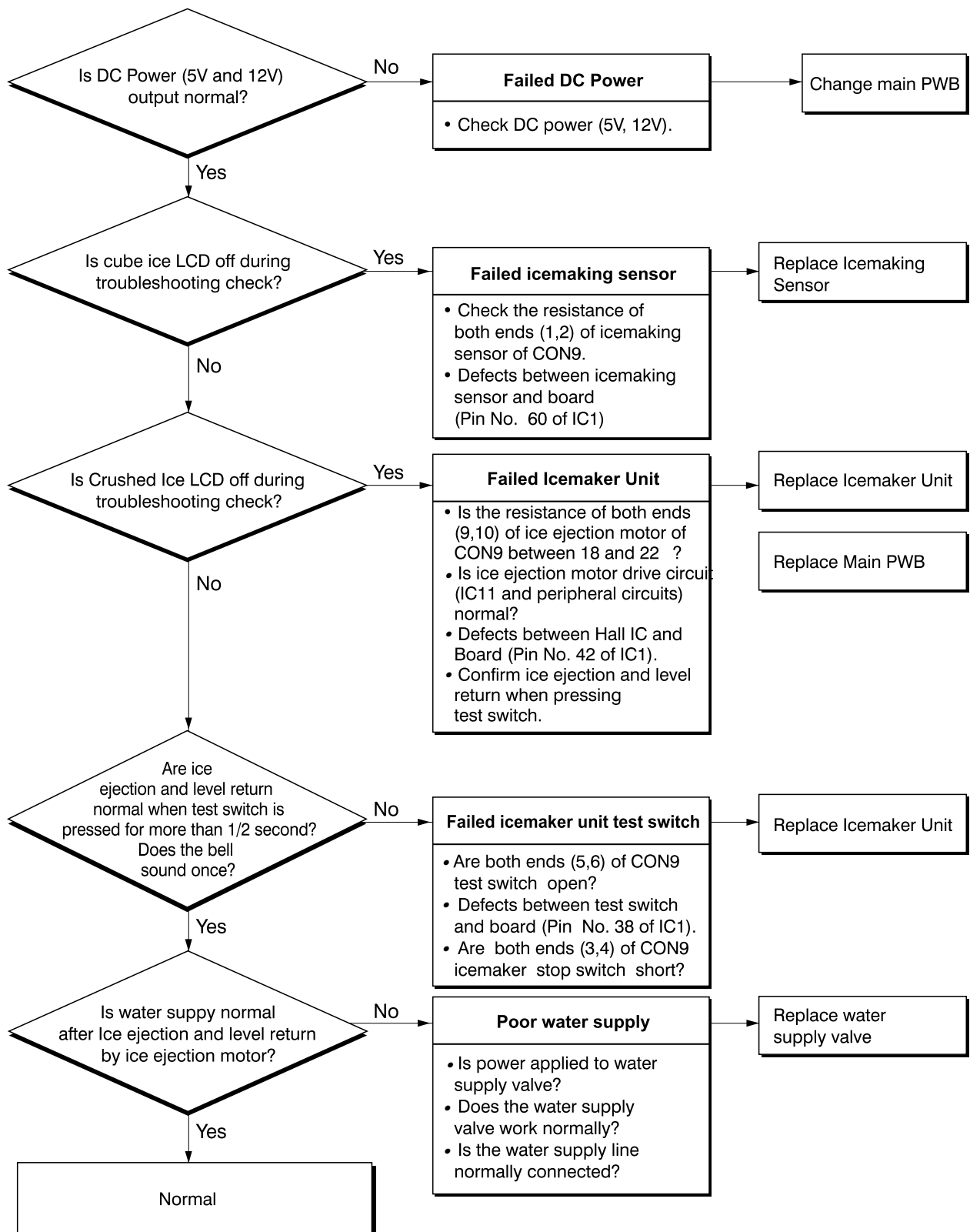

3. Icemaker Circuit

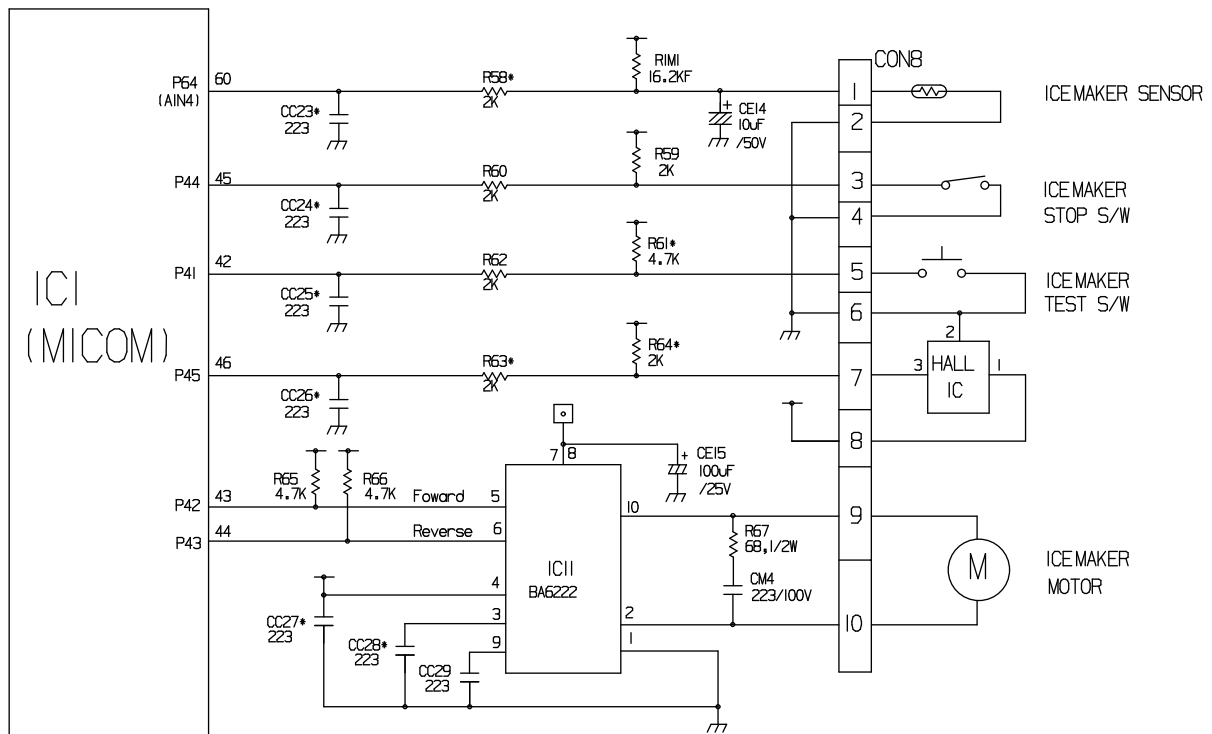

The above icemaker circuits are applied to ***** models and composed of icemaker unit in the freezer and icemaker driving part of main PWB. Water is supplied to the icemaker cube mold through the solenoid relay for ice valve of solenoid valve in the mechanical area by opening valve for the set time. Water supply automatically stops when water supply time is elapsed. This circuit is to realize the functions such as ice ejection of icemaker cube mold, ice full detection, leveling, Ice making temperature detection, etc. Refer to the temperature detecting circuits of Main PWB for Ice making temperature detection. Icemaker test switch input detection is the same as the door switch input detection circuit of main PWB.

1. It is to force to operate during operation test, service, and cleaning. The test switch is mounted under the automatic icemaker. The test function starts when the test switch is pressed for more than 1/2 second.
2. Test button does not work during ice ejection and water supply. It works when it is in the horizontal conditions. If cube mold is full of ice during test function operation, ice ejection control and water supply control do not work.
3. Ice ejection carries out regardless of ice formation in the ice making tray if test switch is pressed for more than 1/2 second. Water will be splashed if test switch is pressed before the water in the mold is completely frozen. Water will be supplied while the mold returns to the horizontal conditions after ice ejection. Therefore, the problems of ice ejection, leveling, and water supply can be checked by test switch. When test function performs normally, buzzer sounds and water supply shall carry out. Check it for repair if buzzer does not sound.
4. When water supply is completed, normal cycle works: Icemaking Ice Ejection Level Return Water Supply.
5. If icemaker stop switch is set to ON, normal cycle operates: Icemaking Ice Ejection Level Return Water Supply. If is set to OFF, ice making conducts but ice ejection, level return, and water supply do not work.

8. TROUBLE DIAGNOSIS

1. Troubleshooting

CLAIMS.	CAUSES AND CHECK POINTS.	HOW TO CHECK
<p>1. Faulty start</p>	<p>1) No power at outlet. 2) No power on cord.</p> <ul style="list-style-type: none"> └ Bad connection between adapter and outlet. (faulty adapter) <ul style="list-style-type: none"> └ The Inner diameter of adapter. └ The distance between holes. └ The distance between terminals. └ The thickness of terminal. └ Bad connection between plug and adapter (faulty plug). <ul style="list-style-type: none"> └ The distance between pins. └ Pin outer diameter. <p>3) Shorted start circuit.</p> <ul style="list-style-type: none"> └ No power on power cord. <ul style="list-style-type: none"> └ Disconnected copper wire. <ul style="list-style-type: none"> └ Power cord is disconnected. └ Faulty soldering. └ Internal electrical short. └ Faulty terminal contact. <ul style="list-style-type: none"> └ Loose contact. <ul style="list-style-type: none"> - Large distance between male terminal. - Thin female terminal. └ Terminal disconnected. └ Bad sleeve assembly. └ Disconnected. <ul style="list-style-type: none"> └ Weak connection. └ Short inserted cord length. └ Worn out tool blade. └ OLP is off. <ul style="list-style-type: none"> └ Capacity of OLP is small. └ Characteristics of OLP is bad. └ Bad connection. └ Power is disconnected. <ul style="list-style-type: none"> └ Inner Ni-Cr wire blows out. └ Bad internal connection. └ Faulty terminal caulking (Cu wire is cut). └ Bad soldering. └ No electric power on compressor. - Faulty compressor. └ Faulty PTC. <ul style="list-style-type: none"> └ Power does not conduct. - Damage. └ Bad characteristics. - Initial resistance is big. └ Bad connection with compressor. <ul style="list-style-type: none"> └ Too loose. └ Assembly is not possible. └ Bad terminal connection. <p>4) During defrost.</p> <ul style="list-style-type: none"> └ Start automatic defrost. └ Cycle was set at defrost when the refrigerator was produced. 	<p>* Measuring instrument: Multi tester</p> <p>Check the voltage. If the voltage is within $\pm 85\%$ of the rated voltage, it is OK.</p> <p>Check the terminal movement.</p> <p>Check both terminals of power cord. Power conducts:OK. No power conducts:NG</p> <p>Check both terminals of OLP If power conducts:OK. If not:NG.</p> <p>Check the resistance of both terminals. At normal temperature 6: OK. If disconnected:</p>

CLAIMS.	CAUSES AND CHECK POINTS.	HOW TO CHECK
<p>2. No cooling.</p>	<p>2) Refrigeration system is clogged.</p> <ul style="list-style-type: none"> Moisture clogged. <ul style="list-style-type: none"> Residual moisture in the evaporator. <ul style="list-style-type: none"> Air Blowing. <ul style="list-style-type: none"> Not performed. Too short. Impossible moisture confirmation. Low air pressure. Leave it in the air. <ul style="list-style-type: none"> During rest time. After work. Caps are missed. Residual moisture. <ul style="list-style-type: none"> Not dried in the compressor. Elapsed more than 6 months after drying Caps are missed. No pressure when it is open. No electric power on thermostat. <ul style="list-style-type: none"> Insufficient drier capacity. <ul style="list-style-type: none"> Dry drier - Drier temperature. Leave it in the air. <ul style="list-style-type: none"> Check on package condition. Good storage after finishing. Residual moisture in pipes. <ul style="list-style-type: none"> Caps are missed. <ul style="list-style-type: none"> During transportation. During work. Air blowing. <ul style="list-style-type: none"> Not performed. Performed. <ul style="list-style-type: none"> Too short time. Low air pressure. Less dry air. Moisture penetration - Leave it in the air. - Moisture penetration into the refrigeration oil. Weld joint clogged. <ul style="list-style-type: none"> Short pipe insert. Pipe gaps. <ul style="list-style-type: none"> Too large. Damaged pipes. Too much solder. Drier clogging. <ul style="list-style-type: none"> The capillary tube inserted depth. - Too much. Capillary tube melts. - Over heat. Clogged with foreign materials. <ul style="list-style-type: none"> Desiccant powder. Weld oxides. Drier angle. Reduced cross section by cutting. - Squeezed. Foreign material clogging. <ul style="list-style-type: none"> Compressor cap is disconnected. Foreign materials are in the pipe. 	<p>Heat a clogged evaporator to check it. As soon as the cracking sound starts, the evaporator will begin to freeze.</p> <p>The evaporator does not cool from the beginning (no evidence of moisture attached). The evaporator is the same as before even heat is applied.</p>

CLAIMS.	CAUSES AND CHECK POINTS.	HOW TO CHECK
<p>3. Poor Cooling</p>	<p>1) Refrigerant Partly leaked. [Weld joint leak. Parts leak.</p> <p>2) Poor defrosting capacity.</p> <ul style="list-style-type: none"> - Drain path (pipe) clogged. <ul style="list-style-type: none"> - Inject adiabatics into drain hose. <ul style="list-style-type: none"> - Inject through the hole. - Seal with drain. - Foreign materials penetration. <ul style="list-style-type: none"> - Adiabatics lump input. - Damage by a screw or clamp. - Other foreign materials input - Cap drain is not disconnected. - Defrost heater does not generate heat. <ul style="list-style-type: none"> - Parts disconnected. <ul style="list-style-type: none"> - Plate heater <ul style="list-style-type: none"> - Wire is cut. - Heating wire. - Contact point between heating and electric wire. - Dent by fin evaporator - Poor terminal contacts. - Cord heater <ul style="list-style-type: none"> - Wire is cut. - Lead wire. - Heating wire. - Contact point between heating and electric wire. - Heating wire is corroded - Water penetration. - Bad terminal connection 	<p>Check visually.</p> <p>Check terminal Conduction: OK. No conduction: NG. If wire is not cut, refer to resistance. P=Power V=Voltage R=Resistance</p> $P = \frac{V^2}{R}$ $R = \frac{V^2}{P}$

CLAIMS.	CAUSES AND CHECK POINTS.	HOW TO CHECK
<p>3. Poor Cooling</p>	<ul style="list-style-type: none"> - Residual frost. <ul style="list-style-type: none"> - Weak heat from heater. - Sheath Heater - rated. - Too short defrosting time. <ul style="list-style-type: none"> - Defrost Sensor. - Faulty characteristics. - Seat - (missing, location, thickness) - Structural fault. <ul style="list-style-type: none"> - Gasket gap. - Air inflow through the fan motor. - Bad insulation of case door. - No automatic defrosting. - Defrost does not return. 3) Cooling air leak. <ul style="list-style-type: none"> - Bad gasket adhesion <ul style="list-style-type: none"> - Gap. - Bad attachment. - Contraction. - Door sag. <ul style="list-style-type: none"> - Bad adhesion. - Weak binding force at hinge. 4) No cooling air circulation. <ul style="list-style-type: none"> - Faulty fan motor. <ul style="list-style-type: none"> - Fan motor. <ul style="list-style-type: none"> - Self locked. - Wire is cut. - Bad terminal contact. - Door switch. <ul style="list-style-type: none"> - Faults. <ul style="list-style-type: none"> - Contact distance. - Button pressure. - Melted contact. - Contact. - Refrigerator and freezer switch reversed. - Button is not pressed <ul style="list-style-type: none"> - Poor door attachment. - Door liner (dimension). - Contraction inner liner. - Misalignment. - Bad terminal connection. - Adiabatics liquid leak. 	<p>Check the fan motor conduction: OK. No conduction: NG.</p>

CLAIMS.	CAUSES AND CHECK POINTS.	HOW TO CHECK
<p>4. Warm refrigerator compartment temperature.</p>	<p>1) Clogged cooling path.</p> <ul style="list-style-type: none"> └ Adiabatics liquid leak ?. └ Foreign materials. — Adiabatics dump liquid <p>2) Food storage.</p> <ul style="list-style-type: none"> └ Store hot food. └ Store too much at once. └ Door open. └ Packages block air flow. 	
<p>5. No automatic operation. (faulty contacts)</p>	<p>1) Faulty temperature sensor in freezer or refrigerator compartment</p> <ul style="list-style-type: none"> └ Faulty contact. └ Faulty temperature characteristics. <p>2) Refrigeration load is too much.</p> <ul style="list-style-type: none"> └ Food. <ul style="list-style-type: none"> └ Too much food. └ Hot food. └ Frequent opening and closing. └ Cool air leak. └ Poor door close. — Partly opens. <p>3) Poor insulation.</p> <p>4) Bad radiation.</p> <ul style="list-style-type: none"> └ High ambient temperature. └ Insufficient space around refrigerator. <p>5) Refrigerant leak.</p> <p>6) Inadequate of refrigerant.</p> <p>7) Weak compressor discharging power.</p> <ul style="list-style-type: none"> └ Different rating. └ Small capacity. <p>8) Fan does not work.</p> <p>9) Button is set <i>at strong</i> .</p>	<p>Inspect parts measurements and check visually.</p>
<p>6. Condensation and ice formation.</p>	<p>1) Ice in freezer compartment.</p> <ul style="list-style-type: none"> └ External air inflow. — Bushing installed incorrectly. └ Door opens but not closes. <ul style="list-style-type: none"> └ Weak door closing power. └ Stopper malfunction. └ Door sag. └ Food hinders door closing. └ Gap around gasket. — Contraction, distortion, loose, door twisted, corner not fully inserted. └ Food vapor. — Storing hot food. — Unsealed food. <p>2) Condensation in the refrigerator compartment.</p> <ul style="list-style-type: none"> └ Door opens but not closes. <ul style="list-style-type: none"> └ Insufficient closing. └ Door sag. └ Food hinders door closing. └ Gasket gap. <p>3) Condensation on liner foam.</p> <ul style="list-style-type: none"> └ Cool air leak and transmitted. <ul style="list-style-type: none"> └ Not fully filled. <ul style="list-style-type: none"> └ Top table part. └ Out plate Ref/Lower part. └ Flange gap. — Not sealed. └ Gasket gap. 	

CLAIMS.	CAUSES AND CHECK POINTS.	HOW TO CHECK
<p>6. Condensation and ice formation.</p>	<p>4) Condensation on door.</p> <ul style="list-style-type: none"> Condensation on the duct door. - Duct door heater is cut. Condensation on the dispense recess. <ul style="list-style-type: none"> Recess Heater is cut. Duct door is open. / Foreign material clogging. Condensation on the door surface. <ul style="list-style-type: none"> Not fully filled. <ul style="list-style-type: none"> Surface - Liquid shortage. Corner. - Liquid leak. Adiabatics liquid contraction. Condensation on the gasket surface. <ul style="list-style-type: none"> Bad wing adhesion. <ul style="list-style-type: none"> Wing sag(lower part). Door liner shape mismatch. Corner. <ul style="list-style-type: none"> Too much notch. Broken. Home Bar heater is cut. <p>5) Water on the floor.</p> <ul style="list-style-type: none"> Condensation in the refrigerator compartment. Defrosted water overflows. — Clogged discharging hose. Discharging hose — Evaporation tray located at wrong place location. Tray drip. <ul style="list-style-type: none"> Damaged. Breaks, holes. Small Capacity. Position of drain. 	
<p>7. Sounds</p>	<p>1) Compressor compartment operating sounds.</p> <ul style="list-style-type: none"> Compressor sound inserted. <ul style="list-style-type: none"> Sound from machine itself. Sound from vibration. <ul style="list-style-type: none"> Restrainer. Bushing seat. <ul style="list-style-type: none"> Too hard. Distorted. Aged. Burnt. Stopper. — Bad Stopper assembly. <ul style="list-style-type: none"> Not fit (inner diameter of stopper). Tilted. Not Compressor base not connected. Bad welding compressor stand(fallen). Foreign materials in the compressor compartment. OLP sound. — Chattering sound. Capacitor noise. — Insulation paper vibration. Pipe sound. <ul style="list-style-type: none"> Pipe contacts each other. - Narrow interval. No vibration damper. Damping Bushing-Q. Damping Bushing-S. Capillary tube unattached. 	

CLAIMS.	CAUSES AND CHECK POINTS.	HOW TO CHECK
<p>7. Sounds</p>	<p>1) Compressor compartment operating sounds.</p> <ul style="list-style-type: none"> — Transformersound. <ul style="list-style-type: none"> — Its own fault. — Core gap. — Bad connection. — Correct screw connection. — Drip tray vibration sound. <ul style="list-style-type: none"> — Bad assembly. — Distortion. — Foreign materials inside. — Back cover machine sound. <ul style="list-style-type: none"> — Bad connection. — Partly damaged. — Condenser drain sound. <ul style="list-style-type: none"> — Not connected. — Bad pipe caulking. <p>2) Freezer compartment sounds.</p> <ul style="list-style-type: none"> — Fan motor sound. <ul style="list-style-type: none"> — Normal operating sound. — Vibration sound. <ul style="list-style-type: none"> — Aged rubber seat. — Bad torque for assembling motor bracket. — Sounds from fan contact. <ul style="list-style-type: none"> — Fan guide contact. — Shroud burr contact. — Damping evaporator contact. — Residual frost contact. <ul style="list-style-type: none"> — Damaged heater cord. — Narrow evaporator interval. — Unbalance fan sounds. <ul style="list-style-type: none"> — Unbalance. <ul style="list-style-type: none"> — Surface machining conditions. — Fan distortion. — Misshappen. — Burr. — Ice on the fan. — Air intake (opposite to motor bushing assembly) — Motor shaft contact sounds. <ul style="list-style-type: none"> — Supporter disorted. — Tilted during motor assembly. — Resonance. — Evaporator noise. <ul style="list-style-type: none"> — Evaporator pipe contact. —No damping evaporator — Sound from refrigerant. —Stainless steel pipe shape in accumulator. — Sound from fin evaporator and pipe during expansion and contraction. <p>3) Bowls and bottles make contact on top shelf.</p> <p>4) Refrigerator roof contact.</p> <p>5) Refrigerator side contact.</p> <p>6) Insufficient lubricants on door hinge.</p>	

CLAIMS.	CAUSES AND CHECK POINTS.	HOW TO CHECK
<p>8. Faulty lamp (freezer and refrigerator compartment).</p>	<p>1) Lamp problem. — Filament blows out. — Glass is broken.</p> <p>2) Bad lamp assembly. — Not inserted. — Loosened by vibration.</p> <p>3) Bad lamp socket.</p> <ul style="list-style-type: none"> — Disconnection. — Bad soldering. — Bad rivet contact. — Short. — Water penetration. — Low water level in tray. — Bad elasticity of contact. — Bad contact (corrosion). <p>4) Door switch.</p> <ul style="list-style-type: none"> — Defective. — Refrigerator and freezer switches are reversed — Travel distance. — Bad connection. — Bad terminal contact. — Adiabatics liquid leak. 	
<p>9. Faulty internal voltage (short).</p>	<p>1) Lead wire is damaged.</p> <ul style="list-style-type: none"> — Wire damage when assembling PTC Cover. — Outlet burr in the bottom plate. — Pressed by cord heater. lead wire, evaporator pipe. <p>2) Exposed terminal.</p> <ul style="list-style-type: none"> — Compressor Compartment terminal. - Touching other components. — Freezer compartment terminal. - Touching evaporator pipe. <p>3) Faulty parts.</p> <ul style="list-style-type: none"> — Transformer. — Coil contacts cover. — Welded terminal parts contact cover. — Compressor. — Bad coil insulation. — Plate heater. — Melting fuse. — Sealing is broken. — Moisture penetration. — Cord heater. — Pipe damaged. — Moisture penetration. — Bad sealing. — Sheath heater. 	<p>Connect conduction and non-conduction parts and check with tester. Conduction: NG. Resistance : OK.</p>

CLAIMS.	CAUSES AND CHECK POINTS.	HOW TO CHECK
<p>10. Structure, appearance, and others.</p>	<p>1) Door foam.</p> <ul style="list-style-type: none"> Sag. <ul style="list-style-type: none"> Hinge loose <ul style="list-style-type: none"> Bolt is loosened during transportation. Not tightly fastened. Screw worn out . Weak gasket adhesion. <ul style="list-style-type: none"> Adhesion surface. Fixed tape. <ul style="list-style-type: none"> Not well fixed. Noise during operation. <ul style="list-style-type: none"> Hinge interference. <ul style="list-style-type: none"> Bigger door foam. Hinge-Pin tilted-Poor flatness. No washer. No grease. Malfunction. <ul style="list-style-type: none"> Not closed Refrigerator compartment is opened when freezer compartment is closed (faulty stopper). <ul style="list-style-type: none"> Interference between door liner and inner liner. <ul style="list-style-type: none"> Stopper worn out. Bad freezer compartment door assembly. No stopper. <p>2) Odor.</p> <ul style="list-style-type: none"> Temperature of refrigerator compartment. <ul style="list-style-type: none"> High. <ul style="list-style-type: none"> Faulty damper control. Button is set at weak. Door is open (interference by food). Deodorizer. <ul style="list-style-type: none"> No deodorizer. Poor capacity. Food Storage. <ul style="list-style-type: none"> Seal condition. Storage of fragrant foods. Long term storage. Others. <ul style="list-style-type: none"> Odors from cleaners or items which should not be stored in a refrigerator. 	

2. Faults

2-1. Power

Problems	Causes	Checks	Measures	Remarks
No power on outlet.	<ul style="list-style-type: none"> - Power cord cut. - Faulty connector insertion. - Faulty connection between plug and adapter. 	<ul style="list-style-type: none"> - Check the voltage with tester. - Check visually. - Check visually. 	<ul style="list-style-type: none"> - Replace the components. - Reconnect the connecting parts. - Reconnect the connecting parts. 	
Fuse blows out.	<ul style="list-style-type: none"> - Short circuit by wrong connection - Low voltage products are connected to high voltage. - Short circuit by insects. - Electricity leakage. - High voltage. - Short circuit of components (tracking due to moisture and dust penetration). 	<ul style="list-style-type: none"> - Check the fuse with tester or visually. - Check the input volt are with tester (between power cord and products). - Check the resistance of powercord with tester (if it is 0 it is shorted). 	<ul style="list-style-type: none"> - Find and remove the cause of problem (ex. short, high voltage, low voltage). - Replace with rated fuse. 	<p>Replace with rated fuse after confirming its specification.</p> <p>If fuse blows out frequently, confirm the cause and prevent.</p>

2-2. Compressor

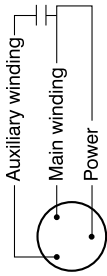
Problems	Causes	Checks	Measures	Remarks
Compressor does not operate.	<ul style="list-style-type: none"> - Faulty PTC. - Compressor is frozen. 	<ul style="list-style-type: none"> - Check the resistance. Value: is defective. - If compressor assembly parts are normal (capacitor, PTC, OLP), apply power directly to the compressor to force operation.  <p>OLP It starts as soon as it is contacted.</p>	<ul style="list-style-type: none"> - If resistance is infinite, replace it with new one. - If it is not infinite, it is normal. - Check other parts. - During forced operation: - Operates: Check other parts. - Not operate: Replace the frozen compressor with new one, weld, evacuate, and recharge refrigerant - Refer to weld repair procedures. 	

2-4. Cooling

Problems	Causes	Checks	Measures	Remarks
High temperature in the freezer compartment.	Refrigerant leak.	<p><u>Check sequence</u></p> <ol style="list-style-type: none"> 1. Check the welded parts of the drier inlet and outlet and drier auxiliary in the compressor compartment (high pressure side). 2. Check the end of compressor sealing pipe (low pressure side). 3. Check silver soldered parts. 4. Check bending area of wire condenser pipe in compressor compartment (cracks can happen during bending). 5. Check other parts (compressor compartment and evaporators in freezer compartment). 	Weld the leaking part, recharge the refrigerant.	Drier must be replaced.
	Shortage of refrigerant.	<p>Check frost formation on the surface of evaporator in the freezer compartment.</p> <ul style="list-style-type: none"> - If the frost forms evenly on the surface, it is OK. - If it does not, it is not good. 	<ul style="list-style-type: none"> - Find out the leaking area, repair, evacuate, and recharge the refrigerant. - No leaking, remove the remaining refrigerant, and recharge new refrigerant. 	Drier must be replaced.

2-4. Cooling

Problems	Causes	Checks	Measures	Remarks
High temperature in the freezer compartment.	Refrigerant leak.	<p><u>Check sequence</u></p> <ol style="list-style-type: none"> 1. Check the welded parts of the drier inlet and outlet and drier auxiliary in the compressor compartment (high pressure side). 2. Check the end of compressor sealing pipe (low pressure side). 3. Check silver soldered parts. 4. Check bending area of wire condenser pipe in compressor compartment (cracks can happen during bending). 5. Check other parts (compressor compartment and evaporators in freezer compartment). 	Weld the leaking part, recharge the refrigerant.	Drier must be replaced.
	Shortage of refrigerant.	<p>Check frost formation on the surface of evaporator in the freezer compartment.</p> <ul style="list-style-type: none"> - If the frost forms evenly on the surface, it is OK. - If it does not, it is not good. 	<ul style="list-style-type: none"> - Find out the leaking area, repair, evacuate, and recharge the refrigerant. - No leaking, remove the remaining refrigerant, and recharge new refrigerant. 	Drier must be replaced.

Problems	Causes	Checks	Measures	Remarks
High temperature in the freezer compartment.	Cycle pipe is clogged.	<p>Check sequence.</p> <ol style="list-style-type: none"> 1. Check temperature of condenser manually. If it is warm, OK. If it is not, compressor discharging joints might be clogged. 2. Manually check whether hot line pipe is warm. If it is warm, OK. If it is not, condenser outlet weld joints might be clogged. 	<p>- Heat up compressor discharging weld joints with touch, disconnect the pipes, and check the clogging. Remove the causes of clogging, weld, evacuate, and recharge the refrigerant. - If it's warm, OK. If it's not, condenser discharging line weld joints might be clogged. Disconnect with torch, remove the causes, evacuate, and recharge seal refrigerant.</p>	Drier must be replaced.
	Leak at loop pipe weld joint (discharge) in compressor.	<p>Check sequence.</p> <ol style="list-style-type: none"> 1. Manually check whether condenser is warm, it is not warm and the frost forms partly on the evaporator in the freezer compartment. 	<p>Replace the compressor, weld, evacuate, and recharge refrigerant.</p>	Drier must be replaced.
	Faulty cooling fan in the compressor compartment.	<p>Check sequence.</p> <ol style="list-style-type: none"> 1. Check cooling fan operation. 2. Check that cooling fan is disconnected from the motor. 	<p>- Replace if motor does not operate. - If fan is disconnected, check fan damage and reassemble it. Refer to fan motor disassembly and assembly sequence.</p>	

2-5. Defrosting failure

Problems	Causes	Checks	Measures	Remarks
No defrosting.	<p>Heater does not generate heat as the heating wire is cut or the circuit is shorted.</p> <p>1) Heating wire is damaged when inserting into the evaporator.</p> <p>2) Lead wire of heater is cut.</p> <p>3) Heating wire at lead wire contacts is cut.</p> <p>Suction tube and discharge orifice:</p> <p>1. Impurities.</p> <p>2. Ice.</p>	<p>1. Check the resistance of heater. 0 Ω: Short. ∞: Cut. Tens to thousands Ω: OK.</p> <p>2. Check the resistance between housing terminal and heater surface. 0 Ω: Short. ∞: Cut. Tens to thousands Ω: Short.</p> <p>1. Confirm foreign materials. In case of ice, insert the copper line through the hole to check.</p> <p>2. Put hot water into the drain (check drains outside).</p>	<p>Heating wire is short and wire is cut.</p> <p>Parts replacement: Refer to parts explanations.</p>	<p>Seal the lead wire with insulation tape and heat shrink tube if the cut lead wire is accessible to repair.</p>
			<p>1) Push out impurities by inserting copper wire. (Turn off more than 3 hours and pour in hot water if frost is severe.)</p> <p>2) Put in hot water to melt down frost</p> <p>3) Check the water outlet.</p> <p>4) Push the heater plate to suction duct manually and assemble the disconnected parts.</p>	
Gap between Suction duct and Heater plate (Ice in the gap).		<p>1. Confirm in the Suction duct.</p>	<p>1) Turn off the power, confirm impurities and ice in the gap, and supply hot water until the ice in the gap melts down.</p> <p>2) Push the Heater plate to drain bottom with hand and assemble the disconnected parts.</p>	
Wrong heater rating (or wrong assembly).		<p>1. Check heater label.</p> <p>2. Confirm the capacity after substituting the resistance value into the formula.</p> $P = \frac{V^2}{R}$ <p>(V: Rated voltage of user country) (R: Resistance of tester[?])</p> <p>Compare P and label capacity. Tolerance: ±7%</p>	<p>Faults: Replace.</p> <p>- How to replace : Refer to main parts.</p>	

Problems	Causes	Checks	Measures	Remarks
No defrosting	<p>Melting fuse blows.</p> <p>1) Lead wire is cut.</p> <p>2) Bad soldering.</p> <p>Ice in the Suction duct.</p> <p>1) Icing by foreign materials in the duct.</p> <p>2) Icing by cool air inflow through the gap of heater plate.</p> <p>3) Icing by the gap of heater plate.</p>	<p>- Check melting fuse with tester. - If 0 : OK. If : wire is cut.</p> <p>1. Check the inner duct with mirror.</p> <p>2. Check by inserting soft copper wire into the duct (soft and thin copper not to impair heating wire).</p>	<p>Faulty parts: parts replacement.</p> <p>- Check wire color when measuring resistance with a tester.</p> <p>1) Turn power off.</p> <p>2) Raise the front side (door side), support the front side legs, and let the ice melt naturally. (If power is on, melt the frost by forced defrosting.)</p> <p>3) Reassemble the heater plate.</p>	
	<p>Bad cool air inflow and discharge, and bad defrosting due to faulty contact and insertion (bad connector insertion into housing of heater, melting, fuse, and motor fan).</p>	<p>1. Turn on power, open or close the door, check that motor fan operates (if it operates, motor fan is OK).</p> <p>2. Disconnect parts in the refrigerator compartment, check the connection around the housing visually, defrost, and confirm heat generation on the heater. Do not put hands on the sheath heater.</p> <p>3. Check the parts which have faults described in 1 & 2 (mechanical model: disconnect thermostat from the assembly).</p>	<p>1) Check the faulty connector of housing and reassemble wrongly assembled parts.</p> <p>2) If the parts are damaged, remove the parts and replace it with a new one.</p>	

2-6. Icing

Problems	Causes	Checks	Measures	Remarks
Icing in the refrigerator compartment. - Damper icing. - Pipe icing. - Discharging pipe icing.	1) Bad circulation of cool air. - Clogged intake port in the refrigerator compartment. - Sealing is not good. - Too much food is stored and clogs the discharge port. - Bad defrosting.	- Check the food is stored properly (check discharge and intake port are clogged). - Check icing on the surface of baffle and cool air path (pipe) after disassembling the container box. - Check icing at intake ports of freezer and refrigerator compartment.	- Be acquainted with how to use. - Sealing on connecting parts. - Check the damper and replace it if it has defects. - Check defrost. (After forced defrosting, check ice in the evaporator and pipes.)	- Check the defrost related parts if problem is caused by faulty defrosting.
	2) Faulty door or refrigerator compartment. - Faulty gasket. - Faulty assembly.	- Check gasket attached conditions. - Check door assembly conditions.	- Correct the gasket attachment conditions and replace it. - Door assembly and replacement.	- Replacement should be done when it cannot be repaired.
	3) Overcooling in the refrigerator compartment. - Faulty damper in the refrigerator compartment. - Faulty MICOM (faulty sensor)	- Check refrigerator compartment is overcooled (when button pressed on weak). - Check parts are faulty.	- Replace faulty parts.	
	4) Bad defrosting - Heater wire is cut. - Defective defrost sensor. - Defrosting cycle.	- Check frost on the evaporator after disassembling shroud and fan grille. - Check ice on intake port of freezer and refrigerator compartment.	- Check parts related to defrosting. - Check defrosting. (Check ice on the evaporator and pipe.)	-Moisture does not freeze on the evaporator but can be sucked into the refrigerator, where it condenses and freezes. This interferes with cold air circulation and sublimation of the ice.
	5) Customers are not familiar with this machine. - Door opens. - High temperature, high moisture, and high load.	- Check food interferes with door closing. - Check ice on the ceilings.	- Be acquainted with how to use.	

Problems	Causes	Checks	Measures	Remarks
Ice in the freezer compartment. - Surface of fan grille. - Wall of freezer compartment. - Cool air discharging port. - Basket(rack) area.	1) Bad cooling air circulation. - Intake port is clogged in the freezer compartment. - Discharging port is Clogged. - Too much food is stored. - Bad defrosting.	- Check food storage conditions visually.(Check clogging at intake and discharging port of cooling air.) - Check food occupation ratio in volume (Less than 75%). - Check frost on the evaporator after dissembling shroud and fan grille. - Check icing at intake port of refrigerator compartment.	- Be acquainted with how to use. - Check defrost (Check ice on the evaporator and pipes after forced defrosting).	- Check the parts related to defrosting if the problem is caused by the faulty defrosting.
- Food surface. - Icing in the shute.	2) Bad freezer compartment door - Faulty gasket - Faulty assembly	- Check gasket attachment conditions. - Check door assembly conditions.	- Correct the gasket attachment conditions and replace it. - Door assembly and replacement.	- Replace when it can not be repaired.
	3) Over freezing in the freezer compartment. - Faulty MICOM.	- Refrigerator operates pull down. (Check if it is operated intermittently) - The Temperature of freezer compartment is satisfactory, but over freezing happens in the refrigerator compartment even though the notch is set at weak.	-Replace defective parts.	
	4) Bad defrosting. - Heater wire is cut. - Faulty defrost sensor. - Defrosting cycle	- Check frost on the evaporator after dissembling shroud and grille. - Check ice on the intake port in the refrigerator compartment.	- Check parts related to defrosting. - Check defrosting. Check ice on the evaporator and pipes after forced defrosting.	
	5) User is not familiar with how to use. - Door opens. - High moisture food water is stored.	- Check food holds door open. - Check ice on the ice tray.	- Be acquainted with how to use.	

2-7. Sound

Problems	Causes	Checks	Measures	Remarks
Hiss sound	1. Loud sound of compressor operation.	1.1 Check the level of the refrigerator. 1.2 Check the bushing seat conditions (sagging and aging).	1) Maintain horizontal level. 2) Replace bushing and seat if they are sagged and aged. 3) Touch the piping at various place along its route. Install a damper at the point where your touch reduces the noise. 4) Avoid pipe interference. 5) Replace defective fan and fan motor. 6) Adjust fan to be in the center of the fan guide. 7) Leave a clearance between interfering parts and seal gaps in the structures. 8) Reassemble the parts which make sound. 9) Leave a clearance if evaporator pipes and suction pipe touch freezer shroud.	
	2. Pipes resonate sound which is connected to the compressor.	2.1 Check the level of pipes connected to the compressor and their interference. 2.2 Check bushing inserting conditions in pipes. 2.3 Touch pipes with hands or screw -driver (check the change of sound).		
	3. Fan operation sound in the freezer compartment.	3.1 Check fan insertion depth and blade damage. 3.2 Check the interference with structures. 3.3 Check fan motor. 3.4 Check fan motor bushing insertion and aging conditions.		
	4. Fan operation sound in the compressor compartment.	4.1 Same as fan confirmation in the refrigerator. 4.2 Check drip tray leg insertion. 4.3 Check the screw fastening conditions at condenser and drip tray.		

Problems	Causes	Checks	Measures	Remarks
Vibration sound. Clack.	<ol style="list-style-type: none"> 1. Vibration of shelves and foods in the refrigerator. 2. Pipes interference and capillary tube touching in the compressor compartment. 3. Compressor stopper vibration. 4. Moving wheel vibration. 5. Other structure and parts vibration. 	<ol style="list-style-type: none"> 1-1. Remove and replace the shelves in the refrigerator 1-2. Check light food and container on the shelves. 2-1. Touch pipes in the compressor compartment with hands. 2-2. Check capillary tube touches cover back. 3-1. Check compressor stopper vibration. 4-1. Check vibration of front and rear moving wheels. 5-1. Touch other structures and parts. 	<ol style="list-style-type: none"> 1) Reassemble the vibrating parts and insert foam or cushion where vibration is severe. 2) Leave a clearance where parts interfere with each other. 3) Reduce vibration with bushing and restrainer if it is severe. (especially compressor and pipe). 4) Replace compressor stopper if it vibrates severely. 	
Irregular sound. Click .	<ol style="list-style-type: none"> 1. It is caused by heat expansion and contraction of evaporator, shelves, and pipes in the refrigerator. 	<ol style="list-style-type: none"> 1-1 Check time and place of sound sources. 	<ol style="list-style-type: none"> 1) Explain the principles of refrigeration and that the temperature difference between operation and defrosting can make sounds. 2) If evaporator pipe contacts with other structures, leave a clearance between them (freezer shroud or inner case). 	

Problems	Causes	Checks	Measures	Remarks
Sound Popping (almost the same as animal's crying sound).	It happens when refrigerant expands at the end of capillary tube.	<ul style="list-style-type: none"> - Check the sound of refrigerant at the initial installation. - Check the sound when the refrigerator starts operation after forced defrosting. - Check the restrainer attachment conditions on the evaporator and capillary tube weld joints. 	<ul style="list-style-type: none"> - Check the restrainer attached on the evaporator and capillary tube weld joints and attach another restrainer. - If it is continuous and severe, insert capillary tube again (depth 15±3mm) - Fasten the capillary tube to suction pipes or detach in the compressor compartment. - Explain the principles of freezing cycles. 	
Water boiling or flowing sound.	It happens when refrigerant passes orifice in accumulator internal pipes by the pressure difference between condenser and evaporator.	<ul style="list-style-type: none"> - Check the sound when compressor is turned on. - Check the sound when compressor is turned off. 	<ul style="list-style-type: none"> - Explain the principles of freezing cycles and refrigerant flowing phenomenon by internal pressure difference. - If sound is severe, wrap the accumulator with foam and restrainer. 	
Sound of whistle when door closes.	When door closes, the internal pressure of the refrigerator decreases sharply below atmosphere and sucks air into the refrigerator, making the whistle sound.	<ul style="list-style-type: none"> - Check the sound by opening and closing the refrigerator or freezer doors. 	<ul style="list-style-type: none"> - Broaden the cap of discharge hose for defrosting in the compressor compartment. - Seal the gap with sealant between out and inner cases of hinge in door. 	

2-8. Odor

Problems	Causes	Checks	Measures	Remarks
Food Odor.	Food (garlic, kimchi, etc)	<ul style="list-style-type: none"> - Check the food is not wrapped. - Check the shelves or inner wall are stained with food juice. - Be sure food is securely covered with plastic wrap. - Check food cleanliness. 	<ul style="list-style-type: none"> - Dry the deodorizer in a sunny place with adequate ventilation. - Store the food in the closed container instead of vinyl wraps. - Clean the refrigerator and set button at strong . 	
Plastic Odor.	Odors of mixed food and plastic odors.	<ul style="list-style-type: none"> - Check wet food is wrapped with plastic bowl and bag. - It happens in the new refrigerator. 	<ul style="list-style-type: none"> - Clean the refrigerator. - Persuade customers not to use plastic bag or wraps with wet food or odorous foods. 	
Odor from the deodorizer.	Odor from the old deodorizer.	<ul style="list-style-type: none"> - Check the deodorizer odors. 	<ul style="list-style-type: none"> - Dry the deodorizer with dryer and then in the shiny and windy place. - Remove and replace the deodorants. 	*Deodorizer : option

2-9. MICOM

Problems	Symptom	Causes		Checks	Measures	Remarks
Bad PCB electric power.	All display LCD are off.	Bad connection between Main PCB and display circuit.	Bad connector connection from main PCB to display PCB.	Visual check on connector connection.	Reconnect connector.	
		Defective PCB transformer.	PCB transformer winding is cut. PCB transformer temperature fuse is burnt out.	Check resistance of PCB transformer input and output terminals with a tester. (If resistance is infinity, trans winding is cut).	Replace PCB transformer or PCB.	Applicable to model without dispenser.
Abnormal display LCD operation	Defective LCD.	Defective PCB electric circuit parts.	Defective regulator IC (7812, 7805).	Check voltage at input/output terminals.	Replace regulator.	Refer to electric circuit in circuit explanation.
			PCB electric terminal fuse is burned out.	Check fuse in PCB electric terminal with a tester.	Replace PCB fuse.	
			STR Parts are damaged.	Check if STR No. 2 and 3 pins are cut when power is off.	Replace parts.	Applicable to model with dispenser.
		Bad connection between Main PCB and display circuit.	Lead Wire connecting main PCB and display PCB is cut or connector terminal connection is bad.	Check Lead Wire terminals connecting Main PCB and display PCB with a tester.	Reconnect Lead Wire and directly connect defective contact terminal to Lead Wire.	
		Defective LCD.	Defective LCD.	Check if all LCD are on when Main PCB Test switch is pressed (or when both freezer key and power freezer key are pressed at the same time for more than one second.)	Replace display PCB.	Refer to display circuit in circuit explanation.









Problems	Symptom	Causes		Checks	Measures	Remarks	
Bad cooling.	Freezer temperature is high.	Compressor does not start.	Compressor Lead Wire is cut.	Check compressor Lead Wire with a tester.	Reconnect Lead Wire.		
			Defective compressor driving relay.	Measure voltage at PCB CON2 (3&9) after pressing main PCB test switch once. It is OK if voltage is normal.	Replace relay RY1 and RY2 or PCB.	Refer to load driving circuit in circuit explanation.	
		Defective freezer sensor.	Defective Freezer sensor parts.	Check resistance of freezer sensor with a tester.	Replace freezer sensor.	Refer to resistance characteristics table of sensor in circuit. Refer to tables on pages 39~42	
			The wrong sensor has been installed. Order by model number and part number.	Confirm the color of sensor in circuits (main PCB sensor housing).	Repair main PCB sensor housing		
Defective freezer fan motor.	Fan motor lead wire is cut.	Fan motor lead wire is cut.	Check fan motor lead wire with a tester.	Reconnect lead wire.			
		•Defective door switch (freezer, refrigerator, home bar). Defective fan motor. •Defective fan motor driving relay.	Measure the voltage between PCB power blue line and fan motor after pressing test switch of Main PCB. If the voltage is normal, it is OK.	<ul style="list-style-type: none"> Replace door switch (freezer, refrigerator, and home bar). Replace fan motor. Replace relay RY5 & RY6 or PCB. 	Refer to load driving circuits in circuit explanation.		
	Faulty defrost.		Refer to faulty defrost items in trouble diagnosis functions.			Refer to trouble diagnosis function.	

Problems	Symptom	Causes	Checks	Measures	Remarks		
Bad cooling	Wrong Refrigerator temperature.	Defective Step Motor Damper.	Check Step Motor damper motor and reed switch and lead wire are cut. Check Step Motor damper part.	Check if Step Motor damper motor and reed switch lead wire are cut with a tester. Refer to Step Motor damper in parts repair guide.	Reconnect lead wire. Replace Step Motor damper or refrigerator control box Assembly.		
			Check Step Motor damper Motor driving relay in PCB.	Refer to Step Motor damper in parts repair guide.	Replace relay or PCB.	Refer to single motor damper driving circuits in circuit explanation.	
		Foreign materials in Step Motor damper baffles. Ice formation on Step Motor damper baffles.	Check Step Motor damper baffle visually.	Remove foreign materials.			
			Check if Step Motor damper Heater wire is cut with a tester.	Replace Step Motor damper or refrigerator control Box Assembly.			
			Defective refrigerator sensor parts.	Check the resistance of refrigerator sensor with a tester.	Replace refrigerator sensor.	Refer to sensor resistance characteristic table in circuit explanation.	
		Defective refrigerator sensor	Refrigerator sensor is substituted for other sensor.	Check the sensor color in the circuit. (main PCB sensor housing.)	Repair main PCB sensor housing.		
			Defective refrigerator sensor assembly condition.	Check if refrigerator sensor is not fixed at cover sensor but inner case visually.	Fix again the refrigerator sensor.		

Problems	Symptom	Causes	Checks	Measures	Remarks
Bad defrost.	Defrost is not working.	Defrost lead wire is cut.	Check if defrost lead wire is cut with a tester.	Reconnect Lead Wire.	
		Defective defrost driving relay.	Check the voltage of CON2 (1 and 7) with a tester after pressing main PCB test switch twice. If the voltage is normal then it is OK.	Replace relay (RY7 and RY 3) or PCB.	Refer to load driving conditions check in circuit explanation.
		Defective defrost sensor parts.	Check the resistance of defrost sensor with a tester.	Replace defrost sensor.	Refer to sensor resistance characteristic table of circuit explanation.
Defective buzzer	Buzzer continuously rings or door opening alarm does not work.	Defective connecting lead wire from main PCB to door switch.	Check lead wire related to door switch with a tester.	Repair lead wire.	
		Defective door switch parts.	Refer to door switch in parts repair guide.	Replace door switch	
Defective display button	Buzzer does not sound and buttons do not operate.	Key input wire is cut or bad connector terminal contact in main PCB and display PCB connecting lead wire.	Check input wire with a tester.	Reconnect lead wire and replace or directly connect bad contact terminal to lead wire.	Refer to display circuit in circuit explanation.
		Key is continuously depressed due to structural interference.	Disassemble frame display and confirm visually.	Adjust or replace interfering structures.	

Problems	Symptom	Causes	Checks	Measures	Remarks
Defective display button.	Buzzer does not sound and buttons do not operate.	Trouble mode indication.	Check trouble diagnosis function.	Repair troubles	Refer to mode indication in function explanations.
Door Buzzer	Buzzer continuously rings or door opening alarm does not work.	Defective connecting lead wire from main PCB to door switch.	Check lead wire associated with door switch.	Repair lead wire.	Check model with dispenser.
		Defective freezer compartment door switch parts.	Refer to door switch in parts repair guide.	Replace Freezer compartment door switch.	
Bad water/ice dispenser.	Ice and water are not dispensed.	Defective connecting lead wire from Main PCB to lever switch.	Check Lead Wire associated with lever switch with a tester.	Repair lead wire.	
		Defective lever switch parts	Refer to door switch in parts repair guide.	Replace lever switch.	
		Defective photo coupler IC parts.	Check voltage change at photo coupler output terminals with lever switch pressed. It is OK if voltage change is between 0V - 5V.	Replace photo coupler IC or PCB.	
		Defective relay associated with ice dispenser (gears motor, cube, and dispenser solenoid).	Check relay (RY4, RY5, RY12) with a tester.	Replace defective relay.	
		Defective parts associated with ice dispenser (gears motor, cube, and dispenser solenoid).	Check resistance of parts with a tester.	Replace defective parts.	
		Defective relay associated with water dispenser.	Check relay (RY7) with a tester	Replace defective relay.	
		Defective parts associated with water dispenser.	Check resistance of parts with a tester.	Replace defective parts.	

3. Sealed System Heavy Repair
Summary of Heavy Repair

Process	Contents	Tools
		
	- Cut charging pipe ends and discharge refrigerant from drier and compressor.	Filter, side cutters
	<ul style="list-style-type: none"> - Use R134a oil and refrigerant for compressor and drier - Confirm N₂ sealing and packing conditions before use. Use good one for welding and assembly. - Weld under nitrogen gas atmosphere. (N₂ gas pressure: 1.42-2.85 psi). - Repair in a clean and dry place. 	Pipe Cutter, Gas welder, N ₂ gas
	<ul style="list-style-type: none"> - Evacuate for more than forty minutes after connecting manifold gauge hose and vacuum pump to high (drier) and low (compressor refrigerant discharging parts) pressure sides. - Evacuation Speed: 113 liters/minute. 	Vacuum pump R134a exclusively, Manifold gauge.
	<ul style="list-style-type: none"> - Weigh and control the allowance of R134a charging canister in a vacuum conditions to be ± 0.176 oz with electronic scales and charge through compressor inlet (Charge while compressor operates). - Weld carefully after pinching off the inlet pipe. 	R134a exclusive charging canister (mass cylinder), refrigerant R134a manifold gauge, electronic scales, pinch-off plier, gas welding machine
	<ul style="list-style-type: none"> - Check leak at weld joints. <ul style="list-style-type: none"> □ Minute leak : Use electronic leak detector □ Big leak : Check visually. Note: Do not use soapy water for check. - Check cooling capacity <ul style="list-style-type: none"> Check radiator manually to see if warm. Check hot line pipe manually to see if warm. Check frost formation on the whole surface of the evaporator. <p>NOTE: Some tools should be reserved for use with R134a exclusively. Tools and gauges used with R134a should be kept clean and stored separately from other tools to avoid cross- contamination by other refrigerants and lubricants.</p>	Electronic Leak Detector, Driver (Ruler).
	<ul style="list-style-type: none"> - Remove flux from the silver weld joints with soft brush or wet rag. Flux may be the cause of corrosion and leaks. - Clean R134a exclusive tools and store them in a clean tool box or in their place. 	Copper brush, Rag, Tool box
	- Installation should be conducted in accordance with the standard installation procedure. Leave space of more than 5 cm (2 inches) from the wall for compressor compartment cooling fan mounted model.	

Precautions during heavy repair

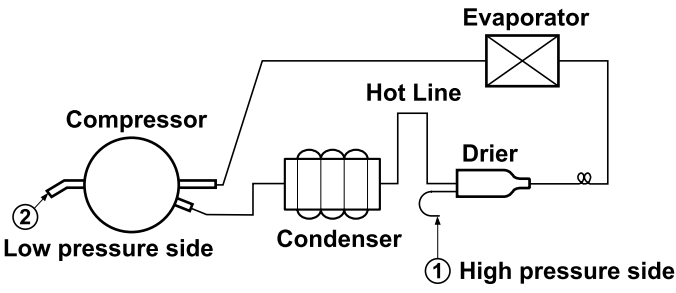
Items	Precautions
1. Use of tools.	1) Use special parts and tools for R134a.
2. Recovery of refrigerant	<p>1) Continue to recover the refrigerant for more than 5 minutes after turning the refrigerator off.</p> <p>2) Install a piercing type valve on the high pressure line (drier side). Then use the appropriate recovery equipment to recover the refrigerant from the system. When the refrigerant has been recovered, install a piercing type valve on the low pressure side. IT IS IMPORTANT TO OPEN THE SYSTEM IN THIS ORDER TO KEEP THE OIL FROM BEING FORCED OUT.</p> <p>The use of piercing type valves will allow future servicing and eliminates the possibility of a defective pinch off.</p>  <p>The diagram illustrates a refrigeration cycle with the following components and connections: <ul style="list-style-type: none"> Compressor: Located on the left, with a circled '2' indicating the low pressure side connection point. Condenser: A coil of pipes connected to the compressor. Hot Line: A vertical pipe connecting the condenser to the drier. Drier: A cylindrical component with a circled '1' indicating the high pressure side connection point. Evaporator: A rectangular component with an 'X' inside, connected to the drier and the condenser. </p>
3. Replacement of drier.	1) Be sure to replace drier with R134a only when repairing pipes and injecting refrigerant.
4. Nitrogen blowing welding.	1) Use pressurized nitrogen to prevent oxidation inside the piping. (Nitrogen pressure : 1.42 - 2.85 psi)
5. Others.	<p>1) Only nitrogen or R134a should be used when cleaning the inside of piping of the sealed system.</p> <p>2) Check leakage with an electronic leakage tester.</p> <p>3) Be sure to use a pipe cutter when cutting pipes.</p> <p>4) Be careful not the water let intrude into the inside of the cycle.</p>

3-4. Practical Work For Heavy Repair

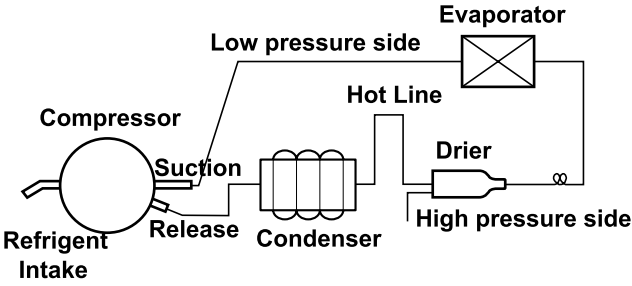
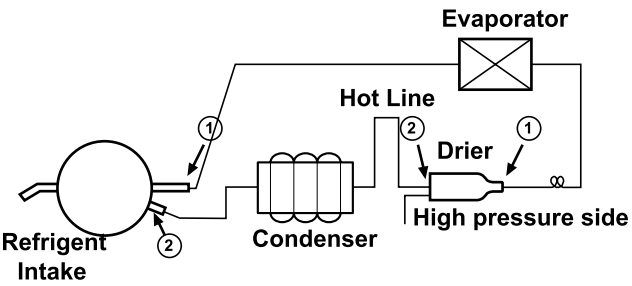
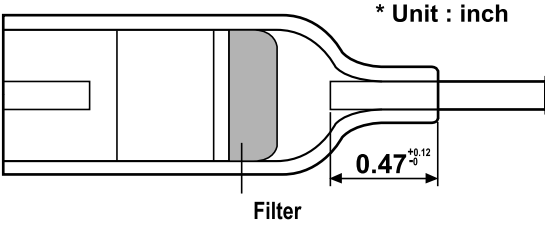
Items	Precautions
<p>1. Removal of residual refrigerant.</p>	<div style="display: flex; justify-content: space-between; align-items: flex-start;"> <div style="text-align: center;">  </div> <div style="width: 20%;"> <p>KEY POINT Observe the sequence for removal of refrigerant. (If not, compressor oil may leak.)</p> </div> </div> <p>1) Continue to recover the refrigerant for more than 5 minutes after turning the refrigerator off.</p> <p>2) Install a piercing type valve on the high pressure line (drier side). Then use the appropriate recovery equipment to recover the refrigerant from the system. When the refrigerant has been recovered, install a piercing type valve on the low pressure side. IT IS IMPORTANT TO OPEN THE SYSTEM IN THIS ORDER TO KEEP THE OIL FROM BEING FORCED OUT.</p> <p>The use of piercing type valves will allow future servicing and eliminates the possibility of a defective pinch off.</p>
<p>2. Nitrogen blowing welding.</p>	<div style="display: flex; justify-content: space-between; align-items: flex-start;"> <div style="text-align: center;">  </div> <div style="width: 20%;"> <p>KEY POINT Welding without nitrogen blowing produces oxidized scales inside a pipe, which affect performance and reliability of a product.</p> </div> </div> <p>When replacing a drier: Weld ① and ② parts by blowing nitrogen (1.42-2.85 psi) to high pressure side after assembling a drier.</p> <p>When replacing a compressor: Weld ① and ② parts by blowing nitrogen to the low pressure side.</p> <p>Note) For other parts, nitrogen blowing is not necessary because it does not produce oxidized scales inside pipe because of its short welding time.</p>
<p>3. Replacement of drier.</p>	<div style="display: flex; justify-content: space-between; align-items: flex-start;"> <div style="text-align: center;">  </div> <div style="width: 20%;"> <p>KEY POINT Be sure to check the inserted length of capillary tube when it is inserted. (If inserted too far, the capillary tube will be blocked by the filter.)</p> </div> </div> <p>Inserting a capillary tube Measure distance with a ruler and put a mark(0.47^{+0.12}/₋₀)on the capillary tube. Insert tube to the mark and weld it</p>

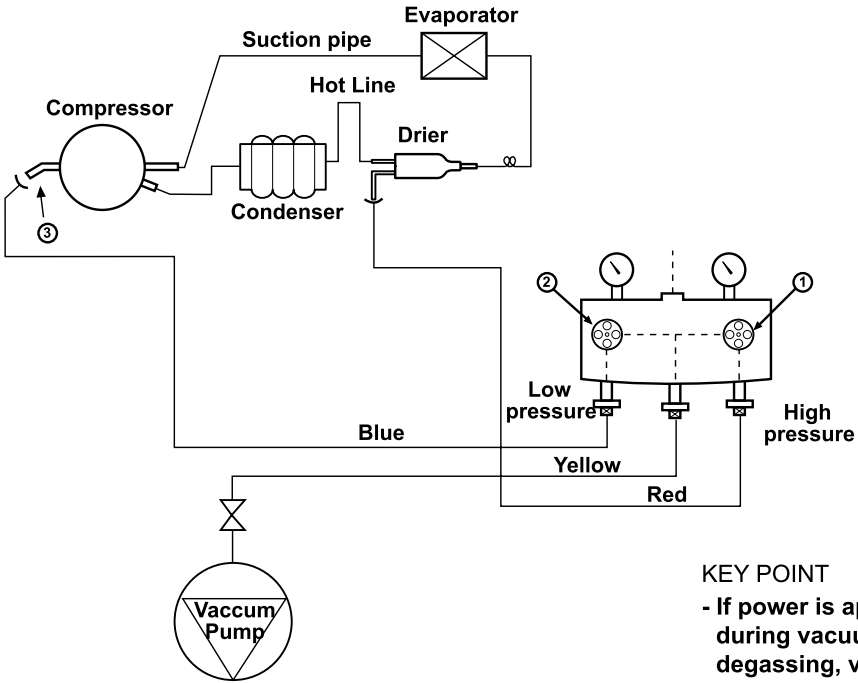
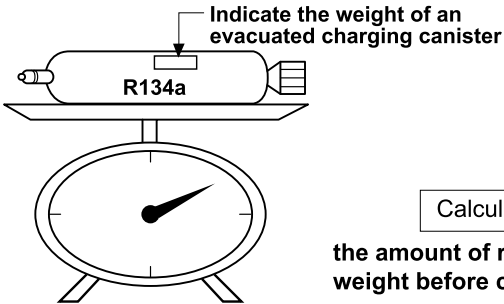
Items	Precautions
<p>4. Vacuum degassing.</p>	<div style="text-align: center;">  </div> <p>Pipe Connection Connect the red hose to the high pressure side and the blue hose to the low pressure side.</p> <p>Vacuum Sequence Open valves ① and ② and evacuate for 40 minutes. Close valve ①.</p> <p style="text-align: right;">KEY POINT - If power is applied during vacuum degassing, vacuum degassing will be more effective. - Run the compressor while charging the system. It is easier and works better.</p>
<p>5. Refrigerant charging.</p>	<p>Charging sequence</p> <ol style="list-style-type: none"> 1) Check the amount of refrigerant supplied to each model after completing vacuum degassing. 2) Evacuate charging canister with a vacuum pump. 3) Measure the amount of refrigerant charged. <ul style="list-style-type: none"> - Measure the weight of an evacuated charging canister with an electronic scale. - Charge refrigerant into a charging canister and measure the weight. Calculate the weight of refrigerant charged into the charging canister by subtracting the weight of an evacuated charging canister. <div style="text-align: center;">  </div> <p style="text-align: center;">Calculation of amount of refrigerant charged</p> <p>the amount of refrigerant charged = weight after charging - weight before charging (weight of an evacuated cylinder)</p> <p style="text-align: right;">KEY POINT - Be sure to charge the refrigerant at around 25°C [77°F]. - Be sure to keep -5g in the winter and +5g in summer.</p>

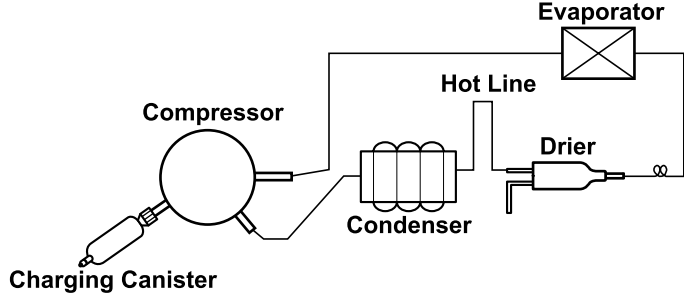
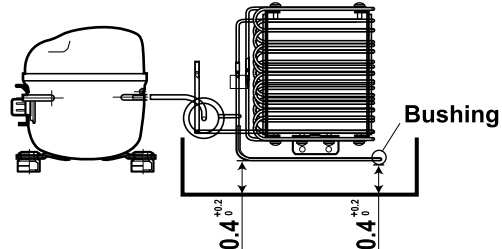
Items	Precautions
	 <p>4) Refrigerant Charging Charge refrigerant while operating a compressor as shown above.</p> <p>5) Pinch the charging pipe with a pinch-off plier after completion of charging.</p> <p>6) Braze the end of a pinched charging pipe with copper brazer and make a gas leakage test on the welded parts.</p>
6. Gas-leakage test	* Test for leaks on the welded or suspicious area with an electronic leakage tester.
7. Pipe arrangement in each cycle	<p>When replacing components, be sure each pipe is replaced in its original position before closing the cover of the mechanical area.</p> 

3-5. Standard Regulations For Heavy Repair

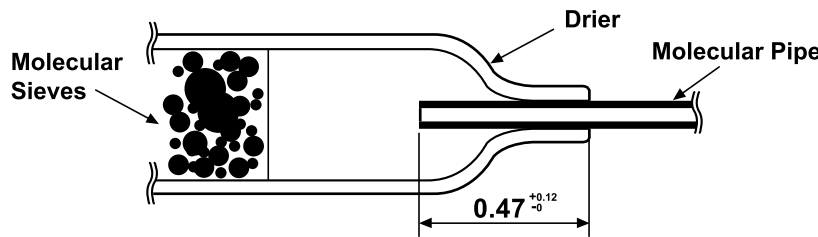
<ol style="list-style-type: none"> 1) Observe the safety precautions for gas handling. 2) Use JIG (or a wet towel) in order to prevent electric wires from burning during welding. (In order to prevent insulation break and accident.) 3) The inner case will melt and the insulation will burn. 4) The copper piping will oxidize. 5) Do not allow aluminum and copper pipes to touch. (In order to prevent corrosion.) 6) Observe that the inserted length of a capillary tube into a drier should be $0.47^{+0.12}_{-0}$ mm.  <ol style="list-style-type: none"> 7) Make sure that the inner diameter is not distorted while cutting a capillary tube. 8) Be sure that the suction pipe and the filling tube should not be substituted each other during welding. (High efficiency pump.)
--

3-6. Brazing Reference Drawings

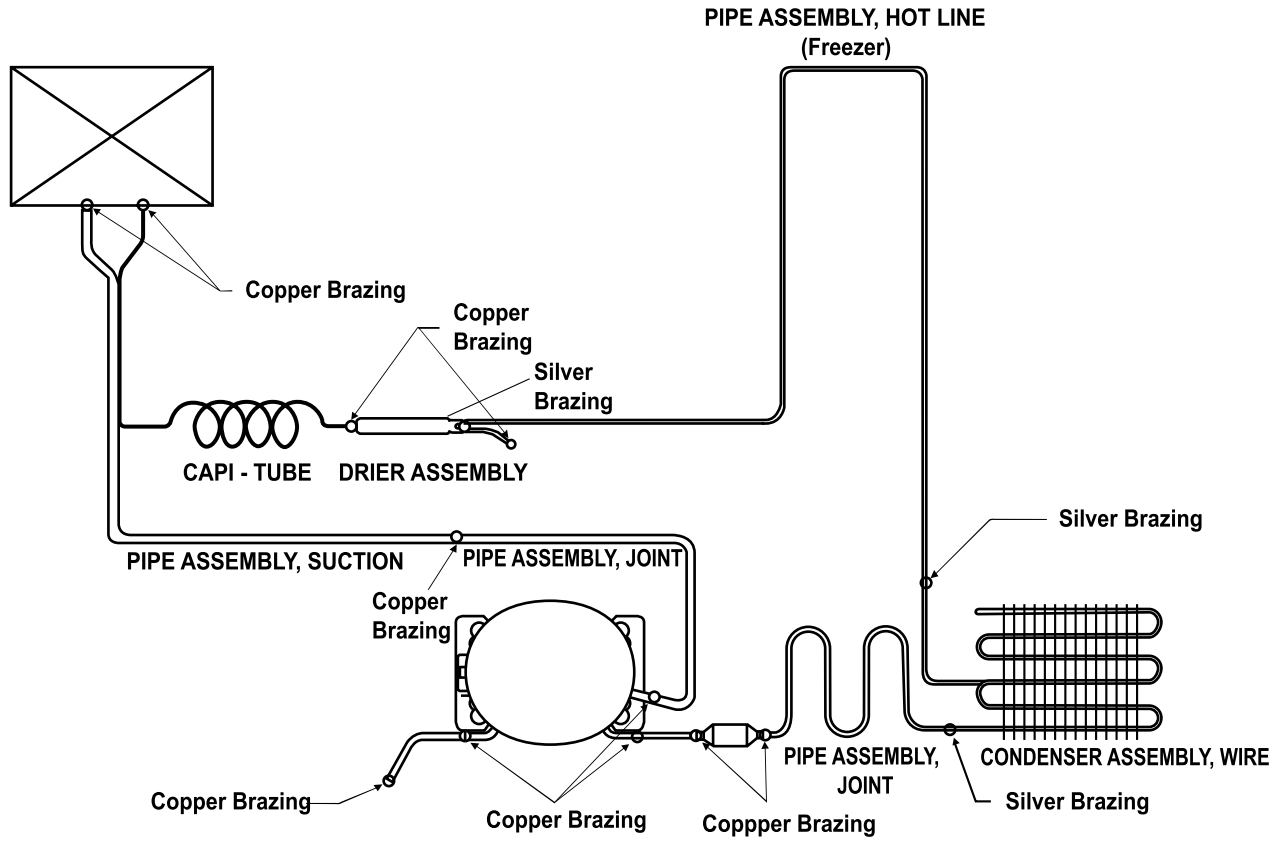

4. HOW TO DEAL WITH CLAIMS

4-1. Sound

Problems	Checks and Measures
Hiss	<ul style="list-style-type: none"> - Explain general principles of sounds. <ul style="list-style-type: none"> • All refrigerators make noises when they run. The compressor and fan produce sounds. There is a fan in the freezer compartment which blows cool air to freezer and refrigerator compartments. Hissing is sounds are heard when the air passes through the narrow holes into the freezer and refrigerator compartments. - Cooling Fan sound in the compressor compartment. <ul style="list-style-type: none"> • There is a fan on the back of the refrigerator which cools the compressor compartment. If there is a small space between the refrigerator and the wall, the air circulation sounds may be noticeable. - Noise of Compressor. <ul style="list-style-type: none"> • This operating sound happens when the compressor compresses the refrigerant. The compressor rotates at 3600 RPM. The sound of compressor. Bigger refrigerators make more noise than small ones
Click	<ul style="list-style-type: none"> - Explain the principles of temperature change. <ul style="list-style-type: none"> • The sounds happens when pipes and internal evaporator in the refrigerator compartment expand and contract as the temperature changes during the refrigerator operation. This sound also happens during defrosting, twice a day, when the ice on the evaporator melts.
Clunk	<ul style="list-style-type: none"> - Explain that it comes from the compressor when the refrigerator starts. <ul style="list-style-type: none"> • When the refrigerator operates, the piston and motor in the compressor rotate at 3600 RPM. This sound is caused by the vibration of motor and piston when they start and finish their operation. This phenomenon can be compared with that of cars. When an automobile engine starts, it is loud at first but quiets down quickly. When the engine stops, so does the vibration.
Vibration	<ul style="list-style-type: none"> - Check the sound whether it comes from the pipes vibration and friction. <ul style="list-style-type: none"> • Insert bushing or leave a space between pipes to avoid the noise. • Fix the fan blade if it is hitting on the shroud • Fix the drip tray if it is loosened. - Sound depends on the installation location. <ul style="list-style-type: none"> • Sound becomes louder if the refrigerator is installed on a wooden floor or near a wooden wall. Move it to the another location. • If the refrigerator is not leveled properly, a small vibration can make a loud sound. Please adjust the level of the refrigerator.

Problems	Checks and Measures
<p>Sounds of water flowing</p>	<ul style="list-style-type: none"> - Explain the flow of refrigerant. • When the refrigerator stops, the water flowing sound happens. This sound happens when the liquid or vapor refrigerant flows from the evaporator to compressor.
<p>Click</p>	<ul style="list-style-type: none"> - Explain the characteristics of moving parts. • This noise comes from the MICOM controller's switch on the top of the refrigerator when it is turned on and off.
<p>Noise of Icemaker operation (applicable to model with Icemaker).</p> <ul style="list-style-type: none"> - Noise produced by ice dropping and hitting ice bin. - Noise from motor sounds Hiss. 	<ul style="list-style-type: none"> - Explain the procedure and principles of Icemaker operation. • The automatic icemaker continuously cycles through water supply → icemaking → ice ejection→ repeat. When water is dispensed, the water supply valve in the mechanical area makes hissing sounds and you can hear the water flow. When water freezes, you can hear clicking. When ice is ejected, you can hear the motor run, the tray twist, and ice breaking and falling into the bin.
<p>Noise when dispensing water.</p>	<ul style="list-style-type: none"> - Explain the principles of water supplied to dispenser. • When the water supply button in the dispenser is pressed, the water supply valve in the compressor compartment opens and let the water flow to the water tank in the lower part of the refrigerator compartment. The water is dispensed by this pressure. When this happens, motor sound and water flowing sound are heard.
<p>Noise when dispensing ice.</p>	<ul style="list-style-type: none"> - Explain the principles of ice supply and procedure of crushed icemaking in a dispenser. • When ice cube button is pressed, ice stored in the ice bin is moved by an auger and dispensed. If crushed ice button is pressed, the ice cube is crushed. When this happens, ice crushing and hitting ice bin sounds are heard.

4-2. Measures for Symptoms on Temperature

Problems	Checks and Measures
Refrigeration is weak.	<p>Check temperature set in the temperature control knob.</p> <ul style="list-style-type: none"> • Refrigerator is generally delivered with the button set at normal use (MID). But customer can adjust the temperature set depending on their habit and taste. If you feel the refrigeration is weak, then set the temperature control button at strong position. If you adjust the button in the freezer compartment as well, the refrigeration is stronger than adjusting refrigerator only.
The food in the chilled drawer is not frozen but defrosted	<p>The chilled drawer does not freeze food.</p> <ul style="list-style-type: none"> • Use chilled drawer for storing fresh meat or fish for short periods. For storing for a long periods or freezing food, use a freezer compartment. It is normal that frozen foods thaw above the freezing temperature (in the chilled drawer).
Refrigerator water is not cool.	<p>Check the water storage location.</p> <ul style="list-style-type: none"> • If water is kept in the door rack, move it to a refrigerator shelf. It will then become cooler.
Ice cream softens.	<p>Explain the characteristics of ice cream.</p> <ul style="list-style-type: none"> • Because of its ingredients, ice cream melts beginning at 18°F (-8°C). Ice cream will still be soft when ice is still frozen solid. Consequently it should be stored on a lower shelf in the freezer and not in the door. • Store ice cream in a cold place or set the temperature control button of a freezer at strong position.
Refrigeration is too strong.	<p>Check the position of temperature control button.</p> <ul style="list-style-type: none"> • Check if refrigeration is strong in whole area of the refrigerator or partly near the outlet of the cooling air. If it is strong in whole area, set the control button at weak. If it is strong only near the outlet of cool air, keep food (especially damp foods and easily frozen foods) away from the outlet.
Vegetables are frozen.	<p>Check the vegetables storage.</p> <ul style="list-style-type: none"> • If vegetables are stored in the refrigerator shelf or chilled drawer instead of vegetable drawer, they will be frozen. Set the control button at weak if they are also frozen in the vegetable drawer.
The food stored at inside of the shelf freezes even the control button is set at MID	<p>Check if food is stored near the outlet of the cooling air.</p> <ul style="list-style-type: none"> • The temperature at cooling air outlet is always below the freezing point. Do not store food near the outlet of the cooling air as it block the air circulation. Do not block the outlet. If the outlet of the cooling air is blocked, the refrigerator compartment will not be cooled.

4-3. Odor and Frost

Problems	Checks and Measures
<p>Odor in the refrigerator compartment.</p>	<p>Explain the basic principles of food odor.</p> <ul style="list-style-type: none"> • Each food has its own particular odor. Therefore it is impossible to prevent or avoid food odor completely when food is stored in the completely sealed refrigerator compartment. <p>Check the temperature control button and set at STRONG.</p> <ul style="list-style-type: none"> • Clean inside of the refrigerator with detergent and remove moisture. Dry inside the refrigerator by opening the door for about 3 or 4 hours and then set the temperature control button at STRONG.
<p>Frost in the freezer compartment</p>	<p>Explain the basic principles of frost formation.</p> <ul style="list-style-type: none"> • The main causes for frosting: <ul style="list-style-type: none"> - Door was left open. - Air penetration through the gasket - Too frequent door opening. (parties. etc.) - Hot foods are stored before they are cooled down. The temperature of freezer is -19°C [-2.2°F]. if temperature is set at MID . If hot air comes into the refrigerator, fine frost forms as cold air mixes with hot air. If this happens quite often, much frost forms inside of the refrigerator. If the door is left open in Summer, ice may form inside of the refrigerator.
<p>Frost in ice tray.</p>	<p>Explain basic principles of frost formation.</p> <ul style="list-style-type: none"> • When ice tray with full of water is put into a freezer compartment, the water evaporates. If cool air fan operates, the moisture attached to the jaw (protruded part) of ice mold will freeze and form frost. If warm water was put into the ice mold, the situation will become worse.

4-5. Others

Problems	Checks and Measures
<p>The refrigerator case is hot.</p>	<p>Explain the principles of radiator.</p> <ul style="list-style-type: none"> •The radiator pipes are installed in the refrigerator case and partition plate between the refrigerator and the freezer compartment in order to prevent condensation formation. Particularly in summer or after installation of refrigerator, it may feel hot but it is normal. If there is not enough space to dissipate heat, it can be hotter due to lack of heat radiation. Please install a refrigerator in a well-ventilated place and leave the clearance between refrigerator and wall
<p>Small holes in door liner</p>	<p>Explain that the small holes are to release pressure during the manufacturing process.</p> <ul style="list-style-type: none"> •It helps to make a better fit when plastic is vacuum molded and formed and when foam insulation is blown in under pressure.
<p>Electric bills are too much.</p>	<p>Explain that the hole is to allow the air to escape when vacuum forming plastic parts and pumping foam insulation into cavities.</p> <p>There are small holes in the plastic liner of some parts of the refrigerator. These holes allow plastic parts to be injection molded and vacuum formed by allowing air bubbles to be expelled. They also allow foam insulation to be pumped into cavities where air bubbles may build up.</p>
<p>Condensation on the inside wall of the refrigerator compartment and the cover of properly vegetable drawer.</p>	<p>Explain how to store foods</p> <ul style="list-style-type: none"> • Condensation forms when refrigerator is installed at damp area, door is frequently opened, and wet foods are not stored in the air tight container or wrapped. Be sure to store wet foods in airtight containers or securely covered in plastic wrap.
<p>When is the power connected?</p>	<p>When should the power be connected ?</p> <ul style="list-style-type: none"> • You can connect the power immediately after installation. However, if the refrigerator was laid flat before or during installation, you must stand it upright for 6 hours before plugging it in. This allows the refrigerant oils to return to the sump in the compressor. If you operate the refrigerator before the oil has had a chance to settle, you could damage the compressor.
<p>Door does not open properly.</p>	<p>Refrigerator compartment door does not open properly.</p> <ul style="list-style-type: none"> •When the door is opened, warm air gets into the refrigerator. As it cools, it sometimes forms a slight vacuum. Pull the door gently to open it. This is normal and causes no harm. <p>When the refrigerator compartment door is opened and closed, the freezer compartment door moves up and down.</p> <ul style="list-style-type: none"> •When one of the doors is closed too forcefully, it can create a slight compression and cause the other door to open slightly. This is normal. Close the door lightly to eliminate this problem. If the doors are adjusted properly (the refrigerator is leveled properly,) the doors will fall closed by themselves. <p>Door opens too easily.</p> <ul style="list-style-type: none"> • There is a magnet in the gasket so it closes securely without a gap. It can be held open easily if something is in the way and obstructs the door's closing. <p>A door does not close properly.</p> <ul style="list-style-type: none"> • If the refrigerator is not properly leveled, the doors will not close easily. Adjust the level using the leveling screws under the front of the refrigerator.

9. HOW TO DISASSEMBLY AND ASSEMBLE

1. DOOR

- 1) Remove lower cover and then disconnect water supply tube in the lower part of freezer door.
Remove clip.
Pull out tube while pressing collets ① and disassemble it ②.

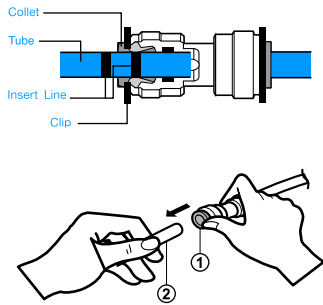

Disconnecting the tube under the door causes about 1.5 liters water to flow out. Please put up a big container to prevent it.

- 2) Remove the freezer door.
 - (1) Loosen hinge cover screw of freezer door and remove cover.
Disconnect all connecting lines except grounding cord.

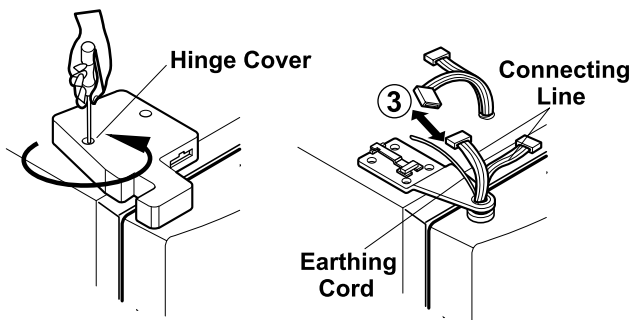

- (2) Turn hinge lever in arrow (A) direction until it is loosened and take it out in arrow (B) direction.

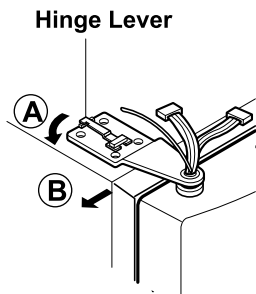

Note : • When disconnecting refrigerator door, turn hinge lever counterclockwise.

- If the hinge or bracket are bent during assembly, use two extra screws (Tap Tite M6, Left Hinge attaching screw) in the holes of the upper hinge.

- (3) Disconnect upper hinge from the hinge supporter by grasping the front part of upper hinge and lifting up the Upper Hinge Assembly in the direction of the arrow (C) and pull forward in arrow (D) direction. Be careful because the door may fall, damaging the door, the floor, or injuring you.

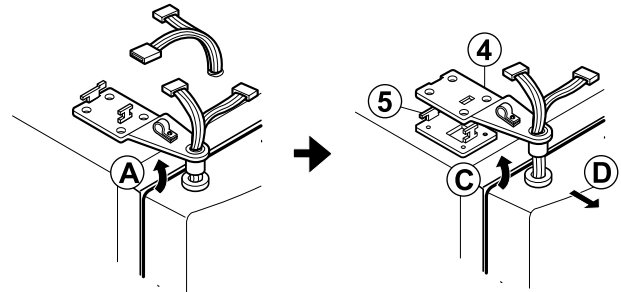

- (4) Lift up the freezer door (6) in arrow direction and disconnect the door from the lower hinge (7). Don't pull the door forward.

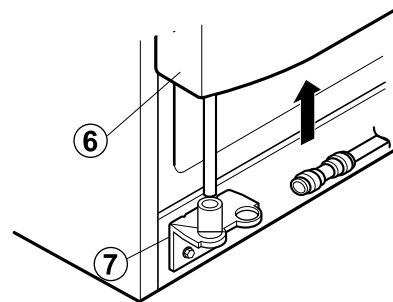

Note : • Lift up the freezer door until the water supply tube is fully removed.

- (5) Assembly is the reverse order of disassembly

3. FAN SHROUD GRILLE

- 1) Loosen one screw with a screwdriver blade.
- 2) Disassembly of an upper grille fan : Hold upper part of an upper grille fan and pull forward carefully.
- 3) Disconnect housing A of an upper grille fan from the main body.
- 4) Disassembly of a lower grille fan : Hold upper part of a lower grille fan and pull forward carefully.
- 5) Disassembly of an upper freezer shroud : Hold lower part and pull forward
- 6) Disassembly of an upper freezer shroud : Disconnect housing B
- 7) Check foam sticking conditions around a shroud, upper freezer and low freezer during assembling. if damaged, torn, or badly stuck, assemble with a new one after sealing well.

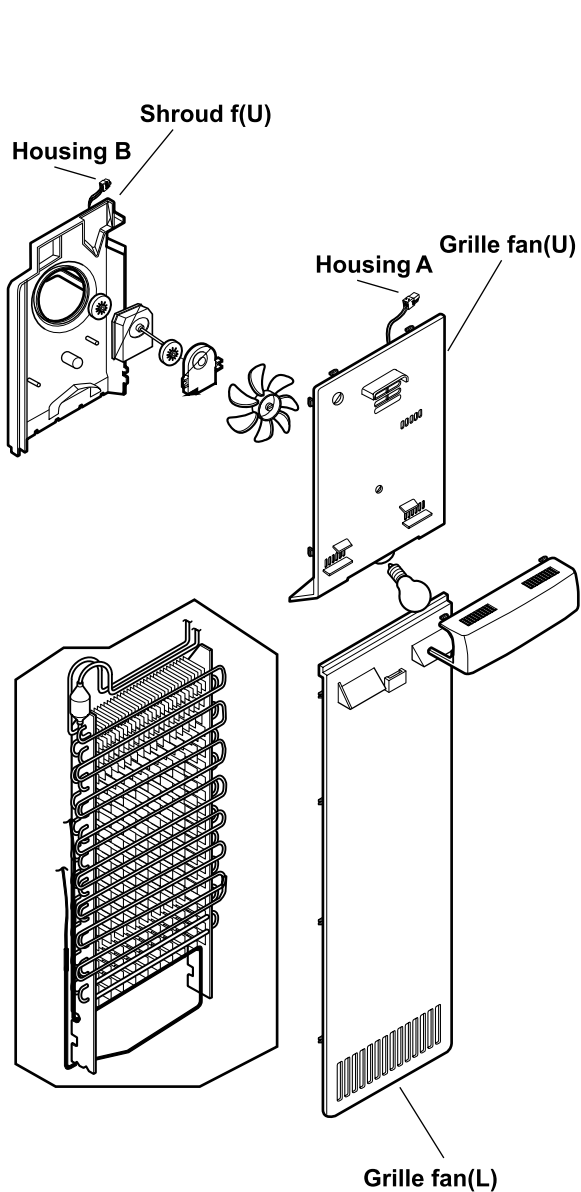

4. ICEMAKER ASSEMBLY

1. Dispenser Model

- 1) How to disassemble:
 - (1) Remove ice bin from the freezer compartment.
 - (2) Loosen two screws on the upper part of icemaker bracket.
 - (3) Disconnect icemaker bracket so that it can slide forward.
 - (4) Disconnect icemaker housing and sensor housing.
 - (5) Disconnect icemaker horizontally by pressing bracket hook part. (Doit disassemble further. The set value may be changed.)
- 2) The assembly is the reverse order of the above disassembly.

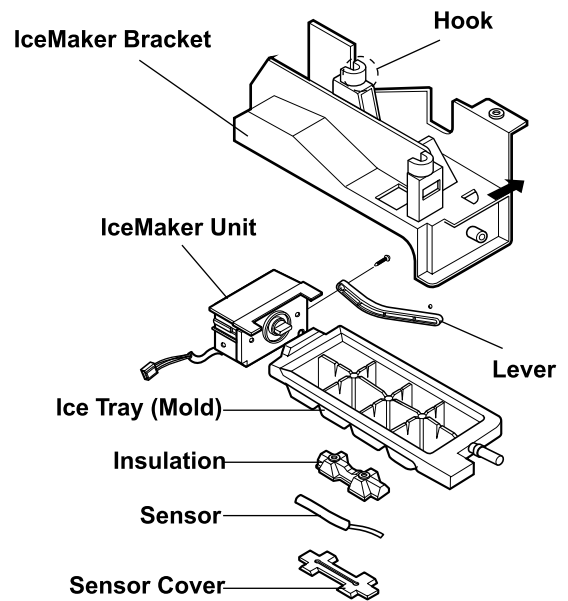

NOTE: If the ice tray (mold) is not horizontal after repair and assembly, something must be wrong. Check it and reassemble if necessary.

5. WATER-VALVE DISASSEMBLY METHOD

- 1) Turn off the power of the refrigerator (pull out the plug).
Open the F/R Door and disassemble the Lower Cover.



- 2) Lay a dry towel on the floor and get ready to pour water from the water tank.
Then press the collet to separate the tube from the connector and pour out the water until emptied.
(Refer to the label attached on Front L on how to separate the tube.)

*Disassembly

1. Remove clip. (Retire la abrazadera.)
2. Pull out tube while presiona los anillos metalcos y desmontelo.

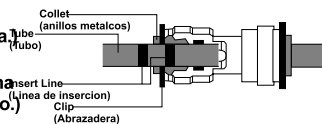

*Assembly

1. Insert tube until you can see only one line.
(Inserte el tubo hasta que solo puesa ver una linea.)
2. After inserting, pull out tube to check if it s properly inserted.
(Tras insertarlo, extraiga el tubo para comprobar si ha sido insertado correctamente.)
3. Assemcic clip. (Monte la abrazadera.)



- 3) Lock the water being supplied. Then separate the Water Connection connected to the Water Valve.



- 4) Separate the Cover Back M/C and Valve Screw



- 5) Separate the housing and pull out the valve.

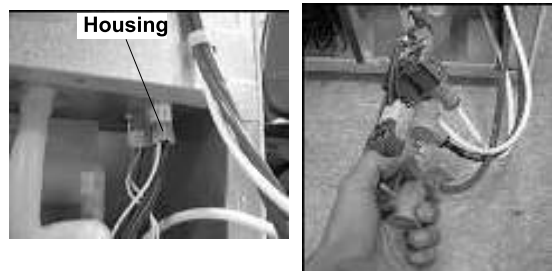

7. DISPENSER

1) Disconnect funnel and button assembly by pulling down and forward.

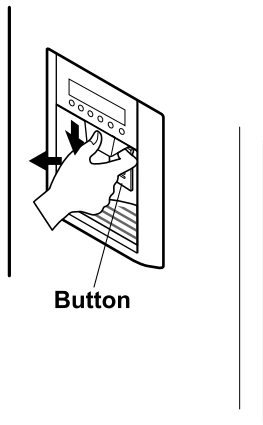

4) Loosen four screws with a phillips screwdriver and pull the Funnel Assembly to disconnect.

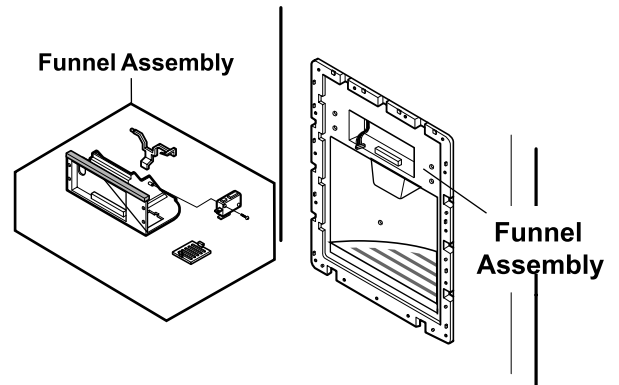

2) Remove the Display Frame moving out with both hands in one side and make the same process in the other side and pulling it forward like shows the picture.

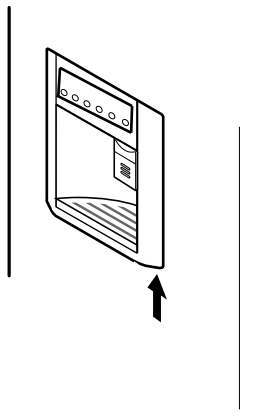

5) The Duct Cap Assembly can be disconnected if the hold lever connecting screw is loosened with a phillips driver.

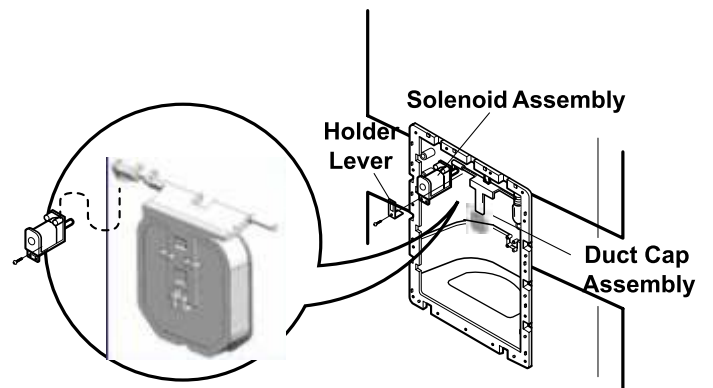

3) The Display Assembly can be connected by pressing the top of the Dispenser Cover and pushing it after separating the Display Frame from its housing.

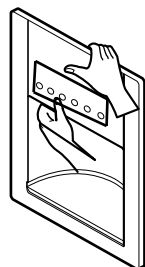

6) To install the Duct Cap Assembly, insert one end of the spring into the right hole of the dispenser lever and insert the other end into the right hole in the top part of the dispenser. Then attach the holder at the solenoid Switch.

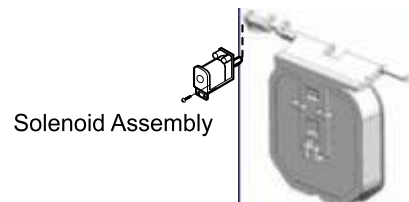

7) Dispenser Related Parts

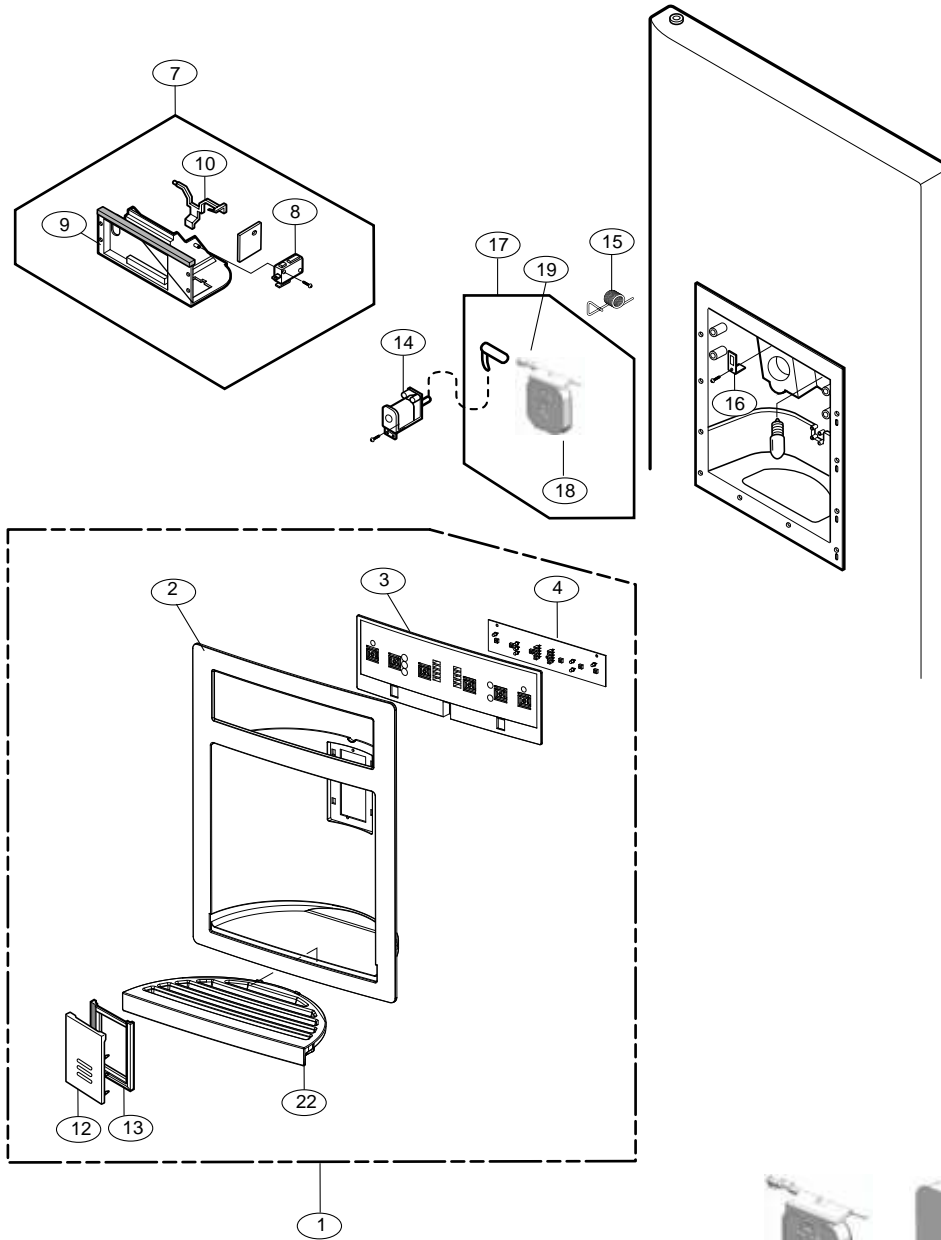

1	FRAME ASSEMBLY, DISPLAY
2	COVER, DISPENSER
3	DECO, FRAME DISPLAY
4	PWB(PCB) ASSEMBLY, DISPLAY
7	FUNNEL ASSEMBLY
8	MICRO SWITCH
9	FRAME, FUNNEL
10	LEVER(SWITCH)
11	FUNNEL
12	BUTTON LEVER
13	HOLLDER BUTTON
14	SOLENOID ASSEMBLY
15	SPRING
16	LEVER HOLDER
17	CAP ASSEMBLY, DUCT
18	CAP, DUCT
19	DISPENSER LEVER
20	FOAM, NEW
21	RUBBER, CAP
22	DECO, DRAIN



⑰ Cap Assembly, Duct Detailed Drawings

EXPLODED VIEW

FREEZER DOOR

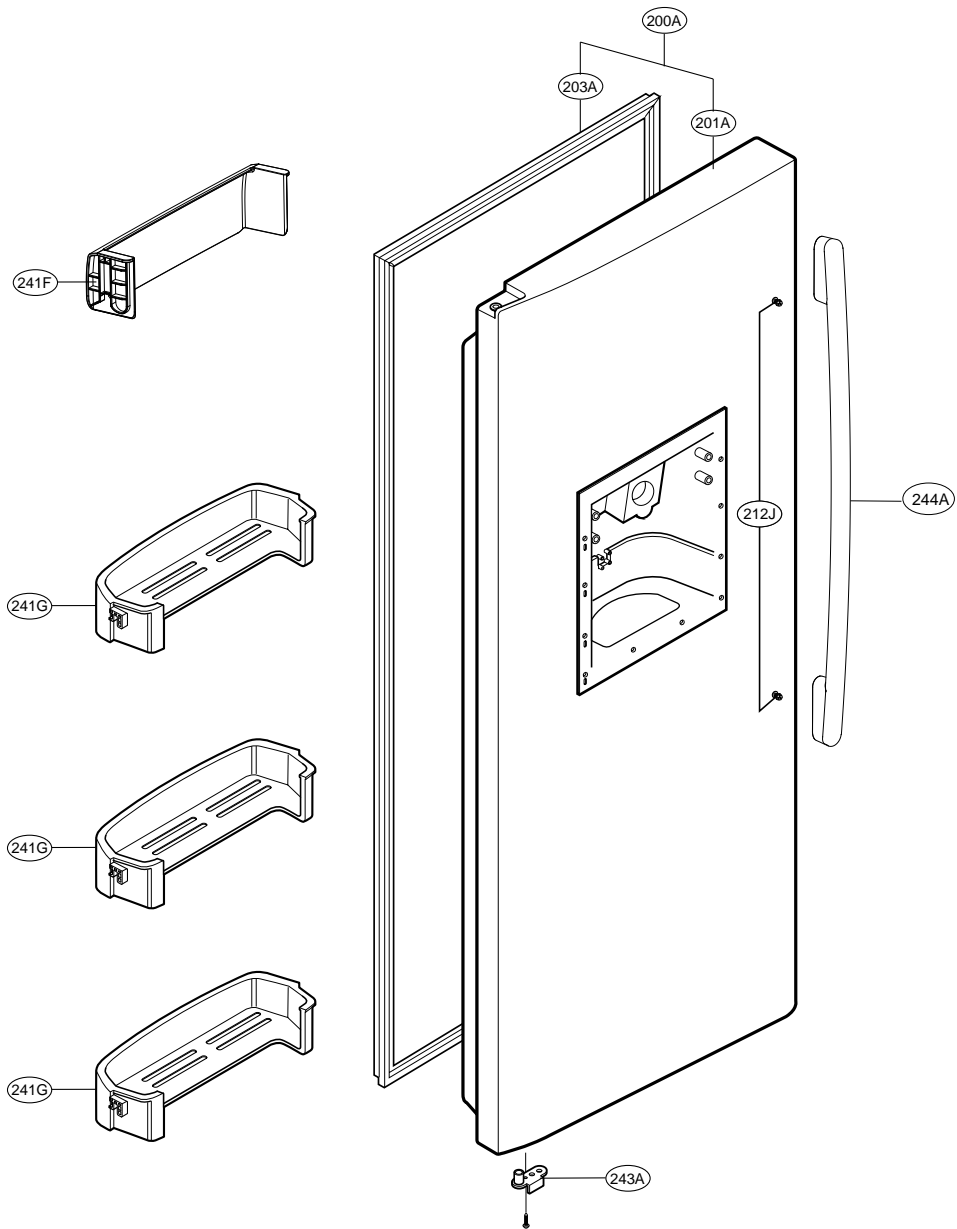

EXPLODED VIEW

REFRIGERATOR DOOR

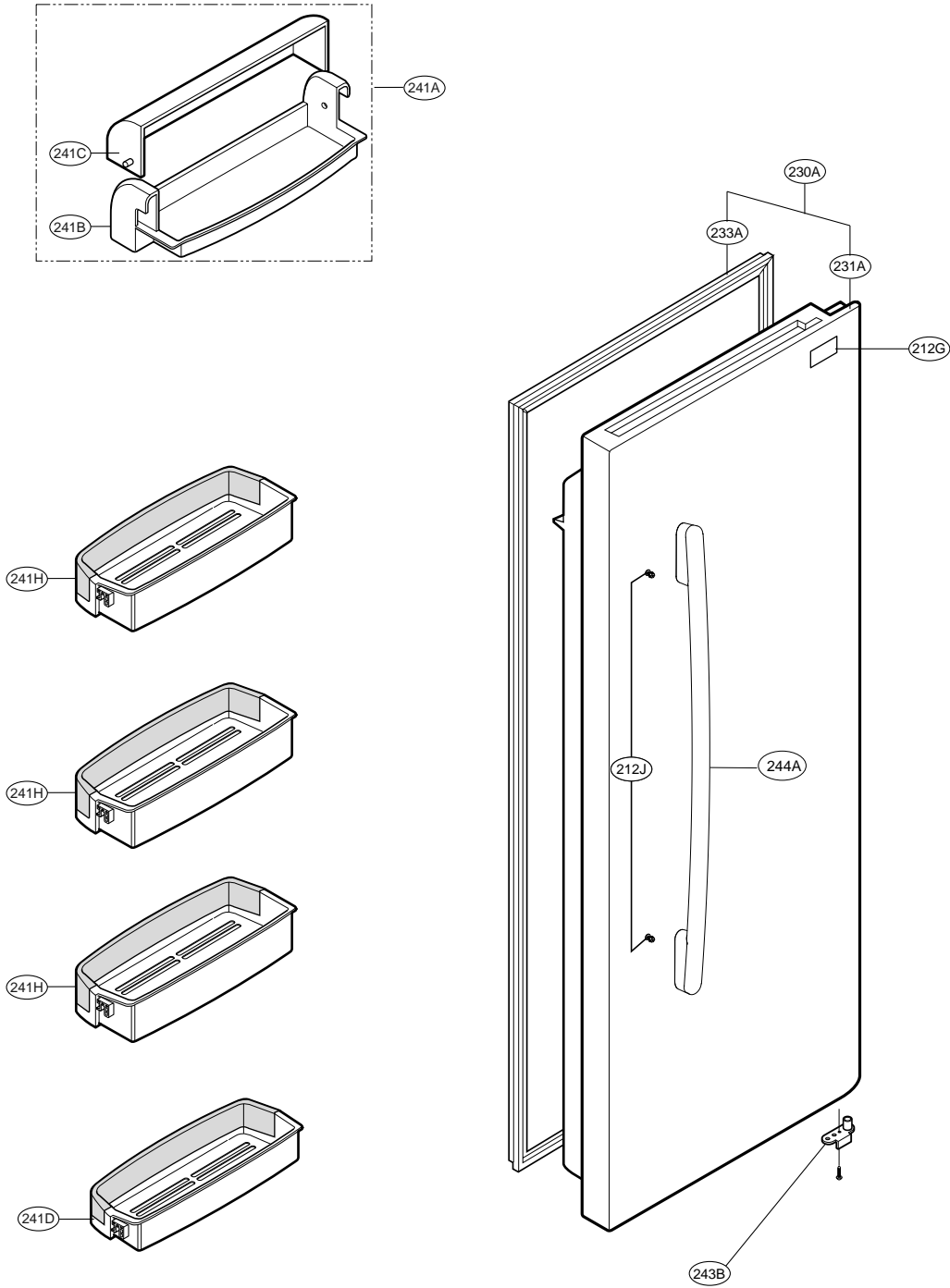

EXPLODED VIEW

REFRIGERATOR COMPARTMENT

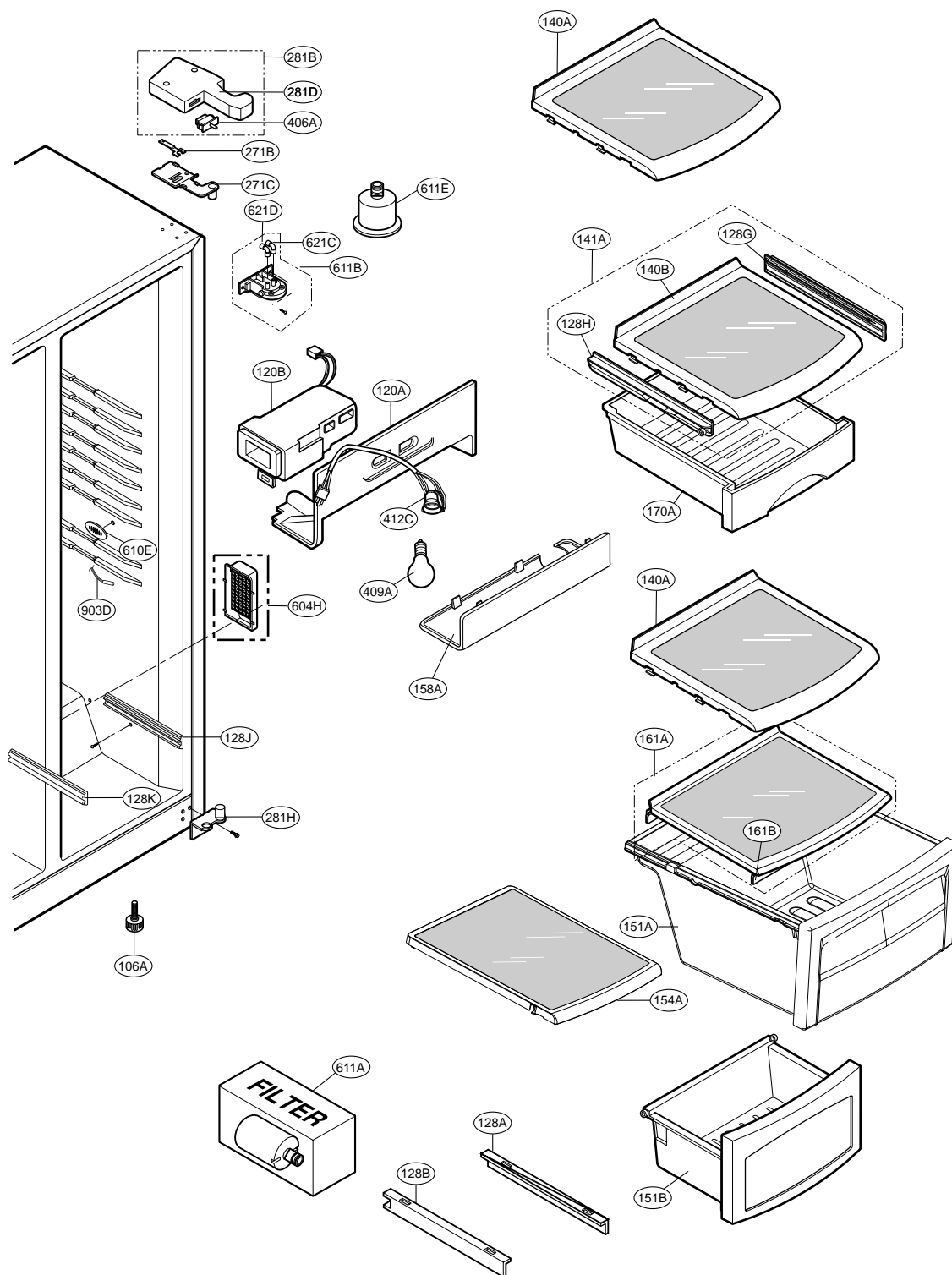

EXPLODED VIEW

ICE & WATER PARTS

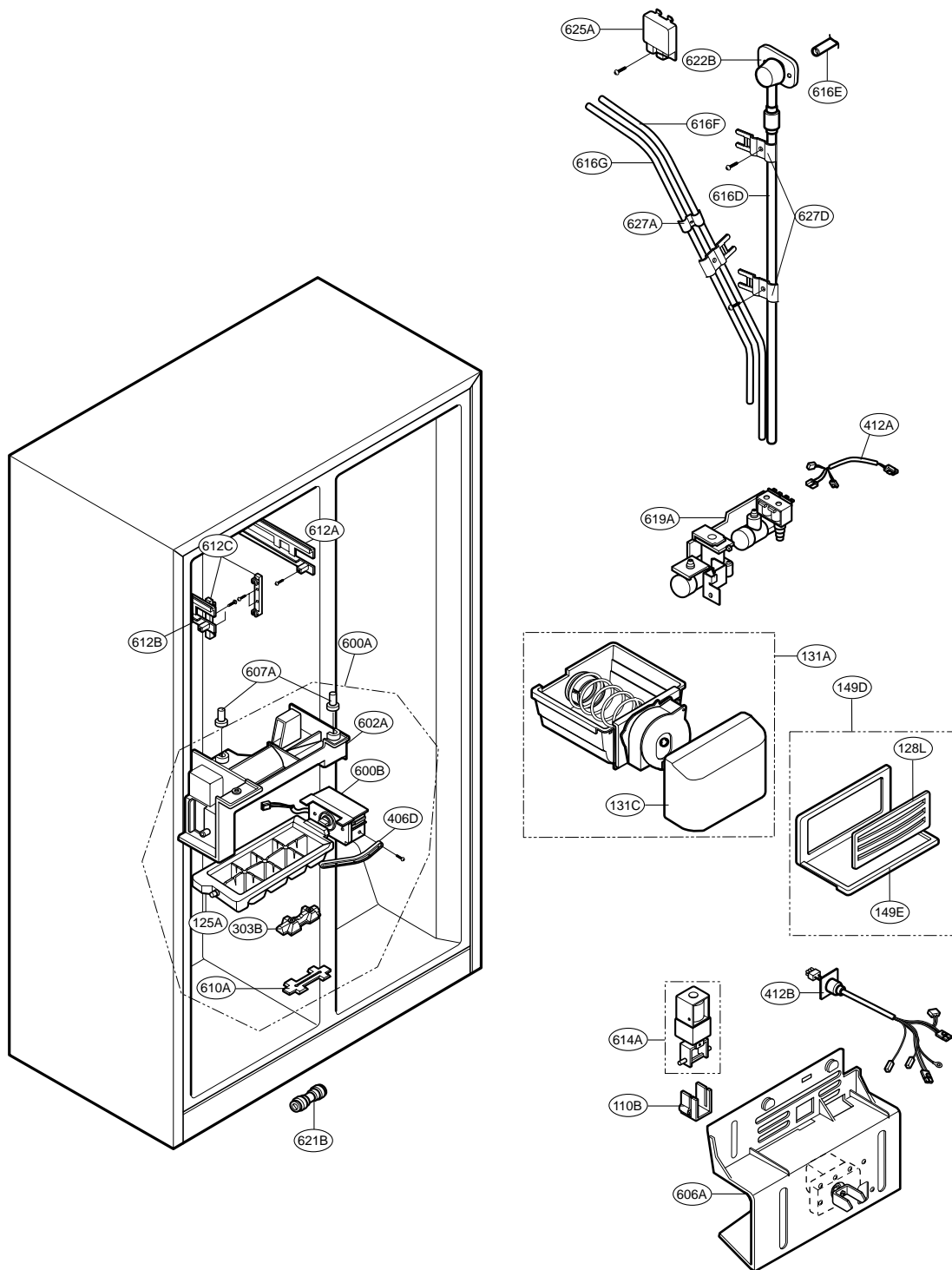

EXPLODED VIEW

MECHANICAL COMPARTMENT

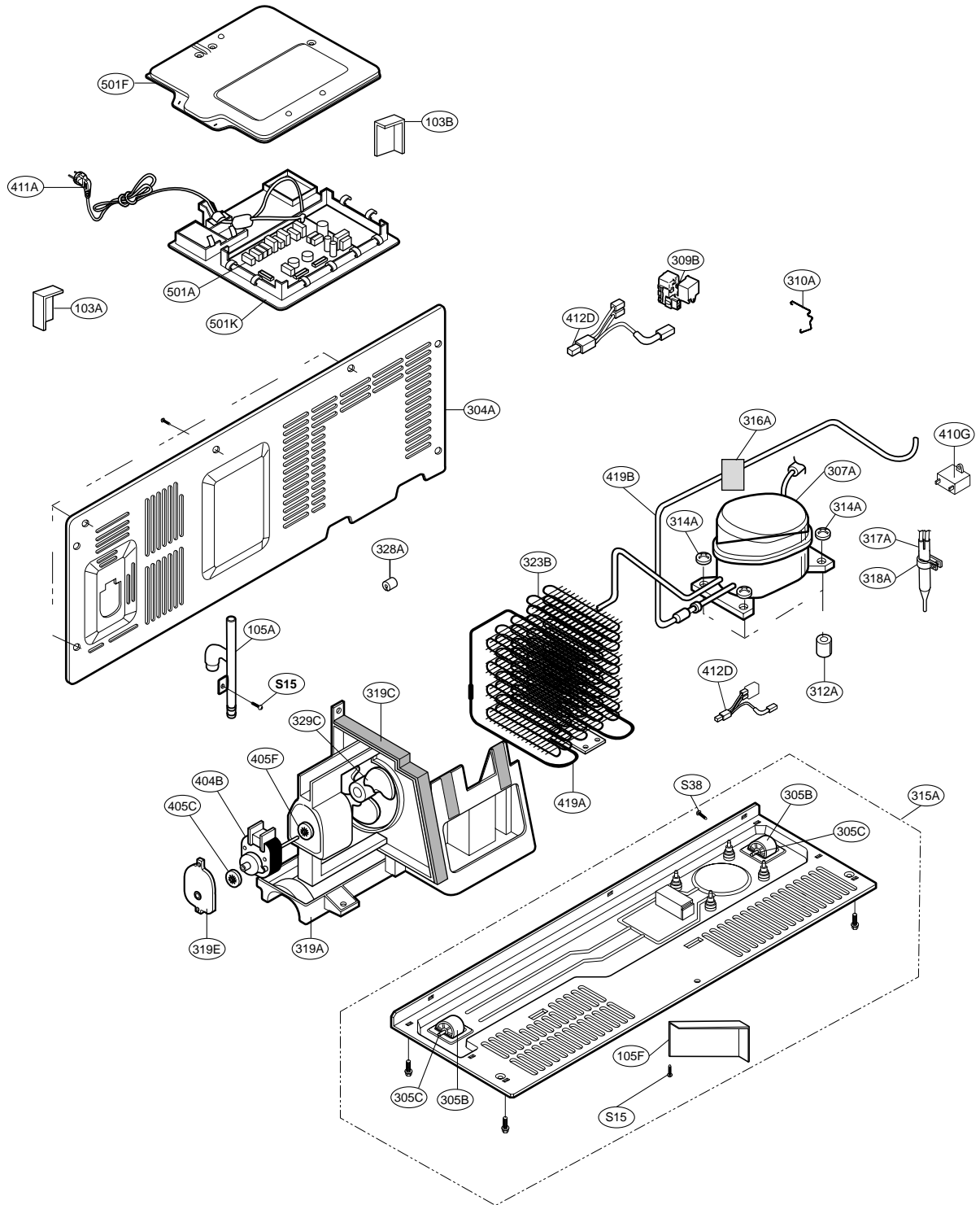

EXPLODED VIEW

DISPENSER PARTS

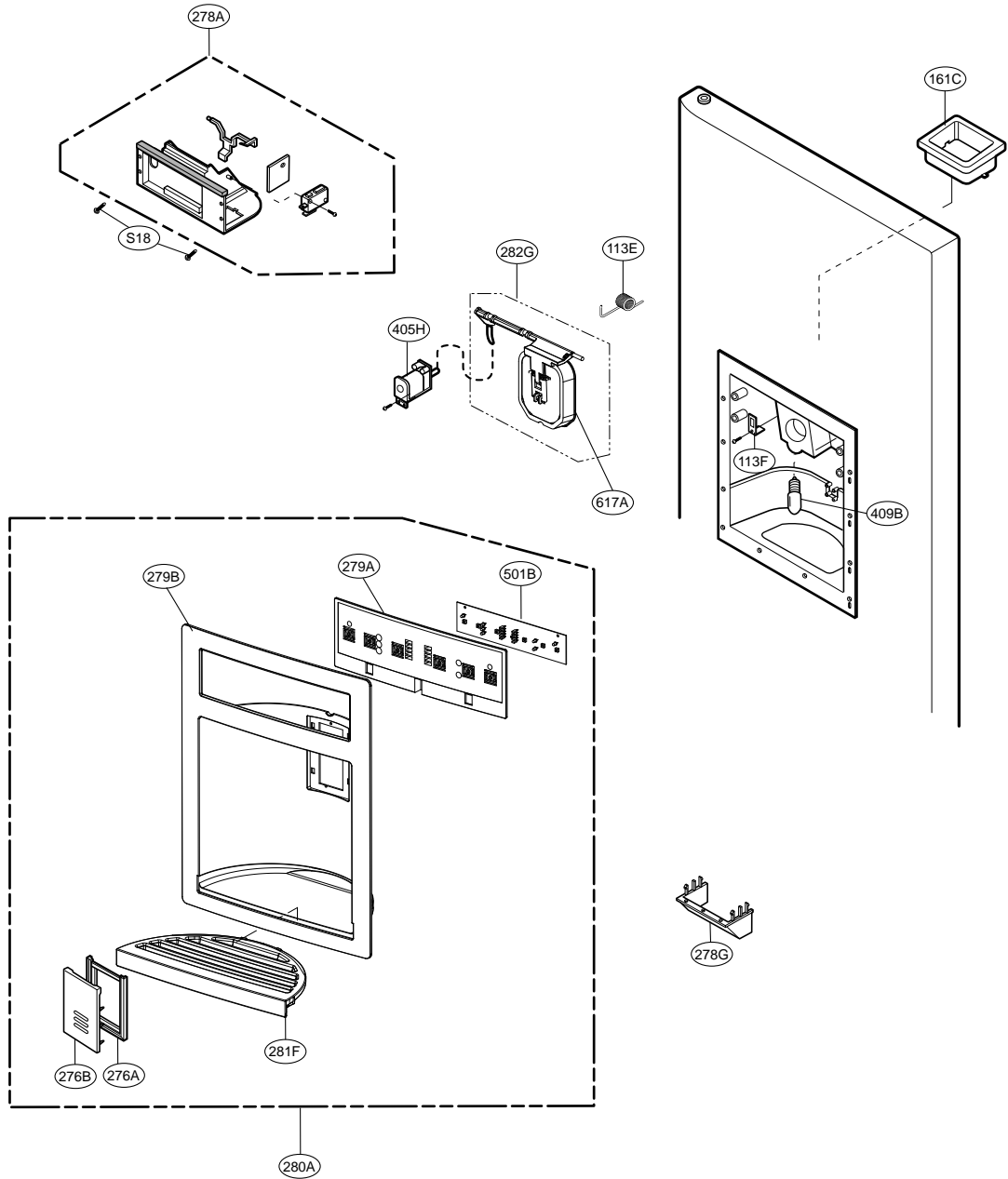

Loc No.	Part No.	Description	Loc No.	Part No.	Description
103A	3650JA3032Q	Handle,Rear	307A	TCA32241801	Compressor,Set Assembly
103B	3650JA3032R	Handle,Rear	309B	EBG44336202	Thermistor Assembly,PTC
103C	3550JJ0073A	Cover,Lower	310A	4810JJ3033B	Bracket,Cover
105A	5251JA3004A	Tube Assembly,Drain	312A	5040JA3073A	Damper,Compressor
105F	5070JJ3004C	Skirt,Lower	314A	4J03277A	Stopper,Compressor
106A	4779JA3001E	Leg Assembly,Adjust	315A	3103JJ1004A	BASE ASSEMBLY,COMPRESSOR
110B	4974JA3028A	Guide,Ice	316A	5072JA3003F	Damper,Noise
113E	4970JA3011C	Spring,Lever	316B	5072JA3003M	Damper,Noise
113F	4930JA3043A	Holder,Lever	317A	5851JJ2002F	Drier Assembly
120A	4995JJ1039C	Case Assembly,Control Refrigerator	318A	4930JA3034A	Holder,Drier
120B	5209JJ1013B	Duct Assembly,Insulation	319A	3390JJ1109A	Tray,Drip
125A	3390JA1150A	Tray,Ice	319B	3391JA2036A	Tray Assembly,Drain
128A	4975JA1021A	Guide Assembly,Rail	319C	4974JJ1053A	Guide,Fan
128B	4975JA1021B	Guide Assembly,Rail	319E	3550JA2147A	Cover,Motor
128E	4975JA1018B	Guide Assembly,Rail	323B	5403JA1003A	Condenser Assembly,Wire
128F	4975JA1018A	Guide Assembly,Rail	328A	4J03020A	Damper,Pipe
128G	MEA40002601	Guide,Rail	329A	5901JA1022A	Fan Assembly
128H	MEA40002602	Guide,Rail	329C	5901JJ1019A	FAN ASSEMBLY
128J	4975JA1022A	Guide Assembly,Rail	330B	4999JA2025B	Shroud Assembly,Freezer
128K	4975JA1022B	Guide Assembly,Rail	332A	3531JJ1010A	GRILLE ASSEMBLY,FAN
128L	MEA50433502	Guide,Air	332B	3531JJ1011B	Grille Assembly,Fan
131A	5075JJ1003C	Bucket Assembly,Ice	401A	6615JB2002R	Controller Assembly
131C	MCK50433402	Cover,Bucket Ice	404A	4681JB1029A	Motor,DC
136A	MJS32793301	Tray,Drawer	404B	4681JB1029B	DC Motor Assembly
140A	5027JJ1095E	Shelf Assembly,Refrigerator	405A	4810JA2149A	Bracket,Motor
140B	5027JJ1095F	Shelf Assembly,Refrigerator	405C	5040JA2004A	Damper,Motor Support
141A	AHT33603902	Shelf Assembly,Refrigerator	405D	5040JA2009B	Damper,Motor Support
149A	MHL48126402	Shelf,Freezer	405F	5040JA2009A	Damper,Motor Support
149D	5027JJ1098C	Shelf Assembly,Freezer	405G	5040JA2004B	Damper,Motor Support
149E	5026JJ1195A	SHELF,FREEZER	405H	6421JB2002D	Solenoid,Reversing,Valve
151A	3391JJ1041D	Tray Assembly,Vegetable	406A	6600JB3007A	Switch,Push Button
151B	3391JJ1042D	Tray Assembly,Vegetable	406D	4510JA3003C	Lever,Ice Maker
154A	3551JJ1067A	Cover Assembly,Tray	409A	6912JK2002E	Lamp,Incandescent
158A	MCK34620601	Cover,Lamp	409B	6912JB2002G	Lamp,Incandescent
158C	MCK35849501	Cover,Lamp	410G	0CZZJB2014G	Capacitor,Electric Appliance Film,Box
161A	3551JJ1063B	Cover Assembly,Tray	411A	EAD56779001	Power Cord Assembly
161B	4986JA3015A	Gasket,Cover Tray	412A	6877JB3019F	Harness Assembly
161C	3550JJ2074A	Cover,Tray	412B	6877JB2039G	Harness Assembly
170A	3390JJ1236A	Tray,Snack	412C	6620JB1001C	Socket,Lamp
200A	ADC30116540	Door Assembly,Freezer	412D	EAD37941001	Harness Assembly
201A	ADC30170441	Door Assembly,Semi Freezer	418A	5300JB1102D	Heater,Sheath
203A	4987JJ1010A	Gasket Assembly,Door	419A	5200JA1019A	Pipe,Joint
212G	4140JD1031A	Name Plate	419B	MGE58810301	Pipe,Joint
212J	4620JJ3007E	Stopper,Handle	501A	6871JB1410P	PCB Assembly,Main
230A	ADC30116630	Door Assembly,Refrigerator	501B	6871JB1391B	PCB Assembly,Display
231A	ADC30170533	Door Assembly,Semi Refrigerator	501F	3551JA1110A	Cover Assembly,PCB
233A	4987JJ1010B	Gasket Assembly,Door	501K	3110JA1071A	Case,PCB
241A	5005JJ1004C	Basket Assembly,Door	600A	5989JA1005F	Ice Maker Assembly,Kit
241B	5004JJ1183A	BASKET,DOOR	600B	5988JA1002H	Ice Maker,Unit
241C	5004JJ1184A	Basket,Window	602A	4810JA0005A	Bracket,Ice Maker
241D	AAP34518101	Basket Assembly,Door	604H	3551JA2053E	Cover Assembly,Deodorizer
241F	MAN39969001	Basket,Door	606A	4681JJ1001B	Motor,AC
241G	MAN32794701	Basket,Door	607A	4931JA3005B	Holder Assembly,Bracket
241H	AAP34518202	Basket Assembly,Door	610A	3550JA3095A	Cover,Sensor
243A	4621JA3002E	Stopper Assembly,Door	610E	3550JA2035D	Cover,Sensor
243B	4621JA3002H	Stopper Assembly,Door	611A	5231JA2002A	Filter Assembly,Water
244A	AED37133303	Handle Assembly,Refrigerator	611B	5231JA2004C	Filter Assembly,Head
271A	4775JA2083A	Hinge Assembly,Upper	611E	5007JA3007B	Cap Assembly,Head
271B	4510JA3004A	Lever,Hinge	612A	4974JA1063A	Guide,Rail
271C	4775JA2084A	Hinge Assembly,Upper	612B	4974JA1064A	Guide,Rail
276A	4930JA2074B	Holder,Button	612C	4980JA2071A	Supporter,Gear Motor
276B	5020JA2040F	Button,Lever	614A	6421JA3001Y	Solenoid,Reversing,Valve
278A	ADW34028001	Funnel Assembly	616D	5210JA3005A	Tube,Plastic
278G	3016JA2002C	Funnel	616E	5210JA2006B	Tube,Inject
279A	MDQ42651901	Frame,Display	616F	5210JA3004U	Tube,Plastic
279B	MCK42651801	Cover,Dispenser	616G	5210JA3005Q	Tube,Plastic
280A	ACQ55641804	Cover Assembly,Dispenser	617A	MBL37073101	Cap,Rubber
281A	3551JA1084D	Cover Assembly,Hinge	619A	MJX42111401	Valve,Water
281B	3551JA1084C	Cover Assembly,Hinge	621B	4932JA3012C	Connector,Tube
281C	3550JA1299D	Cover,Hinge	621C	4932JA3009A	Connector,Tube
281D	3550JA1299C	Cover,Hinge	621D	4932JA3009B	Connector,Tube
281F	MJS42652001	Tray,Drain	622B	5040JA2015A	Tube,Inlet
281G	4775JA2085A	Hinge Assembly,Lower	625A	3550JA2184A	Cover,Tube
281H	4775JA2113A	Hinge Assembly,Lower	627A	4930JA3054A	Holder,Pipe
282G	ABN32648401	Cap Assembly,Duct	627D	MEG42758601	Holder,Pipe
301A	ADL72916201	Evaporator Assembly	903D	6500JK1003A	Sensor,Temperature
303B	5410JA3011A	Insulation,Rear	903E	6500JK1004A	Sensor,Temperature
304A	3551JA1071A	Cover Assembly,Machinery(Rear)	S15	4J00415D	Screw,Customized
305B	4580JA3024B	Roller	S18	1TTG0303118	Screw,Tapping
305C	1PZZJA3013A	Pin,Common	S38	4000W4A003A	Screw,Customized

Loc No.	Part No.	Description	Loc No.	Part No.	Description
103A	3650JA3041W	Handle,Rear	307A	TCA32241801	Compressor,Set Assembly
103B	3650JA3041X	Handle,Rear	309B	EBG44336202	Thermistor Assembly,PTC
103C	3550JJ0073B	Cover,Lower	310A	4810JJ3033B	Bracket,Cover
105A	5251JA3004A	Tube Assembly,Drain	312A	5040JA3073A	Damper,Compressor
105F	5070JJ3004C	Skirt,Lower	314A	4J032777A	Stopper,Compressor
106A	4779JA3001E	Leg Assembly,Adjust	315A	3103JJ1004A	BASE ASSEMBLY,COMPRESSOR
110B	4974JA3028A	Guide,Ice	316A	5072JA3003F	Damper,Noise
113E	4970JA3011C	Spring,Lever	316B	5072JA3003M	Damper,Noise
113F	4930JA3043A	Holder,Lever	317A	5851JJ2002F	Drier Assembly
120A	4995JJ1039C	Case Assembly,Control Refrigerator	318A	4930JA3034A	Holder,Drier
120B	5209JJ1013B	Duct Assembly,Insulation	319A	3390JJ1109A	Tray,Drip
125A	3390JA1150A	Tray,Ice	319B	3391JA2036A	Tray Assembly,Drain
128A	4975JA1021A	Guide Assembly,Rail	319C	4974JJ1053A	Guide,Fan
128B	4975JA1021B	Guide Assembly,Rail	319E	3550JA2147A	Cover,Motor
128E	4975JA1018B	Guide Assembly,Rail	323B	5403JA1003A	Condenser Assembly,Wire
128F	4975JA1018A	Guide Assembly,Rail	328A	4J03020A	Damper,Pipe
128G	MEA40002601	Guide,Rail	329A	5901JA1022A	Fan Assembly
128H	MEA40002602	Guide,Rail	329C	5901JJ1019A	FAN ASSEMBLY
128J	4975JA1022A	Guide Assembly,Rail	330B	4999JA2025B	Shroud Assembly,Freezer
128K	4975JA1022B	Guide Assembly,Rail	332A	3531JJ1010A	GRILLE ASSEMBLY,FAN
128L	MEA50433502	Guide,Air	332B	3531JJ1011B	Grille Assembly,Fan
131A	5075JJ1003C	Bucket Assembly,Ice	401A	6615JB2002R	Controller Assembly
131C	MCK50433402	Cover,Bucket Ice	404A	4681JB1029A	Motor,DC
136A	MJS32793301	Tray,Drawer	404B	4681JB1029B	DC Motor Assembly
140A	5027JJ1095E	Shelf Assembly,Refrigerator	405A	4810JA2149A	Bracket,Motor
140B	5027JJ1095F	Shelf Assembly,Refrigerator	405C	5040JA2004A	Damper,Motor Support
141A	AHT33603902	Shelf Assembly,Refrigerator	405D	5040JA2009B	Damper,Motor Support
149A	MHL48126402	Shelf,Freezer	405F	5040JA2009A	Damper,Motor Support
149D	5027JJ1098C	Shelf Assembly,Freezer	405G	5040JA2004B	Damper,Motor Support
149E	5026JJ1195A	SHELF,FREEZER	405H	6421JB2002D	Solenoid,Reversing,Valve
151A	3391JJ1041D	Tray Assembly,Vegetable	406A	6600JB3007B	Switch,Push Button
151B	3391JJ1042D	Tray Assembly,Vegetable	406D	4510JA3003C	Lever,Ice Maker
154A	3551JJ1067A	Cover Assembly,Tray	409A	6912JK2002E	Lamp,Incandescent
158A	MCK34620601	Cover,Lamp	409B	6912JB2002G	Lamp,Incandescent
158C	MCK35849501	Cover,Lamp	410G	0CZJB2014G	Capacitor,Electric Appliance Film,Box
161A	3551JJ1063B	Cover Assembly,Tray	411A	EAD56779001	Power Cord Assembly
161B	4986JA3015A	Gasket,Cover Tray	412A	6877JB3019F	Harness Assembly
161C	3550JJ2074A	Cover,Tray	412B	6877JB2039G	Harness Assembly
170A	3390JJ1236A	Tray,Snack	412C	6620JB1001C	Socket,Lamp
200A	ADC30116539	Door Assembly,Freezer	412D	EAD37941001	Harness Assembly
201A	ADC30170440	Door Assembly,Semi Freezer	418A	5300JB1102D	Heater,Sheath
203A	4987JJ1010E	Gasket Assembly,Door	419A	5200JA1019A	Pipe,Joint
212G	4140JD1031A	Name Plate	419B	MGE58810301	Pipe,Joint
212J	4620JJ3007E	Stopper,Handle	501A	6871JB1410P	PCB Assembly,Main
230A	ADC30116629	Door Assembly,Refrigerator	501B	6871JB1391B	PCB Assembly,Display
231A	ADC30170532	Door Assembly,Semi Refrigerator	501F	3551JA1110B	Cover Assembly,PCB
233A	4987JJ1010F	Gasket Assembly,Door	501K	3110JA1071A	Case,PCB
241A	5005JJ1004C	Basket Assembly,Door	600A	5989JA1005F	Ice Maker Assembly,Kit
241B	5004JJ1183A	BASKET,DOOR	600B	5988JA1002H	Ice Maker,Unit
241C	5004JJ1184A	Basket,Window	602A	4810JA0005A	Bracket,Ice Maker
241D	AAP34518101	Basket Assembly,Door	604H	3551JA2053E	Cover Assembly,Deodorizer
241F	MAN39969001	Basket,Door	606A	4681JJ1001B	Motor,AC
241G	MAN32794701	Basket,Door	607A	4931JA3005B	Holder Assembly,Bracket
241H	AAP34518202	Basket Assembly,Door	610A	3550JA3095A	Cover,Sensor
243A	4621JA3002E	Stopper Assembly,Door	610E	3550JA2035D	Cover,Sensor
243B	4621JA3002H	Stopper Assembly,Door	611A	5231JA2002A	Filter Assembly,Water
244A	AED37133301	Handle Assembly,Refrigerator	611B	5231JA2004C	Filter Assembly,Head
271A	4775JA2083A	Hinge Assembly,Upper	611E	5007JA3007B	Cap Assembly,Head
271B	4510JA3004A	Lever,Hinge	612A	4974JA1063A	Guide,Rail
271C	4775JA2084A	Hinge Assembly,Upper	612B	4974JA1064A	Guide,Rail
276A	4930JA2074B	Holder,Button	612C	4980JA2071A	Supporter,Gear Motor
276B	5020JA2040E	Button,Lever	614A	6421JA3001Y	Solenoid,Reversing,Valve
278A	ADW34028003	Funnel Assembly	616D	5210JA3005A	Tube,Plastic
278G	3016JA2002K	Funnel	616E	5210JA2006B	Tube,Inject
279A	MDQ42651901	Frame,Display	616F	5210JA3004U	Tube,Plastic
279B	MCK42651803	Cover,Dispenser	616G	5210JA3005Q	Tube,Plastic
280A	ACQ55641806	Cover Assembly,Dispenser	617A	MBL37073101	Cap,Rubber
281A	3551JA1084F	Cover Assembly,Hinge	619A	MJX42111401	Valve,Water
281B	3551JA1084E	Cover Assembly,Hinge	621B	4932JA3012C	Connector,Tube
281C	3550JA1299F	Cover,Hinge	621C	4932JA3009A	Connector,Tube
281D	3550JA1299E	Cover,Hinge	621D	4932JA3009B	Connector,Tube
281F	MJS42652003	Tray,Drain	622B	5040JA2015A	Tube,Inlet
281G	4775JA2085A	Hinge Assembly,Lower	625A	3550JA2184A	Cover,Tube
281H	4775JA2113A	Hinge Assembly,Lower	627A	4930JA3054A	Holder,Pipe
282G	ABN32648401	Cap Assembly,Duct	627D	MEG42758601	Holder,Pipe
301A	ADL72916201	Evaporator Assembly	903D	6500JK1003A	Sensor,Temperature
303B	5410JA3011A	Insulation,Rear	903E	6500JK1004A	Sensor,Temperature
304A	3551JA1071A	Cover Assembly,Machinery(Rear)	S15	4J00415D	Screw,Customized
305B	4580JA3024B	Roller	S18	1TTG0303118	Screw,Tapping
305C	1PZZJA3013A	Pin,Common	S38	4000W4A003A	Screw,Customized

Loc No.	Part No.	Description	Loc No.	Part No.	Description
103A	3650JA3032W	Handle,Rear	307A	TCA32241801	Compressor,Set Assembly
103B	3650JA3032X	Handle,Rear	309B	EBG44336202	Thermistor Assembly,PTC
103C	3550JJ0073C	Cover,Lower	310A	4810JJ3033B	Bracket,Cover
105A	5251JA3004A	Tube Assembly,Drain	312A	5040JA3073A	Damper,Compressor
105F	5070JJ3004C	Skirt,Lower	314A	4J03277A	Stopper,Compressor
106A	4779JA3001E	Leg Assembly,Adjust	315A	3103JJ1004A	BASE ASSEMBLY,COMPRESSOR
110B	4974JA3028A	Guide,Ice	316A	5072JA3003F	Damper,Noise
113E	4970JA3011C	Spring,Lever	316B	5072JA3003M	Damper,Noise
113F	4930JA3043A	Holder,Lever	317A	5851JJ2002F	Drier Assembly
120A	4995JJ1039C	Case Assembly,Control Refrigerator	318A	4930JA3034A	Holder,Drier
120B	5209JJ1013B	Duct Assembly,Insulation	319A	3390JJ1109A	Tray,Drip
125A	3390JA1150A	Tray,Ice	319B	3391JA2036A	Tray Assembly,Drain
128A	4975JA1021A	Guide Assembly,Rail	319C	4974JJ1053A	Guide,Fan
128B	4975JA1021B	Guide Assembly,Rail	319E	3550JA2147A	Cover,Motor
128E	4975JA1018B	Guide Assembly,Rail	323B	5403JA1003A	Condenser Assembly,Wire
128F	4975JA1018A	Guide Assembly,Rail	328A	4J03020A	Damper,Pipe
128G	MEA40002601	Guide,Rail	329A	5901JA1022A	Fan Assembly
128H	MEA40002602	Guide,Rail	329C	5901JJ1019A	FAN ASSEMBLY
128J	4975JA1022A	Guide Assembly,Rail	330B	4999JA2025B	Shroud Assembly,Freezer
128K	4975JA1022B	Guide Assembly,Rail	332A	3531JJ1010A	GRILLE ASSEMBLY,FAN
128L	MEA50433502	Guide,Air	332B	3531JJ1011B	Grille Assembly,Fan
131A	5075JJ1003C	Bucket Assembly,Ice	401A	6615JB2002R	Controller Assembly
131C	MCK50433402	Cover,Bucket Ice	404A	4681JB1029A	Motor,DC
136A	MJS32793301	Tray,Drawer	404B	4681JB1029B	Motor Assembly,DC,Cooling
140A	5027JJ1095E	Shelf Assembly,Refrigerator	405A	4810JA2149A	Bracket,Motor
140B	5027JJ1095F	Shelf Assembly,Refrigerator	405C	5040JA2004A	Damper,Motor Support
141A	AHT33603902	Shelf Assembly,Refrigerator	405D	5040JA2009B	Damper,Motor Support
149A	MHL48126402	Shelf,Freezer	405F	5040JA2009A	Damper,Motor Support
149D	5027JJ1098C	Shelf Assembly,Freezer	405G	5040JA2004B	Damper,Motor Support
149E	5026JJ1195A	SHELF,FREEZER	405H	6421JB2002D	Solenoid,Reversing,Valve
151A	3391JJ1041D	Tray Assembly,Vegetable	406A	6600JB3007A	Switch,Push Button
151B	3391JJ1042D	Tray Assembly,Vegetable	406D	4510JA3003C	Lever,Ice Maker
154A	3551JJ1067A	Cover Assembly,Tray	409A	6912JK2002E	Lamp,Incandescent
158A	MCK34620601	Cover,Lamp	409B	6912JB2002G	Lamp,Incandescent
158C	MCK35849501	Cover,Lamp	410G	0CZZJB2014G	Capacitor,Electric Appliance Film,Box
161A	3551JJ1063B	Cover Assembly,Tray	411A	EAD56779001	Power Cord Assembly
161B	4986JA3015A	Gasket,Cover Tray	412A	6877JB3019F	Harness Assembly
161C	3550JJ2074A	Cover,Tray	412B	6877JB2039G	Harness Assembly
170A	3391JJ1040D	Tray Assembly,Snack	412C	6620JB1001C	Socket,Lamp
200A	ADC30116543	Door Assembly,Freezer	412D	EAD37941001	Harness Assembly
201A	ADC30170444	Door Assembly,Semi Freezer	418A	5300JB1102D	Heater,Sheath
203A	4987JJ1010G	Gasket Assembly,Door	419A	5200JA1019A	Pipe,Joint
212G	4140JD1031A	Name Plate	419B	MGE58810301	Pipe,Joint
212J	4620JJ3007E	Stopper,Handle	501A	6871JB1410P	PCB Assembly,Main
230A	ADC30116633	Door Assembly,Refrigerator	501B	6871JB1391B	PCB Assembly,Display
231A	ADC30170536	Door Assembly,Semi Refrigerator	501F	3551JA1110F	Cover Assembly,PCB
233A	4987JJ1010H	Gasket Assembly,Door	501K	3110JA1071A	Case,PCB
241A	5005JJ1004C	Basket Assembly,Door	600A	5989JA1005F	Ice Maker Assembly,Kit
241B	5004JJ1183A	BASKET,DOOR	600B	5988JA1002H	Ice Maker,Unit
241C	5004JJ1184A	Basket,Window	602A	4810JA0005A	Bracket,Ice Maker
241D	AAP34518101	Basket Assembly,Door	604H	3551JA2053E	Cover Assembly,Deodorizer
241F	MAN39969001	Basket,Door	606A	4681JJ1001B	Motor,AC
241G	MAN32794701	Basket,Door	607A	4931JA3005B	Holder Assembly,Bracket
241H	AAP34518202	Basket Assembly,Door	610A	3550JA3095A	Cover,Sensor
243A	4621JA3002E	Stopper Assembly,Door	610E	3550JA2035D	Cover,Sensor
243B	4621JA3002H	Stopper Assembly,Door	611A	5231JA2002B	Filter Assembly,Head
244A	AED37133304	Handle Assembly,Refrigerator	611B	5231JA2004C	Filter Assembly,Head
271A	4775JA2083A	Hinge Assembly,Upper	611E	5007JA3007B	Cap Assembly,Head
271B	4510JA3004A	Lever,Hinge	612A	4974JA1063A	Guide,Rail
271C	4775JA2084A	Hinge Assembly,Upper	612B	4974JA1064A	Guide,Rail
276A	4930JA2074B	Holder,Button	612C	4980JA2071A	Supporter,Gear Motor
276B	5020JA2040D	Button,Lever	614A	6421JA3001Y	Solenoid,Reversing,Valve
278A	ADW34028001	Funnel Assembly	616D	5210JA3005A	Tube,Plastic
278G	3016JA2002N	Funnel	616E	5210JA2006B	Tube,Inject
279A	MDQ42651901	Frame,Display	616F	5210JA3004U	Tube,Plastic
279B	MCK42651804	Cover,Dispenser	616G	5210JA3005Q	Tube,Plastic
280A	ACQ55641811	Cover Assembly,Dispenser	617A	MBL61930301	Cap,Rubber
281A	ACQ74620602	Cover Assembly,Hinge	619A	MJX42111401	Valve,Water
281B	ACQ74620601	Cover Assembly,Hinge	621B	MCD38280801	Connector,Tube
281C	3550JA1299V	Cover,Hinge	621C	4932JA3009A	Connector,Tube
281D	3550JA1299U	Cover,Hinge	621D	4932JA3009B	Connector,Tube
281F	MJS42652004	Tray,Drain	622B	5040JA2015A	Tube,Inlet
281G	4775JA2085A	Hinge Assembly,Lower	625A	3550JA2184A	Cover,Tube
281H	4775JA2113A	Hinge Assembly,Lower	627A	4930JA3054A	Holder,Pipe
282G	ABN32648401	Cap Assembly,Duct	627D	MEG42758601	Holder,Pipe
301A	ADL72916201	Evaporator Assembly	903D	6500JK1003A	Sensor,Temperature
303B	5410JA3011A	Insulation,Rear	903E	6500JK1004A	Sensor,Temperature
304A	3551JA1071A	Cover Assembly,Machinery(Rear)	S15	4J00415D	Screw,Customized
305B	4580JA3024B	Roller	S18	1TTG0303118	Screw,Tapping
305C	1PZZJA3013A	Pin,Common	S38	4000W4A003A	Screw,Customized

Loc No.	Part No.	Description			
103A	3650JA3041W	Handle,Rear	307A	TCA32241801	Compressor,Set Assembly
103B	3650JA3041X	Handle,Rear	309B	EBG44336202	Thermistor Assembly,PTC
103C	3550JJ0073B	Cover,Lower	310A	4810JJ3033B	Bracket,Cover
105A	5251JA3004A	Tube Assembly,Drain	312A	5040JA3073A	Damper,Compressor
105F	5070JJ3004C	Skirt,Lower	314A	4J03277A	Stopper,Compressor
106A	4779JA3001E	Leg Assembly,Adjust	315A	3103JJ1004A	BASE ASSEMBLY,COMPRESSOR
110B	4974JA3028A	Guide,Ice	316A	5072JA3003F	Damper,Noise
113E	4970JA3011C	Spring,Lever	316B	5072JA3003M	Damper,Noise
113F	4930JA3043A	Holder,Lever	317A	5851JJ2002F	Drier Assembly
120A	4995JJ1039C	Case Assembly,Control Refrigerator	318A	4930JA3034A	Holder,Drier
120B	5209JJ1013B	Duct Assembly,Insulation	319A	3390JJ1109A	Tray,Drip
125A	3390JA1150A	Tray,Ice	319B	3391JA2036A	Tray Assembly,Drain
128A	4975JA1021A	Guide Assembly,Rail	319C	4974JJ1053A	Guide,Fan
128B	4975JA1021B	Guide Assembly,Rail	319E	3550JA2147A	Cover,Motor
128E	4975JA1018B	Guide Assembly,Rail	323B	5403JA1003A	Condenser Assembly,Wire
128F	4975JA1018A	Guide Assembly,Rail	328A	4J03020A	Damper,Pipe
128G	MEA40002601	Guide,Rail	329A	5901JA1022A	Fan Assembly
128H	MEA40002602	Guide,Rail	329C	5901JJ1019A	FAN ASSEMBLY
128J	4975JA1022A	Guide Assembly,Rail	330B	4999JA2025B	Shroud Assembly,Freezer
128K	4975JA1022B	Guide Assembly,Rail	332A	3531JJ1010A	GRILLE ASSEMBLY,FAN
128L	MEA50433502	Guide,Air	332B	3531JJ1011B	Grille Assembly,Fan
131A	5075JJ1003C	Bucket Assembly,Ice	401A	6615JB2002R	Controller Assembly
131C	MCK50433402	Cover,Bucket Ice	404A	4681JB1029A	Motor,DC
136A	MJS32793301	Tray,Drawer	404B	4681JB1029B	DC Motor Assembly
140A	5027JJ1095E	Shelf Assembly,Refrigerator	405A	4810JA2149A	Bracket,Motor
140B	5027JJ1095F	Shelf Assembly,Refrigerator	405C	5040JA2004A	Damper,Motor Support
141A	AHT33603902	Shelf Assembly,Refrigerator	405D	5040JA2009B	Damper,Motor Support
149A	MHL48126402	Shelf,Freezer	405F	5040JA2009A	Damper,Motor Support
149D	5027JJ1098C	Shelf Assembly,Freezer	405G	5040JA2004B	Damper,Motor Support
149E	5026JJ1195A	SHELF,FREEZER	405H	6421JB2002D	Solenoid,Reversing,Valve
151A	3391JJ1041D	Tray Assembly,Vegetable	406A	6600JB3007B	Switch,Push Button
151B	3391JJ1042D	Tray Assembly,Vegetable	406D	4510JA3003C	Lever,Ice Maker
154A	3551JJ1067A	Cover Assembly,Tray	409A	6912JK2002E	Lamp,Incandescent
158A	MCK34620601	Cover,Lamp	409B	6912JB2002G	Lamp,Incandescent
158C	MCK35849501	Cover,Lamp	410G	0CZZJB2014G	Capacitor,Electric Appliance Film,Box
161A	3551JJ1063B	Cover Assembly,Tray	411A	EAD56779001	Power Cord Assembly
161B	4986JA3015A	Gasket,Cover Tray	412A	6877JB3019F	Harness Assembly
161C	3550JJ2074A	Cover,Tray	412B	6877JB2039G	Harness Assembly
170A	3390JJ1236A	Tray,Snack	412C	6620JB1001C	Socket,Lamp
200A	ADC30116542	Door Assembly,Freezer	412D	EAD37941001	Harness Assembly
201A	ADC30170443	Door Assembly,Semi Freezer	418A	5300JB1102D	Heater,Sheath
203A	4987JJ1010E	Gasket Assembly,Door	419A	5200JA1019A	Pipe,Joint
212G	4140JD1031A	Name Plate	419B	MGE58810301	Pipe,Joint
212J	4620JJ3007E	Stopper,Handle	501A	6871JB1410P	PCB Assembly,Main
230A	ADC30116632	Door Assembly,Refrigerator	501B	6871JB1391B	PCB Assembly,Display
231A	ADC30170535	Door Assembly,Semi Refrigerator	501F	3551JA1110B	Cover Assembly,PCB
233A	4987JJ1010F	Gasket Assembly,Door	501K	3110JA1071A	Case,PCB
241A	5005JJ1004C	Basket Assembly,Door	600A	5989JA1005F	Ice Maker Assembly,Kit
241B	5004JJ1183A	BASKET,DOOR	600B	5988JA1002H	Ice Maker,Unit
241C	5004JJ1184A	Basket,Window	602A	4810JA0005A	Bracket,Ice Maker
241D	AAP34518101	Basket Assembly,Door	604H	3551JA2053E	Cover Assembly,Deodorizer
241F	MAN39969001	Basket,Door	606A	4681JJ1001B	Motor,AC
241G	MAN32794701	Basket,Door	607A	4931JA3005B	Holder Assembly,Bracket
241H	AAP34518202	Basket Assembly,Door	610A	3550JA3095A	Cover,Sensor
243A	4621JA3002E	Stopper Assembly,Door	610E	3550JA2035D	Cover,Sensor
243B	4621JA3002H	Stopper Assembly,Door	611A	5231JA2002A	Filter Assembly,Water
244A	AED37133301	Handle Assembly,Refrigerator	611B	5231JA2004C	Filter Assembly,Head
271A	4775JA2083A	Hinge Assembly,Upper	611E	5007JA3007B	Cap Assembly,Head
271B	4510JA3004A	Lever,Hinge	612A	4974JA1063A	Guide,Rail
271C	4775JA2084A	Hinge Assembly,Upper	612B	4974JA1064A	Guide,Rail
276A	4930JA2074B	Holder,Button	612C	4980JA2071A	Supporter,Gear Motor
276B	5020JA2040E	Button,Lever	614A	6421JA3001Y	Solenoid,Reversing,Valve
278A	ADW34028003	Funnel Assembly	616D	5210JA3005A	Tube,Plastic
278G	3016JA2002K	Funnel	616E	5210JA2006B	Tube,Inject
279A	MDQ42651901	Frame,Display	616F	5210JA3004U	Tube,Plastic
279B	MCK42651803	Cover,Dispenser	616G	5210JA3005Q	Tube,Plastic
280A	ACQ55641806	Cover Assembly,Dispenser	617A	MBL37073101	Cap,Rubber
281A	3551JA1084F	Cover Assembly,Hinge	619A	MJX42111401	Valve,Water
281B	3551JA1084E	Cover Assembly,Hinge	621B	4932JA3012C	Connector,Tube
281C	3550JA1299F	Cover,Hinge	621C	4932JA3009A	Connector,Tube
281D	3550JA1299E	Cover,Hinge	621D	4932JA3009B	Connector,Tube
281F	MJS42652003	Tray,Drain	622B	5040JA2015A	Tube,Inlet
281G	4775JA2085A	Hinge Assembly,Lower	625A	3550JA2184A	Cover,Tube
281H	4775JA2113A	Hinge Assembly,Lower	627A	4930JA3054A	Holder,Pipe
282G	ABN32648401	Cap Assembly,Duct	627D	MEG42758601	Holder,Pipe
301A	ADL72916201	Evaporator Assembly	903D	6500JK1003A	Sensor, Temperature
303B	5410JA3011A	Insulation,Rear	903E	6500JK1004A	Sensor, Temperature
304A	3551JA1071A	Cover Assembly,Machinery(Rear)	S15	4J00415D	Screw,Customized
305B	4580JA3024B	Roller	S18	1TTG0303118	Screw,Tapping
305C	1PZZJA3013A	Pin,Common	S38	4000W4A003A	Screw,Customized

Loc No.	Part No.	Description	Loc No.	Part No.	Description
103A	3650JA3041Y	Handle,Rear	307A	TCA32241801	Compressor,Set Assembly
103B	3650JA3041Z	Handle,Rear	309B	EBG44336202	Thermistor Assembly,PTC
103C	3550JJ0073D	Cover,Lower	310A	4810JJ3033B	Bracket,Cover
105A	5251JA3004A	Tube Assembly,Drain	312A	5040JA3073A	Damper,Compressor
105F	5070JJ3004C	Skirt,Lower	314A	4J03277A	Stopper,Compressor
106A	4779JA3001E	Leg Assembly,Adjust	315A	3103JJ1004A	BASE ASSEMBLY,COMPRESSOR
110B	4974JA3028A	Guide,Ice	316A	5072JA3003F	Damper,Noise
113E	4970JA3011C	Spring,Lever	316B	5072JA3003M	Damper,Noise
113F	4930JA3043A	Holder,Lever	317A	5851JJ2002F	Drier Assembly
120A	4995JJ1039C	Case Assembly,Control Refrigerator	318A	4930JA3034A	Holder,Drier
120B	5209JJ1013B	Duct Assembly,Insulation	319A	3390JJ1109A	Tray,Drip
125A	3390JA1150A	Tray,Ice	319B	3391JA2036A	Tray Assembly,Drain
128A	4975JA1021A	Guide Assembly,Rail	319C	4974JJ1053A	Guide,Fan
128B	4975JA1021B	Guide Assembly,Rail	319E	3550JA2147A	Cover,Motor
128E	4975JA1018B	Guide Assembly,Rail	323B	5403JA1003A	Condenser Assembly,Wire
128F	4975JA1018A	Guide Assembly,Rail	328A	4J03020A	Damper,Pipe
128G	MEA40002601	Guide,Rail	329A	5901JA1022A	Fan Assembly
128H	MEA40002602	Guide,Rail	329C	5901JJ1019A	FAN ASSEMBLY
128J	4975JA1022A	Guide Assembly,Rail	330B	4999JA2025B	Shroud Assembly,Freezer
128K	4975JA1022B	Guide Assembly,Rail	332A	3531JJ1010A	GRILLE ASSEMBLY,FAN
128L	MEA50433502	Guide,Air	332B	3531JJ1011B	Grille Assembly,Fan
131A	5075JJ1003C	Bucket Assembly,Ice	401A	6615JB2002R	Controller Assembly
131C	MCK50433402	Cover,Bucket Ice	404A	4681JB1029A	Motor,DC
136A	MJS32793301	Tray,Drawer	404B	4681JB1029B	DC Motor Assembly
140A	5027JJ1095E	Shelf Assembly,Refrigerator	405A	4810JA2149A	Bracket,Motor
140B	5027JJ1095F	Shelf Assembly,Refrigerator	405C	5040JA2004A	Damper,Motor Support
141A	AHT33603902	Shelf Assembly,Refrigerator	405D	5040JA2009B	Damper,Motor Support
149A	MHL48126402	Shelf,Freezer	405F	5040JA2009A	Damper,Motor Support
149D	5027JJ1098C	Shelf Assembly,Freezer	405G	5040JA2004B	Damper,Motor Support
149E	5026JJ1195A	SHELF,FREEZER	405H	6421JB2002D	Solenoid,Reversing,Valve
151A	3391JJ1041D	Tray Assembly,Vegetable	406A	6600JB3007E	Switch,Push Button
151B	3391JJ1042D	Tray Assembly,Vegetable	406D	4510JA3003C	Lever,Ice Maker
154A	3551JJ1067A	Cover Assembly,Tray	409A	6912JK2002E	Lamp,Incandescent
158A	MCK34620601	Cover,Lamp	409B	6912JB2002G	Lamp,Incandescent
158C	MCK35849501	Cover,Lamp	410G	0CZZJB2014G	Capacitor,Electric Appliance Film,Box
161A	3551JJ1063B	Cover Assembly,Tray	411A	EAD56779001	Power Cord Assembly
161B	4986JA3015A	Gasket,Cover Tray	412A	6877JB3019F	Harness Assembly
161C	3550JJ2074A	Cover,Tray	412B	6877JB2039G	Harness Assembly
170A	3390JJ1236A	Tray,Snack	412C	6620JB1001C	Socket,Lamp
200A	ADC30116541	Door Assembly,Freezer	412D	EAD37941001	Harness Assembly
201A	ADC30170442	Door Assembly,Semi Freezer	418A	5300JB1102D	Heater,Sheath
203A	4987JJ1010C	Gasket Assembly,Door	419A	5200JA1019A	Pipe,Joint
212G	4140JD1031A	Name Plate	419B	MGE58810301	Pipe,Joint
212J	4620JJ3007E	Stopper,Handle	501A	6871JB1410P	PCB Assembly,Main
230A	ADC30116631	Door Assembly,Refrigerator	501B	6871JB1391B	PCB Assembly,Display
231A	ADC30170534	Door Assembly,Semi Refrigerator	501F	3551JA1110D	Cover Assembly,PCB
233A	4987JJ1010D	Gasket Assembly,Door	501K	3110JA1071A	Case,PCB
241A	5005JJ1004C	Basket Assembly,Door	600A	5989JA1005F	Ice Maker Assembly,Kit
241B	5004JJ1183A	BASKET,DOOR	600B	5988JA1002H	Ice Maker,Unit
241C	5004JJ1184A	Basket,Window	602A	4810JA0005A	Bracket,Ice Maker
241D	AAP34518101	Basket Assembly,Door	604H	3551JA2053E	Cover Assembly,Deodorizer
241F	MAN39969001	Basket,Door	606A	4681JJ1001B	Motor,AC
241G	MAN32794701	Basket,Door	607A	4931JA3005B	Holder Assembly,Bracket
241H	AAP34518202	Basket Assembly,Door	610A	3550JA3095A	Cover,Sensor
243A	4621JA3002E	Stopper Assembly,Door	610E	3550JA2035D	Cover,Sensor
243B	4621JA3002H	Stopper Assembly,Door	611A	5231JA2002A	Filter Assembly,Water
244A	AED37133302	Handle Assembly,Refrigerator	611B	5231JA2004C	Filter Assembly,Head
271A	4775JA2083A	Hinge Assembly,Upper	611E	5007JA3007B	Cap Assembly,Head
271B	4510JA3004A	Lever,Hinge	612A	4974JA1063A	Guide,Rail
271C	4775JA2084A	Hinge Assembly,Upper	612B	4974JA1064A	Guide,Rail
276A	4930JA2074B	Holder,Button	612C	4980JA2071A	Supporter,Gear Motor
276B	5020JA2040K	Button,Lever	614A	6421JA3001Y	Solenoid,Reversing,Valve
278A	ADW34028002	Funnel Assembly	616D	5210JA3005A	Tube,Plastic
278G	3016JA2002G	Funnel	616E	5210JA2006B	Tube,Inject
279A	MDQ42651901	Frame,Display	616F	5210JA3004U	Tube,Plastic
279B	MCK42651802	Cover,Dispenser	616G	5210JA3005Q	Tube,Plastic
280A	ACQ55641805	Cover Assembly,Dispenser	617A	MBL37073101	Cap,Rubber
281A	3551JA1084H	Cover Assembly,Hinge	619A	MJX42111401	Valve,Water
281B	3551JA1084G	Cover Assembly,Hinge	621B	4932JA3012C	Connector,Tube
281C	3550JA1299G	Cover,Hinge	621C	4932JA3009A	Connector,Tube
281D	3550JA1299H	Cover,Hinge	621D	4932JA3009B	Connector,Tube
281F	MJS42652002	Tray,Drain	622B	5040JA2015A	Tube,Inlet
281G	4775JA2085A	Hinge Assembly,Lower	625A	3550JA2184A	Cover,Tube
281H	4775JA2113A	Hinge Assembly,Lower	627A	4930JA3054A	Holder,Pipe
282G	ABN32648401	Cap Assembly,Duct	627D	MEG42758601	Holder,Pipe
301A	ADL72916201	Evaporator Assembly	903D	6500JK1003A	Sensor,Temperature
303B	5410JA3011A	Insulation,Rear	903E	6500JK1004A	Sensor,Temperature
304A	3551JA1071A	Cover Assembly,Machinery(Rear)	S15	4J00415D	Screw,Customized
305B	4580JA3024B	Roller	S18	1TTG0303118	Screw,Tapping
305C	1PZZJA3013A	Pin,Common	S38	4000W4A003A	Screw,Customized



*'You Can Count on me . . .
to Work Safely.'*