



SXS REFRIGERATOR **SERVICE MANUAL**

CAUTION

**PLEASE READ THE SAFETY PRECAUTIONS OF THIS MANUAL CAREFULLY
BEFORE REPAIRING OR OPERATING THE REFRIGERATOR**



MODELS:

LSC27910SW /01
LSC27910ST /01
LSC27910TT /01
LSC27910SB /01

ECN (Engineering Change Number)

Rev.01

Change Base Compressor (due to Back Prone Loading transportation)

Items related to this change:

- Damper, Compressor (312A)
- Stopper, Compressor (314A)
- Base Assembly, Compressor (315A)

CONTENTS

WARNINGS AND SAFETY PRECAUTIONS	3
1. SPECIFICATIONS	4
2. PARTS IDENTIFICATION	5
3. HOW TO INSTALL THE REFRIGERATOR	6
4. HOW TO DISASSEMBLE AND ASSEMBLE.....	10
5. MICOM FUNCTION	15
6. EXPLANATION FOR MICOM CIRCUIT	25
7. ICEMAKER AND DISPENSER WORKING PRINCIPLES AND REPAIR.....	42
8. CIRCUIT	48
9. TROUBLE DIAGNOSIS	49
10. EXPLODED VIEW	88

WARNINGS AND PRECAUTIONS FOR SAFETY

Please observe the following safety precautions to use the refrigerator safely and correctly and to prevent accident or injury when servicing.

1. Be careful of an electric shock. Disconnect power cord from wall outlet and wait for more than three minutes before replacing PWB parts. Shut off the power whenever replacing and repairing electric components.

2. When connecting power cord, wait for more than five minutes after power cord was disconnected from the wall outlet.

3. Check if the power plug or cord is pinched between the refrigerator and the wall. If the cord is damaged, it could cause fire or electric shock.

4. If the wall outlet is overloaded, it may cause a fire. Use a dedicated circuit for the refrigerator.

5. Be sure the outlet is grounded. This is particularly important in wet or damp areas.

6. Use standard electrical components.

7. Make sure hooks are correctly engaged. Remove dust and foreign materials from the housing and connecting parts.

8. Do not fray, damage, run over, kink, bend, pull out, or twist the power cord.

9. Please check for evidence of moisture intrusion in the electrical components. Replace the parts or mask with insulation tape if moisture intrusion was confirmed.

10. Do not touch the icemaker with hands or tools to confirm the operation of geared motor.

11. Do not suggest that customers repair their refrigerator themselves. This work requires special tools and knowledge. Non-professionals could cause fire, injury, or damage to the product.

12. Do not store flammable materials such as ether, benzene, alcohol, chemicals, gas, or medicine in the refrigerator.

13. Do not put anything on top of the refrigerator, especially something containing water, like a vase.

14. Do not put glass bottles full of water into the freezer. The contents will freeze and break the glass period.

15. When you scrap or discard the refrigerator, remove the doors and dispose of it where children are not likely to play in or around it.

1. SPECIFICATIONS

SPECIFICATIONS	MODELS				SPECIFICATIONS	MODELS			
	LSC27910SW	LSC27910ST	LSC27910TT	LSC27910SB		LSC27910SW	LSC27910ST	LSC27910TT	LSC27910SB
Color	Super white	Stainless	Titanium	Black	Case Material	Embo (normal)			
Dimensions	36 x 33 x 70 in				Door Material	PCM	Stainless	VCM	VCM
Net Weight	286.6 lbs				Handle Type	Vista			
Capacity	27 cuft				Display Graphic	A-LG			
Refrigerant	R134a (185gr)				Basket, Quantity	3 full + 1half			
Climate class	Temperate (N)				Ice Tray & Bank	AUTO ICE MAKER+ SPACE PLUS			
Rated Rating	115V~ / 60Hz				Magic Crisper	Yes			
Cooling System	Fan Cooling				Lamp	Yes (1) 40W/Blue			
Temperature Control	MICOM control				Shelf	1 (Fix) + 2 (S/Out)			
Defrosting System	Full Automatic				Tray meat	Yes			
	Heater Defrost				Egg Bank	No			
Insulation	Cyclo, Pentane				Basket, Quantity	3 Plastic			
Compressor	LD72LACH PTC Starting Type				Lamp	Yes (1) 40W/Blue			
Evaporator	Fin Tube Type				Shelf	3 EA (Wire)			
Condenser	Wire Condenser								
Lubricating Oil	Polyol Ester 310 ± 10 cc								
Drier	MOLECULAR SIEVE XH-7								
Capillary Tube	ID Ø0.83								
First Defrost	4 Hours								
Defrost Cycle	13 - 70 Hours								
Defrosting Device	Heater, Sheath								
Anti-freezing Heater	Water Tank Heater								

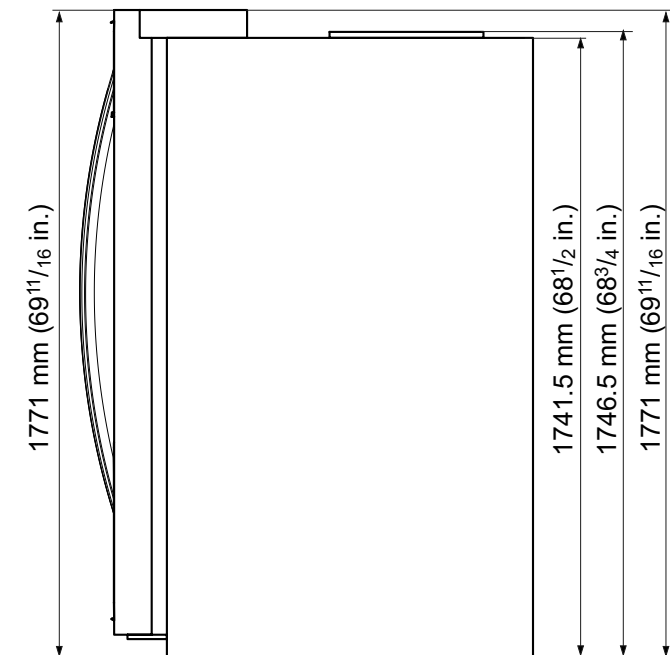

Front View

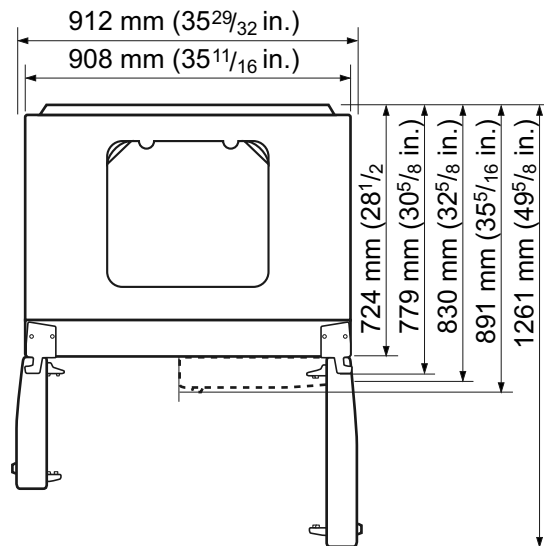

Top View

2. PARTS IDENTIFICATION

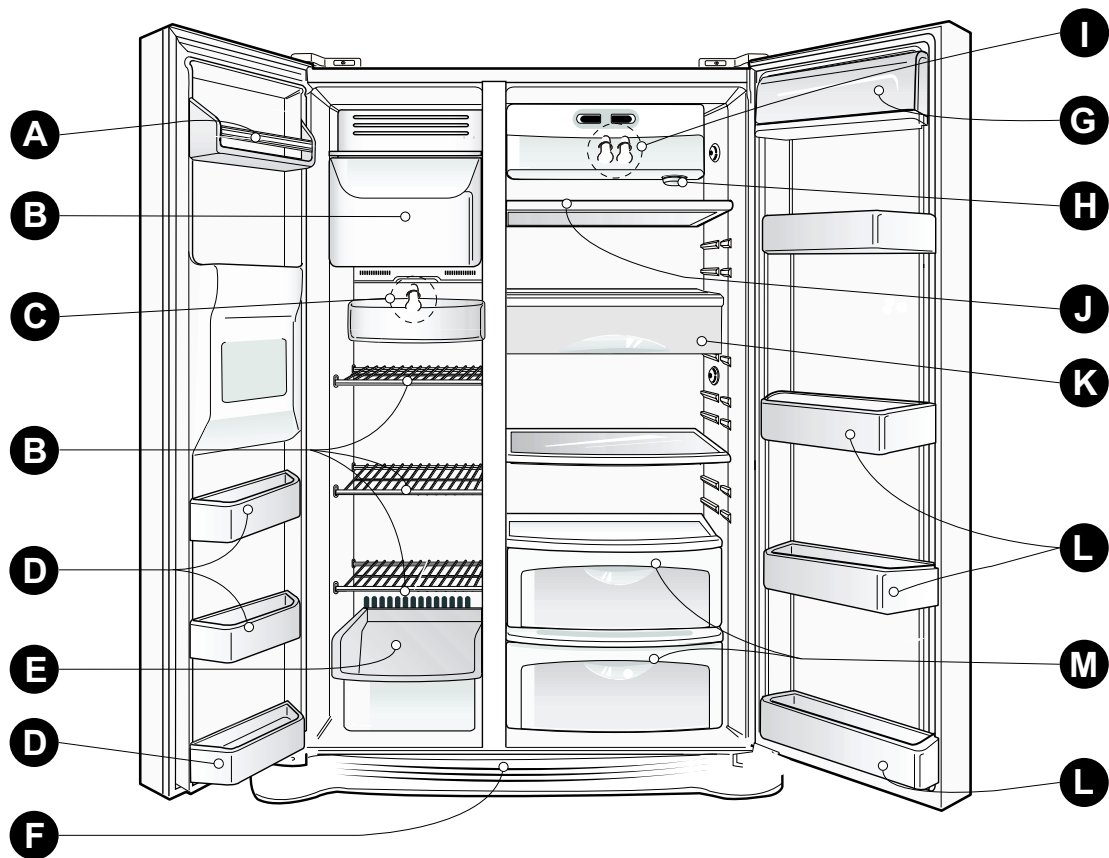

Use this page to become more familiar with the parts and features. Page references are included for your convenience.

Note: This guide covers several different models. The refrigerator you have purchased may have some or all of the items listed below. The locations of the features shown below may not match your model.

- A** Freezer Shelf
- B** Ice Bin
For storage of ice cubes made by the icemaker.
Do not store anything except ice in the ice bin.
- C** Freezer Lamp
- D** Freezer Door Rack
- E** Drawer
- F** Base Grille
- G** Dairy Corner
For storage of dairy products such as butter and cheese.
- H** Water Filter
- I** Refrigerator Lamp
- J** Refrigerator Shelf
- K** Snack Pan
For storage of meat or fresh food.
- L** Refrigerator Door Rack
- M** Vegetable Drawer

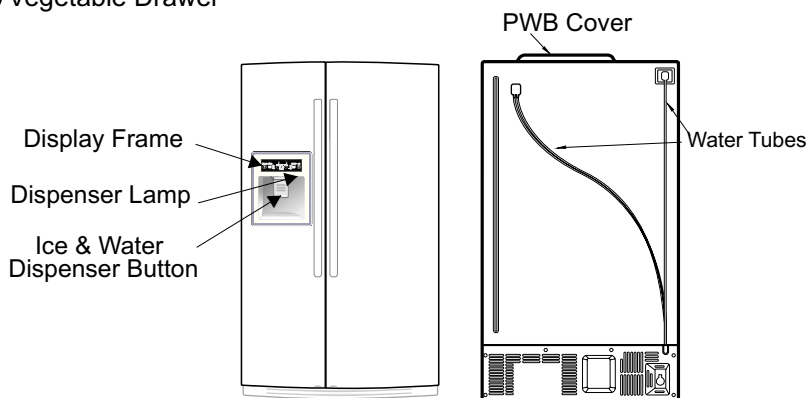

3. HOW TO INSTALL THE REFRIGERATOR

1. DOOR ALIGNMENT

Before adjust the doors, remove the Base Grille.

If the freezer compartment door is lower than the refrigerator compartment door, make them level by inserting flat blade screwdriver into the groove of the left leveling leg and rotating it clockwise.

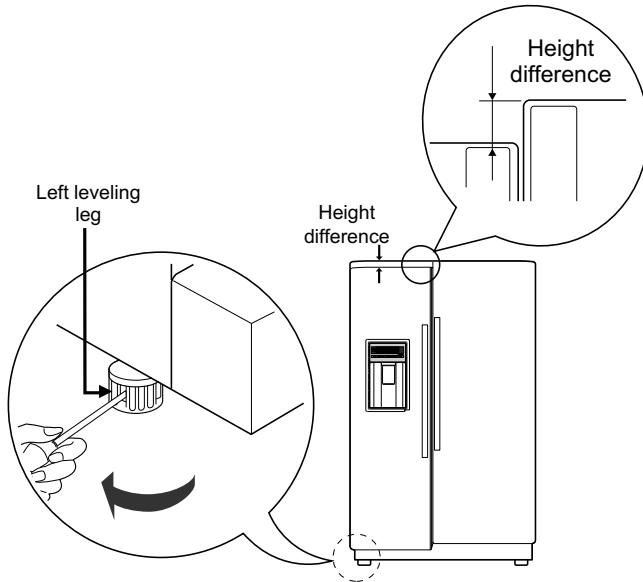

If the freezer compartment door is higher than the refrigerator compartment door, make them level by inserting flat blade screwdriver into the groove of the right leveling leg and rotating it clockwise.

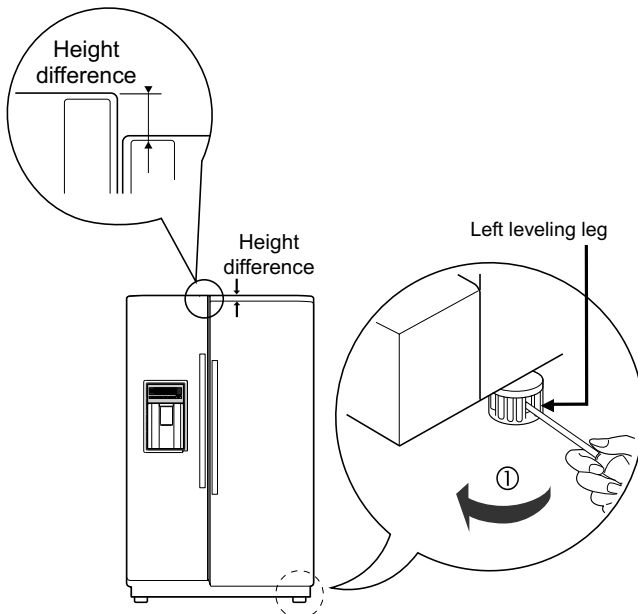

Adjust the level when the refrigerator door is lower than the freezer door during the installation of the refrigerator.

Tools you need

- Wrench 5/16 in (8 mm)
- Wrench 3/4 in (19 mm)

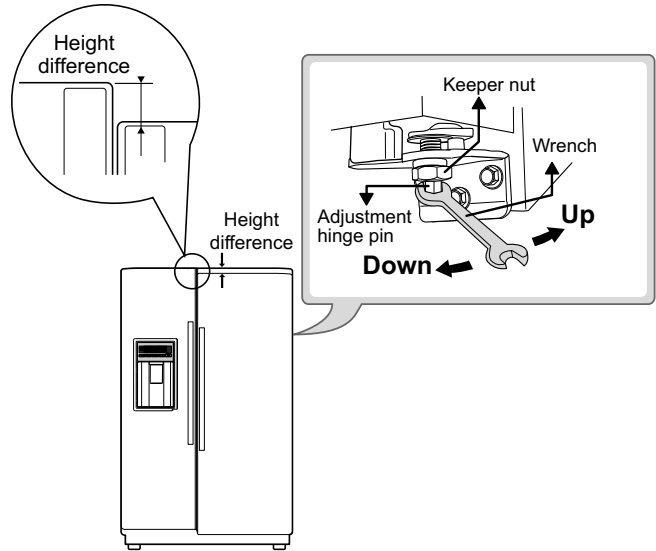

Using a 3/4" (19 mm) wrench, turn the keeper nut clockwise to loosen the keeper nut.

Using a 5/16" (8 mm) wrench, turn the adjustment hinge pin clockwise or counterclockwise to level the refrigerator and freezer door.

After setting the level door, turn the keeper nut counterclockwise to tighten.

Do not over tightening the door adjustment screw. The hinge pin can be pulled out. (Adjustable range of height is a maximum of 1/2" (1.27 cm)).

AFTER LEVELING THE DOOR HEIGHT

Make sure the front leveling legs are completely touching the floor.

2. WATER FILTER

Before removing or installing water filter:

1. Take out the top shelf and move it to the lowest level.
2. Remove the lamp cover by pressing the tab under the cover and pulling cover to the front.
3. **IMPORTANT:** Turn off household water supply.

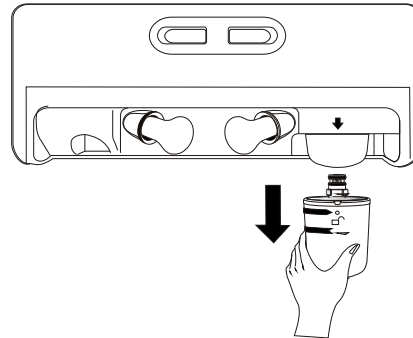
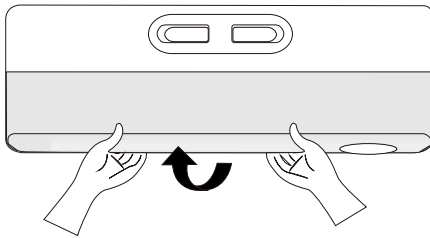
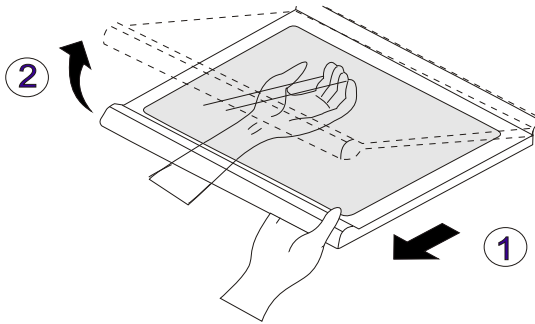

Installing the water filter

Remove red cap from the filter and insert the two tabs on the filter tip into the two slots in the refrigerator filter receptacle. You should feel the filter entering completely. Turn the filter to the right a quarter turn clockwise to lock it into place. The locked symbol will be lined up with the indicator arrow.

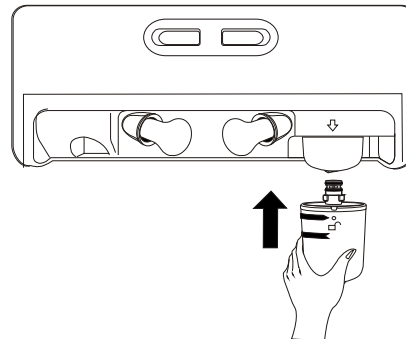

Removing the water filter:

1. For first-time installation, remove filter substitute cap (A) by turning it counterclockwise a quarter turn and pulling it down.
2. For subsequent installation, remove old filter by slowly turning it to the left a quarter turn and pulling it down.

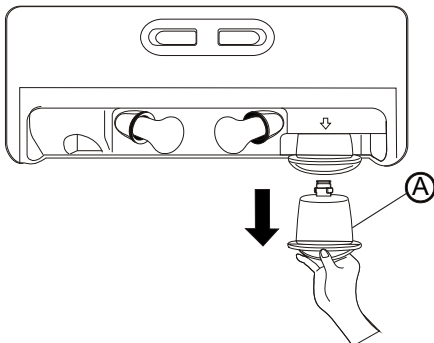

After installing water filter

- a) Replace the cover lamp and shelf to the initial position.
- b) Dispense 2.5 gallons (9.46 L) of water to purge the system (dispense for approximately 5 minutes). Open the refrigerator door and check the shelf area for leaks.
- c) After installing filter, turn on household water supply.

3. HOW TO CONTROL THE AMOUNT OF WATER SUPPLIED TO ICEMAKER

3-1. Confirm the amount of water supplied to the icemaker

1. Pull out the ice bin shelf in the upper part of the freezer compartment.

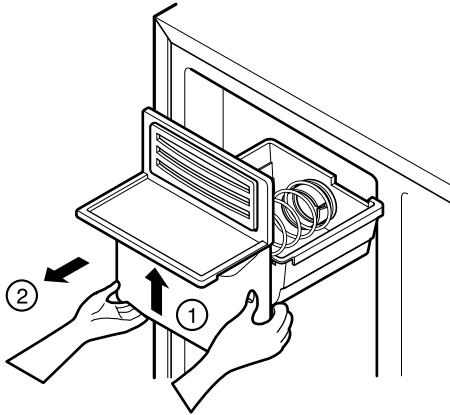

Caution: •Do not put hands or tools into the chute to confirm the operation of geared motor.
It may damage the refrigerator or hurt your hands.

2. Turn on the electricity after connecting water pipe.

- 1) Press the test switch under the icemaker for two seconds as shown below.
- 2) The bell rings (ding ~ dong), the ice tray rotates, and water comes out the icemaker water tube.
- 3) The water is supplied into the tray two or three times. The amount is small each time.
Put a container under the ice tray and press test switch.
- 4) When the ice tray rotates, the water in it will spill. Collect the spilled water and discard it.
- 5) When ice tray has finished rotation, water comes out the water tube. Check the amount that goes into the ice tray. (Refer to the drawing below. The optimum amount is 110cc. (Almost 4 oz.)).

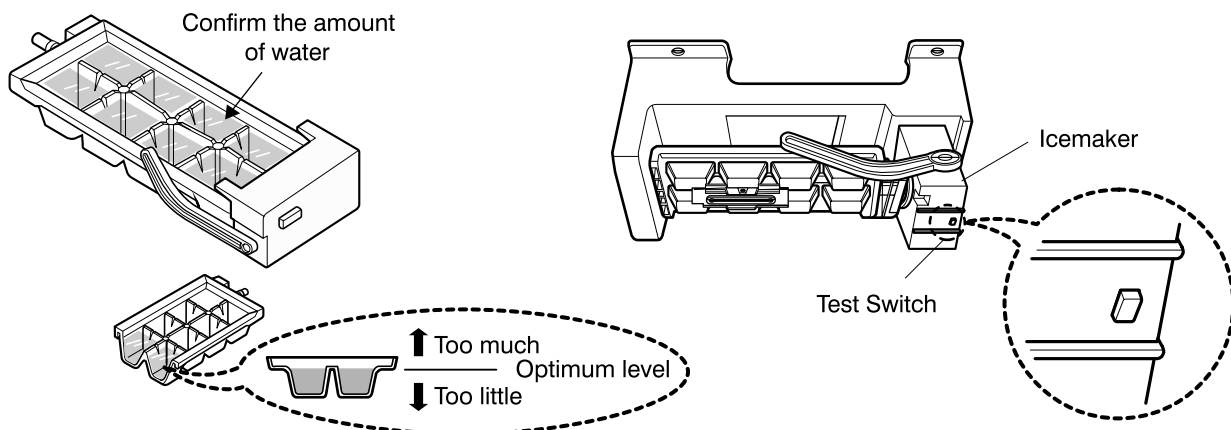

* It is acceptable if the adjusted water level is less than the optimum level.

3-2 Control the amount of water supplied to the icemaker.

Caution: • Unplug the power cord from the wall outlet and wait at least three minutes before removing the main PWB cover. 310 Volts are present in the control panel.

1. Disconnect PWB cover from the upper part of the refrigerator.
2. Adjust the amount of water supplied by using the DIP switches.

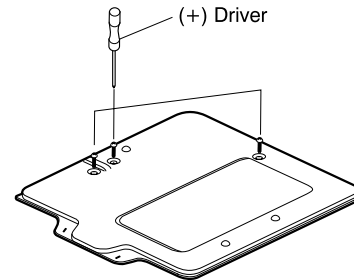

Water Supplying Time Control Option

SWITCH		WATER SUPPLY TIME	NOTE
SW2	SW1		
OFF	OFF	6.5s	FACTORY SETTING
OFF	ON	5.5s	
ON	OFF	7.5s	
ON	ON	8.5s	

- 1) The water supplying time is set at five seconds when the refrigerator is delivered.
- 2) The amount of water supplied depends on the setting time and water pressure (city water pressure).
- 3) If the ice cubes are too small, increase the water supplying time. This happens when too little water is supplied **into the ice tray**.
- 4) If the ice cubes stick together, decrease the water supplying time. This happens when too much water is supplied **into the ice tray**.

Caution: When adjusting the amount of water supplied, adjust step by step. Otherwise the water may spill over.

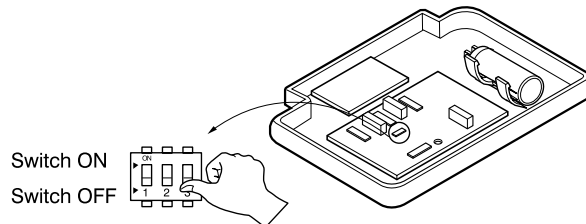

3. When the adjustment of the control switch for the amount of water supplied is complete, check the level of water in the ice.

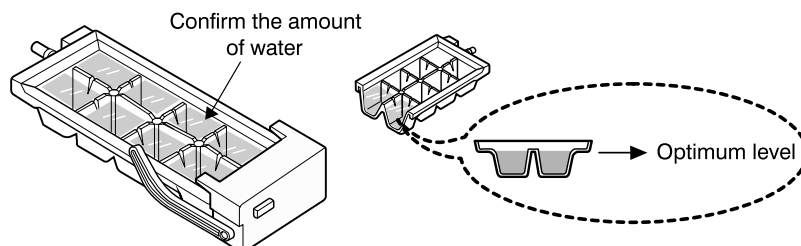

4. HOW TO DISASSEMBLY AND ASSEMBLE

1. REMOVING AND REPLACING REFRIGERATOR DOORS

Before remove the doors, remove the Base Grille.

To remove the right (refrigerator) door:

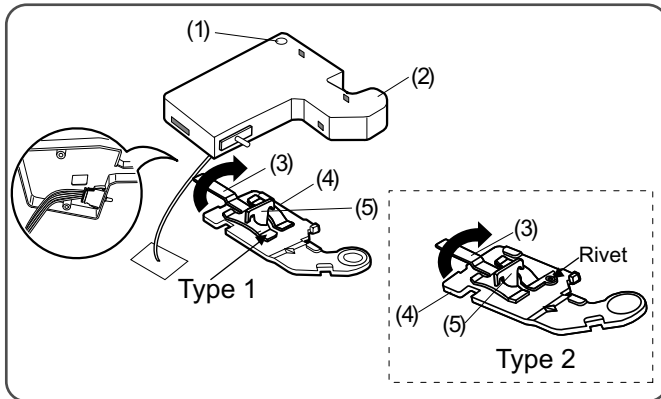

1. Open the door. Remove the top hinge cover screw (1).
2. Use a flat blade screwdriver to pry back the hooks (not shown) on the cabinet underside of the cover (2). Lift up the cover.
3. Rotate the hinge lever (3) clockwise. Lift the top hinge (4) free of the hinge lever latch (5).

NOTE: Regardless the type of hinge lever (3); type1: without rivet or type 2: with rivet the removal process is the same.

4. Lift the door from the lower hinge pin.
5. Place the door, inside facing up, on a nonscratching surface.

CAUTION: When lifting the hinge free of the latch, be careful that the door does not fall forward.

Removing the left (freezer) door with water line connection.

- Pull up the water feed tube while pressing area (Figure 1) as shown in the figure below.
- **NOTE:** If a tube end is deformed or abraded, trim the part away. Disconnecting the tube under the door causes about 0.5 liters water to flow out. Put a large container at end of tube to prevent water from draining onto the floor.

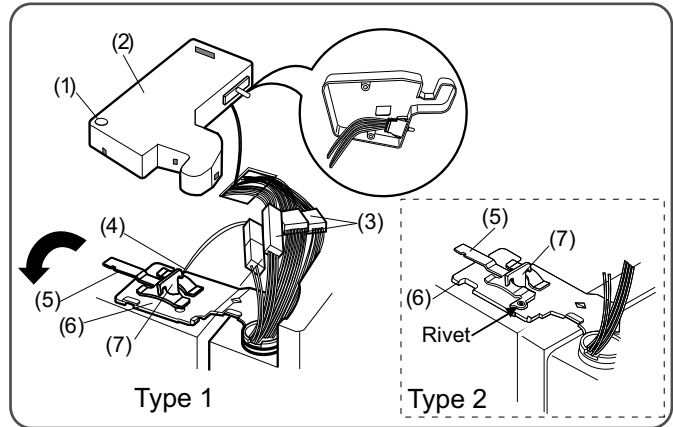
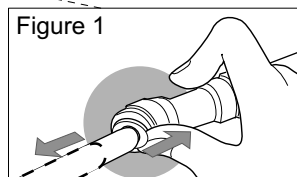

1. Open the door. Remove the top hinge cover screw (1).
2. Use a flat blade screwdriver to pry back the hooks (not shown) on the cabinet underside of the cover (2). Lift up the cover.
3. Disconnect all the wire harnesses (3).
4. Remove the grounding screw (4).
5. Rotate hinge lever (5) counterclockwise. Lift the top hinge (6) free of the hinge lever latch (7).

NOTE: Regardless the type of hinge lever (5); type1: without rivet or type 2: with rivet the removal process is the same.

CAUTION: When lifting the hinge free of the latch, be careful that the door does not fall forward.

6. Lift the door from the lower hinge pin being careful to pull the water lines through the lower hinge pin.
7. Place the door, inside facing up, on a nonscratching surface.

Reinstalling the right (Refrigerator) door

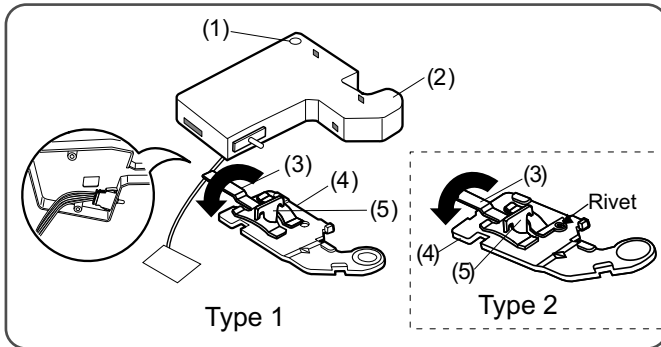

1. Place the door onto the lower hinge pin.
2. Fit top hinge (4) over hinge lever latch (5) into place. Rotate lever (3) counterclockwise to secure hinge.

NOTE: Regardless the type of hinge lever (3);
type1: without rivet or type 2: with rivet the
removal process is the same.

3. Hook tab on switch side of corner under edge of wire opening in cabinet top. Position cover (2) into place. Insert and tighten cover screw (1).

Reinstalling the left (Freezer) door

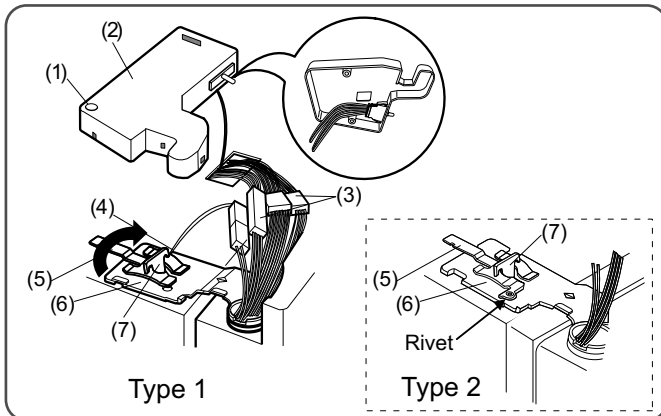

1. Feed the water tubes through the lower hinge pin and place the door onto the lower hinge pin.
2. Fit top hinge (6) over hinge lever latch (7) and into place. Rotate lever (5) clockwise to secure hinge

NOTE: Regardless the type of hinge lever (5);
type1: without rivet or type 2: with rivet the
removal process is the same.

3. Install the grounding screw (4) and connect all the wire harnesses (3).
4. Hook tab on door switch side of cover (2) under edge of wire opening in cabinet top. Position cover into place. Insert and tighten cover screw (1).
5. Reconnect the water tubes by inserting the tubes into the connectors.

2. HANDLE REMOVAL

- Loosen the set screws with a 3/32" (2.38 mm) Allen wrench and remove the handle.

NOTE: If the handle mounting fasteners need to be tightened or moved, use a 1/4" (6.35 mm) Allen wrench.

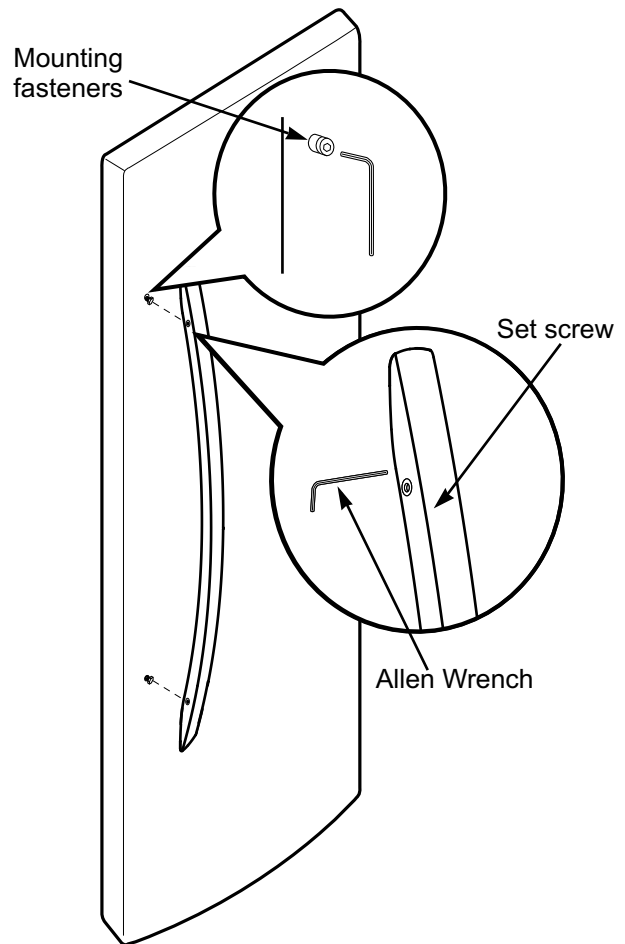

3. FAN SHROUD GRILLE

1. Loose one screw with a screwdriver blade.
2. Disassembly of an upper grille fan: Hold upper part of an upper grille fan (U) and pull forward carefully.
3. Disassembly of a lower grille fan: Hold upper part of a lower grille fan and pull forward carefully.
4. Disassembly of an upper freezer shroud: Hold lower part, pull forward and disconnect housing A and B.
5. Check foam sticking conditions around a shroud, upper freezer and lower freezer during assembling. If damaged torn, or badly stuck, assemble with a new one after sealing well.

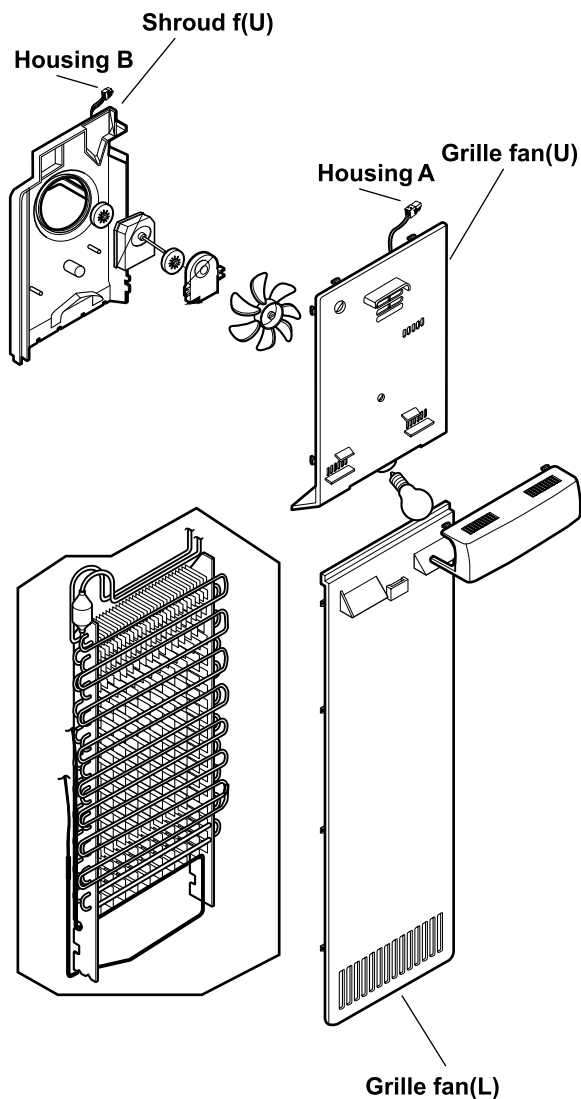

4. ICEMAKER ASSEMBLY

1. Dispenser Model

1) How to disassemble:

- (1) Remove ice bin from the freezer compartment.
- (2) Loose the screw on the upper part of icemaker bracket.
- (3) Disconnect icemaker bracket so that it can slide forward.
- (4) Disconnect icemaker housing and sensor housing.
- (5) Disconnect icemaker horizontally by pressing bracket hook part. (Don't disassemble further. The set value may be changed).

2) The assembly is the reverse order of the above disassembly.

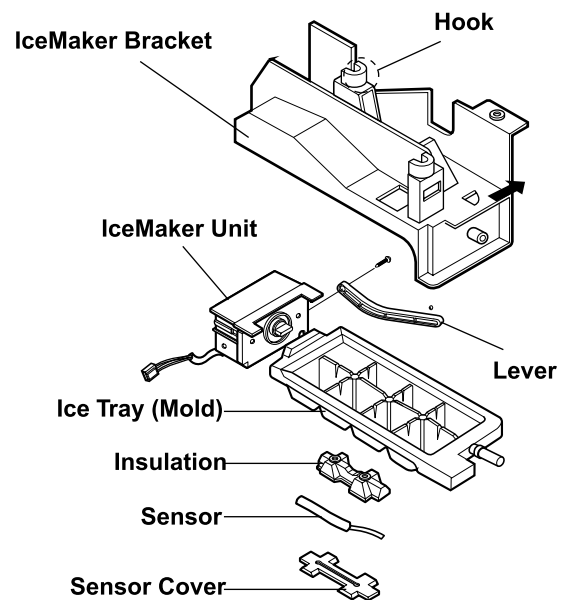

NOTE: If the ice tray (mold) is not horizontal after repair and assembly, something must be wrong. Check it and reassemble if necessary.

5. WATER VALVE DISASSEMBLY

- 1) Turn off the power of the refrigerator (pull out the plug).
Open the F/R Door and disassemble the Lower Cover.



- 2) Lay a dry towel on the floor and get ready to pour water from the water tank.
Then press the collet to separate the tube from the connector and pour out the water until emptied.
(Refer to the label attached on Front L on how to separate the tube.)

• Disassembly

1. Pull out tube while pressing collets and disassemble it.

• Assembly

1. Insert tube until you can see only one line.
2. After inserting, pull out tube to check if it is properly inserted.

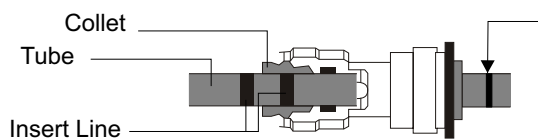

- 3) Lock the water being supplied. Then separate the Water Connection connected to the Water Valve.

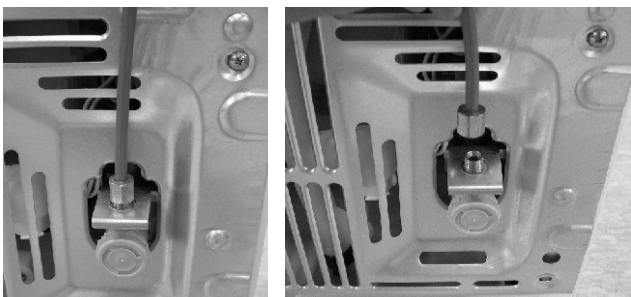

- 4). Separate the Cover Back M/C and Valve Screw.

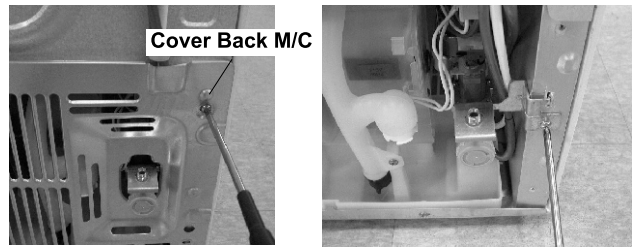

- 5) Separate the housing and pull out the valve.

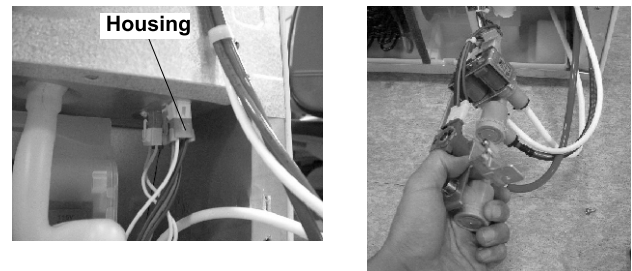

6. FAN AND FAN MOTOR DISASSEMBLY METHOD

- 1) Using a short screw driver, loosen one SCREW in DRAIN ASSEMBLY, PIPE-Z and one connected to the COVER, MOTOR.

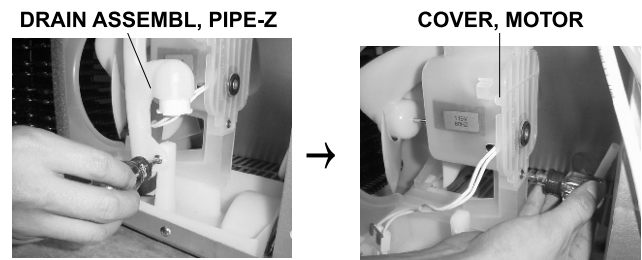

- 2) Pull and separate the FAN ASSEMBLY and MOTOR in counter clockwise based on the MOTOR SHAFT.

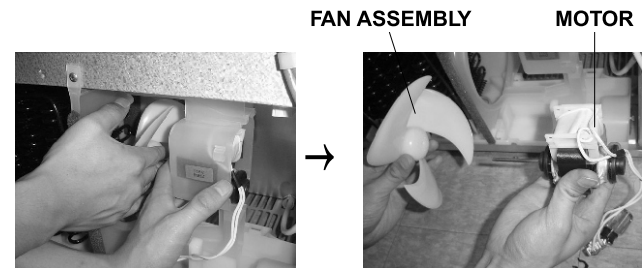

The assembly is in the reverse order of the disassembly and take special care for the following details.

1. Be careful not to bend the tube during assembly.
2. Press the WATER DISPENSER button until water pours out and check for leakage in the CONNECTOR TUBE (It differs by the water pressure but usually takes about 2 minutes until water pours out.)

7. DISPENSER

- 1) Disconnect funnel and button assembly by pulling down and forward.

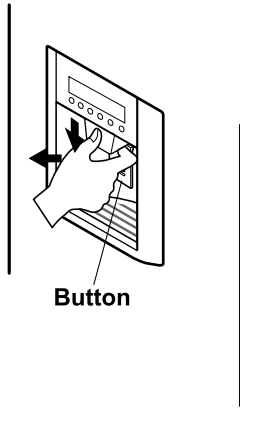

- 4) Loosen four screws with a phillips screwdriver and pull the Funnel Assembly to disconnect.

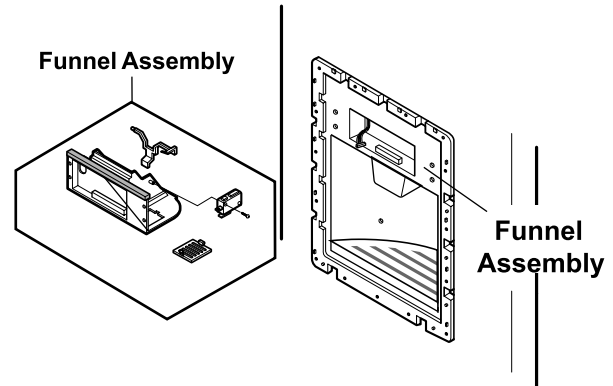

- 2) Remove the Display Frame moving out with both hands in one side and make the same process in the other side and pulling it forward like shows the picture.

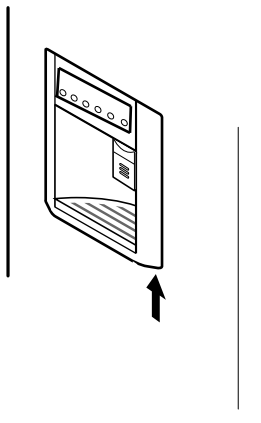

- 3) The Display Assembly can be connected by pressing the top of the Dispenser Cover and pushing it after separating the Display Frame from its housing.

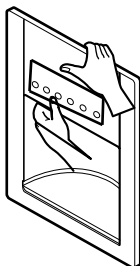

- 5) The Duct Cap Assembly can be disconnected if the hold lever connecting screw is loosened with a phillips driver.

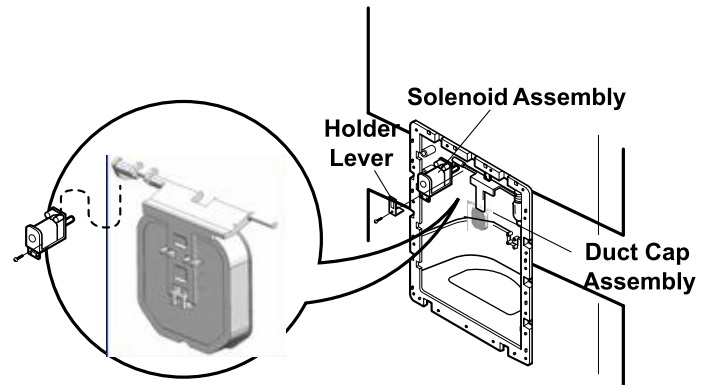

- 6) To install the Duct Cap Assembly, insert one end of the spring into the right hole of the dispenser lever and insert the other end into the right hole in the top part of the dispenser. Then attach the holder at the solenoid switch.

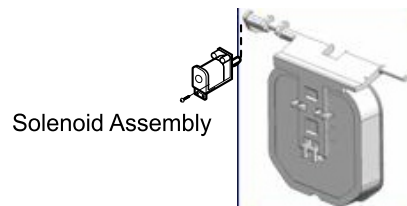

5. MICOM FUNCTION

1. MONITOR PANEL

1-1. Display Second Function

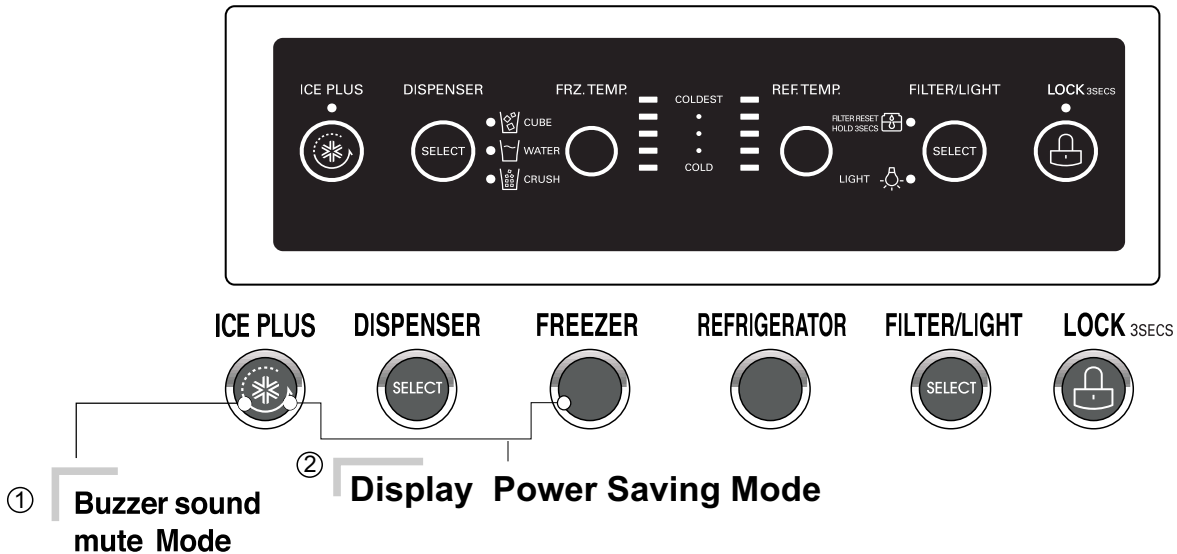

1. Buzzer sound mute Mode

The buzzer sound is set to OFF.

It activates by sounding the recognition sound of “Ding ~” after pressing and holding ICE PLUS” button more than 5 seconds. It inactivates when resetting the mode power.

2. Display OFF mode.

















Display off mode puts the display into standby mode until the door is opened.

To put the display into Display off Mode, press and holds the FRZ. TEMP. and ICE PLUS buttons simultaneously for 5 seconds until the Ding~sounds. (Use both buttons for this to work.) When Display off Mode is activated, the display remains OFF unless a door is opened or a button is pressed. The display will return to the OFF position after 30 seconds inactivity.

To remove the display from Display off Mode, press and hold the FREEZER and ICE PLUS buttons simultaneously for 5 seconds until the Ding~sounds. The Display off Mode default setting is OFF after a power interruption.

2. DESCRIPTION OF FUNCTION

2-1. FUNCTION OF TEMPERATURE SELECTION

Division	Base	1st Press	2nd Press	3rd Press	4th Press
Setting temperature	5 4 3  2  1 	5 4  3  2  1 	5  4  3  2  1 	5 4 3 2  1 	5 4 3 2  1 
Temperature Control	Medium	Medium High	High	Low	Medium Low
Freezer Control	-2°F	-5°F	-8°F	7°F	1°F
Refrigeration Control	37°F	34°F	32°F	46°F	41°F

* The temperature can vary ± 3 C (26.6°F ~ 37.4°F) depending on the load condition.

*** Press the button to cycle through the settings in this order: (Medium) → (Medium High) → (High) → (Low) → (Medium Low).**

- The temperature displayed is the SET temperature, NOT the actual temperature inside the refrigerator. The actual temperature varies, depending upon the temperature of items put into the refrigerator and other variables.
- It takes the refrigerator a while to get down to the set temperature from the initial power-on. Wait at least 24 hours after initial power-up to put food into the refrigerator. If the temperature is unsatisfactory, adjust it and wait 24 hours. It may take three or four days to get the adjustment to your satisfaction.
- The freezer is automatically set to MEDIUM HIGH if the icemaker is set to ON.

2-1-1 Lock Function (dispenser and display button lock)

1. In power application of refrigerator, the LOCK text is turned off at the right side of lock graphic of display with the lock release status.
2. If you wish lock the controls, push on the ALARM/LOCK button for more than 3 seconds, after this time, the LOCK graphic on the display will be turned on.
3. The buzzer sound and control panel and dispenser function is not performed even if pressing display button other than lock key in the lock status.
4. If you wish unlock the controls, press the ALARM/LOCK button more than 3 seconds. The LOCK graphic on the display will be turned off.



2-1-2. Filter condition display function

1. There is a replacement indicator light for the water filter cartridge on the dispenser.
2. Water filter needs replacement once six months.
3. Water filter light and FILTER RESET HOLD 3 SECONDS text turn on to tell you need to replace the filter soon.
4. After replace the filter, press and hold the lock button more than 3 seconds.
Then water filter light and FILTER RESET HOLD 3 SECONDS text turn off with reset status.



2-2. Dispenser use selection

You can select water or ice.

*Please select water, crunched ice, and cubed ice by pressing the  button as you desire.

*Use your cup to press lightly on the actuator.

- Each graphic is indicated for the selected function.
- You'll hear a CLICK when the ice door closes 5 seconds after ice is dispensed.

DISPENSER



REFERENCE : Hold your cup in the dispenser for a few seconds after dispensing ice or water to catch the last few drops or pieces of ice.

Pressing
Switch

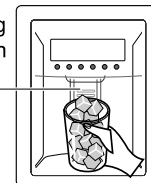

2-3. ICE PLUS

Please select this function for prompt freezer.

- Function is repeated following below whenever pressing ICE PLUS
- The arrow mark graphic remains at the On status after flickering 4 times when selecting Special Refrigeration ICE PLUS.
- ICE PLUS function automatically turns off if a fixed time passes.

ICE PLUS



ICE PLUS



2-4 Dispenser Light

- Dispenser switch or dispenser light button turn the dispenser light in the dispenser on and off.
- The dispenser light Function is repeated following below whenever pressing LIGHT/FILTER button.
- If dispenser light continuously turns on more than 7 minutes with dispenser light button, the dispenser light turns off automatically by compulsion.



2-5 ICE PLUS

1. Ice Plus increases the cooling speed in the freezer by running the fan and the compressor simultaneously.
2. Ice Plus is released if the power fails and is restored.
3. The temperature setting is not changed when Ice Plus is selected.
4. You can change the temperature in the freezer and the refrigerator even if Ice Plus has been selected and is in progress.
5. The refrigerator operates independently of the Ice Plus setting and operation.
6. At the end of the Ice Plus cycle, the freezer defaults to its original setting.
7. If frost removal starting time is arrived during Ice Plus, Ice Plus operation is done only for the remaining time after completion of frost removal when the Ice Plus operation time passes 90 minutes. If passing 90 minutes, Ice Plus operation is done only for 2 hours after completion of frost removal.
8. If pressing Ice Plus button during frost removal, the Ice Plus LCD or LED is turned on but if pressing the Ice Plus, compressor operates after the remaining time has passed.
9. If selection Ice Plus within 7 minutes (delay for 7 minutes of compressor) after the compressor stops, compressor operates after the remaining time has passed.
10. The freezer fan motor operates at the high speed of RPM during operation of Ice Plus.

2-6 Control of variable type of freezing fan

1. To increase cooling speed and load response speed, MICOM variably controls freezing room fan motor at the high speed of RPM and standard RPM.
2. MICOM only operates in the input of initial power or express freezing operation or load response operation for the high speed of RPM and operates in the standard RPM in other general operation.
3. If opening doors of freezing / cold storage room or home bar while fan motor in the freezing room operates, the freezing room fan motor normally operates (If being operated in the high speed of RPM, it converts operation to the standard RPM). However, if opening doors of freezing room or home bar, the freezing room fan motor stops.
4. As for monitoring of BLDC fan motor error in the freezing room, MICOM immediately stops the fan motor by determining that the BLDC fan motor is locked or fails if there would be position signal for more than 115 seconds at the BLDC motor. Then it displays failure (refer to failure diagnosis function table) at the display part of refrigerator, the BLDC motor doesn't operate more. If you want to operate the BLDC motor, turn off and on power resource.

2-7 Control of cooling fan motor

1. The cooling fan motor performs ON/OFF control by linking with the COMP.
2. It controls at the single RPM without varying RPM.
3. Failure sensing method is same as in fan motor of freezing fan motor (refer to failure diagnosis function table for failure display).

2-8. Door opening alarm

1. Buzzer generates alarm sound if doors are not closed even when more than a minute consecutively has passed with doors of freezer / refrigerator or home bar opened.
2. After the door has been open for one minute, the buzzer sounds for 1/2 second and then sounds three times every 30 seconds.
3. If all doors are closed when the alarm sounds, it is cancelled immediately.

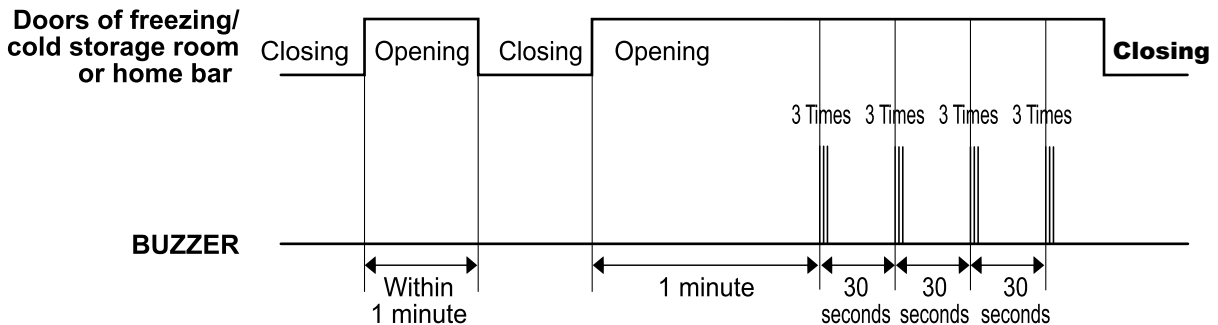

2-9. Ringing of button selection buzzer

1. The ding~ will sound whenever a button is pressed.

2-10 Ringing of compulsory operation, compulsory frost removal buzzer

1. If pressing the test button in the Main PCB, a beep will sound.
2. In selecting compulsory operation, alarm sound is repeated and completed in the cycle of On for 2/10 second and Off for 1 8/10 second three times.
3. In selecting compulsory frost removal, alarm sound is repeated and completed in the cycle of On for 2/10 second , Off for 2/10 second, On for 2/10 second and Off for 1 4/10 second three times.

2-11 Defrost function

1. Defrost is performed whenever total operation time of compressor becomes 7 - 50 hour.
2. In providing initial power (or returning power failure), frost removal starts whenever total operation time of compressor becomes 4 - 5 hours.
3. Defrost is completed if temperature of a defrost sensor becomes more than 5°C after starting defrost. The defrost cycle will fail if the refrigerator does not reach a temperature of 5°C (9°F) two hours into the defrost cycle.
4. The defrost cycle will not operate if the defrost sensor fails, arcs, or shorts cut.

2-12 Refrigerator lamp automatically off

Refrigerator lamp turns on and off by refrigerator door switch.

If refrigerator lamp continuously turns on more than 7 minutes, the refrigerator room lamp turns off automatically period.

2-13 Sequential operation of built-in product

Built-in products such as compressor, frost removal heater, freezing room fan, Cooling Fan and step motor damper are sequentially operated as follows for preventing noise and part damage occurred due to simultaneous operation of a lot of parts in applying initial power and completing test.

Function	Load Operation Sequence	Remark
In applying Initial power	<p>When temperature of a frost removal sensor becomes more than 45° C (113°F) (In purchase, movement)</p>	<p>If error occurs during operation, initial operation is not done.</p> <p>Sequence of load operation when closing Freezer and Refrigerator.</p>
	<p>When temperature of a frost removal sensor becomes less than 45° C (113°F) (In power failure, service)</p>	
TEST MODE	<p>Test mode 1 (Compulsory function)</p>	<p>If pressing switch once more in the test mode 2 or temperature of a frost removal sensor is more than 45 C (113 F), it immediately returns to the test mode for initial operation (COMP operates after 7 minutes).</p>
	<p>Test mode 2 (Compulsory frost removal)</p>	

2-14. Failure Diagnosis Function

1. Failure diagnosis function is to facilitate service when a failure occurs and produces an error code.
2. In occurrence of failure, pressing the function adjustment button does not perform function.
3. If nonconforming matters occurred are released during display of failure code, MICOM returns to the original state (Reset)
4. Failure code is displayed on the display part of setting temperature for the freezing room and the display part of setting temperature for the cold storage room of display, which are placed at the display part of a refrigerator. All the display graphics other than a failure code are turned off.

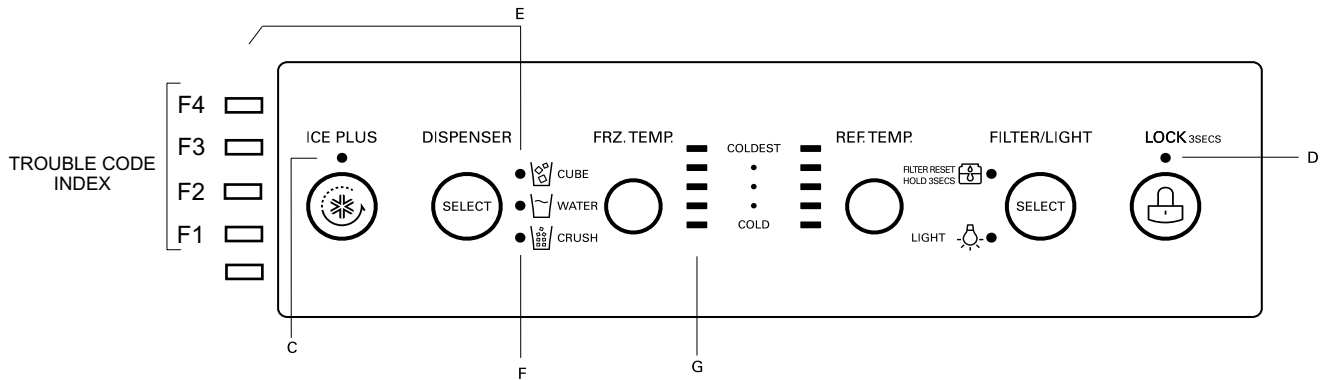

NO	ITEM	TROUBLE CODE INDEX				CONTENTS OF FAILURE	PRODUCT OPERATION STATUS IN FAILURE				
		F1	F2	F3	F4		COMPRESSOR	FREEZING BLDC MOTOR	COOLING BLDC MOTOR	DEFROST HEATER	STEPPING MOTOR DAMPTER
1	ABNORMAL FREEZER SENSOR	○	●	●	●	FREEZER SENSOR SHORT CIRCUIT	ON FOR 15 MINUTES / OFF FOR 15 MINUTES	STANDARD RPM	○	○	○
2	ABNORMAL REFRIGERATOR SENSOR1(R1) (UPPER PART IN THE REFRIGERATOR COMPARTMENT)	●	○	●	●	REFRIGERATOR SENSOR1 SHORT CIRCUIT	○	STANDARD RPM	○	○	FULL OPENING FOR 10 MINUTES/ FULL CLOSING FOR 15 MINUTES
3	ABNORMAL REFRIGERATOR SENSOR2(R2) (UPPER PART IN THE REFRIGERATOR COMPARTMENT)	NORMAL DISPLAY (NOTE 1)				REFRIGERATOR SENSOR2 SHORT CIRCUIT	○	STANDARD RPM	○	○	○
4	ABNORMAL DEFROST SENSOR	●	●	○	●	ABNORMAL SHORT CIRCUIT	○	STANDARD RPM	○	NO DEFROST	○
5	FAILED DEFROSTING	○	○	○	○	DEFROST HEATER, TEMPERATURE FUSE SHORT CIRCUIT, UNPLUGGED CONNECTOR (INDICATED 4 HOURS LATER AFTER TROUBLE)	○	STANDARD RPM	○	○	○
6	ABNORMAL FREEZING BLDC MOTOR	○	●	●	○	MOTOR DEFECT, HOOKED OF LEAD WIRE TO FAN, CONTACT OF STRUCTURES WITH FAN, SHORT OR OPEN OF LEAD WIRE (THERE IS NO SIGNAL OF BLDC MOTOR MORE THAN 65 SECONDS IN OPERATION OF FAN MOTOR)	○	OFF	○	○	○
7	ABNORMAL AMBIENT SENSOR	NORMAL DISPLAY (NOTE 1)				AMBIENT SENSOR SHORT CIRCUIT	○	○	○	○	○
8	ABNORMAL ICEMAKER SENSOR	NORMAL DISPLAY (NOTE 1)				ICEMAKER SENSOR SHORT CIRCUIT	○	○	○	○	○
9	ABNORMAL ICEMAKER UNIT	NORMAL DISPLAY (NOTE 1)				FAULTY ICEMAKER UNIT MOTOR OR HALL IC, LEAD WIRE SHORT CIRCUIT, FAULTY MOTOR DRIVING CIRCUIT	○	○	○	○	○
10	ABNORMAL W/T SENSOR	NORMAL DISPLAY (NOTE 1)				WATER TANK SENSOR SHORT CIRCUIT	○	○	○	○	○

Note1) R2-sensor, OptiChill sensor and water tank sensor, Ice maker-sensor, Ice maker Unit are not indicated on the failure indicating part but indicated in checking Display (When pressing for more than the button of freezing temperature and super freezer button for more than 1 second).

R2-sensor (middle room) or Abnormal Drive Micom Communication	<input type="checkbox"/> Normal: LED or LCD graphic on the (C) part turns on <input type="checkbox"/> Abnormal: LED or LCD graphic on the (C) part turns off	The other LED or LCD Graphics Turn On.
OptChill sensor or Water tank sensor	<input type="checkbox"/> Normal: LED or LCD graphic on the (D) part turns on <input type="checkbox"/> Abnormal: LED or LCD graphic on the (D) part turns off	
Icemaking sensor	<input type="checkbox"/> Normal: LED or LCD graphic on the (E) part turns on <input type="checkbox"/> Abnormal: LED or LCD graphic on the (E) part turns off	
Icemaker unit	<input type="checkbox"/> Normal: LED or LCD graphic on the (F) part turns on <input type="checkbox"/> Abnormal: LED or LCD graphic on the (F) part turns off	
Ambient sensor	<input type="checkbox"/> Normal: LED or LCD graphic on the (G) part turns on <input type="checkbox"/> Abnormal: LED or LCD graphic on the (G) part turns off	

Note 2) Freezer notch temperature display and refrigerator notch temperature display (Failure code indication part) are normally indicated in abnormal ambient sensor, andEr indicated on the ambient temperature display (except for the ambient temperature display, other LEDs or LCDs are indicated normally)

*LCD (LED) check function: If simultaneously pressing express freezer button and freezing temperature adjustment button for a second, the back light is turned on and all display LCD(LED) graphics on. If releasing the button, the LCD (LED) graphic displays the previous status, the back light is turned off (LCD graphic and back light ON/OFF check).

2-15. Test Function

1. The purpose of test function is to check function of the PWB and product and to search for the failure part at the failure status.
2. Test button is placed on the main PCB of refrigerator (test switch), and the test mode will be finished after maximum 2 hours regardless of test mode and then is reset to the normal status.
3. Function adjustment button is not perceived during performance of test mode.
4. In finishing test mode, always pull the power cord out and then plug-in it again for the normal state.
Always wait at least 3 minutes before restarting a compressor to allow the pressures to equalize and to avoid damage.
5. If nonconforming contents such as sensor failure are found during performance of test mode, release the test mode and display the failure code.
6. If you press the TEST button while a failure code is displayed, the test mode will not begin.

Mode	Operation	Contents	Remarks
Test 1	Press test button once (strong cold mode)	<ol style="list-style-type: none"> 1. Continuous operation of compressor 2. Continuous operation of freezing bldc motor (high-speed RPM) and cooling bldc motor 3. Defrost heater turns off 4. Stepping motor damper is completely opened (open of baffle) 5. Optichil stepping motor damper is completely closed. 6. All display LEDs or LCD graphics turn on. 	Freezing fan turns off in door opening.
Test 2	Press test button once at the test mode 1 status (forced defrost mode)	<ol style="list-style-type: none"> 1. Compressor OFF 2. Freezing bldc motor and cooling bldc motor turn off 3. Defrost heater turns on 4. Stepping motor damper is completely closed (closing of baffle) 5. OptiChil stepping motor damper is completely closed. 	Return to the normal mode when the defrost sensor is above +5 °C
Normal Status	Press test button once at the test mode 2 status	Return to the initial status.	Compressor will operate after delay for 7 minutes

LED ALL ON

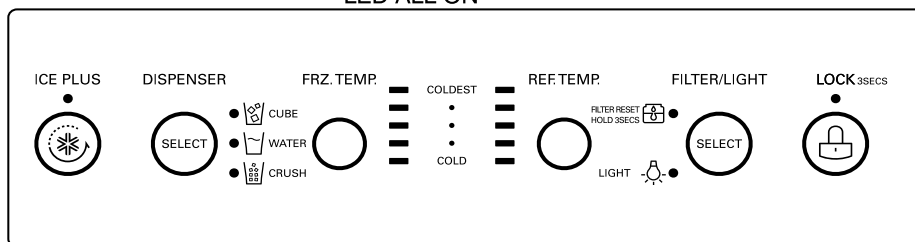

Only LED F, R MIDDLE NOTCH ON

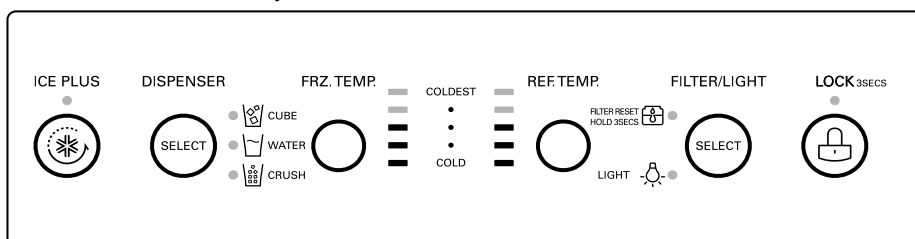

2.16. Function of dispenser and water dispenser built-in

1. The dispenser allows ice and water to be served without opening the freezer door.
2. Press the dispenser switch (the rubber button) after selecting crushed ice, cubed ice, or water. The dispenser door will open automatically. It will close automatically 5 seconds after dispensing is completed, and you will hear the CLICK.
3. The dispenser will not operate when the freezer door is open.
4. The ice dispenser will automatically stop after 3 minutes even without an OFF signal. The ice door will close automatically 5 seconds after that, and you will hear the CLICK.
5. Dispenser Lamp ON/ OFF Function.
The dispenser lamp is operated in conjunction with the dispenser switch. It comes on when ice or water is dispensed, and turns off when dispensing is completed.
6. Selection function of water/crushed/cube ice
 - 1) This allows the selection of water/cubed/crushed ice. Press the button to cycle through WATER→ CRUSHED →CUBED.
 - 2) At initial power-on, the dispenser defaults to CUBED ICE.
 - 3) When CUBE ICE is selected, the geared motor rotates so CUBED ICE is dispensed.
 - 4) When CRUSHED ICE is selected, the geared motor rotates in the opposite direction so CRUSHED ICE is dispensed.
7. Water dispenser function
 - 1) Select WATER to dispense water.
 - 2) The water line is a direct connection to the household water supply. If water is selected at the dispenser, a solenoid opens and allows water to flow. A similar solenoid is operated in conjunction with the icemaker to fill it at the appropriate time in its cycle.

6. EXPLANATION FOR MICOM CIRCUIT

1. Explanation for PWB circuit

1-1. Power circuit

The power circuit includes a Switched Mode Power Supply (SMPS). It consists of a rectifier (BD1 and CE1) converting AC to DC, a switch (IC2) switching the DC voltage, a transformer, and a feedback circuit (IC3 and IC4).

Caution : Since high voltage (160 Vdc) is maintained at the power terminal, wait at least 3 minutes after unplugging the appliance to check the voltages to allow the current to dissipate.

Voltage of every part is as follows:

Part	VA1	CE1	CE2	CE3	CE4	CE5
Voltage	120 Vac	160 Vdc	14 Vdc	12 Vdc	15.5 Vdc	5 Vdc

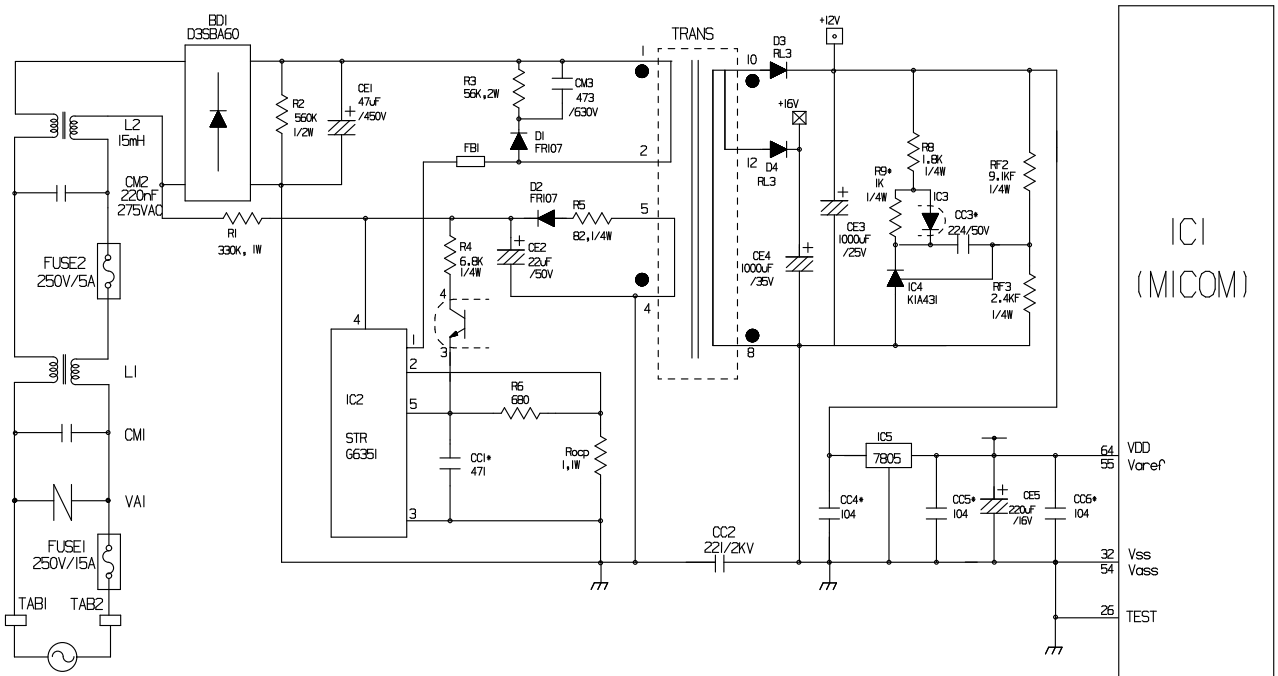

1-2. Oscillation circuit

The oscillation circuit generates a basic clock signal for synchronization and time calculation related to the transmission of data and calculations made by the MICOM (IC1). The oscillator (OSC1) must always be replaced with an exact rated part, because if this spec is changes, the time calculations of the MICOM will be affected and it might not work at all.

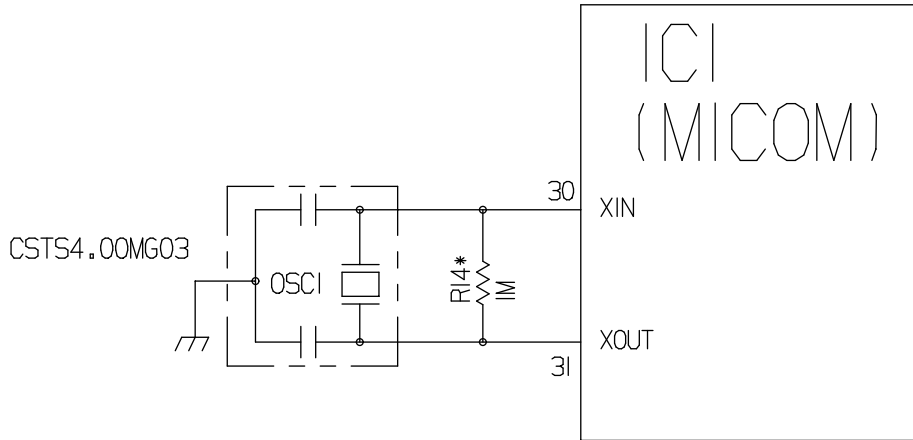

1-3. Reset circuit

The RESET circuit allows various parts of the MICOM, such as RAM, defrosting, etc., to be restarted from the initial state when power is interrupted or restored. A LOW signal applied to the reset terminal for 10 ms causes the MICOM to reset itself. During normal operation, the voltage at the reset terminal is 5 Vdc. If the reset fails, the MICOM will not operate.

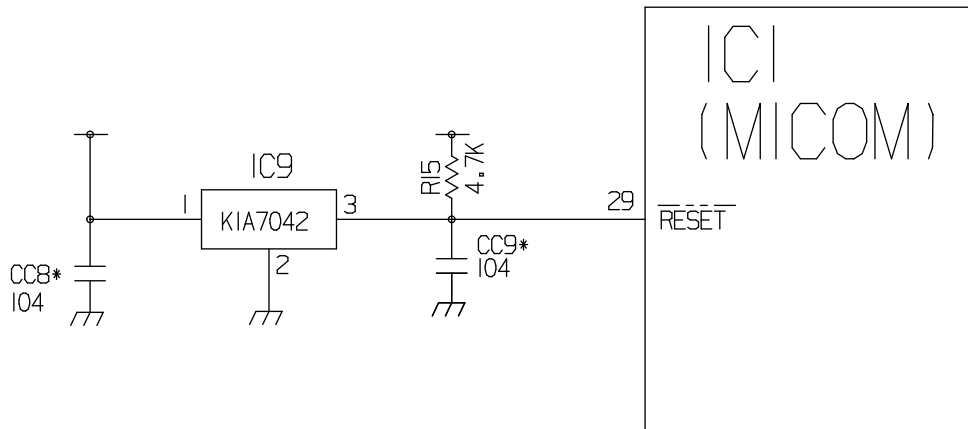

1-4. Load/dispenser operation, door opening circuit

1. LOAD DRIVING CIRCUIT

- The fan operates at the regular speed even if the door of the refrigerator or freezer is opened. When the doors are closed, the fan reverts to its original speed.
- (A), (B), (C), and (D) of door switch for the freezer or refrigerator are connected to the door open sensing circuit in parallel toward both ends of switch to determine door open at MICOM.
- In the TEST mode, the fan will stop if any door is opened. It will resume operation when the door is closed.

Type of Load	Compressor	Frost Removal Heater	AC Converting Relay	Refrigerator LAMP	Dispenser Heater
Measuring part (IC6)	IC6-16	IC6-13	IC6-12	IC6-15	IC6-14
Status	ON	Within 1 V			
	OFF	12 V			

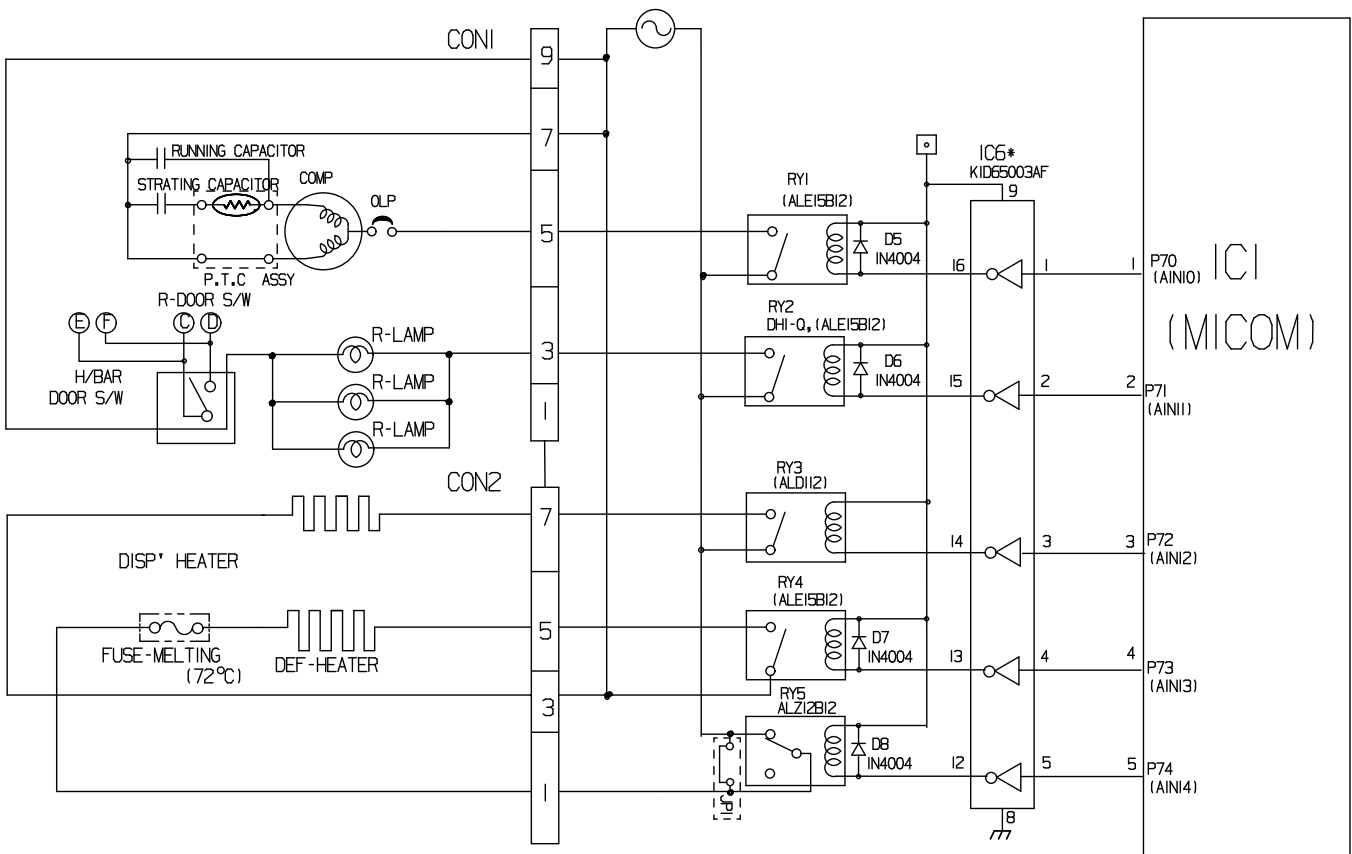

2. Dispenser operation circuit

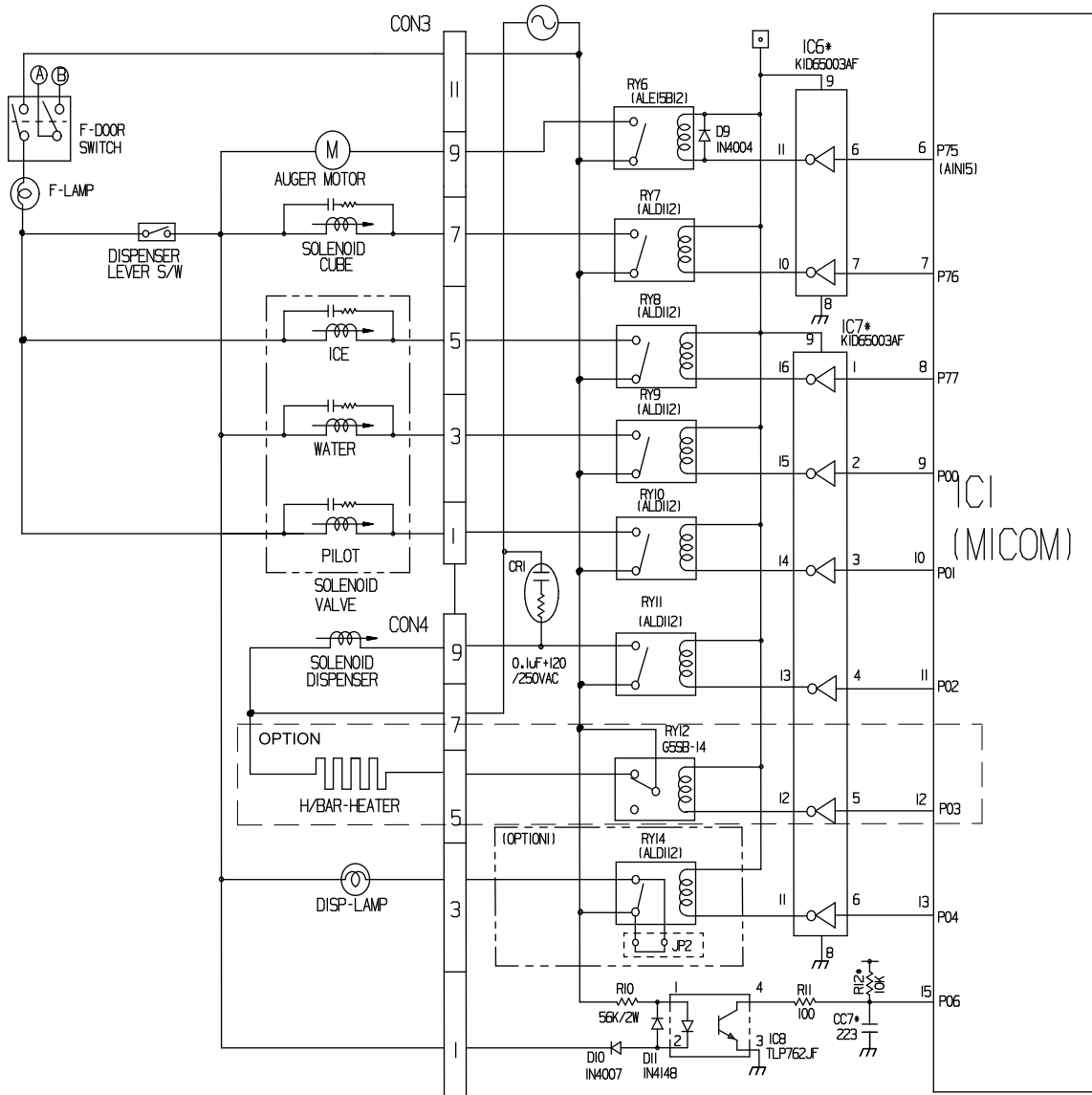

1) Check load driving status

Type of Load	GEARED MOTOR	SOLENOID CUBE	WATER VALVE	SOLENOID DISPENSER
			WATER	
Measuring part	IC6-11	IC6-10	IC7-15	IC7-13
Status	ON	Within 1 V		
	OFF	12 V		

2) Lever Switch sensing circuit

Measuring part	IC1 (MICOM) (No. 16)	
Lever S/W		
ON (Press)	5 V	(60 Hz)
OFF	0 V	5V

3. Door opening sensing circuit

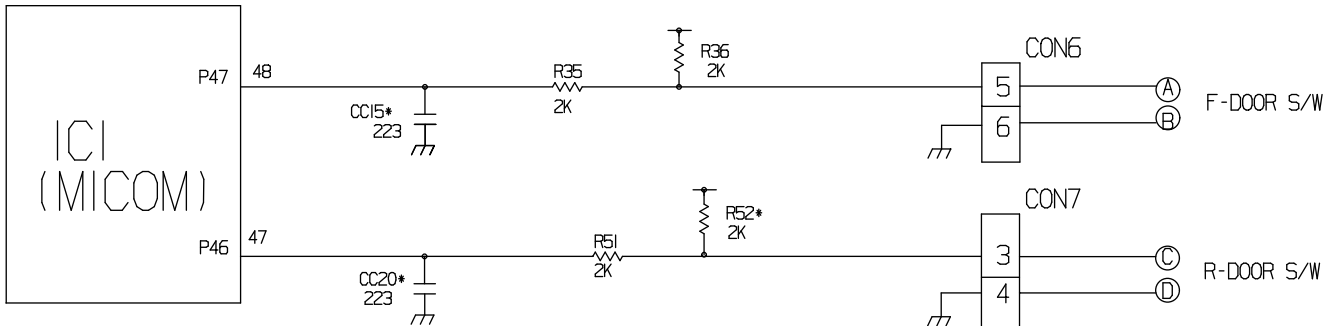

Measuring part	IC1 (MICOM) No. (44, 45) / (45, 46) / (47, 48) Pin
Door of Freezer / Refrigerator	
Closing	5 V (A) - (B), (C) - (D). Switch at both ends are at OFF status)
Opening	0 V (A) - (B), (C) - (D). Switch at both ends are at ON status)

*Since door switches (A) and (B) are interconnected, if either fails, the other will not respond properly.

*If either switch fails, the light will not come on.

1-5. Temperature sensing circuit

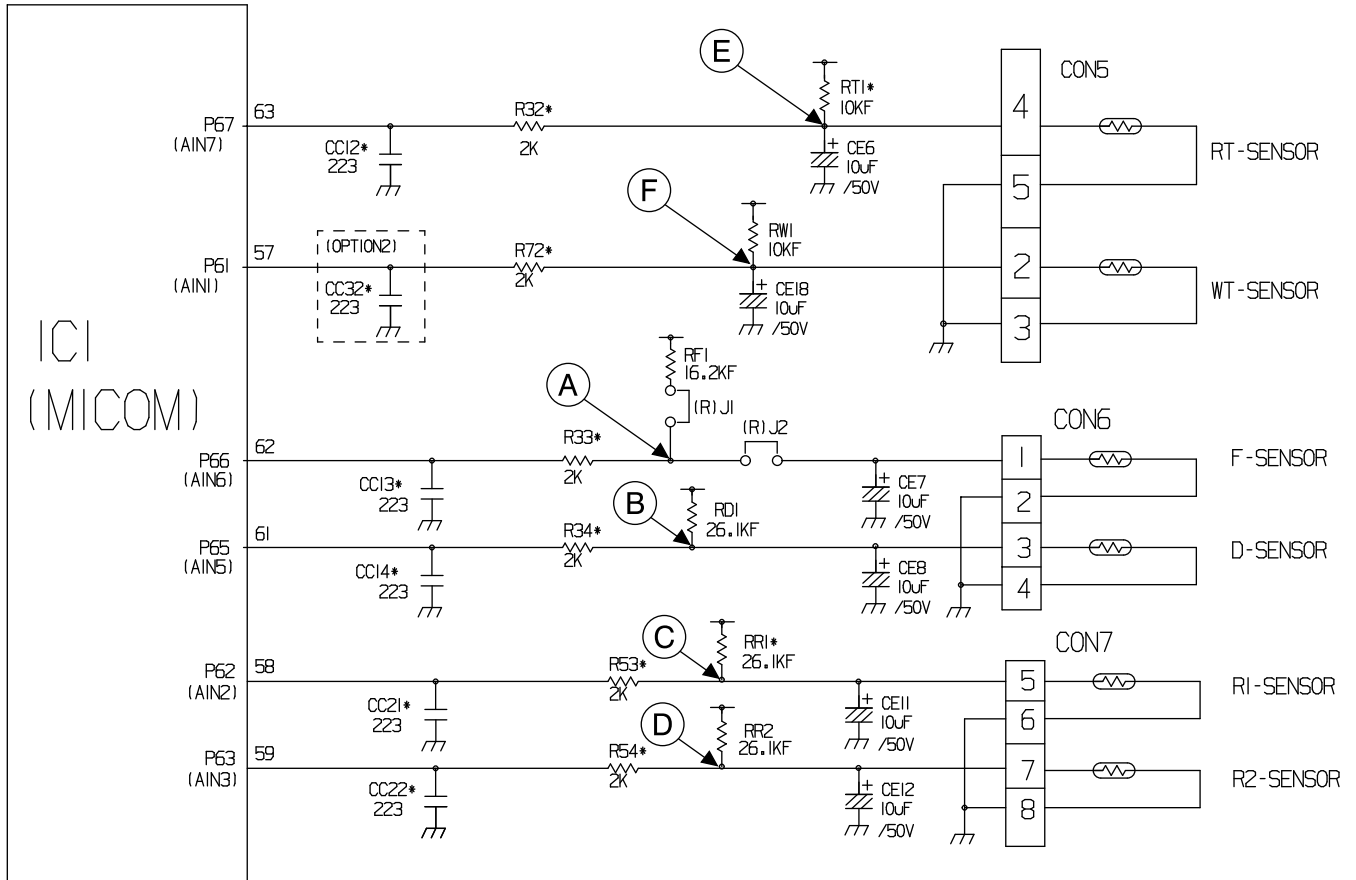

The circuits involving the freezer and refrigerator sensors control the temperature in both the freezer and the refrigerator. The Icemaker sensor detects when ice is made. The defrost sensor determines both the need for defrosting and the efficiency of the defrost operation. See the table below for voltages and checkpoints.

SENSOR	CHECK POINT	NORMAL(-30°C ~ 50°C)	IN SHORT	IN OPEN
Freezing sensor	POINT ① Voltage	0.5 V~4.5 V	0 V	5 V
Defrost sensor	POINT ② Voltage			
Refrigerator sensor 1	POINT ③ Voltage			
Refrigerator sensor 2	POINT ④ Voltage			
Room temperature sensor	POINT ⑤ Voltage			
Water tank sensor	POINT ⑥ Voltage			
Optichill sensor	POINT ⑦ Voltage			

1-6. Switch entry circuit

The following circuits are sensing signals from the test switch, damper motor reed switch for testing and diagnosing the refrigerator.

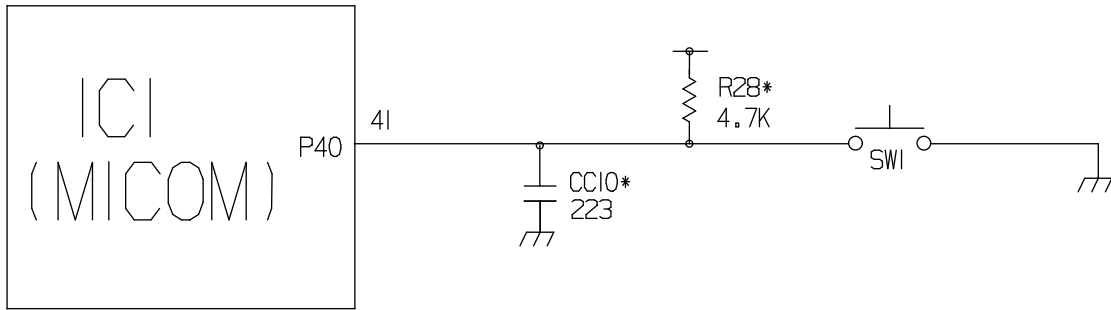

1-7. Option designation circuit (model separation function)

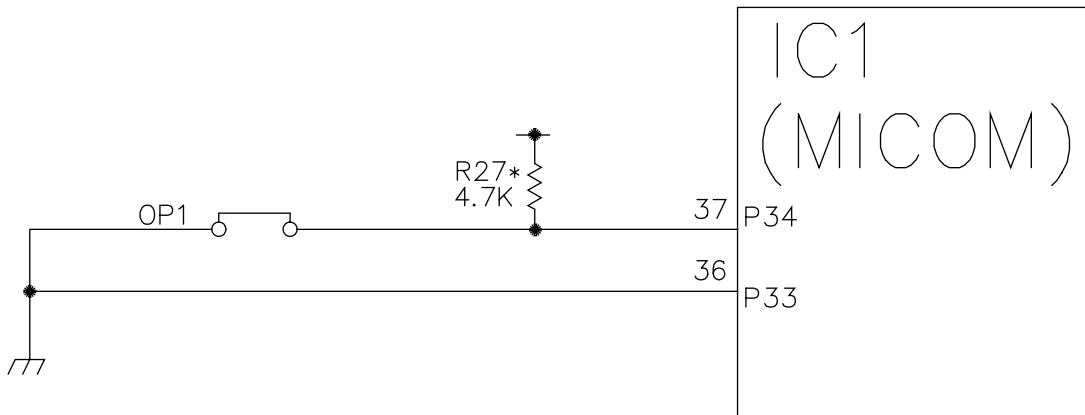

1-8. Stepping motor operation circuit

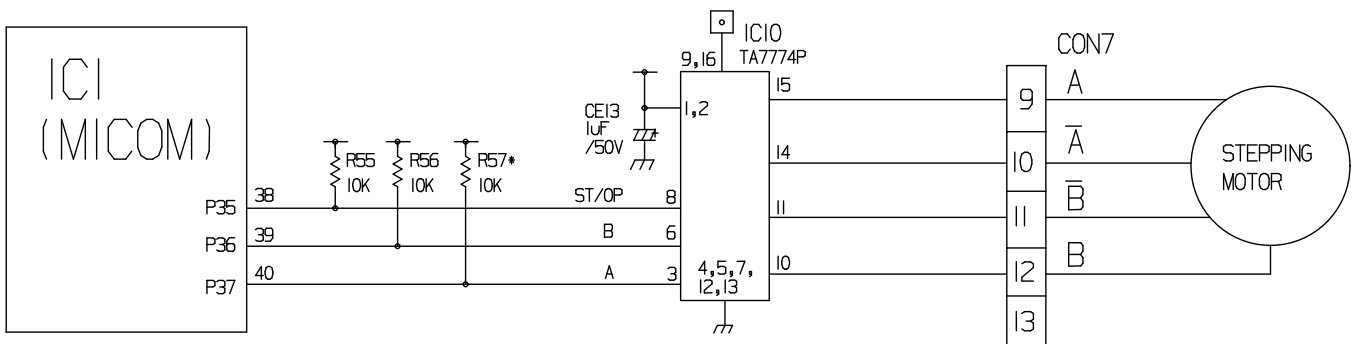

The motor is driven by magnetism formed in the areas of the coils and the stator. Rotation begins when a HIGH signal is applied to MICOM Pin 33 of IC10 (TA7774F). This causes an output of HIGH and LOW signals on MICOM pins 34 and 35.

Explanation) The stepping motor is driven by sending signals of 3.33 mSEC via MICOM pins 33, 34, and 35, as shown in the chart below. These signals are output via terminals 10, 11, 14, and 15 via input terminals 3, 6, and 8 of IC10 (TA7774F), the motor drive chip. The output signals allow the coils wound on each phase of the stator to form a magnetic field, which causes rotation. Input to the terminals INA and INB of IC10 as shown in the chart below drives the motor.

CCW (Reverse rotation) ← → (Positive rotation) CW

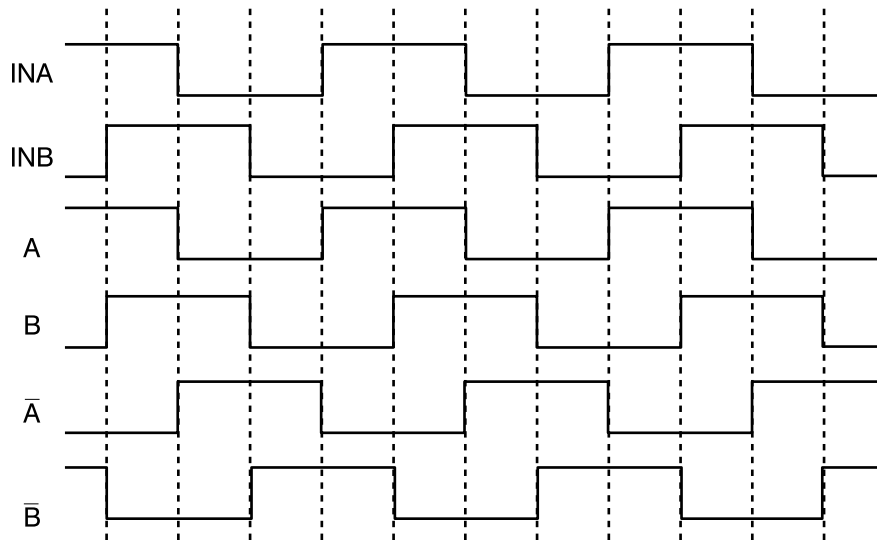

1-9. Fan motor driving circuit (freezer, mechanical area)

1. The circuit cuts all power to the fan drive IC, resulting in a standby mode.
2. This circuit changes the speed of the fan motor by varying the DC voltage between 7.5 Vdc and 16 Vdc.
3. This circuit stops the fan motor by cutting off power to the fan when it senses a lock-up condition.

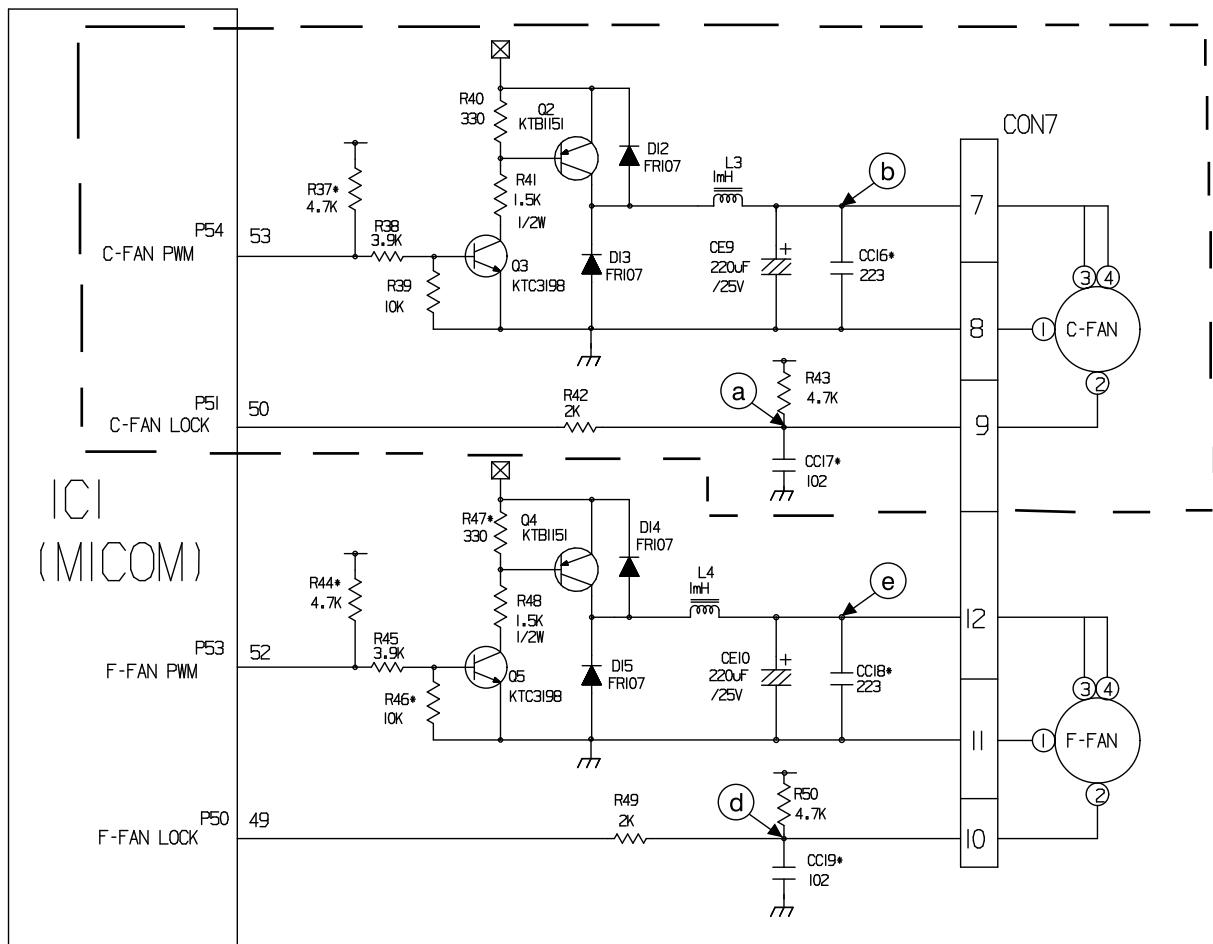

	Ⓐ, Ⓓ part	Ⓑ part	Ⓔ part
Motor OFF	5V	2V or less	2V or less
Motor ON	2 ~ 3V	12 ~ 14V	8 ~ 16V

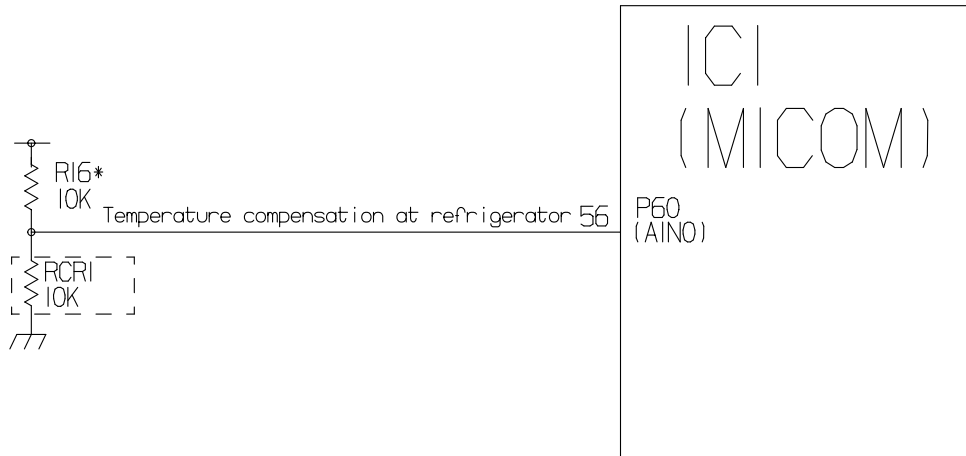

1-10. Temperature compensation and temperature compensation circuit

1. Temperature compensation in freezer and refrigerator



Freezer		Refrigerator		Remarks
Resistance value (RCF1)	Temperature compensation	Resistance value (RCR1)	Temperature compensation	
180 kΩ	+5°C [+9 °F]	180 kΩ	+2.5°C [+4.5 °F]	Warmer 
56 kΩ	+4°C [+7.2°F]	56 kΩ	+2.0°C [+3.6 °F]	
33 kΩ	+3°C [+5.4°F]	33 kΩ	+1.5°C [+2.7 °F]	
18 kΩ	+2°C [+3.6°F]	18 kΩ	+1.0°C [+1.8 °F]	
12 kΩ	+1°C [+1.8°F]	12 kΩ	+0.5°C [+0.9 °F]	
10 kΩ	0 °C [0°F]	10 kΩ	0 °C [0°F]	Reference temperature
8.2 kΩ	-1°C [-1.8 °F]	8.2 kΩ	-0.5 °C [-0.9 °F]	 Cooler
5.6 kΩ	-2°C [-3.6 °F]	5.6 kΩ	-1.0 °C [-1.8 °F]	
3.3 kΩ	-3°C [-5.4 °F]	3.3 kΩ	-1.5 °C [-2.7 °F]	
2 kΩ	-4°C [-7.2 °F]	2 kΩ	-2.0 °C [-3.6 °F]	
470 Ω	-5°C [-9 °F]	470 Ω	-2.5°C [-4.5 °F]	

•Temperature compensation table by adjustment value (difference value against current temperature)

Ex) If you change compensation resistance at the refrigerator (RCR1) from 10 kΩ (current resistance) to 18 kΩ (modified resistance), the temperature at the refrigerator will increase by +1 °C[+1.8°F].

•Temperature compensation table at the refrigerator is as follows:

	Modification resistance	470 Ω	2 kΩ	3.3 kΩ	5.6 kΩ	8.2 kΩ	10 kΩ	12 kΩ	18 kΩ	33 kΩ	56 kΩ	180 kΩ
	Current resistance											
Refrigerator (RCR1)	470Ω	No change	0.5°C [0.9°F] Up	1°C [1.8°F] Up	1.5°C [2.7°F] Up	2°C [3.6°F] Up	2.5°C [4.5°F] Up	3°C [5.4°F] Up	3.5°C [6.3°F] Up	4°C [7.2°F] Up	4.5°C [8.1°F] Up	5°C [9°F] Up
	2 kΩ	0.5°C [0.9°F] Down	No change	0.5°C [0.9°F] Up	1°C [1.8°F] Up	1.5°C [2.7°F] Up	2°C [3.6°F] Up	2.5°C [4.5°F] Up	3°C [5.4°F] Up	3.5°C [6.3°F] Up	4°C [7.2°F] Up	4.5°C [8.1°F] Up
	3.3 kΩ	1°C [1.8°F] Down	0.5°C [0.9°F] Down	No change	0.5°C [0.9°F] Up	1°C [1.8°F] Up	1.5°C [2.7°F] Up	2°C [3.6°F] Up	2.5°C [4.5°F] Up	3°C [5.4°F] Up	3.5°C [6.3°F] Up	4°C [7.2°F] Up
	5.6 kΩ	1.5°C [2.7°F] Down	1°C [1.8°F] Down	0.5°C [0.9°F] Down	No change	0.5°C [0.9°F] Up	1°C [1.8°F] Up	1.5°C [2.7°F] Up	2°C [3.6°F] Up	2.5°C [4.5°F] Up	3°C [5.4°F] Up	3.5°C [6.3°F] Up
	8.2 kΩ	2°C [3.6°F] Down	1.5°C [2.7°F] Down	1°C [1.8°F] Down	0.5°C [0.9°F] Drop	No change	0.5°C [0.9°F] Up	1°C [1.8°F] Up	1.5°C [2.7°F] Up	2°C [3.6°F] Up	2.5°C [4.5°F] Up	3°C [5.4°F] Up
	10 kΩ	2.5°C [4.5°F] Down	2°C [3.6°F] Down	1.5°C [2.7°F] Down	1°C [1.8°F] Down	0.5°C [0.9°F] Down	No change	0.5°C [0.9°F] Up	1°C [1.8°F] Up	1.5°C [2.7°F] Up	2°C [3.6°F] Up	2.5°C [4.5°F] Up
	12 kΩ	3°C [5.4°F] Down	2.5°C [4.5°F] Down	2°C [3.6°F] Down	1.5°C [2.7°F] Down	1°C [1.8°F] Down	0.5°C [0.9°F] Down	No change	0.5°C [0.9°F] Up	1°C [1.8°F] Up	1.5°C [2.7°F] Up	2°C [3.6°F] Up
	18 kΩ	3.5°C [6.3°F] Down	3°C [5.4°F] Down	2.5°C [4.5°F] Down	2°C [3.6°F] Down	1.5°C [2.7°F] Down	1°C [1.8°F] Down	0.5°C [0.9°F] Down	No change	0.5°C [0.9°F] Up	1°C [1.8°F] Up	1.5°C [2.7°F] Up
	33 kΩ	4°C [7.2°F] Down	3.5°C [6.3°F] Down	3°C [5.4°F] Down	2.5°C [4.5°F] Down	2°C [3.6°F] Down	1.5°C [2.7°F] Down	1°C [1.8°F] Down	0.5°C [0.9°F] Down	No change	0.5°C [0.9°F] Up	1°C [1.8°F] Up
	56 kΩ	4.5°C [8.1°F] Down	4°C [7.2°F] Down	3.5°C [6.3°F] Down	3°C [5.4°F] Down	2.5°C [4.5°F] Down	2°C [3.6°F] Down	1.5°C [2.7°F] Down	1°C [1.8°F] Down	0.5°C [0.9°F] Down	No change	0.5°C [0.9°F] Up
180 kΩ	5°C [9°F] Down	4.5°C [8.1°F] Down	4°C [7.2°F] Down	3.5°C [6.3°F] Down	3°C [5.4°F] Down	2.5°C [4.5°F] Down	2°C [3.6°F] Down	1.5°C [2.7°F] Down	1°C [1.8°F] Down	0.5°C [0.9°F] Down	No change	

•Temperature compensation at the freezer is performed the same as at the refrigerator. The value for the freezer is twice that of the refrigerator.

•This circuit enters the necessary level of temperature compensation for adjusting the appliance. The method is the same for every model in this appliance family.

Key Button Input & Display Light-On Circuit

The circuit shown determines whether a function control key on the operation display is pushed. It also turns on the corresponding function indication LED DISPLAY. The drive is the scan type.

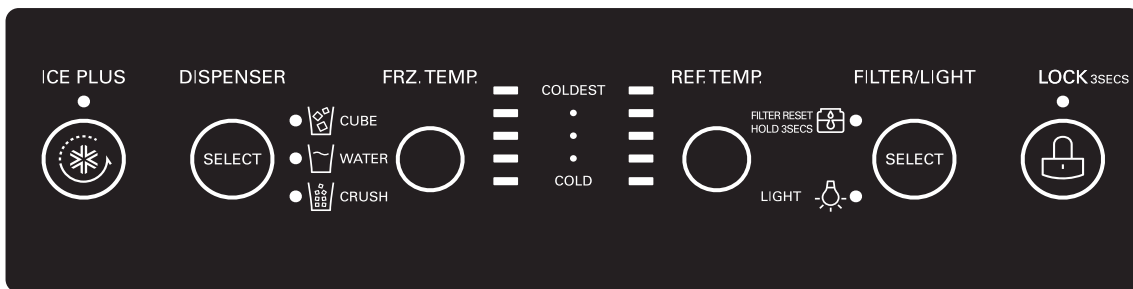
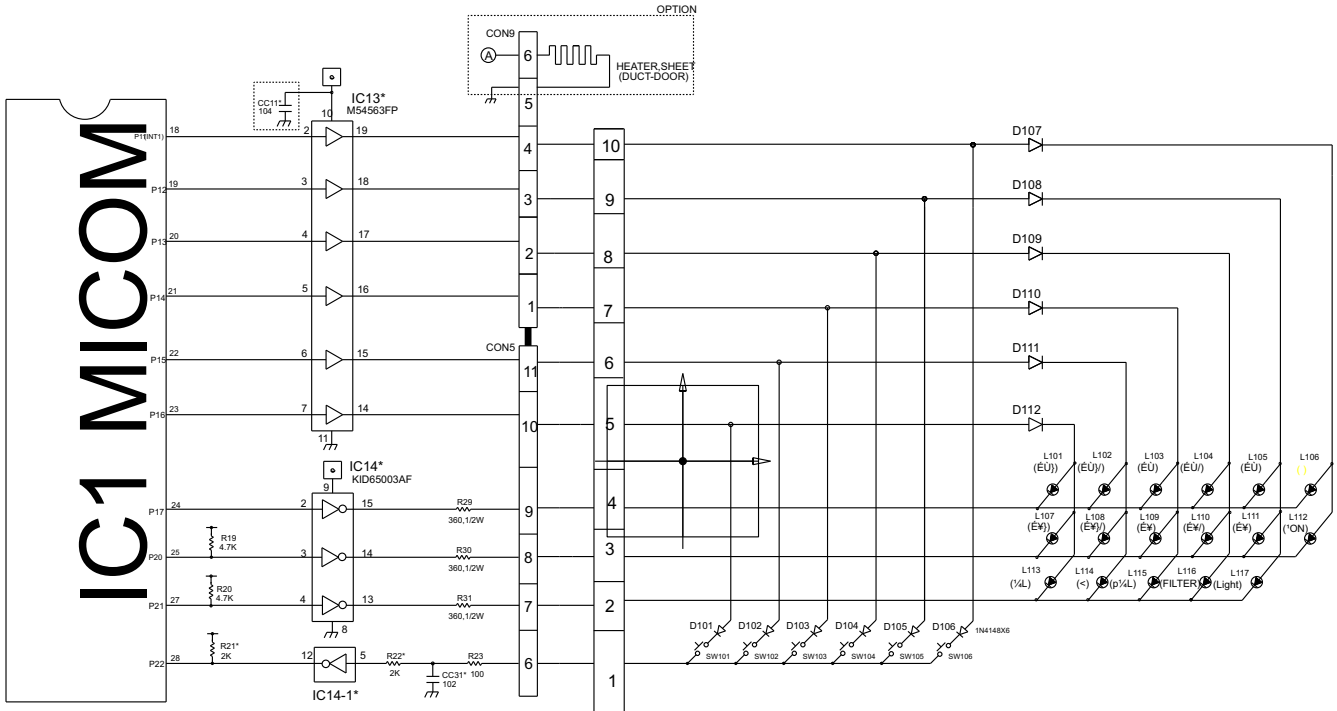

2) Sensor resistance characteristics table

Measuring Temperature (°C)	Measuring Temperature (°F)	Freezing Sensor	Cold storage sensor 1 & 2 Frost removal sensor, Outside sensor
-20°C	-4 °F	22.3 kΩ	77 kΩ
-15°C	+5°F	16.9 kΩ	60 kΩ
-15°C	+14°F	13.0 kΩ	47.3 kΩ
-5 °C	+23 °F	10.1 kΩ	38.4 kΩ
0 °C	+32°F	7.8 kΩ	30 kΩ
+5°C	+41°F	6.2 kΩ	24.1 kΩ
+10°C	+50°F	4.9 kΩ	19.5 kΩ
+15 °C	+59 °F	3.9 kΩ	15.9 kΩ
+20°C	+68°F	3.1 kΩ	13 kΩ
+25°C	+77°F	2.5 kΩ	11 kΩ
+30°C	+86°F	2.0 kΩ	8.9 kΩ
+40°C	+104°F	1.4 kΩ	6.2 kΩ
+50°C	+122°F	0.8 kΩ	4.3 kΩ

- ▶ Resistance value allowance of sensor is $\pm 5\%$.
- ▶ When measuring the resistance value of the sensor, allow the temperature of that sensor to stabilize for at least 3 minutes before measuring. This delay is necessary because of the sense speed relationship.
- ▶ Use a digital tester to measure the resistance. An analog tester has to great a margin of error.
- ▶ Resistance of the cold storage sensor 1 and 2 shall be measured with a digital tester after separating CON8 of the PWB ASSEMBLY and the MAIN part.
- ▶ Resistance of the freezing sensor shall be measured with a digital tester after separating CON7 of the PWB ASSEMBLY and the MAIN part.

2. PWB parts diagram and list

2-1. PWB Assembly, main part diagram

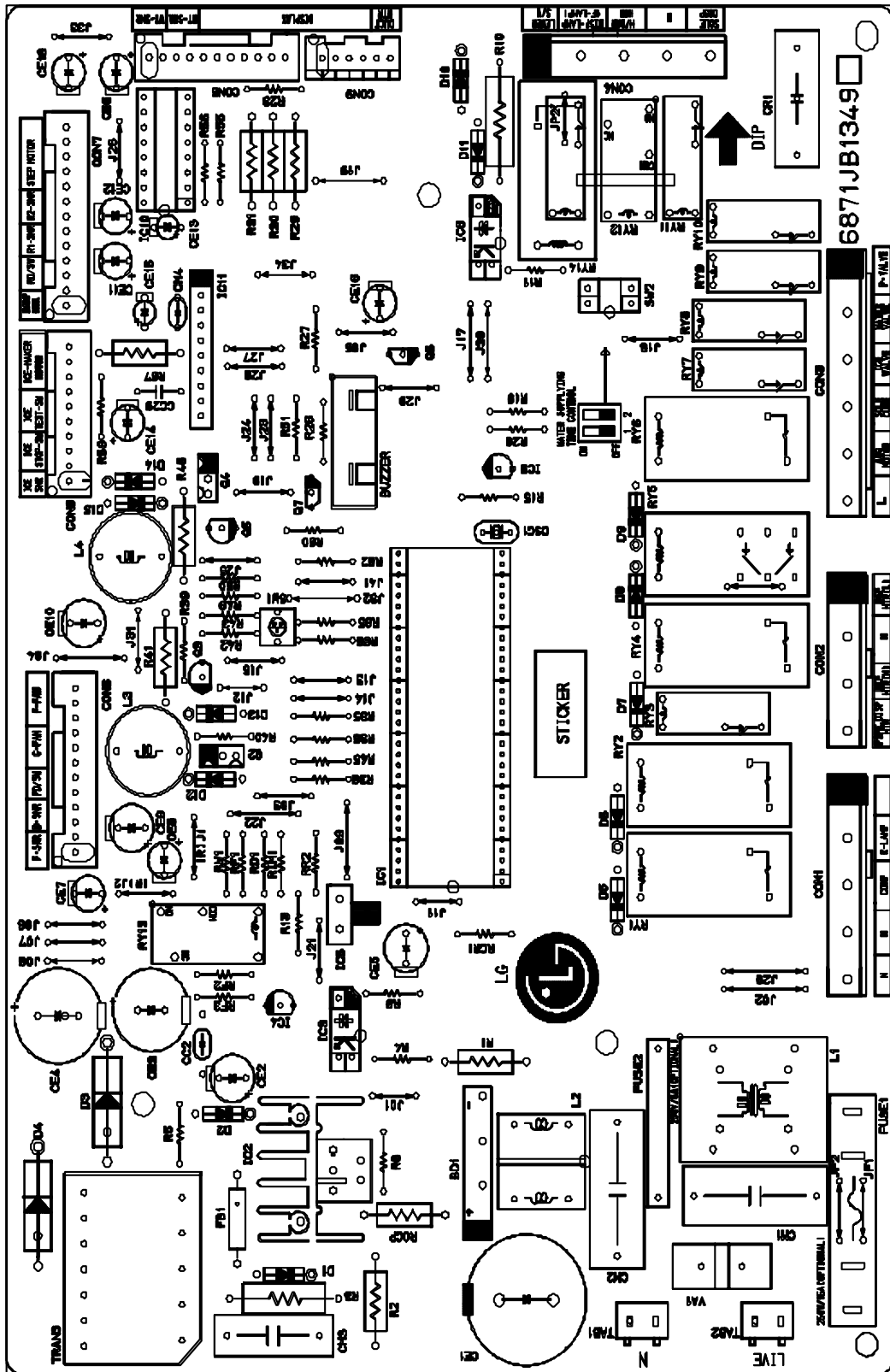

2-2 PWB Display

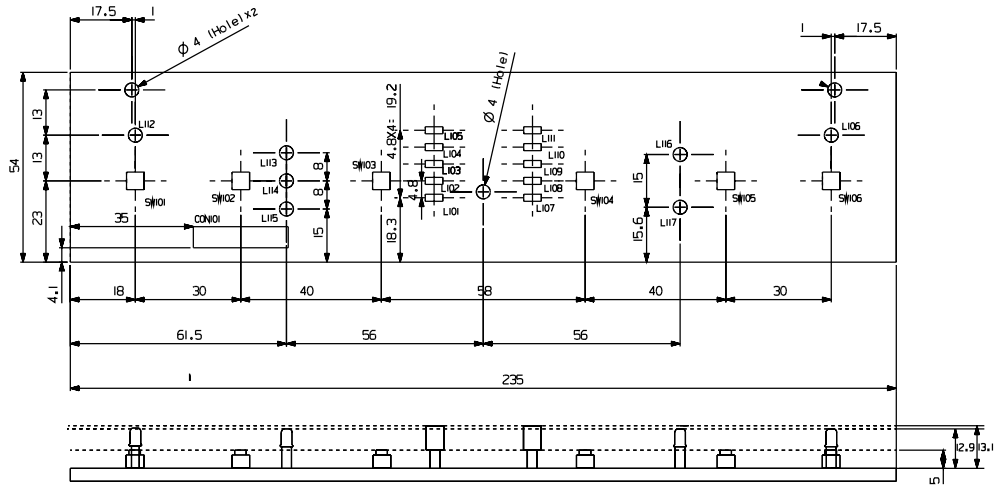

B	A	WORK					
TOWPJT LED DISPLAY	TOWPJT LED D DISPLAY	APPLICATION					
Qty	Qty	No	P/No	DESCRIPTION	SPEC	MAKER	REMARK
-	1	1	6870JB9212A	PWBPCBI	TOW PJT LED DISPLAY	-	-
-	-	2	6870JB9212B	PWBPCBI	TOW PJT LED DISPLAY VER 4.0	-	-
-	-	3	-	-	-	-	-
-	-	4	-	REFLECTOR	-	-	-
-	-	5	-	NAME PLATE, PIHJ	-	-	-
-	-	6	-	-	-	-	-
-	-	7	-	-	-	-	-
-	-	8	-	-	-	-	-
1	1	9	6630JB8004J	CONNECTOR (CIRCI, WAFER)	SMN250 YECNHO ICP 2.5MM STRAIGHT SN	YEON HD	CON101
-	-	10	-	-	-	-	-
-	-	11	-	-	-	-	-
6	6	12	005414B09AB	DIODE, SWITCHING	RLS4148 ROHW TP LLDSILL - 341 75V NA NA 4NSEC 450MA	RDHM	DI01..I06
-	-	13	-	-	-	-	-
10	10	14	0DLLE0148AA	LED	LT5221-41 GREEN	LEDTECH	L101..I05,I07..III
-	-	15	0DLLEC019AC	LED	LT5221-81-HE-BCM GREEN	LEDTECH	L106..I12..I17
-	-	16	0DLLE0195AA	LED	LT0521-81-BCV	LEDTECH	L106..I12..I17
6	6	17	6600RRT002J 6600RRT005A	SWITCH, TACT	JPT1139A JEIL 12VDC 50MA SMD KPS-1105AM	JEIL KYUINGIN	SW101..I06
6	-	18	0DD400409AC	DIODE, RECTIFIERS	1N4CC4 40CV 1.1V 5UA 30A-D041 TP ZP I	ACTRONIX	DI07-D11Z

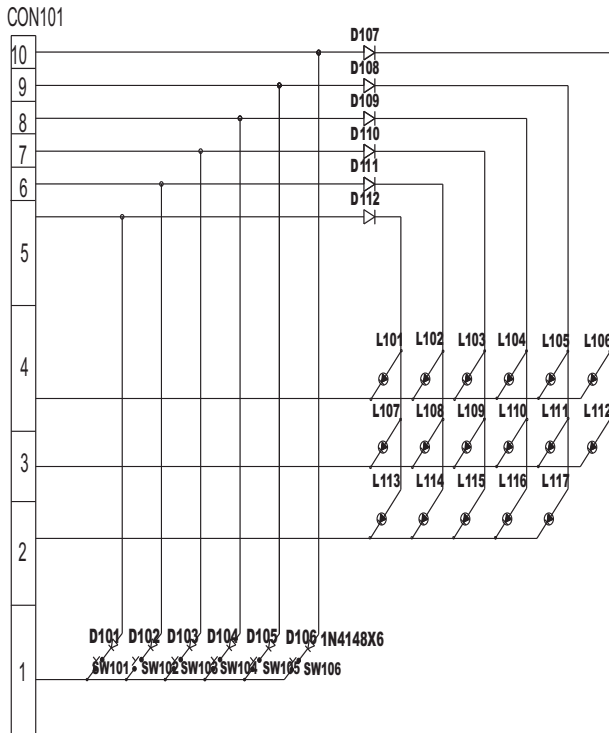

2-3 PWB Main Assembly

Part 1

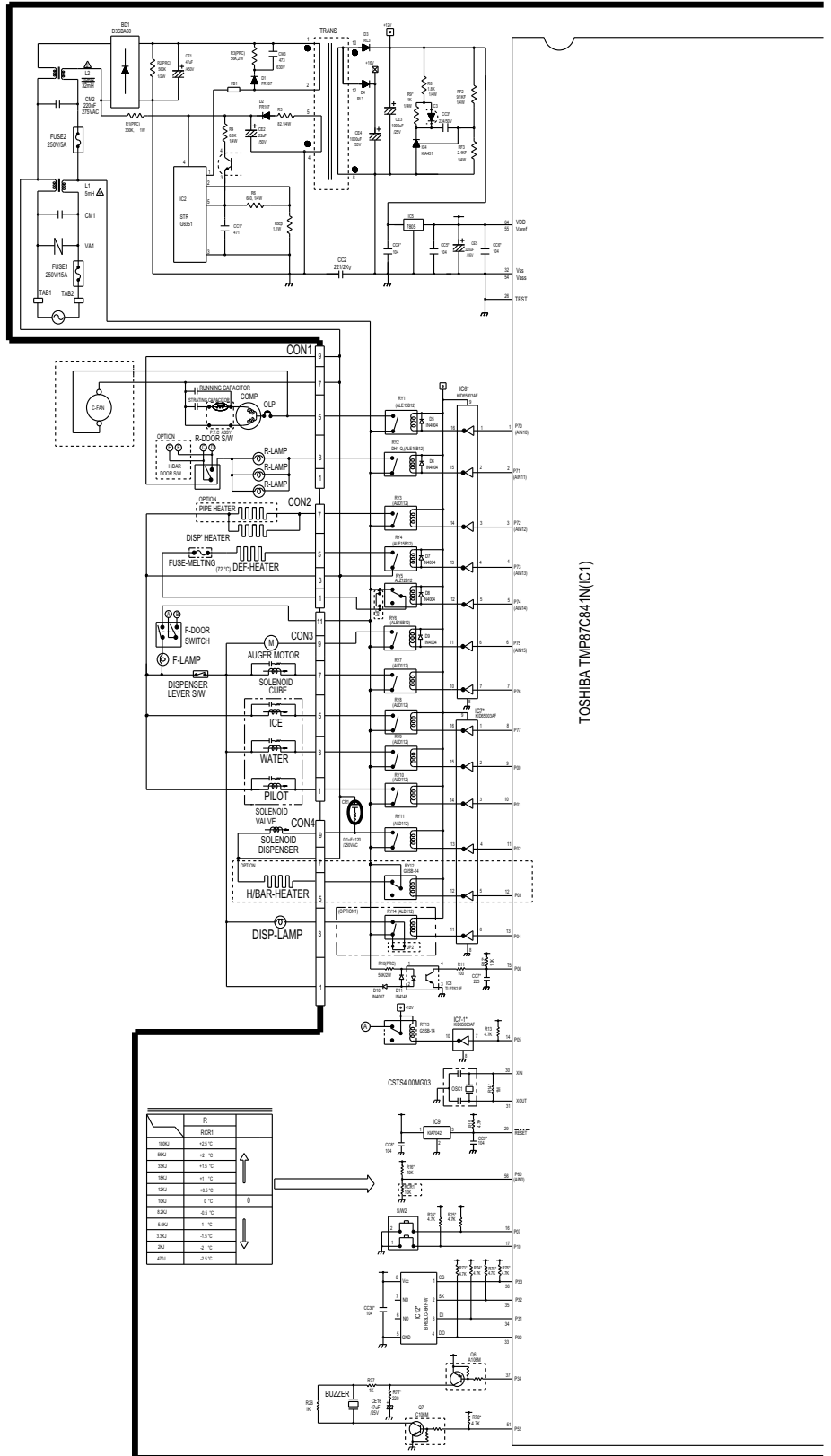

TOSHIBA TMP87C841N(C1)

Part 2

TOSHIBA TMP87C841N(C1)

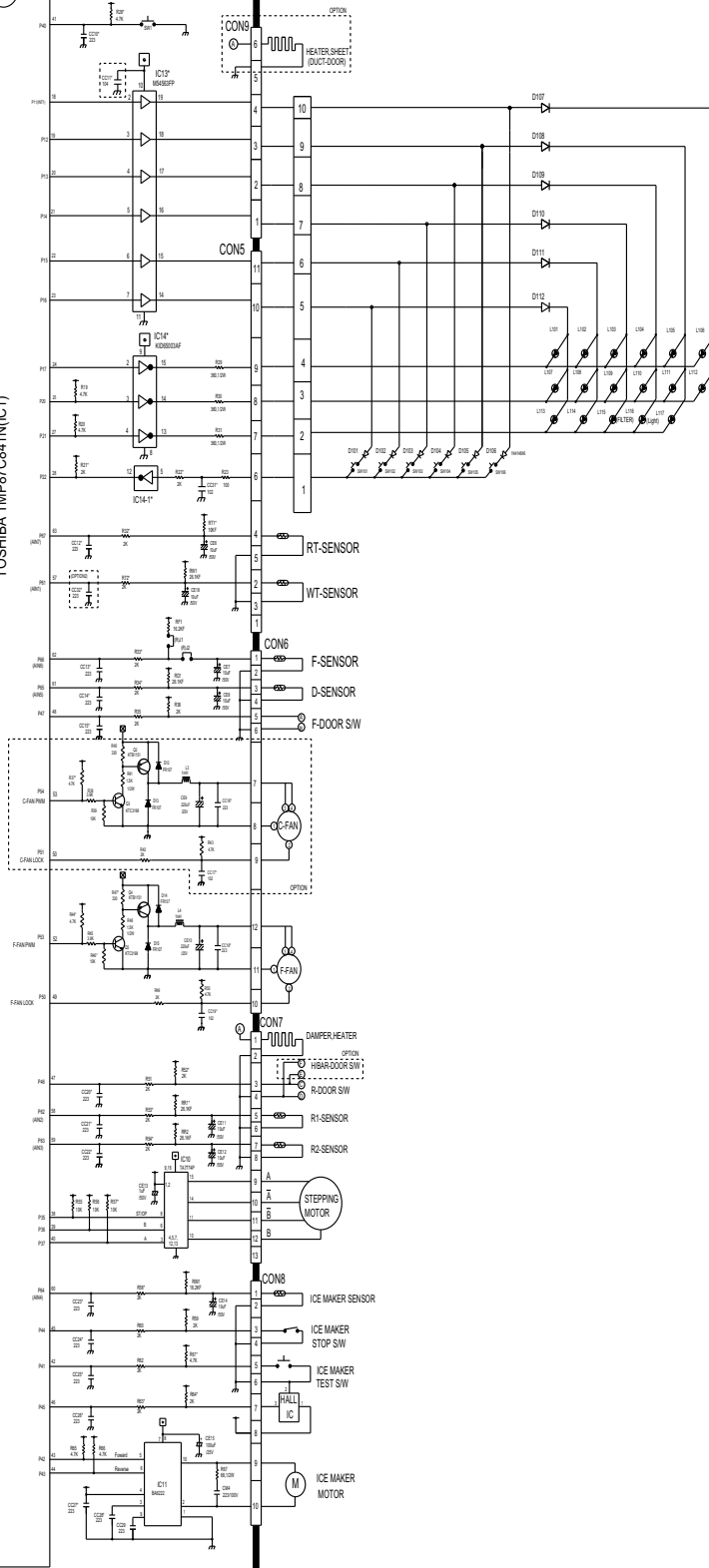

7. ICEMAKER AND DISPENSER WORKING PRICIPLES AND REPAIR

1. Working Principles

1-1. ICEMaker Working Principles

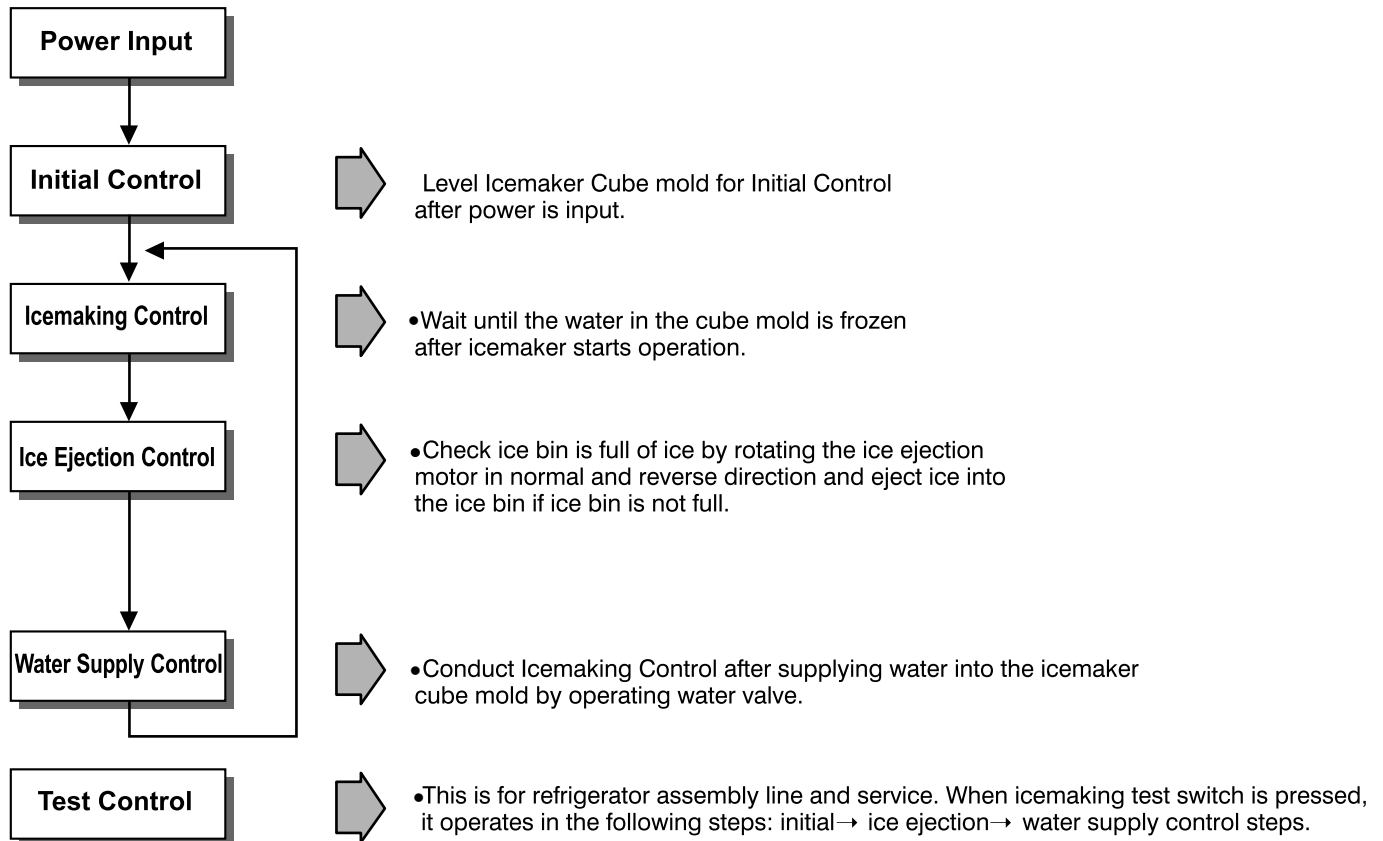

1-2. Dispenser Working Principles

1. This function is available in Model LSC27910** (Refer to appendix) where water and ice are available without opening freezer compartment door.
2. **Crushed Ice** is automatically selected when power is initially applied or reapplied after power cut.
3. When dispenser selection switch is continuously pressed, light is on in the following sequence:
Water → Cube Ice → Crushed Ice.
4. Lamp is on when dispenser button is pressed and vice versa.
5. When dispenser crushed ice rubber button is pressed, dispenser solenoid and geared motor work so that crushed ice can be dispensed if there is ice in the ice bin.
6. If there is ice in the bin, pushing the dispenser button will dispense it.
7. When dispenser water button is pressed, water valve opens and water is supplied if water valve is normally installed on the right side of the machine room.
8. Ice and water are not available when freezer door is open.

2. Function of Icemaker

2-1. Initial Control Function

1. When power is initially applied or reapplied after power cut, it detects level of icemaker cube mold after completion of MICOM initialization. The detecting lever moves up and down.
2. The level of ice maker cube mold is judged by output signal, high and low signal, of Hall IC. Make the cube mold to be horizontal by rotating ice ejection motor in normal or reverse direction so that High/Low signal can be applied to MICOM Pin No. 42.
3. If there is no change in signal one minute after the geared motor starts to operate, it stops icemaker operation and check the signal every hour. It resets initialization of icemaker when it becomes normal.
4. It judges that the initial control is completed when it judges the icemaker cube mold is horizontal.
5. Ice ejection conducts for 1 cycle regardless of ice in the ice bin when power is initially applied.

2-2. Water Supply Control Function

1. This is to supply water into the ice maker cube mold by operating water valve in the mechanical area when ice ejection control is completed and ice maker mould is even.
2. The quantity of water supplied is determined by DIP switch and time.

Water Supply Quantity Table

LSC27910** (Refer to appendix)			
No	DIP SWITCH SETTING		Water Supply Time
	S1	S2	
1	OFF	OFF	6.5SEC
2	ON	OFF	5.5SEC
3	OFF	ON	7.5SEC
4	ON	ON	8.5SEC
5			
6			
7			
8			

3. If the water supply quantity setting is changed while the power is on, the change will take effect immediately. If it is changed while the icemaker is filling the mold, the new setting will take effect the next time the icemaker cycles.
4. When water supply signal is applied to water and ice valves at the same time during water supply, water shall be supplied to water valve. If water supply signal is applied to ice valve during water supply, water shall be supplied to both water and ice valves.

2-3. Icemaking Control Function

1. Icemaking control is carried out from the completion of water supply to the completion of ice making in the cube mold. Icemaking sensor detects the temperature of cube mold and completes ice making. (ice making sensor is fixed below icemaker cube mold)
2. Icemaking control starts after completion of water supply control or initial control.
3. The icemaker determined it's cycle is completed when the Icemaking sensor reaches -8 °C (17.6°F) after 100 minutes have passes since water filled the mold.
4. It is judged that icemaking is completed when ice maker sensor temperature reaches below -12 °C after 20 minutes in condition 3.

2-4. Ice Ejection Control Function

1. This is to eject ice from ice maker cube mold after icemaking is completed.
2. If Hall IC signal is on within 3 6/10 seconds after ice ejection motor rotates in normal direction, it does not proceed ice ejection but waits. If the ice bank is full, ice ejection motor rotates in normal direction in every hour to check the condition of ice bank. If the ice bank is not full, the water supply control starts after completion of ice ejection control. If the ice bin is full, ice ejection motor rotates in reverse direction and stops under icemaking or waiting conditions.
3. If ice bin is not full, ice ejection starts. The cube mold tilts to the maximum and ice is separated from the mold and ice checking lever raises.
4. Ice ejection motor stops for 1 second if Hall IC signal changes from OFF (low) to ON (high) after 3 6/10 seconds when ice ejection motor rotates in normal direction. If there is no change in Hall IC signals within 1 minute after ice ejection motor operates, ice ejection motor stops as ice ejection motor or hall IC is out of order.
5. If ice ejection motor or Hall IC is abnormal, ice ejection motor rotates in normal direction to exercise initial operation. It resets the ice maker if ice ejection motor or Hall IC is normal.
6. The mold stops for 1 second at maximum tilted conditions.
7. The mold returns to horizontal conditions as ice ejection motor rotates in reverse direction.
8. When the mold becomes horizontal, the cycle starts to repeat:
Water Supply → Ice Making → Ice Ejection → Mold Returns to Horizontal

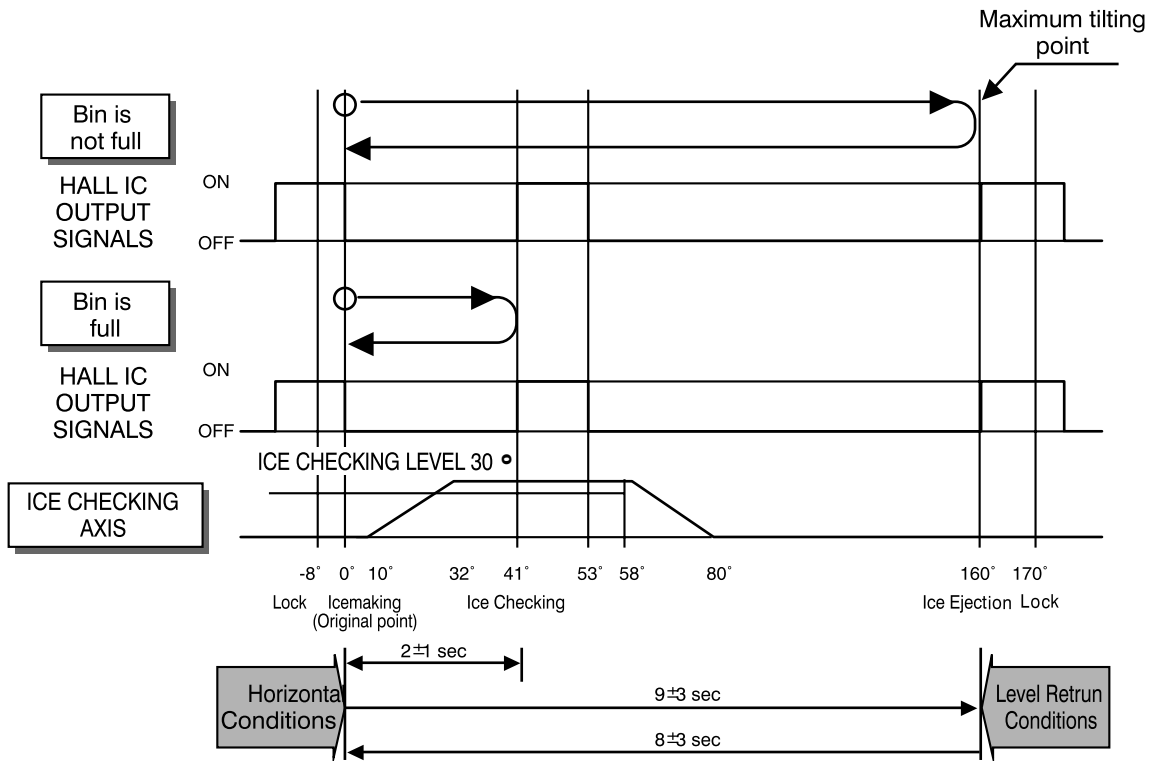

2-5 Test Function

1. It is to force the operation during operation test, service, and cleaning. The test switch is mounted under the automatic icemaker. The test function starts when the test switch is pressed for more than 1/2 second.
2. Test button does not work during ice ejection and water supply. It works when it is in the horizontal conditions. If mold is full of ice during test function operation, ice ejection control and water supply control do not work.
3. If the mold is in the horizontal (normal) position and the TEST switch is pressed for more than 1/2 second, ice ejection will begin regardless of how frozen the water might be. When the ejection is completed, the icemaker will refill the mold with water. Consequently, problems related to filling, ejecting, and returning to the horizontal position can be checked using the test switch. When this test is performed, the buzzer will sound and water will fill the mold. Check the icemaker for repair if the buzzer does not sound.
4. When water supply is completed, the cycle operates normally as follows: Icemaking → Ice ejection → Returning to horizontal conditions → Water supply
5. Remove ice from the icemaker cube mold and press test switch when icemaker cube mold is full of ice as ice ejection and water supply control do not work when cube mold is full of ice.

2-6. Other functions relating to freezer compartment door opening

1. When freezer door is open, ice dispenser stops in order to reduce noise and ice drop.
2. When freezer door is open during ice ejection and cube mold returning to horizontal condition, ice ejection and cube mold level return proceed.
3. When freezer door is open, geared motor and cube ice solenoid immediately stop and duct door solenoid stops after 5 seconds.
4. Water dispenser stops in order to protect water drop when freezer door is open.
5. Test function operates normally regardless of refrigerator compartment door opening.

3. Icemaker Troubleshooting

* **Troubleshooting:** it is possible to confirm by pressing freezer and refrigerator temperature control buttons for more than 1 second. (icemaker is normal if all LEDs are on); refer to trouble diagnosis function in MICOM function 2-8 (page 21)

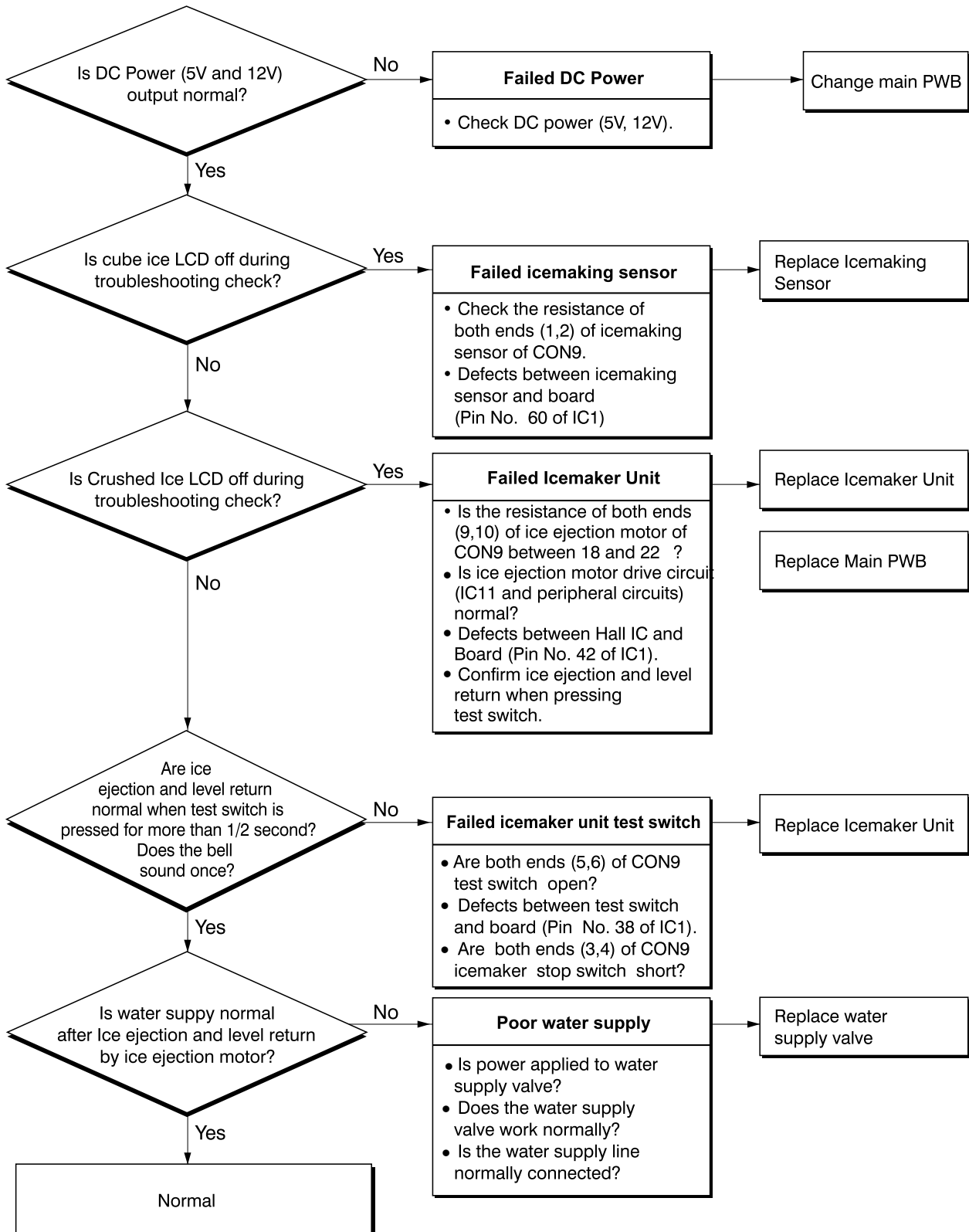

4. Icemaker Circuit

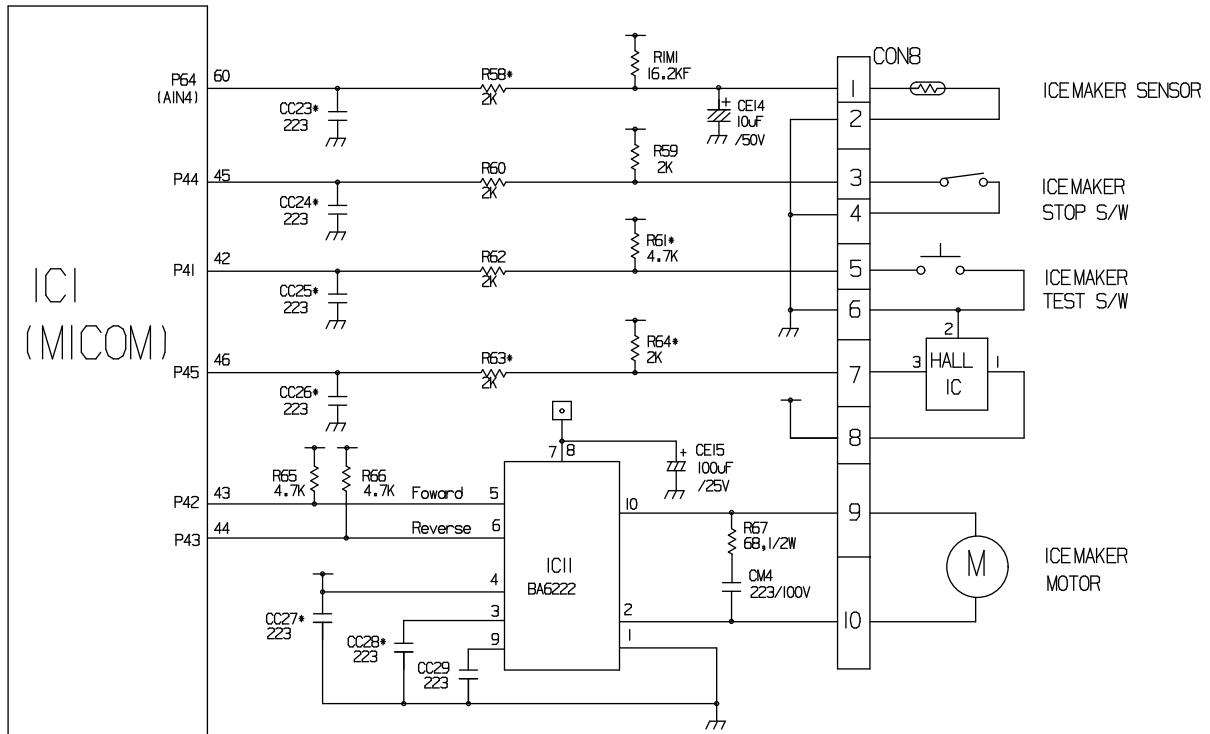

The above icemaker circuits are applied to LSC27910** and composed of icemaker unit in the freezer and icemaker driving part of main PWB. Water is supplied to the icemaker cube mold through the solenoid relay for ice valve of solenoid valve in the mechanical area by opening valve for the set time. Water supply automatically stops when water supply time is elapsed. This circuit is to realize the functions such as ice ejection of icemaker cube mold, ice full detection, leveling, Ice making temperature detection, etc. Refer to the temperature detecting circuits of Main PWB for Ice making temperature detection. Icemaker test switch input detection is the same as the door switch input detection circuit of main PWB.

1. It is to force to operate during operation test, service, and cleaning. The test switch is mounted under the automatic icemaker. The test function starts when the test switch is pressed for more than 1/2 second.
2. Test button does not work during ice ejection and water supply. It works when it is in the horizontal conditions. If cube mold is full of ice during test function operation, ice ejection control and water supply control do not work.
3. Ice ejection carries out regardless of ice formation in the ice making tray if test switch is pressed for more than 1/2 second. Water will be splashed if test switch is pressed before the water in the mold is completely frozen. Water will be supplied while the mold returns to the horizontal conditions after ice ejection. Therefore, the problems of ice ejection, leveling, and water supply can be checked by test switch. When test function performs normally, buzzer sounds and water supply shall carry out. Check it for repair if buzzer does not sound.
4. When water supply is completed, normal cycle works: Icemaking → Ice Ejection → Level Return → Water Supply.
5. If icemaker stop switch is set to ON, normal cycle operates: Icemaking → Ice Ejection → Level Return → Water Supply. If is set to OFF, ice making conducts but ice ejection, level return, and water supply do not work.

8. CIRCUIT



CIRCUIT DIAGRAM

DELUXE

- H/BAR PART (H/BAR HEATER, DOOR S/W), CAPACITOR PART, FUSE PART, PLUG TYPE, COMPRESSOR EARTH PART, ICE & WATER VALVES, PILOT VALVE, S/W PART, OPTIC HILL ZONE, WATER-TANK SENSOR ON CIRCUIT DIAGRAMS ARE SUBJECT TO CHANGE IN DIFFERENT LOCALITIES AND ACCORDANCE WITH MODEL TYPE.
 - N: NEUTRAL

PCB ASSEMBLY, MAIN

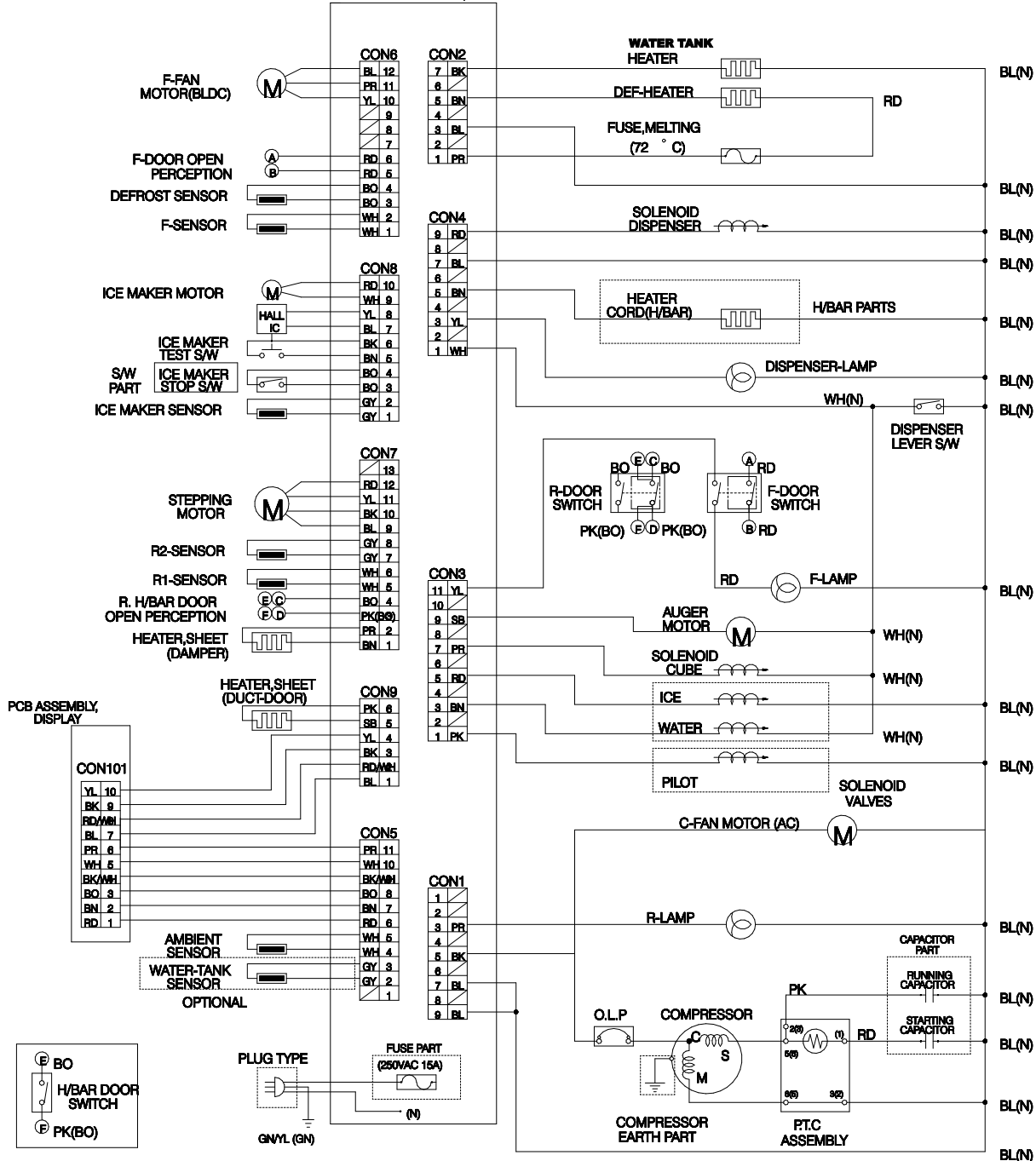

BK: BLACK	GN: GREEN	GY: GRAY	GN/YL: GREEN/YELLOW
YL: YELLOW	PK: PINK	WH: WHITE	BL/WH: BLUE/WHITE
SB: SKY BLUE	BO: BRIGHT ORANGE	BL: BLUE	BK/WH: BLACK/WHITE
BN: BROWN	PR: PURPLE	RD: RED	RD/WH: RED/WHITE

9. TROUBLE DIAGNOSIS

1. TroubleShooting

CLAIMS.	CAUSES AND CHECK POINTS.	HOW TO CHECK
<p>1. Faulty start</p>	<p>1) No power at outlet. 2) No power on cord.</p> <ul style="list-style-type: none"> - Bad connection between adapter and outlet. (faulty adapter) <ul style="list-style-type: none"> - The Inner diameter of adapter. - The distance between holes. - The distance between terminals. - The thickness of terminal. - Bad connection between plug and adapter (faulty plug). <ul style="list-style-type: none"> - The distance between pins. - Pin outer diameter. <p>3) Shorted start circuit.</p> <ul style="list-style-type: none"> - No power on power cord. <ul style="list-style-type: none"> - Disconnected copper wire. <ul style="list-style-type: none"> - Power cord is disconnected. - Faulty soldering. - Internal electrical short. - Faulty terminal contact. <ul style="list-style-type: none"> - Loose contact. - Large distance between male terminal. - Thin female terminal. - Terminal disconnected. - Bad sleeve assembly. - Disconnected. <ul style="list-style-type: none"> - Weak connection. - Short inserted cord length. - Worn out tool blade. - COMBO is off. <ul style="list-style-type: none"> - Capacity of COMBO is small. - Characteristics of COMBO is wrong. - Bad connection. - Power is disconnected. <ul style="list-style-type: none"> - Inner Ni-Cr wire blows out. - Bad internal connection. - Faulty terminal caulking (Cu wire is cut). - Bad soldering. - No electric power on compressor. - Faulty compressor. - Faulty COMBO <ul style="list-style-type: none"> - Power does not conduct. - Damage. - Characteristics of COMBO is wrong - Bad connection with compressor. <ul style="list-style-type: none"> - Too loose. - Assembly is not possible. - Bad terminal connection. <p>4) During defrost.</p> <ul style="list-style-type: none"> - Start automatic defrost. - Cycle was set at defrost when the refrigerator was produced. 	<p>* Measuring instrument: Multi tester</p> <p>Check the voltage. If the voltage is within $\pm 85\%$ of the rated voltage, it is OK.</p> <p>Check the terminal movement.</p> <p>Check both terminals of power cord. Power conducts:OK. No power conducts:NG</p> <p>Check rating of OLP OLP: 4TM437NFBYY Temp. 120°C If rating different: change it If not: OK</p> <p>Check the resistance of both terminals. Take the combo off and install it again.</p>

CLAIMS.	CAUSES AND CHECK POINTS.	HOW TO CHECK
<p>2. No cooling.</p>	<p>2) Refrigeration system is clogged.</p> <ul style="list-style-type: none"> - Moisture clogged. <ul style="list-style-type: none"> - Residual moisture in the evaporator. <ul style="list-style-type: none"> - Air Blowing. <ul style="list-style-type: none"> - Not performed. - Too short. - Impossible moisture confirmation. - Low air pressure. - Leave it in the air. <ul style="list-style-type: none"> - During rest time. - After work. - Caps are missed. - Residual moisture. <ul style="list-style-type: none"> - Not dried in the compressor. - Elapsed more than 6 months after drying - Caps are missed. - No pressure when it is open. - No electric power on thermostat. <ul style="list-style-type: none"> - Insufficient drier capacity. <ul style="list-style-type: none"> - Dry drier - Drier temperature. - Leave it in the air. <ul style="list-style-type: none"> - Check on package condition. - Good storage after finishing. - Residual moisture in pipes. <ul style="list-style-type: none"> - Caps are missed. <ul style="list-style-type: none"> - During transportation. - During work. - Air blowing. <ul style="list-style-type: none"> - Not performed. - Performed. <ul style="list-style-type: none"> - Too short time. - Low air pressure. - Less dry air. - Moisture penetration - Leave it in the air. - Moisture penetration into the refrigeration oil. - Weld joint clogged. <ul style="list-style-type: none"> - Short pipe insert. - Pipe gaps. <ul style="list-style-type: none"> - Too large. - Damaged pipes. - Too much solder. - Drier clogging. <ul style="list-style-type: none"> - The capillary tube inserted depth. - Too much. - Capillary tube melts. - Over heat. - Clogged with foreign materials. <ul style="list-style-type: none"> - Desiccant powder. - Weld oxides. - Drier angle. - Reduced cross section by cutting. - Squeezed. - Foreign material clogging. <ul style="list-style-type: none"> - Compressor cap is disconnected. - Foreign materials are in the pipe. 	<ul style="list-style-type: none"> • Heat a clogged evaporator to check it. As soon as the cracking sound starts, the evaporator will begin to freeze. • The evaporator does not cool from the beginning (no evidence of moisture attached). The evaporator is the same as before even heat is applied.

CLAIMS.	CAUSES AND CHECK POINTS.	HOW TO CHECK
<p>3. Refrigeration is weak.</p>	<p>1) Refrigerant Partly leaked. ┌ Weld joint leak. └ Parts leak.</p> <p>2) Poor defrosting capacity.</p> <p style="margin-left: 20px;">┌ Drain path (pipe) clogged. ┌ Inject adiabatics into drain └ Inject through the hole. └ Seal with drain.</p> <p style="margin-left: 20px;">┌ Foreign materials penetration. ┌ Adiabatics lump input. └ Damage by a screw or clamp. └ Other foreign materials input.</p> <p style="margin-left: 20px;">└ Cap drain is not disconnected.</p> <p style="margin-left: 20px;">┌ Defrost heater does not generate heat. ┌ Parts disconnected.</p> <p style="margin-left: 40px;">┌ Plate heater ┌ Wire is cut. └ Heating wire. └ Contact point between heating and electric wire. └ Dent by fin evaporator. └ Poor terminal contacts.</p> <p style="margin-left: 40px;">┌ Cord heater ┌ Wire is cut. └ Lead wire. └ Heating wire. └ Contact point between heating and electric wire. └ Heating wire is corroded └ Water penetration. └ Bad terminal connection.</p>	<ul style="list-style-type: none"> • Check visually. • Check terminal Conduction: OK. No conduction: NG. If wire is not cut, refer to resistance. P=Power V=Voltage R=Resistance $P = \frac{V^2}{R}$ $R = \frac{V^2}{P}$

CLAIMS.	CAUSES AND CHECK POINTS.	HOW TO CHECK
<p>3. Refrigeration is weak.</p>	<ul style="list-style-type: none"> Residual frost. <ul style="list-style-type: none"> Weak heat from heater. <ul style="list-style-type: none"> Sheath Heater - rated. Heater plate <ul style="list-style-type: none"> No contact to drain. Loosened stopper cord. Heater cord-L <ul style="list-style-type: none"> Not touching the evaporator pipe. Location of assembly (top and middle). Too short defrosting time. <ul style="list-style-type: none"> Defrost Sensor <ul style="list-style-type: none"> - Faulty characteristics. Seat-D (missing, location. thickness). Structural fault. <ul style="list-style-type: none"> Gasket gap. Air inflow through the fan motor. Bad insulation of case door. No automatic defrosting. Defrost does not return. <p>3) Cooling air leak.</p> <ul style="list-style-type: none"> Bad gasket adhesion <ul style="list-style-type: none"> Gap. Bad attachment. Contraction. Door sag. <ul style="list-style-type: none"> Bad adhesion. Weak binding force at hinge. <p>4) No cooling air circulation.</p> <ul style="list-style-type: none"> Faulty fan motor. <ul style="list-style-type: none"> Fan motor. <ul style="list-style-type: none"> Self locked. Wire is cut. Bad terminal contact. Door switch. <ul style="list-style-type: none"> Faults. <ul style="list-style-type: none"> Contact distance. Button pressure. Melted contact. Contact. Refrigerator and freezer switch reversed. Button is not pressed. <ul style="list-style-type: none"> Poor door attachment. Door liner (dimension). Contraction inner liner. Misalignment. Bad terminal connection. Adiabatics liquid leak. 	<ul style="list-style-type: none"> • Check the fan motor conduction: OK. No conduction: NG.

CLAIMS.	CAUSES AND CHECK POINTS.	HOW TO CHECK
<p>3. Refrigeration is weak.</p>	<p>4) No cooling air circulation.</p> <ul style="list-style-type: none"> Faulty fan motor. — Fan is constrained. <ul style="list-style-type: none"> Fan shroud contact. - Clearance. Damping evaporator contact. Accumulated residual frost. Small cooling air discharge. — Insufficient motor RPM <ul style="list-style-type: none"> Fan overload. - Fan misuse. Bad low temperature RPM characteristics. Rated power misuse. Low voltage. — Faulty fan. <ul style="list-style-type: none"> Fan misuse. Bad shape. Loose connection. - Not tightly connected. Insert depth. — Shroud. — Bent. — Ice and foreign materials on rotating parts. <p>5) Compressor capacity. <ul style="list-style-type: none"> Rating misuse. Small capacity. Low voltage. </p> <p>6) Refrigerant too much or too little. <ul style="list-style-type: none"> Malfunction of charging cylinder. Wrong setting of refrigerant. Insufficient compressor. - Faulty compressor. </p> <p>7) Continuous operation <ul style="list-style-type: none"> - No contact of temperature controller. - Foreign materials. </p> <p>8) Damper opens continuously. <ul style="list-style-type: none"> Foreign materials jammed. <ul style="list-style-type: none"> Adiabatics liquid dump. The EPS (styrofoam) drip tray has sediment in it. A screw or other foreign material has fallen into the drip tray or damper. Failed sensor. - Position of sensor. Characteristics of damper. <ul style="list-style-type: none"> Bad characteristics of its own temperatue. Parts misuse. Charge of temperature - Impact. characteristics. </p> <p>9) Food storing place. - Near the outlet of cooling air.</p>	<ul style="list-style-type: none"> • Check visually after disassembly. • Check visually after disassembly.

CLAIMS.	CAUSES AND CHECK POINTS.	HOW TO CHECK
<p>4. Warm refrigerator compartment temperature.</p>	<p>1) Colgged cooling path.</p> <ul style="list-style-type: none"> └ Adiabatics liquid leak. └ Foreign materials. — Adiabatics dump liquid. <p>2) Food storate.</p> <ul style="list-style-type: none"> └ Store hot food. └ Store too much at once. └ Door open. └ Packages block air flow. 	
<p>5. No automatic operation. (faulty contacts)</p>	<p>1) Faulty temperature sensor in freezer or refrigerator compartment.</p> <ul style="list-style-type: none"> └ Faulty contact. └ Faulty temperature characteristics. <p>2) Refrigeration load is too much.</p> <ul style="list-style-type: none"> └ Food. <ul style="list-style-type: none"> └ Too much food. └ Hot food. └ Frequent opening and closing. └ Cool air leak. └ Poor door close. — Partly opens. <p>3) Poor insulation.</p> <p>4) Bad radiation.</p> <ul style="list-style-type: none"> └ High ambient temperature. └ Space is secluded. <p>5) Refrigerant leak.</p> <p>6) Inadequate of refrigerant.</p> <p>7) Weak compressor discharging power.</p> <ul style="list-style-type: none"> └ Different rating. └ Small capacity. <p>8) Fan does not work.</p> <p>9) Button is set at strong .</p>	<ul style="list-style-type: none"> • Inspect parts measurements and check visually.
<p>6. Condensation and ice formation.</p>	<p>1) Ice in freeezer compartment.</p> <ul style="list-style-type: none"> └ External air inflow.— Bushing installed incorrectly. └ Door opens but not closes. <ul style="list-style-type: none"> └ Weak door closing power. └ Stopper malfunction. └ Door sag. └ Food hinders door closing. └ Gap around gasket. — Contraction, distortion, loose, door twisted, corner not fully inserted. └ Food vapor. — Storing hot food. — Unsealed food. <p>2) Condensation in the refrigerator compartment.</p> <ul style="list-style-type: none"> └ Door opens but not closes. <ul style="list-style-type: none"> └ Insufficient closing. └ Door sag. └ Food hinders door closing. └ Gasket gap. <p>3) Condensation on liner foam.</p> <ul style="list-style-type: none"> └ Cool air leak and transmitted. <ul style="list-style-type: none"> └ Not fully filled. <ul style="list-style-type: none"> └ Top table part. └ Out plate Ref/Lower part. └ Flange gap. — Not sealed. └ Gasket gap. 	

CLAIMS.	CAUSES AND CHECK POINTS.	HOW TO CHECK
<p>6. Condensation and ice formation.</p>	<p>4) Condensation on door.</p> <ul style="list-style-type: none"> Condensation on the duct door. - Duct door heater is cut. Condensation on the dispense recess. <ul style="list-style-type: none"> Recess Heater is cut. Duct door is open. / Foreign material clogging. Condensation on the door surface. <ul style="list-style-type: none"> Not fully filled. <ul style="list-style-type: none"> Surface. } Liquid shortage Corner. } Liquid leak Adiabatics liquid contraction. Condensation on the gasket surface. <ul style="list-style-type: none"> Bad wing adhesion. <ul style="list-style-type: none"> Wing sag(lower part). Door liner shape mismatch. Corner. <ul style="list-style-type: none"> Too much notch. Broken. Home Bar heater is cut. <p>5) Water on the floor.</p> <ul style="list-style-type: none"> Condensation in the refrigerator compartment. Defrosted water overflows. — Clogged discharging hose. Discharging hose — Evaporation tray located at wrong place. location. Tray drip. <ul style="list-style-type: none"> Damaged. Breaks, holes. Small Capacity. Position of drain. 	
<p>7. Sounds</p>	<p>1) Compressor compartment operating sounds.</p> <ul style="list-style-type: none"> Compressor sound inserted. <ul style="list-style-type: none"> Sound from machine itself. Sound from vibration. <ul style="list-style-type: none"> Restrainer. Bushing seat. <ul style="list-style-type: none"> Too hard. Distorted. Aged. Burnt. Stopper. — Bad Stopper assembly. <ul style="list-style-type: none"> Not fit (inner diameter of stopper). Tilted. Not Compressor base not connected. Bad welding compressor stand(fallen). Foreign materials in the compressor compartment. COMBO sound — Chattering sound. Capacitor noise. — Insulation paper vibration. Pipe sound. <ul style="list-style-type: none"> Pipe contacts each other. - Narrow interval. No vibration damper. <ul style="list-style-type: none"> Damping Bushing-Q. Damping Bushing-S. Capillary tube unattached. 	

CLAIMS.	CAUSES AND CHECK POINTS.	HOW TO CHECK
7. Sounds	<p>1) Compressor compartment operating sounds.</p> <ul style="list-style-type: none"> Transformer sound. <ul style="list-style-type: none"> Its own fault. - Core gap. Bad connection. - Correct screw connection. Drip tray vibration sound. <ul style="list-style-type: none"> Bad assembly. Distortion. Foreign materials inside. Back cover machine sound. <ul style="list-style-type: none"> Bad connection. Partly damaged. Condenser drain sound. <ul style="list-style-type: none"> Not connected. Bad pipe caulking. <p>2) Freezer compartment sounds.</p> <ul style="list-style-type: none"> Fan motor sound. <ul style="list-style-type: none"> Normal operating sound. Vibration sound. <ul style="list-style-type: none"> Aged rubber seat. Bad torque for assembling motor bracket. Sounds from fan contact. <ul style="list-style-type: none"> Fan guide contact. Shroud burr contact. Damping evaporator contact. Residual frost contact. <ul style="list-style-type: none"> Damaged heater cord. Narrow evaporator interval. Unbalance fan sounds. <ul style="list-style-type: none"> Unbalance. <ul style="list-style-type: none"> Surface machining conditions. Fan distortion. Misshappen. Burr. Ice on the fan. - Air intake (opposite to motor bushing assembly) Motor shaft contact sounds. <ul style="list-style-type: none"> Supporter disorted. Tilted during motor assembly. Resonance. Evaporator noise. <ul style="list-style-type: none"> Evaporator pipe contact. - No damping evaporator. Sound from refrigerant. - Stainless steel pipe shape in accumulator. Sound from fin evaporator and pipe during expansion and contraction. <p>3) Bowls and bottles make contact on top shelf.</p> <p>4) Refrigerator roof contact.</p> <p>5) Refrigerator side contact.</p> <p>6) Insufficient lubricants on door hinge.</p>	

CLAIMS.	CAUSES AND CHECK POINTS.	HOW TO CHECK
<p>8. Faulty lamp (freezer and refrigerator compartment).</p>	<p>1) Lamp problem. — Filament blows out. — Glass is broken.</p> <p>2) Bad lamp assembly. — Not inserted. — Loosened by vibration.</p> <p>3) Bad lamp socket.</p> <ul style="list-style-type: none"> — Disconnection. — Bad soldering. — Bad rivet contact. — Short. — Water penetration. — Low water level in tray. — Bad elasticity of contact. — Bad contact (corrosion). <p>4) Door switch. — Defective. — Refrigerator and freezer switches are reversed. — Travel distance. — Bad connection. — Bad terminal contact. — Adiabatics liquid leak..</p>	
<p>9. Faulty internal voltage (short).</p>	<p>1) Lead wire is damaged.</p> <ul style="list-style-type: none"> — Wire damage when assembling Bracket Cover. — Outlet burr in the bottom plate. — Pressed by cord heater. lead wire, evaporator pipe. <p>2) Exposed terminal.</p> <ul style="list-style-type: none"> — Compressor Compartment terminal. - Touching other components. — Freezer compartment terminal. - Touching evaporator pipe. <p>3) Faulty parts.</p> <ul style="list-style-type: none"> — Transformer. — Coil contacts cover. — Welded terminal parts contact cover. — Compressor. — Bad coil insulation. — Plate heater. — Melting fuse. — Sealing is broken. — Moisture penetration. — Cord heater. — Pipe damaged. — Moisture penetration. — Bad sealing. — Sheath heater. 	<ul style="list-style-type: none"> • Connect conduction and non-conduction parts and check with tester. Conduction: NG. Resistance° : OK.

CLAIMS.	CAUSES AND CHECK POINTS.	HOW TO CHECK
<p>10. Structure, appearance, and others.</p>	<p>1) Door foam.</p> <ul style="list-style-type: none"> Sag. <ul style="list-style-type: none"> Hinge loose <ul style="list-style-type: none"> Bolt is loosened during transportation. Not tightly fastened. Screw worn out . Weak gasket adhesion. <ul style="list-style-type: none"> Adhesion surface. Fixed tape. <ul style="list-style-type: none"> Not well fixed. Noise during operation. <ul style="list-style-type: none"> Hinge interference. <ul style="list-style-type: none"> Bigger door foam. Hinge-Pin tilted-Poor flatness. No washer. No grease. Malfunction. <ul style="list-style-type: none"> Not closed Refrigerator compartment is opened when freezer compartment is closed (faulty stopper). <ul style="list-style-type: none"> Interference between door liner and inner liner. <ul style="list-style-type: none"> Stopper worn out. Bad freezer compartment door assembly. No stopper. <p>2) Odor.</p> <ul style="list-style-type: none"> Temperature of refrigerator compartment. <ul style="list-style-type: none"> High. <ul style="list-style-type: none"> Faulty damper control. Button is set atweak. Door is open (interference by food). Deodorizer. <ul style="list-style-type: none"> No deodorizer. Poor capacity. Food Storage. <ul style="list-style-type: none"> Seal condition. Storage of fragrant foods. Long term storage. Others. <ul style="list-style-type: none"> Odors from cleaners or items which shroud not be stored in a refrigerator. 	

2. Faults

2-1. Power

Problems	Causes	Checks	Measures	Remarks
No power on outlet.	<ul style="list-style-type: none"> - Power cord cut. - Faulty connector insertion. - Faulty connection between plug and adapter. 	<ul style="list-style-type: none"> - Check the voltage with tester. - Check visually. - Check visually. 	<ul style="list-style-type: none"> - Replace the components. - Reconnect the connecting parts. - Reconnect the connecting parts. 	
Fuse blows out.	<ul style="list-style-type: none"> - Short circuit by wrong connection. - Low voltage products are connected to high voltage. - Short circuit by insects. - Electricity leakage. - High voltage. - Short circuit of components (tracking due to moisture and dust penetration). 	<ul style="list-style-type: none"> - Check the fuse with tester or visually. - Check the input volt are with tester (between power cord and products). - Check the resistance of power cord with tester (if it is 0Ω, it is shorted). 	<ul style="list-style-type: none"> - Find and remove the cause of problem (ex. short, high voltage, low voltage). - Replace with rated fuse. 	<ul style="list-style-type: none"> - Replace with rated fuse after confirming its specification. - If fuse blows out frequently, confirm the cause and prevent.

2-2. Compressor

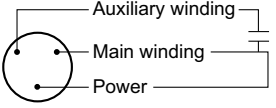
Problems	Causes	Checks	Measures	Remarks
Compressor does not operate.	- Faulty Combo.	<ul style="list-style-type: none"> - Check the resistance. Value: ∞ is defective.	<ul style="list-style-type: none"> - If resistance is infinite, replace it with new one. - If it is not infinite, it is normal. - Check other parts. 	
	- Compressor is frozen.	<ul style="list-style-type: none"> - If compressor assembly parts are normal (capacitor, PTC, OLP), apply power directly to the compressor to force operation.  <p>OLP It starts as soon as it is contacted.</p>	<ul style="list-style-type: none"> - During forced operation: - Operates: Check other parts. - Not operate: Replace the frozen compressor with new one, weld, evacuate, and recharge refrigerant. <ul style="list-style-type: none"> • Refer to weld repair procedures. 	

2-3. Temperature

Problems	Causes	Checks	Measures	Remarks
High temperature in the freezer compartment.	Poor cool air circulation due to faulty fan motor.	<ul style="list-style-type: none"> - Lock — Check resistance with a tester. <li style="padding-left: 20px;">0Ω: short. <li style="padding-left: 20px;">∞Ω: cut. - Rotate rotor manually and check rotation. - Wire is cut. - Bad terminal contact: Check terminal visually. - Fan constraint. - Fan shroud contact: Confirm visually. <li style="padding-left: 20px;">- Fan icing: Confirm visually. 	<ul style="list-style-type: none"> - Replace fan motor. - Reconnect and reinsert. - Maintain clearance and remove ice (Repair and/or replace shroud if fan is constrained by shroud deformation). 	
	Faulty fan motor due to faulty door switch operation.	<ul style="list-style-type: none"> - Iced button (faulty) operation: Press button to check - Faulty button pressure and contact: Press button to check operation. - Door cannot press door switch button: Check visually. 	<ul style="list-style-type: none"> - Confirm icing causes and repair. - Replace door switch. - Door sag: fix door. - Door liner bent: replace door or attach sheets. 	
	Bad radiation conditions in compressor compartment.	<ul style="list-style-type: none"> - Check the clearance between the refrigerator and wall (50 mm in minimum). - Check dust on the grill in compressor compartment. - Check dust on the condenser coils. 	<ul style="list-style-type: none"> - Keep clearance between refrigerator and walls (minimum 50mm). - Remove dust and contaminants from grill for easy heat radiation. - Remove the dust with vacuum cleaner from the coils condenser while the refrigerator is off. 	<ul style="list-style-type: none"> - The fan may be broken if cleaning performs while the refrigerator is on.

2-4. Cooling

Problems	Causes	Checks	Measures	Remarks
High temperature in the freezer compartment.	Refrigerant leak.	<p><u>Check sequence</u></p> <ol style="list-style-type: none"> 1. Check the welded parts of the drier inlet and outlet and drier auxiliary in the compressor compartment (high pressure side). 2. Check the end of compressor sealing pipe (low pressure side). 3. Check silver soldered parts. (Cu + Fe / Fe + Fe). 4. Check bending area of wire condenser pipe in compressor compartment (cracks can happen during bending). 5. Check other parts (compressor compartment and evaporators in freezer compartment). 	Weld the leaking part, recharge the refrigerant.	Drier must be replaced.
	Shortage of refrigerant.	<p>Check frost formation on the surface of evaporator in the freezer compartment.</p> <ul style="list-style-type: none"> - If the frost forms evenly on the surface, it is OK. - If it does not, it is not good. 	<ul style="list-style-type: none"> - Find out the leaking area, repair, evacuate, and recharge the refrigerant. - No leaking, remove the remaining refrigerant, and recharge new refrigerant. 	Drier must be replaced.

Problems	Causes	Checks	Measures	Remarks
High temperature in the freezer compartment.	Cycle pipe is clogged.	<p>Check sequence.</p> <ol style="list-style-type: none"> 1. Check temperature of condenser manually. If it is warm, OK. If it is not, compressor discharging joints might be clogged. 2. Manually check whether hot line pipe is warm. If it is warm, OK. If it is not, condenser outlet weld joints might be clogged. 	<ul style="list-style-type: none"> - Heat up compressor discharging weld joints with touch, disconnect the pipes, and check the clogging. Remove the causes of clogging, weld, evacuate, and recharge the refrigerant. - If it's warm, OK. If it's not, condenser discharging line weld joints might be clogged. Disconnect with torch, remove the causes, evacuate, and recharge seal refrigerant. 	Drier must be replaced.
	Leak at loop pipe weld joint (discharge) in compressor.	<p>Check sequence.</p> <ol style="list-style-type: none"> 1. Manually check whether condenser is warm, It is not warm and the frost forms partly on the evaporator in the freezer compartment. 	Replace the compressor, weld, evacuate, and recharge refrigerant.	Drier must be replaced.
	Faulty cooling fan in the compressor compartment.	<p>Check sequence.</p> <ol style="list-style-type: none"> 1. Check cooling fan operation. 2. Check that cooling fan is disconnected from the motor. 	<ul style="list-style-type: none"> - Replace if motor does not operate. - If fan is disconnected, check fan damage and reassemble it. Refer to fan motor disassembly and assembly sequence. 	

2-5. Defrosting failure

Problems	Causes	Checks	Measures	Remarks
No defrosting.	<p>Heater does not generate heat as the heating wire is cut or the circuit is shorted.</p> <ol style="list-style-type: none"> 1) Heating wire is damaged when inserting into the evaporator. 2) Lead wire of heater is cut. 3) Heating wire at lead wire contacts is cut. 	<ol style="list-style-type: none"> 1. Check the resistance of heater. 0Ω: Short. ∞Ω: Cut. Tens to thousands Ω: OK. 2. Check the resistance between housing terminal and heater surface. 0Ω: Short. ∞Ω: Cut. Tens to thousands Ω: Short. 	<p>Heating wire is short and wire is cut.</p> <ul style="list-style-type: none"> • Parts replacement: Refer to parts explanations. 	<p>Seal the lead wire with insulation tape and heat shrink tube if the cut lead wire is accessible to repair.</p>
	<p>Suction tube and discharge orifice:</p> <ol style="list-style-type: none"> 1. Impurities. 2. Ice. 	<ol style="list-style-type: none"> 1. Confirm foreign materials. In case of ice, insert the copper line through the hole to check. 2. Put hot water into the drain (check drains outside). 	<ol style="list-style-type: none"> 1) Push out impurities by inserting copper wire. (Turn off more than 3 hours and pour in hot water if frost is severe.) 2) Put in hot water to melt down frost. 3) Check the water outlet. 4) Push the heater plate to suction duct manually and assemble the disconnected parts. 	
	<p>Gap between Suction duct and Heater plate (Ice in the gap).</p>	<ol style="list-style-type: none"> 1. Confirm in the Suction duct. 	<ol style="list-style-type: none"> 1) Turn off the power, confirm impurities and ice in the gap, and supply hot water until the ice in the gap melts down. 2) Push the Heater plate to drain bottom with hand and assemble the disconnected parts. 	
Wrong heater rating (or wrong assembly).		<ol style="list-style-type: none"> 1. Check heater label. 2. Confirm the capacity after substituting the resistance value into the formula. $P = \frac{V^2}{R}$ <p>(V: Rated voltage of user country) (R: Resistance of heater[Ω])</p> <p>Compare P and level capacity. Tolerance: ±7%</p>	<p>Faults:replace.</p> <p>- How to replace : Refer to main parts.</p>	

Problems	Causes	Checks	Measures	Remarks
No defrosting	Melting fuse blows. 1) Lead wire is cut. 2) Bad soldering.	- Check melting fuse with tester. - If 0Ω : OK. If $\infty\Omega$: wire is cut.	Faulty parts: parts replacement. - Check wire color when measuring resistance with a tester.	
	Ice in the Suction duct. 1) Icing by foreign materials in the duct. 2) Icing by cool air inflow through the gap of heater plate. 3) Icing by the gap of heater plate.	1. Check the inner duct with mirror. 2. Check by inserting soft copper wire into the duct (soft and thin copper not to impair heating wire).	1) Turn power off. 2) Raise the front side (door side), support the front side legs, and let the ice melt naturally. (If power is on, melt the frost by forced defrosting.) 3) Reassemble the heater plate.	
	Bad cool air inflow and discharge, and bad defrosting due to faulty contact and insertion (bad connector insertion into housing of heater, melting, fuse, and motor fan).	1. Turn on power, open or close the door, check that motor fan operates (If it operates, motor fan is OK). 2. Disconnect parts in the refrigerator compartment, check the connection around the housing visually, defrost, and confirm heat generation on the heater. Do not put hands on the sheath heater. 3. Check the parts which have faults described in 1 & 2 (mechanical model: disconnect thermostat from the assembly).	1) Check the faulty connector of housing and reassemble wrongly assembled parts. 2) If the parts are damaged, remove the parts and replace it with a new one.	

2-6. Icing

Problems	Causes	Checks	Measures	Remarks
Icing in the refrigerator compartment. - Damper icing. - Pipe icing. - Discharging pipe icing.	1) Bad circulation of cool air. - Clogged intake port in the refrigerator compartment. - Sealing is not good. - Too much food is stored and clogs the discharge port. - Bad defrosting.	- Check the food is stored properly (check discharge and intake port are clogged). - Check icing on the surface of baffle and cool air path (pipe) after disassembling the container box. - Check icing at intake ports of freezer and refrigerator compartment.	- Be acquainted with how to use. - Sealing on connecting parts. - Check the damper and replace it if it has defects. - Check defrost. (After forced defrosting, check ice in the evaporator and pipes.)	- Check the defrost related parts if problem is caused by faulty defrosting.
	2) Faulty door or refrigerator compartment. - Faulty gasket. - Faulty assembly.	- Check gasket attached conditions. - Check door assembly conditions.	- Correct the gasket attachment conditions and replace it. - Door assembly and replacement.	- Replacement should be done when it cannot be repaired.
	3) Overcooling in the refrigerator compartment. - Faulty damper in the refrigerator compartment. - Faulty MICOM (faulty sensor)	- Check refrigerator compartment is overcooled (when button pressed on weak). - Check parts are faulty.	- Replace faulty parts.	
	4) Bad defrosting - Heater wire is cut. - Defective defrost sensor. - Defrosting cycle.	- Check frost on the evaporator after disassembling shroud and fan grille. - Check ice on intake port of freezer and refrigerator compartment.	- Check parts related to defrosting. - Check defrosting. (Check ice on the evaporator and pipe.)	- Moisture does not freeze on the evaporator but can be sucked into the refrigerator, where it condenses and freezes. This interferes with cold air circulation and sublimation of the ice.
	5) Customers are not familiar with this machine. - Door opens. - High temperature, high moisture, and high load.	- Check food interferes with door closing. - Check ice on the ceilings.	- Be acquainted with how to use.	

Problem	Cause	Check	Measure	Remarks
Ice in the freezer compartment. - Surface of fan grille. - Wall of freezer compartment. - Cool air discharging port. - Basket(rack) area.	1) Bad cooling air circulation. - Intake port is clogged in the freezer compartment. - Discharging port is Clogged. - Too much food is stored. - Bad defrosting.	- Check food storage conditions visually.(Check clogging at intake and discharging port of cooling air.) - Check food occupation ratio in volume (Less than 75%). - Check frost on the evaporator after dissembling shroud and fan grille. - Check icing at intake port of refrigerator compartment.	- Be acquainted with how to use. - Check defrost (Check ice on the evaporator and pipes after forced defrosting).	- Check the parts related to defrosting if the problem is caused by the faulty defrosting.
- Food surface. - Icing in the shute.	2) Bad freezer compartment door - Faulty gasket - Faulty assembly	- Check gasket attachment conditions. - Check door assembly conditions.	- Correct the gasket attachment conditions and replace it. - Door assembly and replacement.	- Replace when it can not be repaired.
	3) Over freezing in the freezer compartment. - Faulty MICOM.	- Refrigerator operates pull down. (Check if it is operated intermittently) - The Temperature of freezer compartment is satisfactory, but over freezing happens in the refrigerator compartment even though the notch is set at weak .	-Replace defective parts.	
	4) Bad defrosting. - Heater wire is cut. - Faulty defrost sensor. - Defrosting cycle	- Check frost on the evaporator after dissembling shroud and grille. - Check ice on the intake port in the refrigerator compartment.	- Check parts related to defrosting. - Check defrosting. Check ice on the evaporator and pipes after forced defrosting.	
	5) User is not familiar with how to use. - Door opens. - High moisture food water is stored.	- Check food holds door open. - Check ice on the ice tray.	- Be acquainted with how to use.	

2-7. Sound

Problems	Causes	Checks	Measures	Remarks
Hiss sound	1. Loud sound of compressor operation.	1.1 Check the level of the refrigerator. 1.2 Check the bushing seat conditions (sagging and aging).	1) Maintain horizontal level. 2) Replace bushing and seat if they are sagged and aged. 3) Touch the piping at various place along its route. Install a damper at the point where your touch reduces the noise. 4) Avoid pipe interference. 5) Replace defective fan and fan motor. 6) Adjust fan to be in the center of the fan guide. 7) Leave a clearance between interfering parts and seal gaps in the structures. 8) Reassemble the parts which make sound. 9) Leave a clearance if evaporator pipes and suction pipe touch freezer shroud.	
	2. Pipes resonate sound which is connected to the compressor.	2.1 Check the level of pipes connected to the compressor and their interference. 2.2 Check bushing inserting conditions in pipes. 2.3 Touch pipes with hands or screw-driver (check the change of sound).		
	3. Fan operation sound in the freezer compartment.	3.1 Check fan insertion depth and blade damage. 3.2 Check the interference with structures. 3.3 Check fan motor. 3.4 Check fan motor bushing insertion and aging conditions.		
	4. Fan operation sound in the compressor compartment.	4.1 Same as fan confirmation in the refrigerator. 4.2 Check drip tray leg insertion. 4.3 Check the screw fastening conditions at condenser and drip tray.		

Problems	Causes	Checks	Measures	Remarks
<p>Vibration sound. Clack.</p>	<ol style="list-style-type: none"> 1. Vibration of shelves and foods in the refrigerator. 2. Pipes interference and capillary tube touching in the compressor compartment. 3. Compressor stopper vibration. 4. Moving wheel vibration. 5. Other structure and parts vibration. 	<ol style="list-style-type: none"> 1-1. Remove and replace the shelves in the refrigerator 1-2. Check light food and container on the shelves. 2-1. Touch pipes in the compressor compartment with hands. 2-2. Check capillary tube touches cover back. 3-1. Check compressor stopper Vibration. 4-1. Check vibration of front and rear moving wheels. 5-1. Touch other structures and parts. 	<ol style="list-style-type: none"> 1) Reassemble the vibrating parts and insert foam or cushion where vibration is severe. 2) Leave a clearance where parts interfere with each other. 3) Reduce vibration with bushing and restrainer if it is severe. (especially compressor and pipe). 4) Replace compressor stopper if it vibrates severely. 	
<p>Irregular sound. Click .</p>	<ol style="list-style-type: none"> 1. It is caused by heat expansion and contraction of evaporator, shelves, and pipes in the refrigerator. 	<ol style="list-style-type: none"> 1-1 Check time and place of sound sources. 	<ol style="list-style-type: none"> 1) Explain the principles of refrigeration and that the temperature difference between operation and defrosting can make sounds. 2) If evaporator pipe contacts with other structures, leave a clearance between them (freezer shroud or inner case). 	

Problems	Causes	Checks	Measures	Remarks
Sound Popping (almost the same as animals crying sound).	It happens when refrigerant expands at the end of capillary tube.	<ul style="list-style-type: none"> - Check the sound of refrigerant at the initial installation. - Check the sound when the refrigerator starts operation after forced defrosting. - Check the restrainer attachment conditions on the evaporator and capillary tube weld joints. 	<ul style="list-style-type: none"> - Check the restrainer attached on the evaporator and capillary tube weld joints and attach another restrainer. - If it is continuous and severe, insert capillary tube again (depth 15±3mm) - Fasten the capillary tube to suction pipes or detach in the compressor compartment. - Explain the principles of freezing cycles. 	
Water boiling or flowing sound.	It happens when refrigerant passes orifice in accumulator internal pipes by the pressure difference between condenser and evaporator.	<ul style="list-style-type: none"> - Check the sound when compressor is turned on. - Check the sound when compressor is turned off. 	<ul style="list-style-type: none"> - Explain the principles of freezing cycles and refrigerant flowing phenomenon by internal pressure difference. - If sound is severe, wrap the accumulator with foam and restrainer. 	
Sound of whistle when door closes.	When door closes, the internal pressure of the refrigerator decreases sharply below atmosphere and sucks air into the refrigerator, making the whistle sound.	<ul style="list-style-type: none"> - Check the sound by opening and closing the refrigerator or freezer doors. 	<ul style="list-style-type: none"> - Broaden the cap of discharge hose for defrosting in the compressor compartment. - Seal the gap with sealant between out and inner cases of hinge in door. 	

2-8. Odor

Problems	Causes	Checks	Measures	Remarks
Food Odor.	Food (garlic, kimchi, etc)	<ul style="list-style-type: none"> - Check the food is not wrapped. - Check the shelves or inner wall are stained with food juice. - Be sure food is securely covered with plastic wrap. - Check food cleanliness. 	<ul style="list-style-type: none"> - Dry the deodorizer in a sunny place with adequate ventilation. - Store the food in the closed container instead of vinyl wraps. - Clean the refrigerator and set button at strong. 	
Plastic Odor.	Odors of mixed food and plastic odors.	<ul style="list-style-type: none"> - Check wet food is wrapped with plastic bowl and bag. - It happens in the new refrigerator. 	<ul style="list-style-type: none"> - Clean the refrigerator. - Persuade customers not to use plastic bag or wraps with wet food or odorous foods. 	
Odor from the deodorizer.	Odor from the old deodorizer.	<ul style="list-style-type: none"> - Check the deodorizer odors. 	<ul style="list-style-type: none"> - Dry the deodorizer with dryer and then in the shiny and windy place. - Remove and replace the deodorants. 	*Deodorizer : option

2-9. Micom

Problems	Symptom	Causes		Checks	Measures	Remarks			
Bad PCB electric power.	All display LCD are off.	Bad connection between Main PCB and display circuit.	Bad connector connection from main PCB to display PCB.	Visual check on connector connection.	Reconnect connector.				
		Defective PCB transformer.	PCB transformer winding is cut.	Check resistance of PCB transformer input and output terminals with a tester. (If resistance is infinity, trans winding is cut).	Replace PCB transformer or PCB.	Applicable to model without dispenser.			
			PCB transformer temperature fuse is burnt out.						
		Defective PCB electric circuit parts.	Defective regulator IC (7812, 7805).	Check voltage at input/output terminals.	Replace regulator.	Refer to electric circuit in circuit explanation.			
							PCB electric terminal fuse is burnt out.	Check fuse in PCB electric terminal with a tester.	Replace PCB fuse.
							STR Parts are damaged.	Check if STR No. 2 and 3 pins are cut when power is off.	Replace parts.
	Abnormal display LCD operation	Bad connection between Main PCB and display circuit.	Lead Wire connecting main PCB and display PCB is cut or connector terminal connection is bad.	Check Lead Wire terminals connecting Main PCB and display PCB with a tester.	Reconnect Lead Wire and directly connect defective contact terminal to Lead Wire.				
Defective LCD.		Defective LCD.	Check if all LCD are on when Main PCB Test switch is pressed (or when both freezer key and power freezer key are pressed at the same time for more than one second.)	Replace display PCB.	Refer to display circuit in circuit explanation.				

Problems	Symptom	Causes		Checks	Measures	Remarks
Bad cooling.	Freezer temperature is high.	Compressor does not start.	Compressor Lead Wire is cut.	Check compressor Lead Wire with a tester.	Reconnect Lead Wire.	
			Defective compressor driving relay.	Measure voltage at PCB CON2 (3&9) after pressing main PCB test switch once. It is OK if voltage is normal.	Replace relay RY1 and RY2 or PCB.	Refer to load driving circuit in circuit explanation.
		Defective freezer sensor.	Defective Freezer sensor parts.	Check resistance of freezer sensor with a tester.	Replace freezer sensor.	Refer to resistance characteristics table of sensor in circuit. Refer to tables to page 29
			The wrong sensor has been installed. Order by model number and part number.	Confirm the color of sensor in circuits (main PCB sensor housing).	Repair main PCB sensor housing	explanation.
		Defective freezer fan motor.	Fan motor lead wire is cut.	Check fan motor lead wire with a tester.	Reconnect lead wire.	
			<ul style="list-style-type: none"> • Defective door switch (freezer, refrigerator, home bar). • Defective fan motor. • Defective fan motor driving relay. 	Measure the voltage between PCB power blue line and fan motor after pressing test switch of Main PCB. If the voltage is normal, it is OK.	<ul style="list-style-type: none"> • Replace door switch (freezer, refrigerator, and home bar). • Replace fan motor. • Replace relay RY5 & RY6 or PCB. 	Refer to load driving circuits in circuit explanation.
		Faulty defrost.		Refer to faulty defrost items in trouble diagnosis functions.		Refer to trouble diagnosis function.

Problem	Symptom	Cause		Check	Measure	Remarks	
Bad cooling	Wrong Refrigerator temperature.	Defective Step Motor Damper.	Check Step Motor damper motor and reed switch and lead wire are cut. Check Step Motor damper part.	Check if Step Motor damper motor and reed switch lead wire are cut with a tester.	Reconnect lead wire.		
				Refer to Step Motor damper in parts repair guide.	Replace Step Motor damper or refrigerator control box Assembly.		
			Check Step Motor damper Motor driving relay in PCB.	Refer to Step Motor damper in parts repair guide.	Replace relay or PCB.	Refer to single motor damper driving circuits in circuit explanation.	
			Foreign materials in Step Motor damper baffles.	Check Step Motor damper baffle visually.	Remove foreign materials.		
			Ice formation on Step Motor damper baffles.	Check if Step Motor damper Heater wire is cut with a tester.	Replace Step Motor damper or refrigerator control Box Assembly.		
		Defective refrigerator sensor	Defective refrigerator sensor parts.	Check the resistance of refrigerator sensor with a tester.	Replace refrigerator sensor.	Refer to sensor resistance characteristic table in circuit explanation.	
				Refrigerator sensor is substituted for other sensor.	Check the sensor color in the circuit. (main PCB sensor housing.)	Repair main PCB sensor housing.	
				Defective refrigerator sensor assembly condition.	Check if refrigerator sensor is not fixed at cover sensor but inner case visually.	Fix again the refrigerator sensor.	

Problems	Symptom	Causes	Checks	Measures	Remarks
Bad defrost.	Defrost is not working.	Defrost lead wire is cut.	Check if defrost lead wire is cut with a tester.	Reconnect Lead Wire.	
		Defective defrost driving relay.	Check the voltage of CON2 (1 and 7) with a tester after pressing main PCB test switch twice. If the voltage is normal then it is OK.	Replace relay (RY 7 and RY 3) or PCB.	Refer to load driving conditions check in circuit explanation.
		Defective defrost sensor parts.	Check the resistance of defrost sensor with a tester.	Replace defrost sensor.	Refer to sensor resistance characteristic table of circuit explanation.
Defective buzzer	Buzzer continuously rings or door opening alarm does not work.	Defective connecting lead wire from main PCB to door switch.	Check lead wire related to door switch with a tester.	Repair lead wire.	
		Defective door switch parts.	Refer to door switch in parts repair guide.	Replace door switch.	
Defective display button	Buzzer does not sound and buttons do not operate.	Key input wire is cut or bad connector terminal contact in main PCB and display PCB connecting lead wire.	Check input wire with a tester.	Reconnect lead wire and replace or directly connect bad contact terminal to lead wire.	Refer to display circuit in circuit explanation.
		Key is continuously depressed due to structural interference.	Disassemble frame display and confirm visually.	Adjust or replace interfering structures.	









Problems	Symptom	Causes	Checks	Measures	Remarks
Defective display button.	Buzzer does not sound and buttons do not operate.	Trouble mode indication.	Check trouble diagnosis function.	Repair troubles	Refer to mode indication in function explanations.
Door Buzzer	Buzzer continuously rings or door opening alarm does not work.	Defective connecting lead wire from main PCB to door switch.	Check lead wire associated with door switch.	Repair lead wire.	Check model with dispenser.
		Defective freezer compartment door switch parts.	Refer to door switch in parts repair guide.	Replace Freezer compartment door switch.	
Bad water/ice dispenser.	Ice and water are not dispensed.	Defective connecting lead wire from Main PCB to lever switch.	Check Lead Wire associated with lever switch with a tester.	Repair lead wire.	
		Defective lever switch parts	Refer to door switch in parts repair guide.	Replace lever switch.	
		Defective photo coupler IC parts.	Check voltage change at photo coupler output terminals with lever switch pressed. It is OK if voltage change is between 0V - 5V.	Replace photo coupler IC or PCB.	
		Defective relay associated with ice dispense (geared motor, cube, and dispenser solenoid).	Check relay (RY4, RY5, RY12) with a tester.	Replace defective relay.	
		Defective parts associated with ice dispense (geared motor, cube, and dispenser solenoid).	Check resistance of parts with a tester.	Replace defective parts.	
		Defective relay associated with water dispense.	Check relay (RY7) with a tester	Replace defective relay.	
	Defective parts associated with water dispenser.	Check resistance of parts with a tester.	Replace defective parts.		

3. Sealed System Heavy Repair

3-1. The Heavy Repair Standards for Refrigerator with R134a Refrigerant

No.	Items	Unit	Standards	Purposes	Remarks
1	Pipe and piping system opening time	Min	Pipe: Within 1 hour Comp: Within 10 min Drier: Within 20 min	To protect moisture penetration	The opening time should be reduced to a half of the standards during rain and rainy seasons (the penetration of water into the pipe is dangerous).
2	Welding	Nitrogen Pressure	Weld under nitrogen atmospher (N2 pressure 0.1~ 0.2 kg/cm2)	To protect oxide scale formation	Refer to repair note in each part. R134a refrigerant is more susceptible to leaks than R12 and requires more care during welding. Do not apply force to pipes before and after welding to protect pipe from cracking.
3	N2 Sealed parts	Leak	Sounds while removing bushing cap. Sound: usable No sound: Not usable	To protect moisture penetration	In case of evaporator parts, if it does not make noise when removing bushing cap blow dry air or N2 gas for more than 1 min use the parts.
	Refrigeration cycle Evacuation time	Min.	More than 40 min	To remove moisture	
	Vacuum degree	Torr	Below 0.5 (ref)		Only applicable to the model equipped with reverse flow protect plate.
	Vacuum	EA	High and low pressure side evacuates at the same time for models above 200 l		Vacuum efficiency can be improved by operating compressor during evacuation
	Vacuum piping	EA	Use R134a exclusive manifold	To protect mixing or mineral and ester oils	The bushing pipes for R12 refrigerant shall be melted when they are used for R134a refrigerant causes of leak.
	Pipe couple	EA	Use R134a exclusive manifold	To protect R12 Refrigerant mixing	
	Outlet (Socket) Plug		R134 exclusive R134 exclusive		
5	Refrigerant weighing	EA	Use R134a excluded weighing allowance $\pm 5g$. Note: Winter: $\pm 5g$. Summer: $\pm 5g$	Do not mix with R12 refrigerant	Do not weigh the refrigerant at too hot or too cold an areas ($25^{\circ}C$ ($77^{\circ}F$) is adequate) Use copper charging canister Socket. 2SV Plug: 2PV R134a Note: Do not burn O-ring (rubber) during welding
6	Drier replacement		Use R134a exclusive and remove for R134a refrigerant moisture Replace drier whenever from pipe repairing refrigerator cycle piping.		
7	Leak check		Do not use soapy water for check. It may be sucked into the pipe.	Detect refrigerant leak area	Check oil leak at refrigerant leak area. Use electronic leak detector if oil leak is not found The electronic leak detector is very sensitive to halogen gas in there. It also can detect R141b in urethane. Please practice therefore many times before use.

3-2. Summary Of Heavy Repair

Process	Contents	Tools
		
	<ul style="list-style-type: none"> - Cut charging pipe ends and discharge refrigerant from drier and compressor. 	Filter, side cutters
	<ul style="list-style-type: none"> - Use R134a oil and refrigerant for compressor and drier - Confirm N₂ sealing and packing conditions before use. Use good one for welding and assembly. - Weld under nitrogen gas atmosphere. (N₂ gas pressure: 0.1-0.2kg/cm²). - Repair in a clean and dry place. 	Pipe Cutter, Gas welder, N ₂ gas
	<ul style="list-style-type: none"> - Evacuate for more than forty minutes after connecting manifold gauge hose and vacuum pump to high (drier) and low (compressor refrigerant discharging parts) pressure sides. - Evacuation Speed: 113 liters/minute. 	Vacuum pump R134a exclusively, Manifold gauge.
	<ul style="list-style-type: none"> - Weigh and control the allowance of R134a charging canister in a vacuum conditions to be ±5 g with electronic scales and charge through compressor inlet (Charge while compressor operates). - Weld carefully after pinching off the inlet pipe. 	R134a exclusive charging canister (mass cylinder), refrigerant R134a manifold gauge, electronic scales, pinch-off plier, gas welding machine
	<ul style="list-style-type: none"> - Check leak at weld joints. <ul style="list-style-type: none"> □ Minute leak : Use electronic leak detector □ Big leak : Check visually. Note: Do not use soapy water for check. - Check cooling capacity <ol style="list-style-type: none"> 1. Check radiator manually to see if warm. 2. Check hot line pipe manually to see if warm. 3. Check frost formation on the whole surface of the evaporator. 	Electronic Leak Detector, Driver (Ruler).
	<ul style="list-style-type: none"> - Remove flux from the silver weld joints with soft brush or wet rag. Flux may be the cause of corrosion and leaks. - Clean R134a exclusive tools and store them in a clean tool box or in their place. 	Copper brush, Rag, Tool box
	<ul style="list-style-type: none"> - Installation should be conducted in accordance with the standard installation procedure. Leave space of more than 5 cm (2 inches) from the wall for compressor compartment cooling fan mounted model. 	

3-3. Precautions During Heavy Repair

Items	Precautions
1. Use of tools.	1) Use special parts and tools for R134a.
2. Recovery of refrigerant.	<p>1) Continue to recover the refrigerant for more than 5 minutes after turning the refrigerator off.</p> <p>2) Install a piercing type valve on the high pressure line (drier side). Then use the appropriate recovery equipment to recover the refrigerant from the system. When the refrigerant has been recovered, install a piercing type valve on the low pressure side. IT IS IMPORTANT TO OPEN THE SYSTEM IN THIS ORDER TO KEEP THE OIL FROM BEING FORCED OUT.</p> <p>The use of piercing type valves will allow future servicing and eliminates the possibility of a defective pinch off.</p> <div data-bbox="602 736 1265 1023" data-label="Diagram"> <p>The diagram illustrates a refrigeration cycle with the following components and connections: <ul style="list-style-type: none"> Compressor: A circular component on the left with two ports. The lower port is labeled 'Low pressure side' and has a circled '2' next to it. Condenser: A coil of four vertical tubes connected to the right side of the compressor. Hot Line: A vertical pipe connecting the top of the condenser to the top of the drier. Drier: A cylindrical component with a filter element inside, connected to the hot line. The bottom port is labeled 'High pressure side' and has a circled '1' next to it. Evaporator: A rectangular component with an 'X' inside, connected to the right side of the drier. Piping: Lines connect the compressor to the condenser, the condenser to the hot line, the hot line to the drier, and the drier to the evaporator. A return line connects the evaporator back to the compressor. </p> </div>
3. Replacement of drier.	1) Be sure to replace drier with R134a only when repairing pipes and injecting refrigerant.
4. Nitrogen blowing welding.	<p>1) Use pressurized nitrogen to prevent oxidation inside the piping. (Nitrogen pressure : 0.1~0.2 kg/cm².)</p>
5. Others.	<p>1) Only nitrogen or R134a should be used when cleaning the inside of piping of the sealed system.</p> <p>2) Check leakage with an electronic leakage tester.</p> <p>3) Be sure to use a pipe cutter when cutting pipes.</p> <p>4) Be careful not the water let intrude into the inside of the cycle.</p>

3-4. Practical Work For Heavy Repair

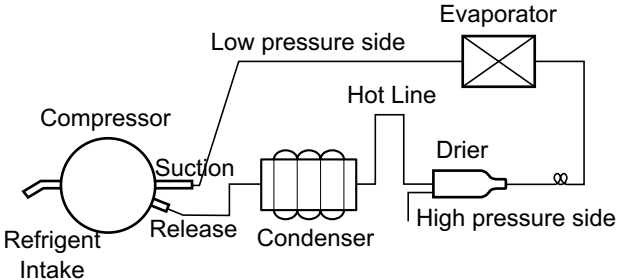
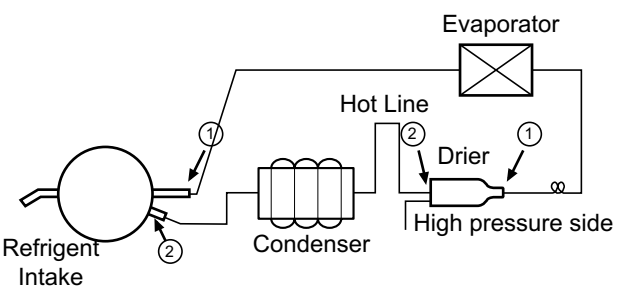
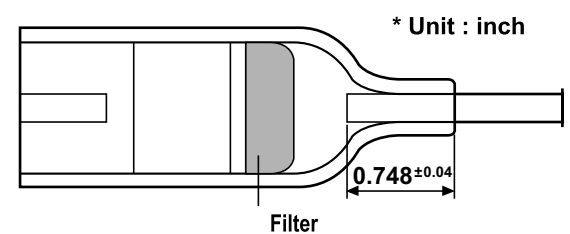
Items	Precautions
<p>1. Removal of residual refrigerant.</p>	<div style="display: flex; justify-content: space-between; align-items: flex-start;"> <div style="text-align: center;">  </div> <div style="width: 25%;"> <p>KEY POINT Observe the sequence for removal of refrigerant. (If not, compressor oil may leak.)</p> </div> </div> <p>1) Continue to recover the refrigerant for more than 5 minutes after turning the refrigerator off.</p> <p>2) Install a piercing type valve on the high pressure line (drier side). Then use the appropriate recovery equipment to recover the refrigerant from the system. When the refrigerant has been recovered, install a piercing type valve on the low pressure side. IT IS IMPORTANT TO OPEN THE SYSTEM IN THIS ORDER TO KEEP THE OIL FROM BEING FORCED OUT.</p> <p>The use of piercing type valves will allow future servicing and eliminates the possibility of a defective pinch off.</p>
<p>2. Nitrogen blowing welding.</p>	<div style="display: flex; justify-content: space-between; align-items: flex-start;"> <div style="text-align: center;">  </div> <div style="width: 25%;"> <p>KEY POINT Welding without nitrogen blowing produces oxidized scales inside a pipe, which affect performance and reliability of a product.</p> </div> </div> <p>When replacing a drier: Weld ① And ② parts by blowing nitrogen (0.1~0.2kg/cm²) to high pressure side after assembling a drier.</p> <p>When replacing a compressor: Weld ① And ② parts by blowing nitrogen to the low pressure side.</p> <p>Note) For other parts, nitrogen blowing is not necessary because it does not produce oxidized scales inside pipe because of its short welding time.</p>
<p>3. Replacement of drier.</p>	<div style="display: flex; justify-content: space-between; align-items: flex-start;"> <div style="text-align: center;">  <p>* Unit : inch</p> <p>0.748±0.04</p> <p>Filter</p> </div> <div style="width: 25%;"> <p>KEY POINT Be sure to check the inserted length of capillary tube when it is inserted. (If inserted too far, the capillary tube will be blocked by the filter.)</p> </div> </div> <p>Inserting a capillary tube Measure distance with a ruler and put a mark(0.748 ±0.04)on the capillary tube. Insert tube to the mark and weld it</p>

Items	Precautions
4. Vacuum degassing.	<div data-bbox="532 357 1385 1044" data-label="Diagram"> </div> <p data-bbox="475 1087 667 1112">Pipe Connection</p> <p data-bbox="475 1123 1242 1193">Connect the red hose to the high pressure side and the blue hose to the low pressure side.</p> <p data-bbox="475 1204 688 1229">Vacuum Sequence</p> <p data-bbox="475 1240 1203 1272">Open valves ① and ② and evacuate for 40 minutes. Close valve ①.</p> <p data-bbox="1235 921 1365 946">KEY POINT</p> <ul data-bbox="1235 953 1472 1219" style="list-style-type: none"> - If power is applied during vacuum degassing, vacuum degassing shall be more effective. - Run the compressor while charging the system. It is easier and works better.
5. Refrigerant charging.	<p data-bbox="475 1347 699 1372">Charging sequence</p> <ol data-bbox="475 1389 1365 1538" style="list-style-type: none"> 1) Check the amount of refrigerant supplied to each model after completing vacuum degassing. 2) Evacuate charging canister with a vacuum pump. 3) Measure the amount of refrigerant charged. <ul data-bbox="505 1549 1472 1698" style="list-style-type: none"> - Measure the weight of an evacuated charging canister with an electronic scale. - Charge refrigerant into a charging canister and measure the weight. Calculate the weight of refrigerant charged into the charging canister by subtracting the weight of an evacuated charging canister. <div data-bbox="475 1708 959 2008" data-label="Diagram"> </div> <p data-bbox="1219 1672 1349 1698">KEY POINT</p> <ul data-bbox="1219 1704 1472 1874" style="list-style-type: none"> - Be sure to charge the refrigerant at around 25°C [77°F]. - Be sure to keep -5g in the winter and +5g in summer. <div data-bbox="894 1896 1438 1932" data-label="Text" style="border: 1px solid black; padding: 2px;"> <p data-bbox="911 1900 1422 1927">Calculation of amount of refrigerant charged</p> </div> <p data-bbox="805 1942 1430 2002">the amount of refrigerant charged= weight after charging - weight before charging (weight of an evacuated cylinder)</p>

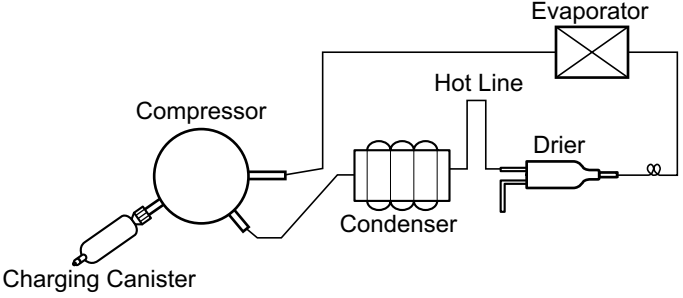
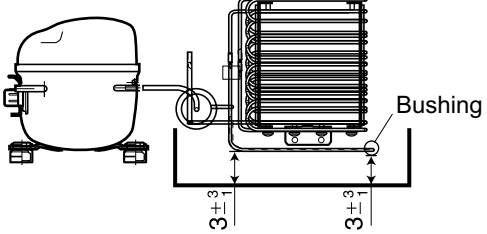
Items	Precautions
	<div style="text-align: center;">  </div> <p>4) Refrigerant Charging Charge refrigerant while operating a compressor as shown above.</p> <p>5) Pinch the charging pipe with a pinch-off plier after completion of charging.</p> <p>6) Braze the end of a pinched charging pipe with copper brazer and take a gas leakage test on the welded parts.</p>
6. Gas-leakage test	* Test for leaks on the welded or suspicious area with an electronic leakage tester.
7. Pipe arrangement in each cycle	<p>When replacing components, be sure each pipe is replaced in its original position before closing the cover of the mechanical area.</p> <div style="text-align: center;">  </div>

3-5. Standard Regulations For Heavy Repair

- 1) Observe the safety precautions for gas handling.
- 2) Use JIG (or a wet towel) in order to prevent electric wires from burning during welding. (In order to prevent insulation break and accident.)
- 3) The inner case will melt and the insulation will burn.
- 4) The copper piping will oxidize.
- 5) Do not allow aluminum and copper pipes to touch. (In order to prevent corrosion.)
- 6) Observe that the inserted length of a capillary tube into a drier should be 0.748 ± 0.04

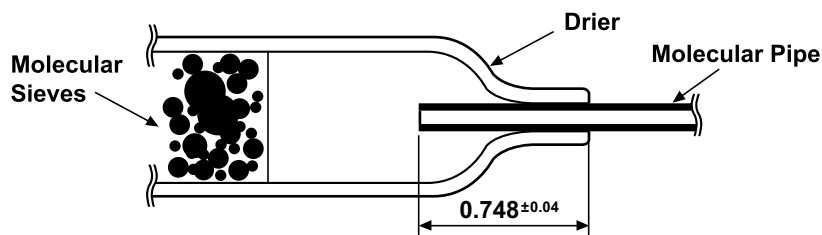

- 7) Make sure that the inner diameter is not distorted while cutting a capillary tube.
- 8) Be sure that the suction pipe and the filling tube should not be substituted each other during welding. (High efficiency pump.)

3-6. Brazing Reference Drawings

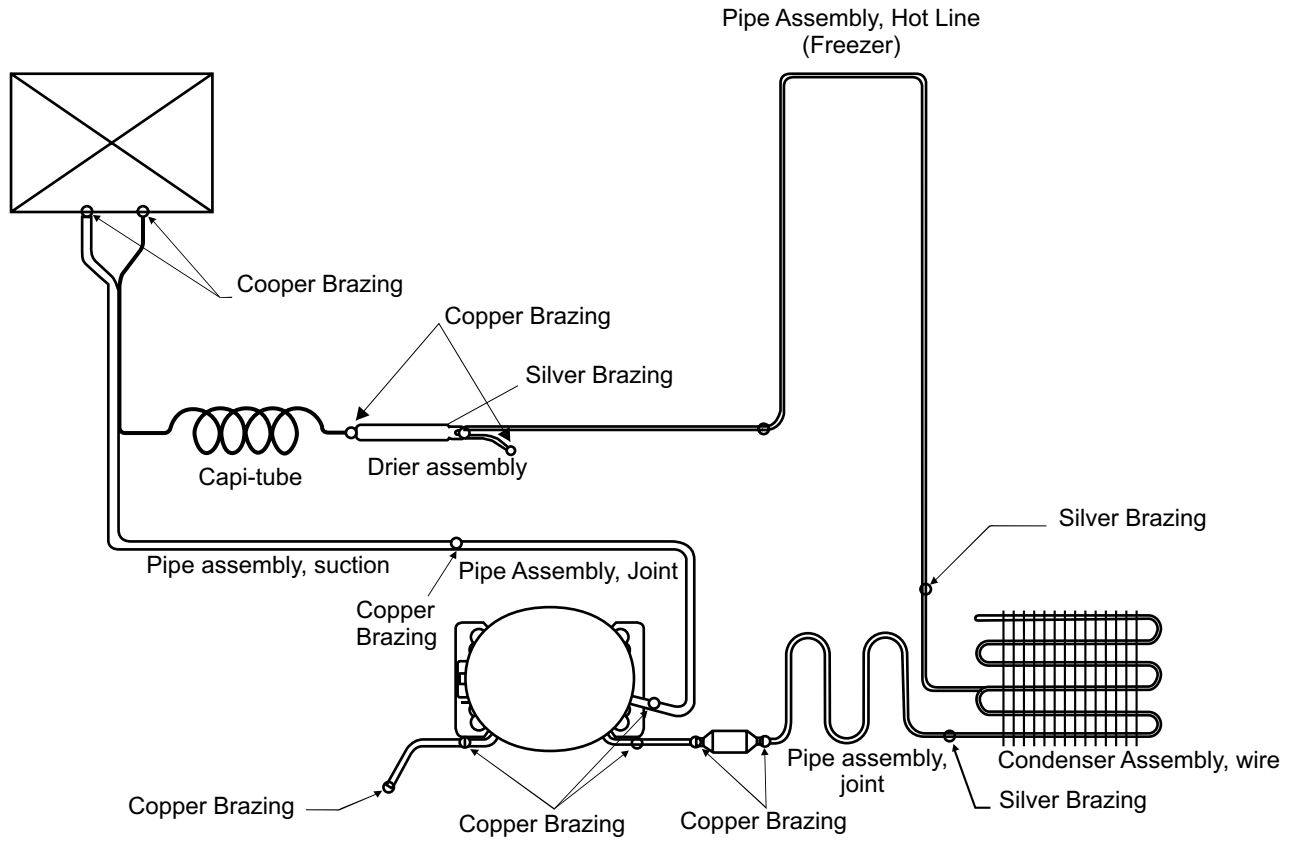

4. HOW TO DEAL WITH CLAIMS

4-1. Sound

Problems	Checks and Measures
<p>Hiss sounds</p>	<p>Explain general principles of sounds.</p> <ul style="list-style-type: none"> • All refrigerators make noises when they run. The compressor and fan produce sounds. There is a fan in the freezer compartment which blows cool air to freezer and refrigerator compartments. Hiss sounds are heard when the air passes through the narrow holes into the freezer and refrigerator compartments. <p>Cooling Fan sound in the compressor compartment.</p> <ul style="list-style-type: none"> • There is a fan on the back of the refrigerator which cools the compressor compartment. If there is a small space between the refrigerator and the wall, the air circulation sounds may be noticeable. <p>Noise of Compressor.</p> <ul style="list-style-type: none"> • This operating sound happens when the compressor compresses the refrigerant. The compressor rotates at 3600 RPM. The sound of compressor Bigger refrigerators make more noise than small ones
<p>Click sounds</p>	<p>Explain the principles of temperature change.</p> <ul style="list-style-type: none"> • The sounds happens when pipes and internal evaporator in the refrigerator compartment expand and contract as the temperature changes during the refrigerator operation. This sound also happens during defrosting, twice a day, when the ice on the evaporator melts.
<p>Clunk sound</p>	<p>Explain that it comes from the compressor when the refrigerator starts.</p> <ul style="list-style-type: none"> • When the refrigerator operates, the piston and motor in the compressor rotate at 3600 RPM. This sound is caused by the vibration of motor and piston when they start and finish their operation. This phenomenon can be compared with that of cars. When an automobile engine starts, it is loud at first but quiets down quickly. When the engine stops, so does the vibration.
<p>Vibration sound</p>	<p>Check the sound whether it comes from the pipes vibration and friction.</p> <ul style="list-style-type: none"> • Insert bushing or leave a space between pipes to avoid the noise. • Fix the fan blade if it is hitting on the shroud • Fix the drip tray if it is loosened. <p>Sound depends on the installation location.</p> <ul style="list-style-type: none"> • Sound becomes louder if the refrigerator is installed on a wooden floor or near a wooden wall. Move it to the another location. • If the refrigerator is not leveled properly, a small vibration can make a loud sound. Please adjust the level of the refrigerator.

Problems	Checks and Measures
<p>Sounds of water flowing</p>	<p>Explain the flow of refrigerant.</p> <ul style="list-style-type: none"> • When the refrigerator stops, the water flowing sound happens. This sound happens when the liquid or vapor refrigerant flows from the evaporator to compressor.
<p>Click sounds</p>	<p>Explain the characteristics of moving parts.</p> <ul style="list-style-type: none"> • This noise comes from the MICOM controller's switch on the top of the refrigerator when it is turned on and off.
<p>Noise of Icemaker operation (applicable to model with Icemaker).</p> <ul style="list-style-type: none"> - Noise produced by ice dropping and hitting ice bin. - Noise from motor sounds Hiss . 	<p>Explain the procedure and principles of Icemaker operation.</p> <ul style="list-style-type: none"> • Automatic Icemaker repeats the cycle of water supplying → Icemaking → ice ejection. When water is supplied, the water supply valve in the machine room makes sounds like Hiss and water flowing also makes sound. When water freezes, clicking sounds are heard. When ice is being ejected, sounds like Hiss produced by a motor to rotate an ice tray and ice dropping and hitting ice bin sounds are also heard.
<p>Noise when supplying water.</p>	<p>Explain the principles of water supplied to dispenser.</p> <ul style="list-style-type: none"> • When the water supply button in the dispenser is pressed, the water supply valve in the compressor compartment opens and let the water flow to the water tank in the lower part of the refrigerator compartment. The water is dispensed by this pressure. When this happens, motor sound and water flowing sound are heard.
<p>Noise when supplying ice.</p>	<p>Explain the principles of ice supply and procedure of crushed icemaking in a dispenser.</p> <ul style="list-style-type: none"> • When ice cube button is pressed, ice stored in the ice bin is moved by an auger and dispensed. If crushed ice button is pressed, the ice cube is crushed. When this happens, ice crushing and hitting ice bin sounds are heard.

4-2. Measures for Symptoms on Temperature

Problems	Checks and Measures
Refrigeration is weak.	<p>Check temperature set in the temperature control knob.</p> <ul style="list-style-type: none"> • Refrigerator is generally delivered with the button set at normal use (MID). But customer can adjust the temperature set depending on their habit and taste. If you feel the refrigeration is weak, then set the temperature control button at strong position. If you adjust the button in the freezer compartment as well, the refrigeration is stronger than adjusting refrigerator only.
The food in the chilled drawer is not frozen but defrosted	<p>The chilled drawer does not freeze food.</p> <ul style="list-style-type: none"> • Use chilled drawer for storing fresh meat or fish for short periods. For storing for a long periods or freezing food, use a freezer compartment. It is normal that frozen foods thaw above the freezing temperature (in the chilled drawer).
Refrigerator water is not cool.	<p>Check the water storage location.</p> <ul style="list-style-type: none"> • If water is kept in the door rack, move it to a refrigerator shelf. It will then become cooler.
Ice cream softens.	<p>Explain the characteristics of ice cream.</p> <ul style="list-style-type: none"> • The freezing point of ice cream is below -15°C[5°F]. Therefore ice cream may melt if it is stored in the door rack. • Store ice cream in a cold place or set the temperature control button of a freezer at strong position.
Refrigeration is too strong.	<p>Check the position of temperature control button.</p> <ul style="list-style-type: none"> • Check if refrigeration is strong in whole area of the refrigerator or partly near the outlet of the cooling air. If it is strong in whole area, set the control button at weak. If it is strong only near the outlet of cool air, keep food (especially damp foods and easily frozen foods) away from the outlet.
Vegetables are frozen.	<p>Check the vegetables storage.</p> <ul style="list-style-type: none"> • If vegetables are stored in the refrigerator shelf or chilled drawer instead of vegetable drawer, they will be frozen. Set the control button at weak if they are also frozen in the vegetable drawer.
The food stored at inside of the shelf freezes even the control button is set at MID .	<p>Check if food is stored near the outlet of the cooling air.</p> <ul style="list-style-type: none"> • The temperature at cooling air outlet is always below the freezing point. Do not store food near the outlet of the cooling air as it block the air circulation. Do not block the outlet. If the outlet of the cooling air is blocked, the refrigerator compartment will not be cooled.

4-3. Odor and Frost

Problems	Checks and Measures
Odor in the refrigerator compartment.	<p>Explain the basic principles of food odor.</p> <ul style="list-style-type: none"> • Each food has its own particular odor. Therefore it is impossible to prevent or avoid food odor completely when food is stored in the completely sealed refrigerator compartment. The deodorizer can absorb some portions of the odor but not completely. The intensity of odor depends on refrigerator conditions and environments. <p>Check the temperature control button and set at strong.</p> <ul style="list-style-type: none"> • Clean inside of the refrigerator with detergent and remove moisture. Dry inside the refrigerator by opening the door for about 3 or 4 hours and then set the temperature control button at strong .
Frost in the freezer compartment	<p>Explain the basic principles of frost formation.</p> <ul style="list-style-type: none"> • The main causes for frosting: <ul style="list-style-type: none"> - Door was left open. - Air penetration through the gasket - Too frequent door opening. (parties. etc.) - Hot foods are stored before they are cooled down. The temperature of freezer is -19°C[-2.2°F]. if temperature is set at MID. If hot air comes into the refrigerator, fine frost forms as cold air mixes with hot air. If this happens quite often, much frost forms inside of the refrigerator. If the door is left open in Summer, ice may form inside of the refrigerator.
Frost in ice tray.	<p>Explain basic principles of frost formation.</p> <ul style="list-style-type: none"> • When ice tray with full of water is put into a freezer compartment, the water evaporates. If cool air fan operates, the moisture attached to the jaw (protruded part) of ice mold will freeze and form frost. If warm water was put into the ice mold, the situation will become worse.

4-4. Others

Problems	Checks and Measures
The refrigerator case is hot.	<p>Explain the principles of radiator.</p> <ul style="list-style-type: none"> • The radiator pipes are installed in the refrigerator case and partition plate between the refrigerator and the freezer compartment in order to prevent condensation formation. Particularly in summer or after installation of refrigerator, it may feel hot but it is normal. If there is not enough space to dissipate heat, it can be hotter due to lack of heat radiation. Please install a refrigerator in a well-ventilated place and leave the clearance between refrigerator and wall:
Small holes in a door liner	<p>Explain that the hole is for releasing gas.</p> <ul style="list-style-type: none"> • A small hole in the door liner is for releasing gas during insulation materials lining work. With a releasing hole, forming can be easily done .
Electric bills are too much.	<p>Explain that the hole is to allow the air to escape when vacuum forming plastic parts and pumping foam insulation into cavities.</p> <p>NOTE! Holes and releasing gas appear to be very crude and would not be acceptable in a manual.</p> <p>There are small holes in the plastic liner of some parts of the refrigerator. These holes allow plastic parts to be injection molded and vacuum formed by allowing air bubbles to be expelled. They also allow foam insulation to be pumped into cavities where air bubbles may build up.</p>
Condensation on the inside wall of the refrigerator compartment and the cover of properly vegetable drawer.	<p>Explain how to store foods</p> <ul style="list-style-type: none"> • Condensation forms when refrigerator is installed at damp area, door is frequently opened, and wet foods are not stored in the air tight container or wrapped. Be sure to store wet foods in airtight containers or securely covered in plastic wrap.
When is the power connected?	<p>When should the power be connected ?</p> <ul style="list-style-type: none"> • You can connect the power immediately after installation. However, if the refrigerator was laid flat before or during installation, you must stand it upright for 6 hours before plugging it in. This allows the refrigerant oils to return to the sump in the compressor. If you operate the refrigerator before the oil has had a chance to settle, you could damage the compressor.
Door does not open properly.	<p>Refrigerator compartment door does not open properly.</p> <ul style="list-style-type: none"> • When the door is open, warm open air comes into the compartment and is mixed up with cool air. This mixed air shall be compressed and increase the internal pressure when door is closed. This causes the door stucked closely to the refrigerator in a moment. (If the refrigerator is used for a long time, it will open smoothly.) <p>When the refrigerator compartment door is opened and closed, the freezer compartment door moves up and down.</p> <ul style="list-style-type: none"> • When the refrigerator compartment door is opened and closed, fresh air comes into the freezer compartment and moves up and down the freezer compartment door. <p>Door opens too easily.</p> <ul style="list-style-type: none"> • There is a magnet in the gasket so it closes securely without a gap. It can be held open easily if something is in the way and obstructs the door's closing <p>A door does not close properly.</p> <ul style="list-style-type: none"> • If the refrigerator is not properly leveled, the doors will not close easily. Adjust the level using the leveling screws under the front of the refrigerator.

10. EXPLODED VIEW

FREEZER DOOR

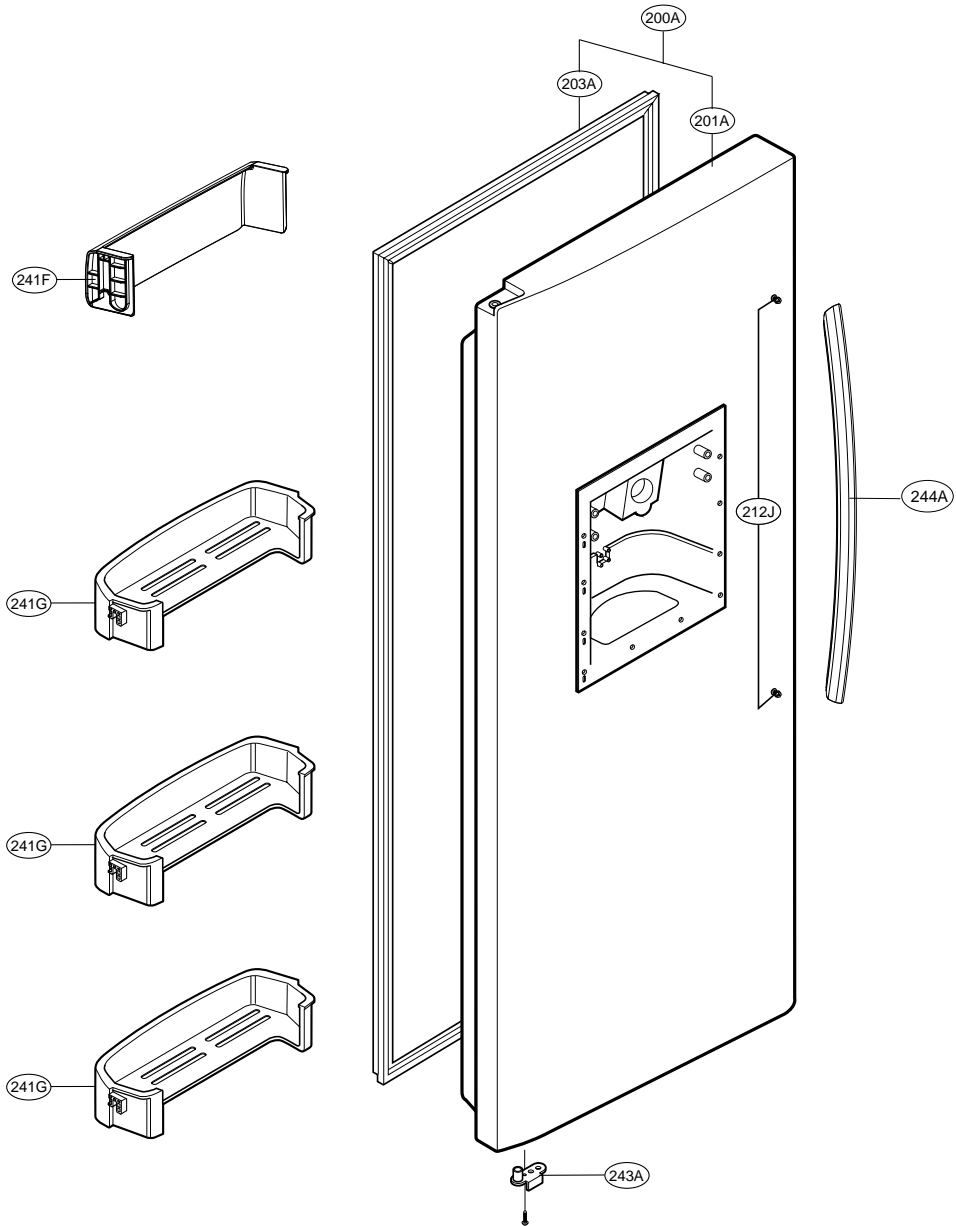

EXPLODED VIEW

REFRIGERATOR DOOR

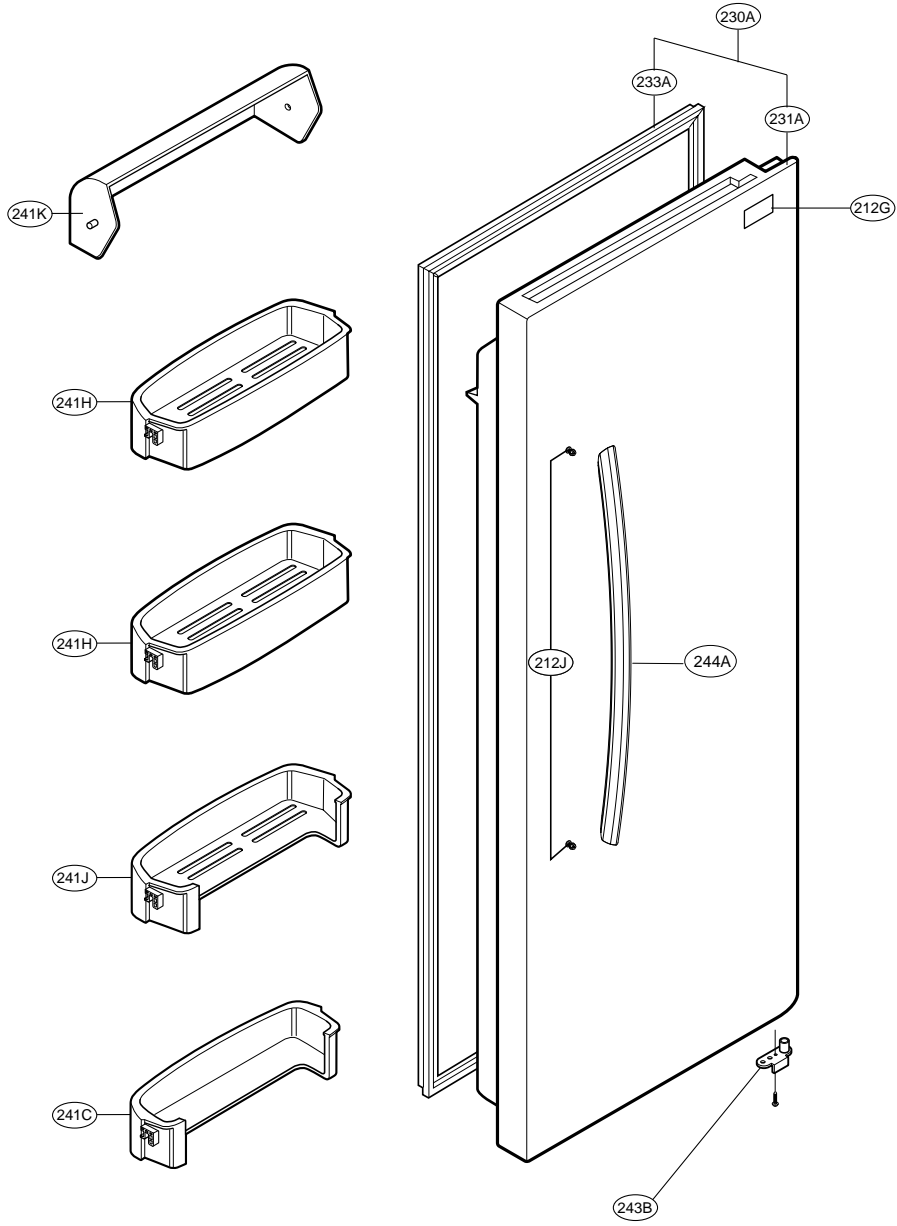

EXPLODED VIEW

FREEZER COMPARTMENT

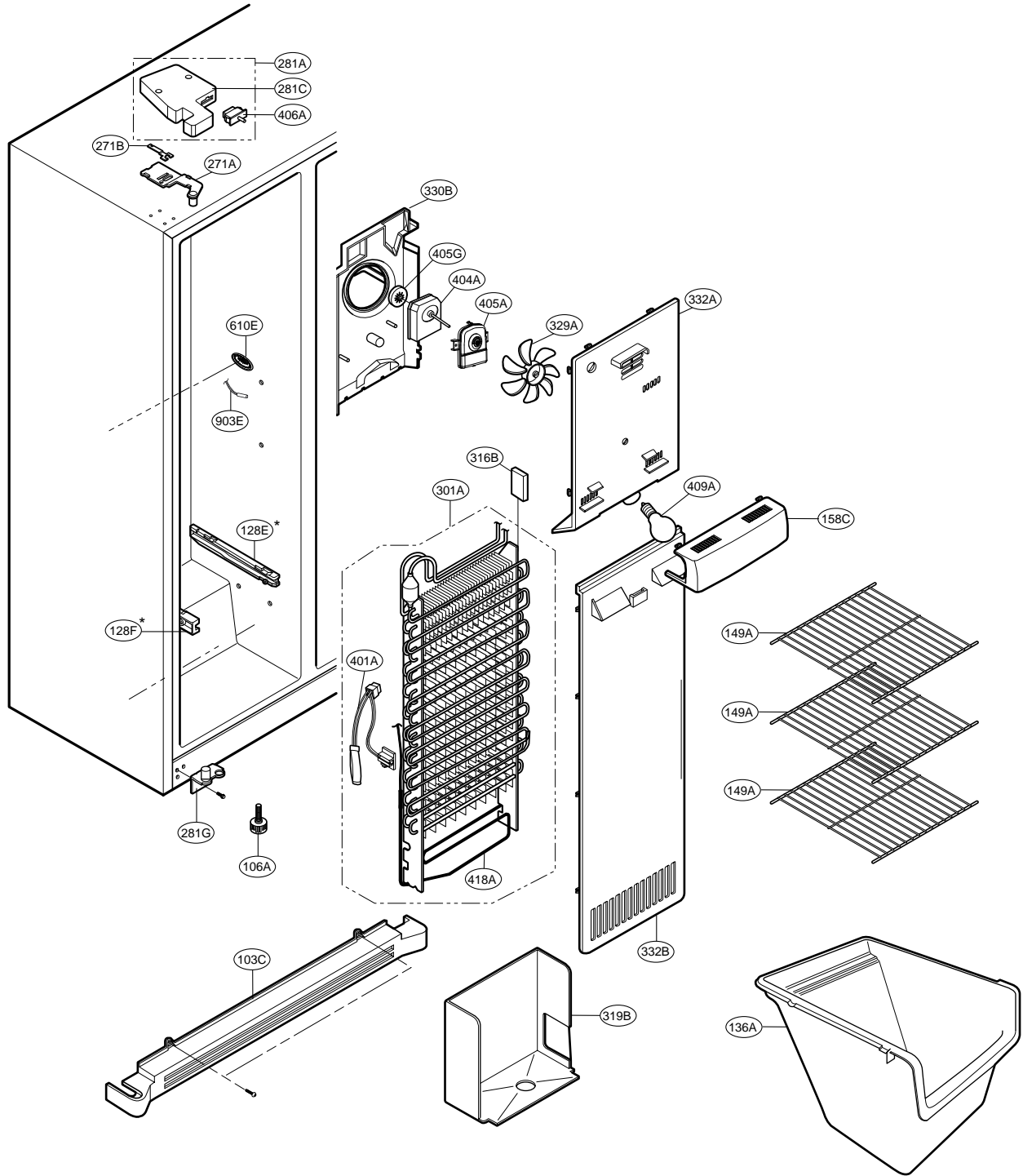

EXPLODED VIEW

REFRIGERATOR COMPARTMENT

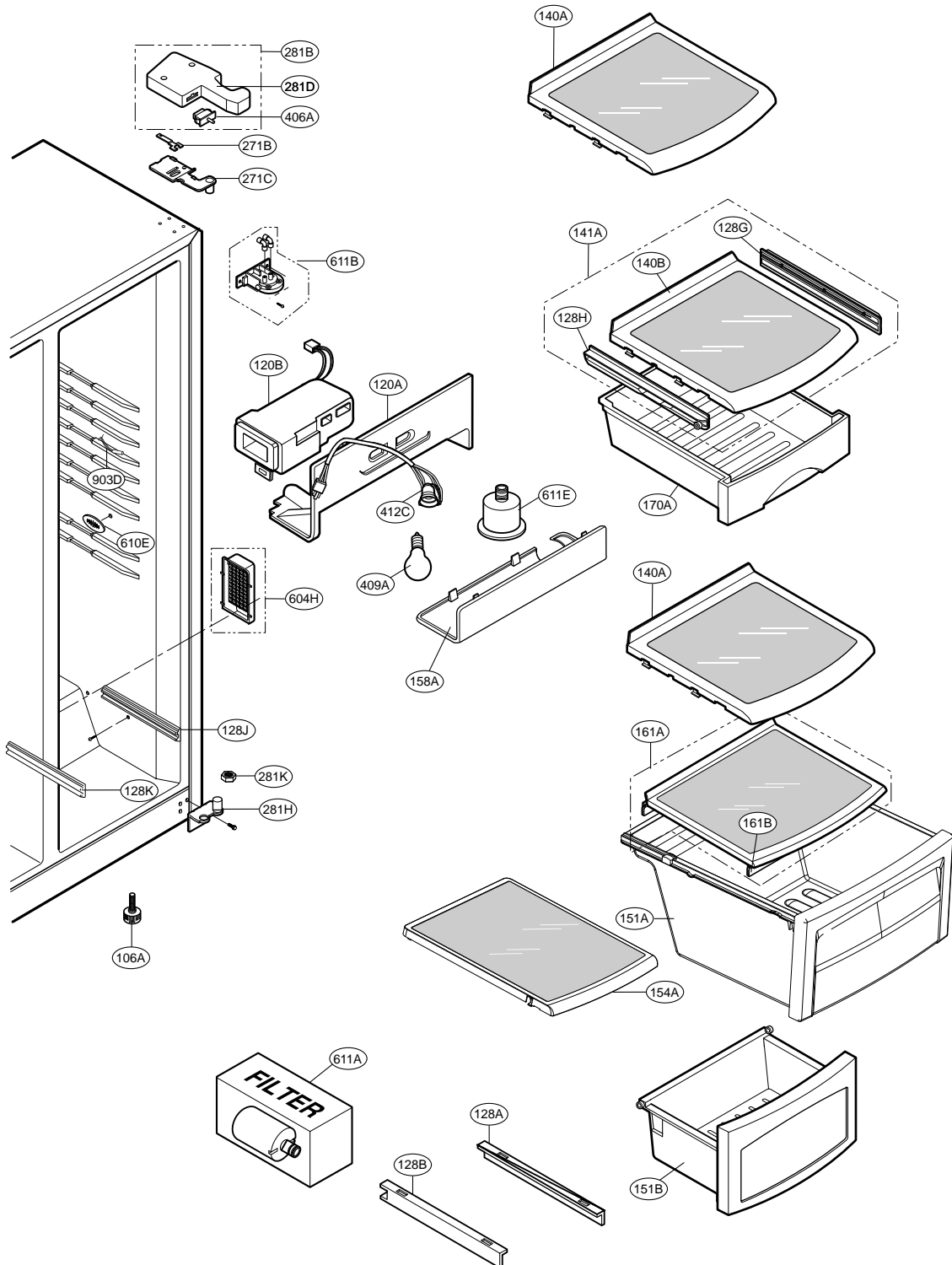

EXPLODED VIEW

ICE & WATER PARTS

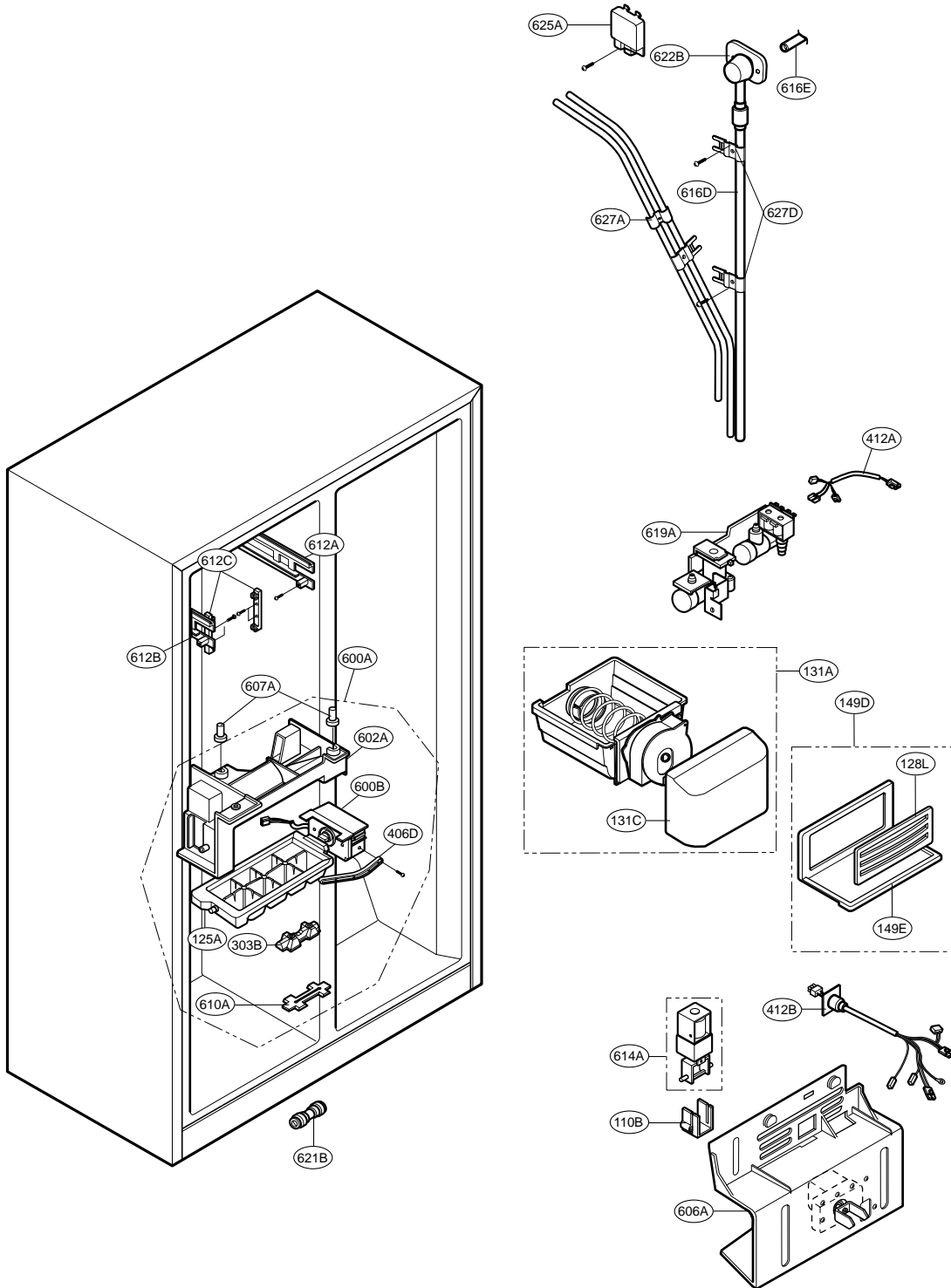

EXPLODED VIEW

MECHANICAL COMPARTMENT

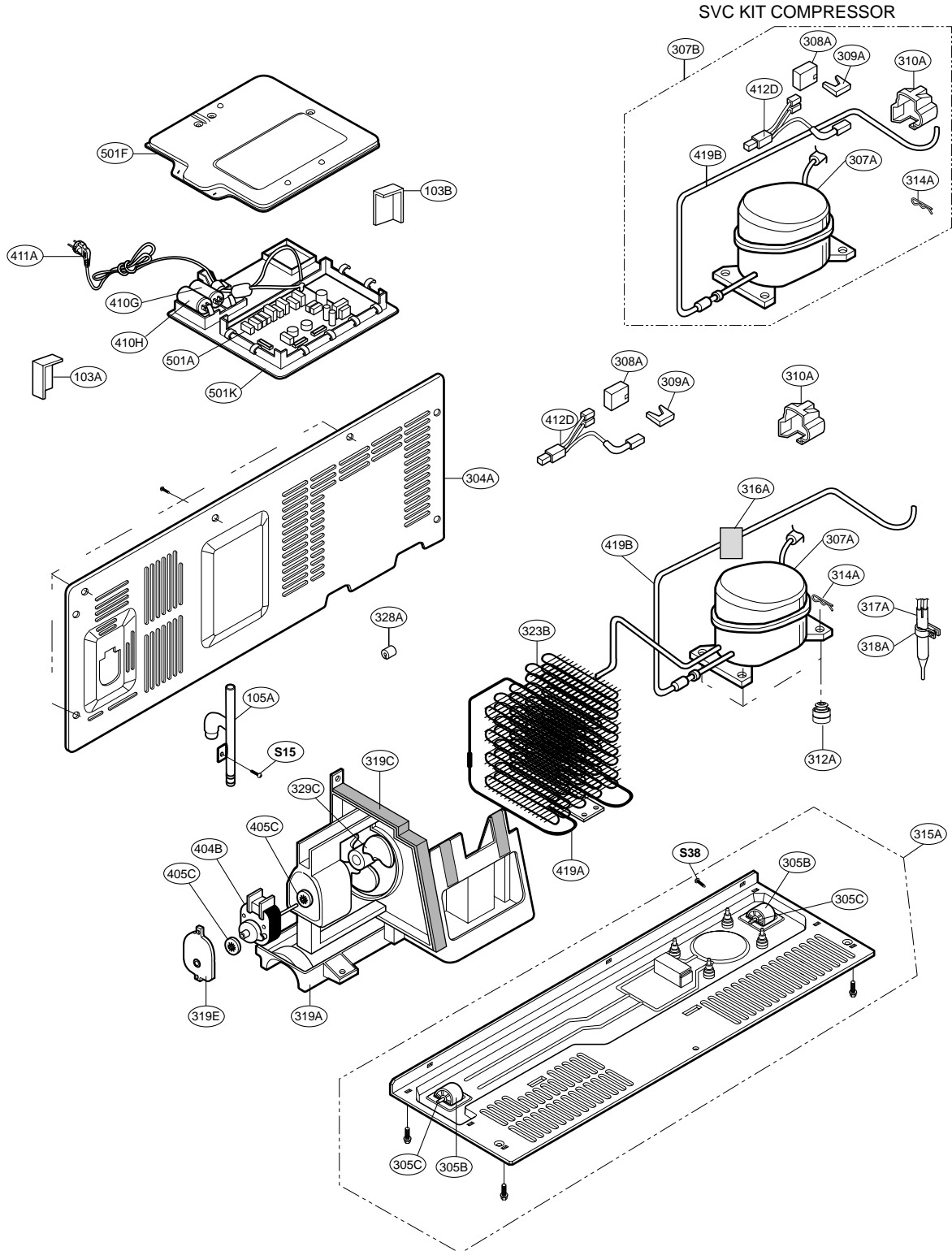

EXPLODED VIEW

DISPENSER PARTS

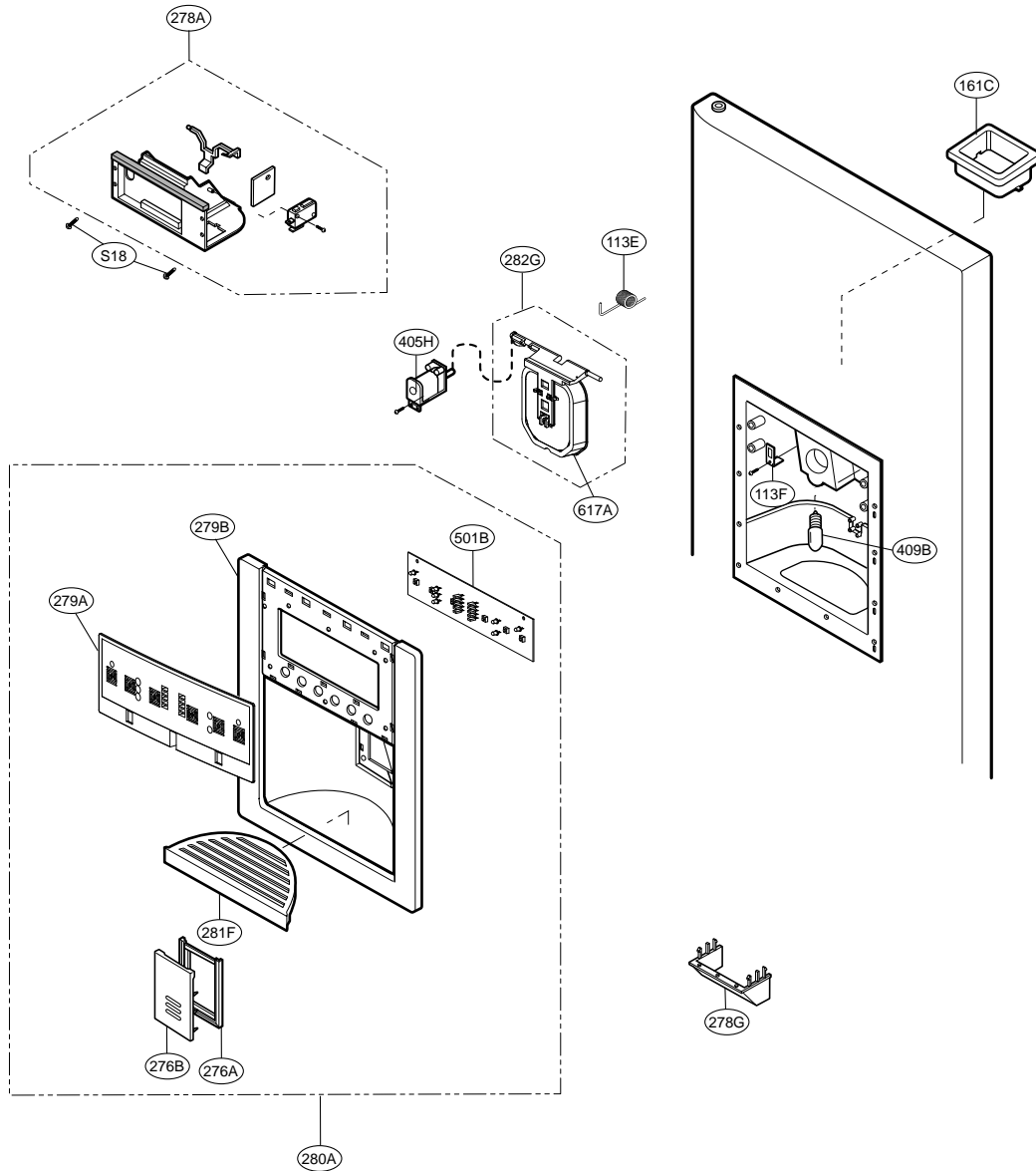

SERVICE KITS

Service Kits were created in order to facilitate to technician the way to replace previous components that due to changes for structure, material o improves, can not be used individually.

Please refer to next table, and identify it in your exploded view.

Loc No.	Part Number Kit	Description	Include			Reason	Serial
			Loc No	Part No.	Description		
307B	ACF67062310	Compressor Assembly	310A	3550JA2042C	Cover,PTC	In order to use it with objective to has the option of request it for a future compressor change and make interchangeable. This kit is completly interchangeable for any compressor model found for LSC27910 models.	For all production.
			412D	6877JB2040H	Harness Assembly		
			419B	MGE58810302	Pipe,Joint		
			412D	MJB61877901	Stopper,Compressor		
			307A	TCA30358201	Compressor,Set Assembly		
			308A	6748C-0002C	Thermistor Assembly,PTC		
			309A	6750C-0004R	Overload Protect		



MFL62215907

OCTOBER 2009

REVIEW 01