

This Owner's Manual is provided and hosted by [Appliance Factory Parts](#).



HAMILTON BEACH 48465 Owner's Manual

[Shop genuine replacement parts for HAMILTON
BEACH 48465](#)



[Find Your HAMILTON BEACH Small Appliance Parts - Select From 252 Models](#)

----- Manual continues below -----

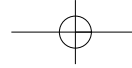

READ BEFORE USE
LIRE AVANT UTILISATION
LEA ANTES DE USAR

Visit hamiltonbeach.com for delicious recipes, tips, and to register your product online!



Consultez hamiltonbeach.ca pour de délicieuses recettes, des conseils pratiques et pour enregistrer votre produit !

¡Visite hamiltonbeach.com.mx para recetas deliciosas, consejos, y para registrar su producto en línea!

Questions?

Please call us – our friendly associates are ready to help.
USA: 1.800.851.8900

Questions ?

N'hésitez pas à nous appeler – nos associés s'empresseront de vous aider.
CAN: 1.800.267.2826

¿Preguntas?

Por favor llámenos – nuestros amables representantes están listos para ayudar.

MEX: 01 800 71 16 100

Le invitamos a leer cuidadosamente este instructivo antes de usar su aparato.

Hami

BrewS

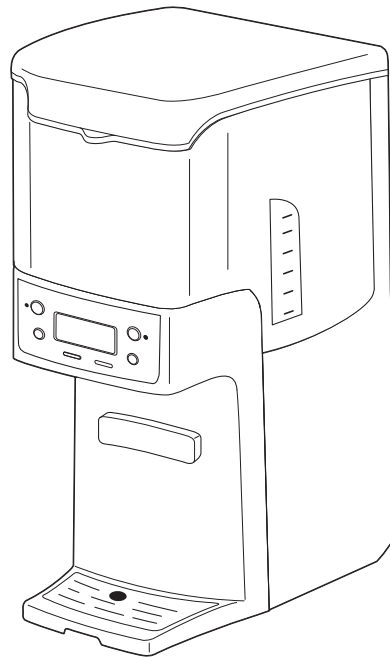

Engl
Fran
Espa

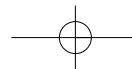

IMPORTANT SAFEGUARDS

When using electrical appliances, basic safety precautions should always be followed to reduce the risk of fire, electrical shock, or injury to persons, including the following:

1. Read all instructions.
2. Do not touch hot surfaces. Use handles or knobs. Care must be taken, as burns can occur from touching hot parts or from spilled, hot liquid.
3. To protect against electric shock, do not place cord, plug, or BrewStation® in water or other liquid.
4. Close supervision is necessary when any appliance is used by or near children.
5. Unplug from outlet when either the BrewStation® or clock is not in use and before cleaning. Allow to cool before putting on or taking off parts and before cleaning the appliance.
6. Scalding may occur if the lid is lifted during the brewing cycle. Do not open lid until coffeemaker has cooled completely.
7. BrewStation® must be operated on a flat surface away from the edge of counter to prevent accidental tipping.
8. Do not operate any appliance with a damaged cord or plug, or after the appliance malfunctions or is dropped or damaged in any manner. Call our toll-free customer service number for information on examination, repair, or adjustment.
9. The use of accessory attachments not recommended by the appliance manufacturer may cause injuries.
10. Do not use outdoors.
11. Do not let cord hang over edge of table or rest on hot surfaces, including stove.
12. The coffee tank is designed for use with the coffee maker. It must never be used on a range top or in a microwave oven.
13. Do not place BrewStation® on or near a hot burner or in a heated oven.
14. To disconnect BrewStation®, turn controls off and unplug from wall outlet.
15. **WARNING!** To reduce the risk of fire or electrical shock, do not remove the bottom cover. No users should be inside. Repair should be done by authorized service personnel only.
16. Do not use appliance for other than intended use.

SAVE THESE INSTRUCTIONS!

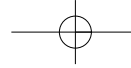

IMPORTANT

Never use coffee tank to pour hot coffee or carry hot coffee.

Handle coffee tank when it holds only cold water.



Additional Information

- If overflow occurs: Let unit, coffee, and grounds cool completely before attempting any cleanup.
- Use only brand-name, high-quality filters.
- Use only 1 tablespoon of ground coffee for each cup of water.
- Use coffeemaker cleaner to prevent hard water deposits that affect coffeemaker performance. Clean monthly.
- Do not clean coffee tank in dishwasher.
- Read instructions before using.

OTHER CONSUMER SAFETY INFORMATION

This appliance is intended for household use only.

WARNING! Shock Hazard: This appliance has a polarized plug (one wide blade) that reduces the risk of electric shock. The plug fits only one way into a polarized outlet. Do not defeat the safety purpose of the plug by modifying the plug in any way or using an adapter. If the plug does not fit, reverse the plug. If it still does not fit, have an electrician replace the outlet.

The length of the cord used on this appliance was selected to reduce the hazards of becoming tangled in, or tripping over a longer cord. If a longer cord is necessary, an approved extension

cord may be used. The electrical rating of the extension cord must be equal to or greater than the rating of the appliance. Care must be taken to arrange the extension cord so it does not drape over the countertop or tabletop where it can be pulled on by children or accidentally tripped over.

To avoid an electrical circuit overload, do not use other high-wattage appliance on the same circuit with y

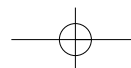

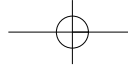

Parts and Features

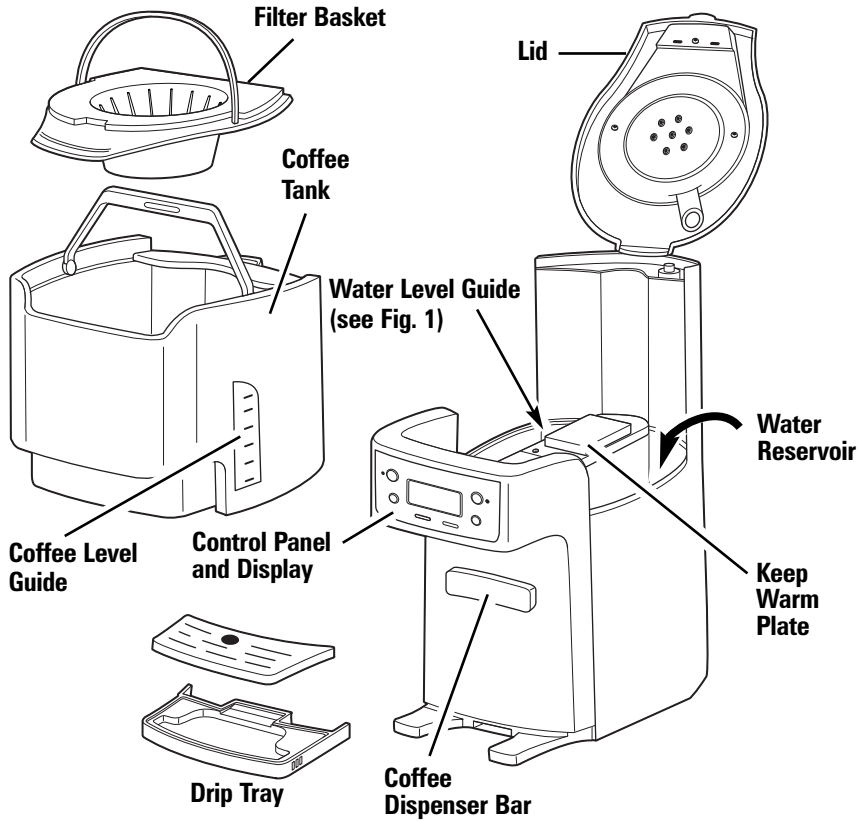

Optional Accessories

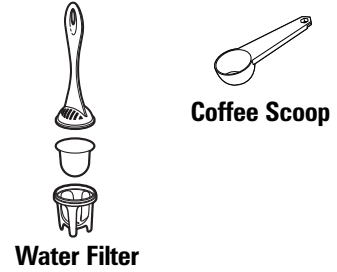

To Order Accessories
1.800.851.8900
1.800.267.2826 (Toll Free)
01.800.71.16.100
or visit hamiltonbeats.com

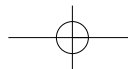
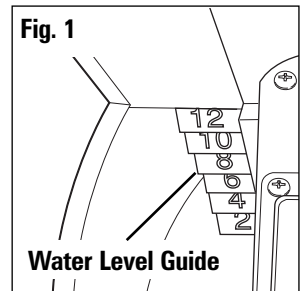

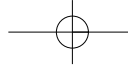

How To Make Coffee

Before first use: Wash coffee tank, filter basket, and drip tray in hot, soapy water. NEVER put the coffee tank in dishwasher.

BrewStation® can be programmed to automatically shut off in 0 (for Iced Coffee), 1, 2, 3, or 4 hours as desired. Default is 4 hours for automatic shutoff.

⚠ WARNING Burn Hazard.

- Never use coffee tank to pour or carry hot coffee.
- Handle coffee tank only when holding cold water for fill and to clean tank after BrewStation® has been shut off.
- If BrewStation® overflows, unplug unit. Allow unit, coffee, or grounds to cool before cleaning unit, coffee, or grounds.

*Coffee scoop is optional feature on select models.

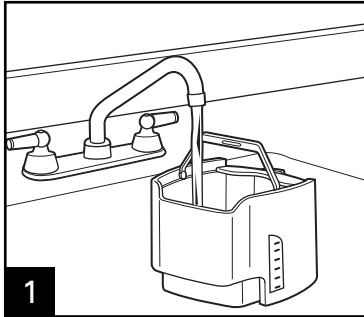

1

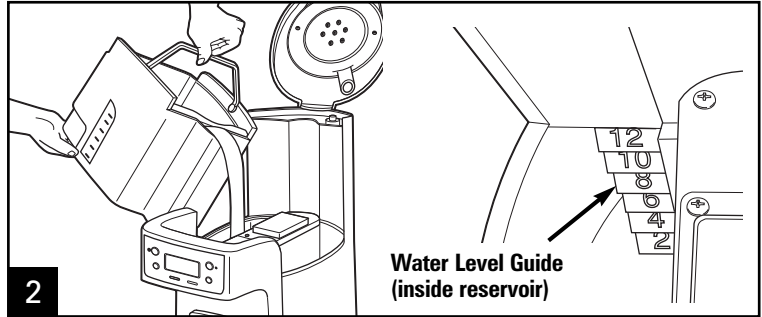

2

Water Level Guide (inside reservoir)

Normal Am
1 scoop* or 1

Maximum
Drip Coffee

Coffee
Regular
Decaf

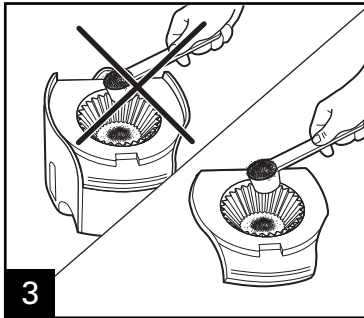

3

Avoid getting coffee grounds in any other areas of the BrewStation®.

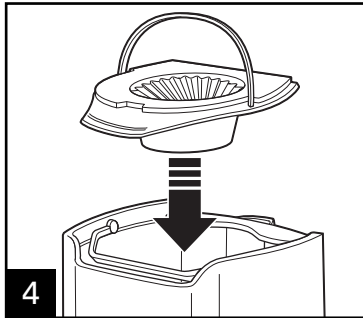

4

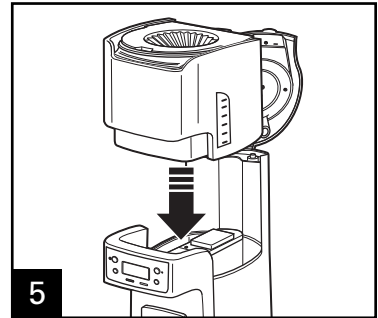

5

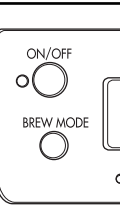

6

Set KEEP WA
4. The 0 setti

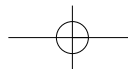

How To Make Coffee (cont.)

⚠ WARNING Burn Hazard.

- Never use coffee tank to pour or carry hot coffee.
- Handle coffee tank only when holding cold water in reservoir and to clean tank after BrewStation® when the coffee is cool.
- If BrewStation® overflows, unplug unit. Allow grounds to cool before cleaning unit, coffee, or

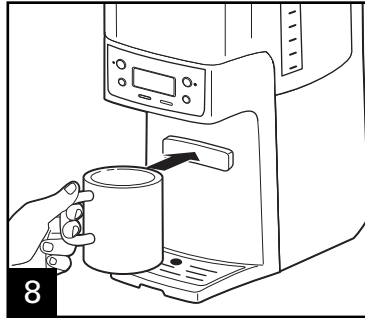
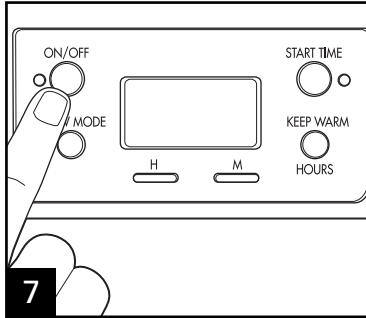

Coffeemaker will beep one time when brewing is complete.

Brew Options

BOLD

Enhanced full/strong-flavored coffee
Press Brew Mode button until **BOLD** is displayed

1-4 CUPS

When brewing 1-4 cups of coffee
Press Brew Mode button until **1-4 CUPS** is displayed

NOTE: BOLD and 1-4 CUPS modes will require a full cycle to complete a brewing cycle. A Brew Option must be selected by pressing the ON button. The setting cannot be changed while in brew mode. If a Brew Option is not selected, the coffee will automatically brew on the regular/default setting.

TO REHEAT COFFEE: Press and hold ON/OFF button for 3 seconds. This will reset the timer and keep coffee warm for 4 hours (1, 2, 3, or 4).

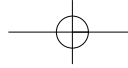

To Make Iced Coffee

*Coffee scoop is optional feature on select models.

⚠ WARNING Burn Hazard.

If BrewStation® overflows, unplug unit, coffee, and grounds before cleaning unit, coffee, or grounds.

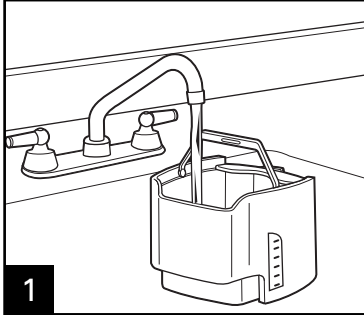

1 Fill coffee tank with water. Do not fill beyond the 6-cup line when making iced coffee.

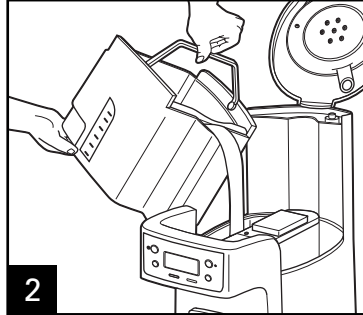

2

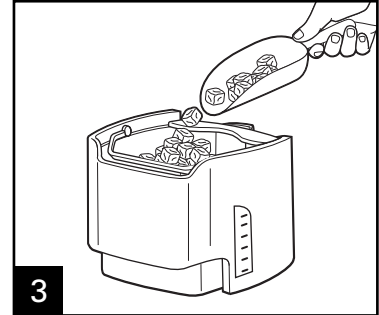

3

Fill coffee tank with ice to the **10 CUP** marking line.



4

Brew double iced coffee. 2 level table coffee per c

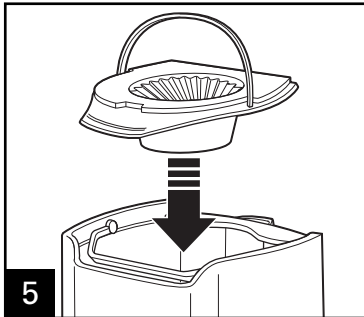

5

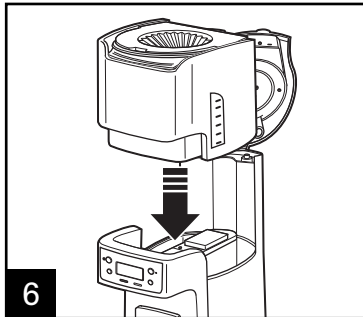

6

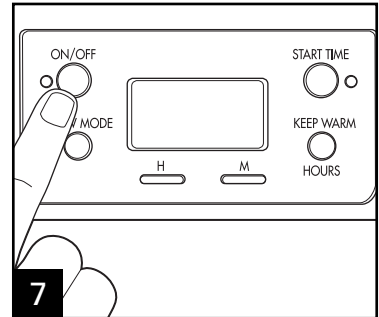

7

Set **KEEP WARM HOURS** to 0. Press **ON**.



8

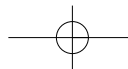

Programming

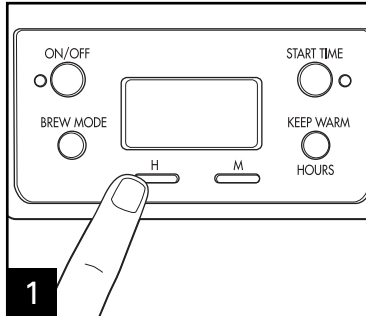

To set clock: Press **H** and then **M**.
NOTE: Clock time must be set for programming function to work.

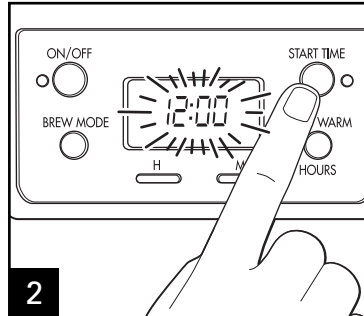

To program auto brew: Press and hold **START TIME** until clock flashes. **START TIME** will appear in display.

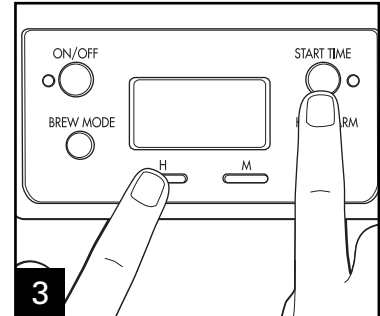

Continue holding **START TIME**; then press **H** and **M** until the desired brewing start time is reached.



Press and re-activate auto brew. A green light will be in program.

Water Filter (optional accessory)

For better tasting coffee, use a water filter. Filter replacement is recommended every 60 cycles.

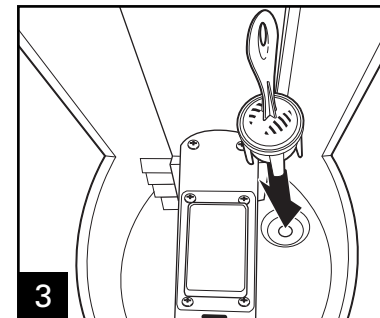
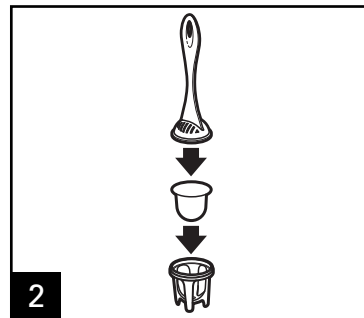
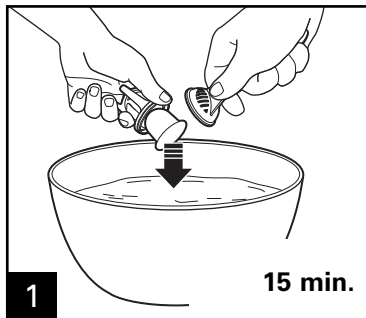

8

Water Filter

If using a water filter, it should be replaced every 60 cycles for better tasting coffee.

To Order
 1.800.
 1.800.2
 01.800.

ham
 har

Cleaning with Vinegar

Clean BrewStation® at least once a month (once a week for areas with hard water)

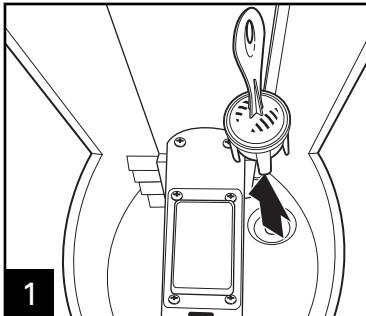

1 Remove optional water filter.

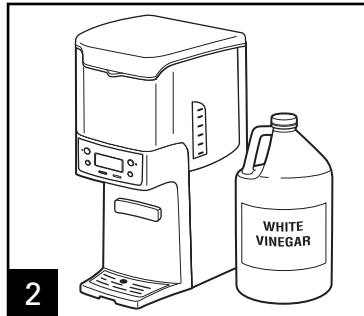

2 Pour 1 pint (2 cups/500 ml) vinegar into water reservoir.

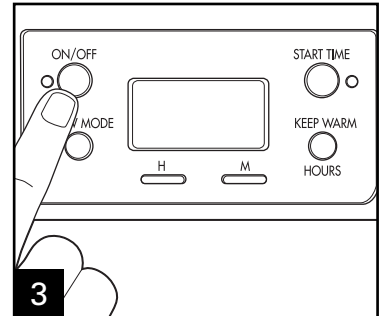

3 Press **ON**. Turn **OFF** after 20 seconds and wait 30 minutes when finished. When cool, dispense several cups before refilling reservoir. **NOTE:** Coffeemaker will remind you it is time to clean. • Built-in cycle timer—Every 30 cycles, **CLEAN** will flash in display for 2 minutes. • Built-in residue sensor—**CLEAN** will appear in display when residue buildup and remain illuminated until the unit has been cleaned.



4 Dispense several cups of coffee when cool.

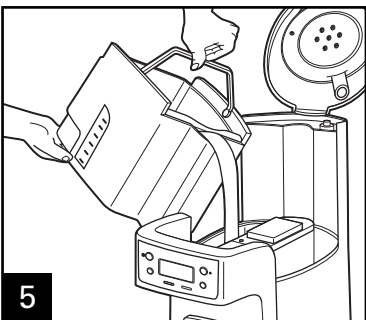

5 Run 2–3 more brew cycles with **CLEAN WATER** only. Allow to cool between cycles.



DISHWASHER-SAFE

General Cleaning Instructions

⚠ WARNING Burn Hazard. Do not immerse cord, or any liquid.

Inside of coffeemaker: Follow steps 1–5 in “Cleaning with Vinegar”.

Filter basket and coffee tank: Remove the filter basket and coffee tank. Wash by hand with warm, soapy water. Filter basket and coffee tank can be placed in the top rack of dishwasher. Clean filter basket often.

Outside of coffeemaker: Wipe outside with a soft cloth and mild detergent. Do not use abrasive cleaners, as they will scratch the product.

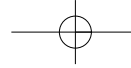

Troubleshooting

PROBLEM	PROBABLE CAUSE
Coffee leaks from dispenser.	<ul style="list-style-type: none"> • Coffee grounds trapped in coffee tank dispensing mechanism under seal in. See "Cleaning with Vinegar."
CLEAN appears in display.	<ul style="list-style-type: none"> • This is a reminder to clean coffeemaker. See "Cleaning with Vinegar."
Coffee tastes bad.	<ul style="list-style-type: none"> • Coffeemaker needs cleaning. • Coffee ground too coarsely or too finely. Set coffee grinder to automatic drip grind. • Coffee-to-water ratio unbalanced. Adjust for personal preference. • Poor water quality. Use water filter or bottled water to make coffee.
Coffee not brewing or stops brewing/unit will not turn on.	<ul style="list-style-type: none"> • Mineral deposits have built up. Clean the coffeemaker following "Cleaning with Vinegar." • Water reservoir is empty. • Unit is unplugged. • Power outage or power surge. If surge, unplug; then plug back in.
Coffee brews slowly.	<ul style="list-style-type: none"> • Coffeemaker needs cleaning. Clean at least every 30 days to maintain proper performance. • Coffeemaker is in the 1-4 CUPS or BOLD modes. Press Brew Mode button until the display shows 1-4 CUPS or BOLD.
Coffee overflows basket.	<ul style="list-style-type: none"> • Excessive amounts of coffee grounds. See Table on page 5. • Coffee ground too finely. Set coffee grinder to automatic drip grind. • More than one paper filter in filter basket. Poor quality paper filter or wrong size.
Unit beeps continuously/ will not brew and/or POUR WATER appears in display.	<ul style="list-style-type: none"> • No water in reservoir. Transfer water from coffee tank to reservoir.
Coffee is cold when dispensed.	<ul style="list-style-type: none"> • Selected Keep Warm Hours have elapsed and coffeemaker has automatically stopped brewing. See "To Reheat Coffee" instructions on page 6, or brew new cycle.

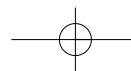

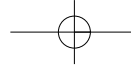

Limited Warranty

This warranty applies to products purchased in the U.S. and Canada. This is the only express warranty for this product and any other warranty or condition.

This product is warranted to be free from defects in material and workmanship for a period of one (1) year from the purchase. During this period, your exclusive remedy is repair or replacement of this product or any component found to be defective at our option; however, you are responsible for all costs associated with returning the product to us and our return shipping charges for a component under this warranty to you. If the product or component is no longer available, we will replace with a similar or greater value.

This warranty does not cover glass, filters, wear from normal use, use not in conformity with the printed directions, or damage to the product resulting from accident, alteration, abuse or misuse. This warranty extends only to the original consumer product recipient. Keep the original sales receipt, as proof of purchase is required to make a warranty claim. This warranty is intended for use for other than single-family household use.

We exclude all claims for special, incidental and consequential damages caused by breach of express or implied warranty. The amount of any award is limited to the amount of the purchase price. **Every implied warranty, including any statutory warranty or condition of sale, or fitness for a particular purpose, is disclaimed except to the extent prohibited by law, in which case such warranty shall be limited to the duration of this written warranty.** This warranty gives you specific legal rights. You may have other rights that vary depending on where you live. Some states or provinces do not allow limitations on implied warranties or special, incidental or consequential damages, so the foregoing limitations may not apply to you.

To make a warranty claim, do not return this appliance to the store. Please call 1.800.851.8900 in the U.S. or 1.800.235.8900 in Canada or visit hamiltonbeach.com in the U.S. or hamiltonbeach.ca in Canada. For faster service, locate the model, type, and serial number on your appliance.

