

ac

4/3/00

Hamilton Beach.

Coffeemaker

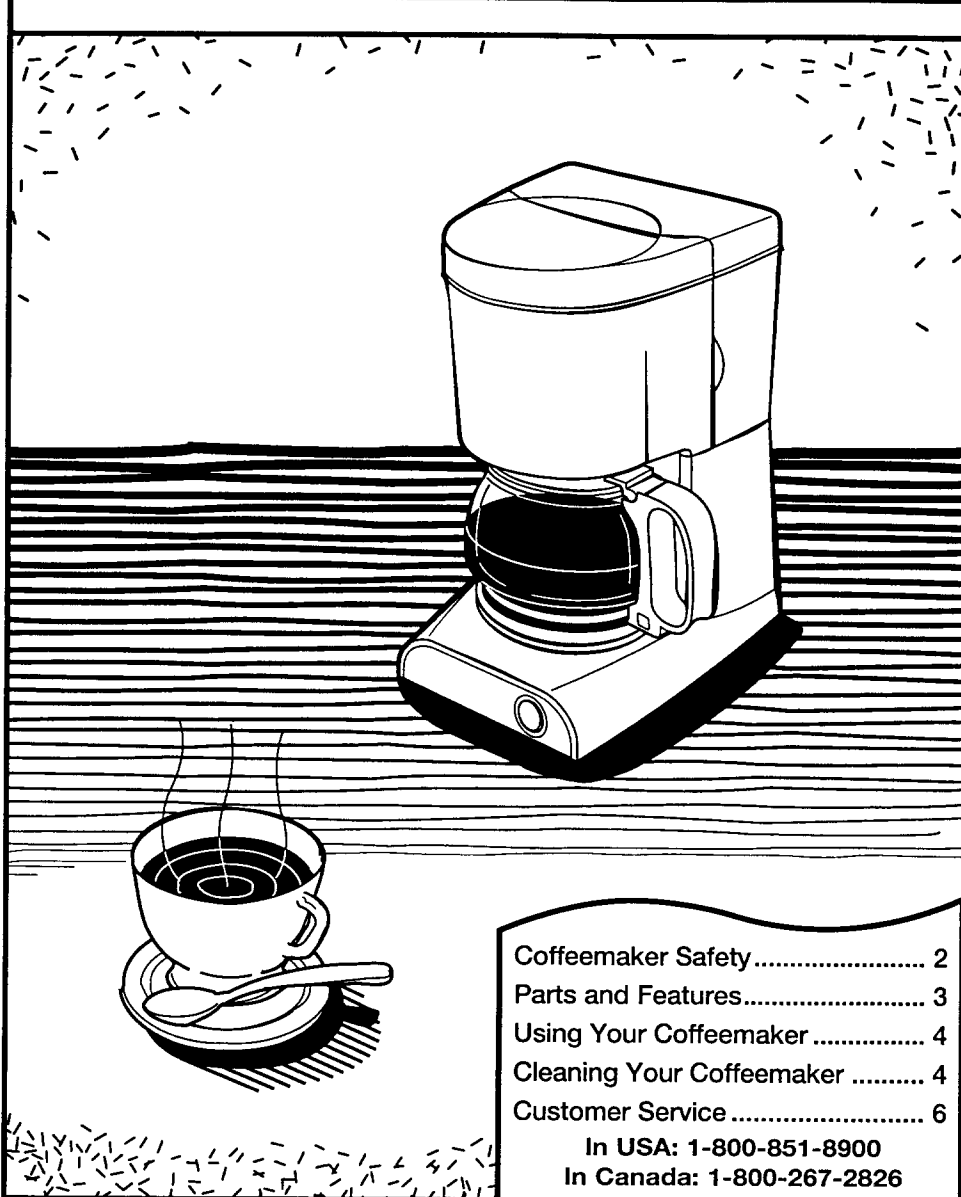

Coffeemaker Safety	2
Parts and Features	3
Using Your Coffeemaker	4
Cleaning Your Coffeemaker	4
Customer Service	6

In USA: 1-800-851-8900
 In Canada: 1-800-267-2826

5 1/2" x 8 1/2"
 12 PAGES
 ENGLISH
 FRENCH
 BLACK
 INK
 NO BLEEDS
 SADDLE
 FLIP

840069400

RECORD PRINT™
Issued On:

APR 04 2000

Coffemaker Safety

IMPORTANT SAFEGUARDS

When using electrical appliances, basic safety precautions should always be followed to reduce the risk of fire, electric shock, and/or injury to persons, including the following:

1. Read all instructions.
2. Do not touch hot surfaces. Use handles or knobs. Care must be taken, as burns can occur from touching hot parts or from spilled, hot liquid.
3. To protect against electric shock, do not place cord, plug or coffemaker in water or other liquid.
4. Close supervision is necessary when any appliance is used by or near children.
5. Unplug from outlet when the coffemaker is not in use and before cleaning. Allow to cool before putting on or taking off parts and before cleaning the appliance.
6. Coffemaker must be operated on a flat surface away from the edge of counter to prevent accidental tipping.
7. Do not operate any appliance with a damaged cord or plug, or after the appliance malfunctions or is dropped or damaged in any manner. Call our toll-free customer service number for information on examination, electrical repair, mechanical repair, or adjustment.
8. Do not let cord hang over edge of table or counter or touch hot surfaces, including stove.
9. The use of accessory attachments not recommended by Hamilton Beach/Proctor-Silex, Inc. may result in fire, electrical shock or personal injury.
10. Do not use outdoors.
11. The carafe is designed for use with this coffemaker. It must never be used on a range top or in a microwave oven.
12. Do not set a hot carafe on a wet or cold surface.
13. Do not use a cracked carafe or one with a loose or weakened handle.
14. Do not clean carafe with cleansers, steel wool pads, or other abrasive material.
15. Be certain carafe lid is securely in place during brew cycle and when pouring coffee. Do not use force when placing lid on carafe.
16. Do not place coffemaker on or near a hot gas or electric burner or in a heated oven.
17. To disconnect coffemaker, turn controls to OFF, then remove plug from wall outlet.
18. Warning: To reduce the risk of fire or electric shock, do not remove the bottom cover. No user serviceable parts are inside. Repair should be done by authorized service personnel only.
19. Do not use appliance for other than intended use.

SAVE THESE INSTRUCTIONS!

Consumer Safety Information

This appliance is intended for household use only.

This appliance is equipped with a polarized plug. This type of plug has one blade wider than the other. The plug will fit into an electrical outlet only one way. This is a safety feature intended to help reduce the risk of electrical shock. If you are unable to insert the plug into the outlet, try reversing the plug. If the plug should still fail to fit, contact a qualified electrician to replace the obsolete outlet. Do not attempt to defeat

the safety purpose of the polarized plug by modifying the plug in any way.

The length of the cord used on this appliance was selected to reduce the hazards of becoming tangled in, or tripping over a longer cord. If a longer cord is necessary an approved extension cord may be used. The electrical rating of the extension cord must be equal to or greater than the rating of the coffemaker. Care must be taken to arrange the extension cord so that it will not drape over the countertop or tabletop where it can be pulled on by children or accidentally tripped over.

Parts and Features

1. Reservoir
2. Carafe
3. Keep Hot Plate
4. Swing Open/Removable Filter Basket
5. ON/OFF Switch

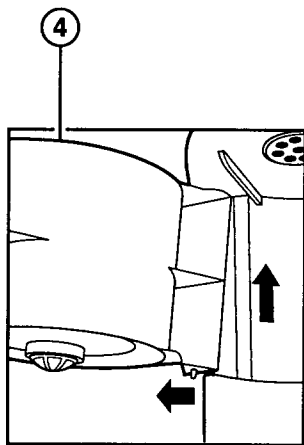

Swing Open/Removable Filter Basket

To remove, swing open then lift up. Tilt out bottom then pull down.

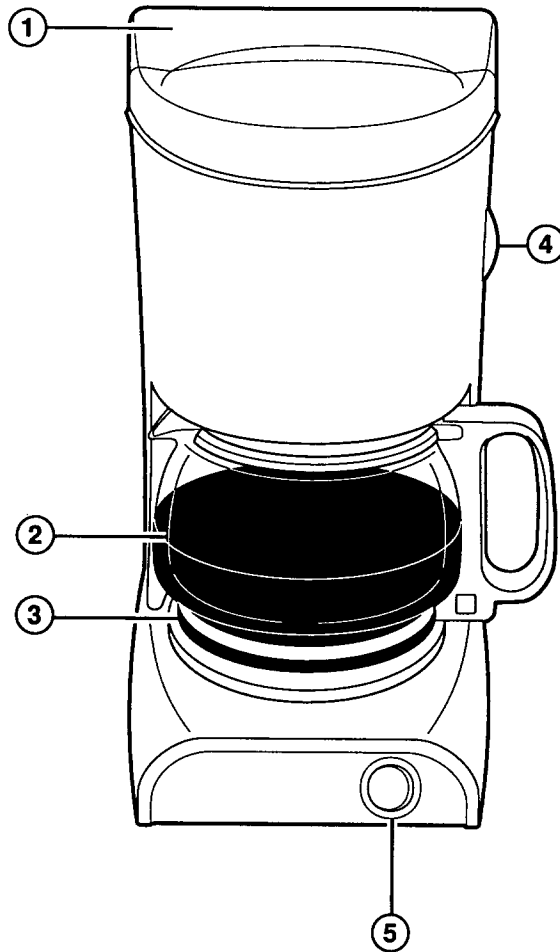

Using Your Coffeemaker

BEFORE FIRST USE: Clean coffeemaker by following steps listed in "To Clean the Inside of the Coffeemaker." Use either clear water or vinegar.

To Make Coffee

1. Place 4-cup, basket or cupcake-style disposable paper or permanent filter in filter basket.
2. For each cup of coffee being made, place one measure tablespoon of coffee into filter; close filter basket. Make sure it is fully closed.
3. Fill carafe with the desired amount of cold tap water. Carafe holds five 5-ounce cups when filled to the bottom of spout.
4. Pour water from carafe into reservoir. Do not fill above Max Fill Line in reservoir.
5. Place carafe, with carafe lid attached, on Keep-Hot Plate.
6. Turn switch ON. Turn OFF and unplug when finished.

Optional Features (on selected models)

Pause 'N Serve

This feature allows you to pour a cup of coffee before the entire brew cycle has completed. By removing the carafe, the flow of coffee will temporarily stop. The flow of coffee will resume when carafe is returned to the Keep-Hot Plate. Do not remove carafe for more than 20 seconds or brew basket may overflow.

Permanent Filter

The Permanent Filter takes the place of disposable paper filters. Simply place the Permanent Filter in the filter basket. Please rinse the Permanent Filter in hot water before first use. Clean Permanent Filter under hot running water and let dry. Permanent Filter can be placed in top rack of automatic dishwasher.

Cleaning Your Coffeemaker

To Clean the Inside of the Coffeemaker

1. Place empty carafe on Keep-Hot Plate. Swing empty filter basket closed.
2. Pour one pint of plain white vinegar into the reservoir.
3. Plug unit into electrical outlet and turn ON.
4. After 30 seconds turn OFF.
5. Wait 30 minutes to allow the vinegar to clean. Then turn ON again. When the brew cycle is finished, turn OFF.
6. Empty carafe and rinse. Pour one carafe of cold tap water into the reservoir. Place carafe on Keep-Hot Plate.
7. Turn ON. When the brew cycle is finished, empty the carafe. Repeat this process with one more carafe of cold tap water.
8. Turn OFF when complete.
9. Wash carafe and filter basket before making a beverage.

To Clean the Carafe and Filter Basket

Wash by hand in hot, soapy water or in top rack of dishwasher. To remove carafe lid, push the hinge part of the lid to one side then gently but firmly twist the lid. The pin will release from the hinge.

To replace the lid, put one side of the lid hinge on one of the pins, then snap onto the other pin.

Carafe Safety Precautions



This symbol alerts you to the potential danger for personal injury if you fail to read and follow these safety precautions.



This symbol reminds you that glass is fragile and can break which could result in personal injury.

- Do not use a cracked carafe or a carafe having a loose or weakened handle.
- This carafe is designed to be used only on the Keep-Hot plate of your coffee-maker. Do not use on a gas or electric rangetop, or in a microwave or conventional oven.
- To avoid breakage, handle carafe with care. Avoid impact. Glass will break as a result of impact. Use care when filling with water to avoid hitting faucet.
- Do not place hot carafe on cool or wet surface. Allow to cool before washing or adding liquids.
- Do not set empty carafe on a hot heating surface.
- Do not clean with steel wool pads, abrasive cleanser or any other materials that may scratch.
- Do not place hands inside carafe. When handling, be careful if wearing any hand jewelry, especially diamond rings. Jewelry can scratch the glass, which increases the possibility of breakage.
- Do not bump, scratch, or boil dry.
- Discard carafe if it is cracked, scratched, or heated while empty for an extended period of time.
- To avoid accidents, do not pour in the direction of people.
- If stirring in the carafe, use only wooden, plastic, or rubber utensils. Do not use metal utensils.
- Follow the above safety precautions carefully to avoid serious burn injuries which may result if breakage occurs while carafe holds heated liquids.

Customer Service

If you have a question about your coffeemaker, call our toll-free customer service number. Before calling, please note the model, type, and series numbers and fill in that information below. These numbers can be found on the bottom of your coffeemaker. This information will help us answer your question much more quickly.

MODEL: _____ **TYPE:** _____ **SERIES:** _____

TWO YEAR LIMITED WARRANTY

Hamilton Beach/Proctor-Silex, Inc. warrants this appliance to be free from defects in material and workmanship for a period of two (2) years from the date of original purchase, except as noted. There is no warranty with respect to the following, which may be supplied with this appliance: glass parts, glass containers, cutter/strainer, blades and/or agitators. This warranty extends only to the original consumer purchaser and does not cover damage from abuse, neglect, use for commercial purposes, or any other use not found in the printed directions. HAMILTON BEACH/PROCTOR-SILEX, INC. EXPRESSLY DISCLAIMS ALL RESPONSIBILITY FOR CONSEQUENTIAL DAMAGES OR INCIDENTAL LOSSES CAUSED BY USE OF THIS APPLIANCE. Some states or provinces do not allow this exclusion or limitation of incidental or consequential losses, so the foregoing disclaimer may not apply to you. If you have a claim under this warranty, **DO NOT RETURN THE APPLIANCE TO THE STORE!** Please call our CUSTOMER SERVICE NUMBER. (For faster service please have model, series, and type numbers ready for operator to assist you.)

CUSTOMER SERVICE NUMBERS

In the U.S. 1-800-851-8900

In Canada 1-800-267-2826

Web site address: www.hamiltonbeach.com

KEEP THESE NUMBERS FOR FUTURE REFERENCE!

This warranty gives you specific legal rights, and you may also have other legal rights which vary from state to state, or province to province.

HAMILTON BEACH ♦ PROCTOR-SILEX, INC.

263 Yadkin Road
Southern Pines, NC 28387

PROCTOR-SILEX CANADA, INC.

Picton, Ontario K0K 2T0

840069400

Web site address: www.hamiltonbeach.com

3/00