

This Owner's Manual is provided and hosted by [Appliance Factory Parts](#).



LG 40311 Owner's Manual

[Shop genuine replacement parts for LG 40311](#)



[Find Your LG Washer Parts - Select From 393 Models](#)

----- Manual continues below -----



<http://www.managemyhome.com>

WASHING MACHINE SERVICE MANUAL

▲ CAUTION

READ THIS MANUAL CAREFULLY TO DIAGNOSE
PROBLEMS CORRECTLY BEFORE SERVICING THE UNIT.

MODEL : 796.4001#9##, 4027#9##, 4031#9##



P/No.: MFL30599139

CONTENTS

1. SPECIFICATIONS	3
2. FEATURES & TECHNICAL EXPLANATION	4
3. PARTS IDENTIFICATION	7
4. INSTALLATION AND TEST	8
5. OPERATION	11
5-1. CONTROL PANEL FEATURES	11
5-2. CYCLE GUIDE	14
5-3. SPECIAL FUNCTIONS	17
5-4. EXPLANATION OF EACH PROCESS	18
6. PROGRAM CHART	20
7. TEST MODE	21
7-1. SAFETY CAUTION	21
7-2. LOAD TEST MODE	21
7-3. HOW TO CHECK THE WATER LEVEL FREQUENCY	21
8. TROUBLESHOOTING	22
8-1. SAFETY CAUTION	22
8-2. ERROR MODE SUMMARY	22
8-3. TROUBLESHOOTING SUMMARY	24
8-4. TROUBLESHOOTING WITH ERROR	26
8-5. TROUBLESHOOTING ELSE	33
9. COMPONENT TESTING INFORMATION	38
9-1. FILTER ASSEMBLY (LINE FILTER)	38
9-2. DOOR LOCK SWITCH ASSEMBLY	39
9-3. STATOR ASSEMBLY	41
9-4. PUMP MOTOR ASSEMBLY	44
9-5. INLET VALVE ASSEMBLY	45
9-6. HEATER ASSEMBLY	46
9-7. THERMISTOR ASSEMBLY	47
10. DISASSEMBLY INSTRUCTIONS	48
11. EXPLODED VIEW	57
11-1. CABINET AND CONTROL PANEL ASSEMBLY	57
11-2. DRUM AND TUB ASSEMBLY	58
11-3. DISPENSER ASSEMBLY	59

1. SPECIFICATIONS

ITEM		4002#9##	4027#9##	4031#9##
COLOR		WHITE		WHITE, PATINA BEIGE
POWER SUPPLY		AC 120 V, 60 Hz		
PRODUCT WEIGHT		179 lbs (81kg)	183 lbs (83kg)	185.2 lbs (84kg)
ELECTRIC POWER CONSUMPTION	WASHING	280 W		
	DRAIN MOTOR	50 W		
	WASH HEATER	1000W		
REVOLUTION SPEED	WASH	46 rpm		
	SPIN	0-1150 rpm		
CYCLE		8		10
WASH/RINSE TEMPERATURES		5		
SPIN SPEEDS		5		
OPTIONS		STAIN TREAT, 2 nd RINSE, AUTO SOAK DELAY START, CLEAN WASHER, CONTROL LOCK		
OPERATIONAL WATER PRESSURE		14.5-116 psi (100-800 kPa)		
CONTROL TYPE		Electronic		
WASH CAPACITY [cu.ft]		3.16 (3.6 IEC)	3.52 (4.0 IEC)	3.63 (4.2 IEC)
DIMENSIONS		27"(W) X 29 ^{3/4} "(D) X 38 ^{11/16} "(H), 51 ^{1/16} " (D, door open)		
DELAY START		up to 19 hours		
DOOR SWITCH TYPE		PTC + Solenoid		
WATER LEVEL		10 steps (by sensor)		
LAUNDRY LOAD SENSING		Incorporated		
ERROR DIAGNOSIS		Incorporated		
AUTO POWER OFF		Incorporated		
CONTROL LOCK		Incorporated		

2. FEATURES & TECHNICAL EXPLANATION

2-1. FEATURES



■ Ultra Capacity

The Larger drum enables not just higher head drop and stronger centrifugal force, but also less tangling and wrinkling of the laundry. Heavier loads, such as king size comforters, blankets, and curtains, can be washed.



■ Direct Drive System

The advanced Brushless DC motor directly drives the drum without belt and pulley.

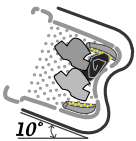

■ Tilted Drum and Extra Large Door Opening

Tilted drum and extra large opening make it possible to load and unload clothing more easily.

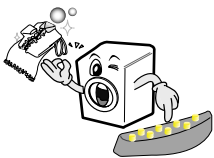

■ RollerJets

Washing ball enhances the wash performance and reduces damage to the clothing. The jets spray and help tumble clothes to enhance washing performance while maintaining fabric care.

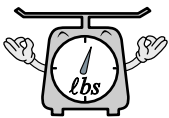

■ Automatic Wash Load Detection

Automatically detects the load and optimizes the washing time.



■ Built-in Heater

Internal heater helps to maintain water temperature at its optimum level for selected cycles.



■ Control Lock

The Control lock prevents children from pressing any button to change the settings during operation.

2-2. NEURO FUZZY WASHING TIME OPTIMIZATION

To get the best washing performance, optimal time is determined by the water temperature, the selected washing temperature, and the size of the load.

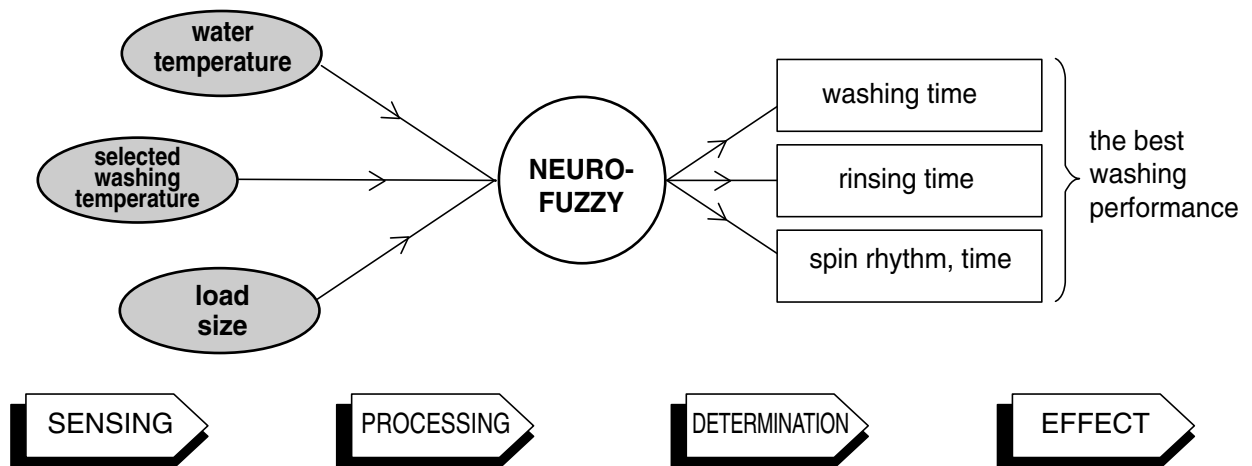

2-3. WATER LEVEL CONTROL

- This model incorporates a pressure sensor which can sense the water level in the tub.
- The water supply is stopped when the water level reaches the preset level, the washing program then proceeds.
- Spinning does not proceed until the water in the tub drains to a certain level.

2-4. DOOR CONTROL

- The door can be opened by pulling the door handle whenever washer is not in operation.
- When the cycle is completed, the DOOR LOCKED light will turn off.
- If a power failure has occurred while in operation, the door will unlock after 5 minutes.
- Clicking sounds can be heard when the door is locked/unlocked.

2-5. THE DOOR CAN NOT BE OPENED

- While program is operating.
- When a power failed and power plug is taken out in operation
- While Door Lock lights turn on.
- While the motor is in the process of inertial rotating, through the operation is paused.

2-6. CONTROL LOCK

- Use this option to prevent unwanted use of the washer. Press and hold Control Lock button for 5 seconds to lock/unlock control.
- When CONTROL LOCK is set, CONTROL LOCK lights and all buttons are disabled.
You can lock the controls of the washer while washing.

3. PARTS IDENTIFICATION

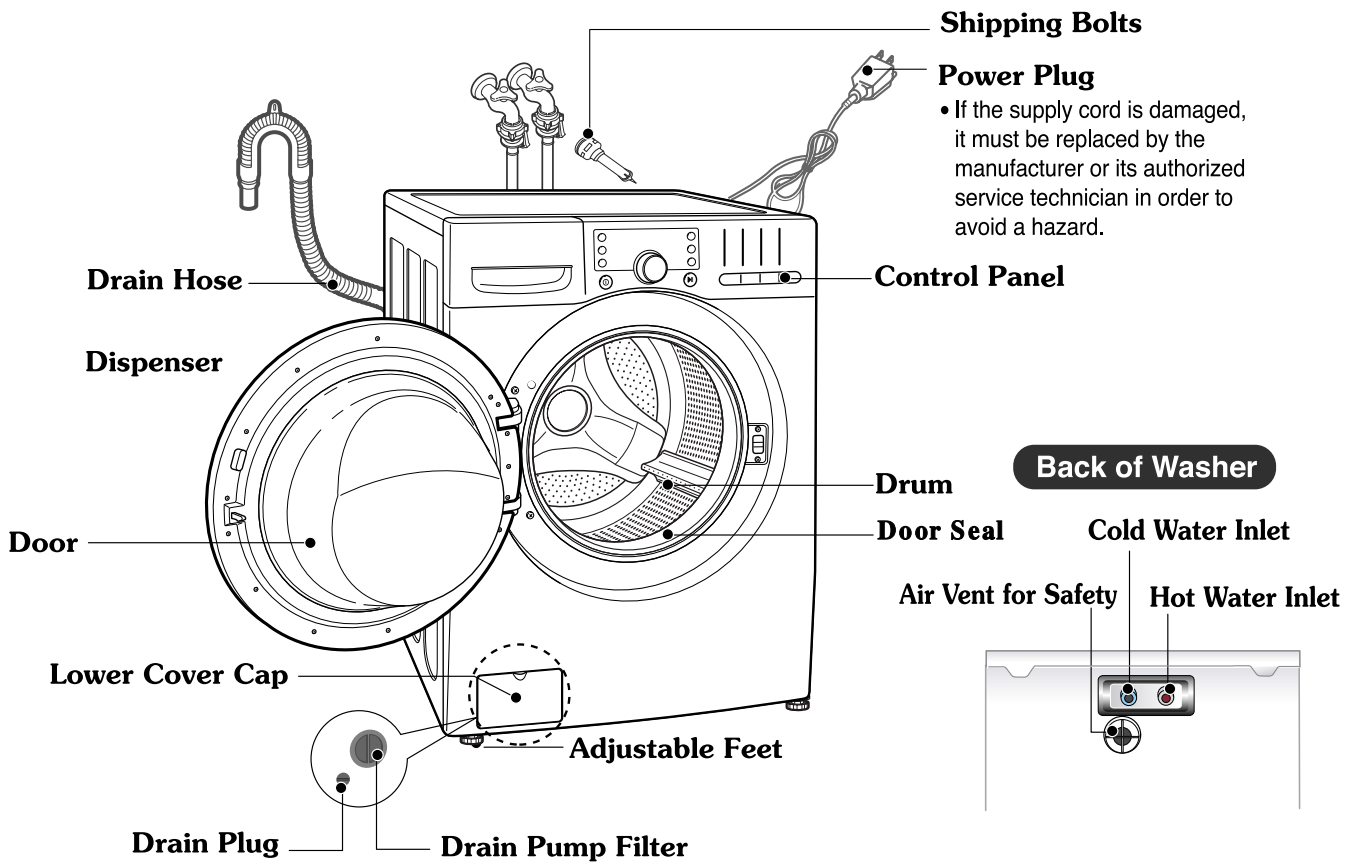

■ ACCESSORIES

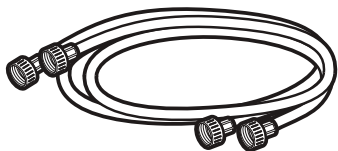

Hot/Cold (1 each) Hose

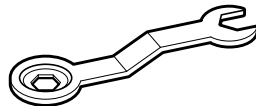

Wrench

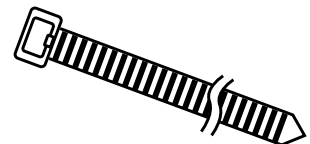

Tie strap (Option)
to secure drain hose to standpipe, inlet hose, or laundry tub

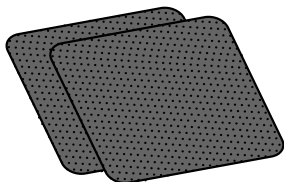

Non-skid pads



Caps(4)
(for covering shipping bolt holes)

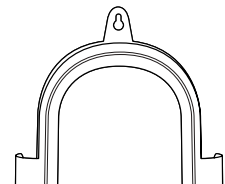

Elbow Bracket
(for securing drain hose)

4. INSTALLATION & TEST

- 1 Before servicing, ask the customer what the trouble is.
- 2 Check the setup (power supply is 120V, remove the transit bolts, level the washer...)
- 3 Check with the troubleshooting guide.
- 4 Plan your service method by referring to the disassembly instructions.
- 5 Service the unit.
- 6 After servicing, operate the appliance to see whether it functions correctly.

■ STANDARD INSTALLATION

The appliance should be installed as follows:

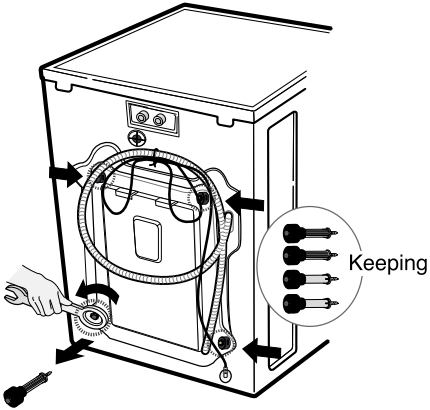
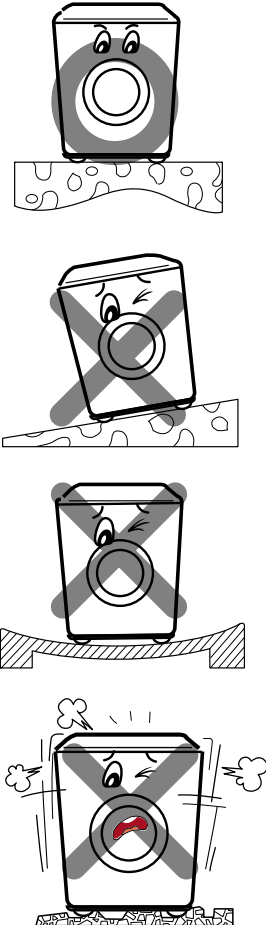
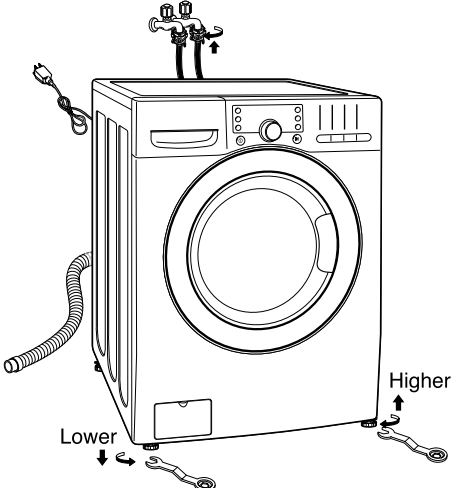
REMOVE THE SHIPPING BOLTS	INSTALL THE APPLIANCE ON A FLAT AND FIRM SURFACE	ADJUST THE LEVELING
<ul style="list-style-type: none"> • Remove the 4 shipping bolts with the supplied wrench. ※ Do first lower side to remove easily. • Keep the shipping bolts and spanner for future use. • Insert the 4 caps (provided) into the hole. 		<ul style="list-style-type: none"> • Turn the leveling feet to adjust the appliance.  <ul style="list-style-type: none"> • Turn clockwise to raise; counterclockwise to lower.

■ HOW TO CONNECT THE INLET HOSE

- Verify that the rubber washer is inside of the valve connector.
- Tighten the inlet hose securely to prevent leaks.

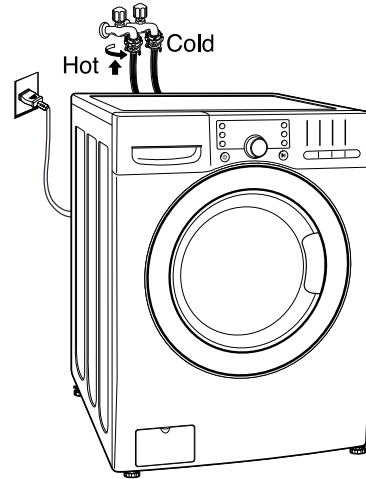

■ CONNECT THE DRAIN HOSE

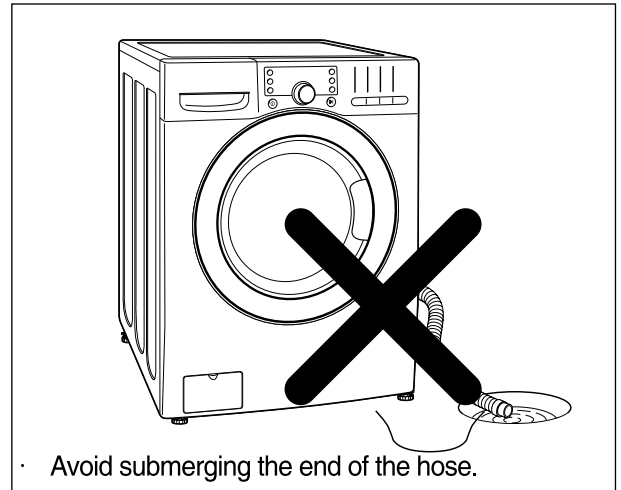
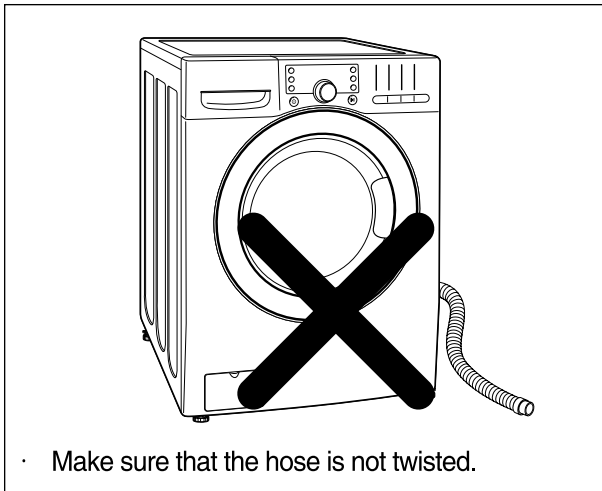

※ The end of the drain hose should be placed less than 96" from the floor.

■ CONNECT POWER PLUG

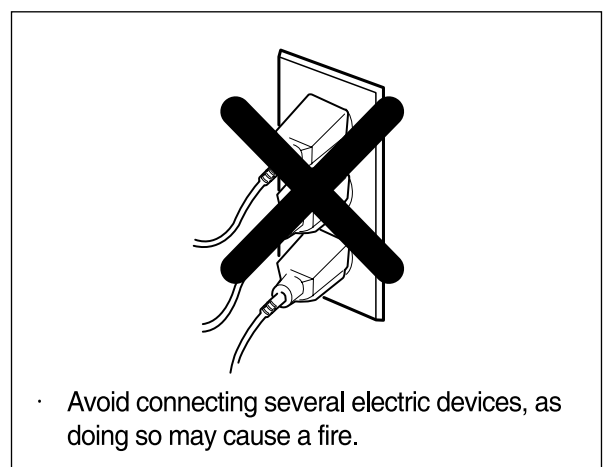
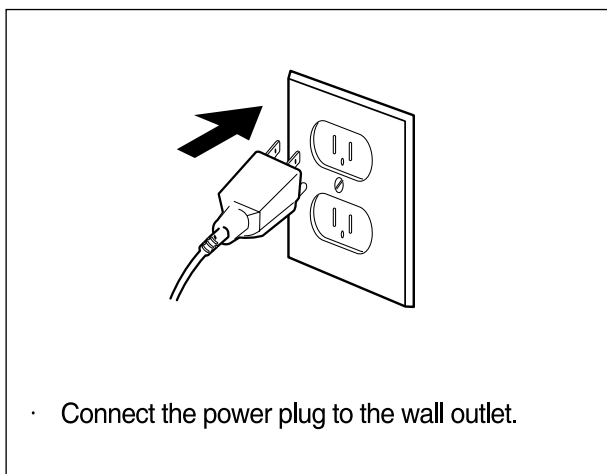

7 TEST OPERATION

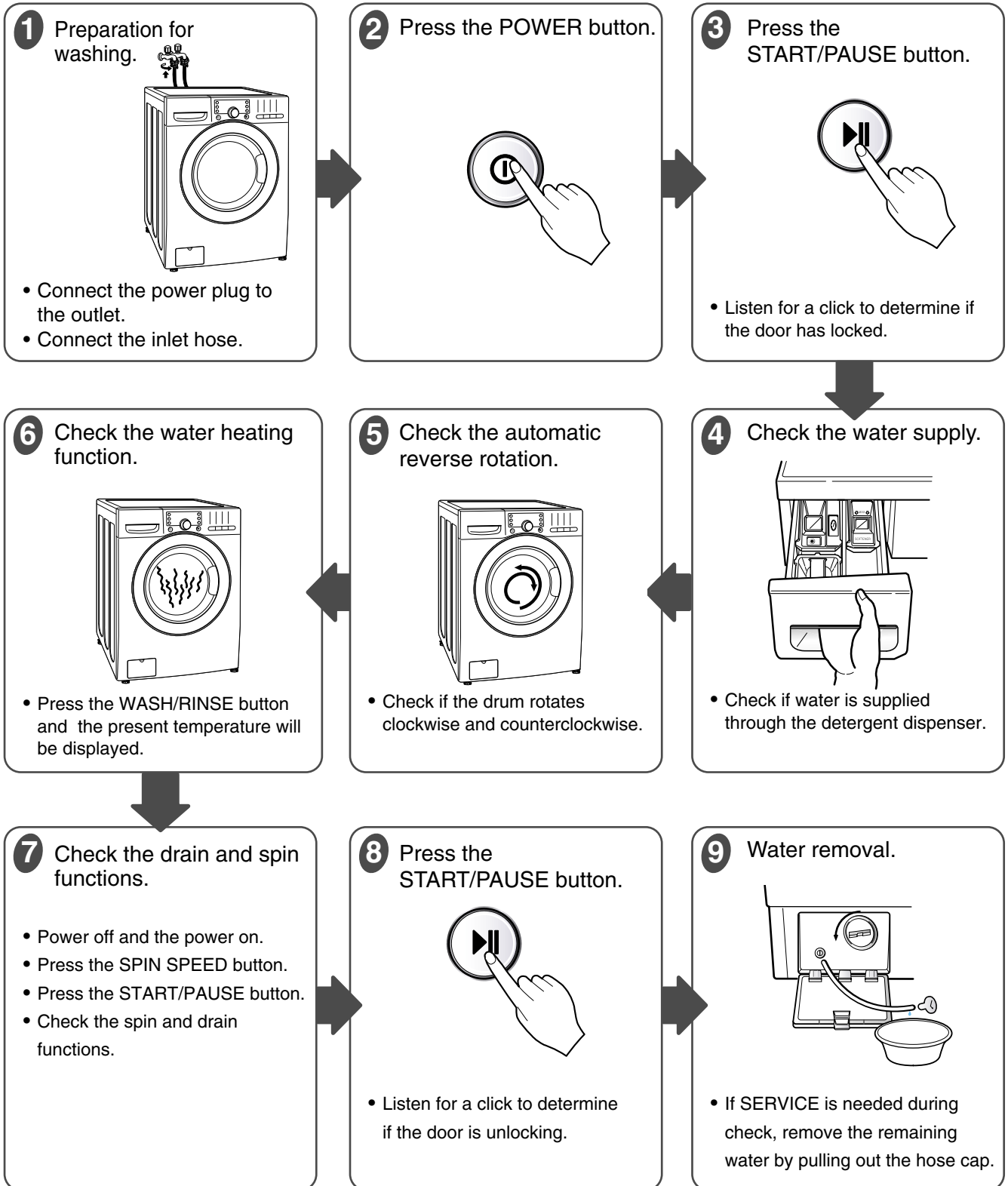

5. OPERATION

5-1. CONTROL PANEL FEATURES

■ 4002#9##, 4027#9##

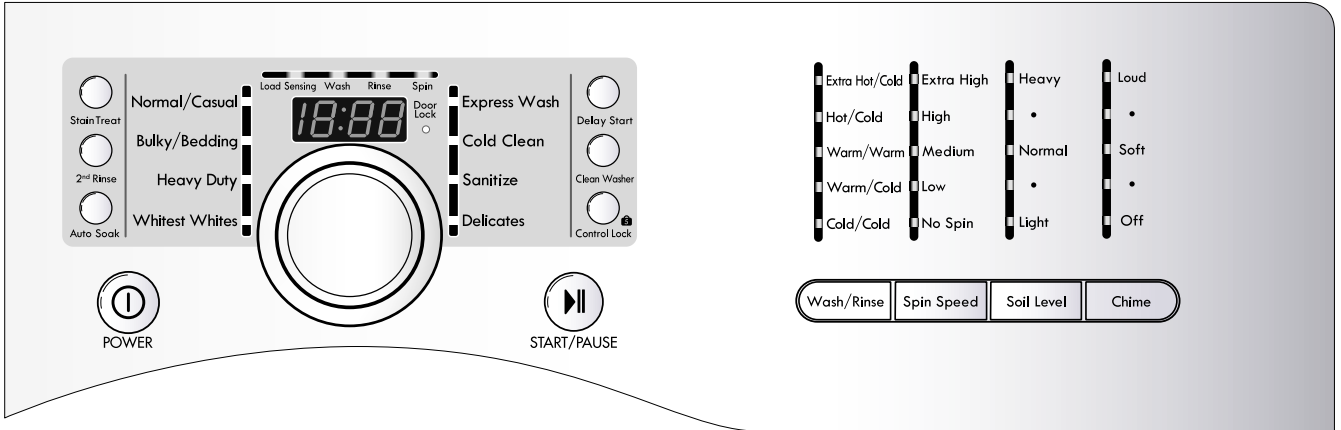

■ 4031#9##

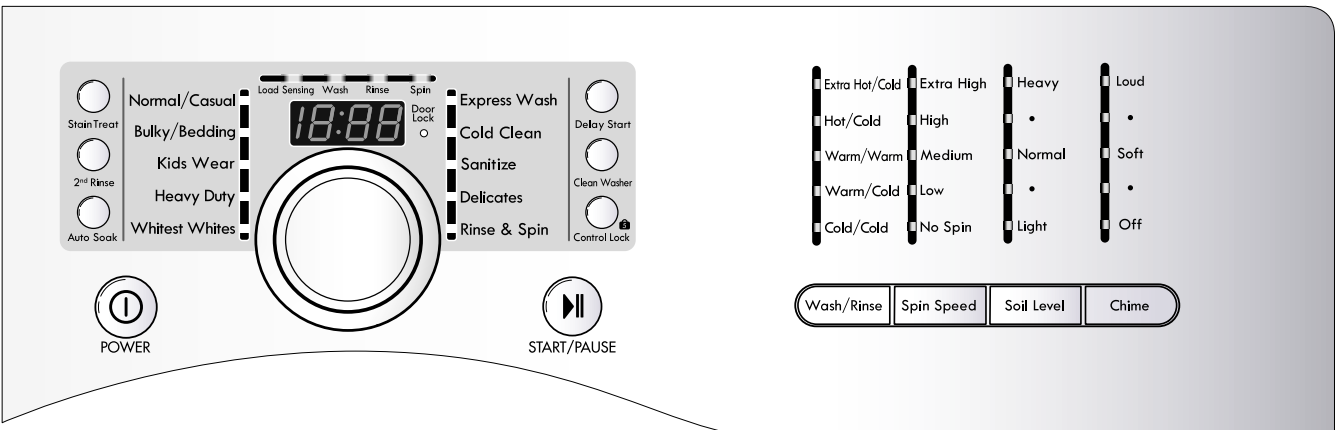

POWER BUTTON

- Use this button to turn the **POWER ON/OFF**.

STATUS INDICATOR

- It shows elapsed time of the cycle the washer is operating.

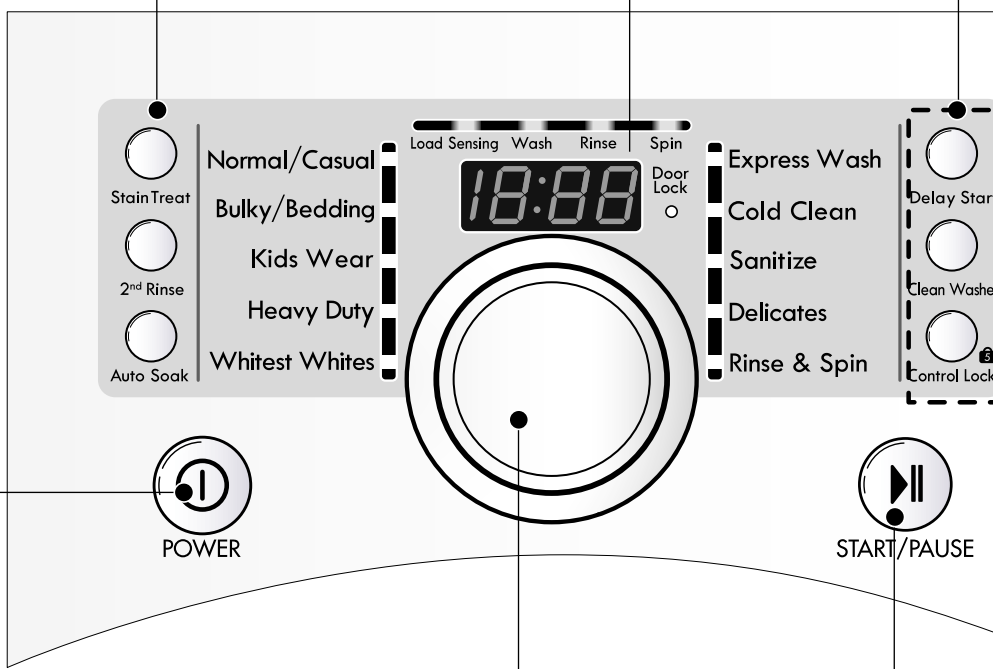

CYCLE SELECTOR KNOB

- Rotate the **CYCLE SELECTOR KNOB** to select the cycle designed for different types of fabric and soil levels.

START/PAUSE

- Use this button to **START/STOP** the washer.

The cycles may differ depending on the models.

OPTION BUTTON

- **STAIN TREAT:** Use this option for heavily soiled loads that need improved stain treatment.
- **2nd RINSE:** Use this option to add an extra rinse to the selected cycle.
- **AUTO SOAK:** Use this option to remove small spots or stains on fabrics.
- **DELAY START:** Use this option to delay the start of the wash cycle. Each press of the button increases the delay time by one hour, for up to 19 hours.
- **CLEAN WASH:** Use this option to lead to a mildew or musty smell on the washer.
- **CONTROL LOCK:** Use this option to prevent children from changing cycles or operating the machine.

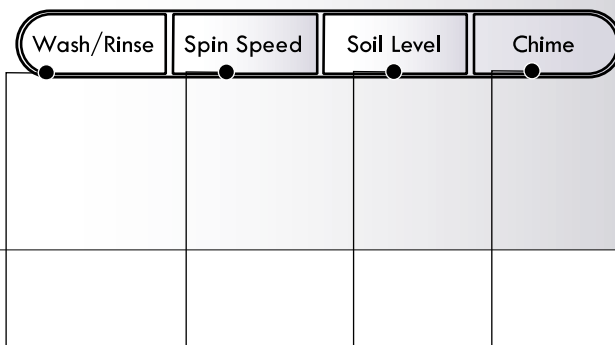
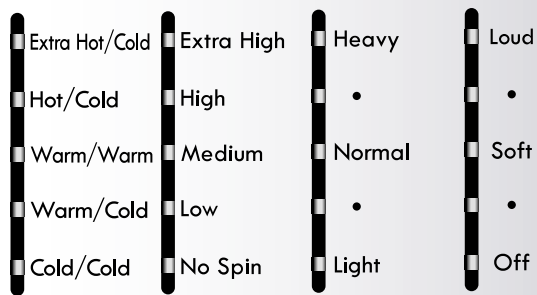

WASH/RINSE, SPIN SPEED, SOIL LEVEL, CHIME

- Select a water temperature based on the type of load you are washing.
- To change the spin speed, press the Spin Speed button repeatedly to cycle through available options.
- To change the soil level, press the Soil Level button repeatedly until the desired setting is on.
- Press repeatedly to adjust the volume of the Chime

5-2. CYCLE GUIDE

The cycle guide below shows the default settings, available options and recommended fabric types for each cycle. Allowable modifier adjustments are shown below the default setting for each cycle.

● = Available option

■ = Default setting

■ 4002#9##

Cycle			Modifiers			Options		
Cycle	Fabric or Load Type	Display Time (Min.)	Wash/Rinse Temperature	Spin Speed	Soil Level	AUTO SOAK	2 nd RINSE	STAIN TREAT
Normal/Casual	Cotton, linen, towels, shirts, sheets, jeans, mixed loads	50-59	Warm/Cold	High	Normal	●	●	●
			Warm/Warm Hot/Cold Cold/Cold	Extra High No Spin Low Medium	Heavy Light			
Bulky/Bedding	Large items such as blankets and comforters	59	Warm/Cold	Low	Normal	●	●	●
			Warm/Warm Hot/Cold Cold/Cold	Medium No Spin	Heavy Light			
Heavy Duty	Heavy soiled Cotton Fabrics	74-80	Warm/Cold	Extra High	Heavy	●	●	●
			Warm/Warm Hot/Cold Cold/Cold	No Spin Low Medium High	Light Normal			
Whitest Whites	White Fabrics	69-75	Hot/Cold	High	Normal	●	●	●
			Cold/Cold Warm/Cold Warm/Warm	Extra High No Spin Low Medium	Heavy Light			
Express Wash	Lightly soiled clothing and small loads	20	Hot/Cold	Extra High	Light	●	●	●
			Cold/Cold Warm/Cold Warm/Warm	No Spin Low Medium High	Normal Heavy			
Cold Clean	Small loads of cotton, linen, towels, shirts, sheets, jeans, mixed loads	57-63	Cold/Cold	High	Normal	●	●	●
				Extra High No Spin Low Medium	Light			
Sanitize	Heavily soiled items, such as work clothes, diapers, etc.	101-107	Extra Hot/Cold	High	Normal	●	●	●
				Extra High No Spin Low Medium	Heavy Light			
Delicates	Dress shirts/blouses nylons, sheer or lacy garments	42	Cold/Cold	Medium	Normal	●	●	●
			Warm/Cold Warm/Warm	No Spin Low	Heavy Light			

NOTE: To protect your garments, not every wash/rinse temperature, spin speed, soil level, or option is available with every cycle.

5-2. CYCLE GUIDE

The cycle guide below shows the default settings, available options and recommended fabric types for each cycle. Allowable modifier adjustments are shown below the default setting for each cycle.

● = Available option

■ 4027#9##

■ = Default setting

Cycle				Modifiers			Options		
Cycle	Fabric or Load Type	Display Time (Min.)	Wash Motion	Wash/Rinse Temperature	Spin Speed	Soil Level	AUTO SOAK	2 nd RINSE	STAIN TREAT
Normal/Casual	Cotton, linen, towels, shirts, sheets, jeans, mixed loads	50-59	○	Warm/Cold	High	Normal	●	●	●
				Warm/Warm Hot/Cold Cold/Cold	Extra High No Spin Low Medium	Heavy Light			
Bulky/Bedding	Large items such as blankets and comforters	59		Warm/Cold	Low	Normal	●	●	●
				Warm/Warm Hot/Cold Cold/Cold	Medium No Spin	Heavy Light			
Heavy Duty	Heavy soiled Cotton Fabrics	74-80	○	Warm/Cold	Extra High	Heavy	●	●	●
				Warm/Warm Hot/Cold Cold/Cold	No Spin Low Medium High	Light Normal			
Whitest Whites	White Fabrics	69-75	○	Hot/Cold	High	Normal	●	●	●
				Cold/Cold Warm/Cold Warm/Warm	Extra High No Spin Low Medium	Heavy Light			
Express Wash	Lightly soiled clothing and small loads	20		Hot/Cold	Extra High	Light		●	
				Cold/Cold Warm/Cold Warm/Warm	No Spin Low Medium High	Normal Heavy			
Cold Clean	Small loads of cotton, linen, towels, shirts, sheets, jeans, mixed loads	57-63	○	Cold/Cold	High	Normal	●	●	
					Extra High No Spin Low Medium	Light			
Sanitize	Heavily soiled items, such as work clothes, diapers, etc.	101-107		Extra Hot/Cold	High	Normal	●	●	●
					Extra High No Spin Low Medium	Heavy Light			
Delicates	Dress shirts/blouses nylons, sheer or lacy garments	42		Cold/Cold	Medium	Normal	●	●	
				Warm/Cold Warm/Warm	No Spin Low	Heavy Light			

NOTE: To protect your garments, not every wash/rinse temperature, spin speed, soil level, or option is available with every cycle.

○ **NOTE:** These cycles use various wash motions to enhance cleaning and/or fabric care performance. These wash motions may sound different at different stages of the wash cycle. This is normal.

5-2. CYCLE GUIDE

The cycle guide below shows the default settings, available options and recommended fabric types for each cycle. Allowable modifier adjustments are shown below the default setting for each cycle. ● = Available option

■ 4031#9##

■ = Default setting

Cycle				Modifiers			Options		
Cycle	Fabric or Load Type	Display Time (Min.)	Wash Motion	Wash/Rinse Temperature	Spin Speed	Soil Level	AUTO SOAK	2 nd RINSE	STAIN TREAT
Normal/ Casual	Cotton, linen, towels, shirts, sheets, jeans, mixed loads	50-59	○	Warm/Cold	High	Normal	●	●	●
				Warm/Warm Hot/Cold Cold/Cold	Extra High No Spin Low Medium	Heavy Light			
Bulky/ Bedding	Large items such as blankets and comforters	59		Warm/Cold	Low	Normal	●	●	●
				Warm/Warm Hot/Cold Cold/Cold	Medium No Spin	Heavy Light			
Kids Wear	Kids wear	91-97	○	Hot/Cold	High	Heavy	●	●	●
				Cold/Cold Warm/Cold Warm/Warm	Extra High No Spin Low Medium	Light Normal			
Heavy Duty	Heavy soiled Cotton Fabrics	74-80	○	Warm/Cold	Extra High	Heavy	●	●	●
				Warm/Warm Hot/Cold Cold/Cold	No Spin Low Medium High	Light Normal			
Whitest Whites	White Fabrics	69-75	○	Hot/Cold	High	Normal	●	●	●
				Cold/Cold Warm/Cold Warm/Warm	Extra High No Spin Low Medium	Heavy Light			
Express Wash	Lightly soiled clothing and small loads	20		Hot/Cold	Extra High	Light		●	
				Cold/Cold Warm/Cold Warm/Warm	No Spin Low Medium High	Normal Heavy			
Cold Clean	Small loads of cotton, linen, towels, shirts, sheets, jeans, mixed loads	57-63	○	Cold/Cold	High	Normal	●	●	
					Extra High No Spin Low Medium	Light			
Sanitize	Heavily soiled items, such as work clothes, diapers, etc.	101-107		Extra Hot/Cold	High	Normal	●	●	●
					Extra High No Spin Low Medium	Heavy Light			
Delicates	Dress shirts/blouses nylons, sheer or lacy garments	42		Cold/Cold	Medium	Normal	●	●	
				Warm/Cold Warm/Warm	No Spin Low	Heavy Light			
Rinse & Spin	Rinse and Spin	20			High			●	
					Extra High No Spin Low Medium				

NOTE: To protect your garments, not every wash/rinse temperature, spin speed, soil level, or option is available with every cycle.

○ **NOTE:** These cycles use various wash motions to enhance cleaning and/or fabric care performance. These wash motions may sound different at different stages of the wash cycle. This is normal.

5-3. SPECIAL FUNCTIONS

STAIN TREAT



Stain Treat

Use this option for heavily soiled loads that need improved stain treatment. When STAIN TREAT is selected, the water temperature for the selected cycle will begin as warm water to help prevent the setting of certain types of stains. Then as the cycle progresses, the water will be heated to higher temperatures to help remove stains that require treatment at higher temperatures. This option is designed for optimum stain removal.

NOTE: If STAIN TREAT is selected with the SANITIZE cycle, the cycle will begin with very hot water since that is default for that cycle and cannot be changed.

2nd RINSE



2nd Rinse

This option will add an extra rinse to the selected cycle. Use this option to help ensure the removal of detergent or bleach residue from fabrics.

AUTO SOAK



Auto Soak

Use the AUTO SOAK option to presoak garments to help remove difficult spots or stains on fabrics. This option provides a 30 minute presoak prior to the start of the selected cycle.

- 1 Add detergent only to the Main wash compartment of the dispenser drawer.
- 2 Select desired cycle.
- 3 Select cycle modifiers.
- 4 Press the START/PAUSE.

DELAY START



Delay Start

Once you have selected the cycle and other settings, press this button to delay the start of the wash cycle. Each press of the button increases the delay time by one hour, for up to 19 hours. Once the desired delay time is set, press the START/PAUSE button to start the delay time. If the START/PAUSE button is not pressed within 4 minutes, the control will shut off and the settings will be lost.

CLEAN WASHER



Clean Washer

A buildup of detergent residue can occur in the wash tub over time and can lead to a mildewy or musty smell. The CLEAN WASHER cycle is specially designed to remove this buildup using bleach or other cleaner designed specifically for cleaning front load washers. The CLEAN WASHER cycle should be run once a month, or more often under heavy use conditions or if odor is present.

- 1 Turn on the washer and press the CLEAN WASHER button. Selecting any other cycle after CLEAN WASHER has been selected will cause the CLEAN WASHER cycle to be cancelled.
- 2 Fill the bleach dispenser to the MAX line with liquid chlorine bleach. Do not overfill the bleach dispenser. Overfilling will cause the bleach to be dispensed immediately.
- 3 Press the START/PAUSE to start the cycle.
- 4 After the cycle has ended, open the door and allow the drum interior to dry completely.

NOTE: Do NOT use this cycle with clothes, and do NOT add detergent or fabric softener.

* For powdered tub cleaners, add the cleaner to the main wash compartment of the dispenser drawer. Place tablet cleaners directly into the tub. Always follow the cleaner manufacturers instructions and recommendations

CONTROL LOCK



Control Lock

Use this option to disable the controls. This feature allows you to prevent children from changing cycles or operating the machine. Once set, the CONTROL LOCK must be turned off before the controls can be used. Once the washer has shut off, the power button will allow the machine to be turned on, but the controls will still be locked. When the controls are locked, "CL" will be displayed alternately with the estimated time remaining.

Press and hold the CONTROL LOCK button for 5 seconds to activate or deactivate the controls.

To lock the controls without running a cycle, turn the washer on then press and hold the CONTROL LOCK button for 5 seconds. The controls will be locked, and the washer will power off after 4 minutes.

5-4. EXPLANATION OF EACH PROCESS

No.	Process	Explanation
1.	Stay	<ul style="list-style-type: none"> • Electrical power is supplied • Washer is ready to work and the micom is in the active mode.
2.	Water supply	<ul style="list-style-type: none"> • After loading laundry and selecting a course and a cycle, water is supplied and drum rotates. • When a user selects Pre-wash course, water is supplied through pre wash valve.
3.	Soaking & washing laundry	<ul style="list-style-type: none"> • To get laundry wet, drum rotates clockwise and counterclockwise. • If water amount is insufficient at this time, the Inlet valve will supply water again.
4.	Heating & washing	<ul style="list-style-type: none"> • The heater heats the water in drum to the selected water temperature and drum rotates for washing.
5. ~ 6.	Washing & heating / washing	<ul style="list-style-type: none"> • When the water temperature reaches to the selected temperature, the heating stops and only the drum rotates. • If water temperature becomes lower than selected because of re-supplied water, the heating starts again.
7.	Washing	<ul style="list-style-type: none"> • Fuzzy Logic decides washing time according to the laundry load, water temperature, and other factors.
8.	Drainage	<ul style="list-style-type: none"> • A pump motor drains the water from the drum. • After sensing drained water amount by water level frequency, spin starts. • When a heating course is selected, stay cooling process is performed to decrease the water temperature gradually to prevent laundry from being damaged and for safety reasons.
9.	Untangling (Sensing eccentricity)	<ul style="list-style-type: none"> • It balances laundry load and senses the eccentricity of the load, to only allow spinning without vibration • If the eccentricity is worse than the allowed level, it repeats the disentangling process. When the repeated time is more than allowed level, it displays UE. • If the eccentricity is good, the intermittent spin starts. • During this process, the drain pump works for drainage intermittently.

No.	Process	Explanation
A.	Intermittent spin	<ul style="list-style-type: none"> To reach the correct set speed, the motor rotates clockwise and counterclockwise directions after spin process starts. If the water level frequency is lower than 23.0 kHz, a washer senses suds and starts suds removal process.
B.	Rinse spin	<ul style="list-style-type: none"> In this process, the remaining water during washing process is extracted and the selected speed is kept. Removing suds process is in active mode at this cycle.
C.	Remaining spin	<ul style="list-style-type: none"> After spin finishes, the drum rotates by remaining spin power until it stops. Motor power is off. This process is overlapped with next process.
D.	Rinse water supply	<ul style="list-style-type: none"> Water supply for rinse process
E.	Rinse	<ul style="list-style-type: none"> Rinsing process.
F.	Last drainage	<ul style="list-style-type: none"> After spin finishes and power is not supplied to motor, the drum rotates by remaining spin power If rinse hold is selected, the drainage is not proceeded after rinse finishes.
G.	Disentangling	<ul style="list-style-type: none"> The same as item 9.
H.	Intermittent spin	<ul style="list-style-type: none"> The same as item A.
I.	Main spin1	<ul style="list-style-type: none"> The same as item B.
J.	Main spin2	<ul style="list-style-type: none"> At the end of a main spin, the spin speed will reach the selected rpm.
K.	Remaining spin	<ul style="list-style-type: none"> The same with item C.
L.	Disentangling	<ul style="list-style-type: none"> After spin finishes, disentangling starts to remove unbalanced laundry.
M.	End	<ul style="list-style-type: none"> After 'end' signal is displayed, it stays for 8 seconds and power is automatically turned off. (Auto type door switch) After door switch is off, end signal is displayed in the case of manual type and it takes around 2 minute to turn off door switch.



7. TEST MODE

7-1. SAFETY CAUTION

- There's built-in AC 110V and DC power in output terminal of PWB assembly in common. Be careful electric shock when disconnecting parts while trouble shooting. (Wear Electro Static Discharge gloves when working.)
- After cutting off the power when changing PWB assembly, disconnect or assemble.
- Be careful static when handling PWB assembly, and use Electro Static Discharge plastic pack when delivering or keeping it.

7-2. LOAD TEST MODE.

The washer must be empty and the controls must be in the off state.

1. Press the SPIN SPEED and SOIL LEVEL buttons simultaneously.
2. Press the POWER  button, while the above condition. Then buzzer will sound twice.
3. Press the START/PAUSE  button repeatedly to cycle through the test modes.

Number of times the Start/Pause button is pressed	Check Point	Display Status
None	Turns on all lamps and locks the door.	LOAD TEST MODE
1 time	Tumble clockwise.	rpm (42~50)
2 times	Low speed Spin.	rpm (35~45)
3 times	High speed Spin. ※ It will be take about 2minits to be high speed spin	rpm (110~117)
4 times	Inlet valve for prewash turns on.	Water level frequency (0~255)
5 times	Inlet valve for main wash turns on.	Water level frequency (0~255)
6 times	Inlet valve for hot water turns on.	Water level frequency (0~255)
7 times	Inlet valve for bleach turns on.	Water level frequency (0~255)
8 times	Tumble counterclockwise.	rpm (42~50)
9 times	Heater turns on for 3 seconds.	Water temperature
10 times	Drain pump turns on.	Water level (0-255)
11 times	off	-

NOTES:

- RPM < 220 : RPM = display / RPM > 200 : RPM = display X 10
- WATER LEVEL : o255 = empty / o248 = normal / o255 = tub clean

7-3. HOW TO CHECK THE WATER LEVEL FREQUENCY

* Press the WASH/RINSE and DELAY START button simultaneously.

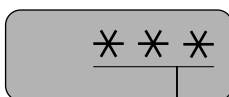

● The digits indicate the water level frequency (x.1 kHz).

So, for example a display indicating 241: a Water level frequency of 241 x.1 kHz
= 24.1 kHz

8. TROUBLESHOOTING

8-1. SAFETY CAUTION

- There's built-in AC 120V and DC power in output terminal of PWB assembly in common. Be careful electric shock when disconnecting parts while trouble shooting. (Wear Electro Static Discharge gloves when working.)
- After cutting off the power when changing PWB assembly, disconnect or assemble.
- Be careful static when handling PWB assembly, and use Electro Static Discharge plastic pack when delivering or keeping it.

8-2. ERROR MODE SUMMERY

- If you press the START/PAUSE button when an error is displayed, any error except 『PE』 will disappear and the machine will go into the pause status.
- In case of 『PE』, 『LE』, 『dE』 if the error is not resolved within 20 sec., or the in case of other errors, if the error is not resolved within 4 min., power will be turned off automatically and the error code will blink. But in the case of 『FE』, power will not be turned off.

	ERROR	SYMPTOM	CAUSE
1	WATER INLET ERROR		<ul style="list-style-type: none"> • Correct water level (246) is not reached within 8 minutes after water is supplied or it does not reach the preset water level within 25 minutes.
2	UNBALANCE ERROR		<ul style="list-style-type: none"> • The load is too small. • The appliance is tilted. • Laundry is gathered to one side. • Non distributable things are put into the drum.
3	DRAIN ERROR		<ul style="list-style-type: none"> • Not fully drained within 10 minutes.
4	OVER FLOW ERROR		<ul style="list-style-type: none"> • Water is overflowing (water level frequency is over 213). ※ If is displayed, the drain pump will operate to drain the water automatically.
5	PRESSURE SENEOR ERROR		<ul style="list-style-type: none"> • The SENSOR SWITCH ASSEMBLY is out of order.
6	DOOR OPEN ERROR		<ul style="list-style-type: none"> • Door not all the way closed. • Loose electrical connections at Door switch and PWB Assembly. • The DOOR SWITCH ASSEMBLY is out of order.
7	HEATING ERROR		<ul style="list-style-type: none"> • The THERMISTOR is out order.

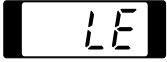
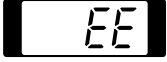
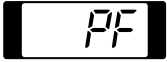
	ERROR	SYMPTOM	CAUSE
8	LOCKED MOTOR ERROR		<ul style="list-style-type: none"> • The connector (3-pin, male, white) in the MOTOR HARNESS is not connected to the connector (3-pin, female, white) of STATOR ASSEMBLY. • The electric contact between the connectors (3-pin, male, white) in the MOTOR HARNESS and 4-pin, female, white connector in the MAIN PWB ASSEMBLY is bad or unstable. • The MOTOR HARNESS between the STATOR ASSEMBLY and MAIN PWB ASSEMBLY is cut (open circuited). • The hall sensor is out of order/defective.
9	EEPROM ERROR		<ul style="list-style-type: none"> • EEPROM is out of order. ※ Displayed only when the START/PAUSE button is first pressed in the QC Test Mode.
10	POWER FAILURE		<ul style="list-style-type: none"> • The washer experienced a power failure.

8-3. TROUBLESHOOTING SUMMARY

CIRCUIT DIAGRAM

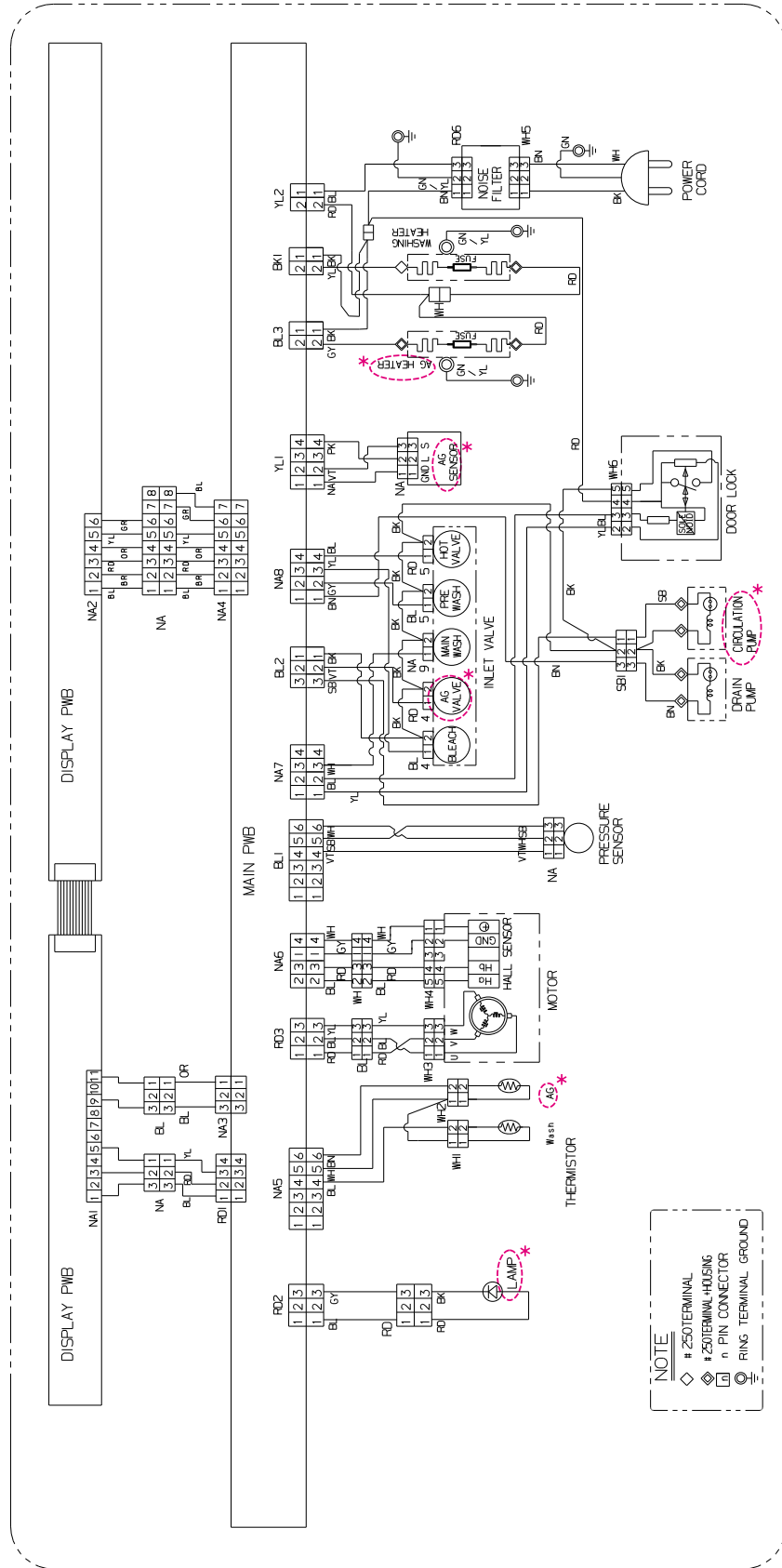

NOTE: * These are only on models with the steam feature.

COLOR KEY			
BK – Black	SB – Sky Blue	YL – Yellow	WH – White
BL – Blue	OR – Orange	GY – Gray	BN – Brown
RD – Red	GR – Green	NA – Natural	PK – Pink
VT – Violet			
NA2 DISPLAY PCB			
TEST POINTS	VALUE		
NA2-3 RD	Ground		
NA2-4 OR	12Vdc		
NA2-5 YL	5Vdc		
RD2 MAIN PCB - LAMP			
TEST POINTS	VALUE		
RD2-1 BL	16.5Vdc		
NA5 MAIN PCB - THERMISTOR			
TEST POINTS	COMPONENT		
NA5-4 BL	Wash Thermistor		
NA5-6 BN	AG Thermistor		
RD3 and NA6 MAIN PCB - MOTOR			
TEST POINTS	COMPONENT		
RD3-1 RD	U		
RD3-2 BL	V		
RD3-3 YL	W		
NA6-1 GY	+		
NA6-2 BL	Hb		
NA6-3 RD	Ha		
NA6-4 WH	GND		
NA6 MAIN PCB – MOTOR			
TEST POINTS	RESISTANCE	REMARKS	
NA6-1 GY to 2 RD	8-12 Ω		
NA6-1 GY to 3 BL	8-12 Ω		
NA6-1 GY to 4 GY	10-15 Vdc	Voltage (input)	
NA6-2 BL to 4 GY	10 Vdc	Pulsing Signal	
NA6-3 RD to 4 GY	10 Vdc	Pulsing Signal	
NA7 MAIN PCB - DOOR SWITCH			
TEST POINTS	COMPONENT		
NA7-1 YL	PTC		
NA7-2 BL	PTC		

NA7, BL2 and NA8 MAIN PCB – INLET VALVE			
TEST POINTS	COMPONENT		
NA7-3 WH	Main Wash		
BL2-1 BK	Common		
BL2-2 VT	AG Valve		
NA8-2 GY	Pre Valve		
NA8-3 YL	Bleach		
NA8-4 BL	Hot Valve		
BL2, NA8 and SB1 MAIN PCB - PUMPS			
TEST POINTS	COMPONENT	CONDITION	
BL2-3 SB	Common	Pump running	
NA8-1 BN	Drain Pump	Pump stopped	
SB1-1 SB, 2 BK	Recirc Pump*	Drain pump disconnected	
YL1 MAIN PCB – AG SENSOR			
TEST POINTS	COMPONENT		
YL1 -1 NA	Ground		
YL1 -2 VT	S		
YL1 -4 PK	L		
BL3, BK1 and YL2 MAIN PCB - HEATER			
TEST POINTS	COMPONENT	RESISTANCE	
BL3-2 GY, BK1-2 YL	Vac (input)	12 Ω - 18 Ω	
BL3-1 BK	Steam Generator/Heater (input)		
BK1-2 YL	Wash Heater (input)		
YL2-1 BL	Steam Generator/Heater (output)		
YL2-2 RD	Vac (output)		
WH1 MAIN PCB – TUB THERMISTORS			
TEST POINTS	COMPONENT	TEMPERATURE	RESISTANCE
WH1 -1 WH	Common	86°F (30°C) 104°F (40°C) 140°F (60°C)	39.5 kΩ 26.1 kΩ 12.1 kΩ
WH1 -1 WH, -2 BL	Tube Thermistor	158°F (70°C) 203°F (95°C) 221°F (105°C)	8.5 kΩ 3.8 kΩ 2.8 kΩ

WH2 MAIN PCB – STEAM THERMISTOR			
TEST POINTS	COMPONENT	TEMPERATURE	RESISTANCE
WH2 -2BN	Steam Thermistor*	86°F (30°C)	39.5 kΩ
		104°F (40°C)	26.1 kΩ
		140°F (60°C)	12.1 kΩ
		158°F (70°C)	8.5 kΩ
		203°F (95°C)	3.8 kΩ
		221°F (105°C)	2.8 kΩ
		241°F (116°C)	2.1 kΩ
		266°F (130°C)	1.4 kΩ
		293°F (145°C)	1.0 kΩ
		320°F (160°C)	0.7 kΩ
356°F (180°C)	0.4 kΩ		
WH3 MAIN PCB – MOTOR			
TEST POINTS	RESISTANCE		
WH3 -1 BL to 2 RD	5-15 Ω		
WH3 -2 RD to 3 YL	5-15 Ω		
WH3 -3 YL to 1 BL	5-15 Ω		
NA9 INLET VALVE– MAIN WASH			
TEST POINTS	RESISTANCE		
NA9 -1 WH to 2 BK	0 Ω-15 kΩ		
RD6 and WH5 POWER CORD– NOISE FILTER			
TEST POINTS	RESISTANCE		
WH5-1 BK to RD6-3 BL	0 Ω		
WH5-3 BN to RD6-1 BN	0 Ω		
WH6 MAIN PCB – DOOR LOCK			
TEST POINTS	TEMPERATURE	RESISTANCE	
WH6-2 YL to 4 RD	77°F (25°C)	700-1500 Ω	
WH6-3 BL to 4 RD	77°F (25°C)	60-90 Ω	
WH6-4 RD to 5 BK		Infinity	
WH6-2 YL to 4 RD	Voltage Input	120 Vac	

* Only on steam models

8-4. TROUBLESHOOTING WITH ERROR

INLET VALVE ERROR

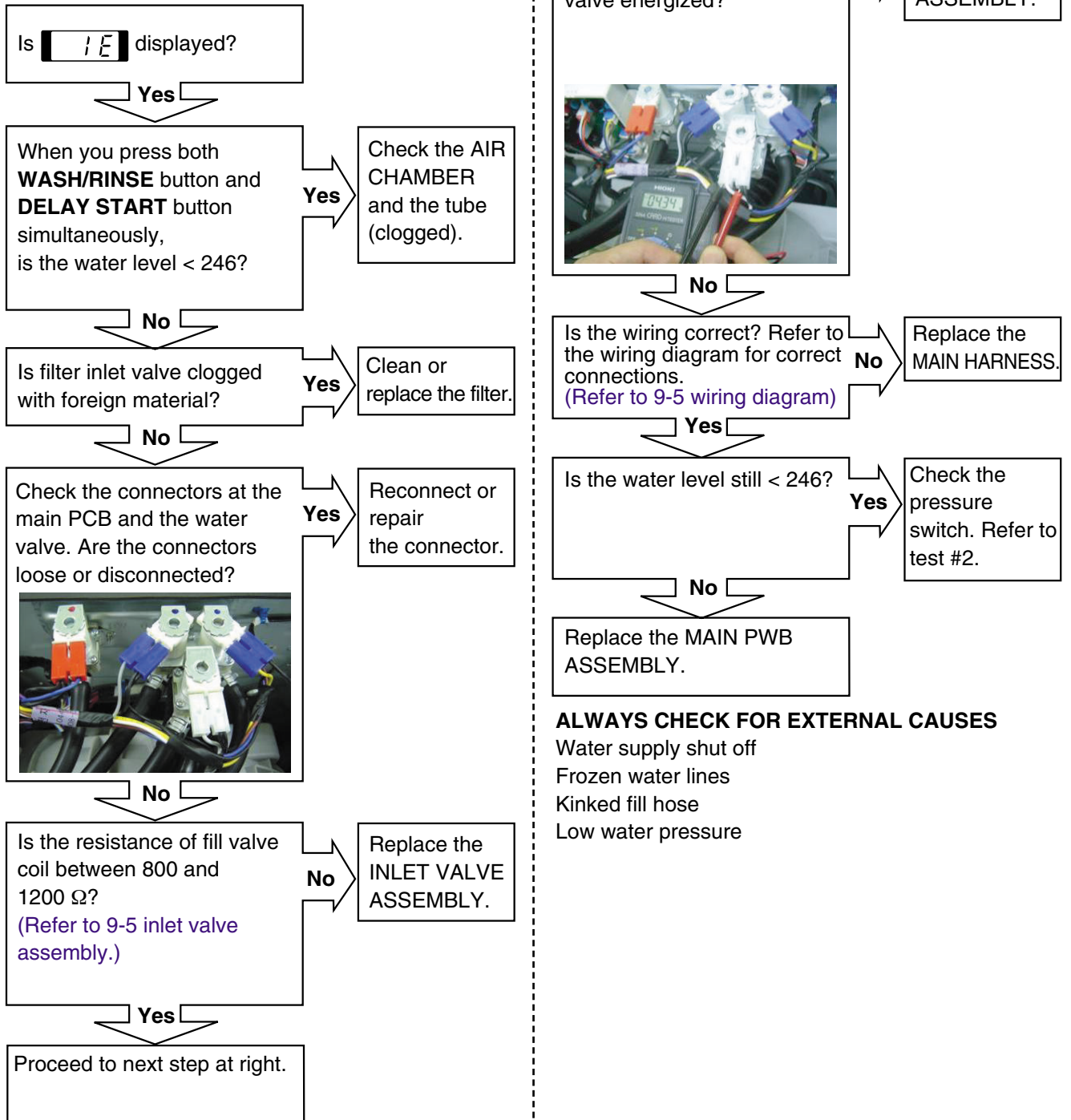

DRAIN ERROR

Is DE displayed?

Yes

Check the connectors at the main PCB and the drain pump. Are the connectors loose or disconnected?

Yes

Reconnect or repair the connector.



Drain pump

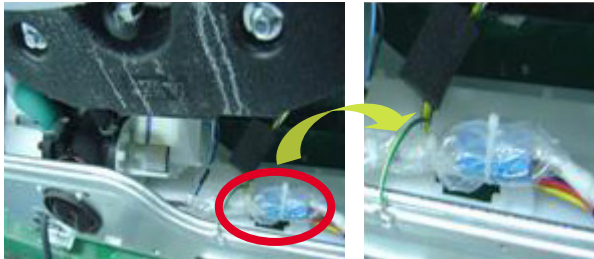

Connection connector

No

When you press both **WASH/RINSE** button and **DELAY START** button simultaneously, is the water level <250?

Yes

Proceed to next step at right

No

Check the air dome and pressure hose for clogging. Check the pressure switch. See test #2.

Measure the resistance of the drain pump motor. Is the resistance between 10Ω and 20Ω ?
(Refer to 9-4 Pump motor assembly.)

Yes

Replace the DRAIN PUMP ASSEMBLY.

No

Check the voltage between the main PCB connectors NA4-1 BN and BL3-1 BK. Is the voltage 120 VAC ± 5%?

No

Replace the MAIN PWB ASSEMBLY.

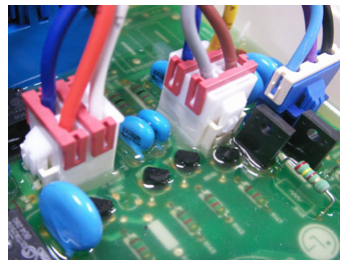

TO TURN ON THE DRAIN PUMP:

1. Turn on the washer
 2. Press the SPIN SPEED button to select LOW speed.
 3. Press the START/PAUSE button.
- The drain pump will be energized for several minutes at the beginning of the spin cycle.

ALWAYS CHECK FOR EXTERNAL CAUSES

- Kinked or clogged drain hose
- Frozen drain hose
- Foreign objects clogging the drain pump filter
- Foreign objects caught in pump impeller

HEATING ERROR

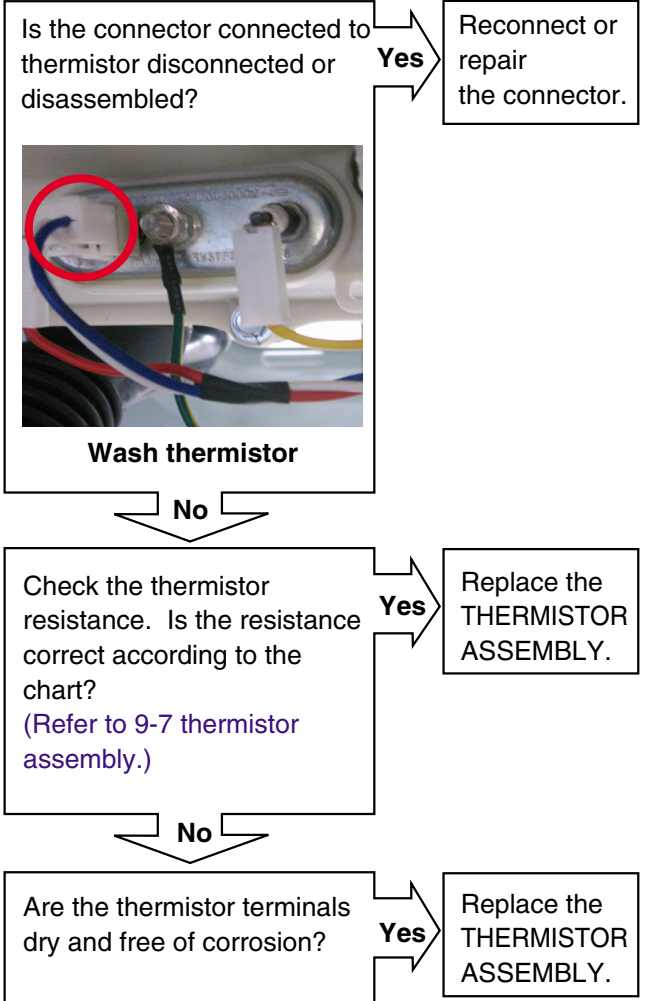
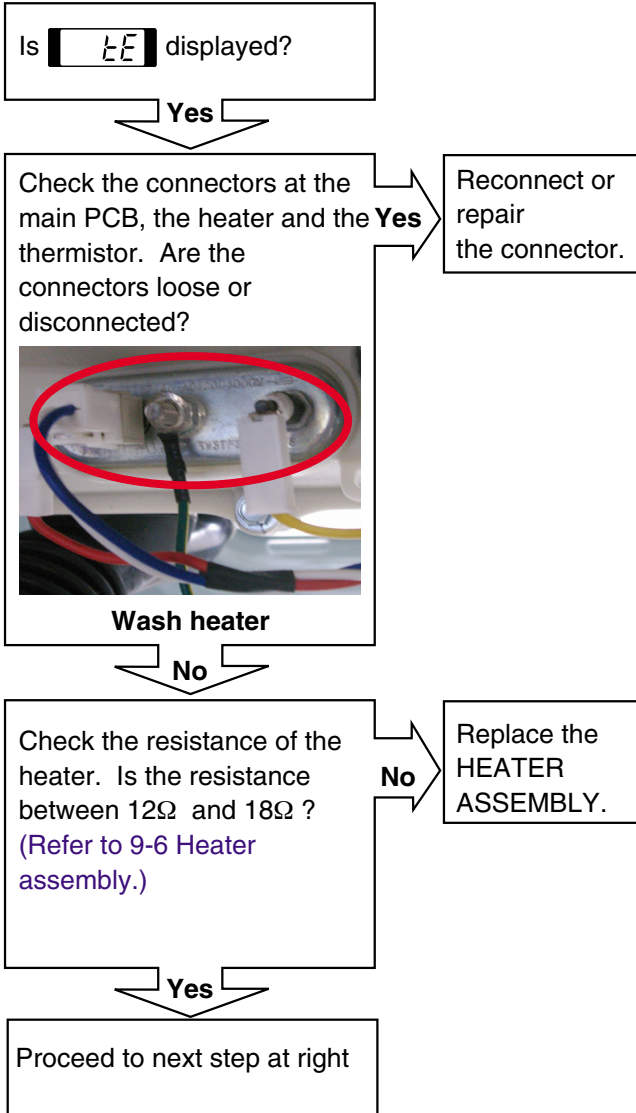

[Note]
 The temperature sensing circuits on the main PCB are very simple, consisting only of resistors and capacitors. Problems with wiring or connections in the thermistor circuit are the most likely cause for this error. Be sure to check ALL connections and wiring thoroughly. The main PCB should only be replaced as a last resort, as it is unlikely to be the cause.

LOCKED MOTOR ERROR

Is **LE** displayed?

Yes

Check the connectors at the main PCB and the main motor. Are the connectors loose or disconnected?
Main PCB connectors RD3 and NA4
Motor connectors to stator and hall sensor

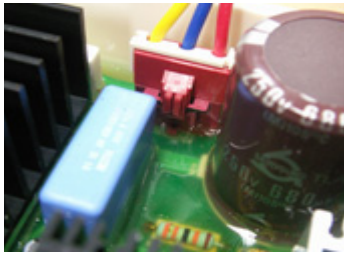

Motor Drive

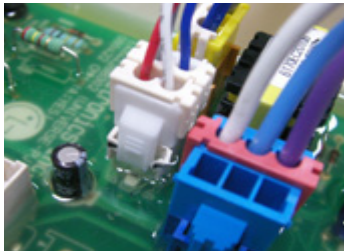

Hall sensor

- part of wire



Motor Drive Hall Sensor

Yes

Reconnect the connector. (connector / wire / motor)

- part of motor

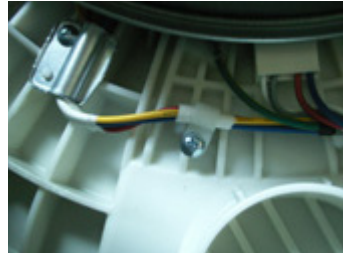

Motor

Yes

Check the resistance of the stator winding from the main PCB connector RD3. Is the resistance between each pair or wires between 5 and 15 ? (Measure pins 1-2, 1-3 and 2-3.)

No

Replace the STATOR.



Yes

Is hall sensor out of order? (Refer to 9-3 Stator assembly/Hall sensor.)

Yes

Replace the Hall sensor.

No

Check the IPM in the controller.

No

Replace the MAIN PWB ASSEMBLY.

Is rotor magnet cracked?

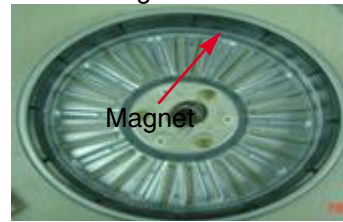

Magnet

Yes

Replace the ROTOR.

DOOR OPEN ERROR

Is  displayed?

Yes

Check the connectors at the main PCB and the door switch. Are the connectors loose or disconnected?



Yes

Reconnect or repair the connector

No

Is the door closing properly?
Is the gasket damaged and interfering with the door or latch?
Are there foreign objects caught in the door?
Is the hinge damaged?



No

Replace Door Assembly

Yes

Proceed to next step at right

Is the spring in the door latch hook on the door strong and tight?

No

Replace gasket or hinge.
Remove foreign objects.

Yes

Can you hear the door latch attempting to lock the door at the beginning of the cycle or diagnostic mode?

No

Replace the PCB ASSEMBLY.

Yes

If tested off the stator using the diagram above ohm check the resistors from pin 5 to pin 1 & pin 2. Does either test show an open (infinity) the hall sensor? (You should measure approximately 10,000 ohms from pin 5 to pin 1 and 10,000 ohms from pin 5 to pin 2)

No

Replace the DOOR SWITCH ASSEMBLY.

UNBALANCE ERROR

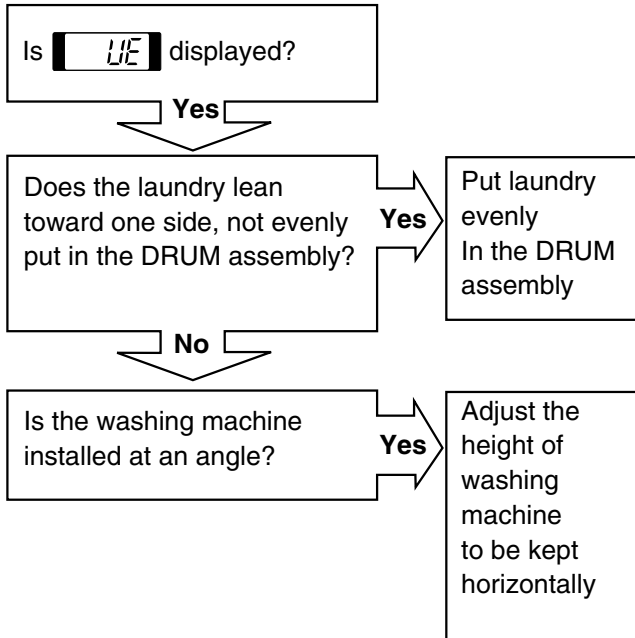

[Note] Environmental check list

- 1) Removal of transportation-based fixed bolt.
- 2) Confirmation on the material to see if it is capable of handling two different types of blanket materials.

OVER FLOW ERROR

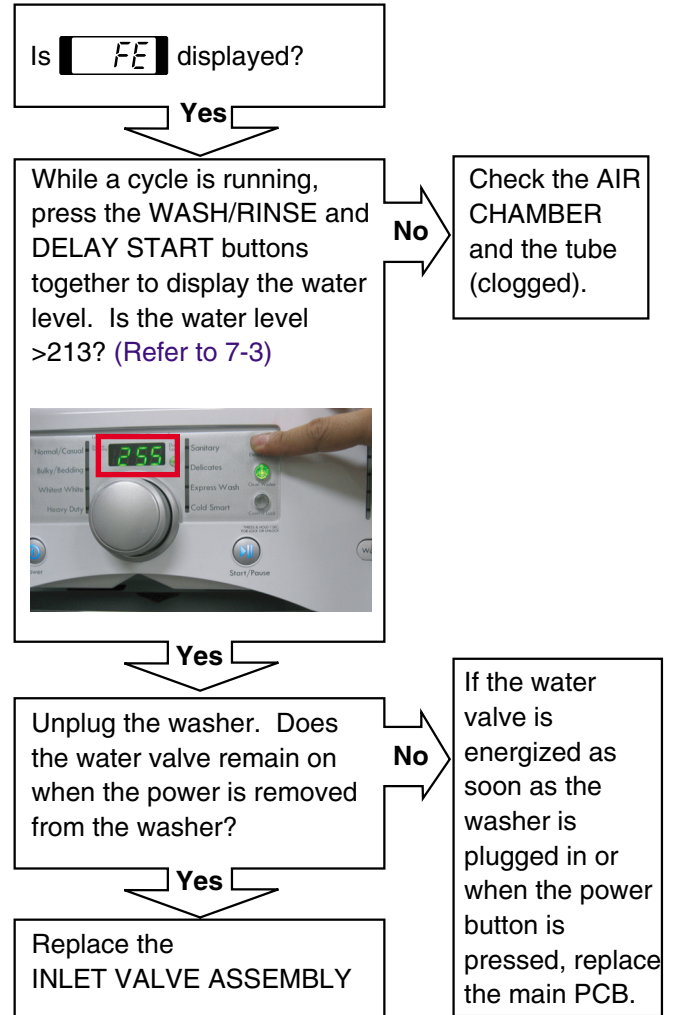

PRESSURE SENSOR ERROR

Is **PE** displayed?

Yes

Check the connectors at the main PCB and the pressure switch. Are the connectors loose or disconnected?



Yes

Reconnect or repair the connector

No

Measure the resistance between pins 1 and 3 of the pressure switch. Is the resistance between 21Ω and 23Ω ?



No

Replace the pressure switch

Yes

Is the AIR CHAMBER and the tube clogged?

Yes

Fix the air chamber and remove the foreign material.

No

Replace the MAIN PWB assembly.

8-5. TROUBLE SHOOTING ELSE

⚠ CAUTION

1. Be careful of electric shock if disconnecting parts while troubleshooting.
2. First of all, check the connection of each electrical terminal with the wiring diagram.
3. If you replace the MAIN PWB ASSEMBLY, reinsert the connectors correctly.

NO POWER

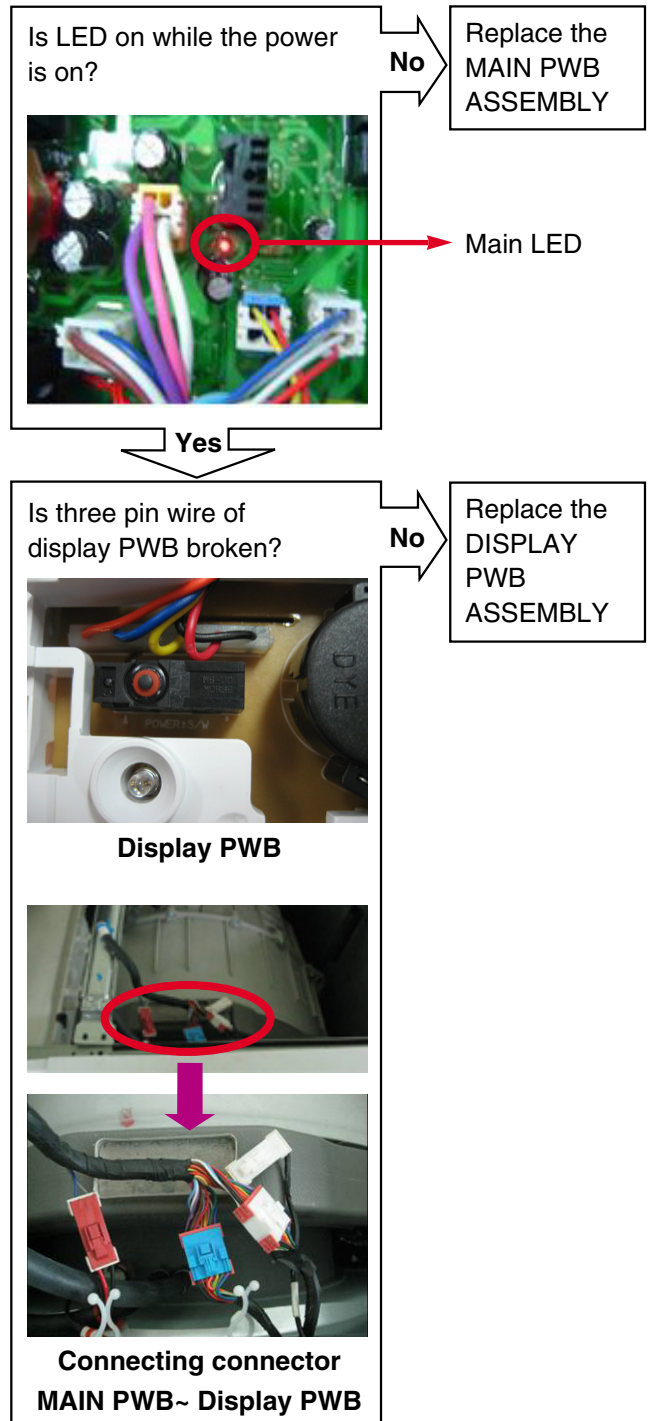
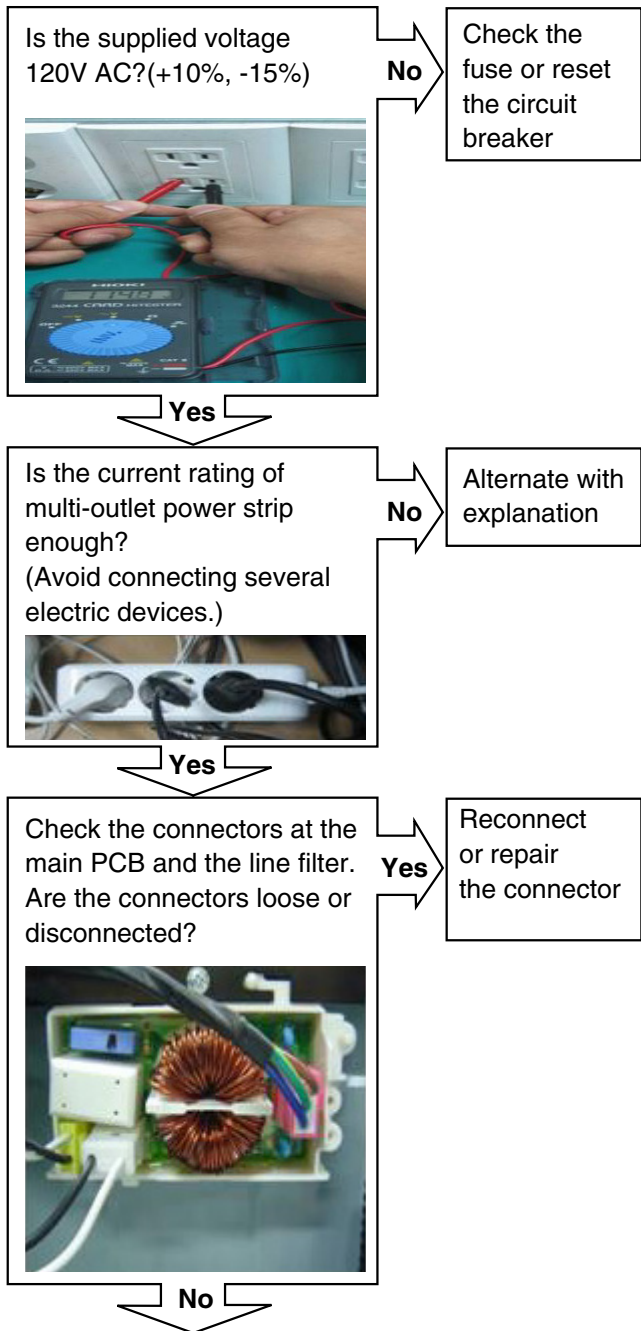

BUTTON DOESN'T WORK

Check the connectors at the main PCB and the line filter. Are the connectors loose or disconnected?

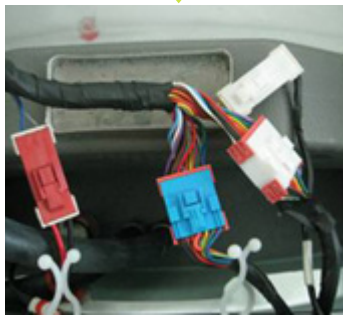
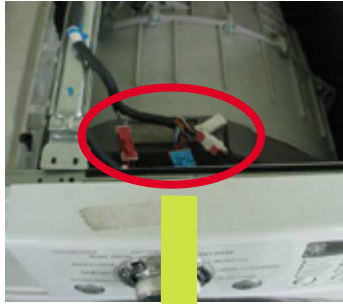

Yes

Reconnect or Repair the connector

No

Check the connectors between the main PCB and the display PCB. Are the connectors loose or disconnected?



POWER

Yes

Replace the main PCB.

No

Replace the main PCB.

VIBRATION & NOISE IN SPIN

Have all the transit bolts and base packing been removed?

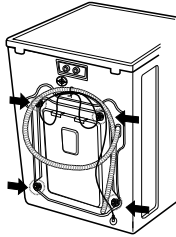

Base Packing

Yes

No

Remove the transit bolts and Base packing.

Is the washer installed on a solidly constructed floor?

Yes

No

Move the washer or reinforce the floor.

Check if the washer is perfectly level as follows:

Check the leveling of the washer with a level and check that the washer is stable.

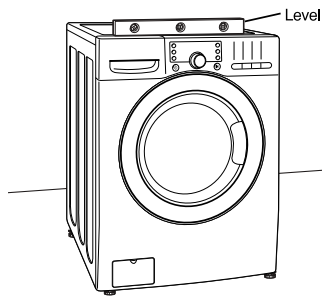

Put an unbalance part (rubber) inside of drum and start QC test mode and run in high spin. (Refer to section 7-2.) When the machine is spinning in high speed, verify that it is stable.

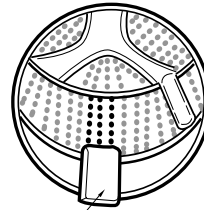

Unbalance Part

If you do not have the unbalance part, put 4.5 to 6.5 lbs (2 to 3 kg) of clothing. Once loaded, press power, Rinse+Spin and the start/pause button in sequence. When the machine is spinning in high speed, verify that it is stable.

Yes

If it is not stable, adjust feet accordingly. After the washer is level, tighten the lock nuts up against of the base of the washer. All lock nuts must be tightened.

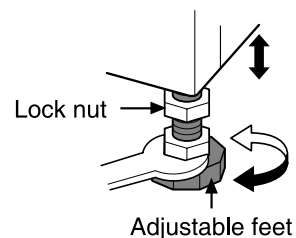

Yes

Check the vibration Sensor.

DETERGENT DOES NOT FLOW IN

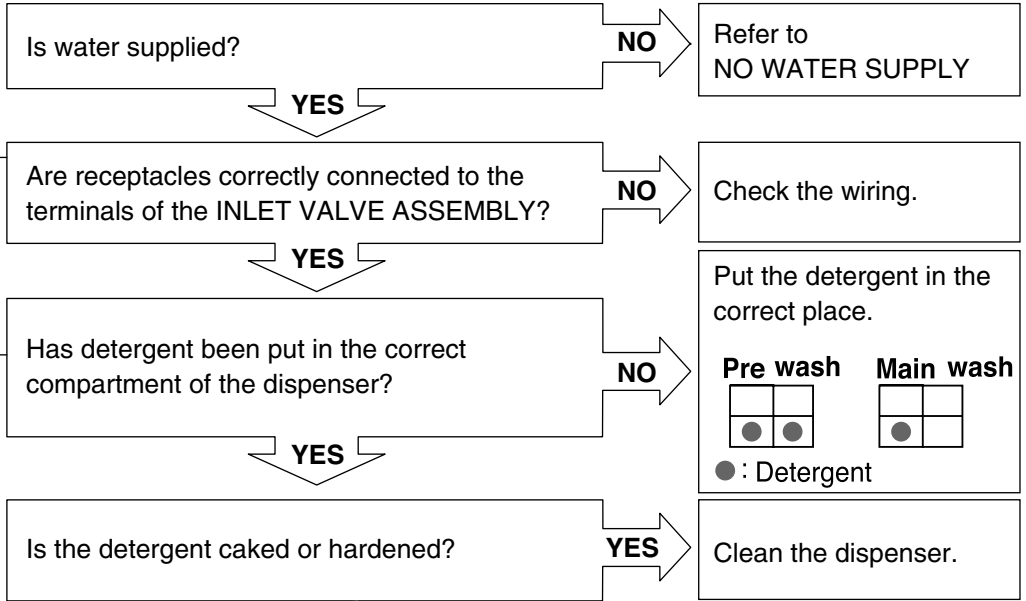
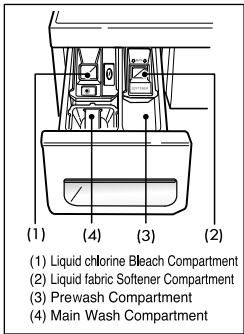
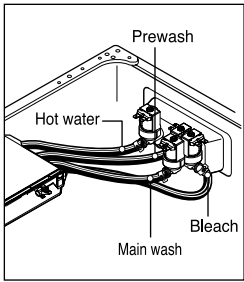

LIQUID DETERGENT/SOFTENER/BLEACH DOES NOT FLOW IN

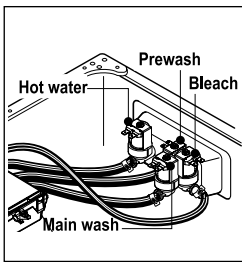

Is water supplied?

NO

Refer to
NO WATER SUPPLY

YES

Are the plugs correctly connected to the terminals of the INLET VALVE ASSEMBLY?

NO

Check the wiring on the dispenser.

YES

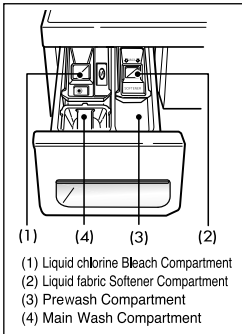

Is liquid detergent/softener/bleach put in the correct compartment of the drawer?

NO

Put it in the correct compartment.

YES

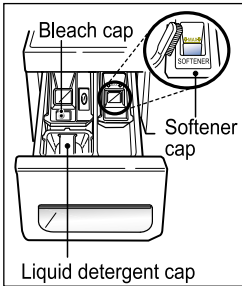

Is the liquid detergent/softener/bleach cap clogged?

YES

Clean the cap and Container.

ABNORMAL SOUND

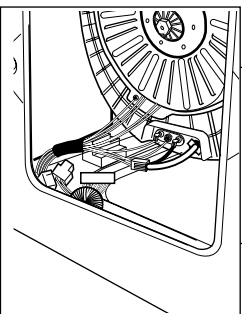

Is the motor bolt loosened?

YES

Secure the bolt.

NO

Is there friction noise coming from the motor?

YES

Check hall sensor.
Replace If defective.
Then check stator.
Replace if necessary.
Check rotor for broken magnets.
Replace rotor if necessary.

9. COMPONENT TESTING INFORMATION

⚠ WARNING When Resistance (Ohm) checking the Component, be sure to turn the power off, and do voltage discharge sufficiently.

9-1. FILTER ASSEMBLY (LINE FILTER)

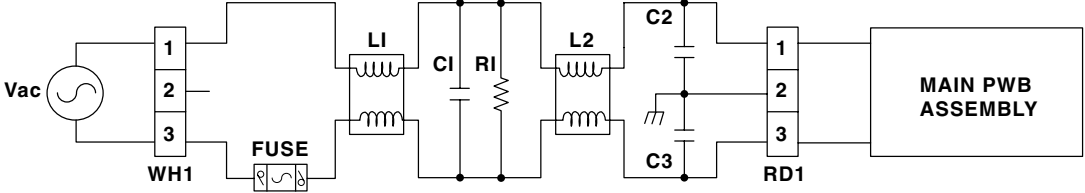
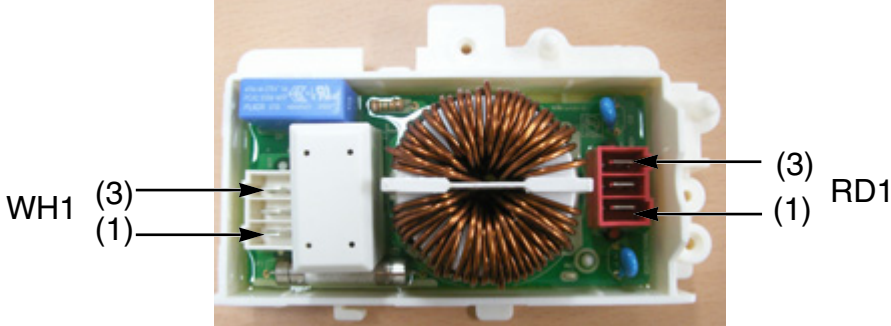
<p>Circuit diagram</p>	<p style="text-align: center;">Circuit in the MAIN PWB/Circuit diagram</p> 						
<p>Test points and Result</p>	 <table border="1" data-bbox="678 1344 1157 1489"> <thead> <tr> <th>Test Points</th> <th>Result</th> </tr> </thead> <tbody> <tr> <td>WH (1) to RD (3)</td> <td>0 Ω</td> </tr> <tr> <td>WH (3) to RD (1)</td> <td>0 Ω</td> </tr> </tbody> </table>	Test Points	Result	WH (1) to RD (3)	0 Ω	WH (3) to RD (1)	0 Ω
Test Points	Result						
WH (1) to RD (3)	0 Ω						
WH (3) to RD (1)	0 Ω						

9-2. DOOR LOCK SWITCH ASSEMBLY

<p>Circuit diagram</p>	<p style="text-align: center;">Circuit in the MAIN PWB</p>
<p>Function</p>	<p>The Door Lock Switch Assembly consists of a Heating PTC, a Bimetal, a Protection PTC, and a Solenoid. It locks the door during a wash cycle.</p> <ol style="list-style-type: none"> 1. Operation for door closing <ul style="list-style-type: none"> - After the system turns on, PTC heating starts up through terminal 2~4's authorizing the power on. - After PTC heating starts up and before solenoid operation is driven, force the system to the off position through CAM. ⇒ Door close - Authorizing one impulse through terminal 3~4 (PTC & solenoid) will make the door locked. - Door lock is detected when switches in terminal 4~5 are set closed. ⇒ CAM rotation will forcibly clear off the connection. <li style="padding-left: 20px;">The maximum, allowable number of impulse authorizations is 2 ⇒ Upon the third authorization of the impulse, the position of CAM goes back to the door-open position. - Authorizing the impulse occurs in 4.5 seconds upon input for max performance and two authorization processes are allowed at most. ⇒ Normal operation period of PTC heating: 1.5 - 5 seconds (Defects from the development process) 2. Operation for door opening <ul style="list-style-type: none"> - With a temporary stop, door automatically opens by CAM rotations after authorizing the impulse from the terminal 3 ~ 4 and the power turns off - maximum of 3 times of the authorizing period - Upon the fourth authorization of the impulse, the position of CAM goes back to the door-close position.

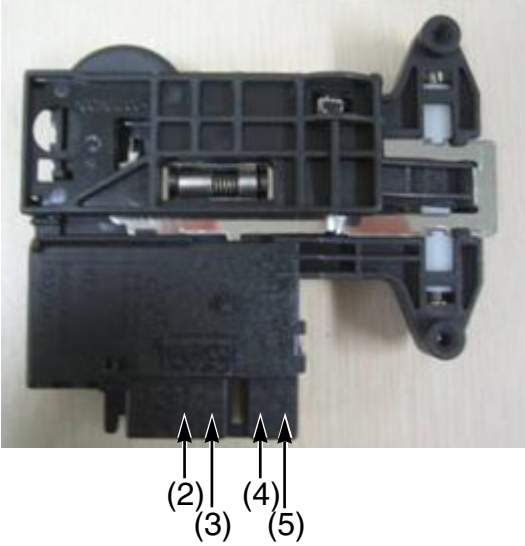
<p>Test points</p>																
<p>Result</p>	<table border="1"> <thead> <tr> <th>Test Points</th> <th>Result</th> <th>Remarks</th> </tr> </thead> <tbody> <tr> <td>(2) to (4)</td> <td>700-1500 Ω</td> <td>At 77°F (25°C)</td> </tr> <tr> <td>(3) to (4)</td> <td>60-90 Ω</td> <td>At 77°F (25°C)</td> </tr> <tr> <td>(4) to (5)</td> <td>Infinity</td> <td></td> </tr> <tr> <td>(2) to (4)</td> <td>120 Vac</td> <td>Voltage Input</td> </tr> </tbody> </table>	Test Points	Result	Remarks	(2) to (4)	700-1500 Ω	At 77°F (25°C)	(3) to (4)	60-90 Ω	At 77°F (25°C)	(4) to (5)	Infinity		(2) to (4)	120 Vac	Voltage Input
Test Points	Result	Remarks														
(2) to (4)	700-1500 Ω	At 77°F (25°C)														
(3) to (4)	60-90 Ω	At 77°F (25°C)														
(4) to (5)	Infinity															
(2) to (4)	120 Vac	Voltage Input														

9-3. STATOR ASSEMBLY

<p>Circuit diagram</p>	<p style="text-align: center;">Circuit in the MAIN PWB</p>								
<p>Function</p>	<p>The DD motor can be driven from stopped to maximum speed in infinite steps in either direction. There are 36 poles on the stator; 12 permanent magnets spaced around the rotor. There are no brushes to wear out. Unlike a more traditional brushless motor, the rotor surrounds the stator rather than being attached to it.</p>								
<p>Test points (Windings)</p>									
<p>Result (Windings)</p>	<table border="1" style="width: 100%; border-collapse: collapse;"> <thead> <tr> <th style="text-align: center;">Test Points</th> <th style="text-align: center;">Result</th> </tr> </thead> <tbody> <tr> <td style="text-align: center;">(1) to (2)</td> <td style="text-align: center;">5-15 Ω</td> </tr> <tr> <td style="text-align: center;">(2) to (3)</td> <td style="text-align: center;">5-15 Ω</td> </tr> <tr> <td style="text-align: center;">(3) to (1)</td> <td style="text-align: center;">5-15 Ω</td> </tr> </tbody> </table>	Test Points	Result	(1) to (2)	5-15 Ω	(2) to (3)	5-15 Ω	(3) to (1)	5-15 Ω
Test Points	Result								
(1) to (2)	5-15 Ω								
(2) to (3)	5-15 Ω								
(3) to (1)	5-15 Ω								

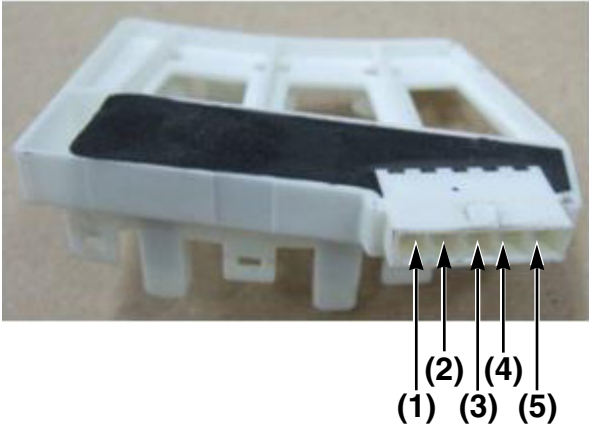
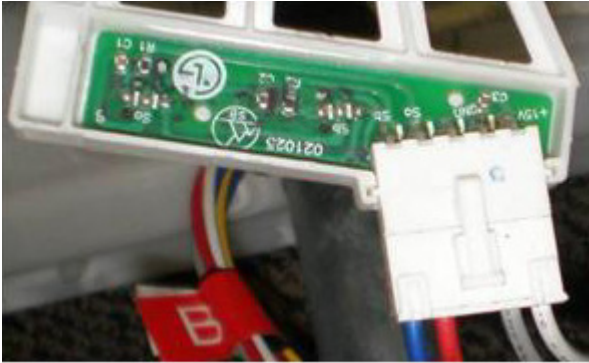
	<p>The hall sensor determines the speed and direction of the motor. It also can read that the load is off balance when the drum speed fluctuates.</p>
<p>Test point and Result (Hall Sensor)</p>	<p>- Voltage Testing Hall Sensor at Stator</p> <div style="text-align: center;">  </div> <div style="text-align: center;">  </div> <p>If measuring voltage from the Main PCB Assembly to the Hall Sensor, use the following steps:</p> <ol style="list-style-type: none"> 1. Unplug power cord. 2. Remove rear washer panel. 3. Locate Hall sensor connector on the stator behind the rotor. 4. Place meter leads on terminals 5 to 4, white to gray. 5. Plug in power cord, close door, and press power button. DO NOT PRESS START! 6. You should measure 10 to 15 Vdc. If 10 to 15 Vdc is present, control board, white wire, and gray wire are OK! If not follow testing output voltages on control board in next section.

7. To measure output signal voltage from the hall sensor, carefully move test leads to terminals 1 to 4, blue and gray. Slowly rotate motor rotor by hand. You should read a pulsing 10 Vdc. If 10 Vdc is measured from 1 to 4, move lead on blue wire to red wire, terminal 2. Repeat rotating motor rotor by hand. You should read a pulsing 10 Vdc from red to gray.
8. If pulsing 10 Vdc is measured from 1 to 4 and 2 to 4, hall sensor is OK! If either test netted only 9 to 10 Vdc without changing (no pulsing) the hall sensor is likely defective. Disconnect power by unplugging washer and ohm check hall sensor to verify failure of the hall sensor.

**Test Point
and
Result
(Hall
Sensor)**

- Voltage Testing Hall Sensor from the Main PCB Assembly

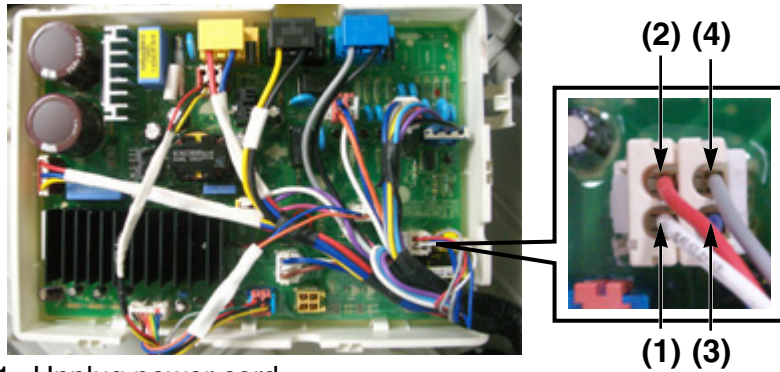

1. Unplug power cord.
2. Remove rear panel.
3. Remove Washer Top.
4. Remove Main PCB Assembly cover as shown in Figure below.
5. Locate the white Hall Sensor 4 wire connector using wiring diagram wire colors as your guide.
6. Plug in power cord, close door, and press power button. **DO NOT PRESS START!**
7. Place meter leads on White & Gray wires. You should read 10 to 15 Vdc output from the Main PCB Assembly to the Hall sensor. If no 10 to 15 Vdc is measured the control board is defective.
8. Place meters leads on Blue to Gray. Turn motor rotor slowly by hand. You should measure a pulsing 10 Vdc. Place meter leads on Red to Gray. Turn motor rotor slowly by hand. You should measure a pulsing 10 Vdc. If both tests measure a pulsing 10 Vdc, hall sensor and harness OK. If either or both tests measures 9 to 10 volts, but does not pulse or change, Hall sensor has failed and must be replaced. IF zero (0) voltage is measured on either test, check red & blue wires for continuity. Repair or replace harness as needed.

Test Points	Result	Remarks
(1) to (2)	8-12 kΩ	
(1) to (3)	8-12 kΩ	
(1) to (4)	10-15 Vdc	Voltage Input
(2) to (4)	10 Vdc	Pulsing Signal
(3) to (4)	10 Vdc	Pulsing Signal

9-4. PUMP MOTOR ASSEMBLY

<p>Circuit diagram</p>	<div style="display: flex; justify-content: space-around;"> <div style="border: 1px solid gray; padding: 5px; background-color: #f0f0f0; width: 45%;"> <p style="text-align: center;">Circuit in the MAIN PWB</p> <p style="text-align: center;">Pump Driving circuit</p> </div> <div style="border: 1px solid gray; padding: 5px; background-color: #f0f0f0; width: 45%;"> <p style="text-align: center;">Circuit diagram</p> <p style="text-align: center;">DRAIN PUMP</p> </div> </div> <p style="text-align: center;">* Each circuits of loads in wiring diagram are all same.</p>				
<p>Object</p>	<p style="text-align: center;">For Drain</p>				
<p>Function</p>	<p>Two pump motors are used to drain the tub and to circulate the water / detergent solution.</p>				
<p>Test points</p>	<p style="text-align: center;">Drain Pump</p> <div style="display: flex; align-items: center;"> <div style="margin-left: 20px;"> </div> </div>				
<p>Result</p>	<p style="text-align: center;">Drain Pump</p> <table border="1" style="margin-left: auto; margin-right: auto;"> <thead> <tr> <th>Test Points</th> <th>Result</th> </tr> </thead> <tbody> <tr> <td>(1) to (2)</td> <td>10-20 Ω</td> </tr> </tbody> </table>	Test Points	Result	(1) to (2)	10-20 Ω
Test Points	Result				
(1) to (2)	10-20 Ω				

9-5. INLET VALVE ASSEMBLY

Circuit diagram

Circuit in the MAIN PWB

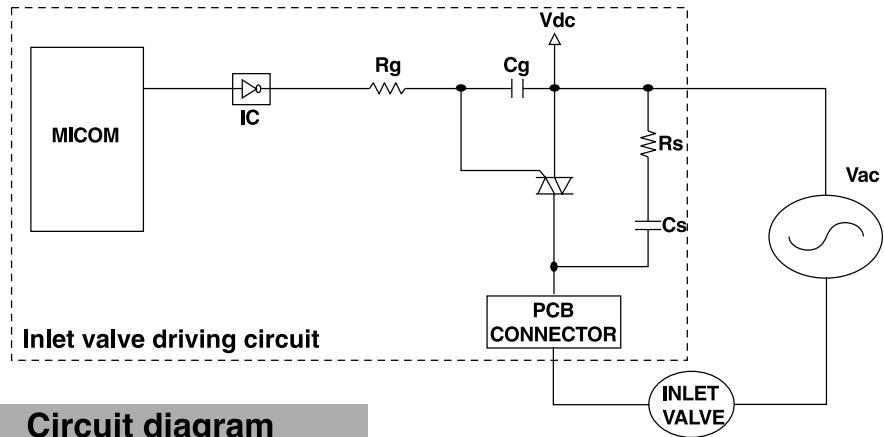

Circuit diagram

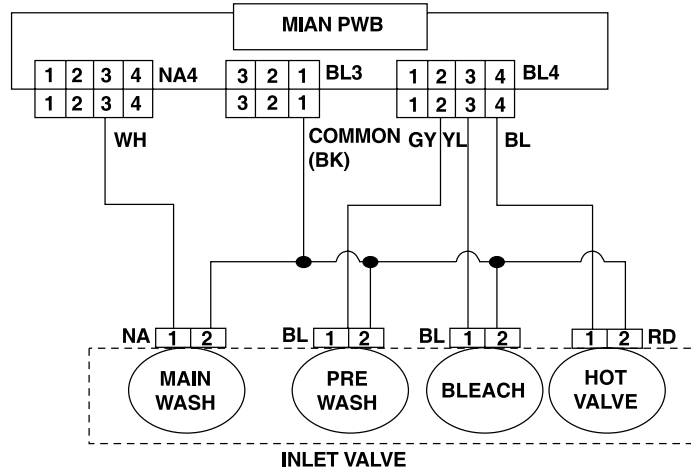

* Each circuits of loads in wiring diagram are all same.

Function

Depending on the cycle and water temperature, the controller will energize the hot or cold water valve solenoids to meet the selected water temperature.

Test points

After pull out the connector of defective valve, check the resistance.

and

Result

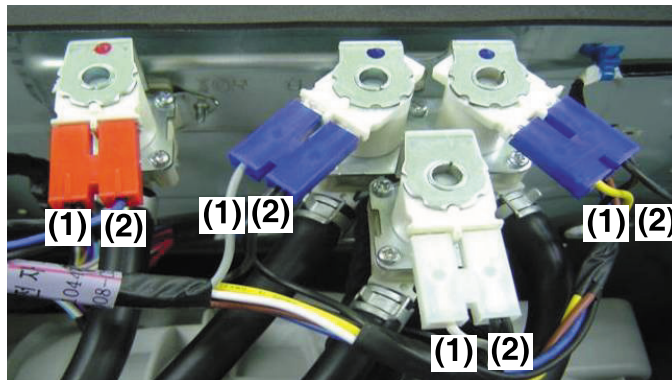

Test points	(1)-(2)
Result	0.8-1.2 kΩ

9-6. HEATER ASSEMBLY

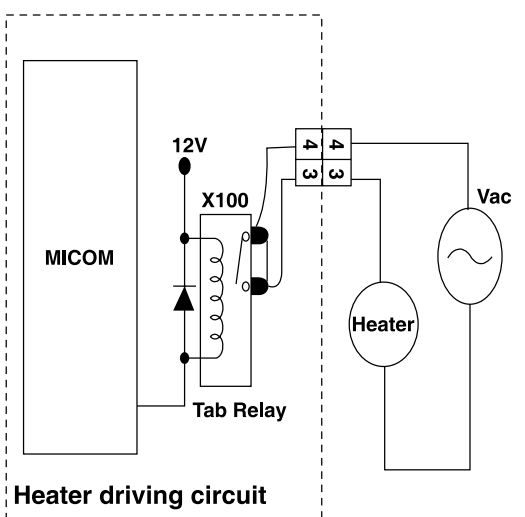
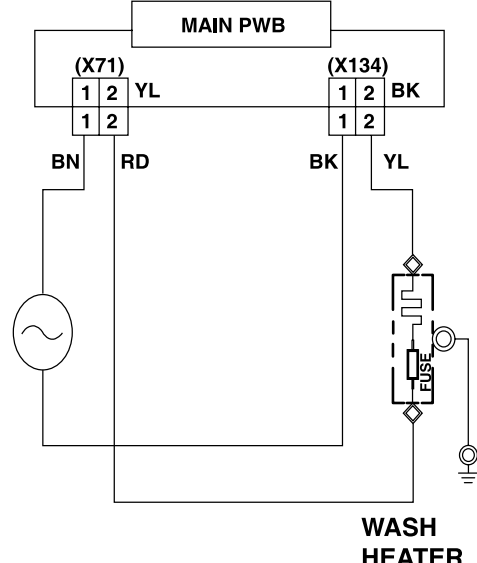
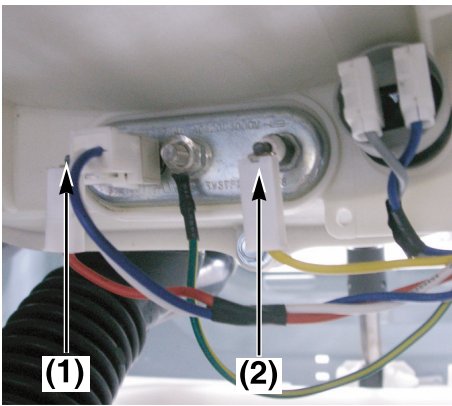
<p>Circuit diagram</p>	<div style="display: flex; justify-content: space-around;"> <div style="border: 1px solid gray; padding: 5px; background-color: #f0f0f0;"> <p style="text-align: center;">Circuit in the MAIN PWB</p>  <p style="text-align: center;">Heater driving circuit</p> </div> <div style="border: 1px solid gray; padding: 5px; background-color: #f0f0f0;"> <p style="text-align: center;">Circuit diagram</p>  <p style="text-align: center;">WASH HEATER</p> </div> </div> <p style="text-align: center;">* Each circuits of loads in wiring diagram are all same.</p>						
<p>Function</p>	<p>1. The Wash Heater is designed to raise the wash water to the desired temperature selection during certain wash cycles.</p>						
<p>Test points</p>	 <p style="text-align: center;">Wash Heater</p>						
<p>Result</p>	<table border="1" style="margin-left: auto; margin-right: auto;"> <thead> <tr> <th colspan="2" style="text-align: center;">Wash Heater</th> </tr> <tr> <th style="text-align: center;">Test Points</th> <th style="text-align: center;">Result</th> </tr> </thead> <tbody> <tr> <td style="text-align: center;">(1) to (2)</td> <td style="text-align: center;">12-18 Ω</td> </tr> </tbody> </table>	Wash Heater		Test Points	Result	(1) to (2)	12-18 Ω
Wash Heater							
Test Points	Result						
(1) to (2)	12-18 Ω						

9-7. THERMISTOR ASSEMBLY

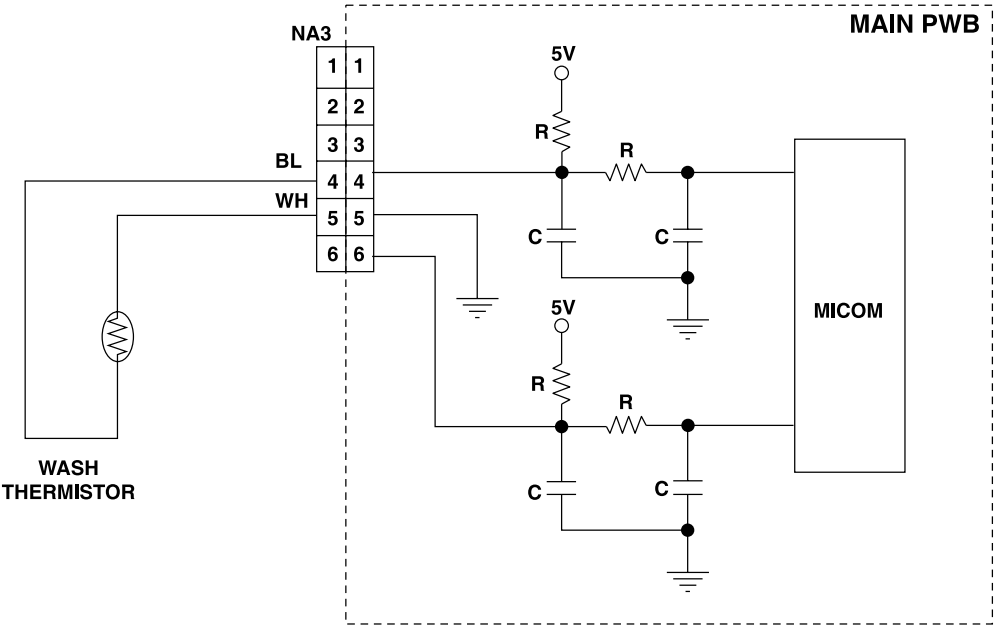
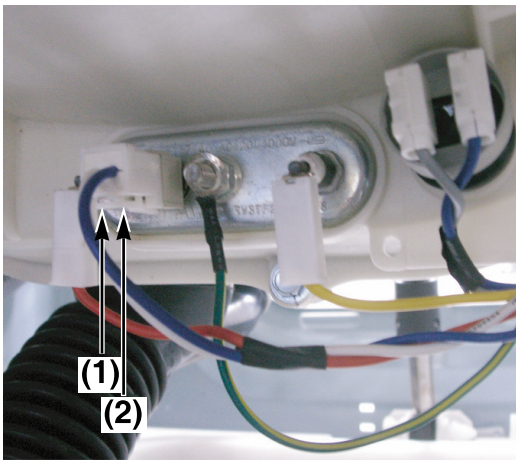
<p>Circuit diagram</p>	<p style="text-align: center;">Circuit in the MAIN PWB / Circuit diagram</p> 																	
<p>Function</p>	<p>The thermistor (temperature sensor) is used to monitor water temperature in the tub.</p>																	
<p>Test points & Result</p>	 <table border="1" data-bbox="949 1232 1484 1635"> <thead> <tr> <th>Test Points</th> <th>Result (tolerance $\pm 5\%$)</th> <th>Remarks</th> </tr> </thead> <tbody> <tr> <td rowspan="2">(1)</td> <td>39.5 kΩ</td> <td>At 86°F (30°C)</td> </tr> <tr> <td>26.1 kΩ</td> <td>At 104°F (40°C)</td> </tr> <tr> <td rowspan="4">(2)</td> <td>12.1 kΩ</td> <td>At 140°F (60°C)</td> </tr> <tr> <td>8.5 kΩ</td> <td>At 158°F (70°C)</td> </tr> <tr> <td>3.8 kΩ</td> <td>At 203°F (95°C)</td> </tr> <tr> <td>2.8 kΩ</td> <td>At 221°F (105°C)</td> </tr> </tbody> </table> <p style="text-align: center;">Wash Thermistor</p>	Test Points	Result (tolerance $\pm 5\%$)	Remarks	(1)	39.5 k Ω	At 86°F (30°C)	26.1 k Ω	At 104°F (40°C)	(2)	12.1 k Ω	At 140°F (60°C)	8.5 k Ω	At 158°F (70°C)	3.8 k Ω	At 203°F (95°C)	2.8 k Ω	At 221°F (105°C)
Test Points	Result (tolerance $\pm 5\%$)	Remarks																
(1)	39.5 k Ω	At 86°F (30°C)																
	26.1 k Ω	At 104°F (40°C)																
(2)	12.1 k Ω	At 140°F (60°C)																
	8.5 k Ω	At 158°F (70°C)																
	3.8 k Ω	At 203°F (95°C)																
	2.8 k Ω	At 221°F (105°C)																

10. DISASSEMBLY INSTRUCTIONS

* Be sure to unplug the machine before disassembling and repairing the parts.

CONTROL PANEL ASSEMBLY

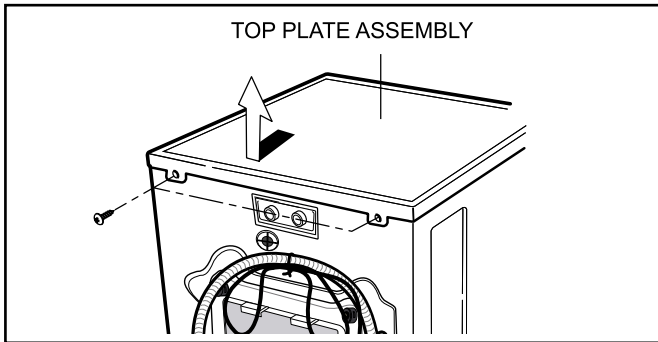

- ① Unscrew 2 screws on the back of the top plate.
- ② Pull the top plate backward and upward as shown.

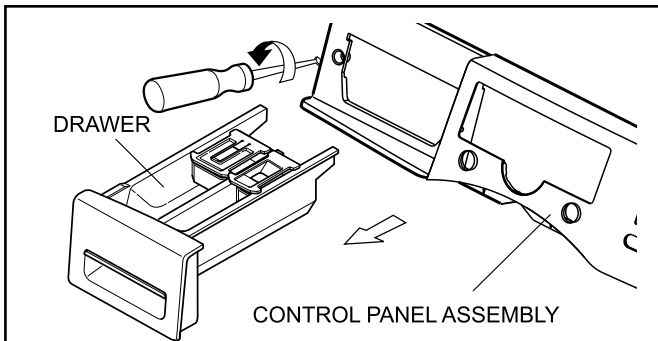

- ③ Disconnect the Display PWB assembly connector from trans cable.
- ④ Pull out the drawer and unscrew 2 screws.

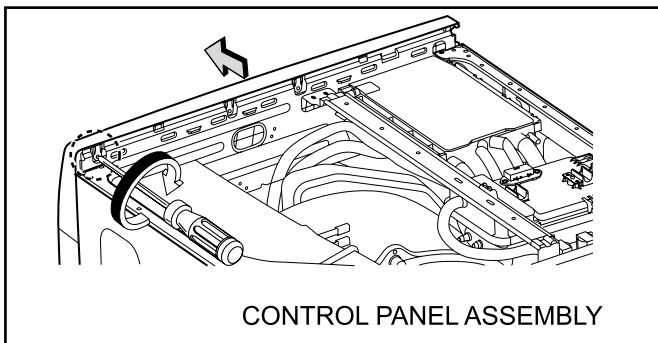

- ⑤ Remove one screw.
- ⑥ Lift the side the control panel assembly and pull it out

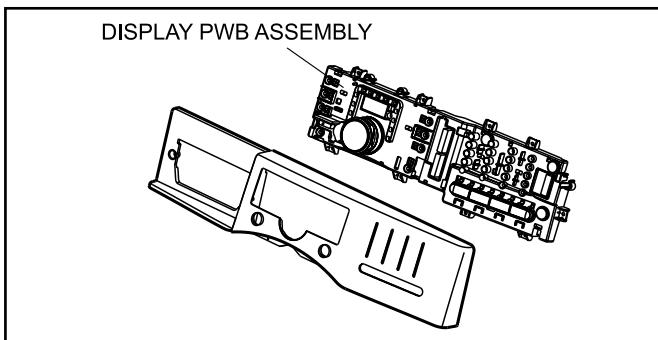

- ⑦ Unscrew the 9 screws(M4), 1 screw(M3) from the control panel assembly.
- ⑧ Disassemble the Display PWB Assembly.

MAIN PWB ASSEMBLY

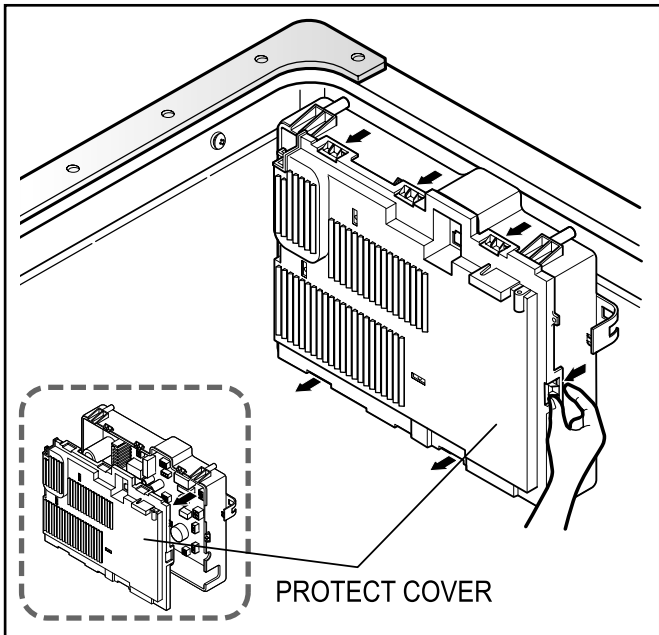

- ① Disconnect the POWER connector and SENSOR SWITCH ASSEMBLY.
- ② Remove the Protective cover.

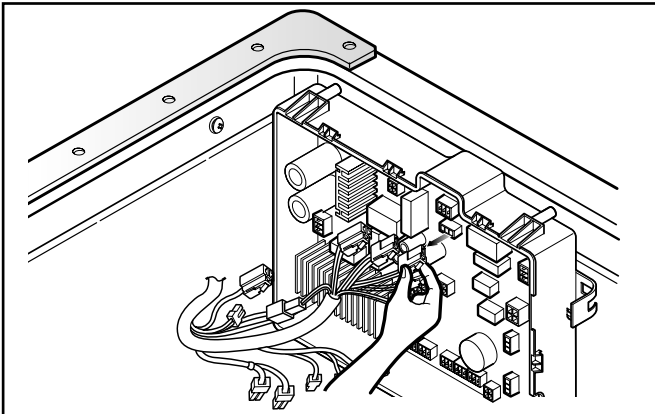

- ③ Disconnect the connectors.

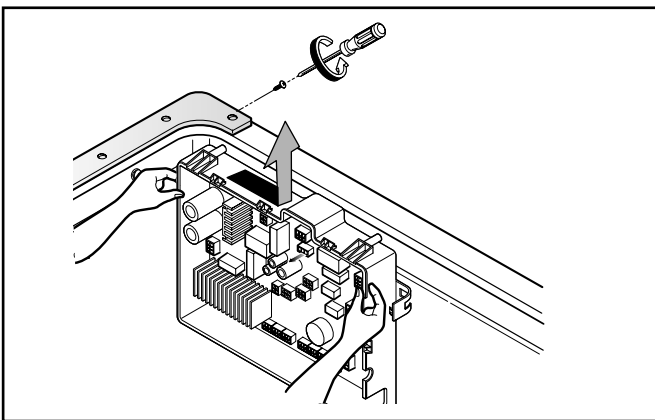

- ④ Unscrew 1 screw on the back.
- ⑤ Remove the Main PWB.

DISPENSER ASSEMBLY

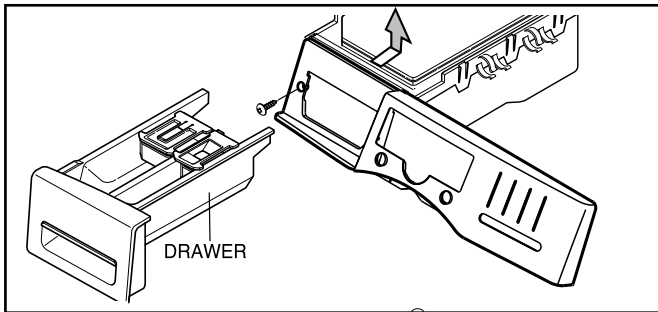

- ① Disassemble the top plate assembly.
- ② Pull out the drawer.
- ③ Push out the DISPENSER ASSEMBLY after unscrewing 2 screws.

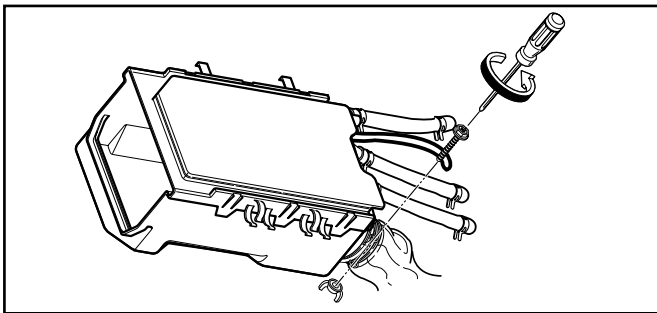

- ④ Unscrew the Clamp nut at the lower part of the dispenser.

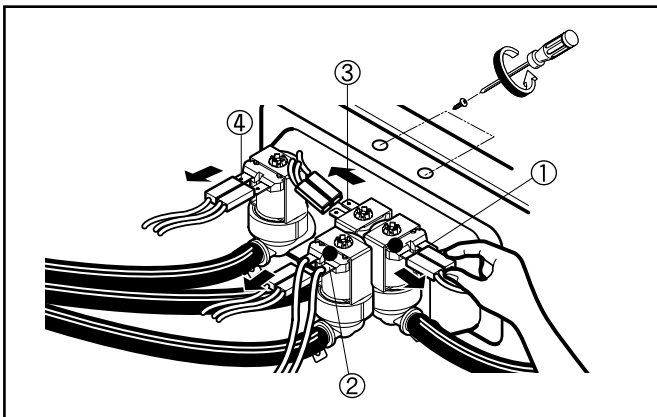

- ⑤ Disassemble the 4 connectors from the valves.

※ Wire Color

- ① Blue Housing (YL-BK)
- ② White Housing (BK-WH)
- ③ Blue Housing (BK-GY)
- ④ Red Housing (BK-Blue)

- ⑥ Unscrew 2 screws from the back of the cabinet.

NOISE FILTER

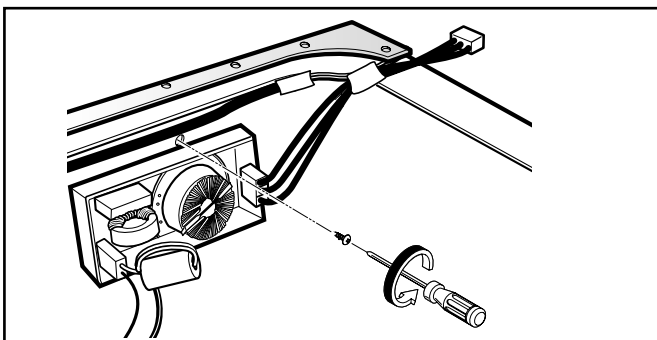

- ① Disassemble two (or three) connectors from the NOISE FILTER.
- ② Unscrew a screw from the TOP BRACKET.

CABINET COVER

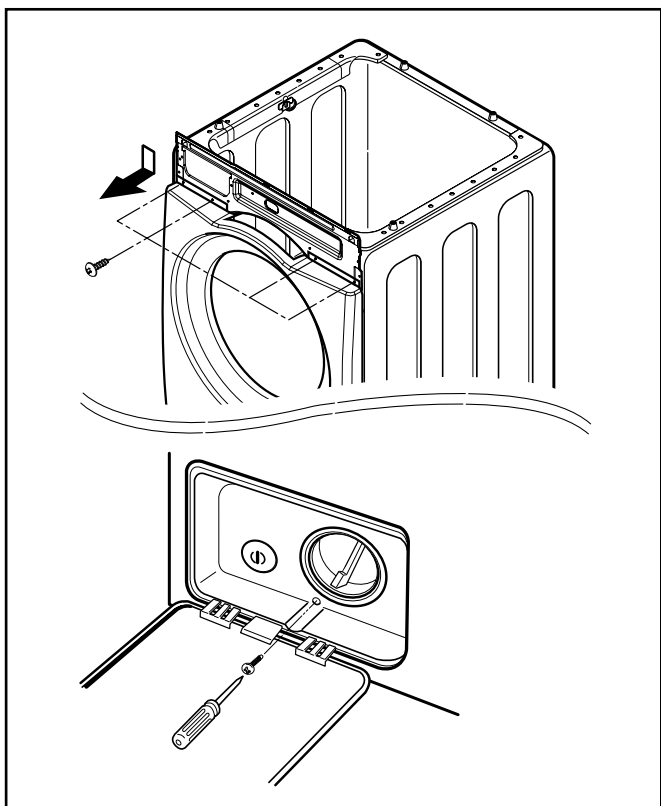

- ① Unscrew the 5 screws from upper of the cabinet cover.
- ② Unscrew the screw from filter cover.

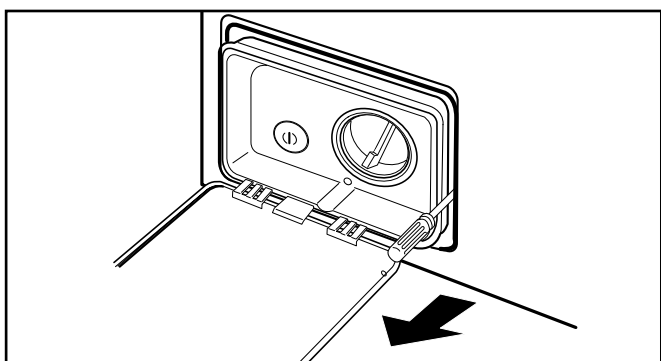

- ③ Put a flat (-) screwdriver or putty knife into the hinge slots at the bottom of the cover and pry it out.

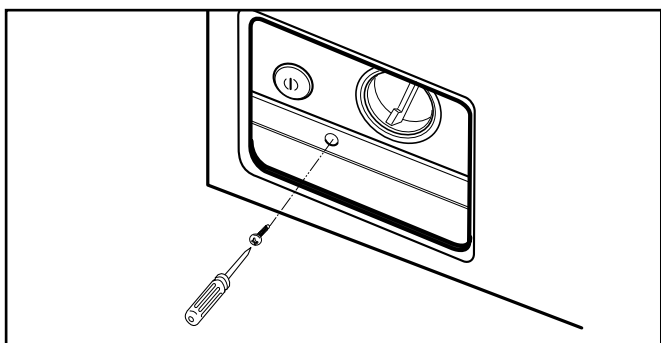

- ④ Unscrew the screw from the lower side of the cabinet cover.

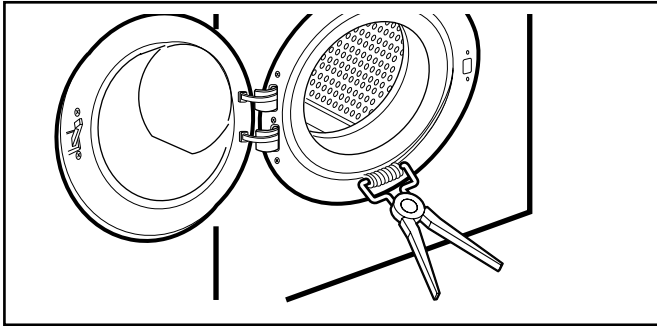

⑤ Open the door.

⑥ Disassemble the clamp assembly.

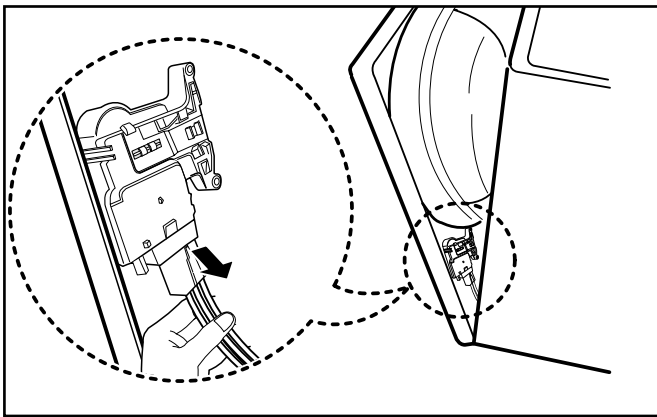

⑦ Tilt the cabinet cover.

⑧ Disconnect the door switch connector.

※ **NOTE:** When assembling the CABINET COVER, connect the door switch connector.

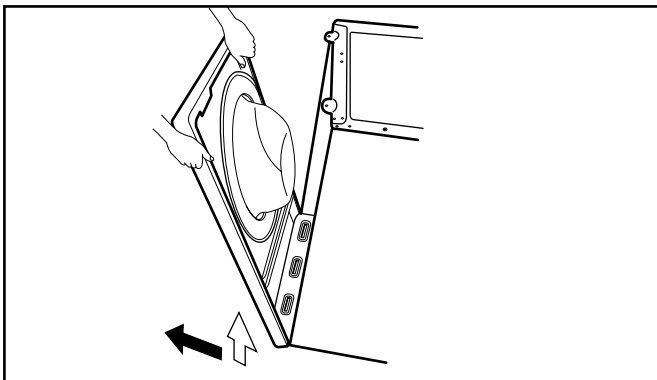

⑨ Lift and separate the cabinet cover.

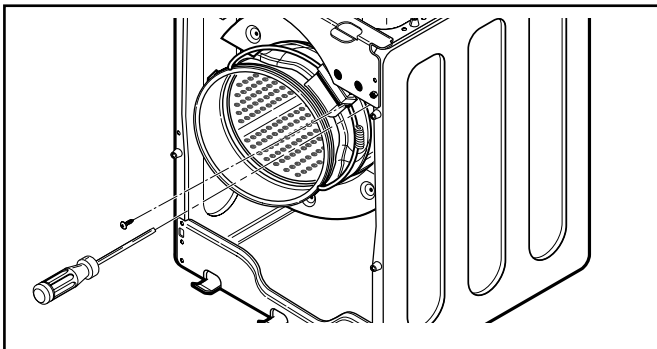

⑩ Disassemble the clamp assembly.

⑪ Disassemble the gasket.

DOOR

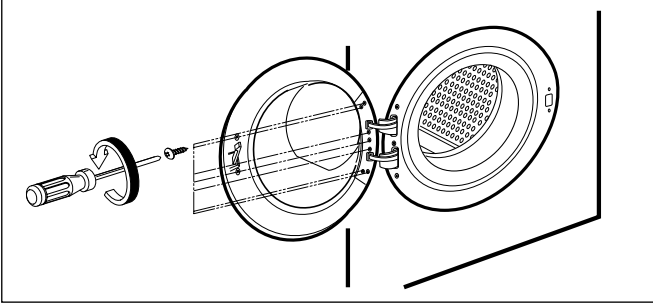

- ① Open the door.
- ② Unscrew the 7 screws from the HINGE COVER.

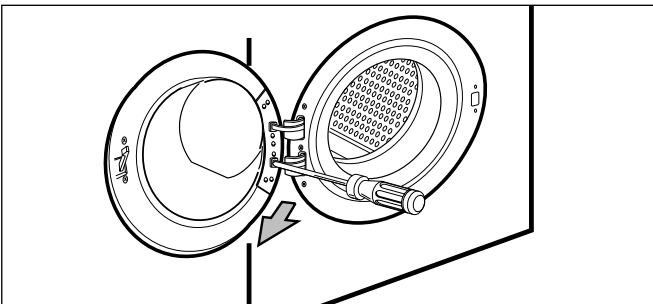

- ③ Put a flat (-) screwdriver into the opening of the hinge, and pull out the hinge cover.

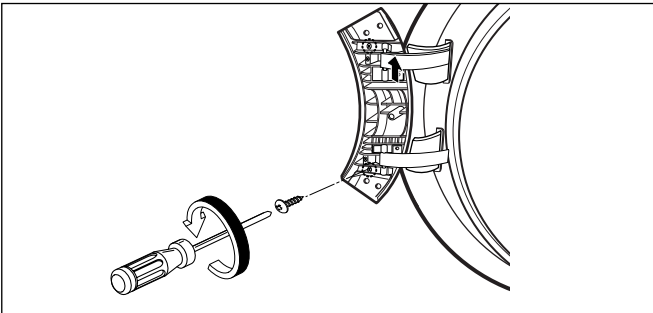

- ④ Unscrew a screw from the lower side of door.
- ⑤ Disassemble the door upward.

※ **Be careful!** The door is heavy.

DOOR LOCK SWITCH ASSEMBLY

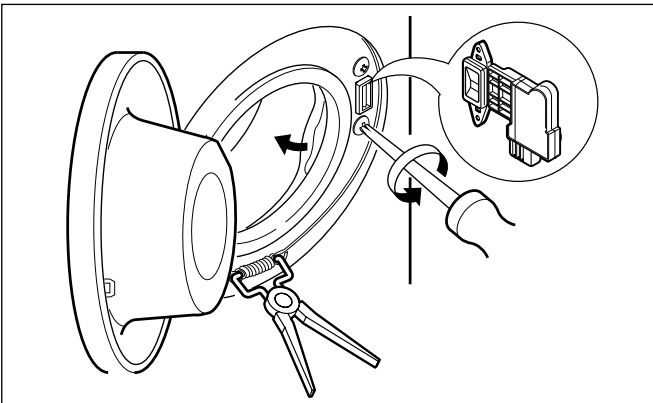

- ① Open the door and disassemble the CLAMP ASSEMBLY.
- ② Unscrew the 2 screws.

※ NOTE

- Reconnect the connector after replacing the DOOR SWITCH ASSEMBLY.

PUMP

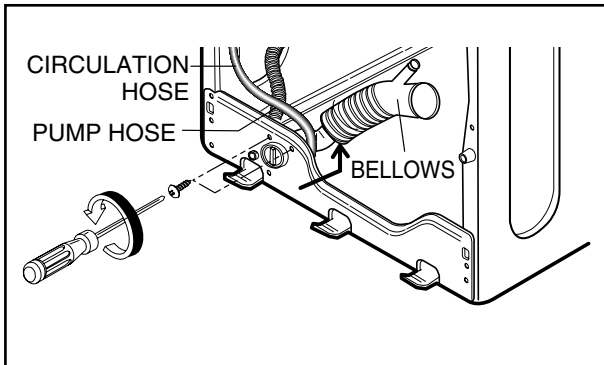

- ① Disassemble the cabinet cover.
- ② Separate the pump hose, the bellows and the circulation hose assembly from the pump assembly.
- ③ Disassemble the pump assembly in arrow direction.

HEATER

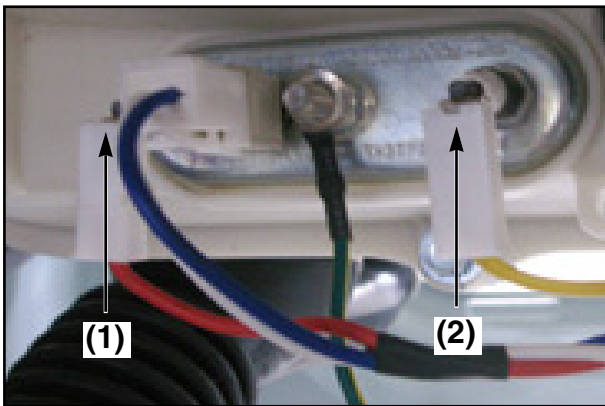

- ① Disassemble the cabinet cover.
- ② Separate 2 connectors from the heater.
- ③ Loosen the nut and pull out the heater.

※ CAUTION

- When assembling the heater, insert the heater into the heater clip on the bottom of the tub.
- Tighten the fastening nut so the heater is secure.

THERMISTOR

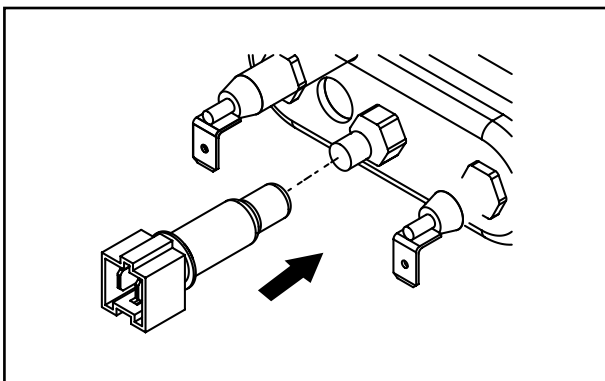

- ① Disassemble the cabinet cover.
- ② Unplug the white connector from the thermistor.
- ③ Pull it out by holding the bracket of the thermistor.

WHEN FOREIGN OBJECT IS STUCK BETWEEN DRUM AND TUB

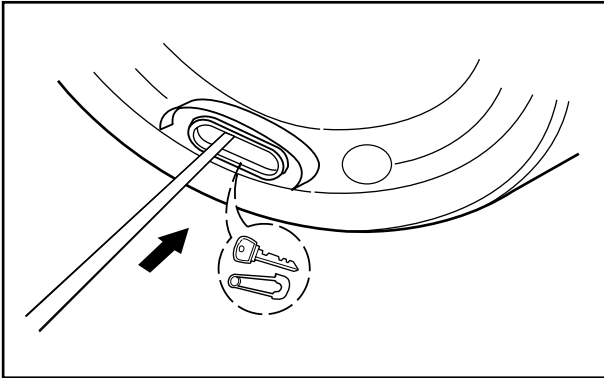

- ① Disassemble the cabinet cover.
- ② Separate the heater from the tub.
- ③ Remove any foreign objects (wire, coin, etc.) by inserting a long bar in the opening.

MOTOR/DAMPER

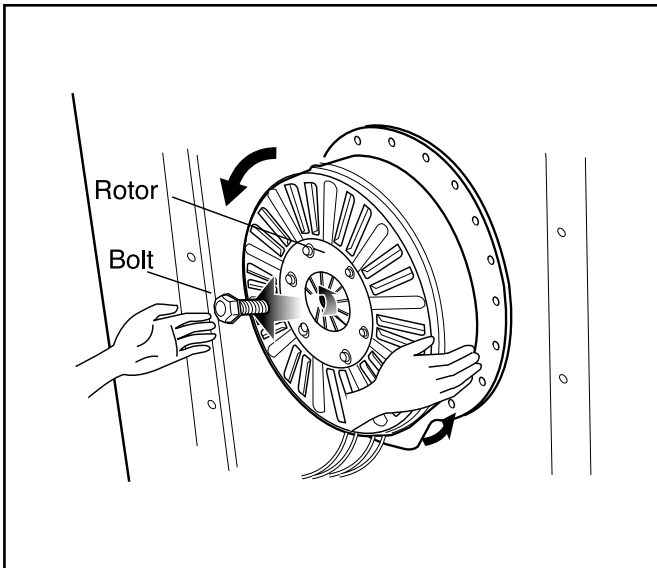

- ① Disassemble the back cover.
- ② Remove the bolt.
- ③ Pull out the Rotor.

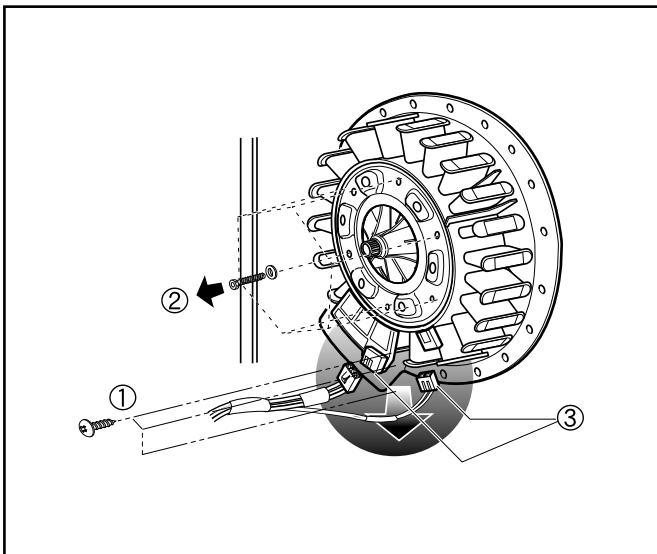

- ① Unscrew the 2 screws from the tub bracket.
- ② Remove the 6 bolts on the stator.
- ③ Unplug the 2 connectors from the stator.

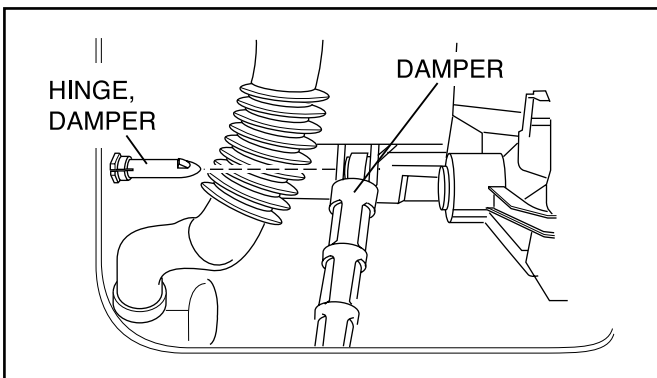

- ① Disassemble the damper hinges from the tub and base.

※ NOTE

If you pull the dampers apart, they must be replaced. If you do not separate them, they can be re-used.

11. EXPLODED VIEW

11-1. CABINET & CONTROL PANEL ASSEMBLY

"The following parts are not illustrated"

Description	Loc No.
+Owner's Manual	(C00)
+Energy Label	(C00)
+Tech Sheet	(C00)
Printed materials	
+Service Manual	(C00)
+Quick Start Guides	(C00)
+Installation Sheet	(C00)

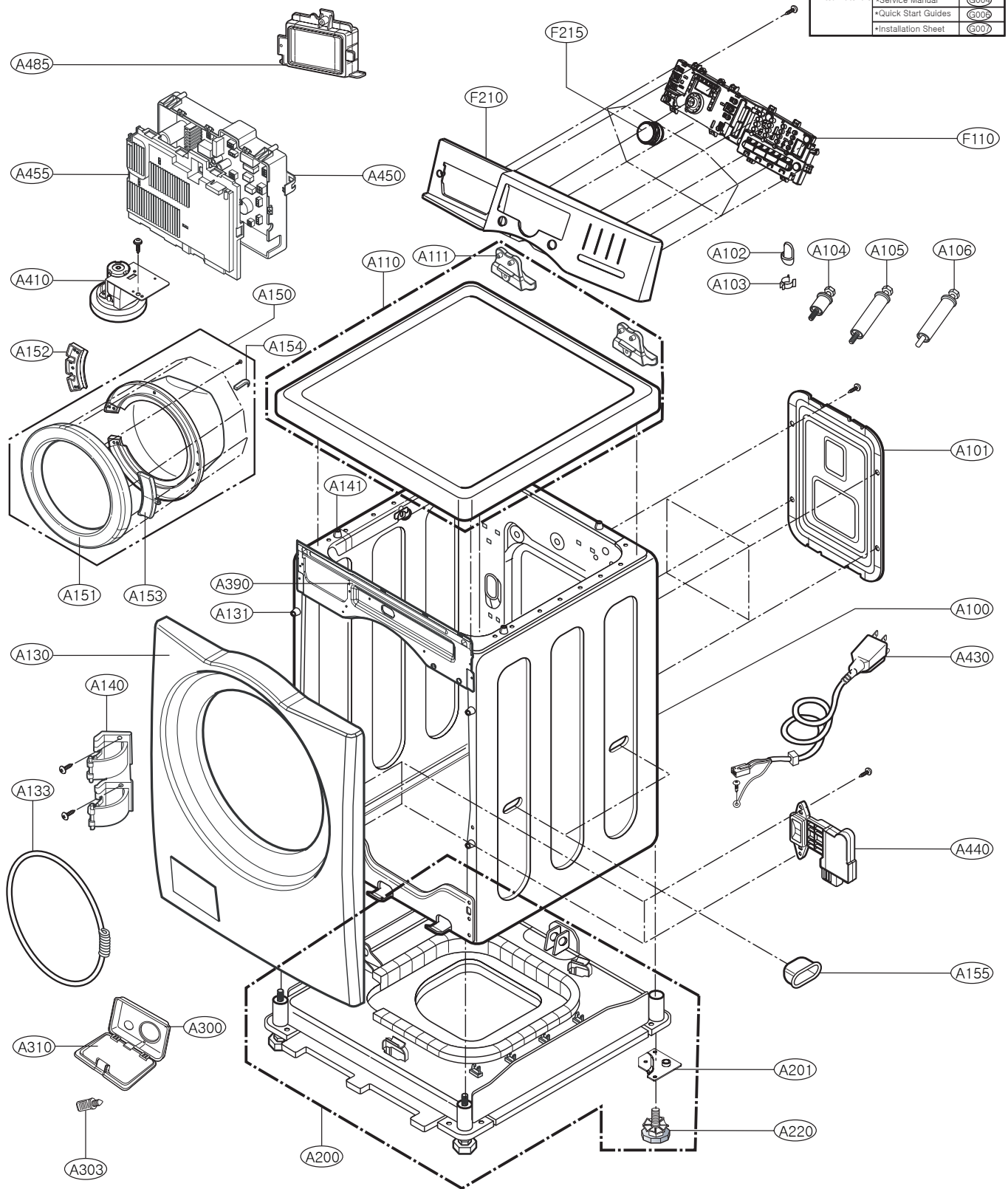

11-2. DRUM & TUB ASSEMBLY

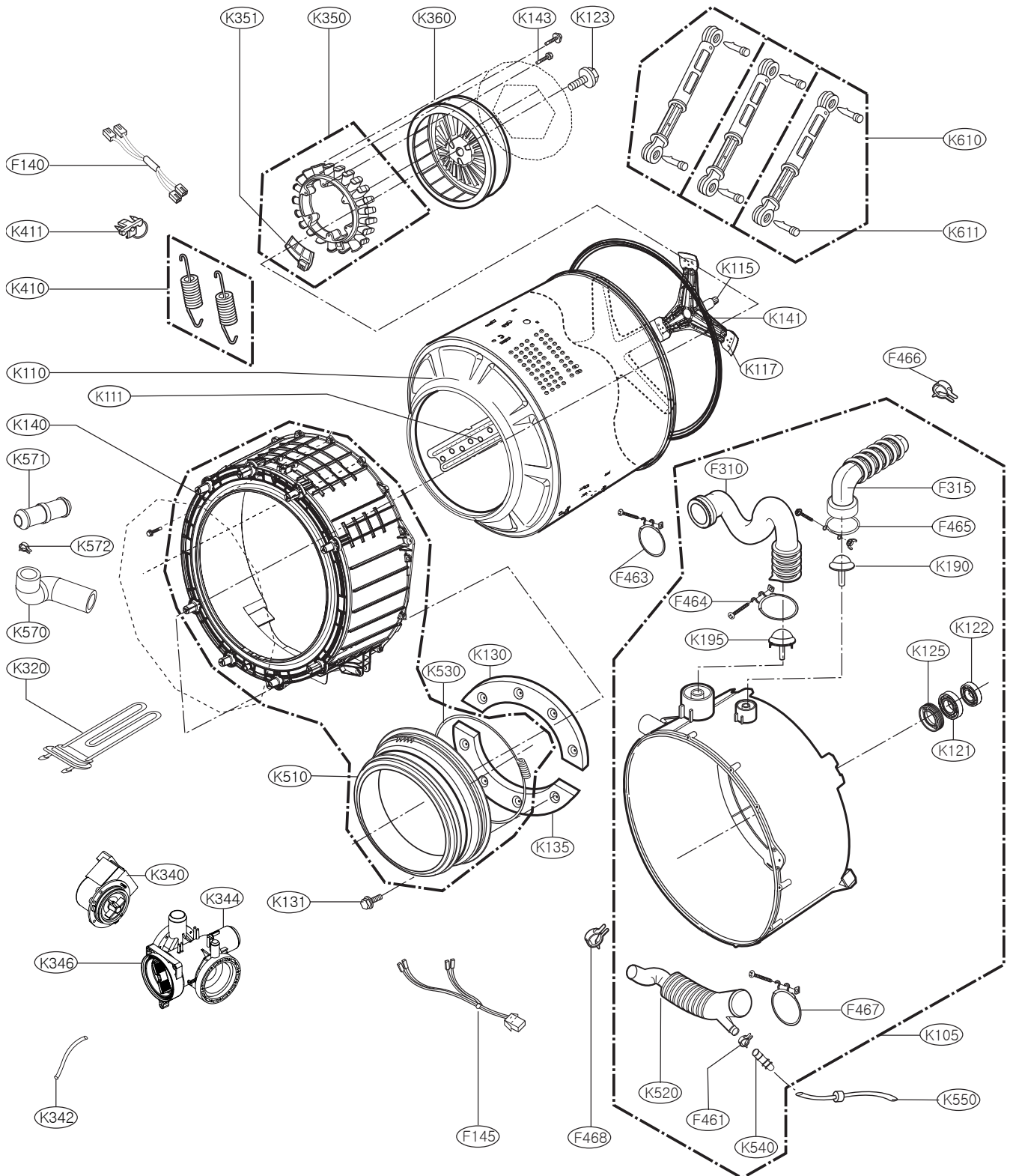

※ In case of replacing THERMISTOR of HEATER ASSEMBLY(K320), replace HEATER ASSEMBLY(K320), HEATER ASSEMBLY(K320) includes THERMISTOR.

※ In case of replacing BEARING,BALL(K121,K122) and GASKET(K105), replace TUB ASSEMBLY, OUTER(K105), TUB ASSEMBLY, OUTER(K105) includes BEARING,BALL(K121,K122) and GASKET(K125).

11-3. DISPENSER ASSEMBLY

