

# Hamilton Beach®

## *Big Mouth™ Juice Extractor*

READ BEFORE USE

## *Centrifugeuse Big Mouth™*

LIRE AVANT L'UTILISATION

## *Extractor de jugo Big Mouth™*

LEA ANTES DE USAR

Le invitamos a leer cuidadosamente este instructivo antes de usar su aparato.

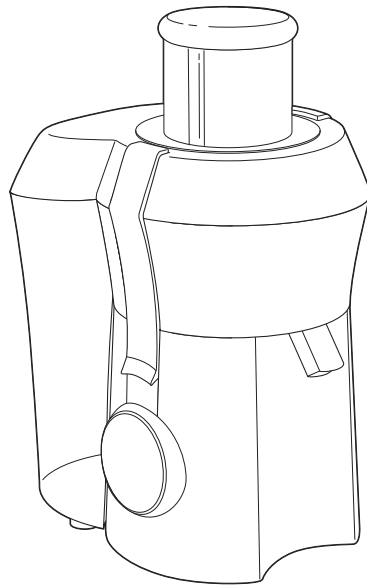

<b>English.....</b>	<b>2</b>
<b>USA: 1-800-851-8900</b>	
Visit <a href="http://hamiltonbeach.com">hamiltonbeach.com</a> for delicious recipes and to register your product online!	
<b>Français .....</b>	<b>15</b>
<b>Canada : 1-800-267-2826</b>	
Consulter <a href="http://hamiltonbeach.ca">hamiltonbeach.ca</a> pour des recettes délicieuses et pour enregistrer votre produit !	
<b>Español .....</b>	<b>30</b>
<b>México: 01 800 71 16 100</b>	
Visite <a href="http://hamiltonbeach.com">hamiltonbeach.com</a> para recetas deliciosas y para registrar su producto en línea.	

## IMPORTANT SAFEGUARDS

When using electrical appliances, basic safety precautions should be observed, including the following:

1. Read all instructions before operating.
2. To protect against risk of electrical shock, do not immerse cord, plug, or motor base in water or other liquid.
3. This appliance is not intended for use by children. Close supervision is necessary when this appliance is used near children. Do not allow children to use this appliance.
4. Always turn appliance OFF and unplug cord from outlet when not in use, before putting on or taking off parts, and before cleaning.
5. Avoid contacting moving parts. Keep fingers out of feed chute.
6. Never feed food by hand – always use the food pusher.
7. Always make sure the juice extractor is properly and completely assembled before the motor is turned on. The unit will not turn ON unless properly assembled. Do not release safety locking arm while juice extractor is in operation.
8. Never operate without pulp container in place.
9. Be sure to turn switch to OFF position after each use of your juice extractor. Make sure the motor stops completely before disassembling.
10. Do not put fingers or other objects into the juice extractor feed chute while it is in operation. If food becomes lodged in the opening, use food pusher to push it down. When this method is not possible, turn the motor off, unplug the cord from the outlet, and disassemble juicer to remove the remaining food.
11. Do not operate any appliance with a damaged cord or plug, or after the appliance malfunctions or is dropped or damaged in any manner. Call our toll-free customer service number for information on examination, repair or electrical or mechanical adjustment.
12. The use of attachments not recommended or sold by the appliance manufacturer may cause fire, electric shock, or injury.
13. Do not use outdoors.
14. Do not let cord hang over edge of table or counter, or touch hot surfaces, including stove.
15. Do not leave juice extractor unattended while it is operating.
16. Blades are sharp; handle carefully. Do not touch the small cutting blades in the base of the stainless steel strainer basket.
17. Keep hair, clothing, and jewelry, as well as spatulas and other utensils, away from feed chute during operation to prevent the possibility of severe injury to persons and/or damage to the appliance.
18. Do not use the appliance if the rotating strainer basket is damaged.
19. Always use the juice extractor on a dry, level surface.
20. Any maintenance other than cleaning should be performed by an authorized service center.
21. To reduce the risk of personal injury and/or damage to the appliance, do not use bent, dented or otherwise damaged strainer basket.

## SAVE THESE INSTRUCTIONS!

## Other Consumer Safety Information

**⚠ WARNING** **Cut or Crush Hazard.**

Extra-wide feed chute. Do not place hands or fingers down feed chute. Always use the food pusher. Failure to follow this instruction can result in serious personal injury.

**This appliance is intended for household use only.**

**CAUTION: This appliance is not intended for use by children.**

**WARNING! Shock Hazard:** This appliance has a polarized plug (one wide blade) that reduces the risk of electric shock. The plug fits only one way into a polarized outlet. Do not defeat the safety purpose of the plug by modifying the plug in any way or using an adaptor. If the plug does not fit, reverse the plug. If it still does not fit, have an electrician replace the outlet.

The length of the cord used on this appliance was selected to reduce the hazards of becoming tangled in, or tripping over, a longer cord. If a longer cord is necessary, an approved extension cord may be used. The electrical rating of the extension cord must be equal to or greater than the rating of the appliance. Care must be taken to arrange the extension cord so that it will not drape over the countertop or tabletop where it can be pulled on by children or accidentally tripped over.

The electrical rating of this appliance is listed on the bottom panel of the unit.

**The strainer basket is a delicate screen.** If bent or damaged, do not use, as it could break into small pieces and cause personal injury and/or damage the appliance. Call our toll-free customer service number to order a new basket. Replace basket when it shows signs of wear.

# Parts and Features

**⚠ WARNING**

Micro Mesh Strainer Basket may fly apart during use if it is damaged, resulting in the risk of cuts and bruises.

To reduce the risk of personal injury:

- Always inspect Micro Mesh Strainer Basket before each use.
- Never use a cracked, bent or damaged Micro Mesh Strainer Basket.

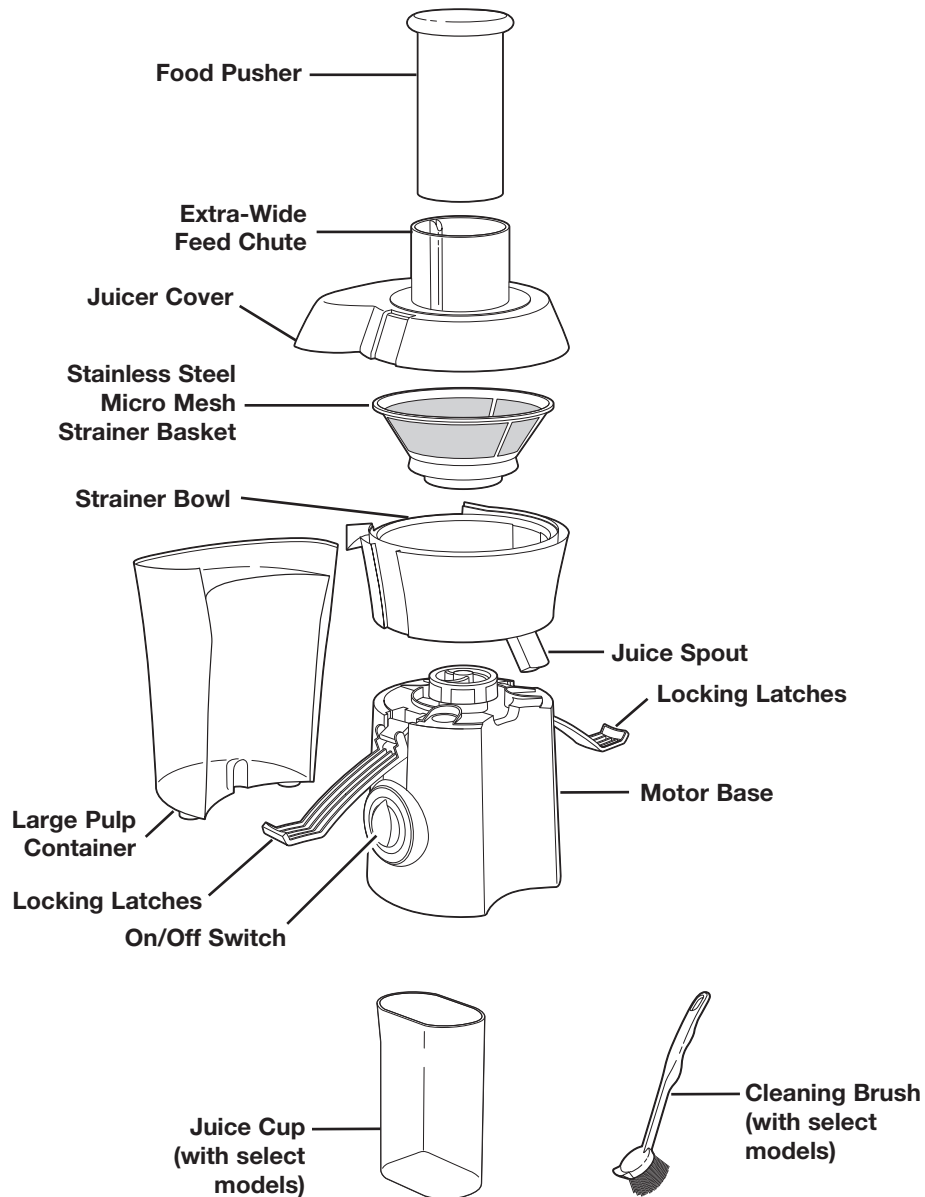

# How to Assemble

Read and follow instructions in "Before First Use."

## Before First Use

After unpacking the juice extractor, remove cardboard from filter basket and wash everything except the base in warm, soapy water. Rinse and dry immediately. Never immerse the base in water or other liquids; wipe it with a damp sponge.

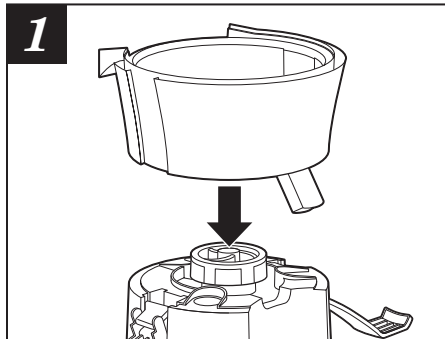

1 Place Strainer Bowl on top of the Motor Base.

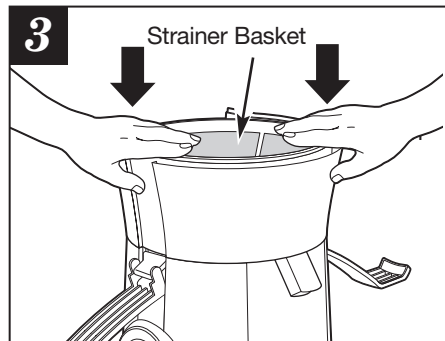
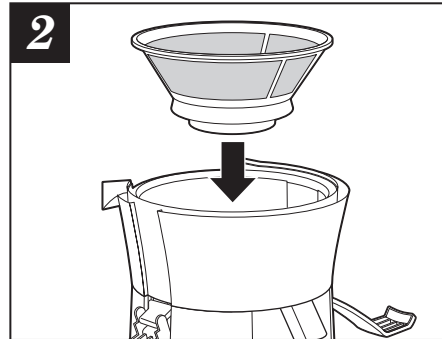

3 Place the Stainless Steel Strainer Basket inside the Strainer Bowl. With hands on outer edge, press Strainer Basket down firmly to latch into position.

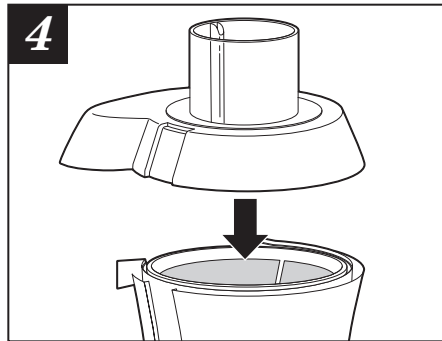

4 Place the Juicer Cover over the Strainer Bowl, positioning the Feed Chute over the Strainer Basket and lower into position.

(continued on next page)

## How to Assemble *(cont.)*

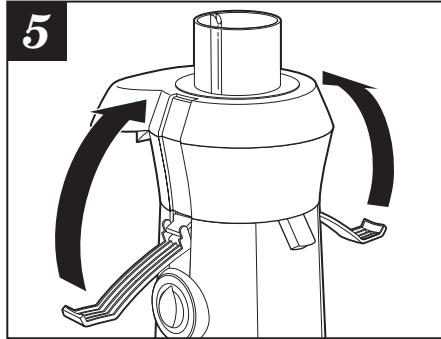

**5** Raise the Locking Latches up to lock into place.

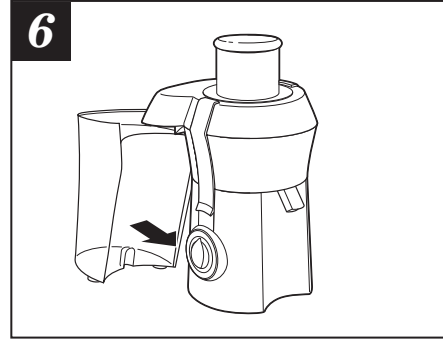

**6** Place the Pulp Container into position by tilting the Container slightly.

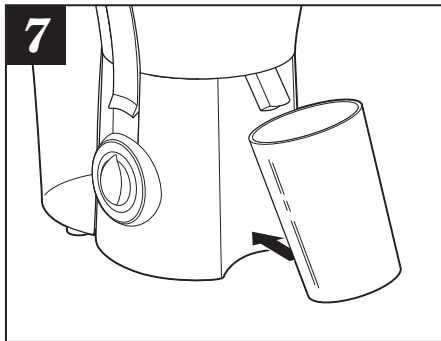

**7** Place a glass or other container under the Juice Spout.

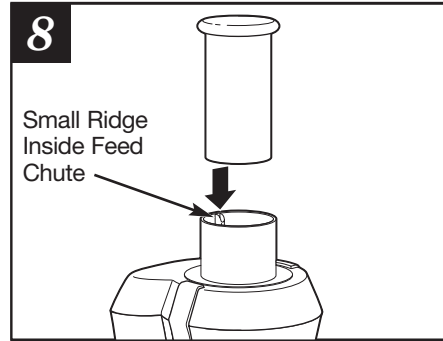

**8** Slide the Food Pusher down the Feed Chute by aligning the groove in the Food Pusher with the small ridge on the inside of the top of the Feed Tube.

### *Hint!*

To minimize clean-up, place a plastic grocery bag in the Pulp Container to collect the pulp. (See page 7 for more information.)

# How to Use

**⚠ WARNING Laceration Hazard.**

Never use fingers to push food down the Feed Chute or to clear the Feed Chute. Always use the Food Pusher provided.

**1** Wash fruits and vegetables.  
**NOTE:** Most fruits and vegetables such as apples, carrots, and cucumbers will not need to be cut since they will fit into Feed Chute whole. It is recommended that fruits or vegetables, such as oranges, melons, or mangoes, are peeled before placing in unit to minimize impact on juice flavor.

**3** Plug cord into 120 volt AC outlet. Turn ON/OFF Switch to ON.

**2** Ensure that unit is correctly assembled (see pages 5 and 6) and place a glass or container under spout.

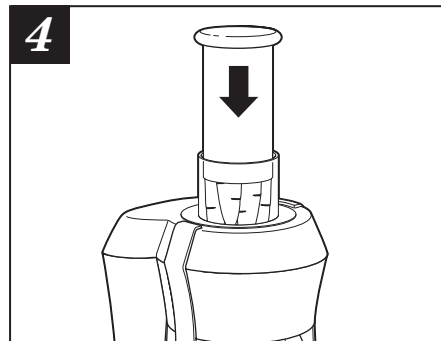

With the motor running, place food down the Feed Chute. Using Food Pusher, gently guide food down Feed Chute. **To extract the maximum amount of juice, always push Food Pusher down slowly.**

**5** Juice will flow into glass and separated pulp will accumulate in Pulp Container.  
**NOTE:** Pulp Container can be emptied during juicing by turning juice extractor OFF and then carefully removing Pulp Container. (Replace empty Pulp Container before continuing to juice.)



To minimize clean-up, place a plastic grocery bag in Pulp Container to collect pulp. When juicing is completed, simply remove grocery bag containing pulp.

**NOTE: Do not allow Pulp Container to overfill as this may prevent correct operation or damage the unit.**

## How to Disassemble

**1** Turn juice extractor OFF and unplug. Allow Strainer Basket to stop turning.

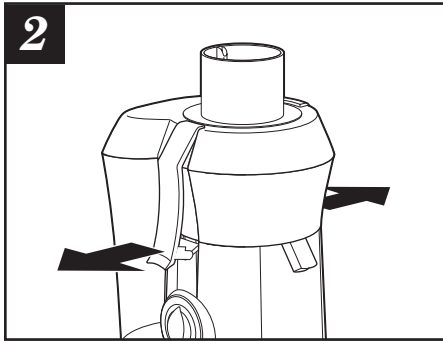

Release Locking Latches.

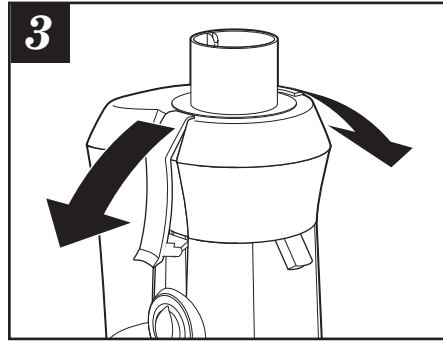

Move the Locking Latches down.

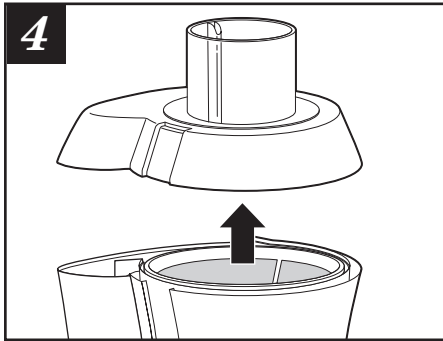

Lift off the Cover.

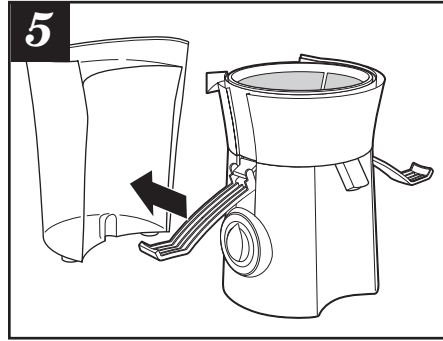

Remove the Pulp Container by sliding away from Motor Base.

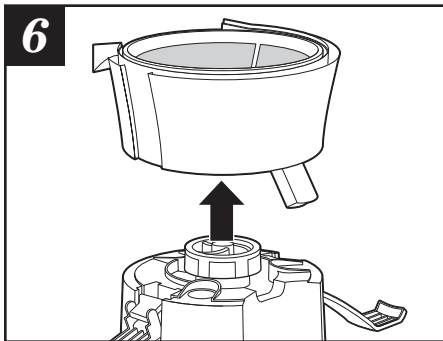

Lift off the Strainer Bowl with the Strainer Basket still in place.

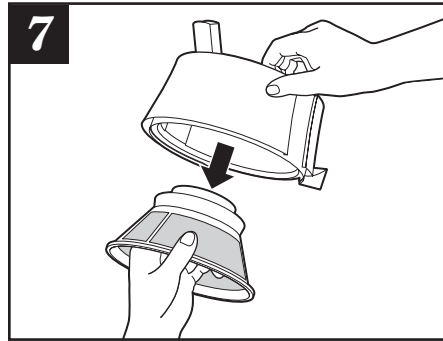

To remove the Strainer Basket, turn the Strainer Bowl upside down and carefully remove the Strainer Basket. (It is recommended to remove the Strainer Basket over a sink.)



## Care and Cleaning

**⚠ WARNING Shock Hazard.**

Do not immerse Motor Base in water or any other liquid.

- After disassembling the unit (see page 8) all removable parts may be washed in hot, soapy water.
- All plastic parts of the juice extractor can be placed in the bottom or top rack of the dishwasher. **Do not** place the Motor Base in the dishwasher. Some part distortion may occur if your household dishwasher's temperature is higher than normal or if the parts are placed too close to the heating element.
- Wipe the Motor Base with a damp cloth.

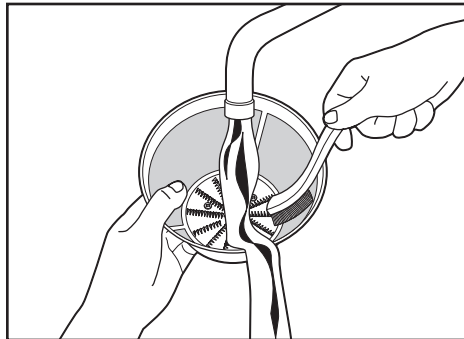

- The cleaning brush included with the unit is the most effective way to clean the Strainer Basket. Using the brush, hold the Strainer Basket under running water and brush inside and outside of the basket. Always treat the Strainer Basket with care; it can be easily damaged.

- Discoloration of the plastic may occur with some fruit and vegetables. To help prevent this, wash all parts immediately after use.

**NOTE:**

- To assist with cleaning, soak the Strainer Basket in hot, soapy water for approximately 10 minutes immediately after juicing is completed. If pulp is left to dry on the basket it may clog the fine pores of the filter mesh thereby lessening the effectiveness of the juice extractor.

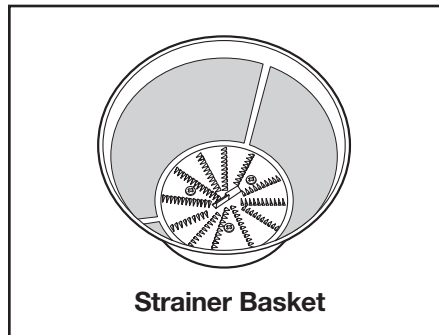

**CAUTION! Laceration Hazard.**

The center of the strainer basket contains small, sharp blades to process fruits and vegetables during the juicing function.

**Do not touch blades when handling the strainer basket.**

# Troubleshooting

POSSIBLE PROBLEM	EASY SOLUTION
Machine will not work when switched "ON."	The Locking Latches may not be correctly engaged. Check to see if the Locking Latches are properly positioned in the two grooves on either side of the Juice Cover. Refer to pages 5 and 6, Steps 4 and 5.
Motor appears to stall when juicing.	<p>The juicing action may be too vigorous. Try slower juicing action by pushing the Food Pusher down more slowly. Refer to page 7, Step 4.</p> <p>Wet pulp can build up under the Juicer Cover or Pulp Container. Turn unit OFF and unplug. Empty the Pulp Bin then clean Juice Cover and Strainer Basket.</p>
Excess pulp building up in the Micro Mesh strainer basket.	Turn OFF and unplug. Remove strainer basket and clean mesh walls with a fine brush. This will remove excess fiber build-up which could be inhibiting the juice flow. Refer to pages 8 and 9.
Pulp is too wet and insufficient juice is produced.	<p>Try a slower juicing action.</p> <p>Turn OFF and unplug. Remove strainer basket and clean mesh walls with a fine brush. This will remove excess fiber build-up which could be inhibiting the juice flow. Refer to pages 8 and 9.</p>
Juice sprays out of spout.	Try a slower juicing action by pushing the Food Pusher down more slowly. Refer to page 7, Step 4.
Juice drips out of spout immediately after juicing.	With motor ON, raise and lower Food Pusher in Feed Chute several times. The action forces remaining pulp and juice out of Strainer Bowl.
Machine vibrates excessively.	Build up of pulp in mesh of strainer basket. Turn unit OFF and unplug. Clean strainer basket. Refer to page 9. After cleaning, if machine vibration continues this could be a sign of a damaged Strainer Basket. Call our toll-free Customer Service number to order a new Strainer Basket.

# *Juicing Tips and Techniques*

## **Purchasing and Storing Fruits & Vegetables**

- Always wash fruits and vegetables before juicing.
- Always use fresh fruits and vegetables for juicing.
- To save money and obtain fresher produce, purchase fruits or vegetables that are in season.
- Keep your fruits and vegetables ready for juicing by washing them before storing.
- Most fruits and hardier type vegetables can be stored at cool room temperature. The more delicate and perishable items such as tomatoes, berries, leafy greens, celery, cucumbers and herbs should be stored in the refrigerator until required.

## **Preparing Fruits & Vegetables**

- It is recommended that fruits or vegetables, such as oranges, melons, or mangoes, are peeled before placing in juice extractor to minimize impact on juice flavor.
- All fruits with pits and large seeds such as nectarines, peaches, apricots, plums and cherries **MUST** be pitted before juicing.

### *Hint!*

Your juice extractor makes invigorating, frothy orange juice. Simply peel the oranges and juice. For best results, refrigerate oranges before juicing.

## **Using The Pulp**

- The remaining pulp left after juicing fruits or vegetables is mostly fiber and cellulose which, like the juice, contains vital nutrients necessary for the daily diet and can be used in many ways. However, like the juice, pulp should be used that day to avoid loss of vitamins.
- There are a number of recipes that use pulp. You can also use pulp to thicken casseroles or soups.
- Pulp is great used in the garden for compost.

## **Soy Milk, Almond Milk, and Rice Milk**

Your juice extractor may be used to make soy milk, almond milk and rice milk. One cup of soybeans, almonds or rice must be soaked in four cups of water for 24-48 hours in the refrigerator. Slowly pour one cup of the soaked mixture at a time into the food chute. The liquid extracted from the soaked mixture is the "milk."

### **NOTES:**

- Almonds must be soaked 24-48 hours before juicing.
- Soy milk should be boiled to improve the flavor.
- Vanilla, honey and sugar may be added to enhance the flavor of each milk type.

# Recipes

The following drink recipes yield a single serving of 6 to 10 ounces (175-300 ml). If sugar or honey is listed, add to juice after juicing.

## Two Can Mango

¼-inch (6 mm) slice fresh ginger  
½ mango  
¼ fresh pineapple, peeled

## An Antioxidant a Day...

½ cup (125 ml) cranberries  
½ cup (125 ml) raspberries  
½ cup (125 ml) strawberries  
½ cup (125 ml) white grapes  
1 teaspoon (5 ml) honey

## Mr. Bone's

¼ small head cabbage  
1 celery stalk  
1 apple

## Vitamin C Zing

3 oranges, peeled  
⅛-inch (3 mm) slice fresh ginger

## Calcium Builder

¼ small head cabbage  
1-2 fresh basil leaves  
1 stalk broccoli  
(3-4 flowerets with stalk)  
1 celery stalk  
1 apple

## Teacher's Pet

1 apple  
1 tangerine, peeled

## Healthy Women

2 broccoli flowerets with stalk  
¼ green pepper  
1 carrot  
1 celery stalk  
1 tomato  
Tabasco sauce to taste

## Y Zone

8 medium tomatoes  
1 lemon, peeled  
1 stalk celery  
1 medium carrot  
1 slice of onion  
1 teaspoon (5 ml) Worcestershire  
½ teaspoon salt (2.5 ml)

## Eye Opener

2 carrots  
1 apple  
1 tangerine, peeled

## Winter Blue Zing

2 apples  
¼ cup (60 ml) blueberries  
1 orange, peeled

## Good Morning!

½ ruby red grapefruit, peeled  
1 pear  
1 banana, peeled  
1 cup white grapes

## Liquid Fire

1 medium tomato  
½ jalapeno pepper  
1 handful parsley  
½ cucumber

### **For Your Eyes Only**

---

2 carrots  
½ yellow squash  
1 pear

### **Healthy Men**

---

1 medium tomato  
3 sprigs of asparagus  
1 stalk of celery  
½ yellow squash

### **X Zone**

---

1 handful romaine lettuce  
1 handful alfalfa sprouts  
1 carrot  
2 handfuls spinach  
1 stalk celery

### **vitAmin**

---

1 tomato  
½ cucumber  
½ bunch parsley  
1 carrot

### **Orchard Blend**

---

2 apples  
2 pears

### **Vineyard Hop**

---

1 cup (250 ml) grapes  
1 pear

### **The Health Club**

---

½ of a 6-ounce (170 g) bag spinach  
3 carrots

### **Passion Potion**

---

1 pear  
2 apples  
Small piece gingerroot

### **Sour Grapes**

---

1 lime, peeled  
2 cups red grapes

### **The Fiber Press**

---

2 apples  
½ lemon, peeled

## Customer Service

If you have a question about your juice extractor, call our toll-free customer service number. Before calling, please note the model, type, and series numbers and fill in that information below. These numbers can be found on the bottom of your juice extractor. This information will help us answer your question much more quickly.

**MODEL:** \_\_\_\_\_ **TYPE:** \_\_\_\_\_ **SERIES:** \_\_\_\_\_

**This warranty applies to products purchased in the U.S. or Canada.**

### LIMITED WARRANTY

This product is warranted to be free from defects in material and workmanship for a period of one (1) year from the date of original purchase, except as noted below. During this period, we will repair or replace this product at our option.

THE FOREGOING WARRANTY IS IN LIEU OF ANY OTHER WARRANTY OR CONDITION, WHETHER EXPRESS OR IMPLIED, WRITTEN OR ORAL INCLUDING, WITHOUT LIMITATION, ANY STATUTORY WARRANTY OR CONDITION OF MERCHANTABILITY OR FITNESS FOR A PARTICULAR PURPOSE. ANY LIABILITY IS EXPRESSLY LIMITED TO AN AMOUNT EQUAL TO THE PURCHASE PRICE PAID, AND ALL CLAIMS FOR SPECIAL, INCIDENTAL AND CONSEQUENTIAL DAMAGES ARE HEREBY EXCLUDED.

There is no warranty with respect to the following, which may be supplied with this product, including without limitation: glass parts, glass containers, cutter/strainers, blades, seals, gaskets, clutches, motor brushes, and/or agitators, etc. This warranty extends only to the original consumer purchaser and does not cover a defect resulting from abuse, misuse, neglect including failure to clean product regularly in accordance with manufacturer's instructions, use for commercial purposes, or any use not in conformity with the printed directions.

This warranty gives you specific legal rights, and you may also have other legal rights which vary from state to state, or province to province. Some states or provinces do not allow limitations on implied warranties or special, incidental or consequential damages, so the foregoing limitations may not apply to you.

If you have a claim under this warranty, DO NOT RETURN THE APPLIANCE TO THE STORE! Please call our CUSTOMER SERVICE NUMBER. (For faster service please have model, series, and type numbers ready for operator to assist you.)

### CUSTOMER SERVICE NUMBERS

In the U.S. 1-800-851-8900

In Canada 1-800-267-2826

[hamiltonbeach.com](http://hamiltonbeach.com)

**KEEP THESE NUMBERS FOR FUTURE REFERENCE!**