

This Owner's Manual is provided and hosted by [Appliance Factory Parts](#).



# LG 90448 Owner's Manual

[Shop genuine replacement parts for LG 90448](#)



[Find Your LG Dryer Parts - Select From 451 Models](#)

----- Manual continues below -----



Website:<http://www.sears.com>

# ELECTRIC & GAS DRYER SERVICE MANUAL

## CAUTION

READ THIS MANUAL CAREFULLY TO DIAGNOSE  
TROUBLES CORRECTLY BEFORE OFFERING SERVICE.

**MODEL : 796.8044\*.900 / 796.8044\*.900  
796.9044\*.900 / 796.9044\*.900**



AUG. 2009 PRINTED IN KOREA

P/No.:MFL62119909

## IMPORTANT SAFETY NOTICE

The information in this service guide is intended for use by individuals possessing adequate backgrounds of electrical, electronic, and mechanical experience. Any attempt to repair a major appliance may result in personal injury and property damage. The manufacturer or seller cannot be responsible for the interpretation of this information, nor can it assume any liability in connection with its use.

### **WARNING !**

*To avoid personal injury, disconnect power before servicing this product. If electrical power is required for diagnosis or test purposes, disconnect the power immediately after performing the necessary checks.*

## RECONNECT ALL GROUNDING DEVICES

If grounding wires, screws, straps, clips, nuts, or washers used to complete a path to ground are removed for service, they must be returned to their original position and properly fastened.

## WHAT TO DO IF YOU SMELL GAS:

- *Do not try to light a match, or cigarette, or turn on any gas or electrical appliance.*
- *Do not touch any electrical switches. Do not use any phone in your building.*
- *Clear the room, building or area of all occupants.*
- *Immediately call your gas supplier from a neighbor's phone. Follow the gas supplier's instructions carefully.*
- *If you cannot reach your gas supplier, call the fire department.*

## IMPORTANT

Electrostatic Discharge (ESD)  
Sensitive Electronics

**ESD problems are present everywhere. ESD may damage or weaken the electronic control assembly. The new control assembly may appear to work well after repair is finished, but failure may occur at a later date due to ESD stress.**

- Use an anti-static wrist strap. Connect wrist strap to green ground connection point or unpainted metal in the appliance.

- OR -

**Touch your finger repeatedly to a green ground connection point or unpainted metal in the appliance.**

- Before removing the part from its package, touch the anti-static bag to a green ground connection point or unpainted metal in the appliance.
- Avoid touching electronic parts or terminal contacts; handle electronic control assembly by edges only.
- When repackaging failed electronic control assembly in anti-static bag, observe above instructions.

---

# CONTENTS

1. SPECIFICATIONS .....	4
2. FEATURES AND BENEFITS .....	5
3. INSTALLATION INSTRUCTIONS .....	6
4. COLUMBUS DRYER CYCLE PROCESS .....	9
5. COMPONENT TESTING INFORMATION .....	10
6. MOTOR DIAGRAM AND SCHEMATIC.....	13
7. CONTROL LAY - OUT .....	14
8. WIRING DIAGRAM .....	15
9. STEAM FUNCTION .....	16
9-1. STEAM CYCLE GUIDE .....	16
9-2. TROUBLESHOOTING FOR STEAM DRYER .....	17
9-3. DISPLAY FAULT/ERROR CODES FOR STEAM DRYER .....	17
10. DIAGNOSTIC TEST .....	18
10-1. TEST 1 120VAC ELECTRICAL SUPPLY .....	19
10-2. TEST 2 THERMISTOR TEST --- MEASURE WITH POWER OFF .....	22
10-3. TEST 3 MOTOR TEST .....	23
10-4. TEST 4 MOISTURE SENSOR .....	24
10-5. TEST 5 DOOR SWITCH TEST .....	25
10-6. TEST 6 HEATER SWITCH TEST - ELECTRIC TYPE.....	26
10-7. TEST 7 GAS VALVE TEST - GAS TYPE.....	27
11. CHANGE GAS SETTING (NATURAL GAS, PROPANE GAS) .....	28
12. DISASSEMBLY INSTRUCTIONS .....	30
13. EXPLODED VIEW .....	40
13-1. CONTROL PANEL & PLATE ASSEMBLY .....	40
13-2. PANEL DRAWER ASSEMBLY & GUIDE ASSEMBLY .....	41
13-3. CABINET & DOOR ASSEMBLY .....	42
13-4-1. DRUM & MOTOR ASSEMBLY : ELECTRIC TYPE .....	43
13-4-1. DRUM & MOTOR ASSEMBLY : GAS TYPE .....	44

## 1

## SPECIFICATIONS

ITEM		796.8044*.900 / 796.8044*.900 / 796.9044*.900 / 796.9044*.900	REMARK
Material & Finish	Color	White / Patina Beige	
	Top Plate	Spray	
	Door Trim	Light Gray	
POWER SUPPLY		120V / 240V 60Hz (26A)	
ELECTRICITY CONSUMPTION	MOTOR	250W (4.5A)	AC 120V
	HEATER	5400W (22.5A)	AC 240V ( ELECTRIC TYPE)
	LAMP	15W (125mA)	AC 120V
	GAS VALVE	13W (110mA) X 2	AC 120V ( GAS TYPE)
CONTROL TYPE		Electronic	
DRUM CAPACITY		7.3 cu.ft.	
Weight (lbs): Net/Gross		126 / 144	
No. of Programs		9	
No. of Dry Option		5	
No. of Temperature Controls		5	
No. of Dry Levels		5	
Audible End of Cycle Beeper		High / Low / Off	
Sensor	Moisture	Equipped	Electro sensor
	Temperature	Equipped	Thermistor
Reversible Door		Adopted	
Drum		Double Coated Steel	
Dryer Rack		Equipped	
Child lock		Equipped	
Interior Light		Equipped	
Product (WXHXD)		27" x 38" x 28 1/3"	
Packing (WXHXD)		29 1/2" x 44 3/4" x 30 3/4"	

# 2

## FEATURES AND BENEFITS

- Apply Model : 796.8044\*.900 / 796.8044\*.900 /  
796.9044\*.900 / 796.9044\*.900

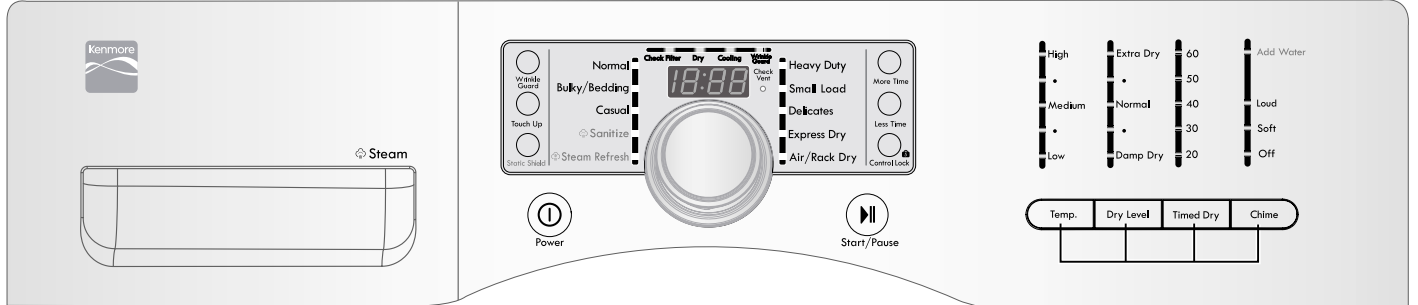

# 3

# INSTALLATION INSTRUCTIONS

## 3-1. POWER CORD

### 1) 4-wire connection

**IMPORTANT: A 4-wire connection is required for mobile homes and where local codes do not permit the use of 3 wire connections.**

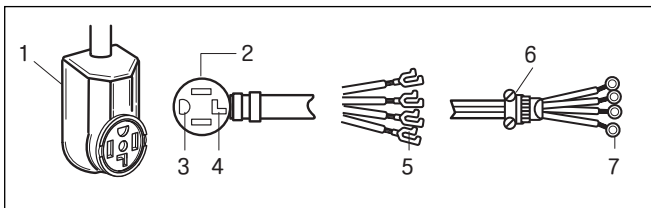

1. 4-wire receptacle (NEMA type 14-30R)
2. 4-prong plug
3. Ground prong
4. Neutral prong
5. Spade terminals with upturned ends
6. 3/4 in. (1.9 cm) UL approved strain relief
7. Ring terminals

1. Remove center terminal block screw.
2. Remove appliance ground wire (green) from external ground connector screw. Fasten it under center, silver colored terminal block screw.

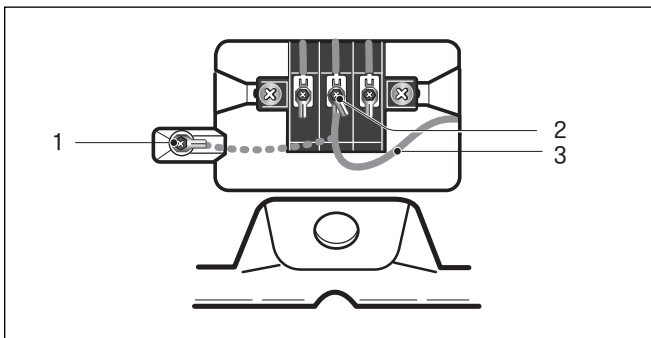

1. External ground connector - Dotted line shows position of NEUTRAL ground wire before being moved to center terminal block screw
2. Center silver-colored terminal block screw
3. Green wire of harness

3. Connect ground wire (green or bare) of power supply cable to external ground conductor screw. Tighten screw.
4. Connect neutral wire (white or center wire) of power supply cord to the center, silver colored terminal screw of the terminal block.

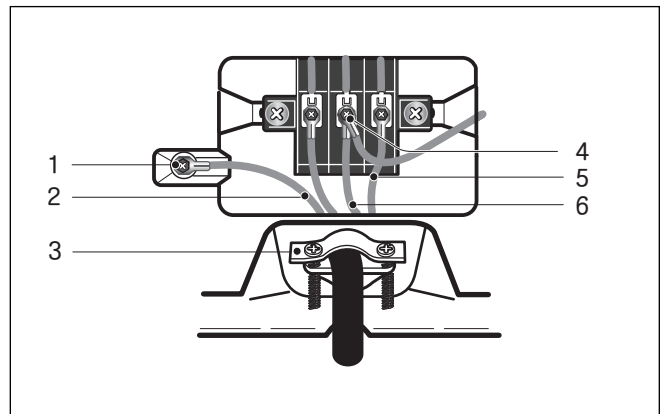

1. External ground connector
  2. Green or bare copper wire of power supply cord
  3. 3/4 in. (1.9 cm) UL-listed strain relief
  4. Center silver-colored terminal block screw
  5. Neutral grounding wire (green)
  6. Neutral wire (white)
5. Connect the other wires to outer terminal block screws. Tighten screws.
  6. Tighten strain relief screws.
  7. Insert tab of terminal block cover into slot of dryer rear panel. Secure cover with hold-down screw.

## 2) 3-wire connection

Use where local codes permit connecting cabinet-ground conductor to neutral wire.

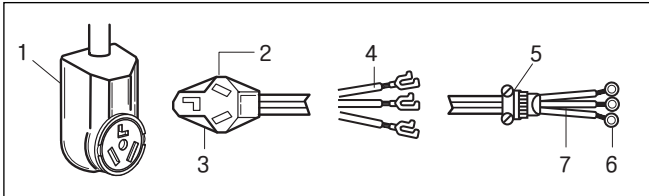

1. 3-wire receptacle (NEMA type 10-30R)
2. 3-wire plug
3. Neutral prong
4. Spade terminals with up turned ends
5. 3/4 in. (1.9 cm) UL approved strain relief
6. Ring terminals
7. Neutral (white or center wire)

1. Loosen or remove center terminal block screw.
2. Connect neutral wire (white or center wire) of power supply cord to the center, silver colored terminal screw of the terminal block. Tighten screw.

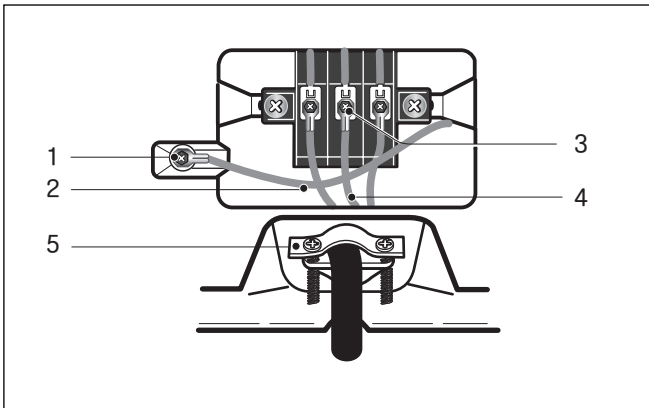

1. External ground connector
2. Neutral grounding wire (green)
3. Center silver-colored terminal block screw
4. Neutral wire (white or center wire)
5. 3/4 in. (1.9 cm) UL-listed strain relief

3. Connect the other wires to outer terminal block screws. Tighten screws.
4. Tighten strain relief screws.
5. Insert tab of terminal block cover into slot of dryer rear panel. Secure cover with hold-down screw.

## 3) Optional 3-wire connection

Use where local codes permit connecting cabinet-ground conductor to neutral wire.

1. Remove center terminal block screw.
2. Remove appliance ground wire (green) from external ground connector screw. Connect appliance ground wire and the neutral wire (white or center wire) of power supply cord/cable under center, silver colored terminal block screw. Tighten screw.
3. Connect the other wires to outer terminal block screws. Tighten screws.

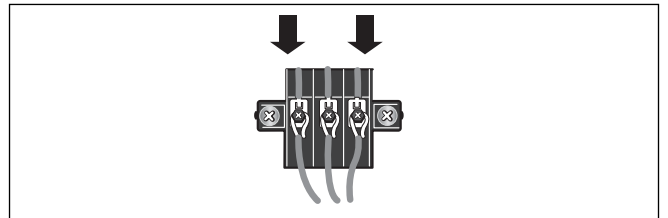

4. Tighten strain relief screws.
5. Insert tab of terminal block cover into slot of dryer rear panel. Secure cover with hold-down screw.
6. Connect a separate copper ground wire from the external ground connector screw to an adequate ground.

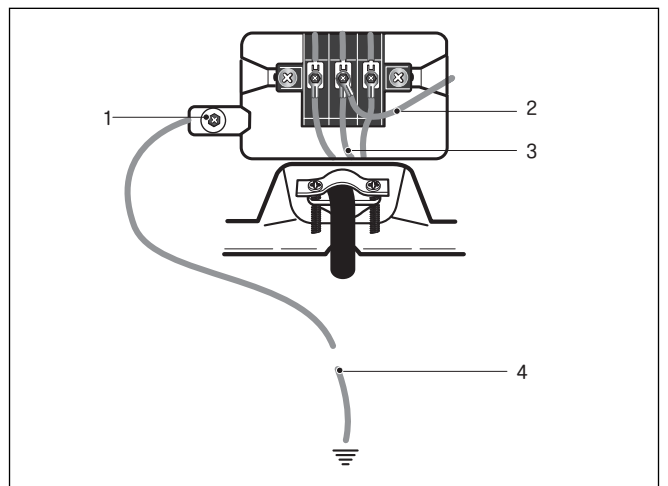

1. External ground connector
2. Neutral grounding wire (green)
3. Neutral wire (white or center wire)
4. Grounding path determined by a qualified electrician

## 3-2. Connect Gas Supply Pipe (Gas Dryer ONLY)

For further assistance, refer to section on **Gas Requirements**.

1. Make certain your dryer is equipped for use with the type of gas in your laundry room. Dryer is equipped at the factory for Natural Gas with a 3/8" N.P.T. gas connection.
2. Remove the shipping cap from the gas connection at the rear of the dryer. Make sure you do not damage the pipe thread when removing the cap.
3. Connect to gas supply pipe using a new flexible stainless steel connector.
4. Tighten all connections securely. Turn on gas and check all pipe connections (internal & external) for gas leaks with a non-corrosive leak detection fluid.
5. For L.P. (Liquefied Petroleum) gas connection, refer to section on Gas Requirements.

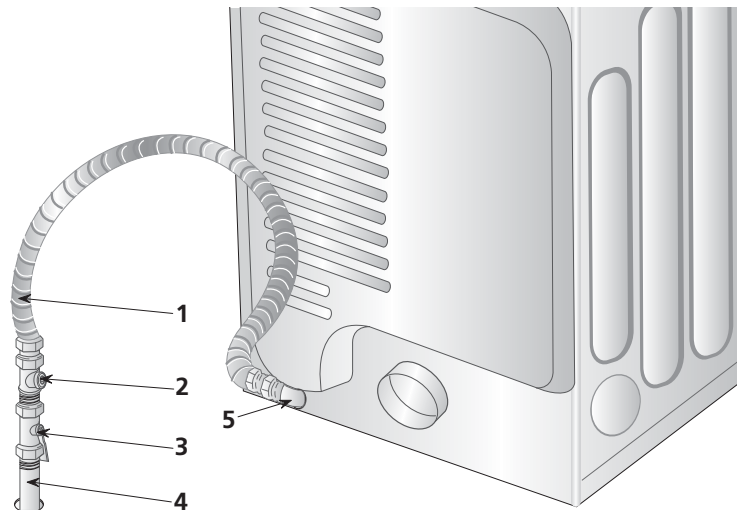

- 1 New Stainless Steel Flexible Connector - Use only if allowed by local codes (Use Design A.G.A. Certified Connector)
- 2 1/8" N.P.T. Pipe Plug (for checking inlet gas pressure)
- 3 Equipment Shut-Off Valve-Installed within 6' (1.8 m) of dryer

- 4 Black Iron Pipe  
Shorter than 20' (6.1 m) - Use 3/8" pipe  
Longer than 20' (6.1 m) - Use 1/2" pipe
- 5 3/8" N.P.T. Gas Connection

# 4

## DRYER CYCLE PROCESS

■ Apply Model : 796.8044\*.900 / 796.9044\*.900

Cycle		Default			Conditions of operation and termination				
		Temperature	Dry Level	Display Time	Drying		Cooling		Wrinkle care
					Electro-sensor	Temp-Control	Default time	Temp-Control**	Time
Sensor Dry *	Steam Refresh	Mid High	(Extra dry)	20 min	Saturation	64±5°C	(5min)	(47±5°C)	90 min
	Steam Sanitize	Extra High	(Extra dry)	70 min	Saturation	68±5°C	(5min)	(47±5°C)	
	Heavy duty	Extra High	(Normal)	54 min	Saturation	68±5°C	(5min)	(47±5°C)	
	Bulky/Bedding	Medium	(Normal)	55 min	Saturation	60±5°C	(5min)	(47±5°C)	
	Normal	Medium	(Normal)	41 min	Saturation	60±5°C	(5min)	(47±5°C)	
	Casual	LOW	(Normal)	36 min	Saturation	55±5°C	(5min)	(38±5°C)	
	Delicates	LOW	(Normal)	32 min	Saturation	55±5°C	(5min)	(38±5°C)	
	Small Load	Extra High	(Normal)	30 min	Saturation	68±5°C	(5min)	(47±5°C)	
Manual Dry **	Express Dry	Extra High	—	33 min	Saturation	68±5°C	(5min)	(47±5°C)	90 min
	Touch Up	Mid High	—	25 min	Saturation	66±5°C	(5min)	(47±5°C)	
	Air / Rack dry	—	—	50 min	Saturation	No Heater	NA	NA	
Load		Motor							
		Heater			Temperature Control for each cycle				

\* Sensor dry : “Dry Level” is set by users.

\*\* Manual dry : “Temperature control” is set by users.

Default settings can be adjusted by users.

# 5

# COMPONENT TESTING INFORMATION

**CAUTION** When checking the Component, be sure to turn the power off, and do voltage discharge sufficiently.

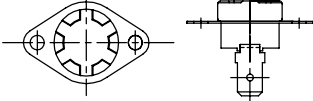
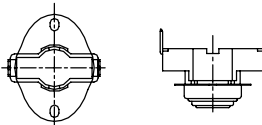
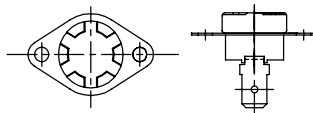
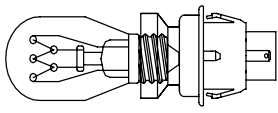
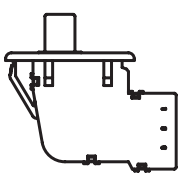
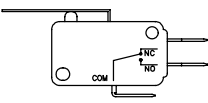
Component	Test Procedure	Check result	Remark
1. Thermal cut off  • Check Top Marking : N130	Measure resistance of terminal to terminal ① Open at $284 \pm 12^{\circ}\text{F}$ ( $140 \pm 7^{\circ}\text{C}$ ) ② Auto reset $-31^{\circ}\text{F}$ ( $-35^{\circ}\text{C}$ ) Same shape as Outlet Thermostat.	If thermal fuse is open must be replaced ① Resistance value $\approx \infty$ ② Continuity ( $250^{\circ}\text{F} \downarrow$ ) $< 1\Omega$	<ul style="list-style-type: none"> <li>• Heater case-Safety</li> <li>• Electric type</li> </ul>
2. Hi limit Thermostat (Auto reset) 	Measure resistance of terminal to terminal ① Open at $257 \pm 9^{\circ}\text{F}$ ( $125 \pm 5^{\circ}\text{C}$ ) ② Close at $221 \pm 9^{\circ}\text{F}$ ( $105 \pm 5^{\circ}\text{C}$ )	① Resistance value $\approx \infty$ ② Resistance value $< 5\Omega$	<ul style="list-style-type: none"> <li>• Heater case - Hi limit</li> <li>• Electric type</li> </ul>
3. Outlet Thermostat (Auto reset)  • Check Top Marking : N85	Measure resistance of terminal to terminal ① Open at $185 \pm 9^{\circ}\text{F}$ ( $85 \pm 5^{\circ}\text{C}$ ) ② Close at $149 \pm 9^{\circ}\text{F}$ ( $65 \pm 5^{\circ}\text{C}$ ) Same shape as Thermal cut off.	① Resistance value $\approx \infty$ ② Resistance value $< 5\Omega$	<ul style="list-style-type: none"> <li>• Blow housing - Safety</li> <li>• Electric type</li> </ul>
4. Lamp holder 	Measure resistance of terminal to terminal	Resistance value : $80\Omega \sim 100\Omega$	
5. Door switch 	Measure resistance of the following terminal 1) Door switch knob : open ① Terminal : "COM" - "NC" (1-3) ② Terminal : "COM" - "NO" (1-2) 2) Door switch push : push ① Terminal : "COM" - "NC" (1-3) ② Terminal : "COM" - "NO" (1-2)	① Resistance value $< 1\Omega$ ② Resistance value $\approx \infty$ ① Resistance value $\approx \infty$ ② Resistance value $< 1\Omega$	The state that Knob is pressed is opposite to Open condition.
6. Idler switch 	Measure resistance of the following terminal : "COM - NC"	1. lever open ① Resistance value $< 1\Omega$ 2. Lever push (close) ② Resistance value $\approx \infty$	

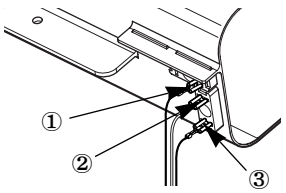
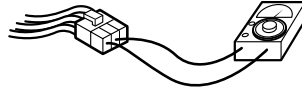
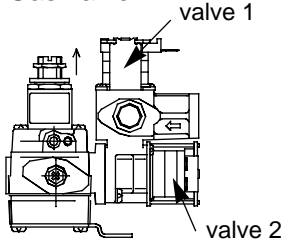
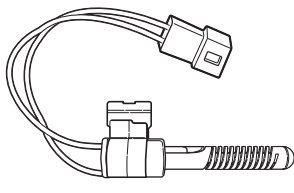
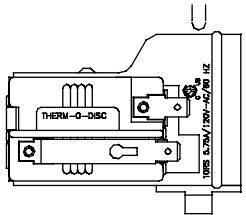
Component	Test Procedure	Check result	Remark
7. Heater 	Measure resistance of the following terminal ① Terminal : 1 (COM) - 2 ② Terminal : 1 (COM) - 3 ③ Terminal : 2 - 3	① Resistance value : 10Ω ② Resistance value : 10Ω ③ Resistance value : 20Ω	<ul style="list-style-type: none"> <li>• Electric type</li> </ul>
8. Thermistor 	Measure resistance of terminal to terminal Temperature condition : 58°F ~ (10~40°C) 58°F ~ 104F (10~40°C)	Resistance value : 10Ω	<ul style="list-style-type: none"> <li>• Heater case - Hi limit</li> <li>• Electric type</li> </ul>
9. Motor			<ul style="list-style-type: none"> <li>• See Page 13</li> </ul>
10. Gas valve 	Measure resistance of the following terminal ① Valve 1 terminal ② Valve 2 terminal	① Resistance value : > 1.5kg ~ ② Resistance value : > 1.5~2.5kg	<ul style="list-style-type: none"> <li>• Gas type</li> </ul>
11. Igniter 	Measure resistance of terminal to terminal	Resistance value : 100~800Ω	<ul style="list-style-type: none"> <li>• Gas type</li> </ul>
12. Frame Detect 	Measure resistance of terminal to terminal ① Open at 370°F ((Maximum) ② Close at 320°F	① Resistance value ≒ ∞ ② Resistance value < 1Ω	<ul style="list-style-type: none"> <li>• Gas type</li> </ul>

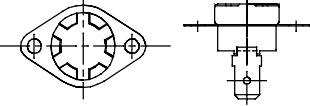
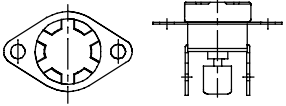
Component	Test Procedure	Check result	Remark
<p>13. Hi-limit Thermostat (Auto reset)</p>  <p>• Check Top Marking : N95</p>	<p>Measure resistance of terminal to terminal</p> <p>① Open at <math>203 \pm 7^{\circ}\text{F}</math> (<math>95 \pm 5^{\circ}\text{C}</math>) ② Close at <math>158 \pm 9^{\circ}\text{F}</math> (<math>70 \pm 5^{\circ}\text{C}</math>)</p>	<p>① Resistance value <math>\approx \infty</math> ② Continuity <math>&lt; 1\Omega</math></p>	<ul style="list-style-type: none"> <li>• Gas type</li> <li>• Gas funnel- Hi-limit</li> </ul>
<p>13. Thermal Cut off (Manual reset)</p>  <p>• Check Top Marking : N110</p>	<p>Measure resistance of terminal to terminal</p> <p>① Open at <math>230 \pm 12^{\circ}\text{F}</math> (<math>110 \pm 7^{\circ}\text{C}</math>) ② Manual reset</p>	<p>If thermal fuse is open must be replaced</p> <p>① Resistance value <math>\approx \infty</math> ② Continuity <math>&lt; 1\Omega</math></p>	<ul style="list-style-type: none"> <li>• Gas type</li> <li>• Gas funnel- Safety</li> </ul>

# 6

# MOTOR DIAGRAM AND SCHEMATIC

**NOTE** When checking Component, be sure to turn Power off, then do voltage discharge sufficiently.

■ Contact On / Off by Centrifugal Switch

Terminal No		①	②	③	④	⑤	⑥	Remark
Mode	Resistance							
Motor STOP	2 ~ 3Ω				●	●		Motor
	≒ ∞	●	●					Heater (Electric Models)
	≒ ∞			●			●	Gas Valve (Gas Models)
Motor RUN	3 ~ 5Ω				●	●		Motor
	< 1Ω	●	●					Heater (Electric Models)
	< 1Ω			●			●	Gas Valve (Gas Models)

..... Open  
 ——— Close

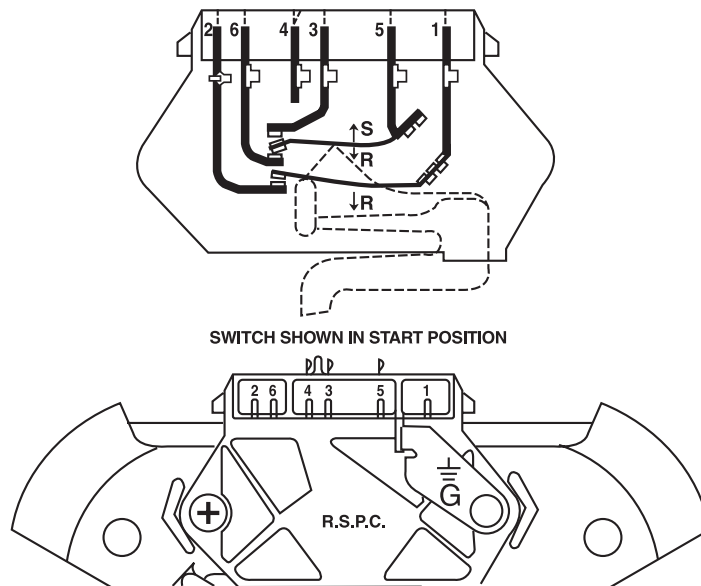

■ STOP MODE  
 (When Motor does not operate)

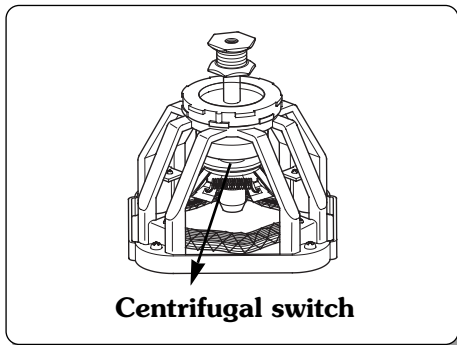

■ RUN MODE  
 (Motor operates)

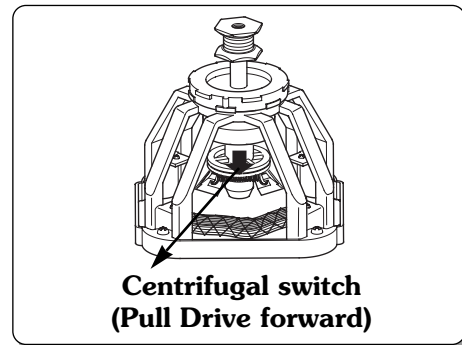

# 7

# CONROL LAY - OUT

## PWB ASSEMBLY DISPLAY LAY-OUT

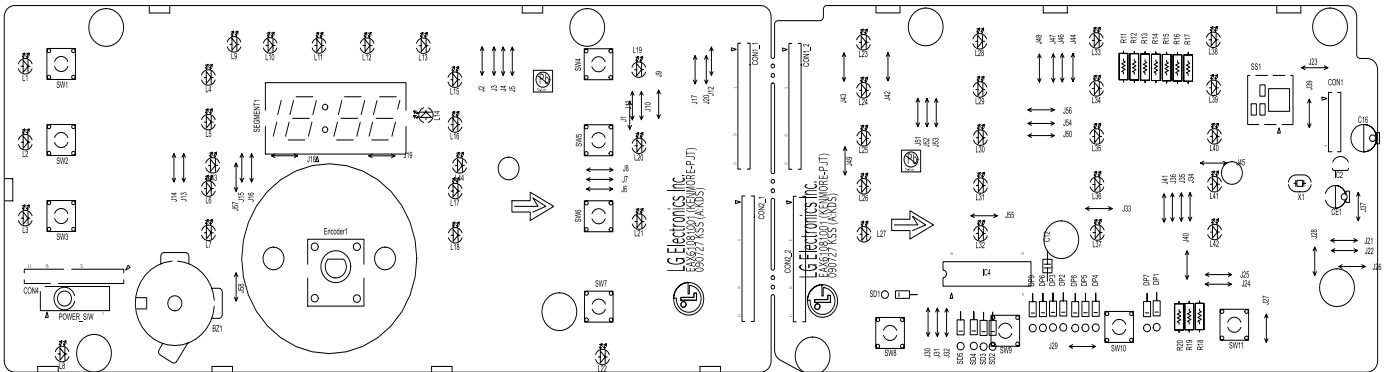

## PWB ASSEMBLY LAY-OUT

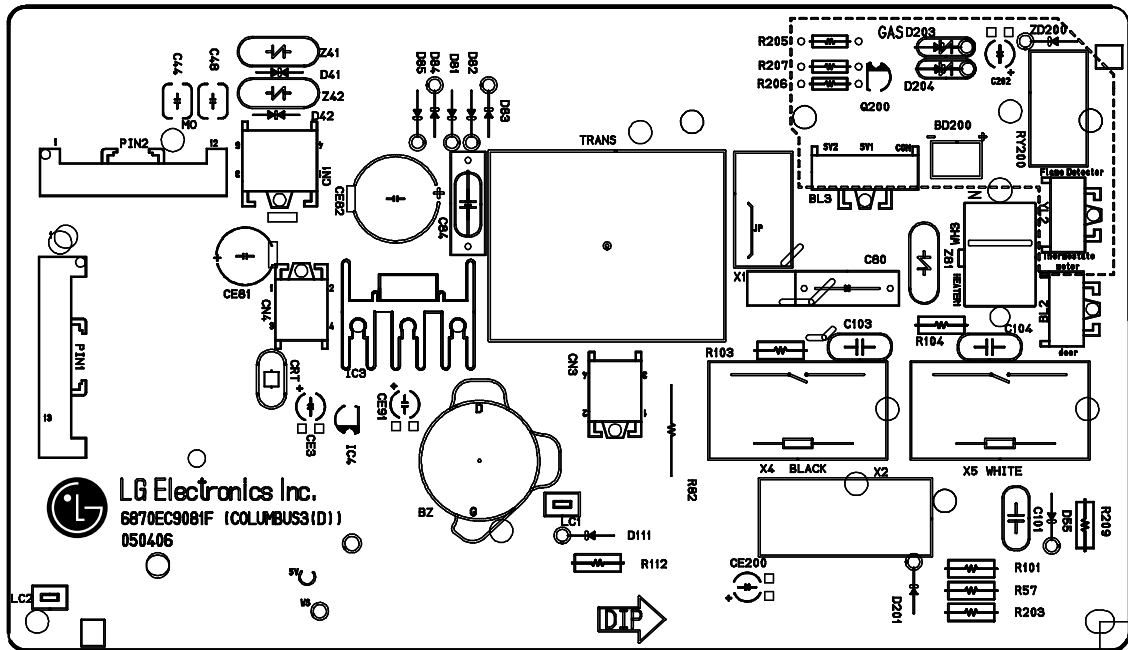

**CAUTION**

*Label all wires prior to disconnection when servicing controls. Wiring errors can cause improper and dangerous operation. Verify proper operation after servicing.*

## ELECTRIC DRYER WIRING DIAGRAM

■ Apply Model : 796.8044\*.900 / 796.8044\*.900

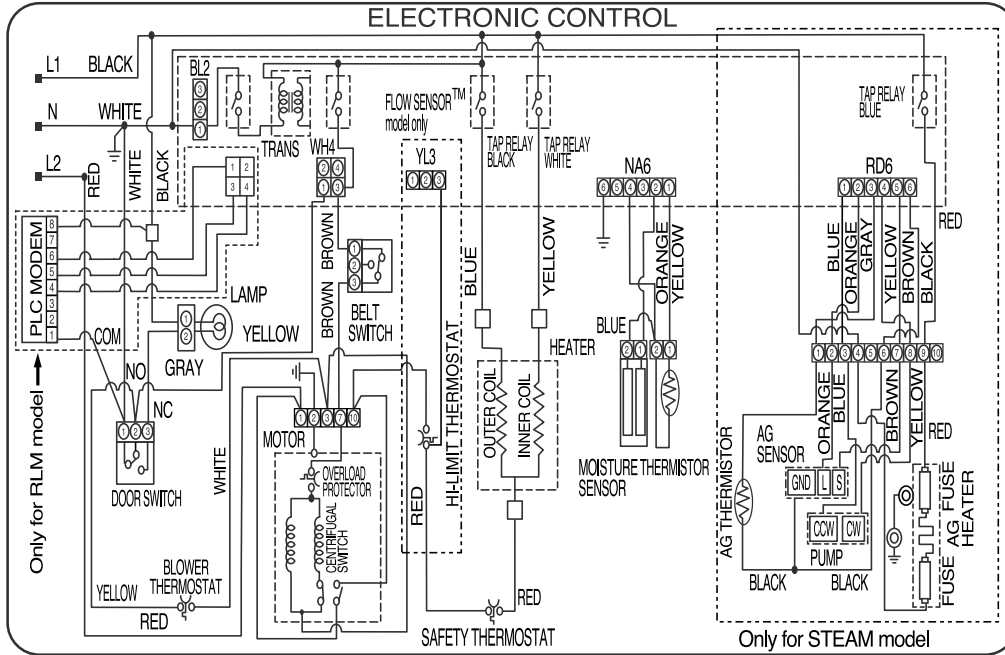

## GAS DRYER WIRING DIAGRAM

■ Apply Model : 796.9044\*.900 / 796.9044\*.900

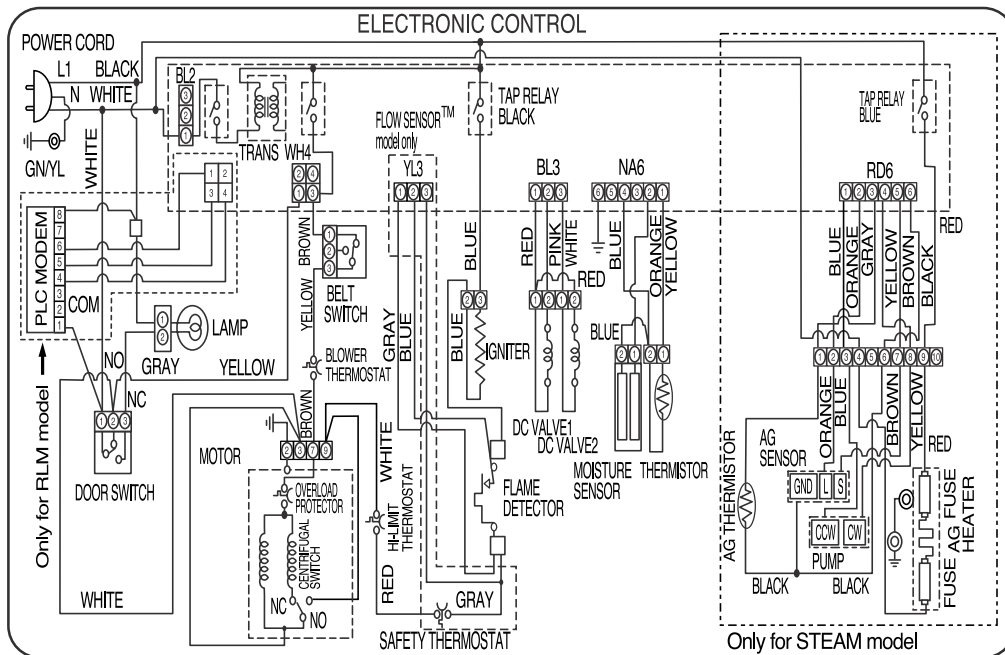

## 9-1. Steam Cycle Guide

	STEAM	DEFAULT TIME	TEMP. CONTROL	DRY LEVEL	FABRIC STATE	FABRIC TYPE	MAXIMUM AMOUNT
<b>STEAM SANITIZE</b>		39 minutes			Dry	Comforter Bedding Children's clothing	Single (1 each) 3 lbs.
<b>STEAM REFRESH</b>		20 minutes	●		Dry	Comforter Shirts*	Single (1 each) 5 each
	+ <b>REDUCE STATIC</b>	10 minutes Only reduce static			Dry	Shirts*	8 lbs. (18 Items.)
<b>NORMAL BULKY/BEDDING HEAVY DUTY CASUAL, DELICATES SMALL LOAD</b>	+ <b>REDUCE STATIC</b>	Follow selected cycle		●	Wet	Follow selected cycle	8 lbs. (18 Items.)
<b>TIMED DRY</b>	+ <b>REDUCE STATIC</b>	45 minutes	●		Wet	Follow selected temp	8 lbs. (18 Items.)

**IMPORTANT NOTES ABOUT STEAM CYCLES:**

- \* The steam feeder must be filled with water up to the MAX line. Otherwise, an error message will be displayed.
- \* If the lint filter or exhaust duct is clogged, the Steam options will not give proper results.
- \* For best results, load articles of similar size and fabric type.  
Do not overload.
- \* Water only - Do not add any additives or other materials as these will damage your dryer.
- \* Before moving the dryer, make sure the steam feeder is empty.
- \* Best results are obtained with cotton/poly blend fabrics.

## 9-2. Troubleshooting for Steam Dryer

PROBLEM	POSSIBLE CAUSES	SOLUTIONS
Water drips from nozzle when Steam Cycle starts.	<ul style="list-style-type: none"> <li>This is normal.</li> </ul>	<ul style="list-style-type: none"> <li>This is steam condensation. The dripping water will stop after a short time.</li> </ul>
The drum does not turn during Steam Cycle.	<ul style="list-style-type: none"> <li>This is normal.</li> </ul>	<ul style="list-style-type: none"> <li>The drum is turned off and only tumbles intermittently so that the steam vapor remains in the drum.</li> </ul>
Can not see steam vapor at the beginning of cycle.	<ul style="list-style-type: none"> <li>This is normal.</li> </ul>	<ul style="list-style-type: none"> <li>Steam is released at different stages of the cycle for each option. Steam will not normally be visible, although condensation may form on the inside of the door.</li> </ul>
The display shows: <i>bl 9</i>	<ul style="list-style-type: none"> <li>MORE TIME pressed.</li> </ul>	<ul style="list-style-type: none"> <li>Pressing the MORE TIME button adjusts the load size from 1 to 5 articles or a big load indicated by <i>bl 9</i> in the display.</li> </ul>
Steam is not visible during Steam Cycle.	<ul style="list-style-type: none"> <li>This is normal.</li> </ul>	<ul style="list-style-type: none"> <li>Steam vapor is difficult to see when the door is closed, although condensation may form on the inside of the door.</li> </ul>
Top plate of the dryer is very warm.	<ul style="list-style-type: none"> <li>This is normal.</li> </ul>	<ul style="list-style-type: none"> <li>Top plate gets very warm during steam operation.</li> </ul>

## 9-3. Display Fault/Error Codes for Steam Dryer

The error codes below will be displayed when attempting to start a drying cycle, or after activating the Diagnostic Test mode.

DISPLAY	CHECKING PART	CAUSE	REMARK
tE4	Thermistor of steam generator	Steam generator thermistor open or shorted.	<ul style="list-style-type: none"> <li>tE4 error is only displayed in the test mode.</li> <li>Replace the steam generator.</li> </ul>
E1	Steam generator	Steam generator temperature exceeds 116 deg for more than 3 seconds. Steam hose or nozzle is clogged.	<ul style="list-style-type: none"> <li>Check the hose and nozzle for clogging.</li> <li><b>CAUTION:</b> The hose and nozzle will be extremely hot during and immediately after steam operation.</li> </ul>
E3	Steam generator	Sensors do not detect that steam generator is full within 60 seconds.	<ul style="list-style-type: none"> <li>If water in the steam feeder is less than about 2/3 full, this error may be displayed. Fill the feeder and restart the cycle.</li> </ul>
E4	Steam generator	<ul style="list-style-type: none"> <li>Steam generator temperature does not rise 4°C every 2 minutes or the temperature is less than 80°C for 3 seconds after steam temperature has been reached.</li> </ul>	<ul style="list-style-type: none"> <li>Steam generator element is not heating and generator may need to be replaced.</li> </ul>
E5	Pump	When the AD value of the pump less than 10 in the test mode.	<ul style="list-style-type: none"> <li>E5 error is only displayed in the test mode.</li> <li>Replace the steam feeder pump.</li> </ul>

1. This TEST should be used for Factory test /Service test. Do not use this DIAGNOSTIC TEST other than specified.
2. Activating the Heater manually with the Door open may trip the Thermostat attached to the Heater, therefore do not activate it manually. (Do not press the door switch to operate the heater while the door is open )

## ■ ACTIVATING THE DIAGNOSTIC TEST MODE

1. UNIT must be in standby (unit plugged in, display off)
2. Press POWER while pressing MORE TIME and LESS TIME simultaneously.
3. Press START/PAUSE button to advance through diagnostics.

Pressing the START/PAUSE	CHECKING ACTION	DISPLAY	CHECKPOINT
None	Electric control & Temperature sensor	8E9(Elec Type) 898(Gas Type)	Standard
		V00	PGM Ver (8E8-V008E8)
		tE1	Thermistor open
		tE2	Thermistor shorted
		tE4	AG Thermistor open or shorted
Once	Motor+Controller	30 = Low moisture 239 = High moisture	Motor runs Displays Moisture Sensor Operation : If moisture sensor is contacted with damp cloth. The display number is below 180 in normal condition
Twice	<ul style="list-style-type: none"> <li>■ ELECTRIC TYPE Motor+Heater1(2700W)</li> <li>■ GAS TYPE Motor+Gas valve</li> </ul>	Current Temp. (5~70)	<ul style="list-style-type: none"> <li>■ ELECTRIC TYPE Heater 1 is energized - 2700 W</li> <li>■ GAS TYPE Valve runs (Temperature in the drum is displayed in degrees C.)</li> </ul>
3 times	<ul style="list-style-type: none"> <li>■ ELECTRIC TYPE Motor+Heater1+Heater2 (5400W)</li> <li>■ GAS TYPE Motor+Gas valve</li> </ul>	Current Temp. (5~70)	<ul style="list-style-type: none"> <li>■ ELECTRIC TYPE: Heater 1 and heater 2 are energized - 5400 W</li> <li>■ GAS TYPE: Gas valve is energized (Temperature in the drum is displayed in degrees C.)</li> </ul>
4 times	Motor+Pump+ Heater2(runs for 1sec) (Heater1 off)	11 = Low pump* 255 = High pump*	Pump runs
		E5	Pump Error
5 times	Motor,Pump,Heater2 off	OO	
6 times	Loads, Controller off		Power off

### \* To check pump operation:

When pressed 4 times in the test mode, If the AD value of the pump is higher than 10 on the display, the pump is normal. If it is lower than 10, E5 error will be displayed.

## ■ Test 1 120V AC Electrical supply

**NOTE:** To properly check power supply in case of floating neutral or high resistance connections, a load must be applied to the circuit. It is important that the power button be pressed while checking the voltages as described below.

With the dryer plugged in, press the POWER button to turn on dryer.

YES

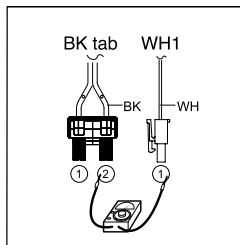

Check the voltage at the main PCB between WH1-1 (WH) and the black wire on the black tab relay. Is 120 VAC present while pressing the start button?

YES

- Replace main PCB.
- Replace display PCB.

NO

(NOTE: For gas dryers skip this step.)  
With the dryer plugged in, check the voltage at the terminal block between the neutral (WH) and L1 (BK) terminals. Is the voltage 120 VAC while pressing the START/PAUSE button?

NO

- Check power cord.
- Check terminal block connections.

YES

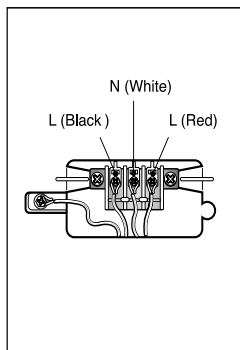

With the dryer plugged in, check the voltage at the power cord plug between the neutral and L1 (and L2 for electric dryers). Is the voltage 120 VAC while pressing the START/PAUSE button?

NO

- Check the power supply fuse or circuit breaker.
- Check the receptacle connections.

YES

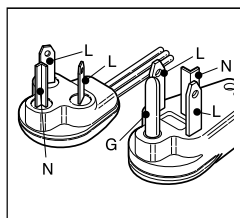

Replace the power cord.

<b>Caution</b>	When measuring power, be sure to wear insulated gloves, to and avoid an electric shock.
<b>Trouble Symptom</b>	Check the Tab Relays Connection properly.
<b>Measurement Condition</b>	With Dryer Power On; Connector linked to Controller.

## 1. Power Connection

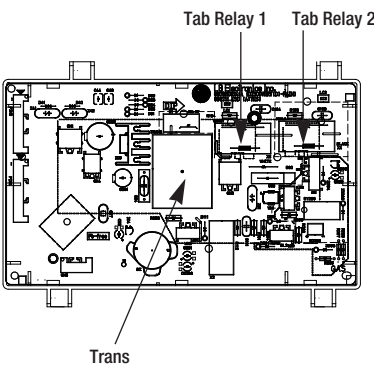

\* PCB ASSEMBLY LAYOUT

**< Table 1 > : Connection of the Tab Relay with Heater (Elec)**

	T	a	T	a	R
High Mid High Medium	on	on	on	on	Temperature Control below $68 \pm 4^\circ\text{C}$ . Turn on Heater1 and Heater2.
Low Extra Low	on	off	on	off	Temperature Control below $52 \pm 4^\circ\text{C}$ . Only Turn on Heater1.

**< Table 2 > : Connection of the Tab Relay with Burner (Gas)**

	T	a	B	R
High Mid High Medium	○	○	○	Temperature Control below $70 \pm 4^\circ\text{C}$ . Turn on Burner
Low Extra Low	○	○	○	Temperature Control below $47 \pm 4^\circ\text{C}$ . Turn on Burner

## 2. Status Mode Of The Connection

**< Table 1 > : Connection of Tab Relay with the Tab Relay of the PCB ASSEMBLY (Elec)**

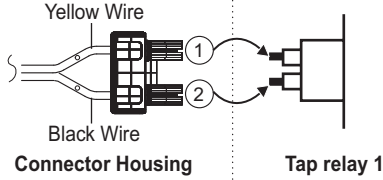
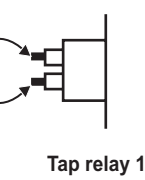
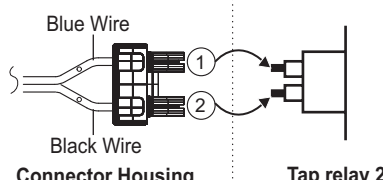
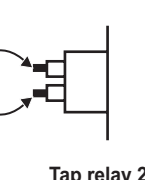
	Color	Connection		Remark
		Harness	PCB	
Connector Housing	Black			Check the Matching color Between Harness wire and Tab Relay. (Black Housing – Black Tab Relay)
	White			Check the Matching color Between Harness wire and Tab Relay. (White Housing – White Tab Relay)

< Table 2 > : Connection of Tab Relay with PCB ASSEMBLY (Gas)

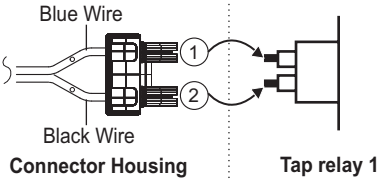
	Color	Harness	PCB	Remark
Connector Housing	Black	 <p>Blue Wire Black Wire Connector Housing Tap relay 1</p>		Check the Matching color Between Harness wire and Tab Relay. (Black Housing – Black Tab Relay)

### 3. Status Mode Of wrong Connection

< Table1 > : Wrong Connection of the Tab Relay and Connector Housing (Elec)

Items	Case	Heater1 Operation(black)	Heater2 operation(White)	PCB condition Of operation
1.Black and White Housing	Wire ①, ② CROSS	Off	Off	Power Off
2.Black Housing	Wire ①, ② CROSS	Off	Off	Power Off
3.White Housing	Wire ①, ② CROSS	Normal	Normal	Power On
* 4.Black and White Housing	Housing CROSS	Heater2	Heater1	Power On
5.Black and White Housing	Housing and Wire ①, ② CROSS	Off	Off	Power Off

< Table2 > : Wrong Connection of the Tab Relay and Connector Housing (Gas)

Items	Case	Heater1 Operation(black)	Heater2 operation(White)	PCB condition Of operation
1.Black and White Housing	Wire ①, ② CROSS	Off	Off	Power Off

### ⚠ CAUTION

- In case of power failure(<Table1>-1,2,5,<Table2>-1), Please check the Connection of "2.Status Table of Connection".  
In case of power failure(<Table1>-4), please check the Connection of "2. Status Table of Connection". Because improper Connection of the equipment-dryer can be damaged of changing heater.

## ■ Test 2 Thermistor Test---Measure with Power Off

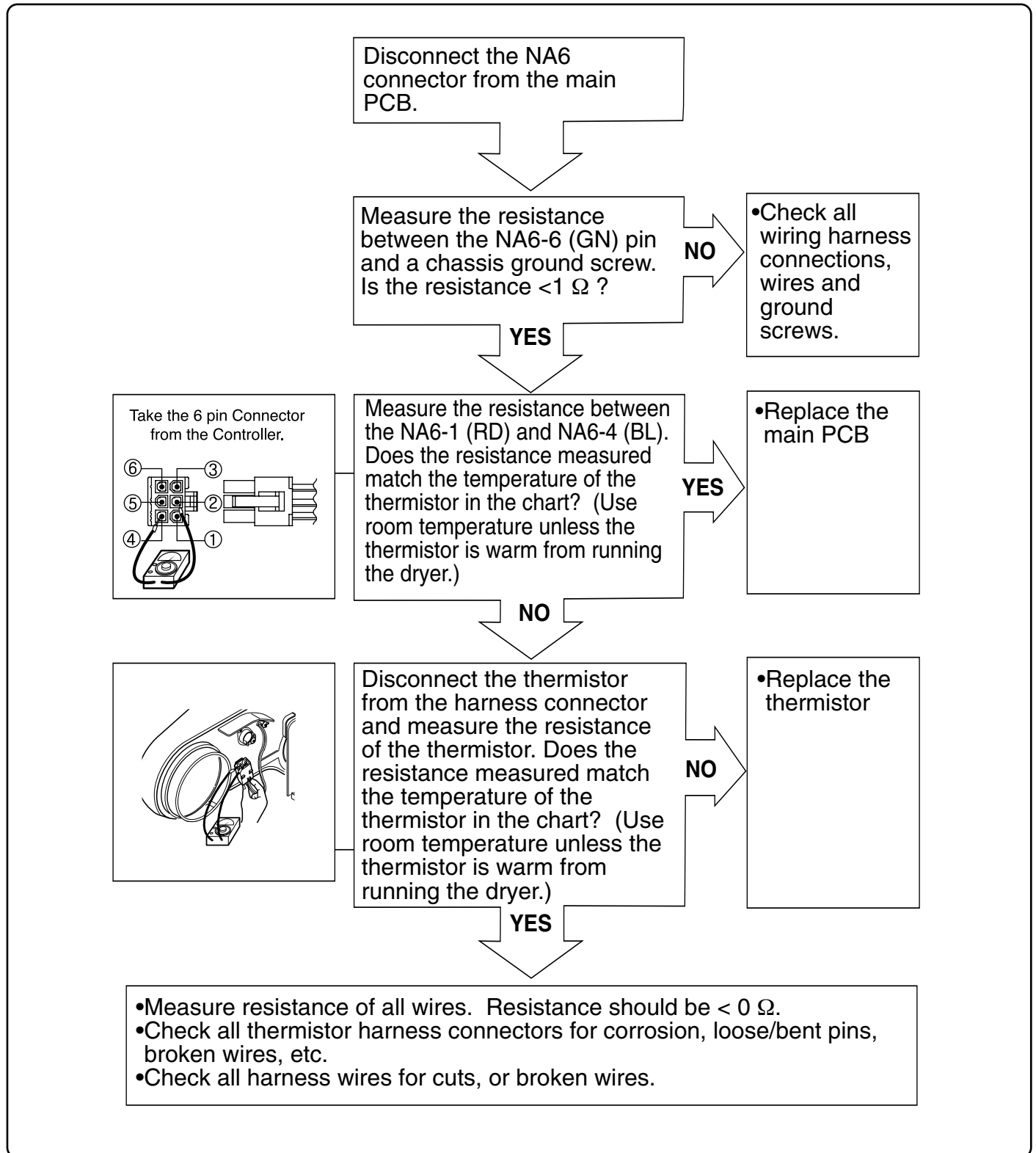

## Test 3 Motor test

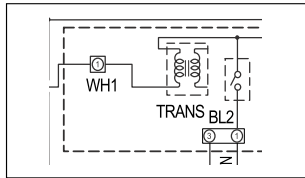

In diagnostic test mode, press the START / PAUSE button. Is the voltage 120 VAC between WH1-1(WH) and BL3-1 (BN)?

NO

- Replace main PCB

YES

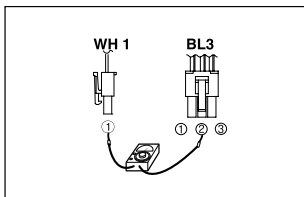

With the connectors disconnected, check the resistance between WH1-1 (WH) and BL3-2 (BN). Is the resistance 2-4  $\Omega$  ?  
\* Measure with the door closed.

YES

- Recheck voltage at main PCB and replace if no voltage.

NO

With the connectors disconnected, check the resistance between WH1-1 (WH) and BL3-3 (YL). Is the resistance 0  $\Omega$  ?  
\* Measure with the door closed.

NO

- Check door switch activation.
- Check wiring harness and connections.
- See DOOR SWITCH TEST #5.

YES

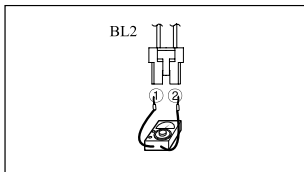

With the connectors disconnected, check the resistance between BL2-1 (BN) and BL3-3 (YL). Is the resistance 2-4  $\Omega$  ?  
\* Measure with the door closed.

YES

- Recheck voltage at main PCB and replace if no voltage.

NO

With the connectors disconnected, check the resistance between the terminals of the thermal fuse on the blower housing. Is the resistance 0  $\Omega$  ?

NO

- Replace the outlet thermal fuse.
- Check the thermistor (test # 3).
- Check exhaust system for restrictions.

YES

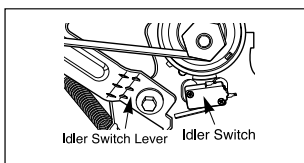

Is the arm of the idler pulley contacting the belt switch lever? (Normal operating position is NO CONTACT.)

YES

- Check idler pulley and arm.
- Check drum belt condition (stretched/broken)
- Check drum belt routing

NO

With the connectors disconnected, check the resistance between terminals 1 and 2 (N.O.) of the belt switch on the motor mount. Is the resistance <1  $\Omega$  with no switch contact?

NO

- Replace the belt switch.

YES

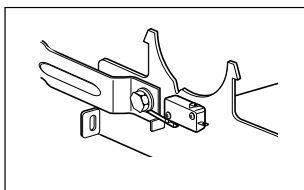

- Check Motor. (Refer to MOTOR DIAGRAM AND SCHEMATIC.)
- Check if control connector is plugged in.

## ■ Test 4 Moisture sensor

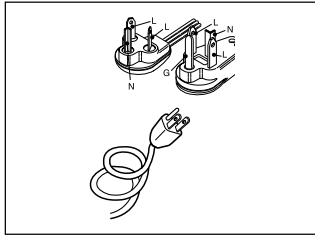

Disconnect the NA6 connector from the main PCB. Measure the resistance between the NA6-6 (GN) pin and a chassis ground screw. Is the resistance  $< 1 \Omega$  ?

NO

•Check all wiring harness connections, wires and ground screws.

YES

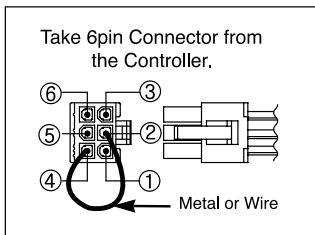

Put a jumper between NA6-2 (OR) and NA6-4 (BL) to create a circuit connection for the continuity test in the next step.

YES

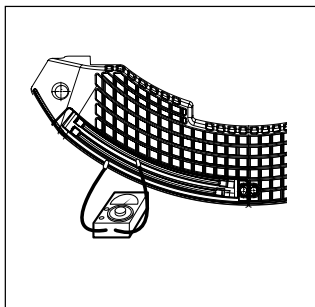

Measure the resistance between the two moisture sensor bars on the in the lint filter housing inside the drum. Is the resistance  $< 1 \Omega$ ?

YES

•Replace the main PCB.

NO

Check all connections and wires between the NA6 terminal at the main PCB and the sensor bars. Check the resistance is  $0\Omega$ .

YES

- Measure the resistance of all wires. Resistance should be  $< 1 \Omega$ .
- Check all sensor harness connectors for corrosion, loose/bent pins, broken wires, etc.
- Check all harness wires between the main PCB and the sensor for cuts, or broken wires.

## ■ Test 5 Door switch test

Disconnect the WH1 and BL3 connector from the main PCB. Measure the resistance between the NA6-6 (GN) pin and a chassis ground screw. Is the resistance  $< 1 \Omega$  ?

NO

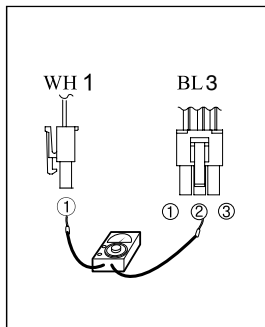

Disconnect the WH1 and BL3 connector from the main PCB. Measure the resistance between WH1-1 (WH) and BL3-3 (YL). Is the resistance  $< 1 \Omega$  with the door closed and  $\infty \Omega$  with the door open?

YES

•Replace the main PCB.

NO

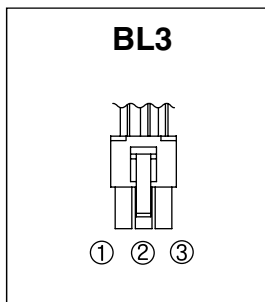

\*Skip this step if the dryer does not have a drum light. Disconnect the BL3 and the black tab relay connectors from the main PCB. Measure the resistance between BL3-3 (YL) and the BK wire on the black tab relay connector. Is the resistance  $< 1 \Omega$  with the door opened and  $\infty \Omega$  with the door closed?

NO

•Replace the light bulb.  
•Replace the light socket.

YES

Refer to the individual door switch and light bulb/socket component tests.

## ■ Test 6 Heater switch test - Electric Type

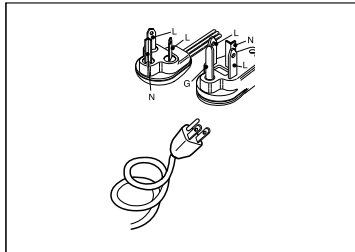

Enter diagnostic mode and press the START/PAUSE button twice. Measure the voltage between YL3-1 (WH) and the YL wire on the black tab relay. Is the voltage 240 VAC?

NO

- Check power supply.

YES

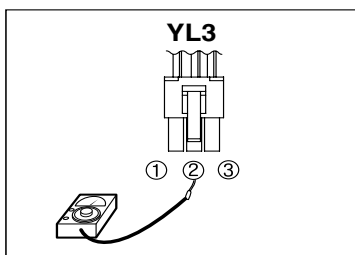

Disconnect the YL3, black tab relay and white tab relay connectors at the main PCB. Measure the resistance between YL3-1 (WH) and the YL wire on the black tab relay connector. Is the resistance 18-22  $\Omega$  ?

NO

- Check wiring and connectors to the element.
- See element component test.

YES

Measure the resistance between YL3-1 (WH) and the BL wire on the white tab relay connector. Is the resistance 18-22  $\Omega$  ?

NO

- Check wiring and connectors to the element.
- See element component test.

YES

Measure the resistance between the YL wire on the black tab relay and the BL wire on the white tab relay connectors. Is the resistance 36-44  $\Omega$  ?

NO

- Check wiring and connectors to the element.
- See element component test.

YES

Measure the resistance between terminals 1 (RD) and the heater housing. Is the resistance  $\Omega$  ?

NO

- Replace the element.

YES

Refer to the hi-limit thermostat and thermal cut off component tests.

## ■ Test 7 GAS Valve test - Gas Type

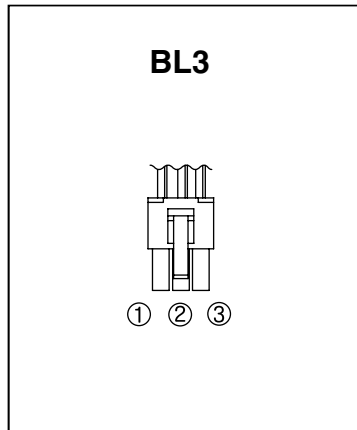

Disconnect the BL3 Connector from the main PCB and measure the resistance between BL3-1 (RD) and BL3-2 (PK). Is the resistance 1.5k-2.5k  $\Omega$  ?

**NO**

- Check wiring and connectors to gas valve.
- See gas valve component test.

**YES**

Measure the resistance between BL3-1 (RD) and BL3-3 (WH). Is the resistance 1.5k-2.5k  $\Omega$  ?

**NO**

- Check wiring and connectors to gas valve.
- See gas valve component test.

**YES**

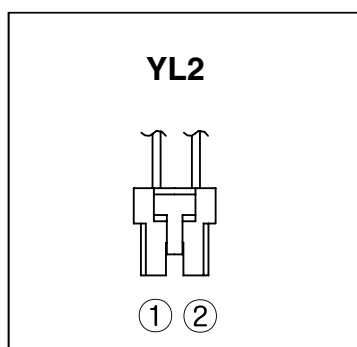

Disconnect the YL3 connector from the main PCB. Measure the resistance between YL3-1 (GY) and YL3-3 (BL). Is the resistance <1  $\Omega$  ?

**NO**

- Check wiring and connectors to flame sensor.
- See flame sensor component test.

**YES**

Measure the resistance between YL3-3 (BL) and the blue wire on the black tab relay. Is the resistance 100-800  $\Omega$  ?

**NO**

- Check wiring and connectors to the ignitor
- See ignitor component test

**YES**

The flame sensor is closed and the ignitor is OK.

- Perform the functional test above.
- Check all wiring and connectors to gas valve components.
- Check gas supply.

# 11

## CHANGE GAS SETTING (NATURAL GAS, PROPANE GAS)

**Warning** After Natural Gas Setting, applying Propane Gas Orifice or wrong use of Natural Gas Orifice will result in fire. Conversion must be made by a qualified technician.

**Initially**, Natural Gas mode is set. Propane Gas Orifice is on sale as a Service Part to authorized servicers only.

### STEP 1 : VALVE SETTING

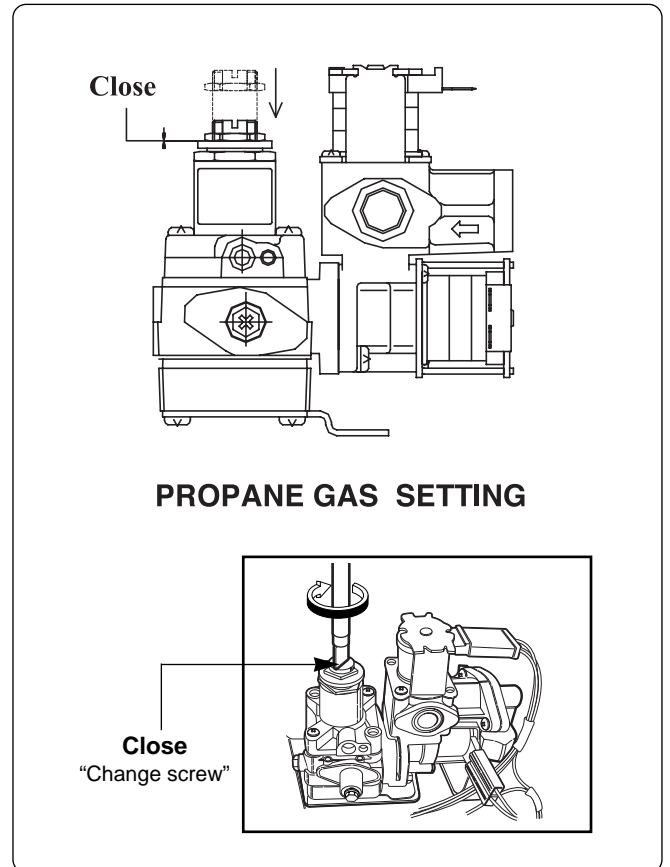
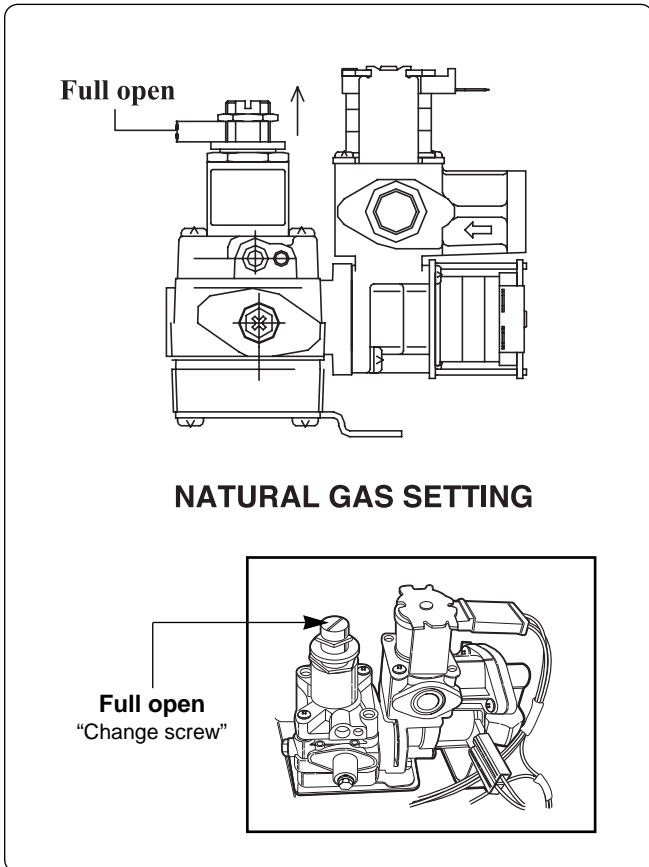

### STEP 2 : ORIFICE CHANGE

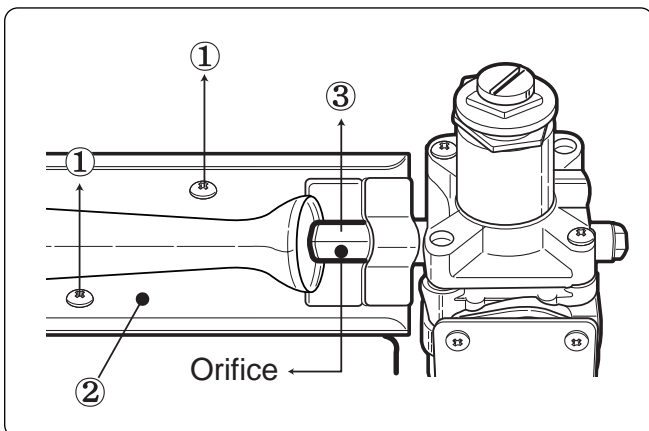

- ① Remove 2 screws.
- ② Disassemble the pipe assembly.
- ③ Replace Natural Gas orifice with Propane Gas orifice.

Gas type	Orifice P/No	Marking	Shape
Natural Gas	4948EL4001B	NCU	
Propane Gas	4948EL4002B	PCU	

※ **Kit contents** : Orifice (Dia. = 1.613mm, for Propane Gas)  
: Replace Label  
: Instruction sheet

## ■ GAS VALVE FLOW

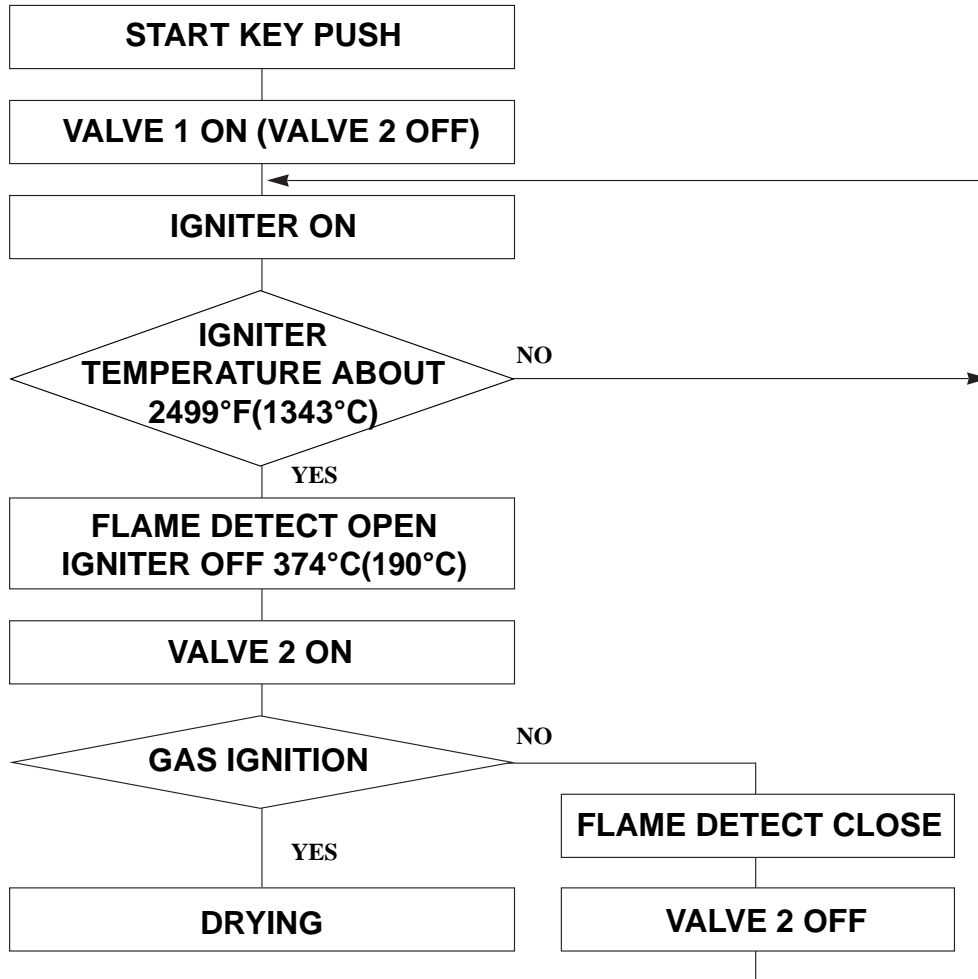

### GAS IGNITION

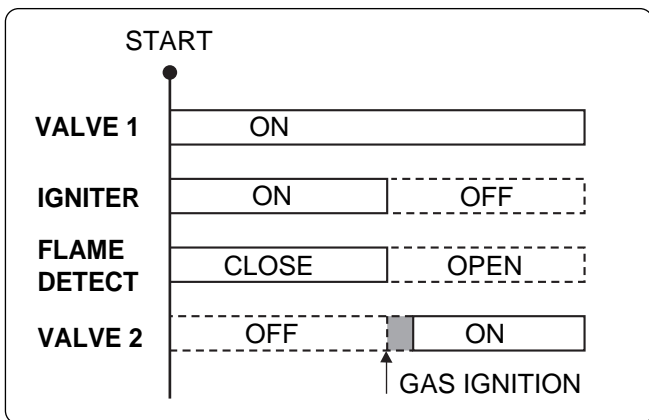

### GAS VALVE STRUCTURE

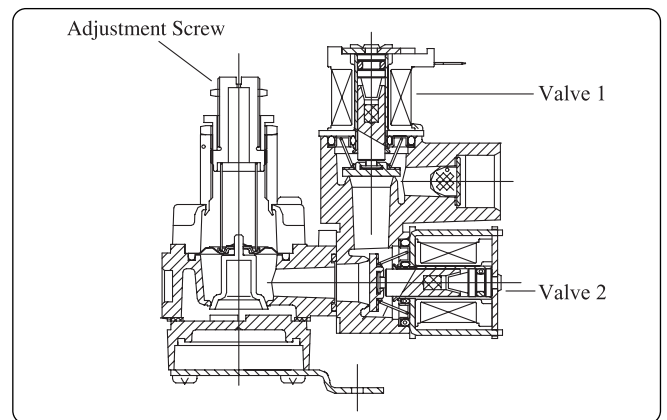

# 12

## DISASSEMBLY INSTRUCTION

\* Disassemble and repair the unit only after pulling out power plug from the outlet.

### TOP PLATE

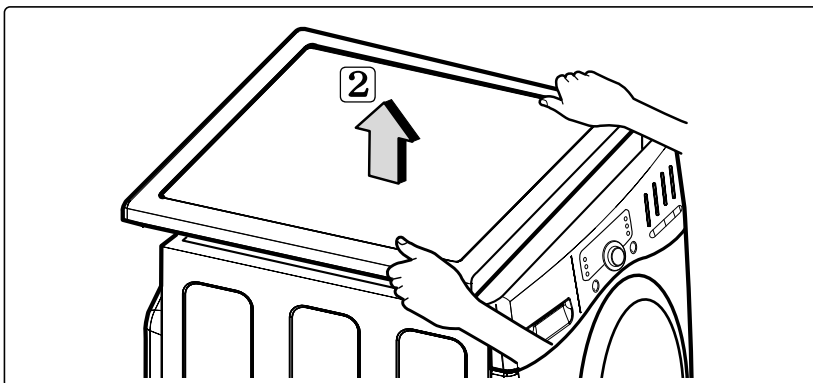
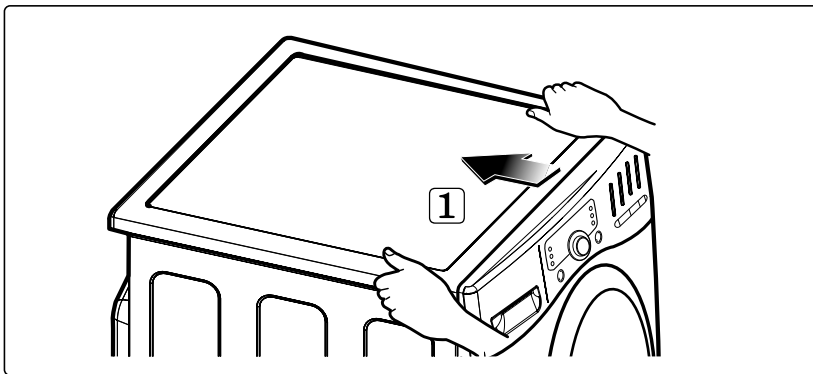
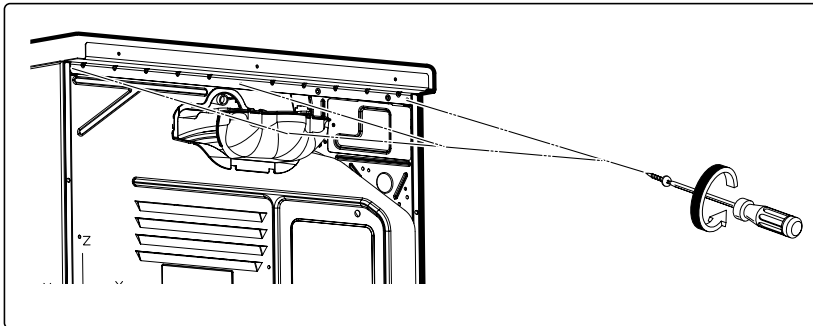
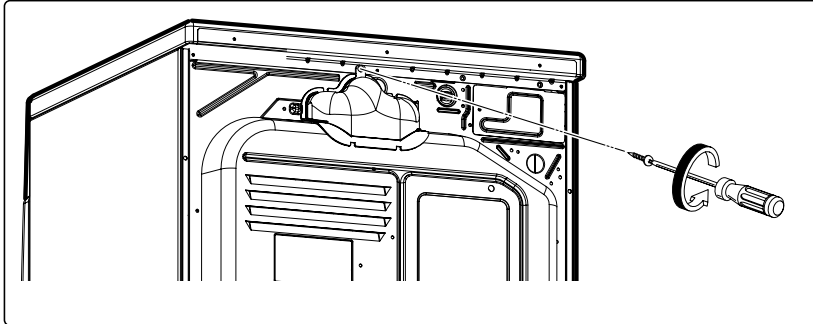

### **⚠ WARNING !**

When you disassemble the top plate, be sure to take gloves and careful plate edge. Failure to do so can cause serious injury.

1. Remove 1 screw on the safety guard.

2. Remove 3 screws on the upper plate.

3. Push the top plate backward.

4. Lift the top plate

## PANEL DRAWER ASSEMBLY

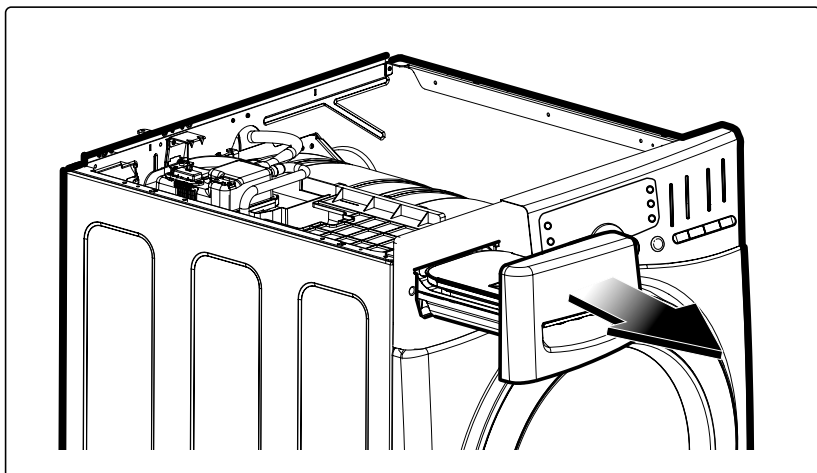

**1.** Pull out the drawer

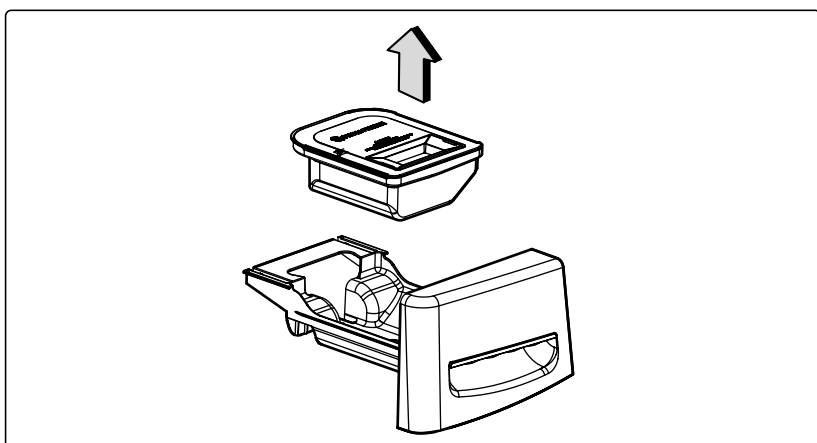

**2.** Lift out the water tank.

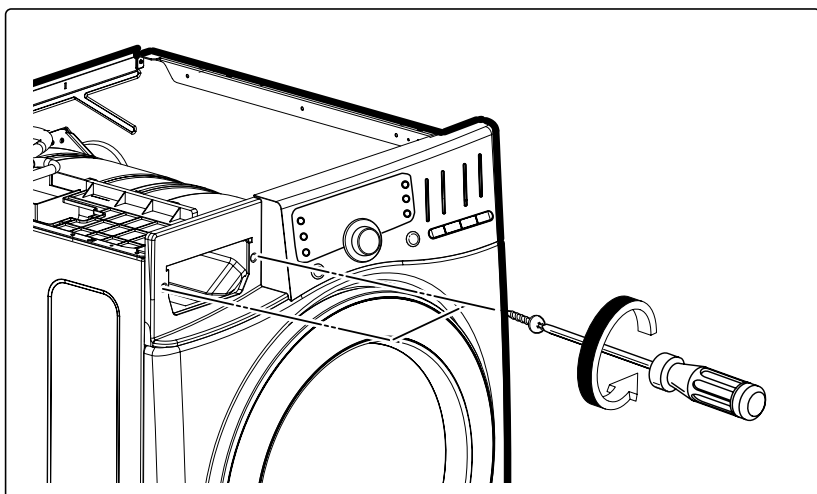

**3.** Remove 2 screws on the control panel.

## CONTROL PANEL ASSEMBLY

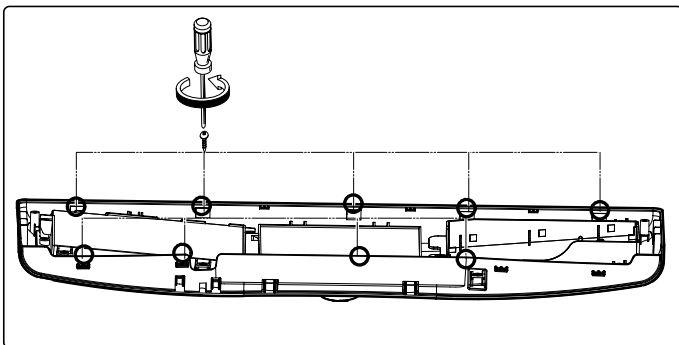
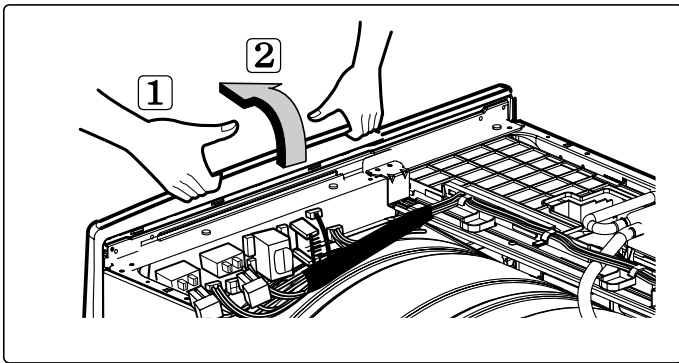
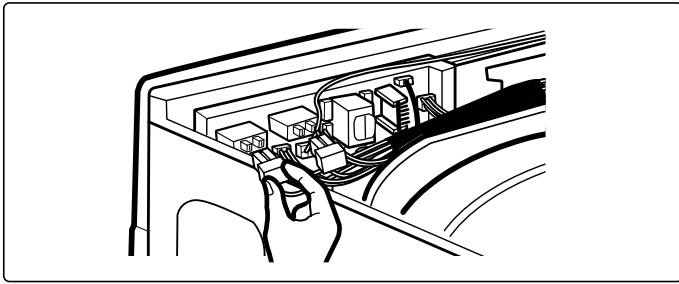
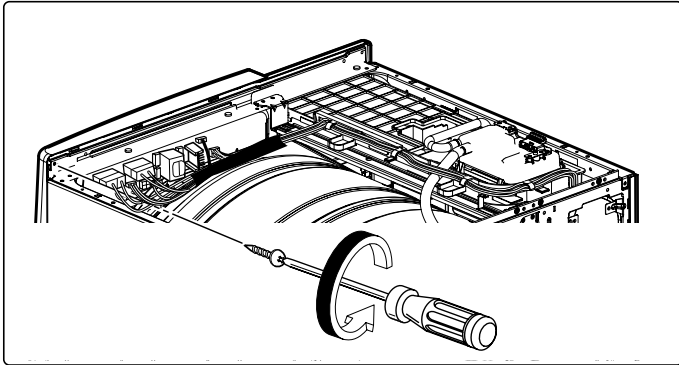

## **⚠ WARNING !**

When you disassemble the control panel, be sure to take gloves and careful panel frame edge. Failure to do so can cause serious injury.

1. Remove 1 screw on the control panel frame.
2. Disconnect the connectors.
3. Pull the control panel assembly upward and then forward.
4. Remove 8 screws on the PWB(PCB) assembly, display.
5. Disassemble the control panel assembly.

---

## COVER CABINET

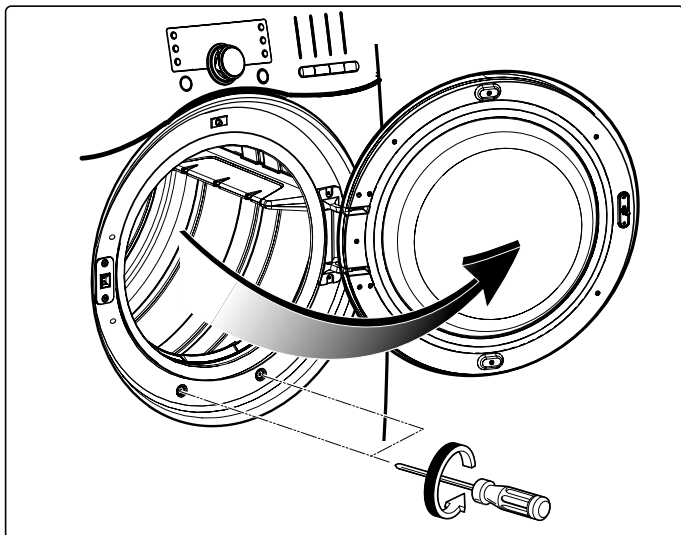

1. Disassemble the top plate.
2. Disassemble the control panel assembly.
3. Disassemble the door assembly.
4. Remove 2 screws.

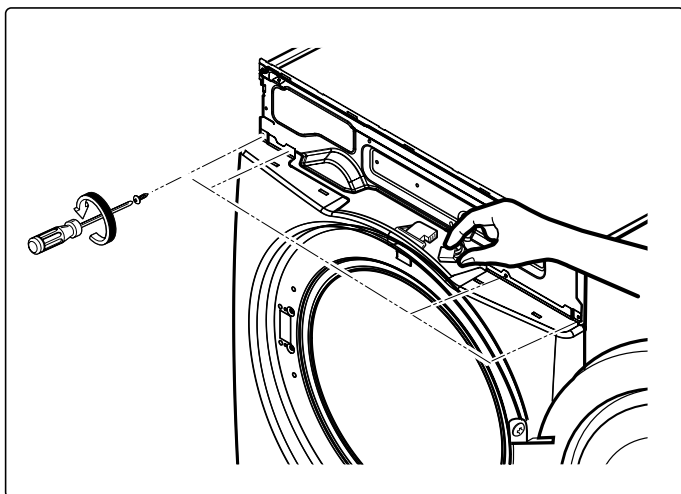

5. Remove 4 screws from the top of cabinet cover.
6. Disconnect the harness of door switch.

## GUIDE ASM

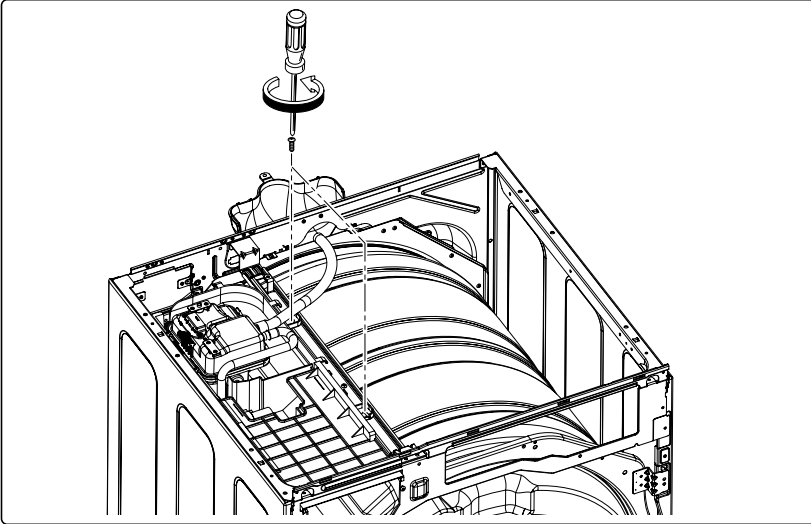

**1.** Remove 2 screws on the frame body.

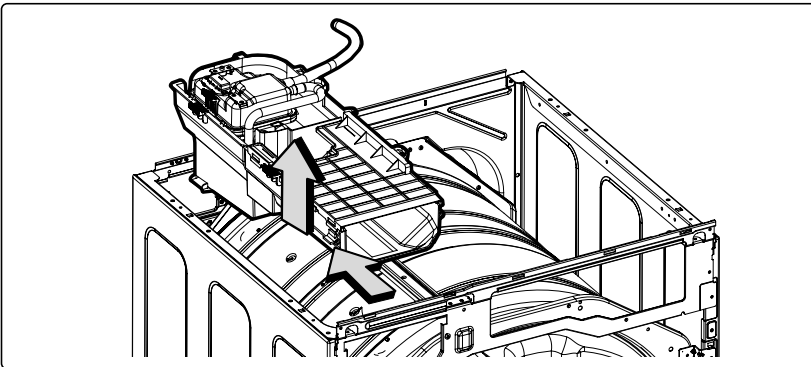

**2.** Push the Guide ASM to the back side and then lift it.

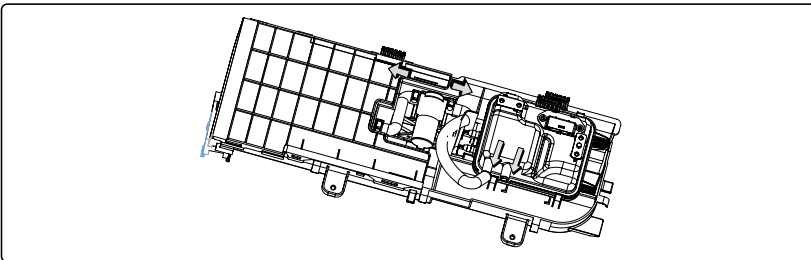

**3.** Separate hoses from the pump and generator.

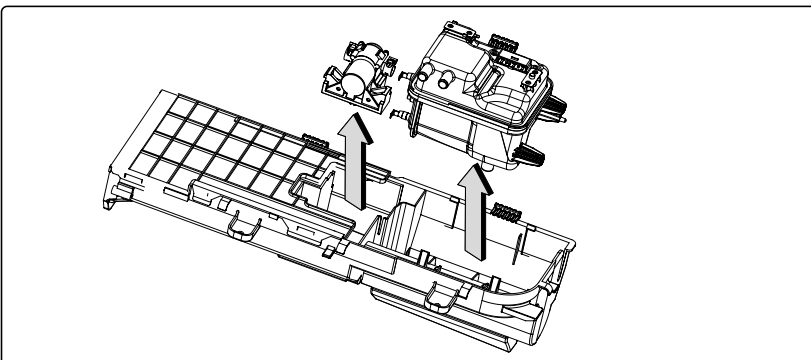

**4.** Lift a pump and a generator up.

## FRAME BODY & PANEL FRAME

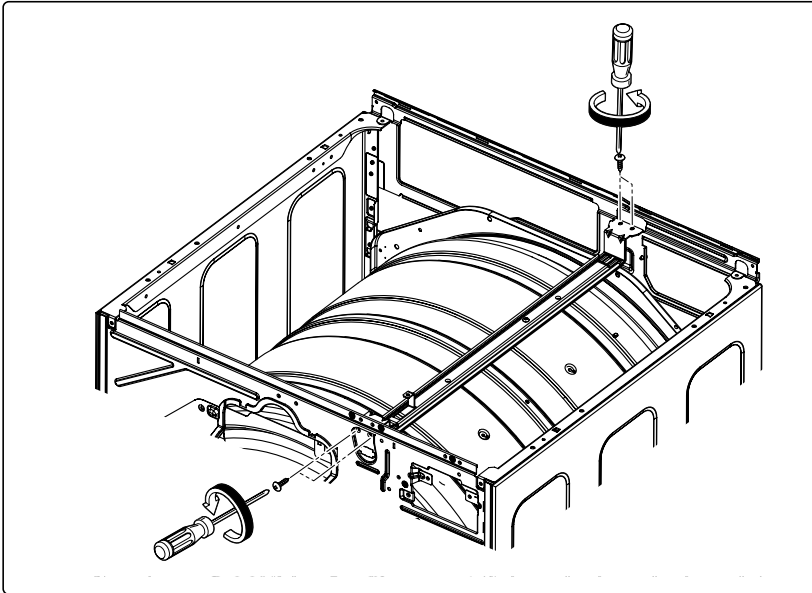

1. Remove 4 screws on the frame body and then disassemble the frame body.

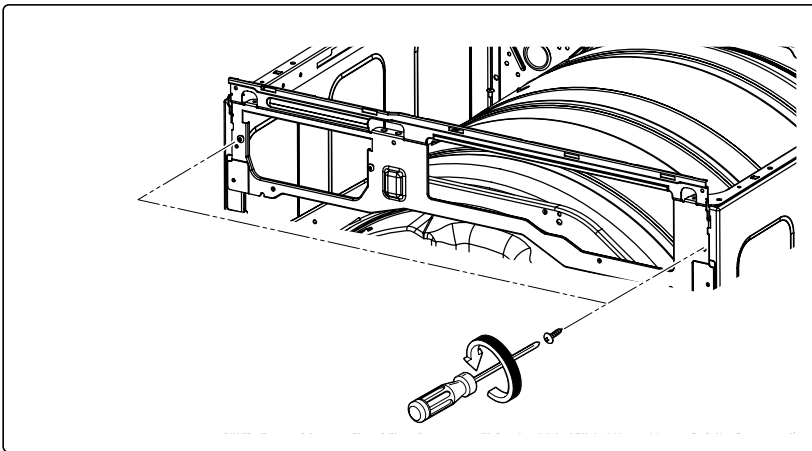

2. Remove 4 screws on the panel frame and then disassemble the panel frame.

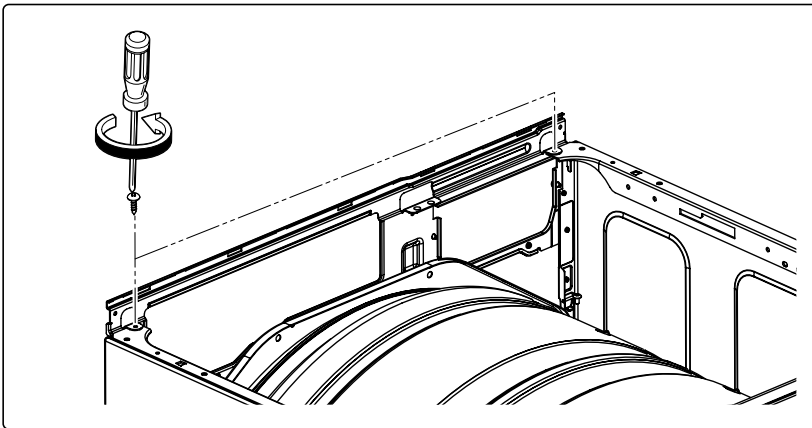

## TUB DRUM [FRONT]

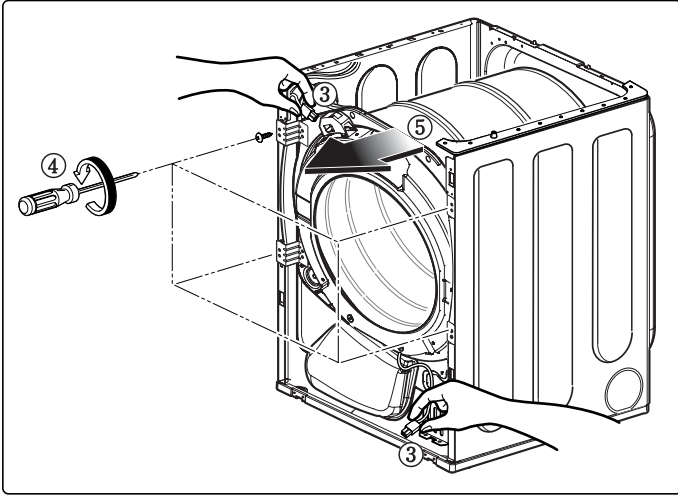

## **⚠ WARNING !**

When you disassemble the lamp connector, be sure to take gloves and careful cabinet edge. Failure to do so can cause serious injury.

1. Open the top plate.
2. Remove Cover Cabinet.
3. Disconnect the door lamp and electro sensor connector.
4. Remove 4 screws.
5. Disassemble the Tub Drum [Front].

## DRUM ASSEMBLY

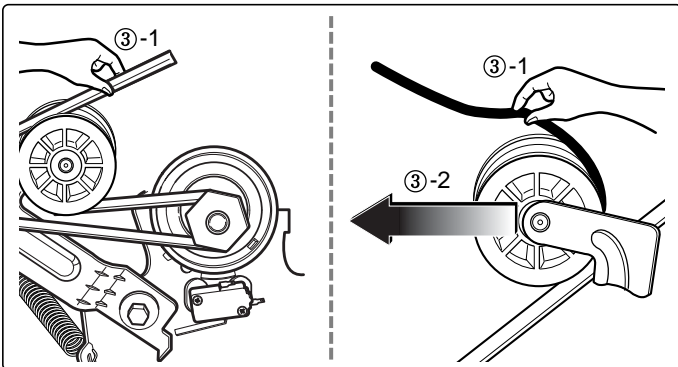

1. Open the top plate.
2. Remove the Cover Cabinet and Tub drum [front].
3. Disengage belt from motor and idler pulleys.
4. Carefully remove Drum out through front of dryer.

## CHANGING THE DRUM LAMP

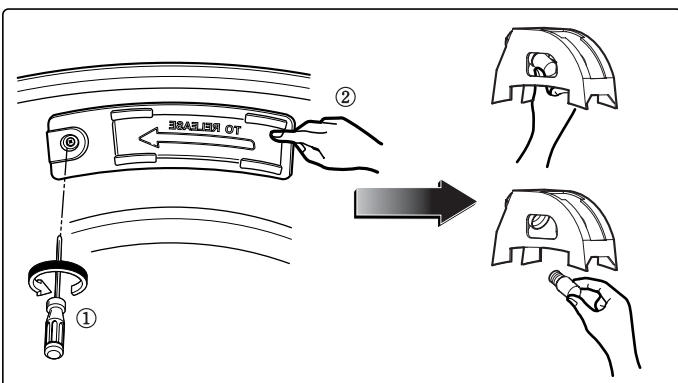

1. Open the door.
2. Remove the screw holding the drum lamp shield in place.
3. Slide the shield up and remove.
4. Remove the bulb and replace with a 15 watt, 120 volt candelabra-base bulb.
5. Replace the lamp shield and screw.

## DRYER EXHAUST CHANGE

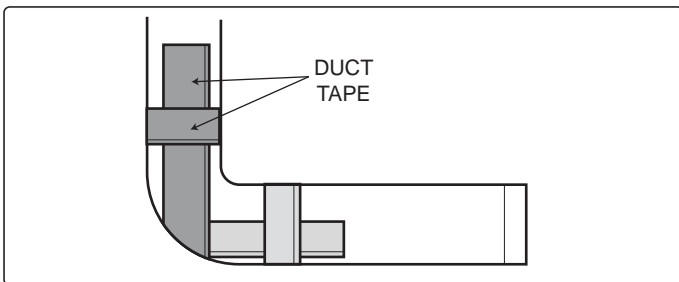
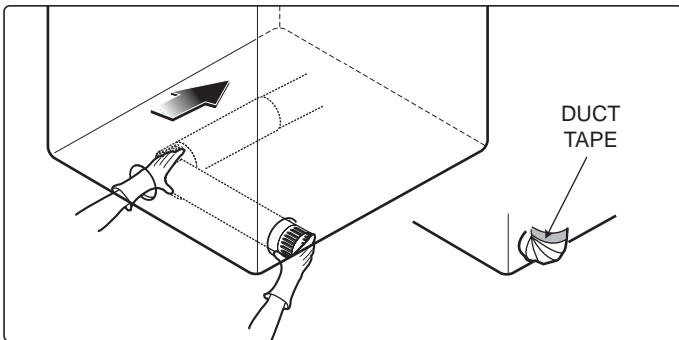
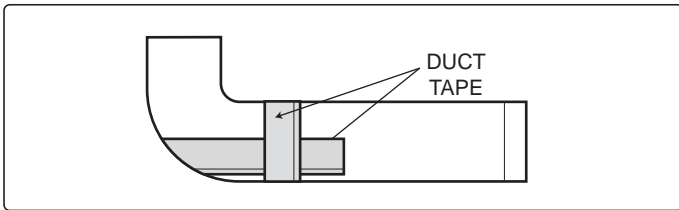
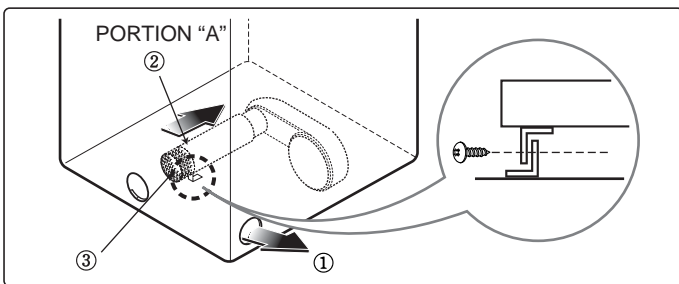
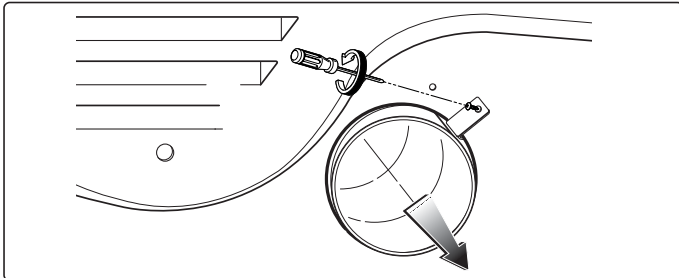

## **⚠ WARNING !**

When you disassemble and install ventilation, be sure to take gloves and careful exhaust edge. Failure to do so can cause serious injury.

1. Remove screw & exhaust duct.
2. Detach and remove the bottom, left or right side knockout as desired.
3. Reconnect the new duct[11 in(28cm)] to the blower housing, and attach the duct to the base.
4. Pre-assemble 4" elbow with 4" duct. Wrap duct tape around joint.
5. Insert duct assembly, elbow first, through the side opening and connect the elbow to the dryer internal duct.

## FILTER ASSEMBLY

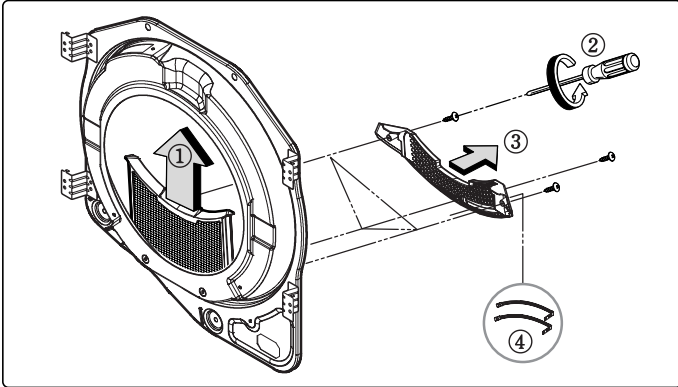

1. Remove the filter.
2. Remove 3 screws.
3. Pull the grill.
4. Disconnect electro sensor.

## BLOWER HOUSING

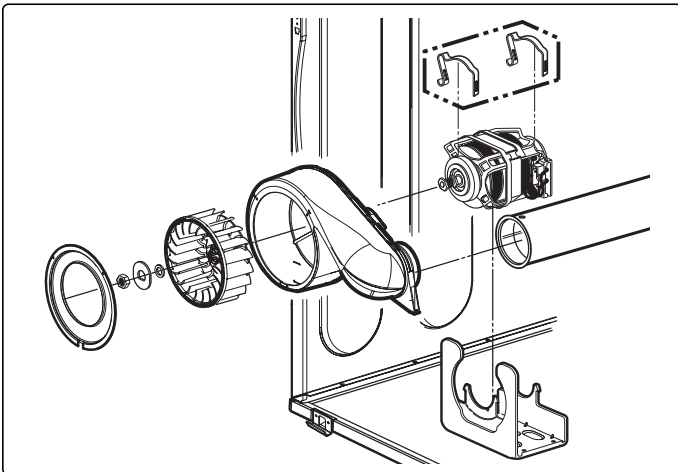

1. Open the top plate.
2. Remove the Cover Cabinet and Tub Drum [Front].
3. Remove the Drum assembly.
4. Remove 2 screws and cover(Air guide).
5. Remove the bolt and washer.
6. Pull the fan.
7. Disconnect the motor clamp and motor.

## BACK COVER

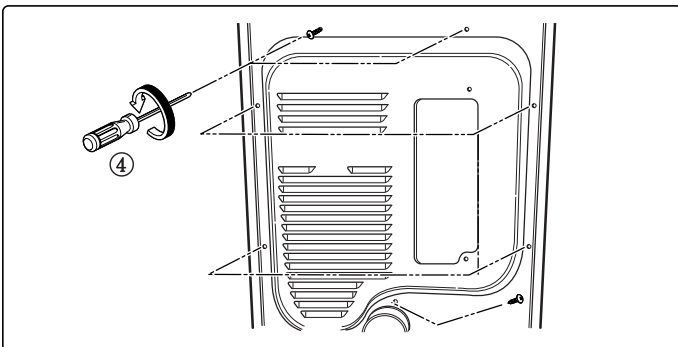

1. Open the top plate.
2. Remove the Cover Cabinet and Tub Drum [Front].
3. Remove the Drum assembly.
4. Remove 7 screws.
5. Pull the Tub Drum [Rear] towards the front.

## AIR DUCT

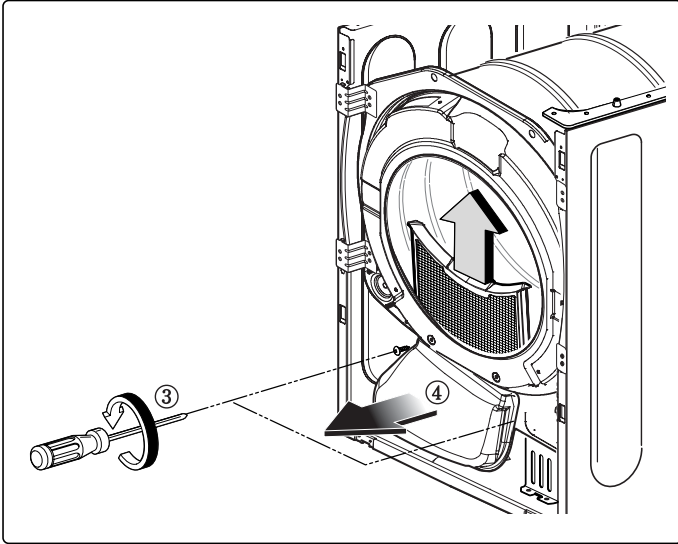

1. Open the top plate.
2. Remove the Cover Cabinet.
3. Remove filter and 2 screws.
4. Pull the air duct towards the front.

## ROLLERS

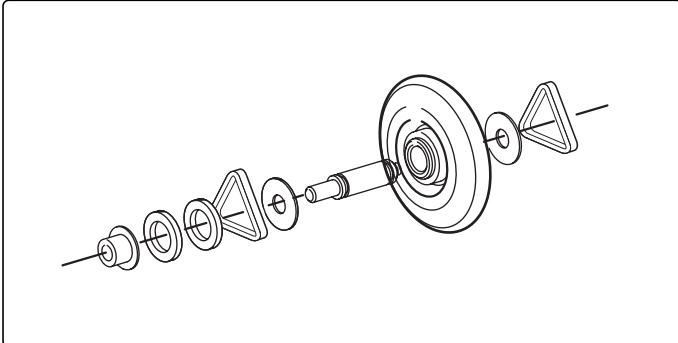

1. Open the top plate.
2. Remove the Cover Cabinet and Tub Drum [Front].
3. Remove the Drum assembly and Tub Drum [Rear].
4. Disconnect Air duct from the Tub Drum [Front].
5. Remove the roller from the Tub Drum [Front] and Tub Drum [Rear].

# 13

## EXPLODED VIEW

### 13-1. Control Panel & Plate Assembly

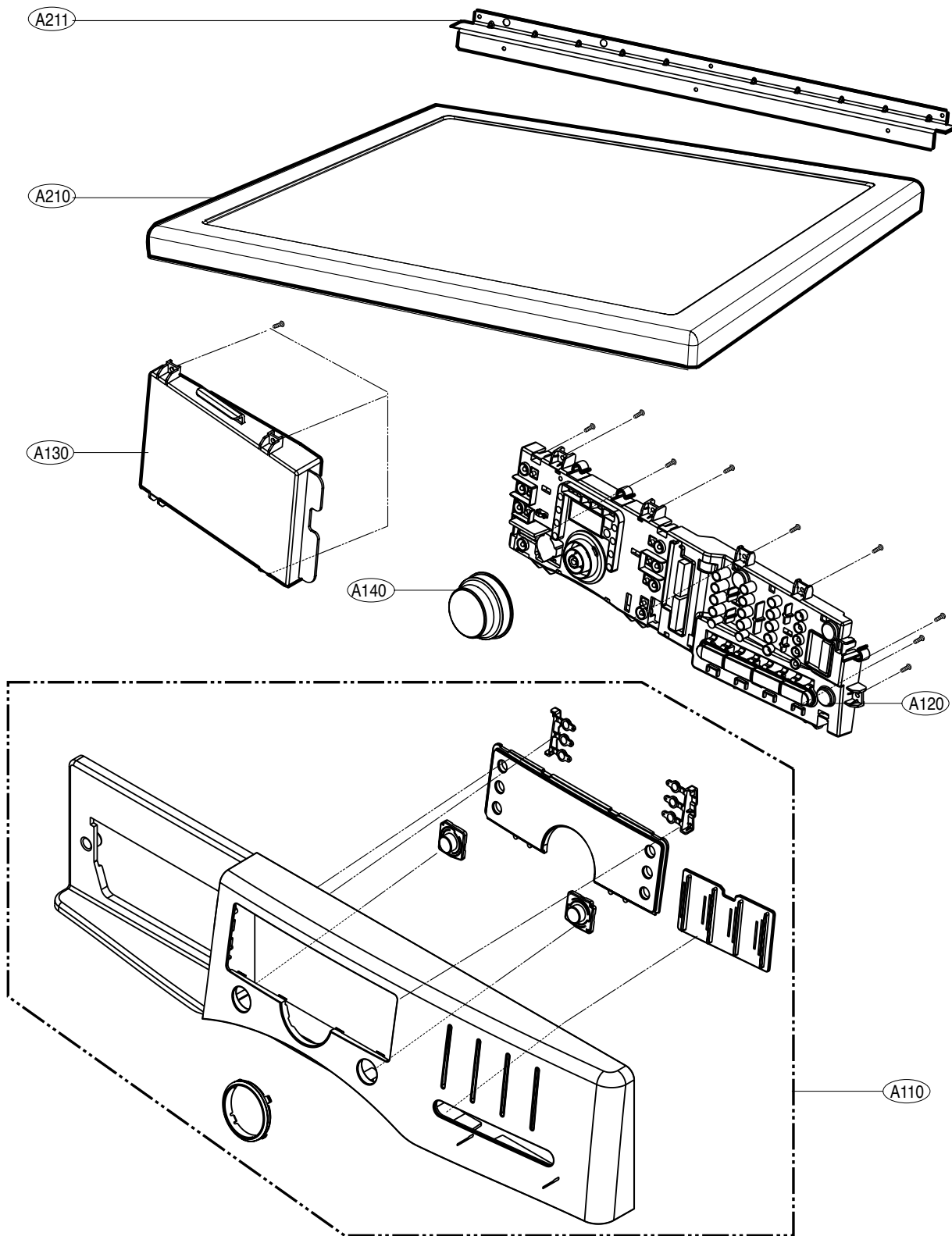

## 13-2. Panel Drawer Assembly & Guide Assembly

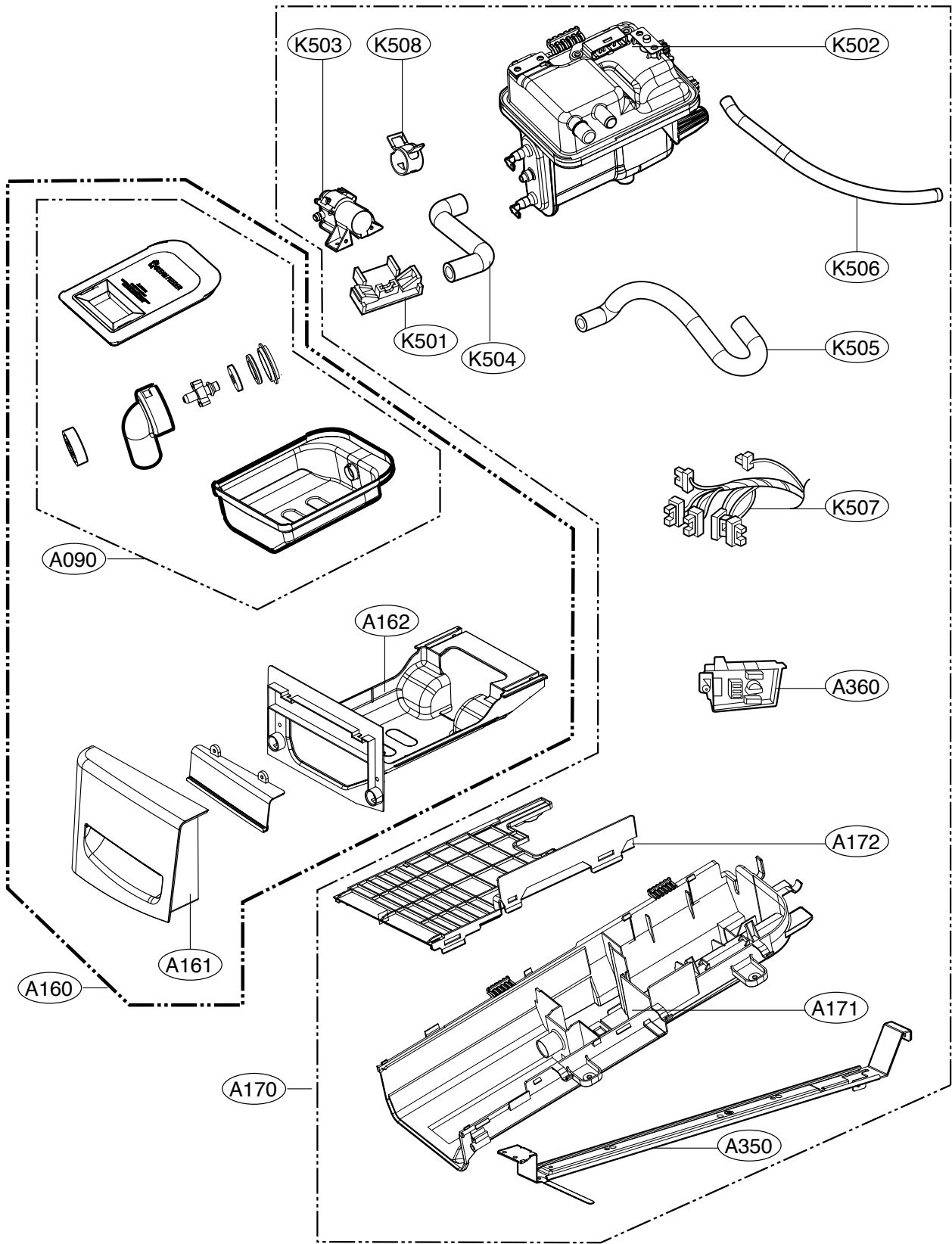

# 13-3. Cabinet & Door Assembly

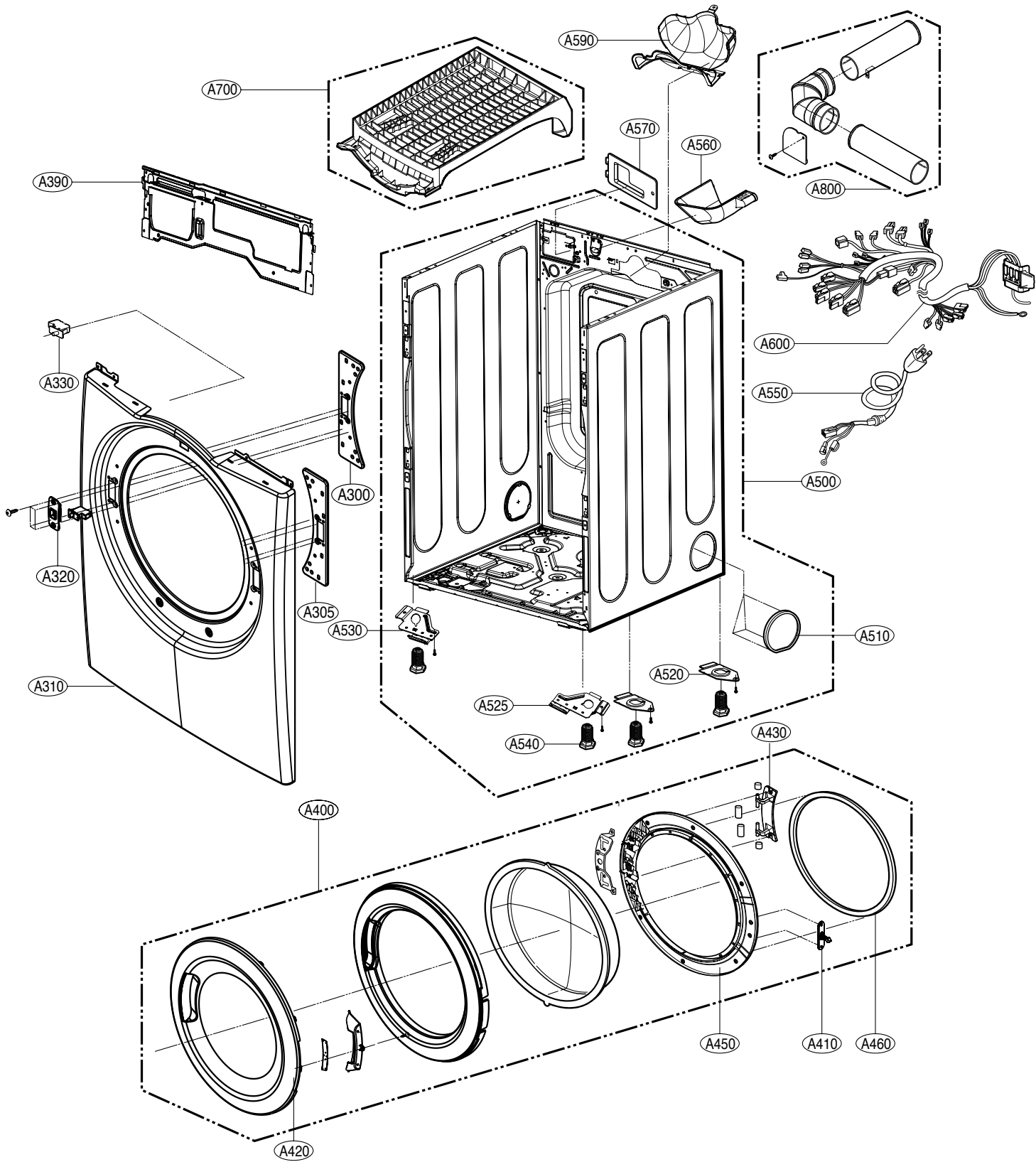

# 13-4-1. Drum & Motor Assembly: Electric Type

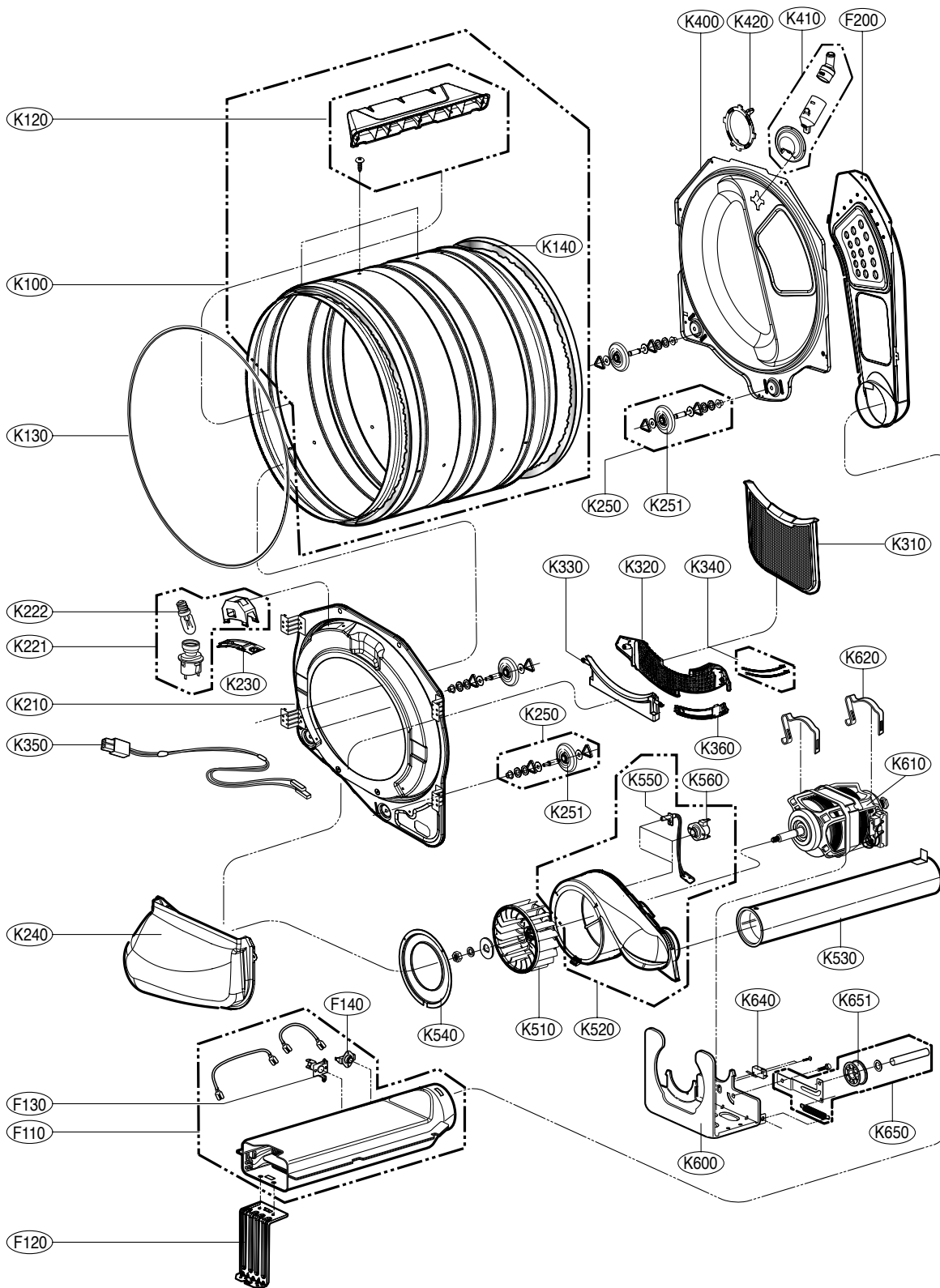

# 13-4-2. Drum & Motor Assembly: Gas type

