



Website: <http://sears.com>

ELECTRIC & GAS DRYER SERVICE MANUAL

CAUTION

READ THIS MANUAL CAREFULLY IN ORDER TO
PROPERLY DIAGNOSE PROBLEMS AND TO SAFELY
PROVIDE QUALITY SERVICE ON THESE DRYERS.

MODEL : 795.851 .900**
795.921 .900**



JUNE. 2009 PRINTED IN KOREA

P/No.: MFL62119904

IMPORTANT SAFETY NOTICE

The information in this service guide is intended for use by individuals possessing skill and experience in electrical, electronic, and mechanical appliance repair. Any attempt to repair a major appliance may result in personal injury and property damage. The manufacturer or seller cannot be responsible for the interpretation of this information, nor can it assume any liability in connection with its use.

WARNING !

To avoid personal injury, disconnect power before servicing this product. If electrical power is required for diagnosis or test purposes, disconnect the power immediately after performing the necessary checks.

RECONNECT ALL GROUNDING DEVICES

If grounding wires, screws, straps, clips, nuts, or washers used to complete a path to ground are removed for service, they must be returned to their original position and properly fastened.

WHAT TO DO IF YOU SMELL GAS:

- *Do not try to light a match, or cigarette, or turn on any gas or electrical appliance.*
- *Do not touch any electrical switches. Do not use any phone in your building.*
- *Clear the room, building or area of all occupants.*
- *Immediately call your gas supplier from a neighbor's phone. Follow the gas supplier's instructions carefully.*
- *If you cannot reach your gas supplier, call the fire department.*

IMPORTANT

Electrostatic Discharge (ESD)
Sensitive Electronics

ESD problems are present everywhere. ESD may damage or weaken the electronic control assembly. The new control assembly may appear to work well after repair is finished, but failure may occur at a later date due to ESD stress.

- Use an anti-static wrist strap. Connect wrist strap to green ground connection point or unpainted metal in the appliance.

- OR -

Touch your finger repeatedly to a green ground connection point or unpainted metal in the appliance.

- Before removing the part from its package, touch the anti-static bag to a green ground connection point or unpainted metal in the appliance.
- Avoid touching electronic parts or terminal contacts; handle electronic control assembly by edges only.
- When repackaging failed electronic control assembly in anti-static bag, observe above instructions.

CONTENTS

1. SPECIFICATIONS	4
2. FEATURES AND BENEFITS	6
3. INSTALLATION INSTRUCTIONS	6
4. DRYER CYCLE PROCESS	13
5. COMPONENT TESTING INFORMATION	14
6. MOTOR DIAGRAM AND SCHEMATIC	17
7. WIRING DIAGRAM	18
8. STEAM FUNCTION	19
8-1. STEAM CYCLE GUIDE	19
8-2. TROUBLESHOOTING FOR STEAM DRYER	20
8-3. DISPLAY FAULT/ERROR CODES FOR STEAM DRYER	21
9. FLOW SENSOR FUNCTION	22
9-1. FLOW SENSOR	22
9-2. INSTALLATION CHECK	23
9-3. TROUBLESHOOTING FOR FLOW SENSOR DRYER	24
10. DIAGNOSTIC TEST	25
10-1. TEST 1 120V AC ELECTRICAL SUPPLY	26
10-2. TEST 2 THERMISTOR TEST - MEASURE WITH POWER OFF	29
10-3. TEST 3 MOTOR TEST	30
10-4. TEST 4 MOISTURE SENSOR	31
10-5. TEST 5 DOOR SWITCH TEST	32
10-6. TEST 6 HEATER SWITCH TEST - ELECTRIC TYPE	33
10-7. TEST 7 GAS VALVE TEST - GAS TYPE	34
10-8. TEST 8 SEMI-CONDUCTOR	35
10-9. TEST 9 MOTOR ASSEMBLY, DC, PUMP	35
10-10. TEST 10 GENERATOR ASSEMBLY	36
11. CHANGE GAS SETTING (NATURAL GAS, PROPANE GAS)	37
12. DISASSEMBLY INSTRUCTIONS	39
13. EXPLODED VIEW	49
13-1. CONTROL PANEL & PLATE ASSEMBLY	49
13-2. PANEL DRAWER ASSEMBLY & GUIDE ASSEMBLY	50
13-3-1. CABINET & DOOR ASSEMBLY: ELECTRIC TYPE	51
13-3-2. CABINET & DOOR ASSEMBLY: GAS TYPE	52
13-4-1. DRUM & MOTOR ASSEMBLY: ELECTRIC TYPE	53
13-4-2. DRUM & MOTOR ASSEMBLY: GAS TYPE	54

1

SPECIFICATIONS

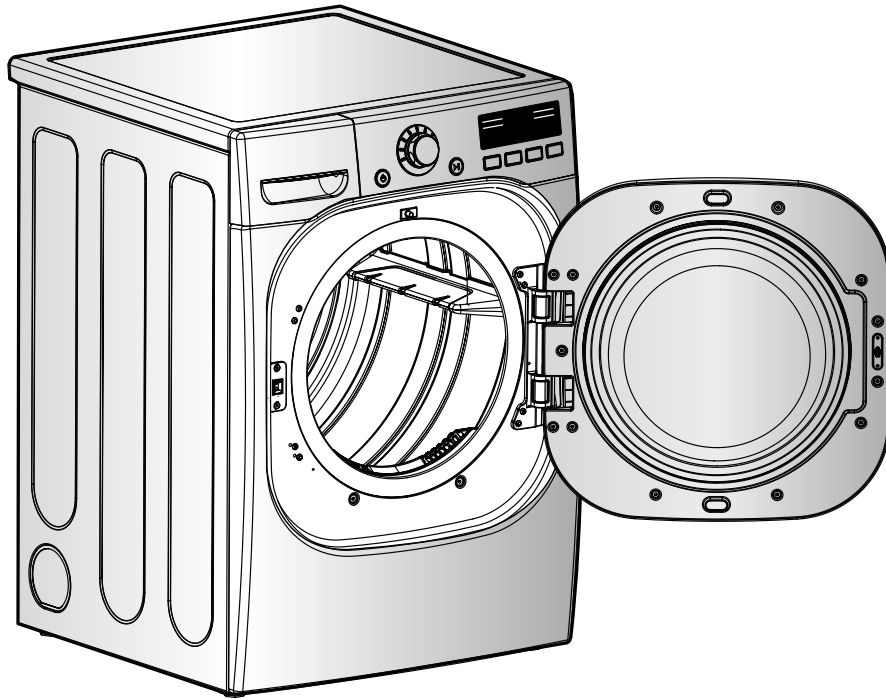

- Name: Electric and Gas Dryer
- Power supply: Please refer to the rating label regarding detailed information.
- Size : 27 X 30 X 38.7 (inch)
- Dryer capacity: IEC 7.4 cu.ft.
- Weight: 136(lbs)

Specifications are subject to change by manufacturer.

ACCESSORIES

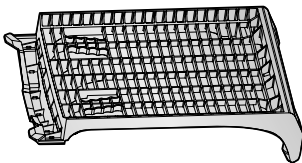

Dryer rack (1 each)

See page 6



Stacking kit (1 each)
Purchased Separately

See page 7

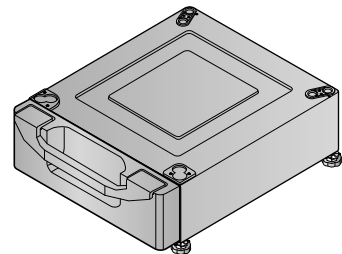

Pedestal (1 each)
Purchased Separately

See page 8

ITEM		795.851**.900 795.921**.900	REMARK
Material & Finish	Color	Blue White / Candy Red / Patina beige	
	Top Plate	Porcelain	
	Door Trim	Chromate	
POWER SUPPLY		120V/240V 60Hz (26A)	
ELECTRICITY CONSUMPTION	MOTOR	250W (4.5A)	AC 120V
	HEATER	5400W (22.5A)	AC 240V(ELECTRIC MODEL)
	LAMP	15 W (0.2A)	AC 120V
	GAS VALVE	13 W (0.11A) x 2	AC 120V(GAS MODEL)
	AG HEATER	1100W (9.2A)	AC 120V(STEAM MODEL)
	DC, PUMP	2.4W (0.15A)	DC 9V(STEAM MODEL)
CONTROL TYPE		Electronic	
DRUM CAPACITY		7.4 cu.ft.	
Weight (lbs) - Net/Gross		136 / 155.7	
No. of Programs		14	
No. of Dry Options		8	
No. of Temperature Controls		5	
No. of Dry Levels		5	
Sound levels		5	
Sensor	Moisture	Available	Electrode sensor
	Temperature	Available	Thermistor
Reversible Door		Available	
Drum		Stainless Steel	
Dryer Rack		Available	
Control Lock		Available	
Interior Light		Available	
Product (WxHxD)		27" x 42 3/4" x 28 1/3"	
Packing (WxHxD)		29 1/2" x 44 3/4" x 30 3/4"	

2

FEATURES AND BENEFITS



3

INSTALLATION INSTRUCTIONS

Dryer Rack Installation Instructions

1 Open the door. Hold the dryer rack with both hands.

2 Put the dryer rack into the drum

3 Check and be sure that the front of the rack is properly seated behind the lint filter.

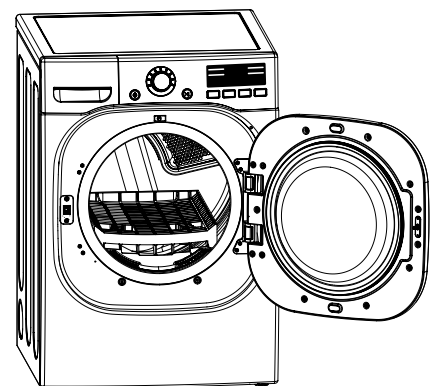
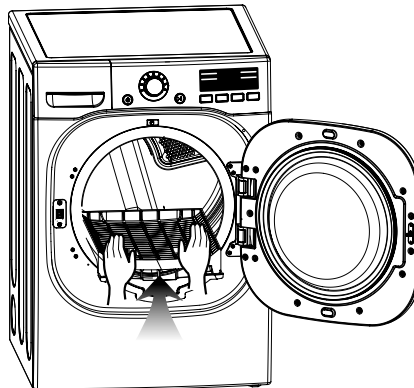
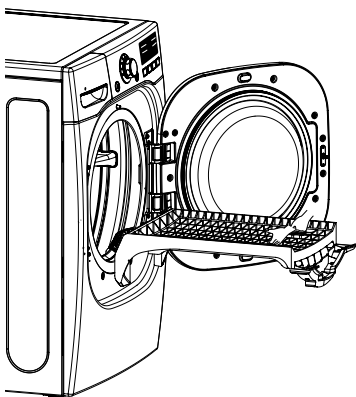

Stacking Kit Installation Instructions

To ensure safe and secure installation, please observe the instructions below.

WARNING

Do not attempt this alone!

At least two people are required to lift and position the dryer on top of a washing machine!

Failure to heed this warning can result in serious physical injury and damage to the appliance.



Stacking kit

- 1** Place the washer firmly on a stable, even and solid floor as product installation instructions describe in the owner's manual.
- 2** Peel the protective paper from the tape on the side bracket.

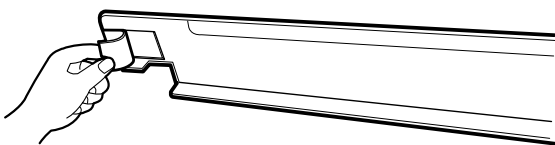

- 3** Fit the side bracket firmly to the side of the top plate by attaching the double-faced tape to the top plate as picture shown.

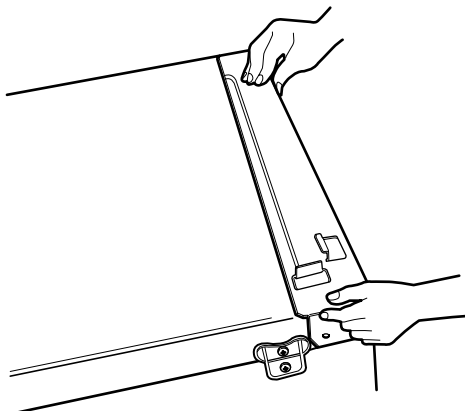

- 4** Secure the side bracket to the washer with a screw on the back of the bracket. Repeat Steps 2, 3, & 4 for the other side.

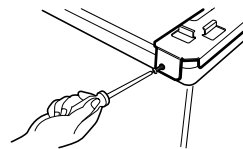

- 5** Place the dryer on top of the washer by placing the legs as shown. Be careful not to pinch fingers between the washer and dryer. Slide the dryer back against the stop on the side rail.

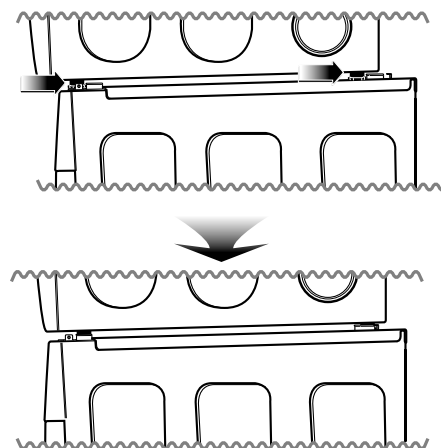

- 6** Insert the front rail of the stacking kit. Push the front rail back against the stops on the side brackets.

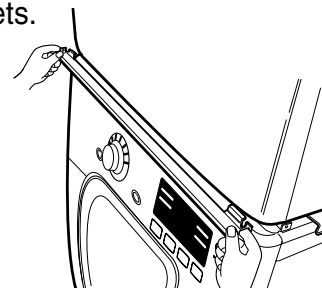

- 7** Screw both sides of the front rail to the side brackets.

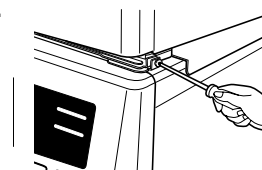

- Do not use a stacking kit with a gas dryer in potentially unstable conditions like a mobile home.

Pedestal Installation Instructions

The pedestal accessory includes:

- Drawer divider (1)
- Wrench (1)
- Screws (18) †
- Retainers (4) ††

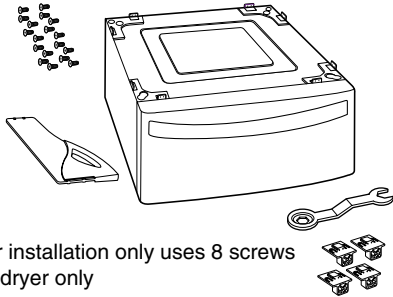

† Dryer installation only uses 8 screws
 †† For dryer only

Tools Needed for Installation:

- Phillips-head screwdriver
- Wrench (supplied)

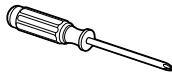

To ensure safe and secure installation, please thoroughly follow the instructions below.

⚠ WARNING

- **Incorrect installation can cause serious accidents.**
- **The appliances are heavy. Two or more people are required when installing the pedestal.** There is a risk of serious back injury or other injuries.
- **Do not allow children to play in or on the drawer.** There is a risk of suffocation or injury.
- **Do not step on the handle.** There is a risk of serious injury.
- **If appliances are already installed, disconnect them from all power, water, or gas lines and from draining or venting connections.** Failure to do so can result in electrical shock, fire, explosion, or death.
- **When installing, gloves must be put on.**

- 1 Make sure the leveling feet of the dryer are fully retracted.
NOTE: The appliance and pedestal assembly must be placed on a solid, sturdy, level floor for proper operation.

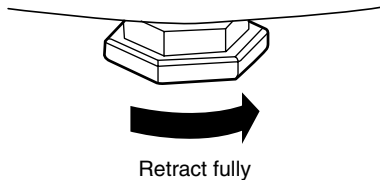

Retract fully

- 2 Insert the T-clip of the 4 retainers into the dryer base as shown. Press up on the back of the clip and pull outward to lock into place.

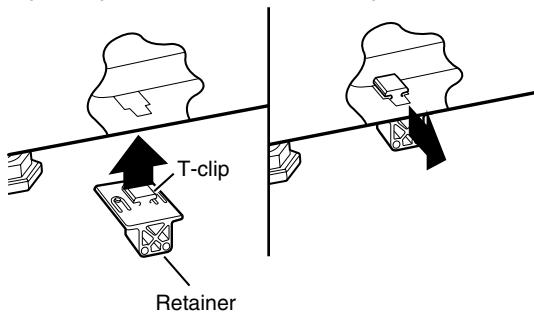

T-clip

Retainer

- 3 Place the dryer on the pedestal. Make sure the front and back feet are in the correct positions. The dryer feet will fit into the innermost positions as shown.

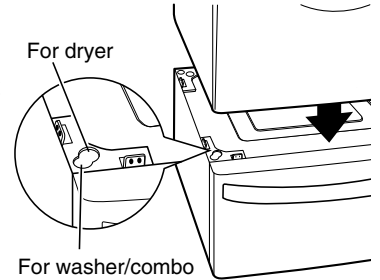

- 4 Make sure the screws on the pedestal align with the holes in the retainers, then install 4 screws on each side to securely attach the appliance to the pedestal.

NOTE: If the screws are not installed properly, noise and vibration may result.

Move the appliance to the desired location.

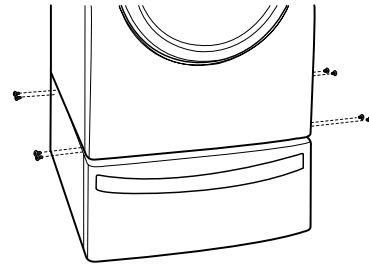

- 5 Loosen the locknuts on all 4 leveling feet of the pedestal until you can turn them with the wrench. Turn clockwise to raise or counterclockwise to lower until the pedestal is level and all 4 feet are solidly against the floor.

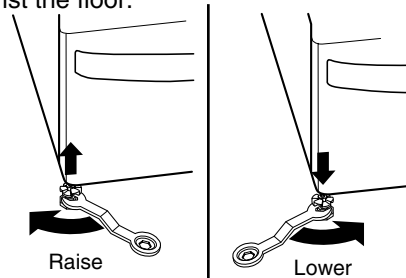

Raise

Lower

- 6 Securely tighten all locknuts by hand.
NOTE: Noise and vibration may result if locknuts are not tightened.

Be sure to connect the appliances to all water, power, or gas lines and draining or venting connections before operation.

If there is excessive vibration during the first operation after installation, slightly adjust the leveling feet.

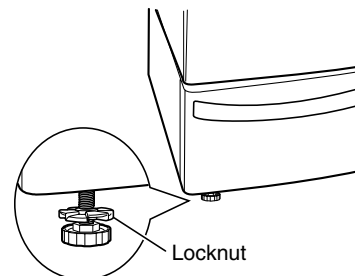

Locknut

Electric Dryer Only

Review the following options to determine the appropriate electrical connection for your home:

	<p>4-wire receptacle (NEMA type 14-30R)</p>
---	--

Use the instructions under option 1 if your home has a 4-wire receptacle (NEMA type 14-30R).

	<p>3-wire receptacle (NEMA type 10-30R)</p>
---	--

Use the instructions under option 2 or 3 if your home has a 3-wire receptacle (NEMA type 10-30R). Use option 2 if local codes and ordinances permit the connection of a chassis ground to the neutral connector. If this is not permitted, use option 3.

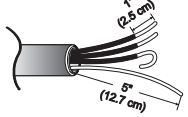
	<p>4-wire direct</p>
---	-----------------------------

If this type is available at your home, you will be connecting to a fused disconnect or circuit breaker box

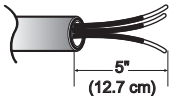
	<p>3-wire direct</p>
---	-----------------------------

If this type is available at your home, you will be connecting to a fused disconnect or circuit breaker box

4-wire connection : Direct wire

Important : Grounding through the neutral conductor is prohibited for (1) new branch-circuit installations, (2) mobile homes, and (3) recreational vehicles, and (4) areas where local codes prohibit grounding through the neutral conductor.

Prepare minimum 5ft(1.52m) of length in order for dryer to be replaced.

First, peel 5 inch (12.7cm) of covering material from end. Make a 5 inch of ground wire bared. After cutting 1½ inch (3.8cm) from 3 other wires, peel insulation back 1inch (2.5cm). Make ends of 3 wires a hook shape.

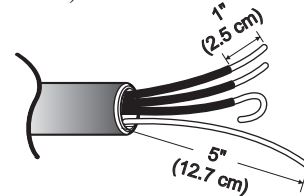

Then, put the hooked shape end of the wire under the screw of the terminal block(hooked end facing rightward) and pinch the hook together and screw tightly.

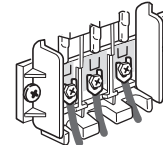

1. Connect neutral wire(white) of power cord to center terminal block screw.
2. Connect red and black wire to the left and right terminal block screws.
3. Connect ground wire(green) of power cord to external ground screw and move neutral ground wire of appliance and connect it to center screw.
4. Make sure that the strain relief screw is tightened. and be sure that all terminal block nuts are on tight and power cord is in right position.

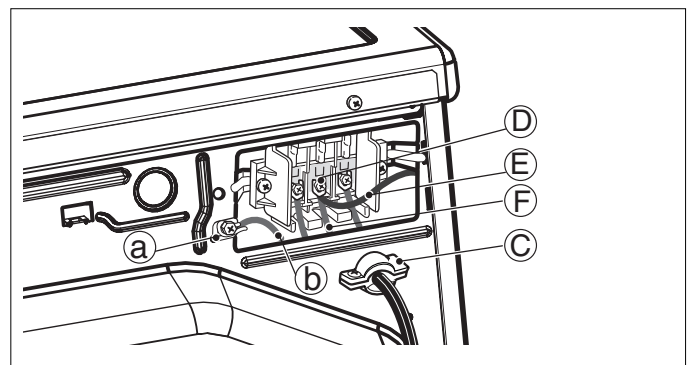

3-wire connection : Direct wire

Important : Grounding through the neutral conductor is prohibited for (1) new branch-circuit installations, (2) mobile homes, and (3) recreational vehicles, and (4) areas where local codes prohibit grounding through the neutral conductor.

Prepare minimum 5ft(1.52m) of length in order for dryer to be replaced.

First, peel 3 1/2 inch (8.9cm) of covering material from end and bare 1 inch from the ends.

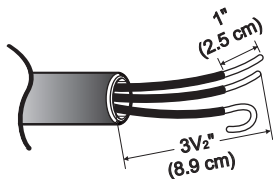

Then, put the hooked shape end of the wire under the screw of the terminal block (hooked end facing rightward) and pinch the hook together and screw tightly.

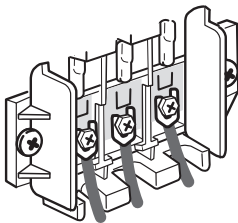

1. Connect neutral wire (white) of power cord to center terminal block screw.
2. Connect red and black wire to the left and right terminal block screws.
3. Make sure that the strain relief screw is tightened and be sure that all terminal block nuts are on tight and power cord is in right position.

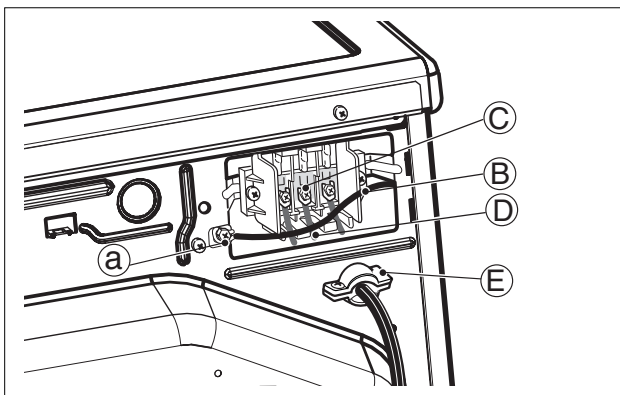

Option 1: 4-wire connection with a Power supply cord.

- If your local codes or ordinances do not allow the use of a 3 wire connection, or you are installing your dryer in a mobile home, you must use a 4-wire connection.

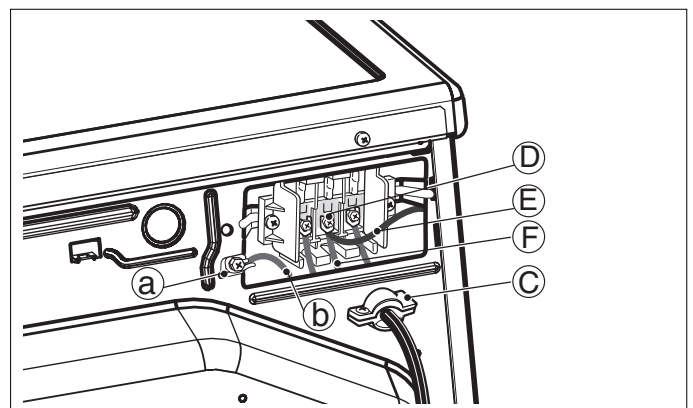
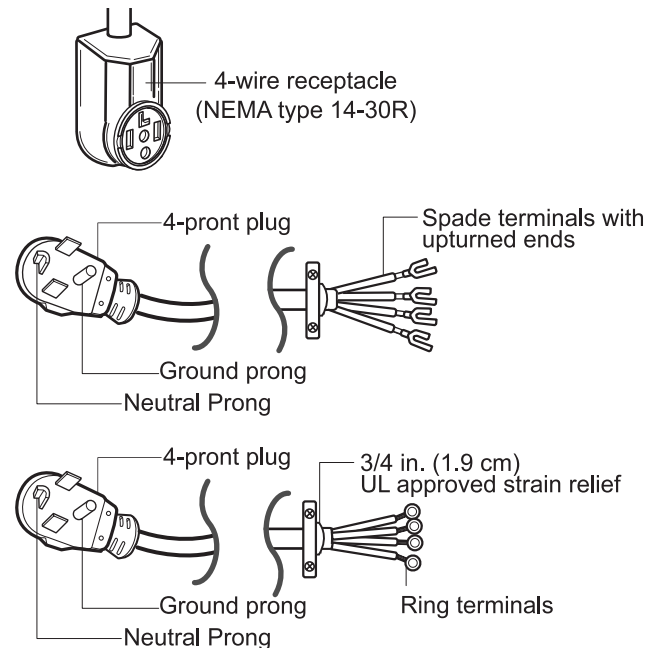

1. Connect the neutral wire (white) of the power cord to the center terminal block screw.
2. Connect the red and black wires to the left and right terminal block screws.
3. Connect the ground wire (green) of the power cord to the external ground screw. Remove the neutral ground wire of appliance and connect it to center screw.
4. Make sure that the strain relief screw is tightened and that all terminal block nuts are tight and the power cord is in the right position.

Option 2: 3-Wire Connection with a Power Supply Cord

If your local codes or ordinances permit the connection of a frame-grounding conductor to the neutral wire, use these instructions. If your local codes or ordinances do not allow the connection of a frame-grounding conductor to the neutral wire, use the instructions under **Section 3: Optional 3-wire connection.**

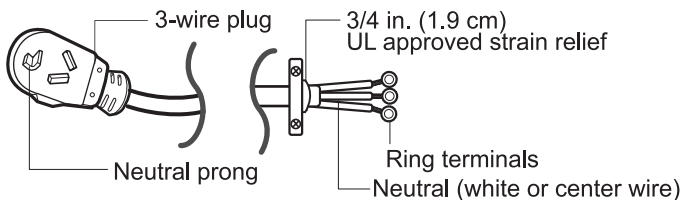
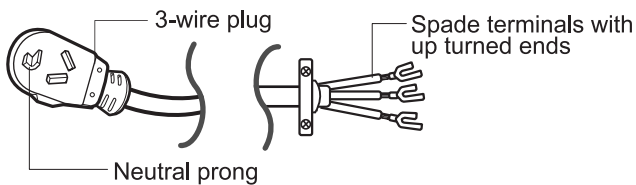
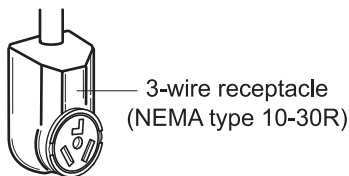

1. Connect the neutral (white or center) wire (B) to the center, silver colored, screw (A) and tighten securely.
2. Connect the other two power cord wires (red and black) to the left and right terminal block screws and tighten securely.
3. Tighten the strain relief screws (C) securely.

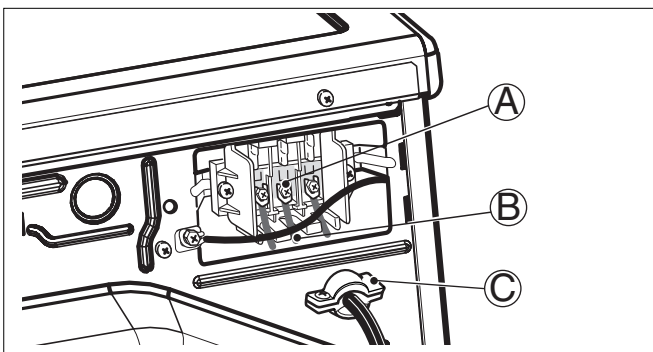

Option 3: Optional 3-wire connection.

- If your local codes or ordinances do not allow the connection of a frame-grounding conductor to the neutral wire, use the instructions under this section.

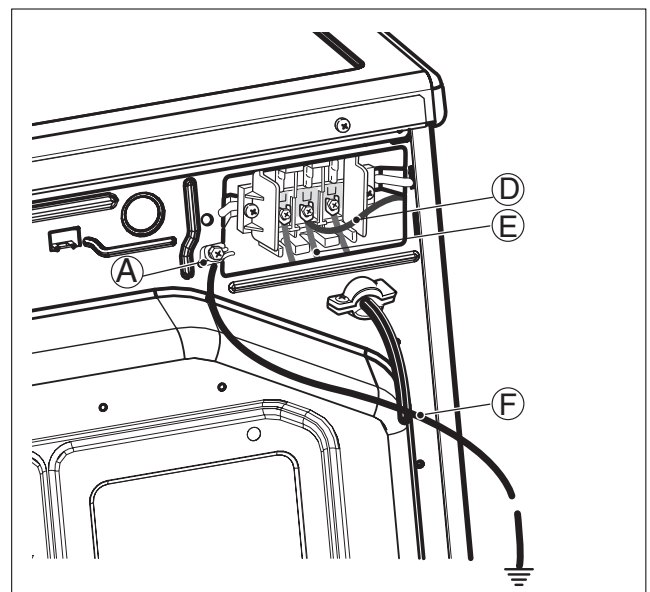
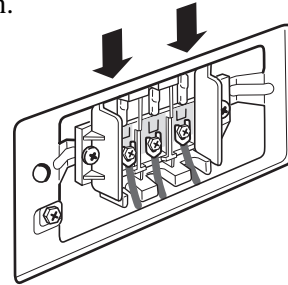

1. Remove the appliance ground wire (D) (green) from the external ground connector screw and reconnect it, together with the center, white, neutral wire (E) to the center, silver colored, terminal block screw.
2. Connect the other two power cord wires (red and black) to the left and right terminal block screws and tighten securely.
3. Tighten the strain relief screws securely.
4. Connect an independent ground wire (F) from the external ground connector screw to a proper ground. (The ground wire must be long enough to allow the appliance to be moved, if necessary, for service or cleaning.)

3-2. Connect Gas Supply Pipe (Gas Dryer ONLY)

For further assistance, refer to section on **Gas Requirements**.

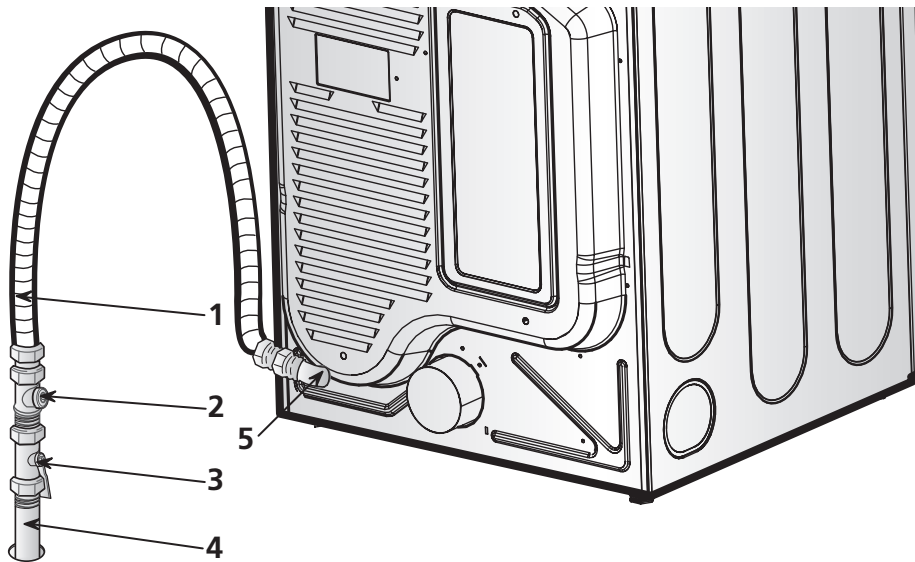

1. Make certain your dryer is equipped for use with the type of gas in your laundry room. Dryer is equipped at the factory for Natural Gas with a 3/8" N.P.T. gas connection.
2. Remove the shipping cap from the gas connection at the rear of the dryer. Make sure you do not damage the pipe thread when removing the cap.
3. Connect to gas supply pipe using a new flexible stainless steel connector.
4. Tighten all connections securely. Turn on gas and check all pipe connections (internal & external) for gas leaks with a non-corrosive leak detection fluid.
5. For L.P. (Liquefied Petroleum) gas connection, refer to section on Gas Requirements.



- 1 New Stainless Steel Flexible Connector - Use only if allowed by local codes (Use Design A.G.A. Certified Connector)
- 2 1/8" N.P.T. Pipe Plug (for checking inlet gas pressure)
- 3 Equipment Shut-Off Valve-Installed within 6' (1.8 m) of dryer
- 4 Black Iron Pipe
Shorter than 20' (6.1 m) - Use 3/8" pipe
Longer than 20' (6.1 m) - Use 1/2" pipe
- 5 3/8" N.P.T. Gas Connection

4

DRYER CYCLE PROCESS

Cycle		Default			Conditions of operation and termination				
		Temp-erature	Dry Level	Display time	Drying		Cooling		Wrinkle care
					Electro-sensor	Temp-control	Default time	Temp-Control**	Time
Sensor Dry *	HEAVY DUTY	HIGH	(Normal)	54min	Saturation	68±4℃	(5min)	47±5℃	3Hr
	COTTON/TOWELS	MID HIGH	(Normal)	55min	Saturation	66±4℃	(5min)	47±5℃	
	NORMAL	MEDIUM	(Normal)	41min	Saturation	60±4℃	(5min)	47±5℃	
	PERM PRESS	LOW	(Normal)	36min	Saturation	52±3℃	(5min)	47±5℃	
	DELICATES	LOW	(Normal)	32min	Saturation	52±3℃	(5min)	38±5℃	
	STEAM FRESH™	MID HIGH	-	20min	Saturation	66±4℃	(1min)	47±5℃	
	STEAM SANITARY™	HIGH	-	39min	Saturation	68±4℃	(5min)	47±5℃	
Manual Dry **	SPEED DRY	(HIGH)	-	25min	Saturation	(70±5℃)	(5min)	47±5℃	3Hr
	AIR DRY	-	-	30min	Saturation	No heater	N/A	N/A	
Load					Motor				Off Time: 6min
					Heater				On Time: 10sec
					Temperature Control for each cycle				

* Sensor dry : "Dry Level" is set by users.

** Manual dry : "Temperature control" is set by users.

Default settings can be adjusted by users.

5

COMPONENT TESTING INFORMATION

⚠ CAUTION When checking the Component, be sure to turn the power off, and do voltage discharge sufficiently.

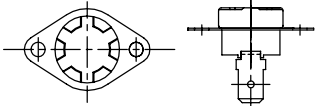
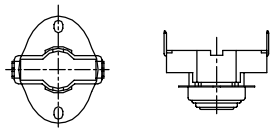
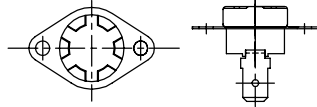
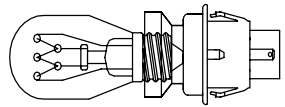
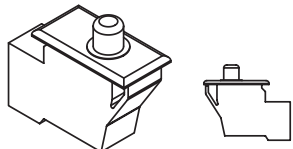
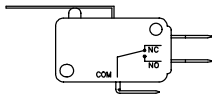
Component	Test Procedure	Check result	Remark
1. Thermal cut off  • Check Top Marking: N130	Measure resistance of terminal to terminal ① Open at $266 \pm 12^{\circ}\text{F}$ ($130 \pm 7^{\circ}\text{C}$) ② Auto reset 31°F (35°C) Same shape as Outlet Thermostat.	If thermal fuse is open must be replaced ① Resistance value $\approx \infty$ ② Continuity ($250^{\circ}\text{F} \downarrow$) $< 1\Omega$	<ul style="list-style-type: none"> • Heater case-Safety • Electric type
2. Hi limit Thermostat (Auto reset) 	Measure resistance of terminal to terminal ① Open at $257 \pm 9^{\circ}\text{F}$ ($125 \pm 5^{\circ}\text{C}$) ② Close at $221 \pm 9^{\circ}\text{F}$ ($105 \pm 5^{\circ}\text{C}$)	① Resistance value $\approx \infty$ ② Resistance value $< 5\Omega$	<ul style="list-style-type: none"> • Heater case - Hi limit • Electric type
3. Outlet Thermostat (Auto reset)  • Check Top Marking: N85	Measure resistance of terminal to terminal ① Open at $185 \pm 9^{\circ}\text{F}$ ($85 \pm 5^{\circ}\text{C}$) ② Close at $149 \pm 9^{\circ}\text{F}$ ($65 \pm 5^{\circ}\text{C}$) Same shape as Thermal cut off.	① Resistance value $\approx \infty$ ② Resistance value $< 5\Omega$	<ul style="list-style-type: none"> • Blow housing - Safety • Electric type
4. Lamp holder 	Measure resistance of terminal to terminal	Resistance value: $80\Omega \sim 100\Omega$	
5. Door switch 	Measure resistance of the following terminal 1) Door switch knob: open ① Terminal: "COM" - "NC" (1-3) ② Terminal: "COM" - "NO" (1-2) 2) Door switch push: push ① Terminal: "COM" - "NC" (1-3) ② Terminal: "COM" - "NO" (1-2)	① Resistance value $< 1\Omega$ ② Resistance value $\approx \infty$ ① Resistance value $\approx \infty$ ② Resistance value $< 1\Omega$	The state that Knob is pressed is opposite to Open condition.
6. Idler switch 	Measure resistance of the following terminal: "COM - NC"	1. lever open ① Resistance value $< 1\Omega$ 2. Lever push (close) ② Resistance value $\approx \infty$	

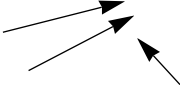
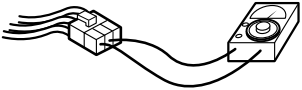
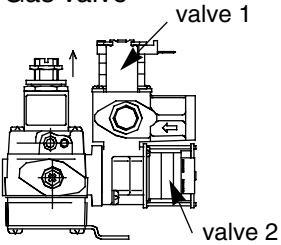
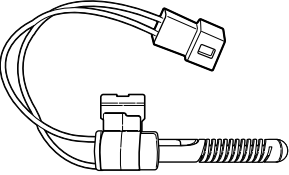
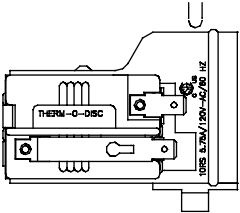
Component	Test Procedure	Check result	Remark
7. Heater 	Measure resistance of the following terminal ① Terminal: 1 (COM) - 2 ② Terminal: 1 (COM) - 3 ③ Terminal: 2 - 3	① Resistance value: 10Ω ② Resistance value: 10Ω ③ Resistance value: 20Ω	¥ Electrictype
8. Thermistor 	Measure resistance of terminal to terminal Temperature condition: 58jF ~ (10~40jC) 58jF ~ 104F (10~40jC)	Resistance value: 10Ω	¥ Heatercase - Hi limit ¥ Electrictype
9. Motor			¥See Page 13
10. Gas valve 	Measure resistance of the following terminal ① Valve 1 terminal ② Valve 2 terminal	① Resistance value: > 2.3kΩ ② Resistance value: > 2.3~2.7kΩ	¥ Gastype
11. Igniter 	Measure resistance of terminal to terminal	Resistance value: 100~800Ω	¥ Gastype
12. Frame Detect 	Measure resistance of terminal to terminal ① Open at 370jF ((Maximum) ② Close at 320jF	① Resistance value ② Resistance value < 1	¥ Gastype

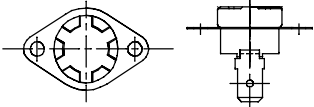
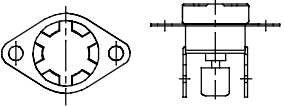
Component	Test Procedure	Check result	Remark
<p>13. Outlet Thermostat (Auto reset)</p>  <p>• Check Top Marking: N95</p>	<p>Measure resistance of terminal to terminal</p> <p>① Open at $203 \pm 7^{\circ}\text{F}$ ($95 \pm 5^{\circ}\text{C}$)</p> <p>② Close at $158 \pm 9^{\circ}\text{F}$ ($70 \pm 5^{\circ}\text{C}$)</p>	<p>① Resistance value $\neq \infty$</p> <p>② Continuity $< 1\Omega$</p>	<ul style="list-style-type: none"> • Gas type • Gas funnel
<p>14. Outlet Thermostat (Manual reset)</p>  <p>• Check Top Marking: N100</p>	<p>Measure resistance of terminal to terminal</p> <p>① Open at $212 \pm 12^{\circ}\text{F}$ ($100 \pm 7^{\circ}\text{C}$)</p> <p>② Manual reset</p>	<p>If thermal fuse is open must be replaced</p> <p>① Resistance value $\neq \infty$</p> <p>② Continuity $< 1\Omega$</p>	<ul style="list-style-type: none"> • Gas type • Gas funnel

6

MOTOR DIAGRAM AND SCHEMATIC

NOTE When checking Component, be sure to turn Power off, then do voltage discharge sufficiently.

■ Contact On / Off by Centrifugal Switch

Terminal No		①	②	③	④	⑤	⑥	Remark
Mode	Resistance							
Motor STOP	2 ~ 3Ω				●—●			Motor
	≒ ∞	●—●						Heater (Electric Models)
	≒ ∞			●—●				Gas Valve (Gas Models)
Motor RUN	3 ~ 5Ω				●—●			Motor
	< 1Ω	●—●						Heater (Electric Models)
	< 1Ω			●—●				Gas Valve (Gas Models)

..... Open
 ——— Close

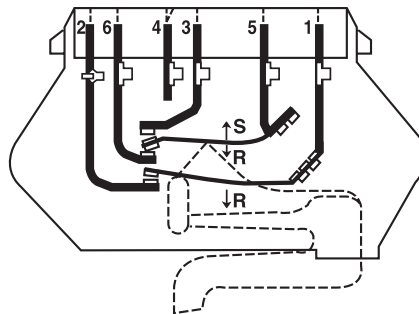

SWITCH SHOWN IN START POSITION

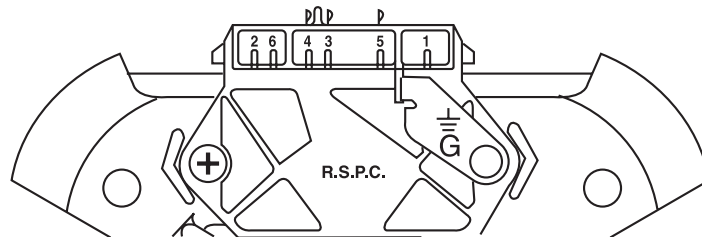

■ STOP MODE
 (When Motor does not operate)

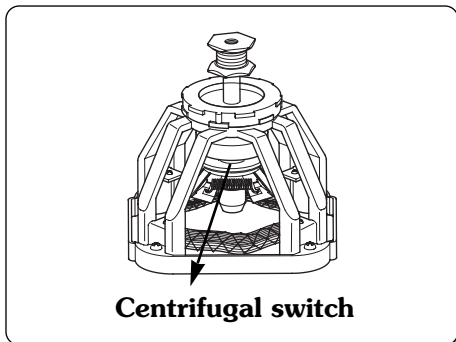

■ RUN MODE
 (Motor operates)

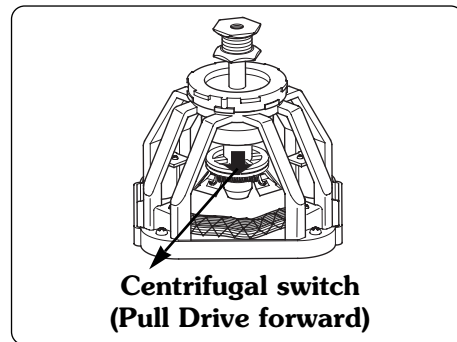

ELECTRIC DRYER WIRING DIAGRAM

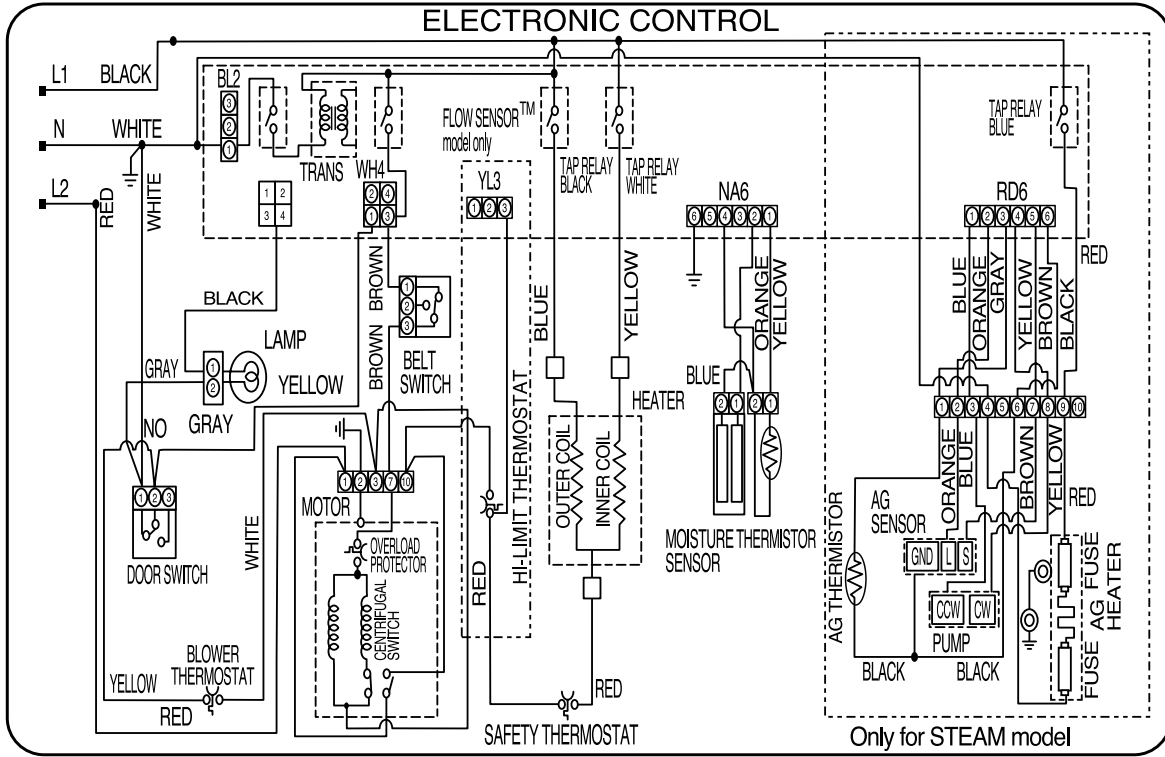

GAS DRYER WIRING DIAGRAM

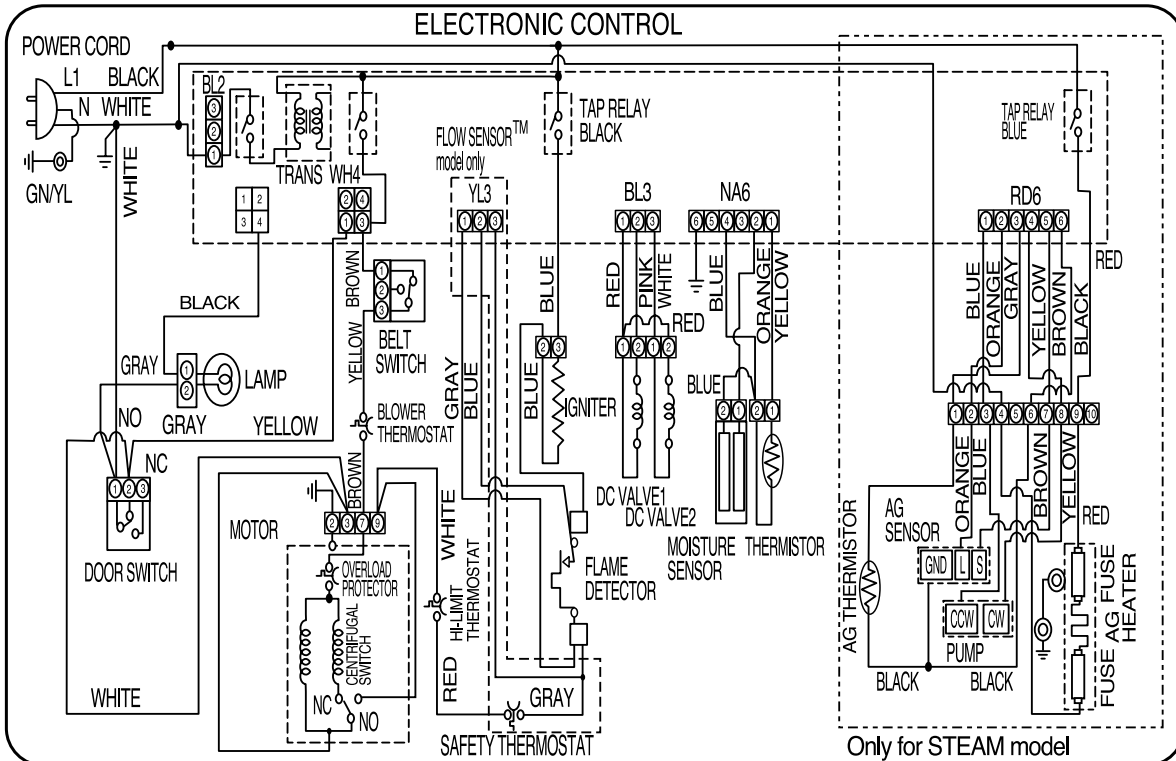

8-1. Steam Cycle Guide

	STEAM	DEFAULT TIME	TEMP. CONTROL	DRY LEVEL	FABRIC STATE	FABRIC TYPE	MAXIMUM AMOUNT
STEAMSANITARY		39 minutes			Dry	Comforter Bedding	Single (1 each)
						Children's clothing	3 lbs.
STEAMFRESH		20 minutes	O		Dry	Comforter Shirts*	Single (1 each) 5 each
	+ REDUCE STATIC	10 minutes Only reduce static			Dry	Shirts*	8 lbs. (18 Items.)
	+ EASY IRON	12 minutes			Dry		Shirts* (5 each)
HEAVY DUTY COTTON/TOWELS NORMAL PERM.PRESS DELICATES	+ REDUCE STATIC	Follow selected cycle		O	Wet	Follow selected cycle	8 lbs. (18 Items.)
	+ EASY IRON			O	Wet	Follow selected cycle	Shirts* (5 each)
TIME DRY	+ REDUCE STATIC	45 minutes	O		Wet	Follow selected temp	8 lbs. (18 Items.)
	+ EASY IRON	47 minutes	O		Wet	Follow selected temp	Shirts* (5 each)

*Shirt: 70% cotton/30% poly blend. Except especially delicate fabrics.

- When the lint filter or exhaust duct is clogged, steam options will not give proper results.
- For best results, load articles of similar size and fabric type. Do not overload.

IMPORTANT NOTES ABOUT STEAM CYCLES:

- The steam feeder must be filled with water up to the MAX line. Otherwise, an error message will be displayed.
- If the lint filter or exhaust duct is clogged, the Steam options will not give proper results.
- For best results, load articles of similar size and fabric type.
Do not overload.
- Water only - Do not add any additives or other materials as these will damage your dryer.
- Before moving the dryer, make sure the steam feeder is empty.
- Best results are obtained with cotton/poly blend fabrics.

8-2. Troubleshooting for Steam Dryer

PROBLEM	POSSIBLE CAUSES	SOLUTIONS
ADD WATER indicator light is on during the drying cycle	<ul style="list-style-type: none"> • Water supply error. 	<ul style="list-style-type: none"> • Check steam feeder drawer: <ol style="list-style-type: none"> (1) Make sure steam feeder is filled with water to MAX line. (2) Make sure steam feeder is seated properly and drawer is fully closed. (3) Turn the dryer off then restart the Steam cycle. • Do not use distilled water; the water level sensor in steam generator will not work. • Pump not working. Unplug dryer and call for service.
Water drips from nozzle when Steam Cycle starts.	<ul style="list-style-type: none"> • This is normal. 	<ul style="list-style-type: none"> • This is steam condensation. The dripping water will stop after a short time.
Steam doesn't generate but no error code is shown.	<ul style="list-style-type: none"> • Water level error. 	<ul style="list-style-type: none"> • Unplug dryer and call for service.
Garments still wrinkled after STEAM REFRESH.	<ul style="list-style-type: none"> • Too many or too different types of garments in dryer. 	<ul style="list-style-type: none"> • Small loads of 1 to 5 items work best. • Load fewer garments. Load similar-type garments.
There are no creases left on garment after STEAM REFRESH.	<ul style="list-style-type: none"> • The function of this cycle is to remove wrinkles from fabric. 	<ul style="list-style-type: none"> • Use an iron to make creases.
Garments have static after STATIC SHIELD.	<ul style="list-style-type: none"> • This is normal. 	<ul style="list-style-type: none"> • Depends on individual moisture level in skin.
Garments are too damp or too dry after STATIC SHIELD.	<ul style="list-style-type: none"> • Correct drying options not selected. 	<ul style="list-style-type: none"> • Select load weight manually before starting REDUCE STATIC option.
Water drips from door during Steam Cycle.	<ul style="list-style-type: none"> • This is normal. 	<ul style="list-style-type: none"> • This is steam condensation on door surface.
Steam is not visible during Steam Cycle.	<ul style="list-style-type: none"> • This is normal. 	<ul style="list-style-type: none"> • Steam vapor is difficult to see when the door is closed.
Drum does not turn during Steam Cycle.	<ul style="list-style-type: none"> • This is normal. 	<ul style="list-style-type: none"> • The drum is turned off so that the steam vapor remains in the drum.

PROBLEM	POSSIBLE CAUSES	SOLUTIONS
Cannot see steam vapor at the beginning of cycle.	<ul style="list-style-type: none"> This is normal. 	<ul style="list-style-type: none"> Steam is released at different stages of the cycle for each option.
The display shows BULKY LOAD.	<ul style="list-style-type: none"> MORE TIME button pressed. 	<ul style="list-style-type: none"> Pressing the MORE TIME button several times will set the cycle for a large load such as a comforter.
Odors remain in clothing after STEAM REFRESH.	<ul style="list-style-type: none"> STEAM REFRESH did not remove odor completely. 	<ul style="list-style-type: none"> Fabrics containing strong odors should be washed in a normal cycle.

8-3. Display Fault/Error Codes for Steam Dryer

The error codes below will be displayed when attempting to start a drying cycle, or after activating the Diagnostic Test mode.

DISPLAY	CHECKING PART	CAUSE	REMARK
tE1	Thermistor of blower housing	Outlet thermistor open or shorted.	<ul style="list-style-type: none"> tE1 error is displayed in the drying cycle or test mode. Replace the steam generator.
tE2	Thermistor of blower housing	Outlet thermistor open or shorted.	<ul style="list-style-type: none"> tE2 error is displayed in the drying cycle or test mode. Replace the steam generator.
tE4	Thermistor of steam generator	Steam generator thermistor open or shorted.	<ul style="list-style-type: none"> tE4 error is only displayed in the test mode. Replace the steam generator.
E5	Water supply pump	When the pump valve is less than 10 in the test mode	<ul style="list-style-type: none"> tE5 error is only displayed in the test mode. Check the connection between harness wire and connector. Replace the water supply pump.
Add water	Steam generator	Sensors do not detect that steam generator is full within 60 seconds.	<ul style="list-style-type: none"> If water in the steam feeder is not enough this error may be displayed. Fill the feeder and restart the cycle.
PS	Wire Connection (Black-White-Red)	Wire Connection is wrong. Wire Connection is loose.	<ul style="list-style-type: none"> See the 9-11 page. Guidance of the wire connection. For only electric dryer. *PS : "Power Supply"

9-1 Flow sensor

This FlowSense™ function detects the clogging or blocking of ducts.

“Clogged” duct vents or hoses decrease efficiency in drying cloths. Clogged vents can also cause fire.

This function alarms you, when to clean the ducts.

When the alarm about Duct clogging is on display of the panel, your duct vents should be cleaned by yourself or serviceman.

Flow Sensor Function



9-2 Installation check

This feature allows you to quickly verify that the exhaust system is adequate for the normal function of the dryer. The check takes only two minutes. The results of the check are displayed in the FlowSense display window as shown below

(Fig. 1). The dryer must be at room temperature for this test to be reliable. To perform this test, start the machine in standby mode (power off). Press and hold both the **DAMP DRY BEEP** and the **TEMP CONTROL** buttons together while turning on the dryer with the **POWER** button i.e. Press together the three buttons **DAMP DRY BEEP + TEMP CONTROL + POWER**. The dryer will start and run for 2 minutes while it checks temperatures. At the end of this short cycle, it will display the results as follows.

Fig.1

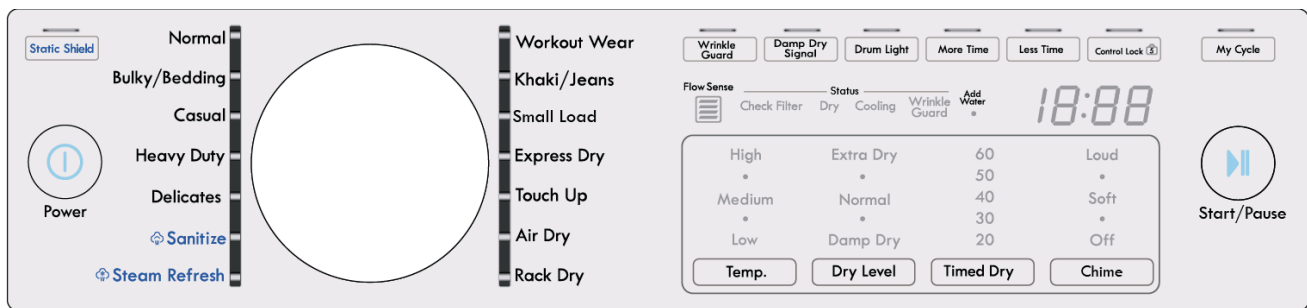

**PRESS TOGETHER
(Three buttons)**

After Installation Check,
If the display shows....

OR



If "YES" is shown in the display, the ductwork is free from blockages or restrictions.

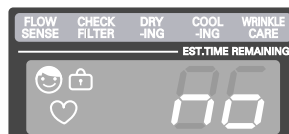

If "no" is shown in the display, the dryer ductwork has a blockage that needs to be removed immediately.

9-3 Troubleshooting for flow sensor dryer

1. FLOW SENSE indicator light is on

Is Lint Filter full?



Clean lint filter before every load



Is Duct clogged?



Check & clean duct.

2. FLOW SENSE indicator light is on and does not disappear.

1. FLOW SENSE indicator light is on even when vents have been clean and even when the vents are off.
 → **This is Normal.** After Flow sensor Recheck Full Next Cycle, Flow sensor is Reset.
 (Flow sensor bars will disappear after Dryer has operated two cycle)

■ Displayed and Don't disappear Bars

*Control Panel



Make sure that the ductwork is not crushed or restricted.

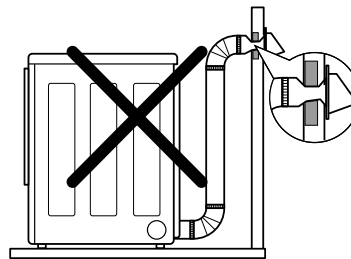

Avoid long runs of ducts or runs with multiple elbows or bends.

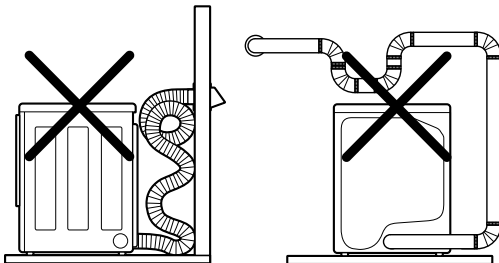

Check for blockages and lint build up.

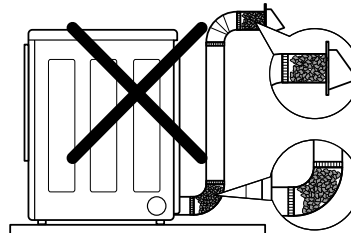

1. This TEST should be used for Factory test /Service test. Do not use this DIAGNOSTIC TEST other than specified.
2. Activating the Heater manually with the Door open may trip the Thermostat attached to the Heater, therefore do not activate it manually. (Do not press the door switch to operate the heater while the door is open)

■ ACTIVATING THE DIAGNOSTIC TEST MODE

1. UNIT must be in standby (unit plugged in, display off)
2. Press POWER while pressing MORE TIME and LESS TIME simultaneously.
3. Press START/PAUSE button to advance through diagnostics.

Pressing the START/PAUSE	CHECKING ACTION	DISPLAY	CHECKPOINT
None	Electric control & Temperature sensor	8E9(Elec Type) 898(Gas Type)	Standard
		V00	PGM Ver (8E8-V008E8)
		tE1	Thermistor open
		tE2	Thermistor shorted
		tE4	AG Thermistor open or shorted
Once	Motor+Controller	30 = Low moisture 239 = High moisture	Motor runs Displays Moisture Sensor Operation : If moisture sensor is contacted with damp cloth. The display number is below 180 in normal condition
Twice	<ul style="list-style-type: none"> ■ ELECTRIC TYPE Motor+Heater1(2700W) ■ GAS TYPE Motor+Gasvalve 	Current Temp. (5~70)	<ul style="list-style-type: none"> ■ ELECTRIC TYPE Heater 1 is energized - 2700 W ■ GAS TYPE Valve runs (Temperature in the drum is displayed in degrees C.)
3 times	<ul style="list-style-type: none"> ■ ELECTRIC TYPE Motor+Heater1+Heater2 (5400W) ■ GAS TYPE Motor+Gasvalve 	Current Temp. (5~70)	<ul style="list-style-type: none"> ■ ELECTRIC TYPE: Heater 1 and heater 2 are energized - 5400 W ■ GAS TYPE: Gas valve is energized (Temperature in the drum is displayed in degrees C.)
4 times	Motor+Pump+ Heater2(runs for 1sec) (Heater1 off)	Pump AD valve (11~255)	Pump runs
		E5	Pump Error
5 times	Motor,Pump,Heater2 off	OO	
6 times	Loads, Controller off		Power off

* To check pump operation:

When pressed 4 times in the test mode, If the AD value of the pump is higher than 10 on the display, the pump is normal. If it is lower than 10, E5 error will be displayed.

■ Test 1 120V AC Electrical supply

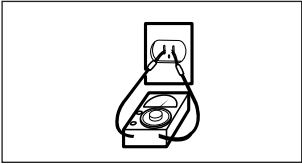
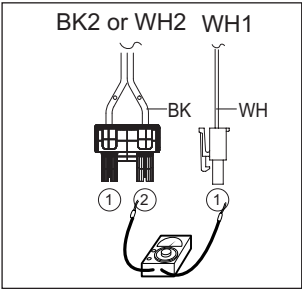
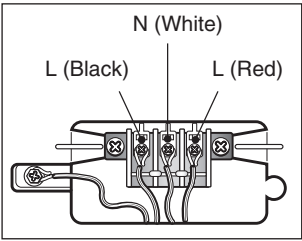
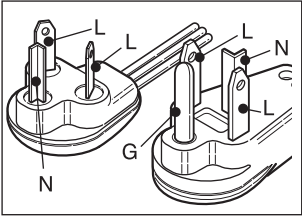
Caution	When measuring power, be sure to wear insulated gloves, to and avoid an electric shock.	
Trouble Symptom	No power was applied to Controller. (LED,LCD Display off)	
Measurement Condition	With Dryer Power On; Connector linked to Controller.	
<div style="display: flex; flex-direction: column; align-items: center;"> <div style="display: flex; justify-content: space-between; width: 100%; margin-bottom: 20px;"> <div style="width: 25%; text-align: center;">  </div> <div style="width: 50%; border: 1px solid black; padding: 10px;"> <p>Check the outlet, is the voltage 110V ~ 125V AC?</p> </div> <div style="width: 20%; text-align: center;"> <p>NO</p> </div> </div> <div style="display: flex; justify-content: space-between; width: 100%; margin-bottom: 20px;"> <div style="width: 25%;"></div> <div style="width: 50%; text-align: center;"> <p>YES</p> </div> <div style="width: 20%;"></div> </div> <div style="display: flex; justify-content: space-between; width: 100%; margin-bottom: 20px;"> <div style="width: 25%; text-align: center;">  </div> <div style="width: 50%; border: 1px solid black; padding: 10px;"> <p>Check if the voltage measured between Connector BK2 or WH2-② (Black Wire) Linked to the Controller and WH1-① (White Wire) Is 110~125V?</p> </div> <div style="width: 20%; text-align: center;"> <p>NO</p> </div> </div> <div style="display: flex; justify-content: space-between; width: 100%; margin-bottom: 20px;"> <div style="width: 25%;"></div> <div style="width: 50%; text-align: center;"> <p>YES</p> </div> <div style="width: 20%;"></div> </div> <div style="display: flex; justify-content: space-between; width: 100%; margin-bottom: 20px;"> <div style="width: 25%; text-align: center;">  </div> <div style="width: 50%; border: 1px solid black; padding: 10px;"> <p>① Check if the Controller wire is disconnected. ② Check if Terminal Block and Power Cord are connected (Check Plug). - Does Power Cord N (Natural) line match to Terminal Center N (Natural) line?</p> </div> <div style="width: 20%; text-align: center;"> <p>NO</p> </div> </div> <div style="display: flex; justify-content: space-between; width: 100%; margin-bottom: 20px;"> <div style="width: 25%;"></div> <div style="width: 50%; text-align: center;"> <p>YES</p> </div> <div style="width: 20%;"></div> </div> <div style="display: flex; justify-content: space-between; width: 100%;"> <div style="width: 25%; text-align: center;">  </div> <div style="width: 50%; border: 1px solid black; padding: 10px; text-align: center;"> <p>Replace controller.</p> </div> <div style="width: 20%;"></div> </div> </div> <div style="display: flex; justify-content: space-between; width: 100%; margin-top: 20px;"> <div style="width: 25%;"></div> <div style="width: 50%;"></div> <div style="width: 20%; text-align: center;"> <p>NO</p> <p>• Check the fuse or circuit breaker.</p> </div> </div> <div style="display: flex; justify-content: space-between; width: 100%; margin-top: 20px;"> <div style="width: 25%;"></div> <div style="width: 50%;"></div> <div style="width: 20%; text-align: center;"> <p>NO</p> <p>• Check if Power Cord is properly connected.</p> </div> </div> <div style="display: flex; justify-content: space-between; width: 100%; margin-top: 20px;"> <div style="width: 25%;"></div> <div style="width: 50%;"></div> <div style="width: 20%; text-align: center;"> <p>NO</p> <p>• Reconnect the controller.</p> </div> </div>		

Caution	When measuring power, be sure to wear insulated gloves, to and avoid an electric shock.
Trouble Symptom	Check the Tab Relays Connection properly.
Measurement Condition	With Dryer Power On; Connector linked to Controller.

1. Power Connection

< Table1 > : Connection of the Tab Relay with Heater (Elec)

	Tab Relay 1	Tab Relay 2	Heater 1	Heater 2	Remark
High Mid High Medium	on	on	on	on	Temperature Control below $68 \pm 4^\circ\text{C}$. Turn on Heater1 and Heater2.
Low Extra Low	on	off	on	off	Temperature Control below $52 \pm 4^\circ\text{C}$. Only Turn on Heater1.

< Table 2 > : Connection of the Tab Relay with Burner (Gas)

	Tab Relay 1	Burner	Remark
High Mid High Medium	○	○	Temperature Control below $70 \pm 4^\circ\text{C}$. Turn on Burner
Low Extra Low	○	○	Temperature Control below $47 \pm 4^\circ\text{C}$. Turn on Burner

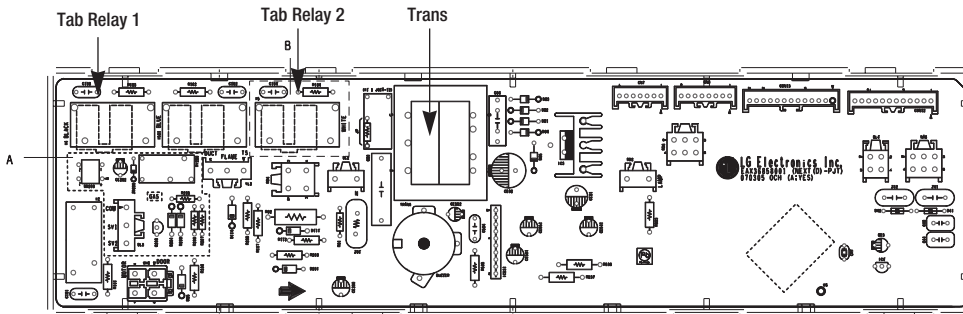

* PCB ASSEMBLY LAYOUT

2. Status Mode Of The Connection

< Table1 > : Connection of Tab Relay with the Tab Relay of the PCB ASSEMBLY (Elec)

	Color	Connection		Remark
		Harness	PCB	
Connector Housing	Black			Check the Matching color Between Harness wire and Tab Relay. (Black Housing – Black Tab Relay)
	White			

< Table 2 > : Connection of Tab Relay with PCB ASSEMBLY (Gas)

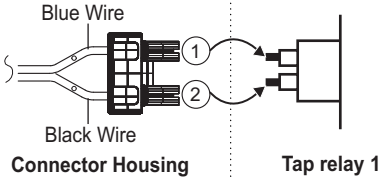
	Color	Harness	PCB	Remark
Connector Housing	Black			Check the Matching color Between Harness wire and Tab Relay. (Black Housing – Black Tab Relay)

3. Status Mode Of wrong Connection

< Table1 > : Wrong Connection of the Tab Relay and Connector Housing (Elec)

Items	Case	Heater1 Operation(black)	Heater2 operation(White)	PCB condition Of operation
1.Black and White Housing	Wire ①, ② CROSS	Off	Off	Power Off
2.Black Housing	Wire ①, ② CROSS	Off	Off	Power Off
3.White Housing	Wire ①, ② CROSS	Normal	Normal	Power On
* 4.Black and White Housing	Housing CROSS	Heater2	Heater1	Power On
5.Black and White Housing	Housing and Wire ①, ② CROSS	Off	Off	Power Off

< Table2 > : Wrong Connection of the Tab Relay and Connector Housing (Gas)

Items	Case	Heater1 Operation(black)	Heater2 operation(White)	PCB condition Of operation
1.Black and White Housing	Wire ①, ② CROSS	Off	Off	Power Off

⚠ CAUTION

- In case of power failure(<Table1>-1,2,5,<Table2>-1), Please check the Connection of "2.Status Table of Connection".
 In case of power failure(<Table1>-4), please check the Connection of "2. Status Table of Connection". Because improper Connection of the equipment-dryer can be damaged of changing heater.

■ Test 2 Thermistor Test --- Measure with Power Off

Caution	Before measuring resistance, be sure to turn Power off, and do voltage discharge. (When discharging, contact the metal plug of Power cord with the Ground.)
Trouble Symptom	<ol style="list-style-type: none"> ① During Diagnostic Test, tE1 and tE2 Error occur. ② During operation, Heater would not turn off, or remains on. ③ Difference between actual and sensed temperature is significant.
Measurement Condition	After turning Power off, measure the resistance.

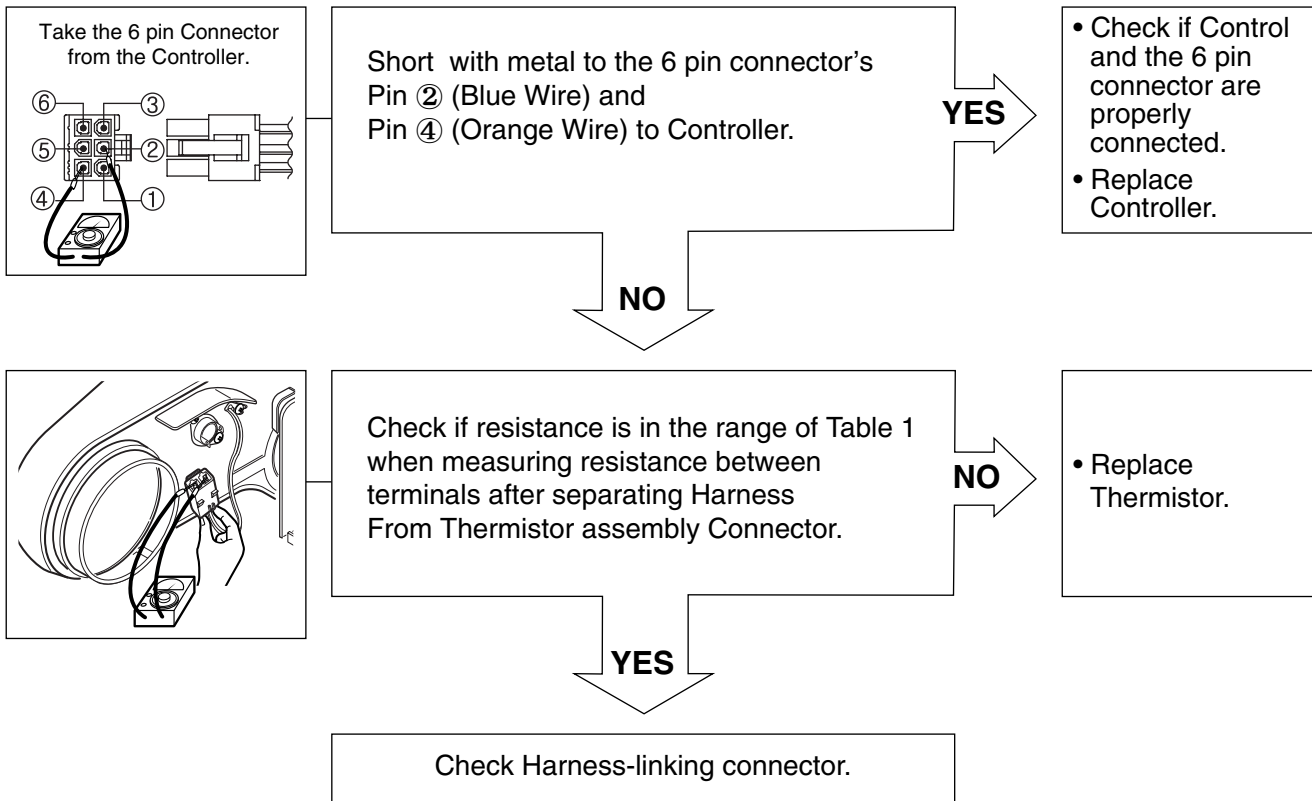

■ Table 1. Resistance for Thermistor Temperature.

Air TEMP.[°F (°C)]	RES. [kΩ]	Air TEMP.[°F (°C)]	RES. [kΩ]	Air TEMP.[°F (°C)]	RES. [kΩ]
50°F (10°C)	18.0	90°F (32°C)	7.7	130°F (54°C)	2.9
60°F (16°C)	14.2	100°F (38°C)	6.2	140°F (60°C)	3.0
70°F (21°C)	11.7	110°F (43°C)	5.2	150°F (66°C)	2.5
80°F (27°C)	9.3	120°F (49°C)	4.3	160°F (71°C)	2.2

■ Test 3 Motor test

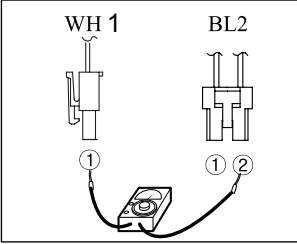
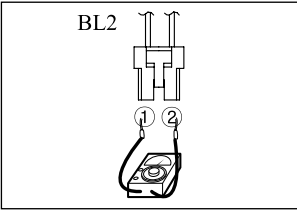
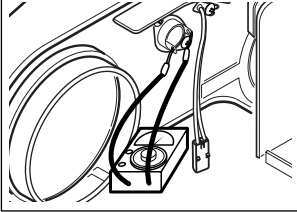
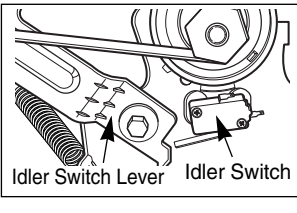
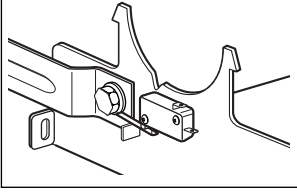
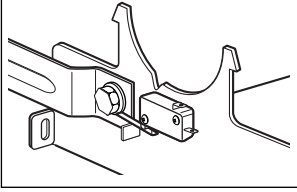
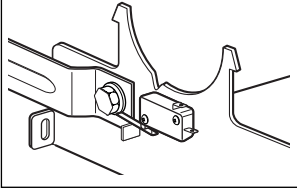
<p>Caution</p>	<p>Before measuring resistance, be sure to turn Power off, and do voltage discharge. (When discharging, contact the metal plug of Power cord with earth line.)</p>		
<p>Trouble Symptom</p>	<p>Drum will not rotate; No fan will function; No Heater will work.</p>		
<p>Measurement Condition</p>	<p>Turn the Dryer's Power Off, then measure resistance.</p>		
	<p>Is resistance below 3Ω between Connector WH① (White wire) and BL2-② (Brown wire)? ※ Measure while door is closed.</p>	<p>YES</p>	<ul style="list-style-type: none"> • Replace Control. (Relay check) • Check Controller connector.
	<p>Is resistance below 3Ω between Connector WH① (White wire) and BL2-① (Yellow wire)? ※ Measure while door is closed.</p>	<p>NO</p>	<ul style="list-style-type: none"> • Check if Door flame presses door switch knob. • Check Door Switch. • Check Harness connection.
	<p>Is resistance below 3Ω between Connector BL2-① (Yellow wire) and BL2-② (Brown wire)?</p>	<p>YES</p>	<ul style="list-style-type: none"> • Replace Control. (Relay check) • Check Controller connector.
	<p>Is resistance below 1Ω between terminals of Outlet Thermostat attached to blower housing?</p>	<p>NO</p>	<ul style="list-style-type: none"> • Replace Outlet • Thermostat. (Refer to 'Component')
	<p>Does Idle Switch attached to Motor Bracket operate Level by drum belt? (Not operating Lever is normal.)</p>	<p>YES</p>	<ul style="list-style-type: none"> • Check Idler Assembly. • Drum Belt cuts off • Drum Belt takes off from Motor Pulley.
	<p>Is resistance below 1Ω between Idler Switch terminals?</p>	<p>NO</p>	<ul style="list-style-type: none"> • Replace Idler Switch.
	<p>• Check Motor. (Refer to 'Motor Diagram & Check')</p> <p>• Check if Control Connector is contacted.</p>	<p>YES</p>	

■ Test 4 Moisture sensor

Caution	Before measuring resistance, be sure to turn Power off, and do voltage discharge. (When discharging, contact the metal plug of Power cord with earth line.)
Trouble Symptom	Degree of dryness does not match with Dry Level.
Measurement Condition	Turn the Dryer's Power Off, then measure resistance.

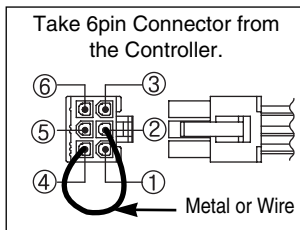

Short with metal to the 6 pin connector's Pin ② (Blue Wire) and Pin ④ (Orange Wire) to Controller.

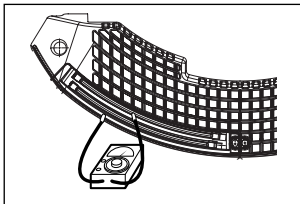

When measuring resistance in Electric load, is resistance below 1Ω ?

NO

- Check Electro Load and Harness Connector.
- Check Harness-linking connector.

YES

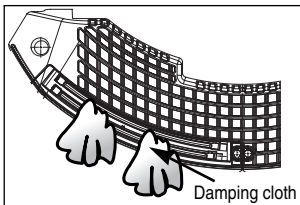

When contacting cloth to Electro load:
 1. Is the measurement within the range of Table 2 during Diagnostic Test?
 2. Is the measurement within the range of Table 2 when measuring the voltage in the 6 pin connector's Pin ③ (BLUE wire) and Pin ⑤ (ORANGE wire)?

NO

- Replace Control and Check.



YES

Normal Condition

■ Table 2. IMC Ratio and Display Value / Voltage (IMC: Initial Moisture Content)

IMC	Display Value	Voltage (DC) (between 6 Pin terminal ③,⑤)	Remark
70% ~ 40%	50 ~ 130	2.5V	Weight after removing from Washing Machine
40% ~ 20%	130 ~ 20	2.0V ~ 4.0V	Damp Dry
10% ~ Dried clothes	205 ~ 240	Over 4.0V	Completely-dried clothes

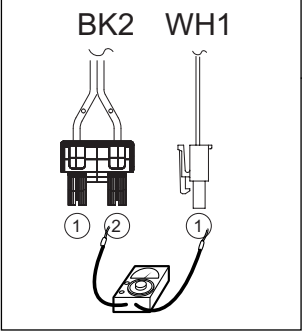
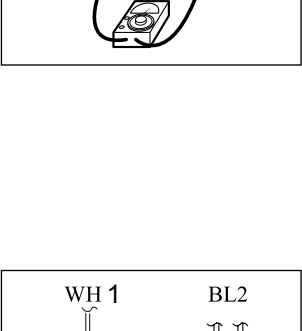
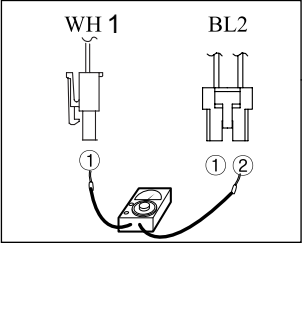
■ Test 5 Door switch test

Caution	Before measuring resistance, be sure to turn Power off, and do voltage discharge. (When discharging, contact the metal plug of Power cord with earth line.)
Trouble Symptom	Door Opening is not sensed.(During operation, when opening Door, Drum motor and Heater run continuously) Door Close is not sensed. (Drum motor will not operate. Display will flash at 0.5 second intervals.)
Measurement Condition	After turning Dryer Power Off, measure resistance.
<div style="display: flex; flex-direction: column; align-items: flex-start;"> <div style="display: flex; width: 100%; margin-bottom: 20px;"> <div style="width: 25%; text-align: center;">  <p>BK2 WH1</p> </div> <div style="width: 50%; padding: 0 10px;"> <p>Measure while Door is closed. Check it resistance is below 2500 Ω between WH1-①(White wire) and BK2-② Connector WH1,BL2 after taking WH1,BL2 out from Controller.</p> <p style="text-align: right;">YES</p> </div> <div style="width: 20%; text-align: center;"> <p>NO</p> </div> <div style="width: 25%; padding-left: 10px;"> <ul style="list-style-type: none"> • Door switch Check (Refer to Component testing.) </div> </div> <div style="display: flex; width: 100%; margin-bottom: 20px;"> <div style="width: 25%; text-align: center;">  <p>WH1 BK2</p> </div> <div style="width: 50%; padding: 0 10px;"> <p>Measure while Door is open. Check it resistance is 300~60 Ω between WH1-①(White wire) and BK2-② (Black wire). Connector WH1,BL2 after taking WH1,BL2 out from Controller.</p> <p style="text-align: right;">NO</p> </div> <div style="width: 20%; text-align: center;"> <p>NO</p> </div> <div style="width: 25%; padding-left: 10px;"> <ul style="list-style-type: none"> • Check Lamp. (When opening Lamp, replace then measure again.) • Door switch Check(Refer to Component testing.) </div> </div> <div style="display: flex; width: 100%; margin-bottom: 20px;"> <div style="width: 25%; text-align: center;">  <p>WH1 BL2</p> </div> <div style="width: 50%; padding: 0 10px;"> <p>Measure while Door is open. Check it resistance is below 1 Ω between BL2- ①(Yellow wire) and WH1-①(White wire) after taking Connector WH1,BL2 out from Controller.</p> <p style="text-align: right;">YES</p> </div> <div style="width: 20%; text-align: center;"> <p>NO</p> </div> <div style="width: 25%; padding-left: 10px;"> <ul style="list-style-type: none"> • Door switch Check (Refer to Component testing.) </div> </div> <div style="display: flex; width: 100%; margin-bottom: 20px;"> <div style="width: 25%; text-align: center;">  <p>BL2 WH1</p> </div> <div style="width: 50%; padding: 0 10px;"> <p>Measure while Door is closed. Check it resistance is below 1 Ω between BL2- ①(Yellow wire) and WH1-①(White wire) after taking Connector WH1,BL2 out from Controller.</p> <p style="text-align: right;">NO</p> </div> <div style="width: 20%; text-align: center;"> <p>NO</p> </div> <div style="width: 25%; padding-left: 10px;"> <ul style="list-style-type: none"> • Door switch Check (Refer to Component testing.) </div> </div> <div style="width: 100%; text-align: center; margin-top: 20px;"> <p>YES</p> <p>Check Controller. Check Harness-linking connector.</p> </div> </div>	

■ Test 6 Heater switch test - Electric Type

Caution	Before measuring resistance, be sure to turn Power off, and do voltage discharge. (When discharging, contact the metal plug of Power cord with earth line.)	
Trouble Symptom	While operating, Heating will not work. Drying time takes longer.	
Measurement Condition	After turning Power off, measure the resistance.	
<div data-bbox="149 740 451 1038"> </div> <div data-bbox="149 1136 451 1442"> <p>■ Only for FLOW SENSE model</p> </div> <div data-bbox="149 1459 451 1766"> <p>■ Others</p> </div> <div data-bbox="149 1774 451 1934"> <p>※ Wires</p> <ul style="list-style-type: none"> • L2(Red) • L2D(White) : Go to the duct (YL3 in main pcb) • L2S(White) : Go to the safety. </div>	<div data-bbox="475 740 1101 1038"> <ol style="list-style-type: none"> 1. Is resistance between Heater terminal ① and ② below 18 ~ 22Ω? 2. Is resistance between Heater terminal ① and ③ below 18 ~ 22Ω? 3. Is resistance between Heater terminal ② and ③ below 9 ~ 11Ω? </div> <div data-bbox="475 1136 1101 1306"> <p>Check if the value of measured resistance is below 1Ω between terminal TH2 (Safety Thermostat).</p> </div> <div data-bbox="475 1336 1101 1506"> <p>Check if the value of measured resistance is below 1Ω between terminal TH3 (HI-Limit Thermostat).</p> </div> <div data-bbox="475 1536 1101 1706"> <p>Check Motor. Check if the value of measured resistance is below 1Ω between terminal ① and ⑩ at RUN condition.</p> </div> <div data-bbox="475 1800 1101 1902"> <p>Check Controller. Check Harness-linking Connector.</p> </div>	<div data-bbox="1101 740 1508 1038"> <p>NO</p> <ul style="list-style-type: none"> • Replace Heater. </div> <div data-bbox="1101 1136 1508 1306"> <p>NO</p> <ul style="list-style-type: none"> • Replace TH2 (Safety Thermostat) and TH3 (Hi-Limit thermostat) </div> <div data-bbox="1101 1336 1508 1506"> <p>NO</p> <ul style="list-style-type: none"> • Replace TH2 (Safety Thermostat) and TH3 (Hi-Limit thermostat) </div> <div data-bbox="1101 1536 1508 1706"> <p>NO</p> <ul style="list-style-type: none"> • Check Motor and replace it. </div>

■ Test 7 GAS Valve test - Gas Type

Caution	When measuring power, be sure to wear insulated gloves, to avoid electric shock.
Trouble Symptom	While operating, Heating will not work. Drying time takes longer.
Measurement Condition	With dryer power on

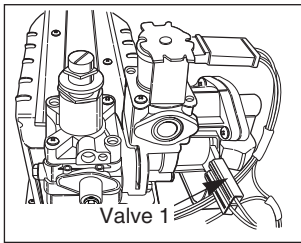

Power On & Start (Normal Cycle)

NO

When measuring Valve 1 voltage,
More than DC 90V?

NO

• Check thermostat
Hi limit Safety

YES

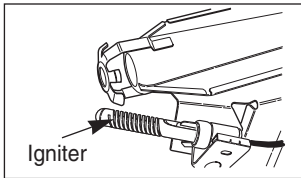

Igniter operates?
(after 1 min, Igniter becomes reddish)

NO

• Check Igniter &
Frame detect

YES

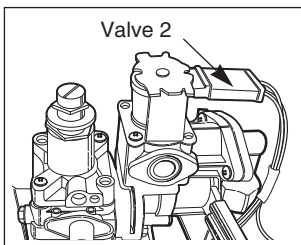

When measuring Valve 2 voltage, Value is more
than DC 90V? (10 sec after Igniter off)

YES

• Check Gas
connection or
Gas supply

NO

When measuring terminal resistance on Valve 1 and
Valve 2, Valves are more than 1.5 ~ 2.5kΩ?
(Measure after Off)

YES

• Change Valve

NO

If "Valve 1" and "Valve 2" are under DC 10V, Valves
are Off?

NO

• Change Valve

YES

• Harness check
• Controller change

NOTE: When the gas valve operates after disassembling, ignition will be off several seconds.
It is normal because there is no circulation of air.

■ Test 8 Semi Conductor

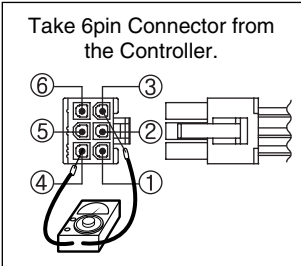
Caution	Before measuring resistance, be sure to turn Power off, and do voltage discharge. (When discharging, contact the metal plug of Power cord with earth line.)
Trouble Symptom	Degree of Resistance is not in $300 \pm 30 \Omega$
Measurement Condition	Turn the Dryer's Power Off, then measure resistance.
<div style="display: flex; align-items: center;"> <div style="border: 1px solid black; padding: 5px; margin-right: 20px;"> <p>Take 6pin Connector from the Controller.</p>  </div> <div style="border: 1px solid black; padding: 10px; flex-grow: 1;"> <p>When measuring resistance ③-④, ④-⑤ Is resistance $300 \pm 20 \Omega$?</p> <div style="display: flex; justify-content: space-around; align-items: center;"> <div style="text-align: center;"> <p>YES</p> <p>↓</p> <p style="border: 1px solid black; padding: 5px; width: 150px; text-align: center;">Normal condition</p> </div> <div style="text-align: center;"> <p>NO</p> <p>→</p> <div style="border: 1px solid black; padding: 5px; width: 150px;"> <ul style="list-style-type: none"> Check Semi-conductor and Harness Connector Check Harness linking connector </div> </div> </div> </div> </div>	

■ Test 9 Motor Assembly, DC, Pump

Caution	Before measuring resistance, be sure to turn Power off, and do voltage discharge. (When discharging, contact the metal plug of Power cord with earth line.)
Trouble Symptom	During Diagnostic Test, E5 Error occur.
Measurement Condition	Turn the Dryer's Power Off, then measure resistance.
<div style="display: flex; align-items: center; justify-content: center;"> <div style="border: 1px solid black; padding: 10px; margin-right: 20px;"> <p>After activating the *diagnostic test, press START/PAUSE button 4 times. Is AD value displayed higher than 10 ?</p> </div> <div style="text-align: center;"> <p>NO</p> <p>→</p> <div style="border: 1px solid black; padding: 5px; width: 150px;"> <ul style="list-style-type: none"> Replace the DC Pump </div> </div> </div> <div style="display: flex; align-items: center; justify-content: center; margin-top: 20px;"> <div style="text-align: center;"> <p>YES</p> <p>↓</p> <p style="border: 1px solid black; padding: 5px; width: 150px; text-align: center;">Normal condition</p> </div> </div>	
<p>* diagnostic test : go to page 22</p>	

■ Test 10 Generator Assembly

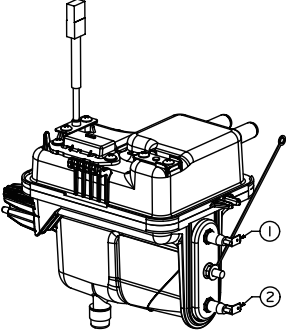
Caution	Before measuring resistance, be sure to turn Power off, and do voltage discharge. (When discharging, contact the metal plug of Power cord with earth line.)
Trouble Symptom	① During Steam cycle, Generator Assembly is not heating. ② During Diagnostic Test, tE4 Error occur.
Measurement Condition	Turn the Dryer's Power Off, then measure resistance.
	<div style="display: flex; align-items: center;"> <div style="border: 1px solid black; padding: 10px; margin-right: 20px;"> <p>Is resistance $14.3 \Omega (\pm 5\%)$ between Heater terminal ① and ② ?</p> </div> <div style="font-size: 2em; margin-right: 10px;"> <p>NO</p> </div> <div style="border: 1px solid black; padding: 10px; margin-right: 20px;"> <p>YES</p> </div> <div style="border: 1px solid black; padding: 10px; margin-right: 20px;"> <p>Normal condition</p> </div> <div style="border: 1px solid black; padding: 10px;"> <ul style="list-style-type: none"> Replace the Generator Assembly If measured resistance value is ∞, replace the Generator Assembly too. </div> </div>

11

CHANGE GAS SETTING (NATURAL GAS, PROPANE GAS)

Warning

Changing orifices and gas valve adjustments improperly can result in an explosion and/or fire. Conversion must be made by a qualified technician.

Initially, Natural Gas mode is set. Propane Gas Orifice is on sale as a Service Part to authorized servicers only.

STEP 1 : VALVE SETTING

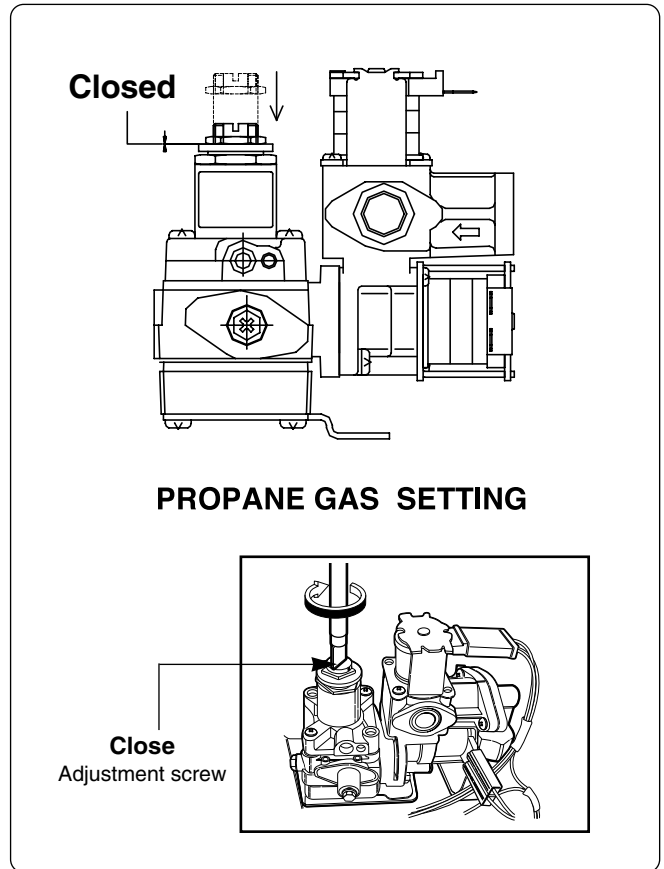
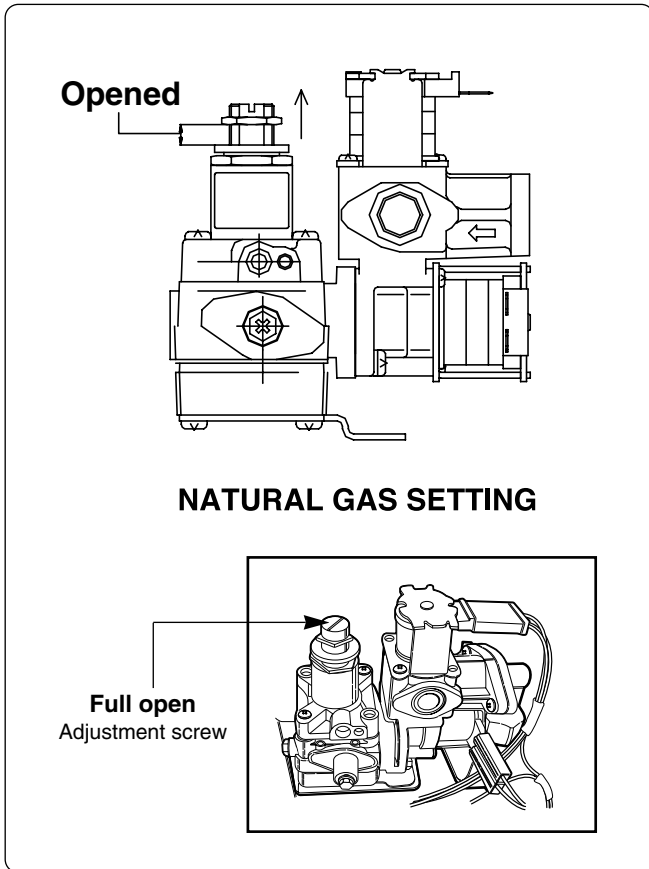

STEP 2 : ORIFICE CHANGE

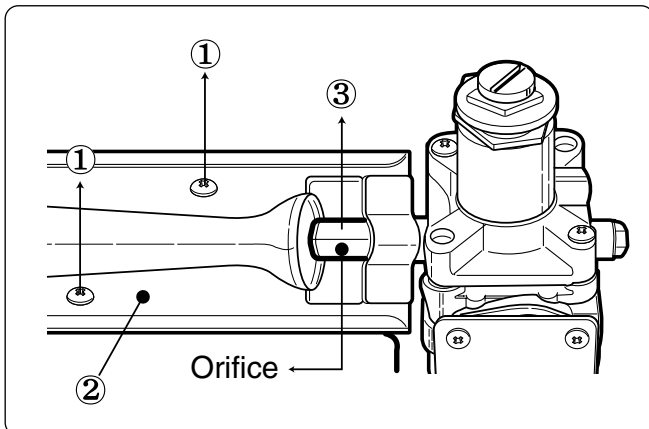

Remove 2 screws.
Disassemble the pipe assembly.
Replace Natural Gas orifice with Propane Gas orifice.

Gas type	Orifice P/No	Marking	Shape
Natural Gas	4948EL4001B	NCU	
Propane Gas	4948EL4002C	PCK	

Kit contents: Orifice (Dia. = 1.470mm, for Propane Gas)
Replace Label
Instruction Sheet

■ GAS VALVE FLOW

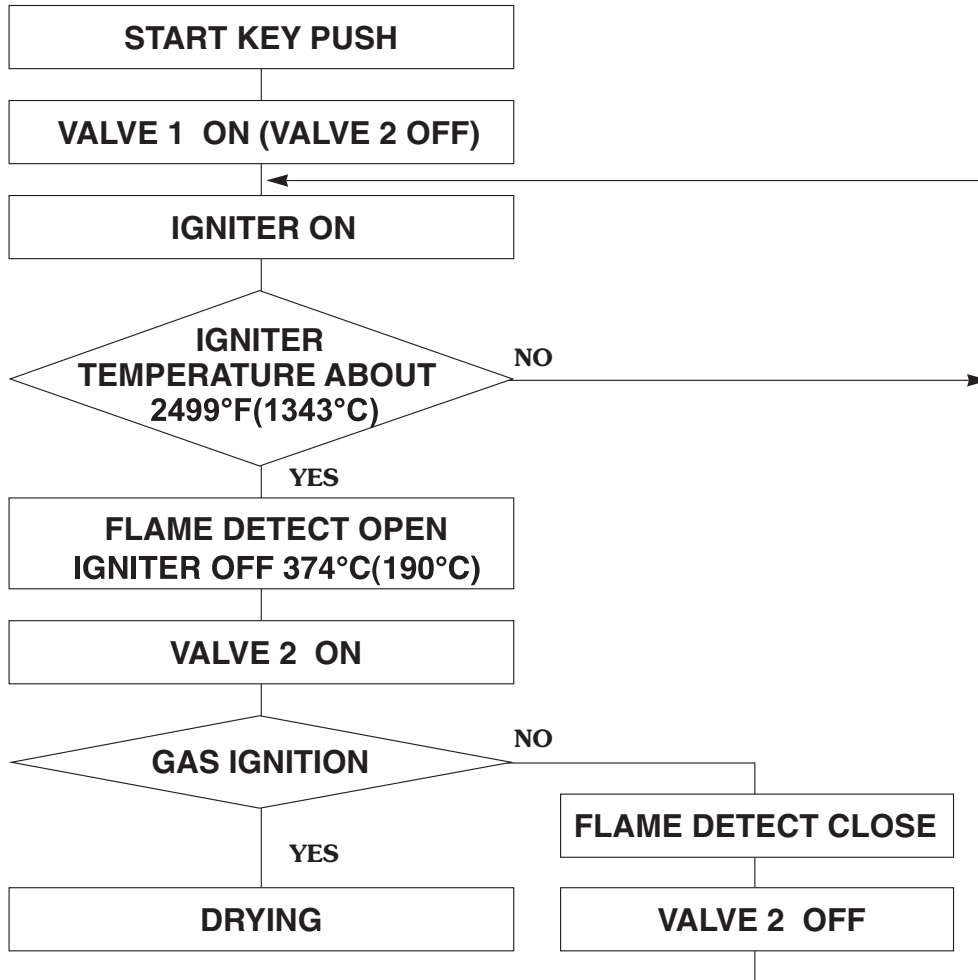

GAS IGNITION

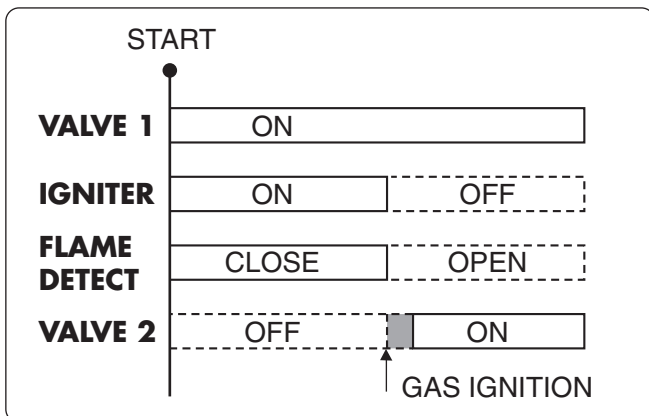

GAS VALVE STRUCTURE

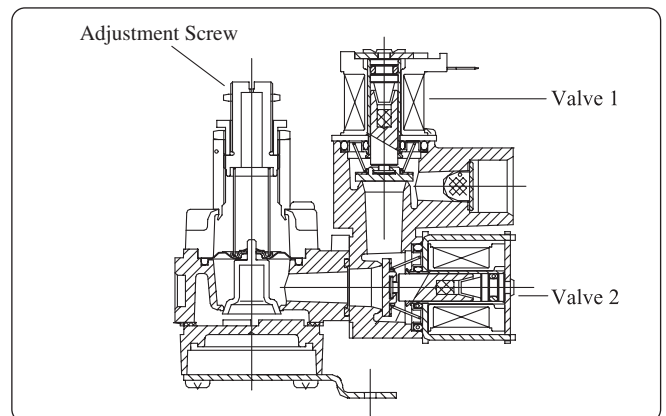

12

DISASSEMBLY INSTRUCTIONS

※ Disassemble and repair the unit only after pulling out power plug from the outlet.

TOP PLATE

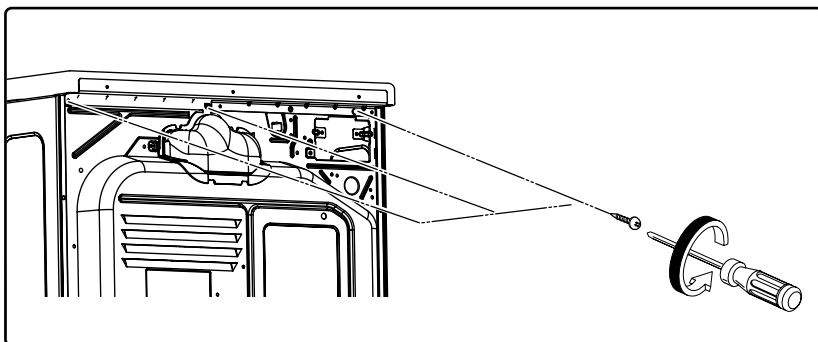

⚠ WARNING !

When you disassemble the top plate, be sure to take gloves and careful plate edge. Failure to do so can cause serious injury.

1. Remove 3 screws on the upper plate.

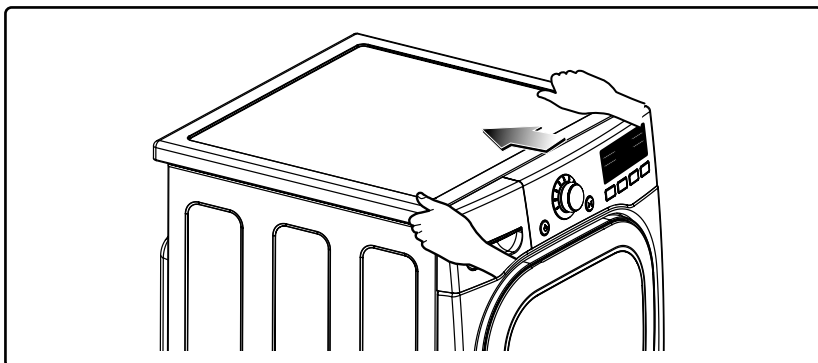

2. Push the top plate backward.

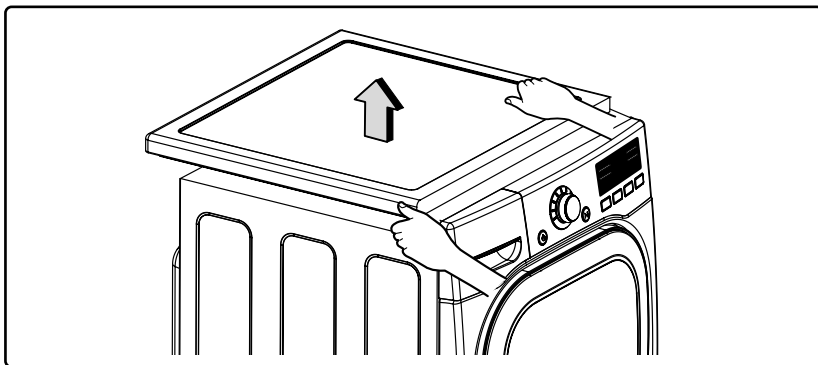

3. Lift the top plate

PANEL DRAWER ASSEMBLY

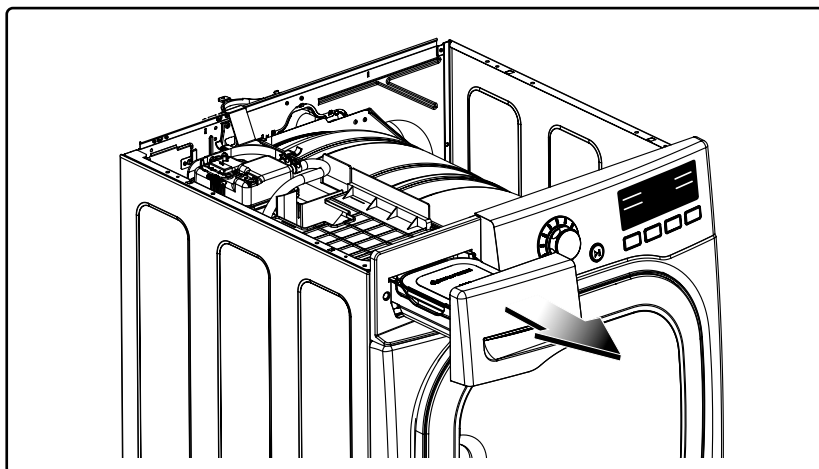

1. Pull out the drawer

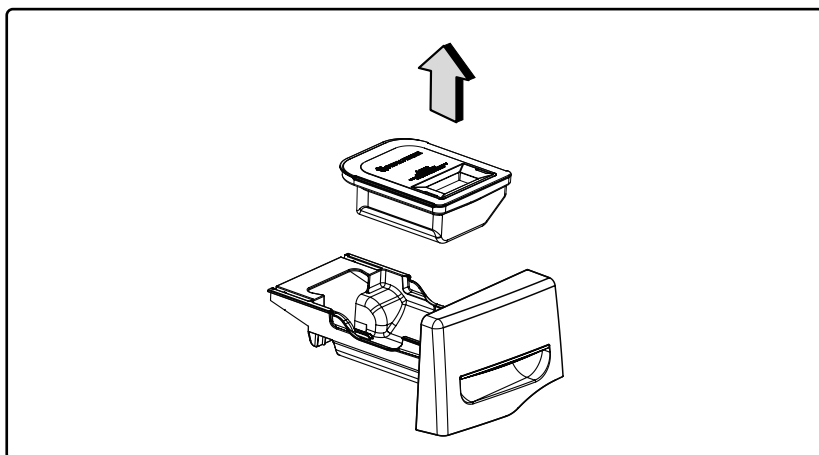

2. Lift out the Steam feeder.

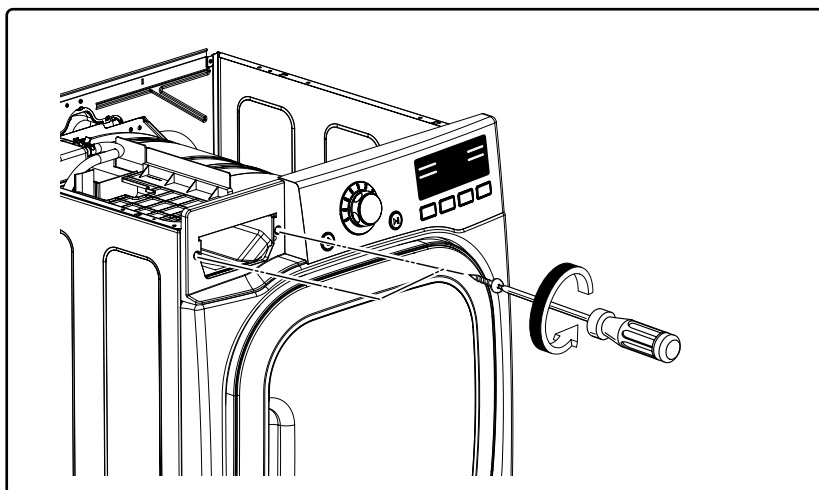

3. Remove 2 screws on the control panel.

CONTROL PANEL ASSEMBLY

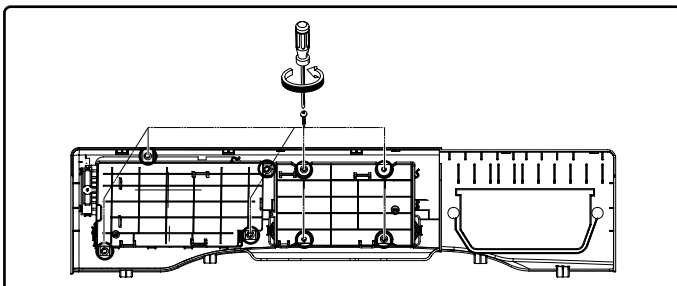
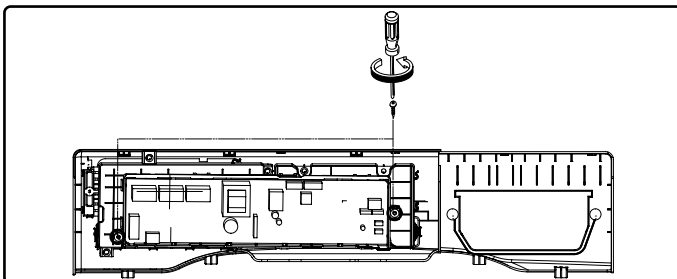
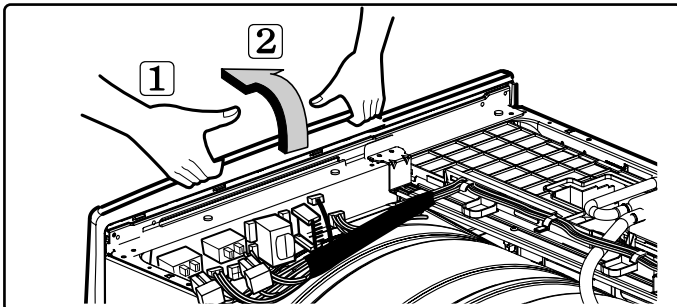
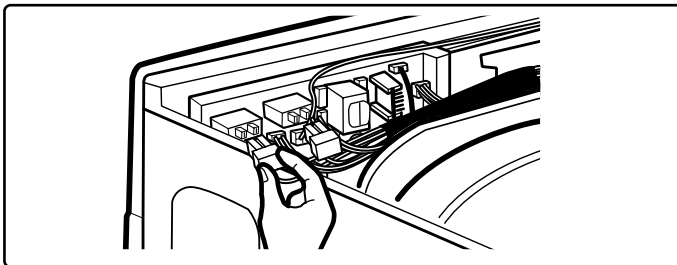
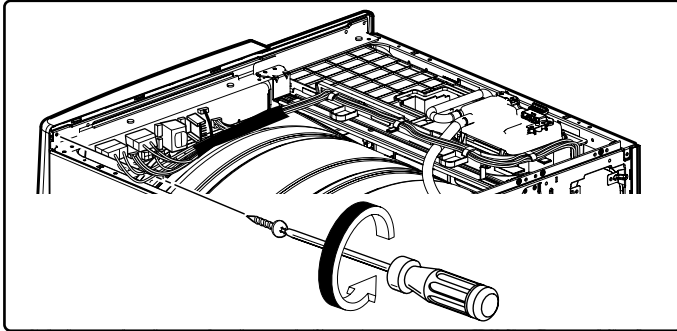

⚠ WARNING !

When you disassemble the control panel, be sure to take gloves and careful panel frame's edge. Failure to do so can cause serious injury.

1. Remove 1 screw on the control panel frame.

2. Disconnect the connectors.

3. Pull the control panel assembly upward and then forward.

4. Remove 2 screws on the PWB(PCB) assembly, main.

5. Disassemble the main PWB

6. Remove 8 screws on the PWB(PCB) assembly, display.

7. Disassemble the display PWB

COVER CABINET

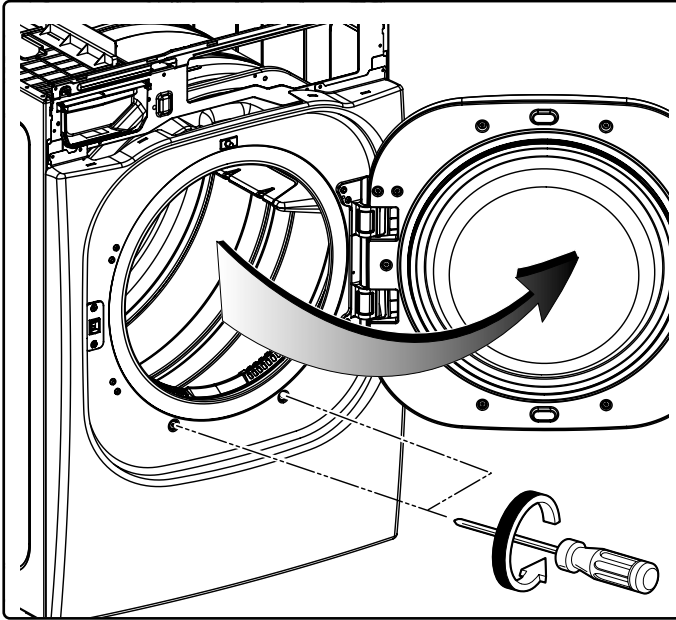

⚠ WARNING !

When you disassemble the door switch connector, be sure to take gloves and careful cabinet edge. Failure to do so can cause serious injury.

1. Disassemble the top plate.
2. Disassemble the control panel assembly.
3. Disassemble the door assembly.
4. Remove 2 screws.
5. Remove 3 screws from the top of cabinet cover.
6. Disconnect the harness of door switch.

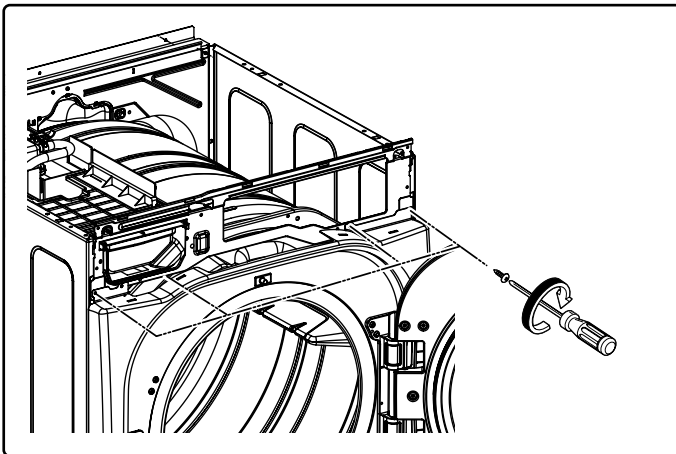

GUIDE ASM

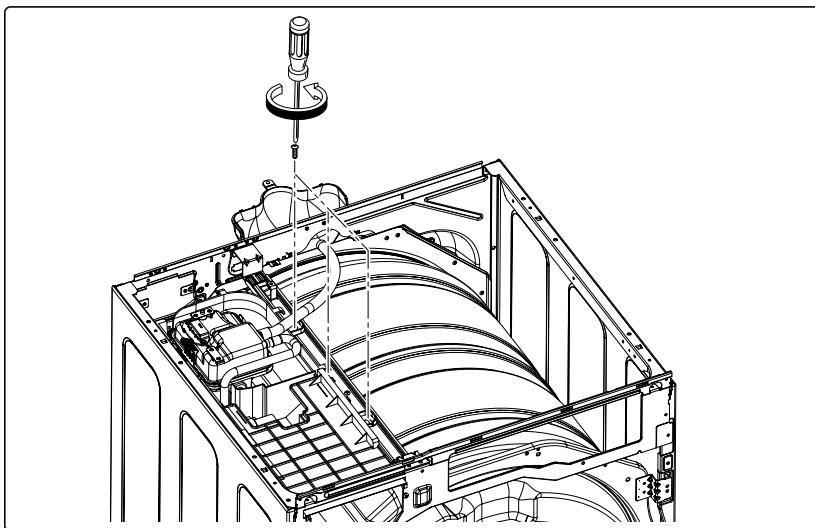

1. Remove 3 screws on the frame body.

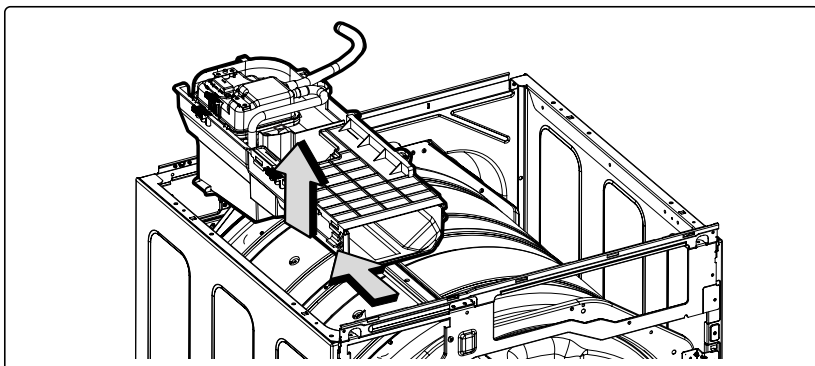

2. Push the Guide ASM to the back side and then lift it.

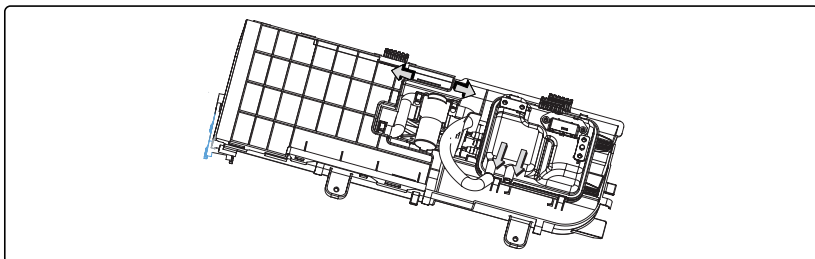

3. Separate 2 hoses from the pump and generator.

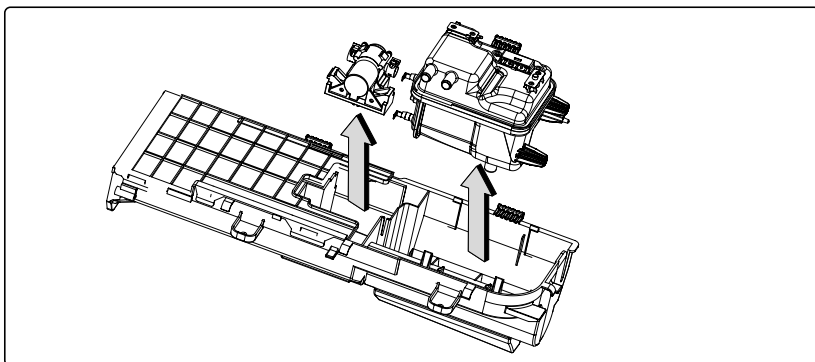

4. Lift a pump and a generator up.

FRAME BODY & PANEL FRAME

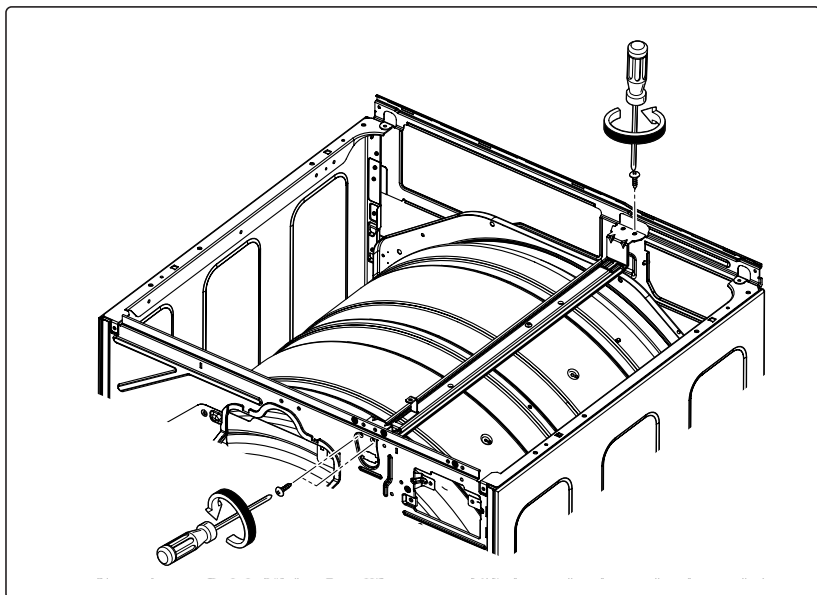

1. Remove 3 screws on the frame body and then disassemble the frame body.

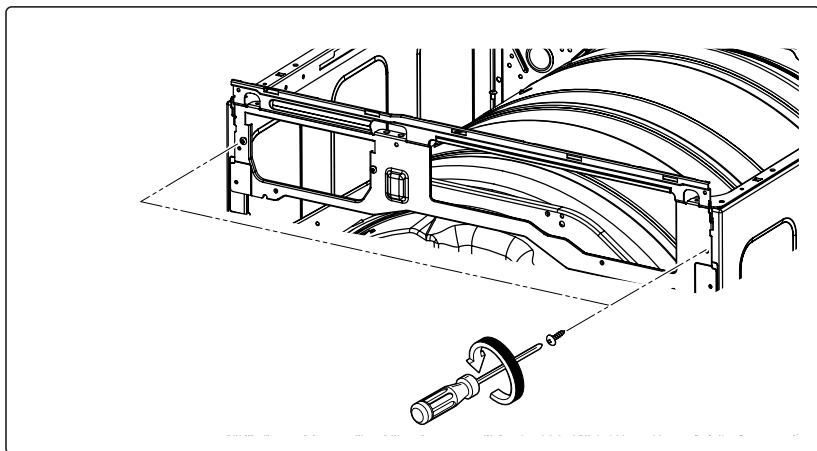

2. Remove 4 screws on the panel frame and then disassemble the panel frame.

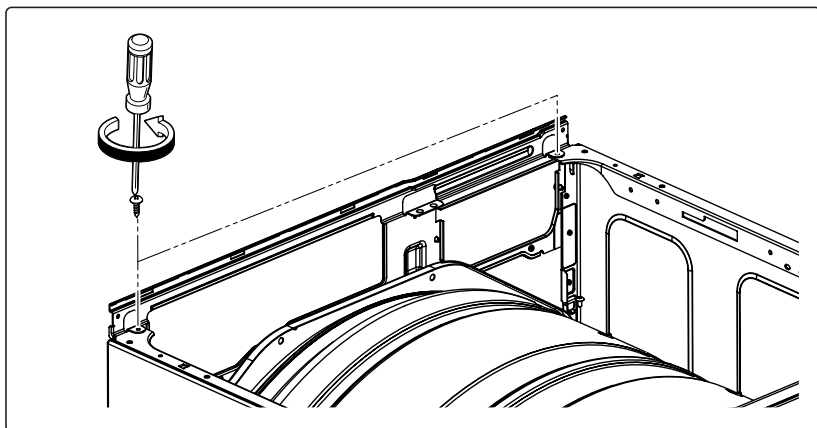

TUB DRUM [FRONT]

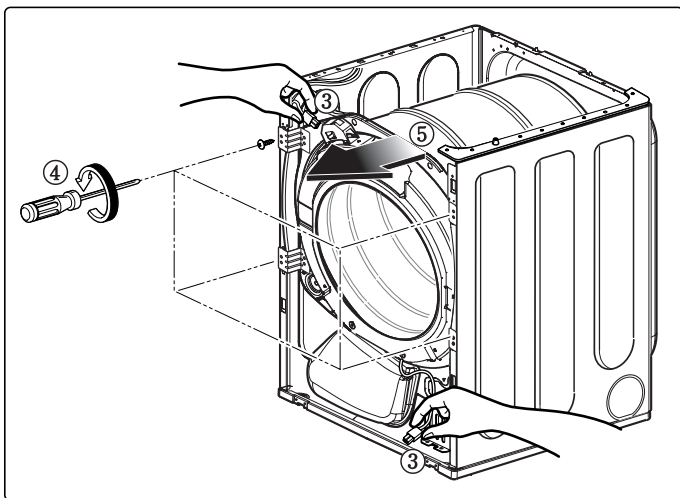

DRUM ASSEMBLY

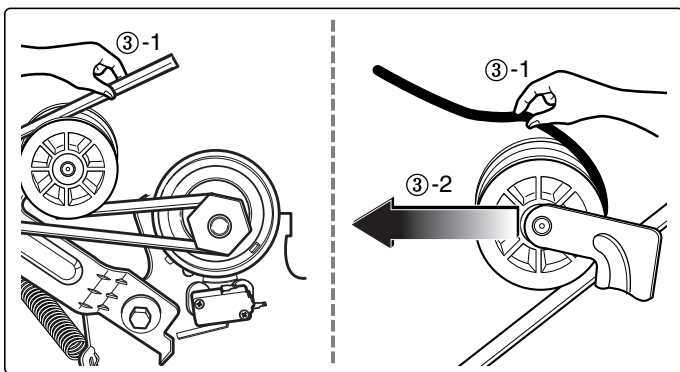

CHANGING THE DRUM LAMP

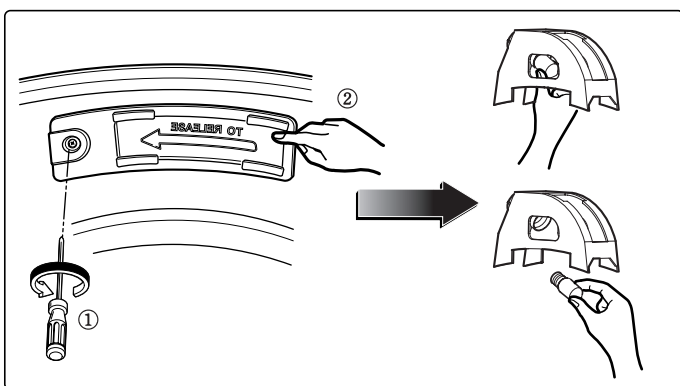

⚠ WARNING !

When you disassemble the lamp connector, be sure to take gloves and careful cabinet edge. Failure to do so can cause serious injury.

1. Disassemble the top plate.
2. Remove Cover Cabinet.
3. Disconnect the door lamp and electrode sensor connector.
4. Remove 4 screws.
5. Disassemble the Tub Drum [Front].

1. Disassemble the top plate.
2. Remove the Cabinet Cover and Tub drum [front].
3. Loosen belt from motor and idler pulleys.
4. Carefully remove the drum.

1. Disassemble the door.
2. Hold the lamp shield in place while removing the screw.
3. Slide the shield up and remove.
4. Remove the bulb and replace with a 15 watt, 120 volt candelabra-base bulb.
5. Replace the lamp shield and screw.

DRYER EXHAUST CHANGE

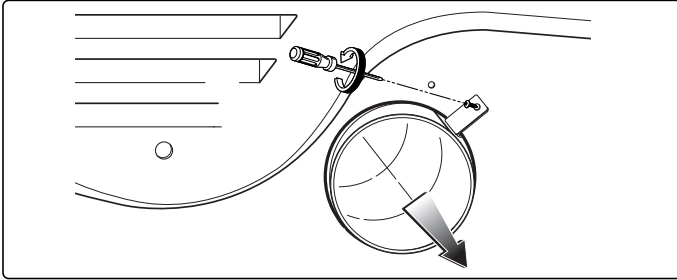

1. Remove a screw and the exhaust duct.

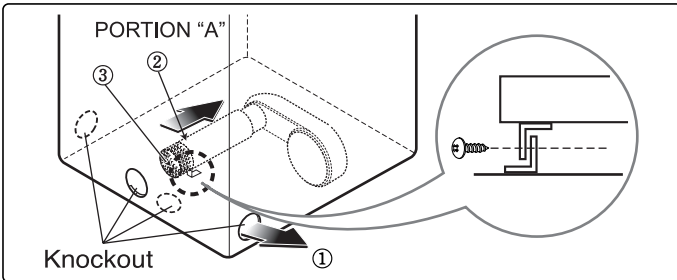

2-1. Detach and remove a knockout at the bottom, left or right side as desired. (Right Side Vent not available on Gas dryer)
①, ②, ③ the order of work.

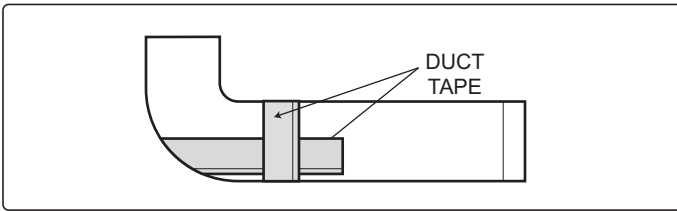

2-2. Reconnect the another duct [11 in (28cm)] to the blower housing, and attach the duct to the base. (Duct is a SVC part)

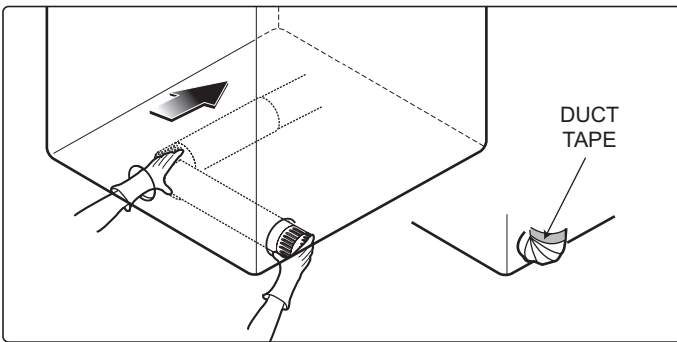

3-1. Pre-assemble 4" elbow with 4" duct.
Wrap duct tape around joint.

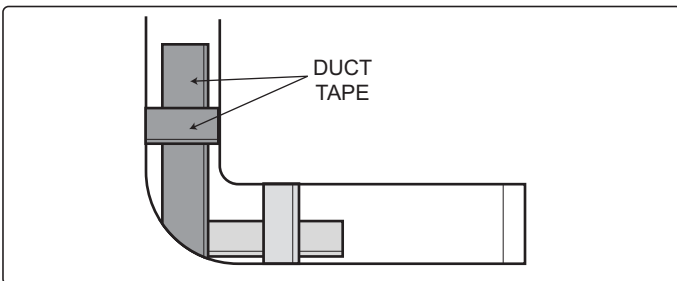

3-2. Insert the elbow duct assembly through the side opening and connect the elbow to the internal duct.

FILTER ASSEMBLY

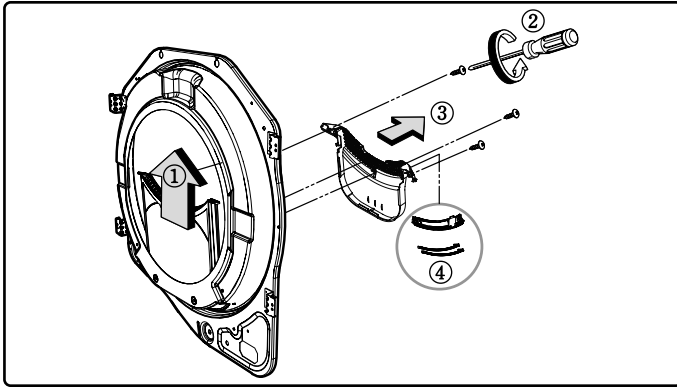

1. Remove the filter.
2. Remove 3 screws.
3. Remove the Cover Grid.
4. Disconnect the electrode sensor.

BLOWER HOUSING

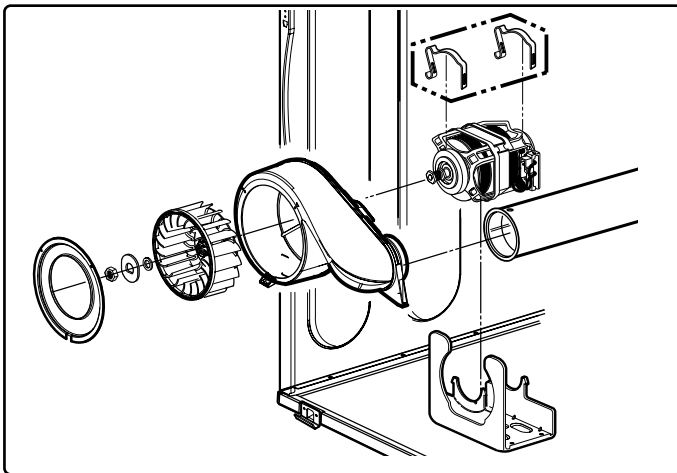

1. Disassemble the top plate.
2. Remove the Cabinet Cover and Tub Drum [Front].
3. Remove the Drum assembly.
4. Remove 2 screws and cover (Air guide).
5. Remove the bolt and washer.
6. Remove the fan.
7. Disconnect the motor clamp and motor.

BACK COVER

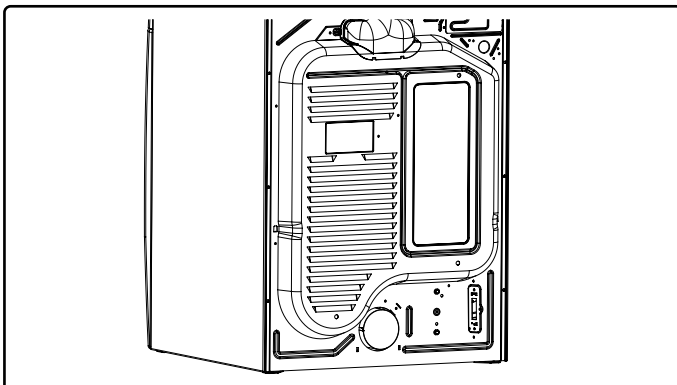

1. Disassemble the top plate.
2. Remove the Cabinet Cover and Tub Drum [Front].
3. Remove the Drum assembly.
4. Remove 7 screws.
5. Remove the Back Cover.

AIR DUCT

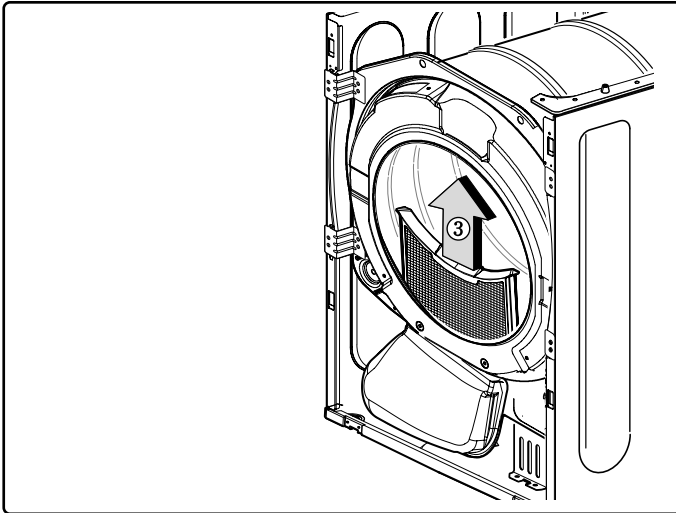

1. Disassemble the top plate.
2. Remove the Cover Cabinet.
3. Remove the filter.

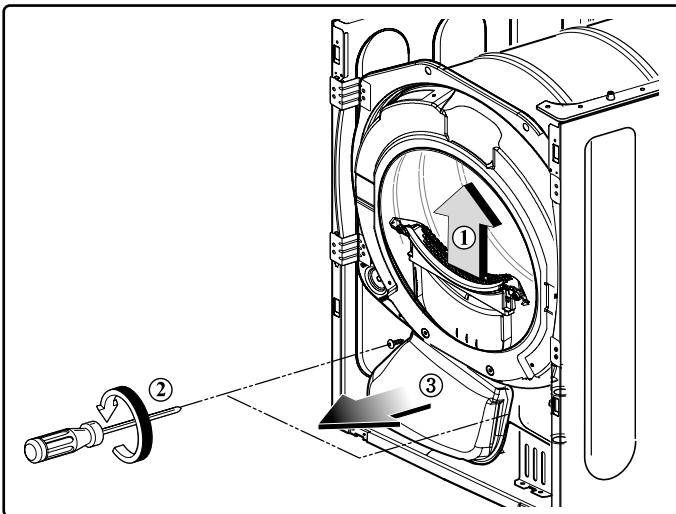

1. Remove the Cover guide.
2. Remove 2 screws.
3. Remove the air duct.

ROLLERS

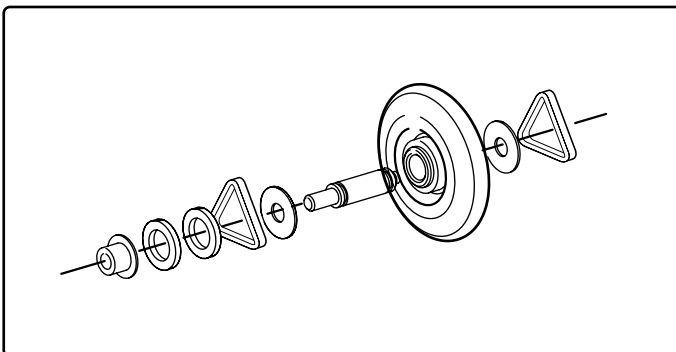

1. Disassemble the top plate.
2. Remove the Cover Cabinet and Tub Drum [Front].
3. Remove the Drum assembly and Tub Drum [Rear].
4. Disconnect the Air duct from the Tub Drum [Front].
5. Remove the roller from the Tub Drum [Front] and Tub Drum [Rear].

13

EXPLODED VIEW

13-1. Control Panel & Plate Assembly

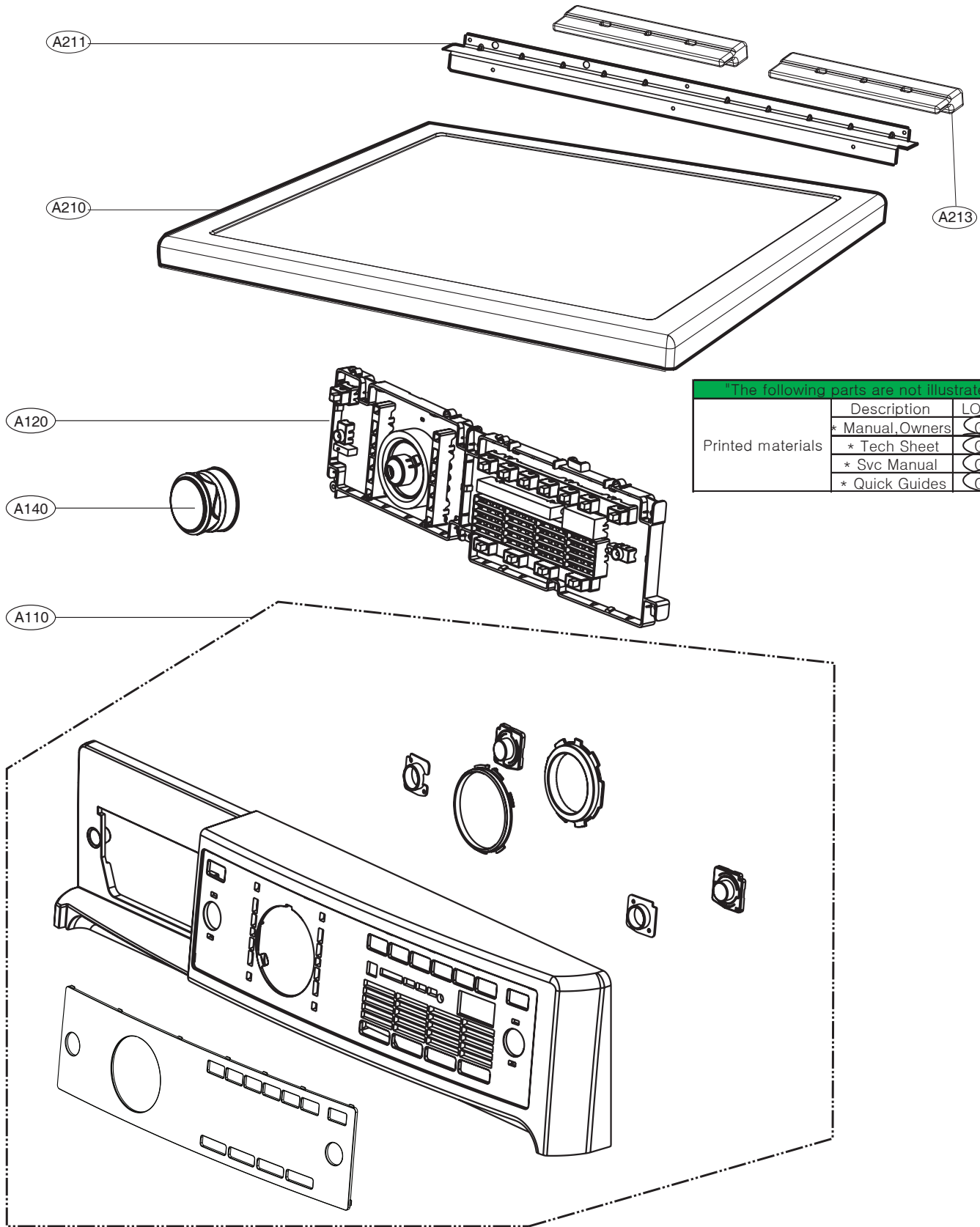

"The following parts are not illustrated"

	Description	LOC. NO.
Printed materials	* Manual, Owners	G001
	* Tech Sheet	G003
	* Svc Manual	G004
	* Quick Guides	G006

13-2. Panel Drawer Assembly & Guide Assembly

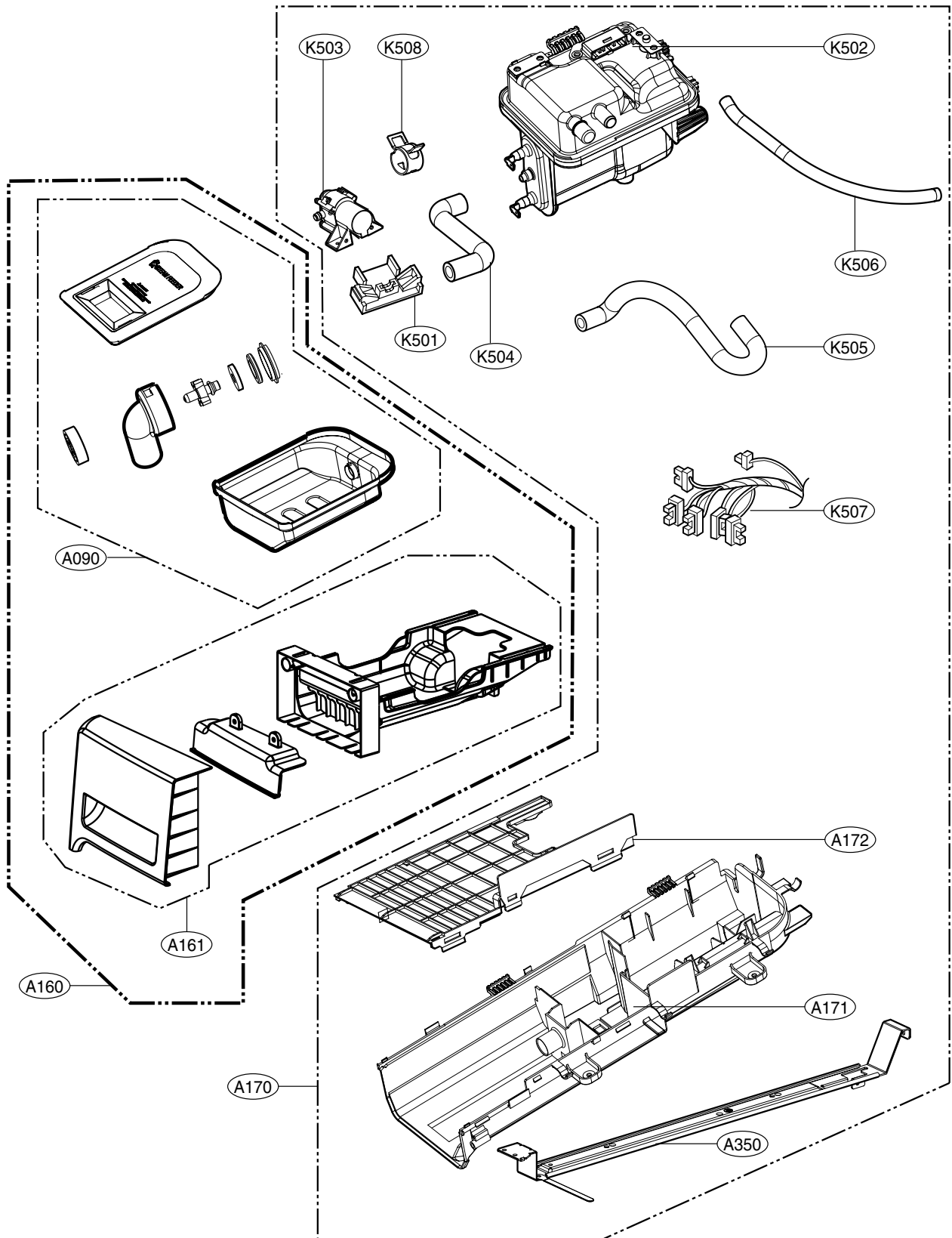

13-3-2. Cabinet & Door Assembly: Gas type

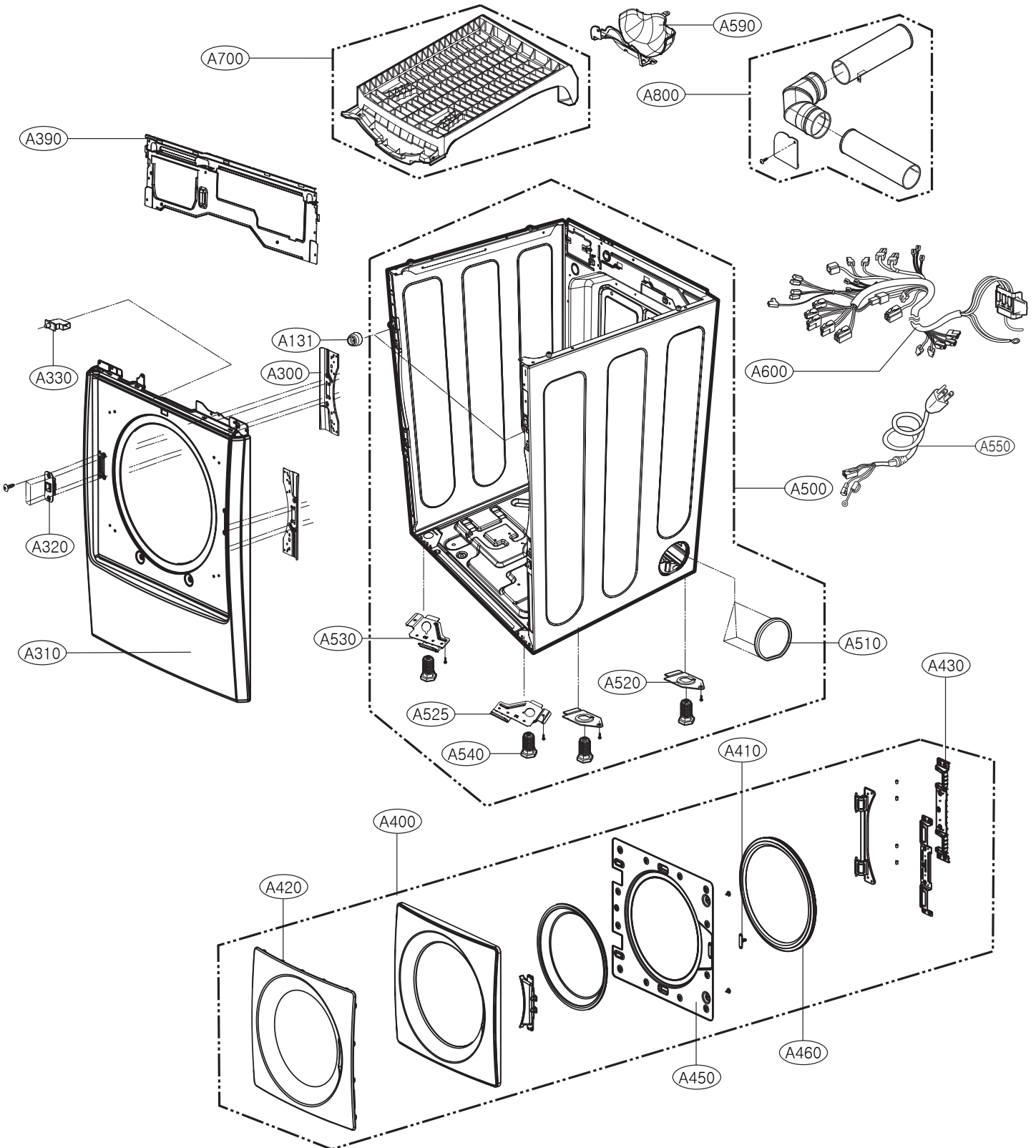

13-4-2. Drum & Motor Assembly: Gas type

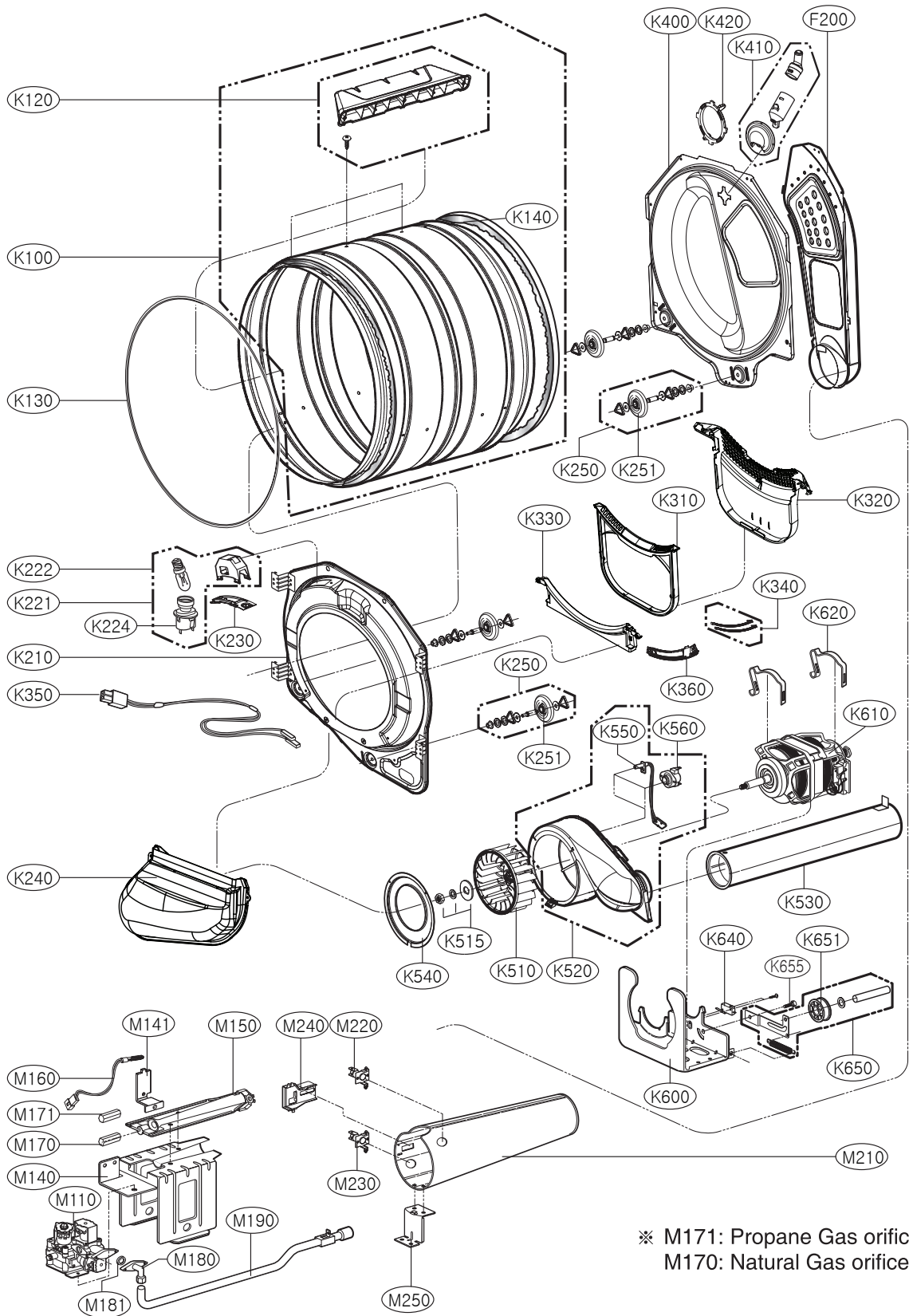

※ M171: Propane Gas orifice
M170: Natural Gas orifice