

This Owner's Manual is provided and hosted by [Appliance Factory Parts](#).



LG 98852 Owner's Manual

[Shop genuine replacement parts for LG 98852](#)



[Find Your LG Dryer Parts - Select From 451 Models](#)

----- Manual continues below -----



ELECTRIC & GAS DRYER SERVICE MANUAL

CAUTION

READ THIS MANUAL CAREFULLY TO DIAGNOSE
TROUBLES CORRECTLY BEFORE OFFERING SERVICE.

MODEL : 796.88842800 / 796.98842800
796.88852800 / 796.98852800



MAR. 2008 PRINTED IN KOREA

P/No.:3828EL3001D

IMPORTANT SAFETY NOTICE

The information in this service guide is intended for use by individuals possessing adequate backgrounds of electrical, electronic, and mechanical experience. Any attempt to repair a major appliance may result in personal injury and property damage. The manufacturer or seller cannot be responsible for the interpretation of this information, nor can it assume any liability in connection with its use.

WARNING !

To avoid personal injury, disconnect power before servicing this product. If electrical power is required for diagnosis or test purposes, disconnect the power immediately after performing the necessary checks.

RECONNECT ALL GROUNDING DEVICES

If grounding wires, screws, straps, clips, nuts, or washers used to complete a path to ground are removed for service, they must be returned to their original position and properly fastened.

WHAT TO DO IF YOU SMELL GAS:

- *Do not try to light a match, or cigarette, or turn on any gas or electrical appliance.*
- *Do not touch any electrical switches. Do not use any phone in your building.*
- *Clear the room, building or area of all occupants.*
- *Immediately call your gas supplier from a neighbor's phone. Follow the gas supplier's instructions carefully.*
- *If you cannot reach your gas supplier, call the fire department.*

IMPORTANT

Electrostatic Discharge (ESD)
Sensitive Electronics

ESD problems are present everywhere. ESD may damage or weaken the electronic control assembly. The new control assembly may appear to work well after repair is finished, but failure may occur at a later date due to ESD stress.

- Use an anti-static wrist strap. Connect wrist strap to green ground connection point or unpainted metal in the appliance.

- OR -

Touch your finger repeatedly to a green ground connection point or unpainted metal in the appliance.

- Before removing the part from its package, touch the anti-static bag to a green ground connection point or unpainted metal in the appliance.
- Avoid touching electronic parts or terminal contacts; handle electronic control assembly by edges only.
- When repackaging failed electronic control assembly in anti-static bag, observe above instructions.

CONTENTS

1. SPECIFICATIONS	4
2. FEATURES AND BENEFITS	5
3. INSTALLATION INSTRUCTIONS	6
4. COLUMBUS DRYER CYCLE PROCESS	9
5. COMPONENT TESTING INFORMATION	10
6. MOTOR DIAGRAM AND SCHEMATIC.....	13
7. CONTROL LAY - OUT	14
8. WIRING DIAGRAM	15
9. DIAGNOSTIC TEST	16
9-1. TEST 1 120VAC ELECTRICAL SUPPLY.....	17
9-2. TEST 2 THERMISTOR TEST --- MEASURE WITH POWER OFF	18
9-3. TEST 3 MOTOR TEST	19
9-4. TEST 4 MOISTURE SENSOR	20
9-5. TEST 5 DOOR SWITCH TEST	21
9-6. TEST 6 HEATER SWITCH TEST - ELECTRIC TYPE.....	22
9-7. TEST 7 GAS VALVE TEST - GAS TYPE.....	23
10. CHANGE GAS SETTING (NATURAL GAS, PROPANE GAS)	24
11. DISASSEMBLY INSTRUCTIONS	26
12. EXPLODED VIEW	32
12-1. CONTROL PANEL & PLATE ASSEMBLY	32
12-2. CABINET & DOOR ASSEMBLY.....	33
12-3-1. DRUM & MOTOR ASSEMBLY : ELECTRIC TYPE	34
12-3-2. DRUM & MOTOR ASSEMBLY : GAS TYPE	35
13. REPLACEMENT PARTS LIST	36

1

SPECIFICATIONS

ITEM		88842 / 88852 / 98842 / 98852	REMARK
Material & Finish	Color	White	
	Top Plate	Spray	
	Door Trim	Silver	
POWER SUPPLY		120V / 240V 60Hz (26A)	
ELECTRICITY CONSUMPTION	MOTOR	250W (4.5A)	AC 120V
	HEATER	5400W (22.5A)	AC 240V (ELECTRIC TYPE)
	LAMP	15W (125mA)	AC 120V
	GAS VALVE	13W (110mA) X 2	AC 120V (GAS TYPE)
CONTROL TYPE		Electronic	
DRUM CAPACITY		7.3 cu.ft.	
Weight (lbs): Net/Gross		126 / 144	
No. of Programs		9	
No. of Dry Option		5	
No. of Temperature Controls		5	
No. of Dry Levels		5	
Audible End of Cycle Beeper		High / Low / Off	
Sensor	Moisture	Equipped	Electro sensor
	Temperature	Equipped	Thermistor
Reversible Door		Adopted	
Drum		Stainless Steel	
Dryer Rack		Equipped	
Child lock		Equipped	
Interior Light		Equipped	
Product (WXHxD)		27" x 42 3/4" x 28 1/3"	
Packing (WXHxD)		29 1/2" x 44 3/4" x 30 3/4"	

2

FEATURES AND BENEFITS

■ 88842/88852/98842/98852



3

INSTALLATION INSTRUCTIONS

3-1. POWER CORD

1) 4-wire connection

IMPORTANT: A 4-wire connection is required for mobile homes and where local codes do not permit the use of 3 wire connections.

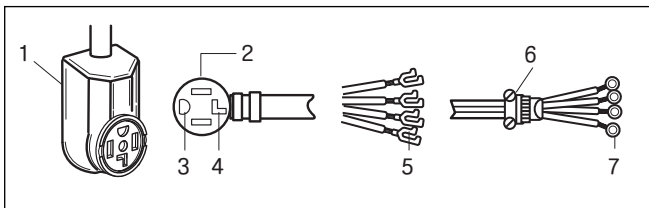

1. 4-wire receptacle (NEMA type 14-30R)
2. 4-prong plug
3. Ground prong
4. Neutral prong
5. Spade terminals with upturned ends
6. 3/4 in. (1.9 cm) UL approved strain relief
7. Ring terminals

1. Remove center terminal block screw.
2. Remove appliance ground wire (green) from external ground connector screw. Fasten it under center, silver colored terminal block screw.

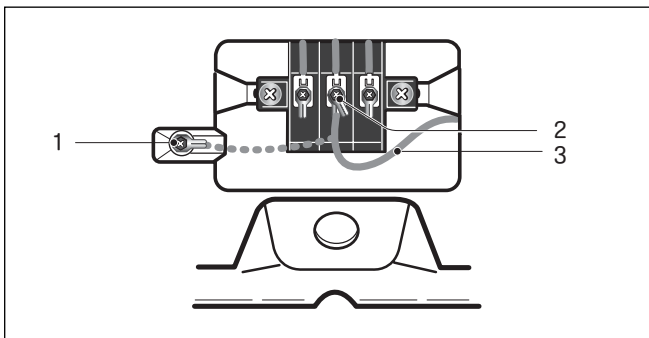

1. External ground connector - Dotted line shows position of NEUTRAL ground wire before being moved to center terminal block screw
2. Center silver-colored terminal block screw
3. Green wire of harness

3. Connect ground wire (green or bare) of power supply cable to external ground conductor screw. Tighten screw.
4. Connect neutral wire (white or center wire) of power supply cord to the center, silver colored terminal screw of the terminal block.

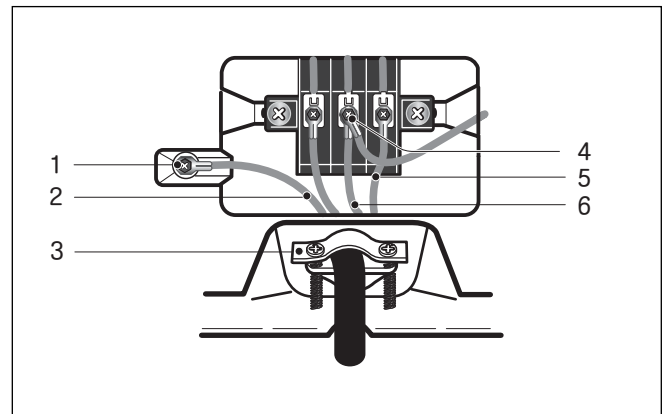

1. External ground connector
 2. Green or bare copper wire of power supply cord
 3. 3/4 in. (1.9 cm) UL-listed strain relief
 4. Center silver-colored terminal block screw
 5. Neutral grounding wire (green)
 6. Neutral wire (white)
5. Connect the other wires to outer terminal block screws. Tighten screws.
 6. Tighten strain relief screws.
 7. Insert tab of terminal block cover into slot of dryer rear panel. Secure cover with hold-down screw.

2) 3-wire connection

Use where local codes permit connecting cabinet-ground conductor to neutral wire.

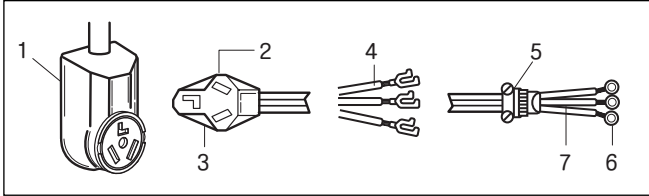

1. 3-wire receptacle (NEMA type 10-30R)
2. 3-wire plug
3. Neutral prong
4. Spade terminals with up turned ends
5. 3/4 in. (1.9 cm) UL approved strain relief
6. Ring terminals
7. Neutral (white or center wire)

1. Loosen or remove center terminal block screw.
2. Connect neutral wire (white or center wire) of power supply cord to the center, silver colored terminal screw of the terminal block. Tighten screw.

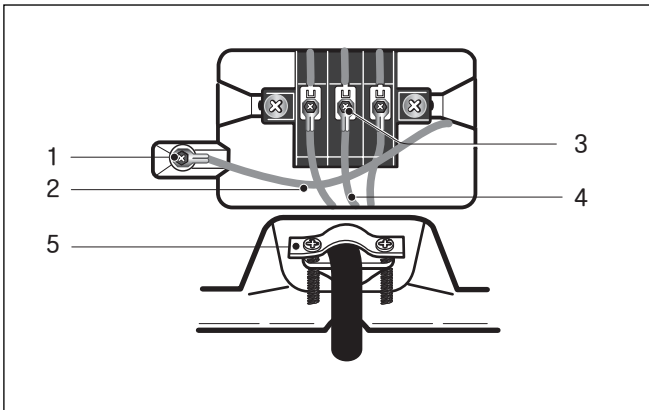

1. External ground connector
2. Neutral grounding wire (green)
3. Center silver-colored terminal block screw
4. Neutral wire (white or center wire)
5. 3/4 in. (1.9 cm) UL-listed strain relief

3. Connect the other wires to outer terminal block screws. Tighten screws.
4. Tighten strain relief screws.
5. Insert tab of terminal block cover into slot of dryer rear panel. Secure cover with hold-down screw.

3) Optional 3-wire connection

Use where local codes permit connecting cabinet-ground conductor to neutral wire.

1. Remove center terminal block screw.
2. Remove appliance ground wire (green) from external ground connector screw. Connect appliance ground wire and the neutral wire (white or center wire) of power supply cord/cable under center, silver colored terminal block screw. Tighten screw.
3. Connect the other wires to outer terminal block screws. Tighten screws.

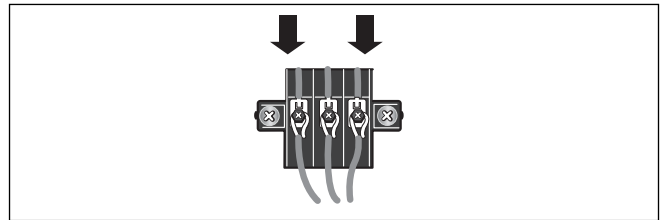

4. Tighten strain relief screws.
5. Insert tab of terminal block cover into slot of dryer rear panel. Secure cover with hold-down screw.
6. Connect a separate copper ground wire from the external ground connector screw to an adequate ground.

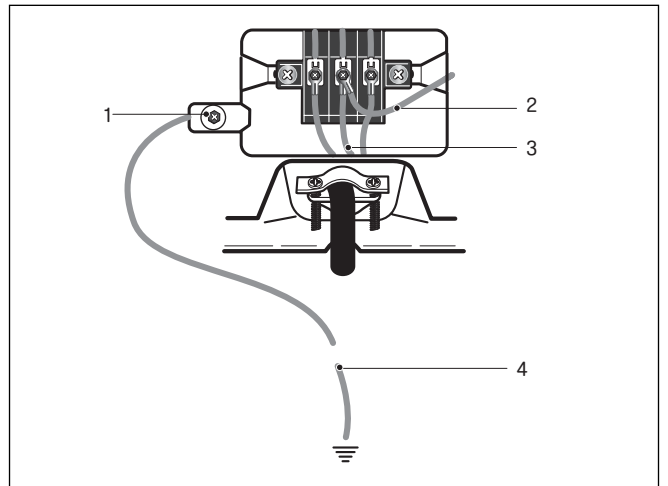

1. External ground connector
2. Neutral grounding wire (green)
3. Neutral wire (white or center wire)
4. Grounding path determined by a qualified electrician

3-2. Connect Gas Supply Pipe (Gas Dryer ONLY)

For further assistance, refer to section on **Gas Requirements**.

1. Make certain your dryer is equipped for use with the type of gas in your laundry room. Dryer is equipped at the factory for Natural Gas with a 3/8" N.P.T. gas connection.
2. Remove the shipping cap from the gas connection at the rear of the dryer. Make sure you do not damage the pipe thread when removing the cap.
3. Connect to gas supply pipe using a new flexible stainless steel connector.
4. Tighten all connections securely. Turn on gas and check all pipe connections (internal & external) for gas leaks with a non-corrosive leak detection fluid.
5. For L.P. (Liquefied Petroleum) gas connection, refer to section on Gas Requirements.

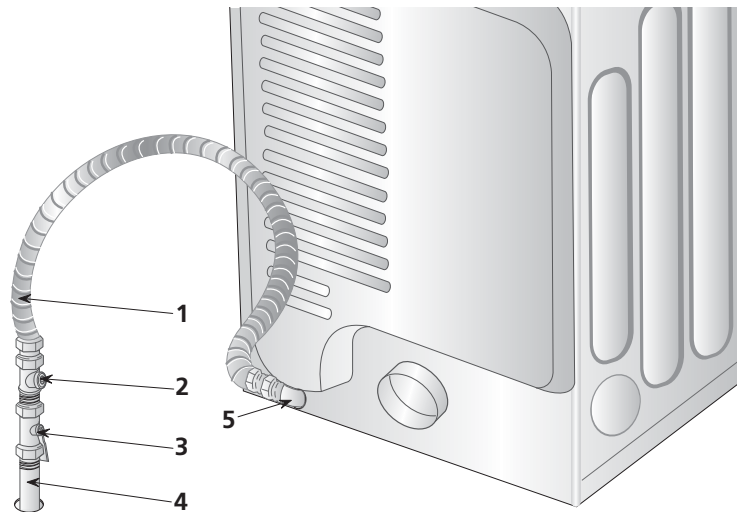

- 1 New Stainless Steel Flexible Connector - Use only if allowed by local codes (Use Design A.G.A. Certified Connector)
- 2 1/8" N.P.T. Pipe Plug (for checking inlet gas pressure)
- 3 Equipment Shut-Off Valve-Installed within 6' (1.8 m) of dryer

- 4 Black Iron Pipe
Shorter than 20' (6.1 m) - Use 3/8" pipe
Longer than 20' (6.1 m) - Use 1/2" pipe
- 5 3/8" N.P.T. Gas Connection

4

COLUMBUS DRYER CYCLE PROCESS

Cycle		Default			Conditions of operation and termination				
		Temp-erature	Dry Level	Display time	Drying		Cooling		Wrinkle care
					Electro-sensor	Temp-control	Default time	Temp-Control**	Time
Sensor Dry *	Sanitary	High	(Very)	1:10min	Saturation	68 ±5°C	(5min)	(47 ±5°C)	3Hr
	Heavy Duty	High	(Normal)	54min	Saturation	68 ±5°C	(5min)	(47 ±5°C)	
	Cotton/ Towel	Medium High	(Normal)	55min	Saturation	66 ±5°C	(5min)	(47 ±5°C)	
	Normal	Medium	(Normal)	41min	Saturation	60 ±5°C	(5min)	(47 ±5°C)	
	Casual	Low	(Normal)	36min	Saturation	55 ±5°C	(5min)	(47 ±5°C)	
	Delicate	Low	(Normal)	32min	Saturation	55 ±5°C	(5min)	(38 ±5°C)	
Manual Dry **	Speed Dry	(High)	-	25min	Saturation	(70 ±5°C)	(5min)	(47 ±5°C)	3Hr
	Freshen Up	(Midium High)	-	20min	Saturation	(66 ±5°C)	(5min)	(47 ±5°C)	
	Air Dry	-	-	30min	Saturation	No heater	N/A	N/A	
Load		Motor							Off Time: 6min
					Heater				
								Temperature Control for each cycle	

* Sensor dry : “Dry Level” is set by users.
 ** Manual dry : “Temperature control” is set by users.
 Default settings can be adjusted by users.

5

COMPONENT TESTING INFORMATION

CAUTION When checking the Component, be sure to turn the power off, and do voltage discharge sufficiently.

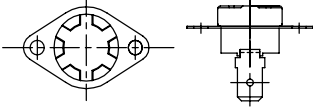
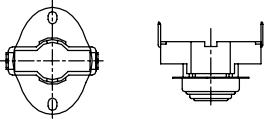
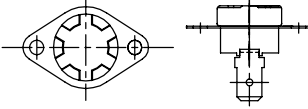
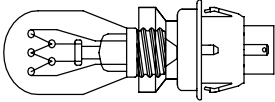
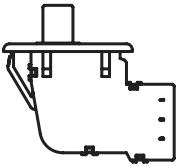
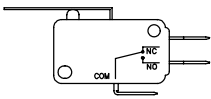
Component	Test Procedure	Check result	Remark
1. Thermal cut off  • Check Top Marking : N130	Measure resistance of terminal to terminal ① Open at $284 \pm 12^{\circ}\text{F}$ ($140 \pm 7^{\circ}\text{C}$) ② Auto reset -31°F (-35°C) Same shape as Outlet Thermostat.	If thermal fuse is open must be replaced ① Resistance value $\approx \infty$ ② Continuity ($250^{\circ}\text{F} \downarrow$) $< 1\Omega$	• Heater case-Safety • Electric type
2. Hi limit Thermostat (Auto reset) 	Measure resistance of terminal to terminal ① Open at $257 \pm 9^{\circ}\text{F}$ ($125 \pm 5^{\circ}\text{C}$) ② Close at $221 \pm 9^{\circ}\text{F}$ ($105 \pm 5^{\circ}\text{C}$)	① Resistance value $\approx \infty$ ② Resistance value $< 5\Omega$	• Heater case - Hi limit • Electric type
3. Outlet Thermostat (Auto reset)  • Check Top Marking : N85	Measure resistance of terminal to terminal ① Open at $185 \pm 9^{\circ}\text{F}$ ($85 \pm 5^{\circ}\text{C}$) ② Close at $149 \pm 9^{\circ}\text{F}$ ($65 \pm 5^{\circ}\text{C}$) Same shape as Thermal cut off.	① Resistance value $\approx \infty$ ② Resistance value $< 5\Omega$	• Blow housing - Safety • Electric type
4. Lamp holder 	Measure resistance of terminal to terminal	Resistance value : $80\Omega \sim 100\Omega$	
5. Door switch 	Measure resistance of the following terminal 1) Door switch knob : open ① Terminal : "COM" - "NC" (1-3) ② Terminal : "COM" - "NO" (1-2) 2) Door switch push : push ① Terminal : "COM" - "NC" (1-3) ② Terminal : "COM" - "NO" (1-2)	① Resistance value $< 1\Omega$ ② Resistance value $\approx \infty$ ① Resistance value $\approx \infty$ ② Resistance value $< 1\Omega$	The state that Knob is pressed is opposite to Open condition.
6. Idler switch 	Measure resistance of the following terminal : "COM - NC"	1. lever open ① Resistance value $< 1\Omega$ 2. Lever push (close) ② Resistance value $\approx \infty$	

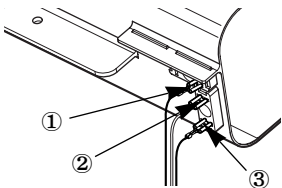
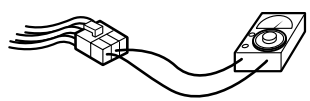
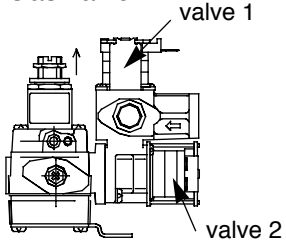
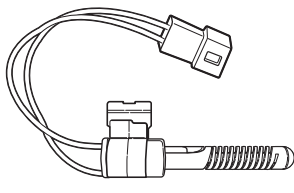
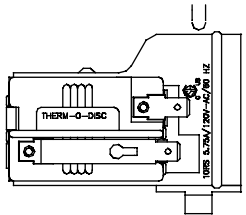
Component	Test Procedure	Check result	Remark
7. Heater 	Measure resistance of the following terminal ① Terminal : 1 (COM) - 2 ② Terminal : 1 (COM) - 3 ③ Terminal : 2 - 3	① Resistance value : 10Ω ② Resistance value : 10Ω ③ Resistance value : 20Ω	<ul style="list-style-type: none"> • Electric type
8. Thermistor 	Measure resistance of terminal to terminal Temperature condition : 58°F ~ (10~40°C) 58°F ~ 104F (10~40°C)	Resistance value : 10Ω	<ul style="list-style-type: none"> • Heater case - Hi limit • Electric type
9. Motor			<ul style="list-style-type: none"> • See Page 13
10. Gas valve 	Measure resistance of the following terminal ① Valve 1 terminal ② Valve 2 terminal	① Resistance value : > 1.5kg ~ ② Resistance value : > 1.5~2.5kg	<ul style="list-style-type: none"> • Gas type
11. Igniter 	Measure resistance of terminal to terminal	Resistance value : 100~800Ω	<ul style="list-style-type: none"> • Gas type
12. Frame Detect 	Measure resistance of terminal to terminal ① Open at 370°F ((Maximum) ② Close at 320°F	① Resistance value ≒ ∞ ② Resistance value < 1Ω	<ul style="list-style-type: none"> • Gas type

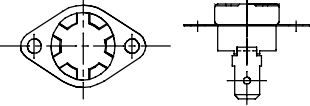
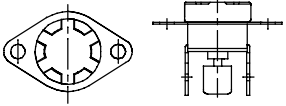
Component	Test Procedure	Check result	Remark
<p>13. Hi-limit Thermostat (Auto reset)</p>  <p>• Check Top Marking : N95</p>	<p>Measure resistance of terminal to terminal</p> <p>① Open at $203 \pm 7^{\circ}\text{F}$ ($95 \pm 5^{\circ}\text{C}$) ② Close at $158 \pm 9^{\circ}\text{F}$ ($70 \pm 5^{\circ}\text{C}$)</p>	<p>① Resistance value $\neq \infty$ ② Continuity $< 1\Omega$</p>	<ul style="list-style-type: none"> • Gas type • Gas funnel- Hi-limit
<p>13. Thermal Cut off (Manual reset)</p>  <p>• Check Top Marking : N110</p>	<p>Measure resistance of terminal to terminal</p> <p>① Open at $230 \pm 12^{\circ}\text{F}$ ($110 \pm 7^{\circ}\text{C}$) ② Manual reset</p>	<p>If thermal fuse is open must be replaced</p> <p>① Resistance value $\neq \infty$ ② Continuity $< 1\Omega$</p>	<ul style="list-style-type: none"> • Gas type • Gas funnel- Safety

6

MOTOR DIAGRAM AND SCHEMATIC

NOTE When checking Component, be sure to turn Power off, then do voltage discharge sufficiently.

■ Contact On / Off by Centrifugal Switch

Terminal No		①	②	③	④	⑤	⑥	Remark
Mode	Resistance							
Motor STOP	2 ~ 3Ω				●	●		Motor
	≒ ∞	●	●					Heater (Electric Models)
	≒ ∞			●			●	Gas Valve (Gas Models)
Motor RUN	3 ~ 5Ω				●	●		Motor
	< 1Ω	●	●					Heater (Electric Models)
	< 1Ω			●			●	Gas Valve (Gas Models)

..... Open
 ——— Close

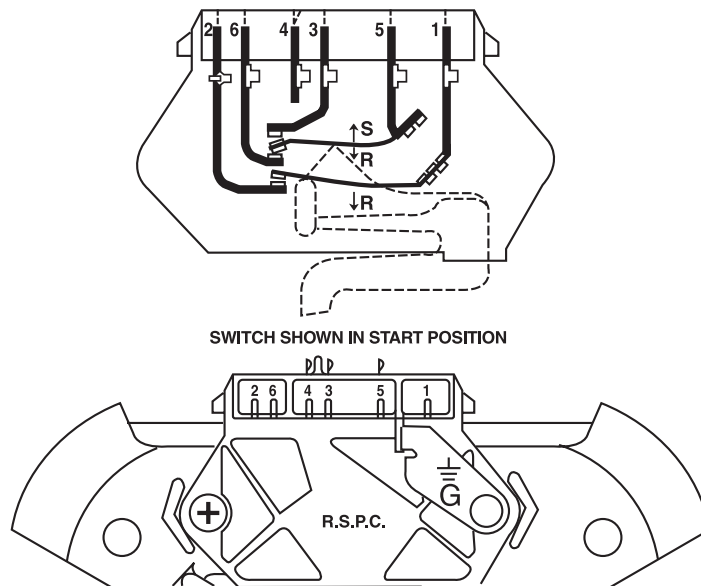

■ STOP MODE
 (When Motor does not operate)

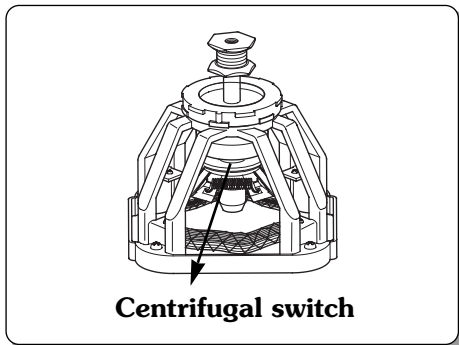

■ RUN MODE
 (Motor operates)

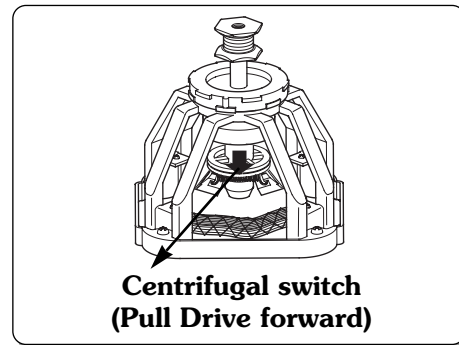

PWB ASSEMBLY DISPLAY LAY-OUT

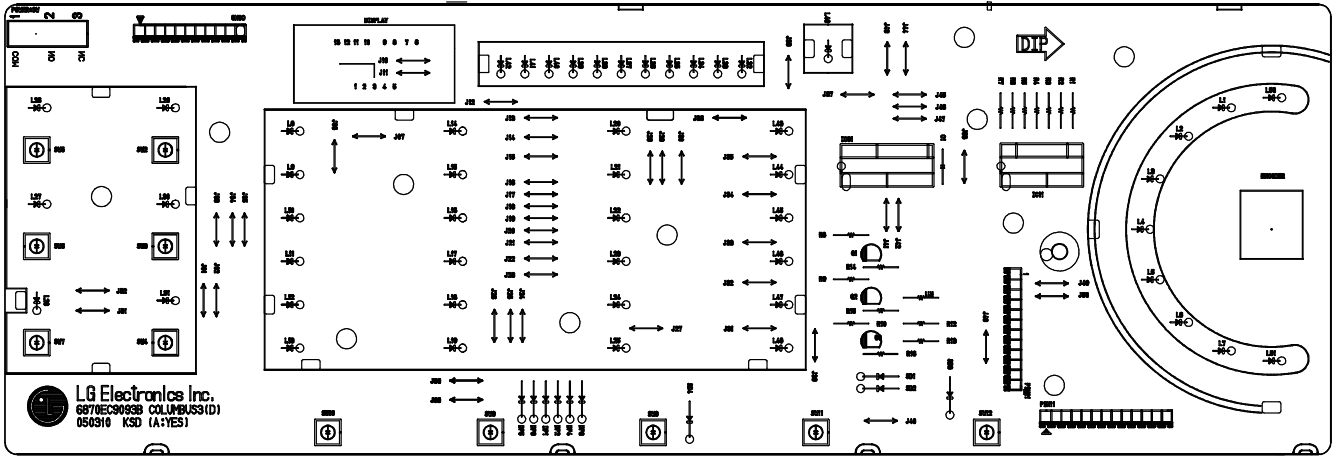

※ MODEL DISPLAY AS DIAGNOSTIC TEST

MODEL	OPTION PART						LED DISPLAY	P/No
	OP 1	OP 2	OP 3	OP 4	OP 5	OP 6		
DLE0442W/S / DLE6942W DLE5944WM	○	X	X	X	X	X	18:23	6871EC2123B
DLG0452W/S / DLG6952W DLG5955WM	○	X	○	X	X	X	19:23	6871EC2123C
DLE2544W	X	○	X	X	X	X	18:25	6871EC2123E
DLG2555W	X	○	○	X	X	X	19:25	6871EC2123F

PWB ASSEMBLY LAY-OUT

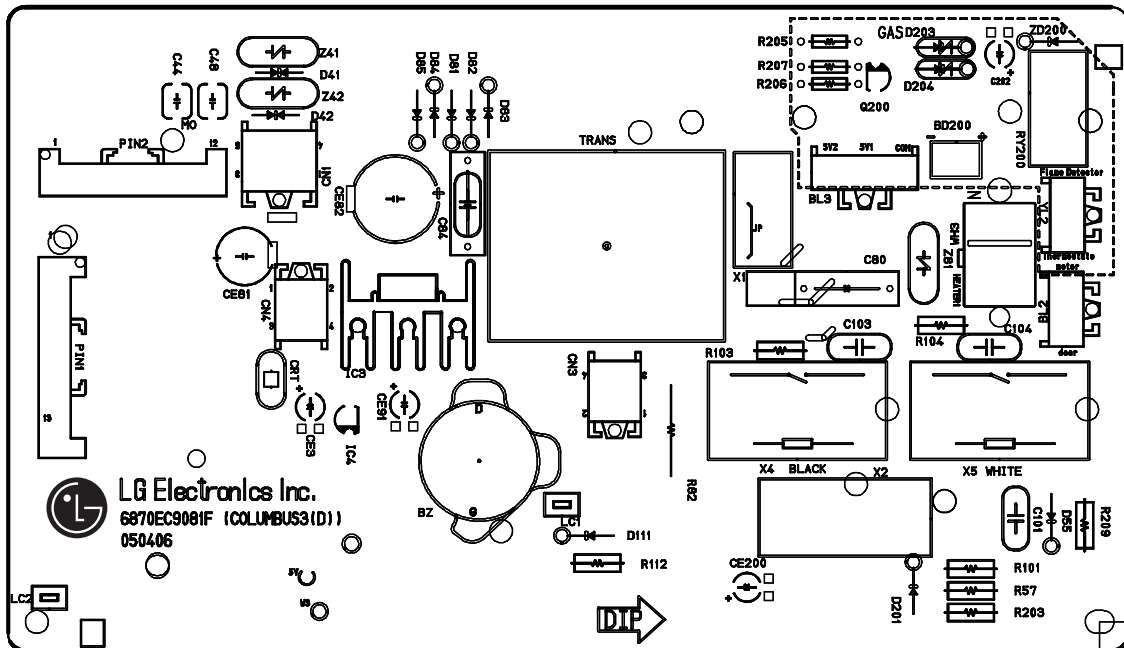

ELECTRIC DRYER WIRING DIAGAM

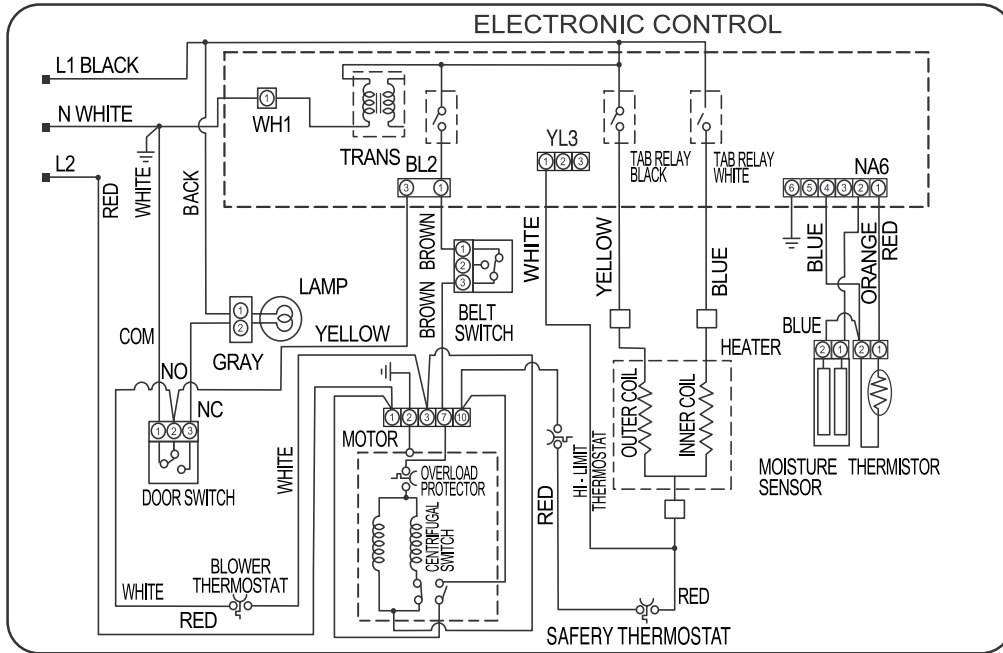

GAS DRYER WIRING DIAGAM

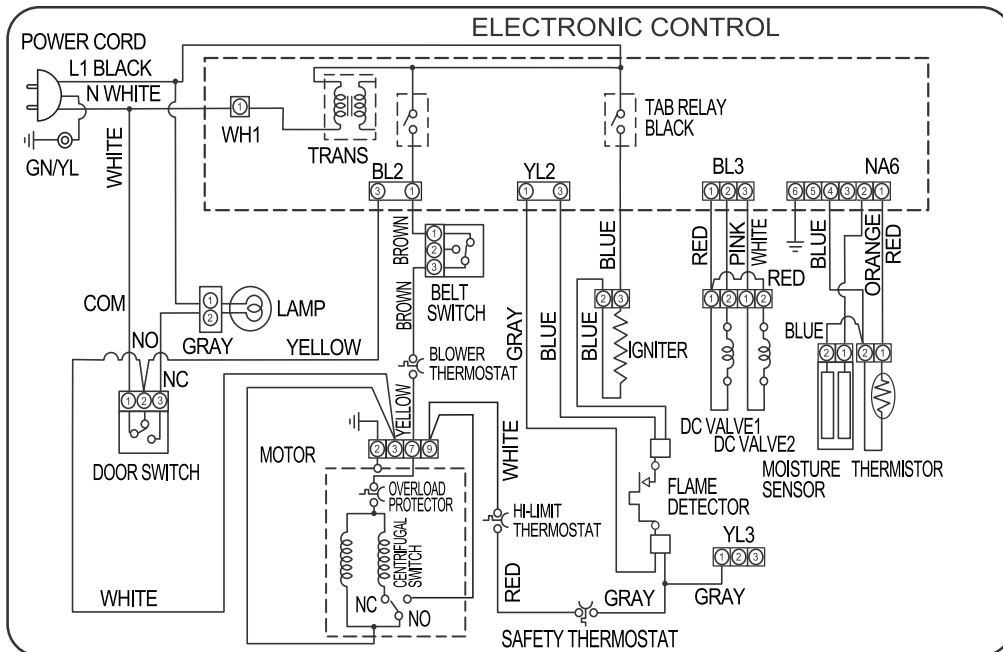

1. This TEST should be used for Factory test /Service test. Do not use this DIAGNOSTIC TEST other than specified.
2. Activating the Heater manually with the Door open may trip the Thermostat attached to the Heater, therefore do not activate it manually. (Do not press the door switch to operate the heater while the door is open)

■ ACTIVATING THE DIAGNOSTIC TEST MODE

1. Unit must be in Standby (unit plugged in, display off)
2. Press **POWER** while pressing **MORE TIME**, and **LESS TIME** simultaneously.

Pressing the START/PAUSE button	CHECKING ACTION	DISPLAY	CHECKING POINT	REMARK
None	Electric control & Temperature sensor	LQC TEST	Won't power up Detective LED or LCD	See test 1 Display: See page
		LQC TEST	Thermistor open	See test 2
		LQC TEST	Thermistor close	
Once	Motor	70 ~ 255 Measured Moisture Value.	Motor runs	See test 3
			Displays Moisture Sensor Operation: If moisture sensor is contacted with damp cloth. The display number is below 180, in normal condition.	See test 4
Twice	<ul style="list-style-type: none"> ■ ELECTRIC TYPE Motor + Heater 1 (2700W) ■ GAS TYPE Motor + Valve 	Current Temp.	<ul style="list-style-type: none"> ■ ELECTRIC TYPE: Heater runs ■ GAS TYPE: GAS Valve runs (Display the Temperature of Inside drum.) 	Gas valve See test 7
3 times	<ul style="list-style-type: none"> ■ ELECTRIC TYPE Motor + Heater 1 +Heater 2 (5400W) ■ GAS TYPE Motor + Valve 	Current Temp. (5 ~ 70)		
4 times	Motor, Heater	50~255 Measured	Motor, Heater Off Semi-conductor	See test 8
		"SE"(Error Display)		
5 times	Control Off			Auto Off
During check, If the door is open.	Motor & Heater Off + Lamp On + Buzzer beeps seven times	"dE" or "Error" (THE DOOR IS OPEN.PLEASE CLOSE THE DOOR COMPLETELY)	Door switch	See test 6
			Lamp	
During check, If the door is closed.	Motor on & Heater Off + Lamp Off	70 ~ 255	<ul style="list-style-type: none"> • Press Start button 1 time and then open the door. Proceed again with the step 1 (by pressing start 1 time), step 2 (by pressing start 2 times), step 3 (by pressing start 3 times) and step 4 (by pressing start 4 times) in sequence. • Press Start 2 times and then open the door. Proceed again from the step 1 all the way to the step 4. • Press Start 3 times and then open the door Proceed with the step 1 and skip the step 2 and press step 3 twice and finish with step 4 by making sure the all the electric devices shut off in the end. 	

■ Test 1 120V AC Electrical supply

Caution	When measuring power, be sure to wear insulated gloves, to and avoid an electric shock.	
Trouble Symptom	No power was applied to Controller. (LED,LCD Display off)	
Measurement Condition	With Dryer Power On; Connector linked to Controller.	
	<p>Check the outlet, is the voltage 110V ~ 125V AC?</p>	<p>NO</p> <ul style="list-style-type: none"> • Check the fuse or circuit breaker.
	<p>YES</p>	
	<p>Check if the voltage measured between Connector BK2 or WH2-② (Black Wire) Linked to the Controller and WH1-① (White Wire) Is 110~125V?</p>	<p>NO</p> <ul style="list-style-type: none"> • Check if Power Cord is properly connected.
	<p>YES</p>	
	<p>① Check if the Controller wire is disconnected. ② Check if Terminal Block and Power Cord are connected (Check Plug). - Does Power Cord N (Natural) line match to Terminal Center N (Natural) line?</p>	<p>NO</p> <ul style="list-style-type: none"> • Reconnect the controller.
	<p>YES</p>	
	<p>Replace controller.</p>	

Caution	When measuring power, be sure to wear insulated gloves, to and avoid an electric shock.
Trouble Symptom	Check the Tab Relays Connection properly.
Measurement Condition	With Dryer Power On; Connector linked to Controller.

1. Power Connection

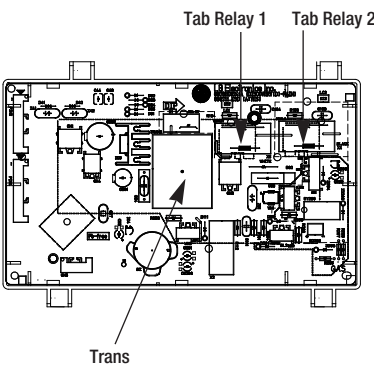

* PCB ASSEMBLY LAYOUT

< Table 1 > : Connection of the Tab Relay with Heater (Elec)

	T a	T a			R
High Mid High Medium	on	on	on	on	Temperature Control below $68 \pm 4^\circ\text{C}$. Turn on Heater1 and Heater2.
Low Extra Low	on	off	on	off	Temperature Control below $52 \pm 4^\circ\text{C}$. Only Turn on Heater1.

< Table 2 > : Connection of the Tab Relay with Burner (Gas)

	T a	B	R
High Mid High Medium	○	○	Temperature Control below $70 \pm 4^\circ\text{C}$. Turn on Burner
Low Extra Low	○	○	Temperature Control below $47 \pm 4^\circ\text{C}$. Turn on Burner

2. Status Mode Of The Connection

< Table 1 > : Connection of Tab Relay with the Tab Relay of the PCB ASSEMBLY (Elec)

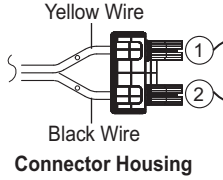
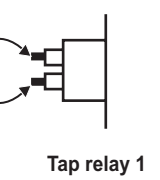
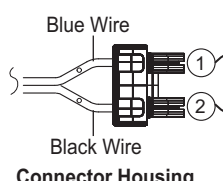
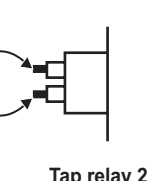
	Color	Connection		Remark
		Harness	PCB	
Connector Housing	Black			Check the Matching color Between Harness wire and Tab Relay. (Black Housing – Black Tab Relay)
	White			Check the Matching color Between Harness wire and Tab Relay. (White Housing – White Tab Relay)

< Table 2 > : Connection of Tab Relay with PCB ASSEMBLY (Gas)

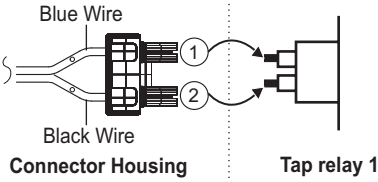
	Color	Harness	PCB	Remark
Connector Housing	Black			Check the Matching color Between Harness wire and Tab Relay. (Black Housing – Black Tab Relay)

3. Status Mode Of wrong Connection

< Table1 > : Wrong Connection of the Tab Relay and Connector Housing (Elec)

Items	Case	Heater1 Operation(black)	Heater2 operation(White)	PCB condition Of operation
1.Black and White Housing	Wire ①, ② CROSS	Off	Off	Power Off
2.Black Housing	Wire ①, ② CROSS	Off	Off	Power Off
3.White Housing	Wire ①, ② CROSS	Normal	Normal	Power On
* 4.Black and White Housing	Housing CROSS	Heater2	Heater1	Power On
5.Black and White Housing	Housing and Wire ①, ② CROSS	Off	Off	Power Off

< Table2 > : Wrong Connection of the Tab Relay and Connector Housing (Gas)

Items	Case	Heater1 Operation(black)	Heater2 operation(White)	PCB condition Of operation
1.Black and White Housing	Wire ①, ② CROSS	Off	Off	Power Off

⚠ CAUTION

- In case of power failure(<Table1>-1,2,5,<Table2>-1), Please check the Connection of "2.Status Table of Connection".
 In case of power failure(<Table1>-4), please check the Connection of "2. Status Table of Connection". Because improper Connection of the equipment-dryer can be damaged of changing heater.

■ Test 2 Thermistor Test --- Measure with Power Off

Caution	Before measuring resistance, be sure to turn Power off, and do voltage discharge. (When discharging, contact the metal plug of Power cord with the Ground.)
Trouble Symptom	<ol style="list-style-type: none"> ① During Diagnostic Test, tE1 and tE2 Error occur. ② During operation, Heater would not turn off, or remains on. ③ Difference between actual and sensed temperature is significant.
Measurement Condition	After turning Power off, measure the resistance.

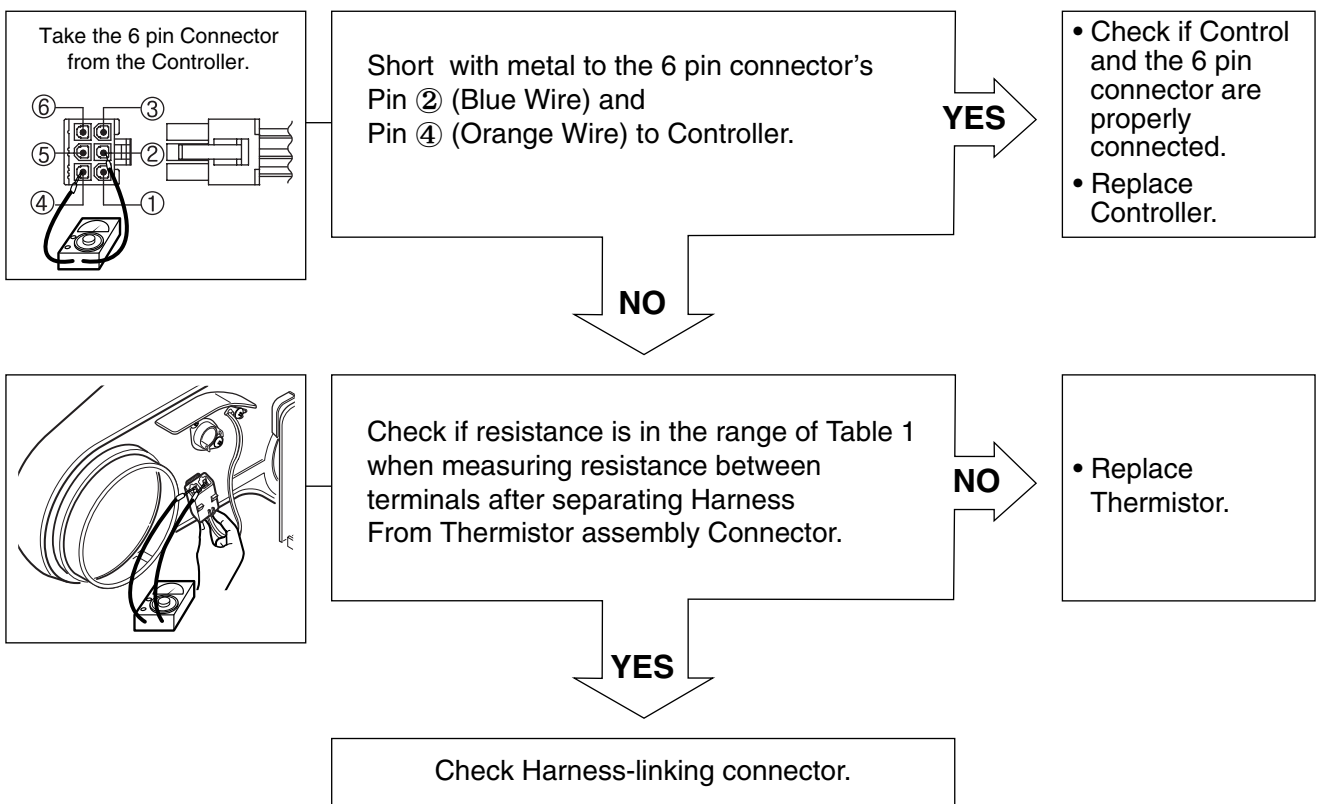

■ Table 1. Resistance for Thermistor Temperature.

Air TEMP.[°F (°C)]	RES. [kΩ]	Air TEMP.[°F (°C)]	RES. [kΩ]	Air TEMP.[°F (°C)]	RES. [kΩ]
50°F (10°C)	18.0	90°F (32°C)	7.7	130°F (54°C)	2.9
60°F (16°C)	14.2	100°F (38°C)	6.2	140°F (60°C)	3.0
70°F (21°C)	11.7	110°F (43°C)	5.2	150°F (66°C)	2.5
80°F (27°C)	9.3	120°F (49°C)	4.3	160°F (71°C)	2.2

■ Test 3 Motor test

<p>Caution</p>	<p>Before measuring resistance, be sure to turn Power off, and do voltage discharge. (When discharging, contact the metal plug of Power cord with earth line.)</p>	
<p>Trouble Symptom</p>	<p>Drum will not rotate; No fan will function; No Heater will work.</p>	
<p>Measurement Condition</p>	<p>Turn the Dryer's Power Off, then measure resistance.</p>	
	<p>Is resistance below 3Ω between Connector WH① (White wire) and BL2-② (Brown wire)? ※ Measure while door is closed.</p> <p>YES</p> <p>NO</p> <p>Is resistance below 3Ω between Connector WH① (White wire) and BL2-① (Yellow wire)? ※ Measure while door is closed.</p> <p>NO</p> <p>YES</p> <p>Is resistance below 3Ω between Connector BL2-① (Yellow wire) and BL2-② (Brown wire)?</p> <p>YES</p> <p>NO</p> <p>Is resistance below 1Ω between terminals of Outlet Thermostat attached to blower housing?</p> <p>NO</p> <p>YES</p> <p>Does Idle Switch attached to Motor Bracket operate Level by drum belt? (Not operating Level is normal.)</p> <p>YES</p> <p>Is resistance below 1Ω between Idler Switch terminals?</p> <p>NO</p> <p>YES</p>	<ul style="list-style-type: none"> • Replace Control. (Relay check) • Check Controller connector. <ul style="list-style-type: none"> • Check if Door flame presses door switch knob. • Check Door Switch. • Check Harness connection. <ul style="list-style-type: none"> • Replace Control. (Relay check) • Check Controller connector. <ul style="list-style-type: none"> • Replace Outlet • Thermostat. (Refer to 'Component') <ul style="list-style-type: none"> • Check Idler Assembly. • Drum Belt cuts off • Drum Belt takes off from Motor Pulley. <ul style="list-style-type: none"> • Replace Idler Switch. <ul style="list-style-type: none"> • Check Motor. (Refer to 'Motor Diagram & Check') • Check if Control Connector is contacted.

■ Test 4 Moisture sensor

Caution	Before measuring resistance, be sure to turn Power off, and do voltage discharge. (When discharging, contact the metal plug of Power cord with earth line.)
Trouble Symptom	Degree of dryness does not match with Dry Level.
Measurement Condition	Turn the Dryer's Power Off, then measure resistance.

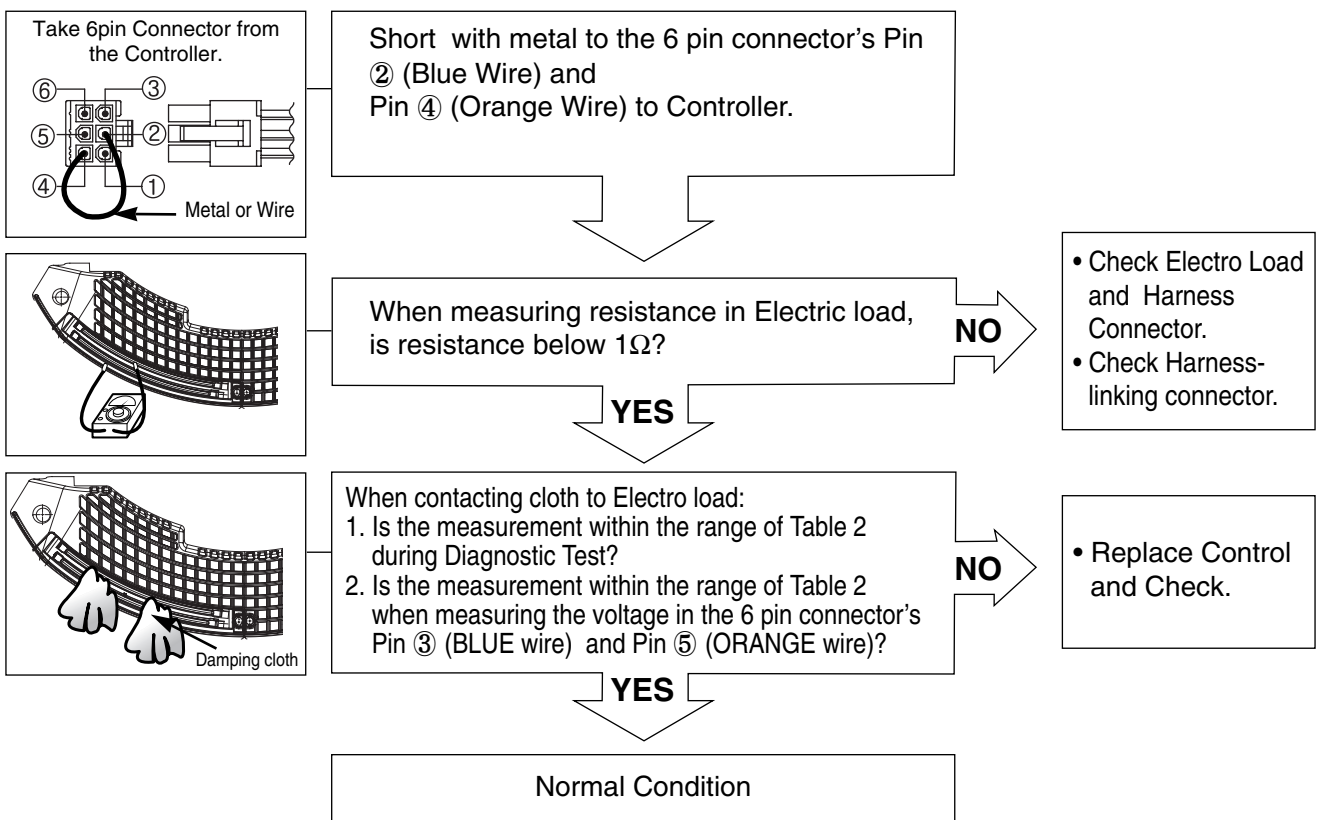

■ Table 2. IMC Ratio and Display Value / Voltage (IMC: Initial Moisture Content)

IMC	Display Value	Voltage (DC) (between 6 Pin terminal ③,⑤)	Remark
70% ~ 40%	50 ~ 130	2.5V	Weight after removing from Washing Machine
40% ~ 20%	130 ~ 20	2.0V ~ 4.0V	Damp Dry
10% ~ Dried clothes	205 ~ 240	Over 4.0V	Completely-dried clothes

■ Test 5 Door switch test

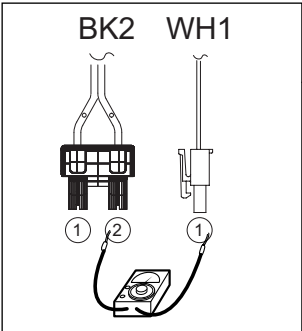
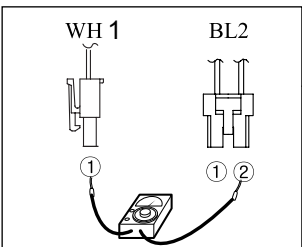
<p>Caution</p>	<p>Before measuring resistance, be sure to turn Power off, and do voltage discharge. (When discharging, contact the metal plug of Power cord with earth line.)</p>	
<p>Trouble Symptom</p>	<p>Door Opening is not sensed.(During operation, when opening Door, Drum motor and Heater run continuously) Door Close is not sensed. (Drum motor will not operate. Display will flash at 0.5 second intervals.)</p>	
<p>Measurement Condition</p>	<p>After turning Dryer Power Off, measure resistance.</p>	
 	<p>Measure while Door is closed. Check it resistance is below 2500 Ω between WH1-①(White wire) and BK2-② Connector WH1,BL2 after taking WH1,BL2 out from Controller.</p> <p style="text-align: right;">YES</p> <p style="text-align: center;">NO</p> <p>Measure while Door is open. Check it resistance is 300~60 Ω between WH1-①(White wire) and BK2-② (Black wire). Connector WH1,BL2 after taking WH1,BL2 out from Controller.</p> <p style="text-align: right;">NO</p> <p style="text-align: center;">YES</p> <p>Measure while Door is open. Check it resistance is below 1 Ω between BL2- ①(Yellow wire) and WH1-①(White wire) after taking Connector WH1,BL2 out from Controller.</p> <p style="text-align: right;">YES</p> <p style="text-align: center;">NO</p> <p>Measure while Door is closed. Check it resistance is below 1 Ω between BL2- ①(Yellow wire) and WH1-①(White wire) after taking Connector WH1,BL2 out from Controller.</p> <p style="text-align: right;">NO</p> <p style="text-align: center;">YES</p> <p style="text-align: center;">Check Controller. Check Harness-linking connector.</p>	<ul style="list-style-type: none"> • Door switch Check (Refer to Component testing.) <ul style="list-style-type: none"> • Check Lamp. (When opening Lamp, replace then measure again.) • Door switch Check(Refer to Component testing.) <ul style="list-style-type: none"> • Door switch Check (Refer to Component testing.) <ul style="list-style-type: none"> • Door switch Check (Refer to Component testing.)

■ Test 6 Heater switch test - Electric Type

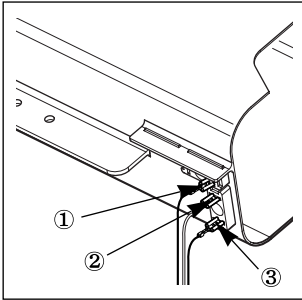
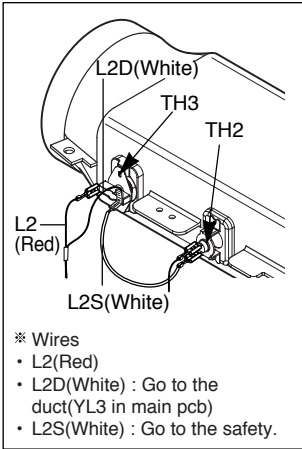
<p>Caution</p>	<p>Before measuring resistance, be sure to turn Power off, and do voltage discharge. (When discharging, contact the metal plug of Power cord with earth line.)</p>	
<p>Trouble Symptom</p>	<p>While operating, Heating will not work. Drying time takes longer.</p>	
<p>Measurement Condition</p>	<p>After turning Power off, measure the resistance.</p>	
	<ol style="list-style-type: none"> 1. Is resistance between Heater terminal ① and ② below 18 ~ 22Ω? 2. Is resistance between Heater terminal ① and ③ below 18 ~ 22Ω? 3. Is resistance between Heater terminal ② and ③ below 9 ~ 11Ω? 	<p>NO</p> <ul style="list-style-type: none"> • Replace Heater.
<p>YES</p>		
 <p>※ Wires</p> <ul style="list-style-type: none"> • L2(Red) • L2D(White) : Go to the duct(YL3 in main pcb) • L2S(White) : Go to the safety. 	<p>Check if the value of measured resistance is 1Ω between terminal TH2 (Safety Thermostat).</p>	<p>NO</p> <ul style="list-style-type: none"> • Replace TH2 (Safety Thermostat).
<p>YES</p>		
<p>Check if the value of measured resistance is below 1Ω between terminal TH3 (HI-Limit Thermostat).</p>	<p>NO</p> <ul style="list-style-type: none"> • Replace TH3 (HI-Limit Thermostat). 	
<p>YES</p>		
<p>Check Motor. Check if the value of measured resistance is below 1Ω between terminal ① and ⑩ at RUN condition.</p>	<p>NO</p> <ul style="list-style-type: none"> • Check Motor and replace it. 	
<p>YES</p>		
<p>Check Controller. Check Harness-linking Connector.</p>		

■ Test 7 GAS Valve test - Gas Type

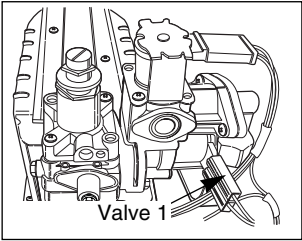
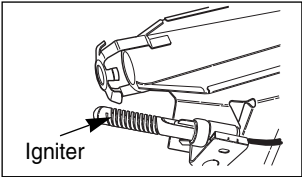
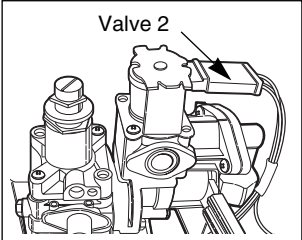
Caution	When measuring power, be sure to wear insulated gloves, to avoid electric shock.	
Trouble Symptom	While operating, Heating will not work. Drying time takes longer.	
Measurement Condition	With dryer power on	
	<p>Power On & Start (Normal Cycle)</p> <p style="text-align: center;">NO</p>	
	<p>When measuring Valve 1 voltage, More than DC 90V?</p> <p style="text-align: right;">NO →</p>	<ul style="list-style-type: none"> • Check thermostat Hi limit Safety
	<p>Igniter operates? (after 1 min, Igniter becomes reddish)</p> <p style="text-align: right;">NO →</p>	<ul style="list-style-type: none"> • Check Igniter & Frame detect
	<p>When measuring Valve 2 voltage, Value is more than DC 90V? (10 sec after Igniter off)</p> <p style="text-align: right;">YES →</p>	<ul style="list-style-type: none"> • Check Gas connection or Gas supply
	<p style="text-align: center;">NO</p>	
	<p>When measuring terminal resistance on Valve 1 and Valve 2, Valves are more than 1.5 ~ 2.5kΩ? (Measure after Off)</p> <p style="text-align: right;">YES →</p>	<ul style="list-style-type: none"> • Change Valve
	<p style="text-align: center;">NO</p>	
	<p>If "Valve 1 " and "Valve 2" are under DC 10V, Valves are Off?</p> <p style="text-align: right;">NO →</p>	<ul style="list-style-type: none"> • Change Valve
	<p style="text-align: center;">YES</p>	
	<ul style="list-style-type: none"> • Harness check • Controller change 	

Warning After Natural Gas Setting, applying Propane Gas Orifice or wrong use of Natural Gas Orifice will result in fire. Conversion must be made by a qualified technician.

Initially, Natural Gas mode is set. Propane Gas Orifice is on sale as a Service Part to authorized servicers only.

STEP 1 : VALVE SETTING

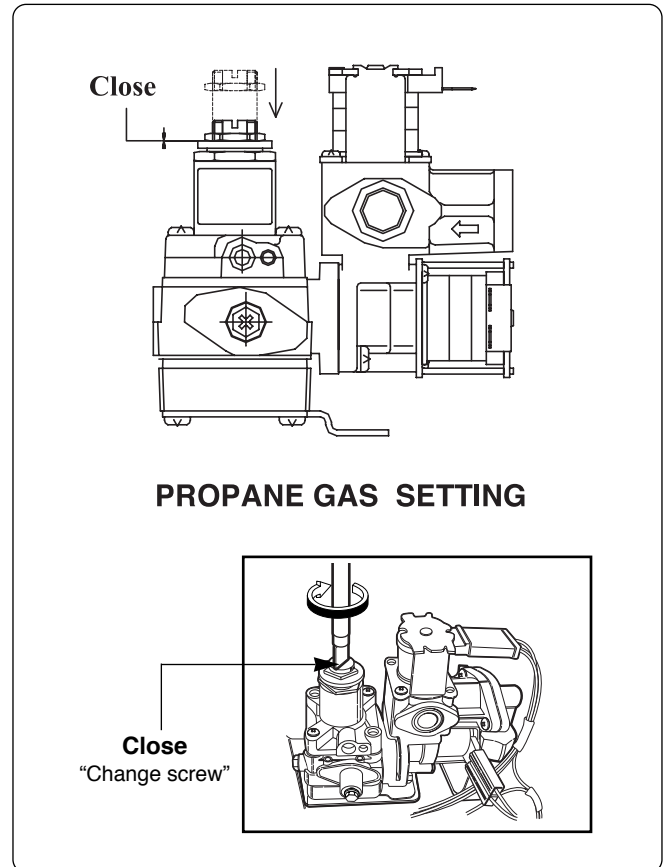
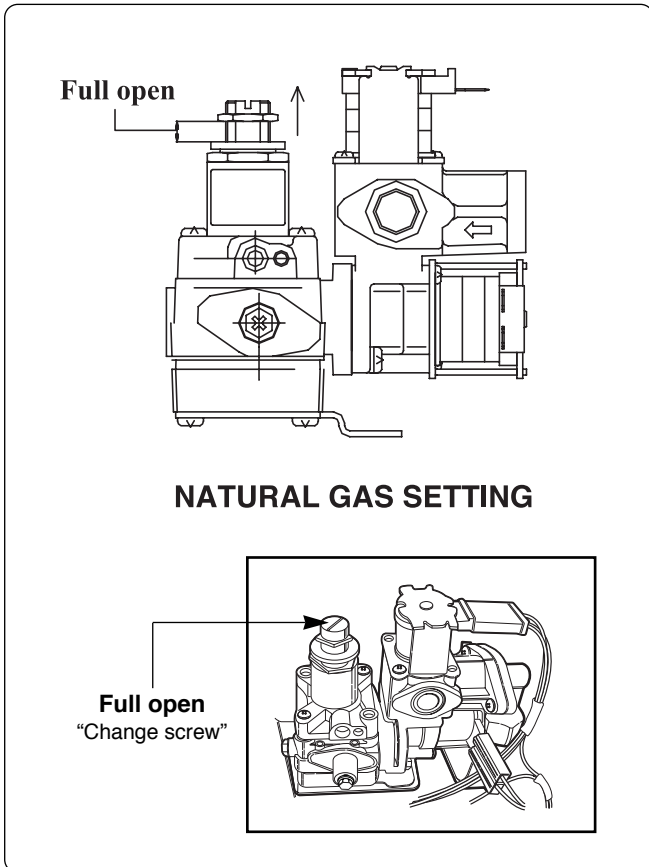

STEP 2 : ORIFICE CHANGE

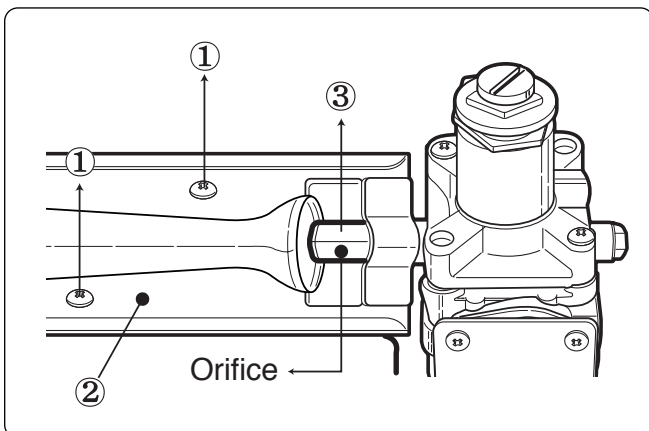

- ① Remove 2 screws.
- ② Disassemble the pipe assembly.
- ③ Replace Natural Gas orifice with Propane Gas orifice.

Gas type	Orifice P/No	Marking	Shape
Natural Gas	4948EL4001B	NCU	
Propane Gas	4948EL4002B	PCU	

※ **Kit contents** : Orifice (Dia. = 1.613mm, for Propane Gas)
 : Replace Label
 : Instruction sheet

■ GAS VALVE FLOW

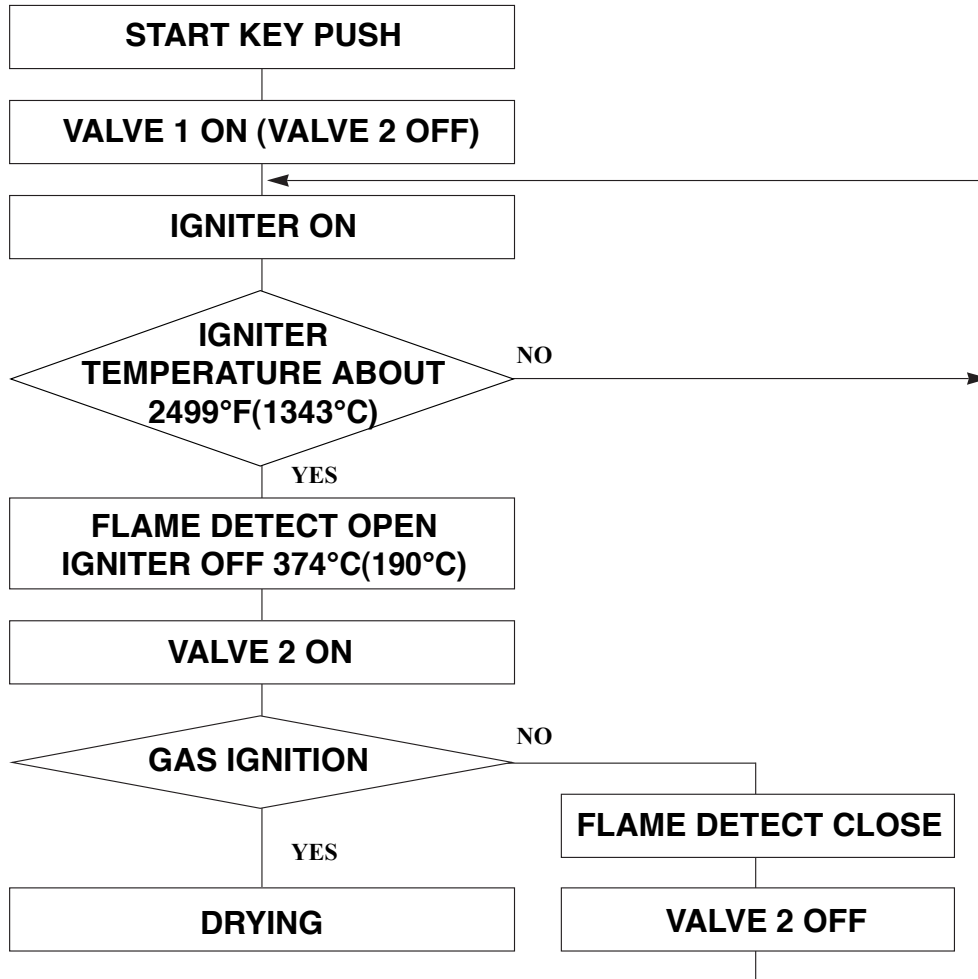

GAS IGNITION

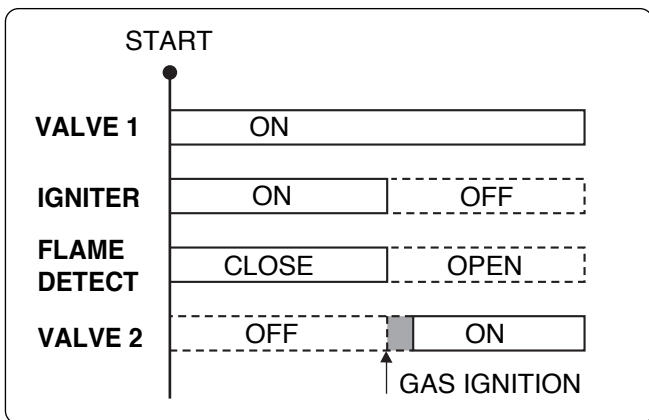

GAS VALVE STRUCTURE

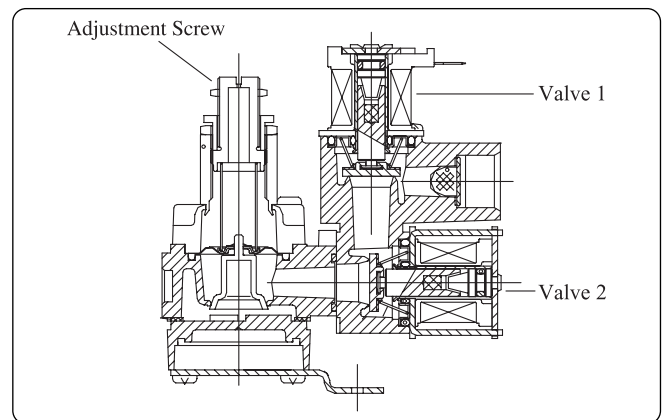

11

DISASSEMBLY INSTRUCTIONS

* Disassemble and repair the unit only after pulling out power plug from the outlet.

CONTROL PANEL ASSEMBLY

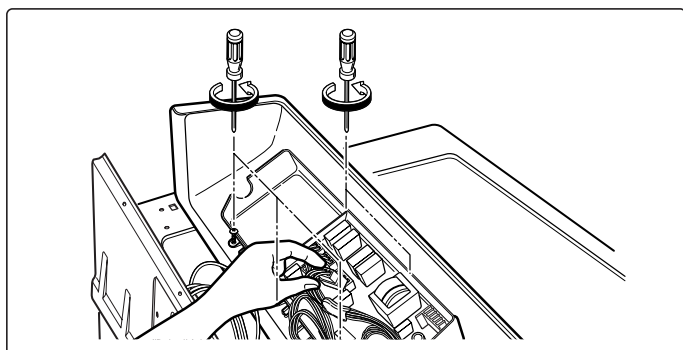
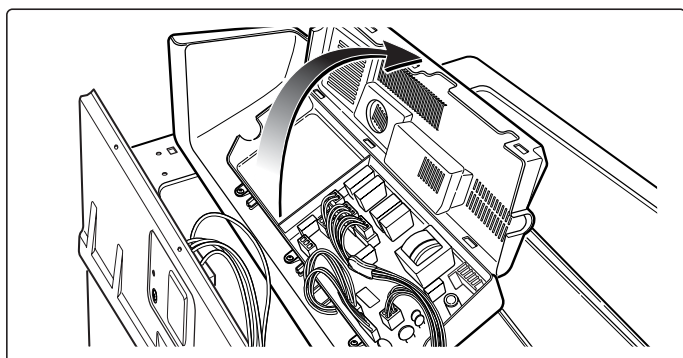
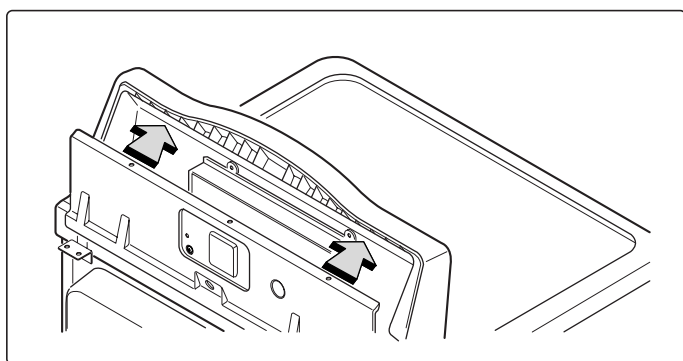
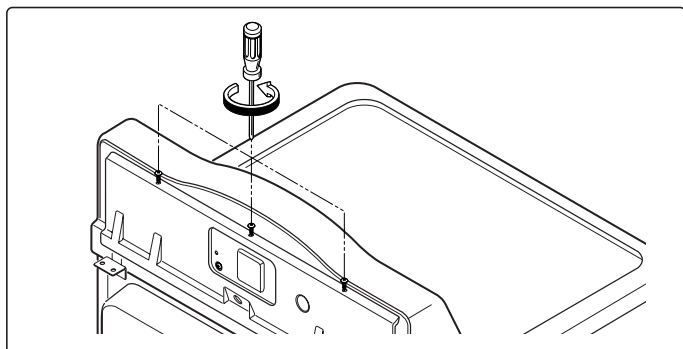

⚠ WARNING !

When you disassemble the control panel, be sure to take gloves and careful panel frame's edge. Failure to do so can cause serious injury.

1. Remove 3 screws on the rear Panel.
2. Pull the control panel forward.
3. Open the cover protect.
4. Disconnect connectors.
5. Remove 5 screws.
6. Disassemble the controller assembly.

TOP PLATE

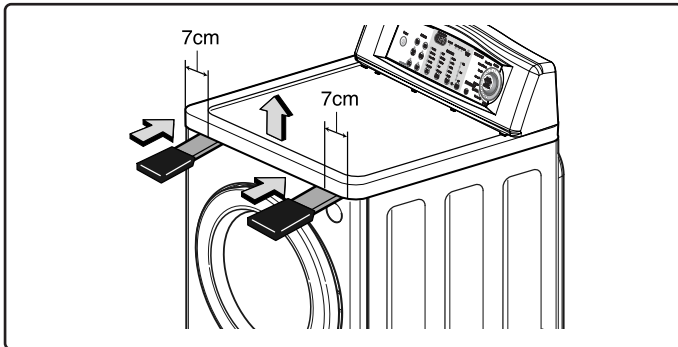

⚠ WARNING

When you disassemble the top plate, be sure to take gloves and careful plate's edge. Failure to do so can cause serious injury.

1. Push backward using an opener and lift the top plate.

COVER CABINET

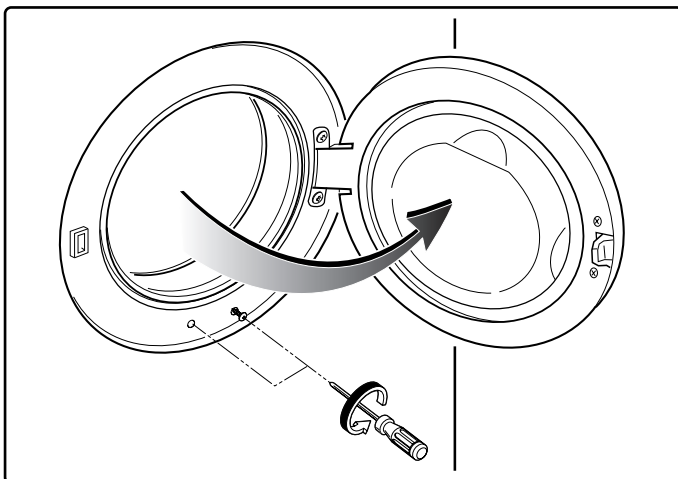

⚠ WARNING

When you disassemble the door switch connector, be sure to take gloves and careful cabinet edge. Failure to do so can cause serious injury.

1. Open the top plate.
2. Open the door, Remove 2 screws.
3. Remove 2 screws form upper side.
4. Pull the Cover Cabinet.
5. Disconnect the door switch connector.

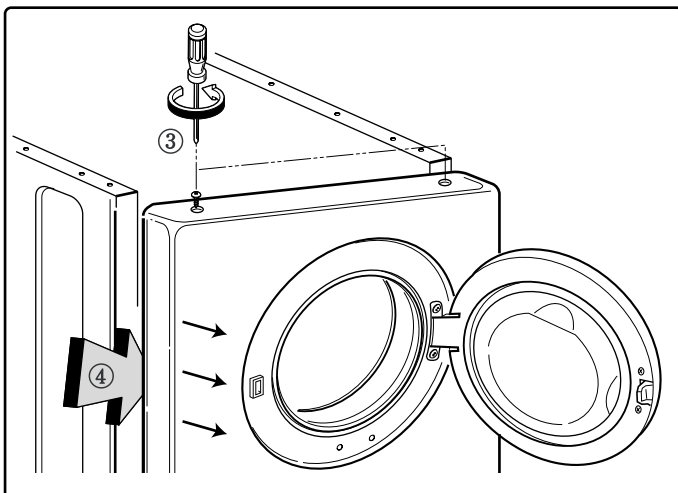

TUB DRUM [FRONT]

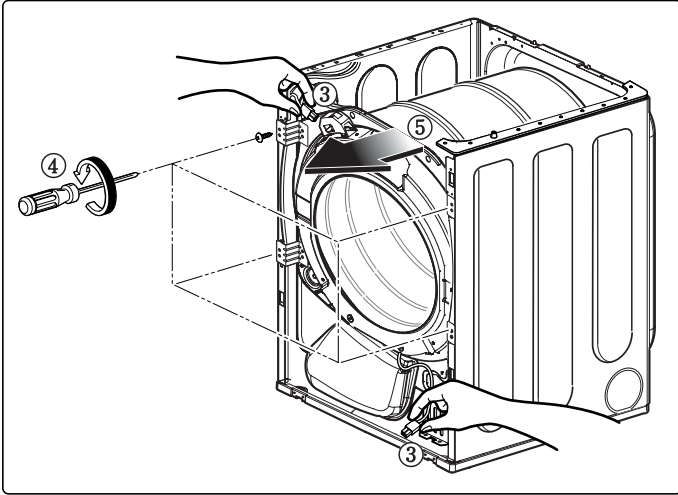

⚠ WARNING !

When you disassemble the lamp connector, be sure to take gloves and careful cabinet edge. Failure to do so can cause serious injury.

1. Open the top plate.
2. Remove Cover Cabinet.
3. Disconnect the door lamp and electro sensor connector.
4. Remove 4 screws.
5. Disassemble the Tub Drum [Front].

DRUM ASSEMBLY

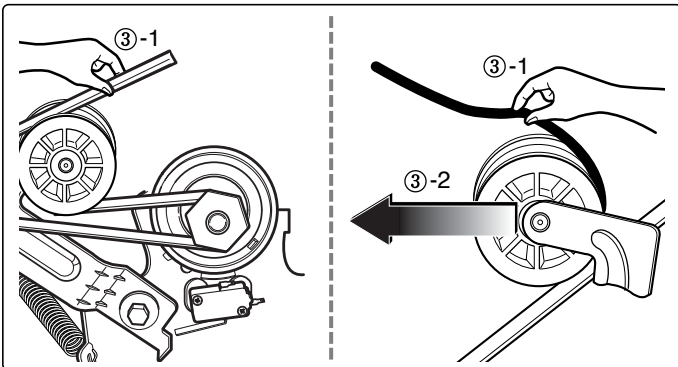

1. Open the top plate.
2. Remove the Cover Cabinet and Tub drum [front].
3. Disengage belt from motor and idler pulleys.
4. Carefully remove Drum out through front of dryer.

CHANGING THE DRUM LAMP

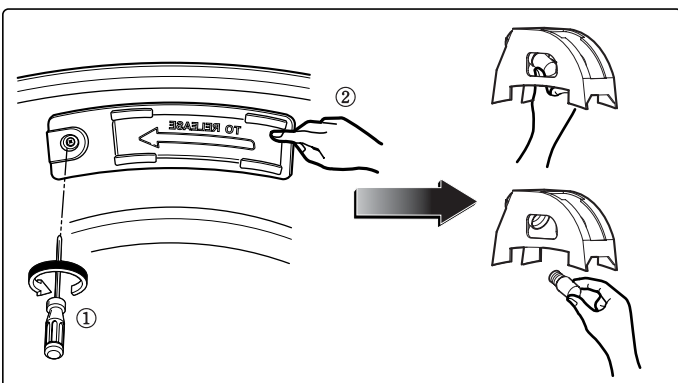

1. Open the door.
2. Remove the screw holding the drum lamp shield in place.
3. Slide the shield up and remove.
4. Remove the bulb and replace with a 15 watt, 120 volt candelabra-base bulb.
5. Replace the lamp shield and screw.

DRYER EXHAUST CHANGE

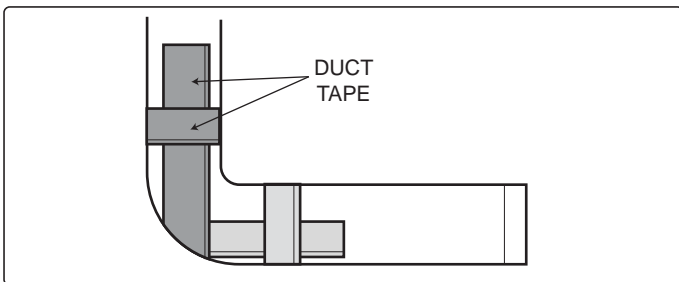
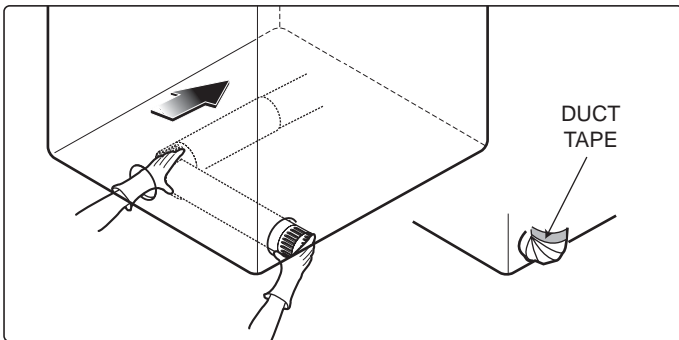
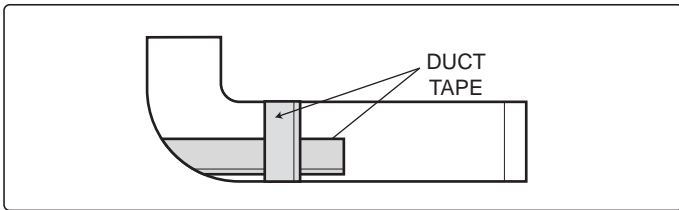
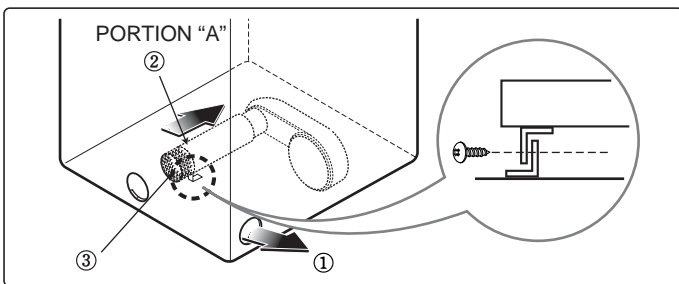
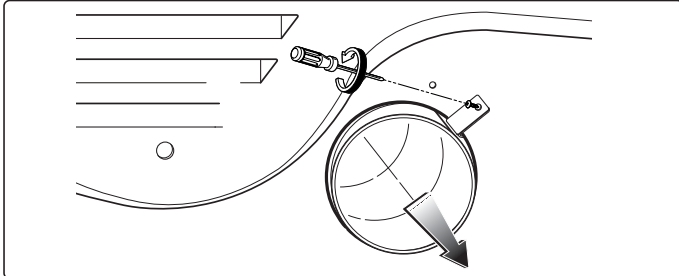

⚠ WARNING !

When you disassemble and install ventilation, be sure to take gloves and careful exhaust edge. Failure to do so can cause serious injury.

1. Remove screw & exhaust duct.
2. Detach and remove the bottom, left or right side knockout as desired.
3. Reconnect the new duct [11 in (28cm)] to the blower housing, and attach the duct to the base.
4. Pre-assemble 4" elbow with 4" duct. Wrap duct tape around joint.
5. Insert duct assembly, elbow first, through the side opening and connect the elbow to the dryer internal duct.

FILTER ASSEMBLY

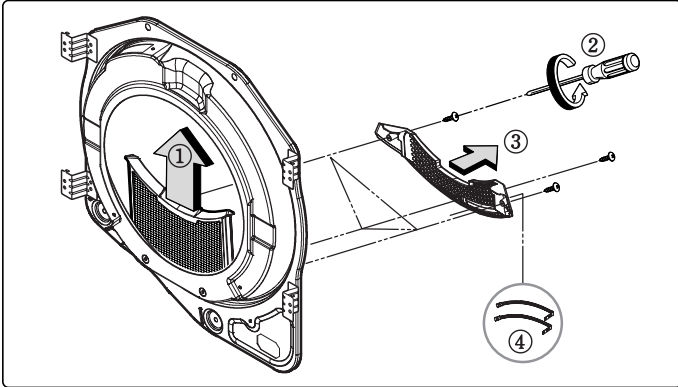

1. Remove the filter.
2. Remove 3 screws.
3. Pull the grill.
4. Disconnect electro sensor.

BLOWER HOUSING

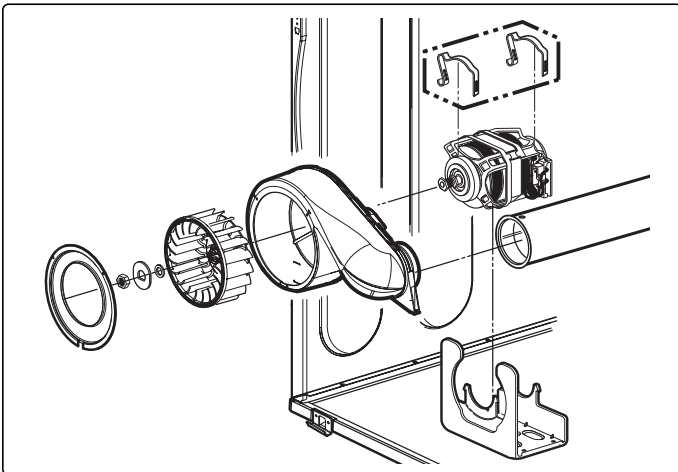

1. Open the top plate.
2. Remove the Cover Cabinet and Tub Drum [Front].
3. Remove the Drum assembly.
4. Remove 2 screws and cover(Air guide).
5. Remove the bolt and washer.
6. Pull the fan.
7. Disconnect the motor clamp and motor.

BACK COVER

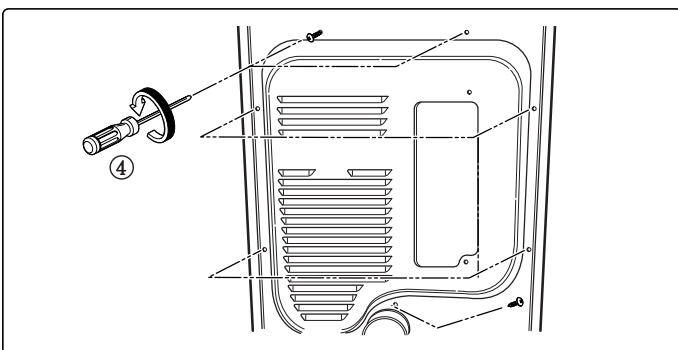

1. Open the top plate.
2. Remove the Cover Cabinet and Tub Drum [Front].
3. Remove the Drum assembly.
4. Remove 7 screws.
5. Pull the Tub Drum [Rear] towards the front.

AIR DUCT

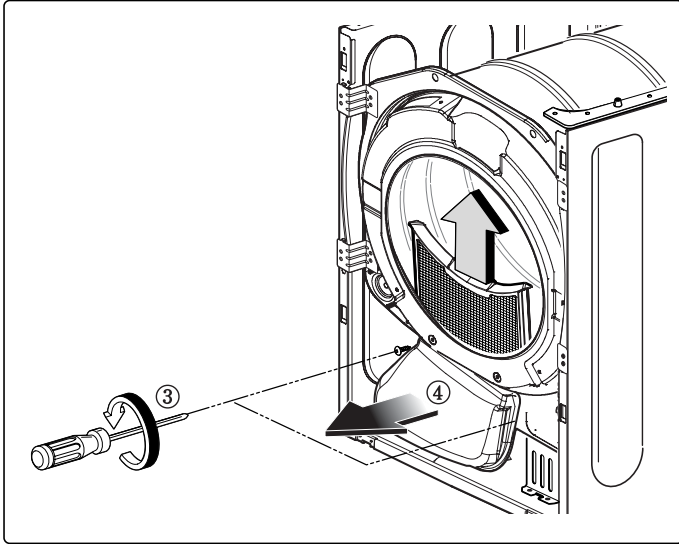

1. Open the top plate.
2. Remove the Cover Cabinet.
3. Remove filter and 2 screws.
4. Pull the air duct towards the front.

ROLLERS

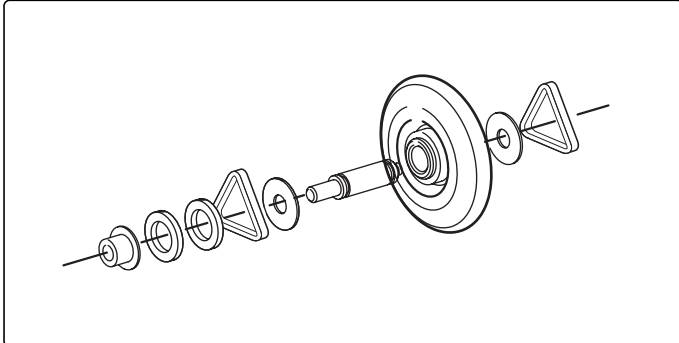

1. Open the top plate.
2. Remove the Cover Cabinet and Tub Drum [Front].
3. Remove the Drum assembly and Tub Drum [Rear].
4. Disconnect Air duct from the Tub Drum [Front].
5. Remove the roller from the Tub Drum [Front] and Tub Drum [Rear].

12

EXPLODED VIEW

12-1. Control Panel & Plate Assembly

"The following parts are not illustrated"		
	Description	LOC NO.
Printed materials	* Owner's Manual	(G001)
	* Sheet, Operation	(G003)
	* Manual, Service	(G004)
	* Sheet, Operation	(G007)

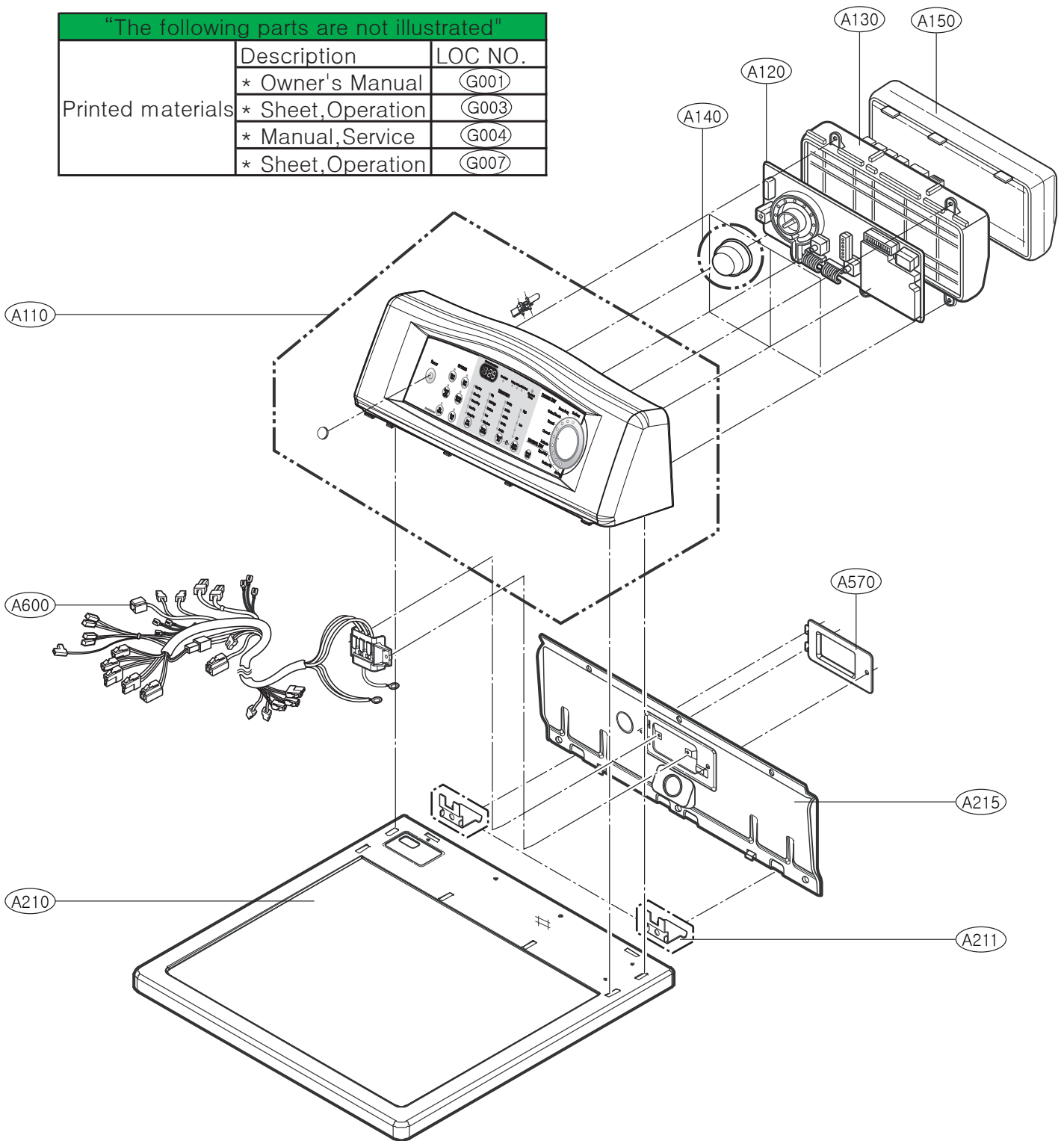

12-2. Cabinet & Door Assembly

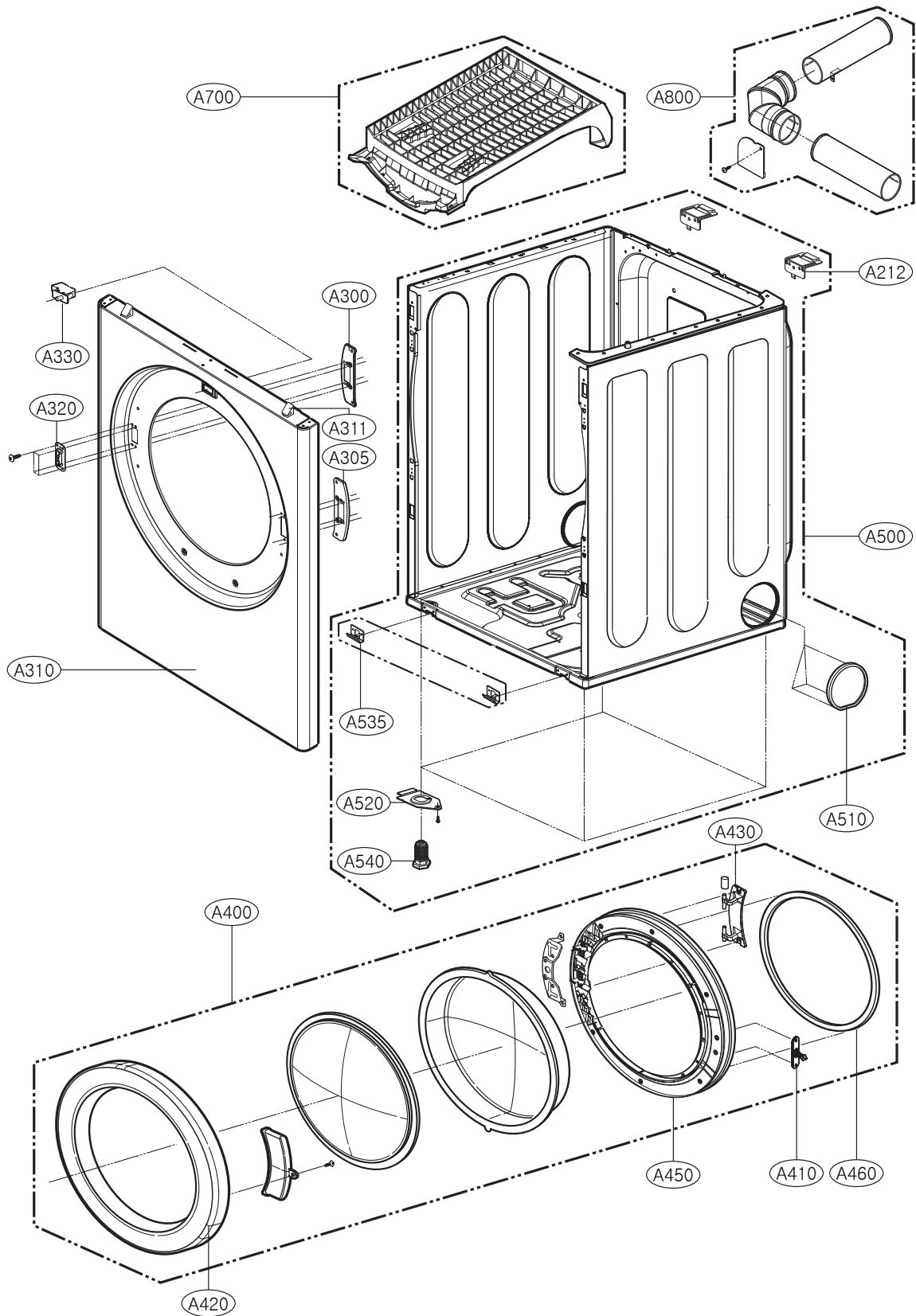

12-3-2. Drum & Motor Assembly : Gas type

