

**READ BEFORE USE**  
**LIRE AVANT UTILISATION**  
**LEA ANTES DE USAR**

Visit [hamiltonbeach.com](http://hamiltonbeach.com) for delicious recipes, tips, and to register your product online!



Consultez [hamiltonbeach.ca](http://hamiltonbeach.ca) pour de délicieuses recettes, des conseils pratiques et pour enregistrer votre produit !

¡Visite [hamiltonbeach.com.mx](http://hamiltonbeach.com.mx) para recetas deliciosas, consejos, y para registrar su producto en línea!

**Questions?**

Please call us – our friendly associates are ready to help.  
USA: 1.800.851.8900

**Questions?**

N'hésitez pas à nous appeler – nos associés s'empresseront de vous aider.  
CAN: 1.800.267.2826

**¿Preguntas?**

Por favor llámenos – nuestros amables representantes están listos para ayudar.

MEX: 01 800 71 16 100

Le invitamos a leer cuidadosamente este instructivo antes de usar su aparato.

**Hamilton  
Beach®**

*20-Cup Rice Cooker*  
*Cuiseur de riz*  
*Ollas para cocer arroz*



English .....	2
Français .....	10
Español .....	18

## IMPORTANT SAFEGUARDS

When using electrical appliances, basic safety precautions should always be followed to reduce the risk of fire, electric shock, and/or injury to persons, including the following:

1. Read all instructions.
2. Do not touch hot surfaces. Use handles or knobs. Use pot holders when removing hot containers.
3. To protect against a risk of electrical shock do not immerse cord, plug, or base in water or other liquid.
4. Close supervision is necessary when any appliance is used by or near children.
5. Unplug from outlet when not in use. Unplug before putting on or taking off parts and allow to cool before cleaning.
6. Do not operate any appliance with a damaged cord or plug or after the appliance malfunctions, has been dropped or damaged in any manner. Call our toll-free customer service number for information on examination, repair, or adjustment.
7. The use of accessory attachments not recommended by the appliance manufacturer may cause injuries.
8. Do not use outdoors.
9. Do not let cord hang over edge of table or counter, or touch hot surfaces.
10. Do not place on or near a hot gas or electric burner, or in a heated oven.
11. Extreme caution must be used when moving an appliance containing hot food, water, or other hot liquids.
12. To disconnect, make sure the cook switch is pushed up to the "up" position; then remove plug from wall outlet.
13. Do not use appliance for other than intended use.
14. Lift and open cover carefully to avoid scalding, and allow water to drip into the cooker.
15. **Caution:** Risk of electric shock. Cook only in removable container.
16. Do not place the unit directly under cabinets when operating as this product produces large amounts of steam. Avoid reaching over the product when operating.

## SAVE THESE INSTRUCTIONS!

### OTHER CONSUMER SAFETY INFORMATION

**This appliance is intended for household use only.**

**WARNING!** Shock Hazard: This appliance has a polarized plug (one wide blade) that reduces the risk of electric shock. The plug fits only one way into a polarized outlet. Do not defeat the safety purpose of the plug by modifying the plug in any way or by using an adapter. If the plug does not fit, reverse the plug. If it still does not fit, have an electrician replace the outlet.

The length of the cord used on this appliance was selected to reduce the hazards of becoming tangled in, or tripping over a longer cord. If a longer cord is necessary, an approved extension cord may be used. The electrical rating of the extension cord must be equal to or greater than the rating of the appliance. Care must be taken to arrange the extension cord so that it will not drape over the countertop or table-top where it can be pulled on by children or accidentally tripped over.

# Parts and Features

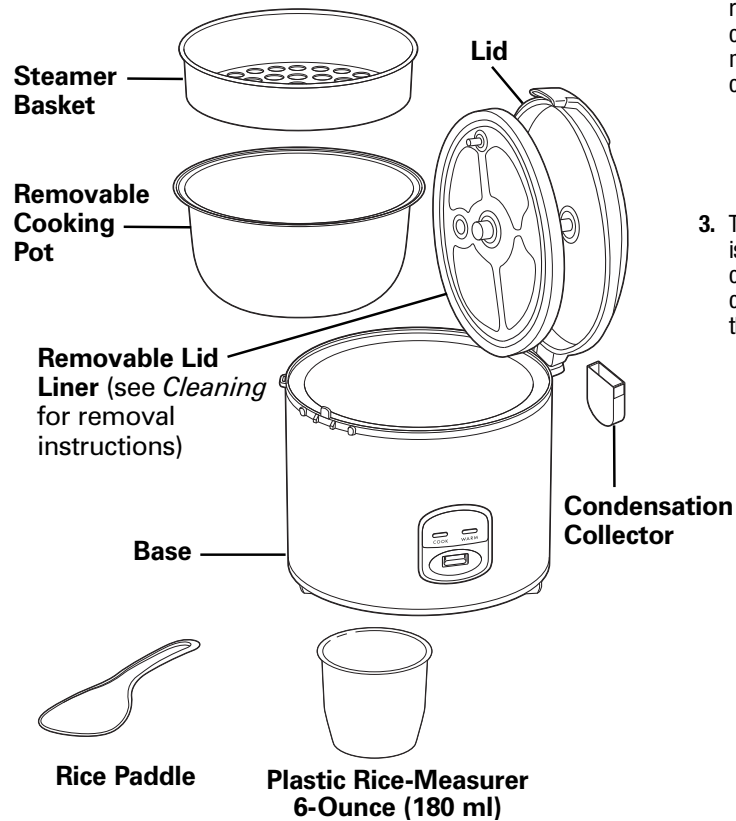

## BEFORE FIRST USE

1. Wash cooking pot and lid following the "Cleaning" instructions in this Use & Care Guide. Dry thoroughly.
2. Do not throw away the plastic rice-measurer that came with your unit. This is an important tool in using your rice cooker successfully and its size is standard in the rice industry. One rice-measurer cup does not equal one standard U.S. cup (plastic rice-measurer is 6 oz/180 ml or approximately  $\frac{3}{4}$  U.S. cup). When directed to use "1 cup" for either rice or water, this means use one full, level rice-measurer cup. Most rice package directions are listed in terms of rice-measurer cups.



3. The most important detail when cooking rice is the ratio of rice to water. A good general ratio is two parts water to one part rice (please see illustration above). If for some reason you lose or misplace the plastic rice-measurer, measure BOTH rice and water using a standard U.S. cup—your rice will turn out just as well. To prevent overflow and/or overheating, do not exceed the 10-cup line when both rice and water are added to cooking pot.

## COOK and WARM Indicator Lights

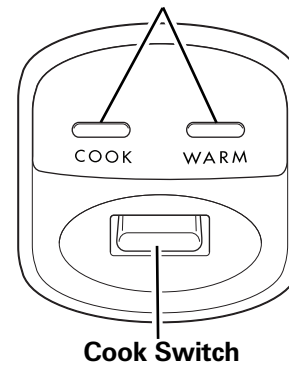

# How to Make Rice

**CAUTION: Electrical Shock Hazard.** Cook only in removable cooking pot. Never place water or food directly into base.

**BEFORE FIRST USE:** Wash cooking pot and removable lid liner.

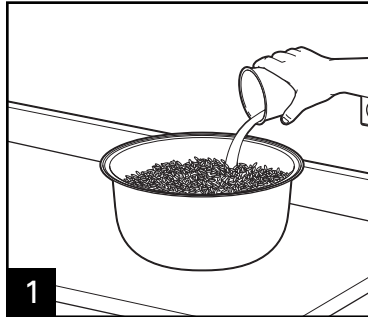

**1** Add desired amount of uncooked rice to cooking pot; then fill with water to the corresponding water line. Example: For 3 cups of rice, add 3 level rice-measurer cups of rice and then add water to the "3" line. Do not exceed 10-cup fill line.

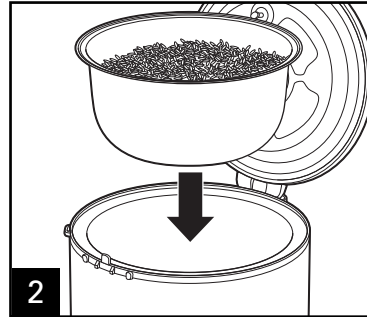

**2** Carefully place cooking pot straight down on base. Make sure cooking pot is securely seated by rotating the pot left and right. **NOTE:** Make sure bottom of cooking pot is not bent or warped, or it will not conduct heat correctly.

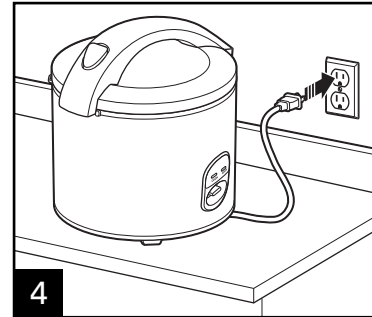
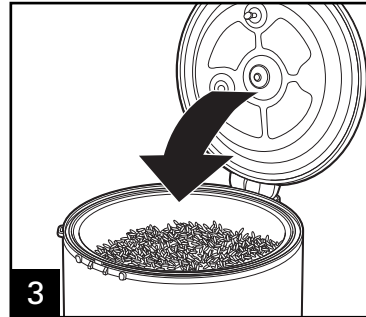

**4** Cooker is in WARM mode when plugged in but the unit IS NOT COOKING.

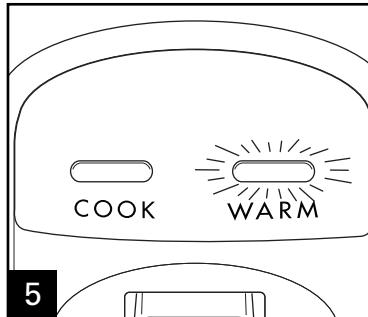

**4**

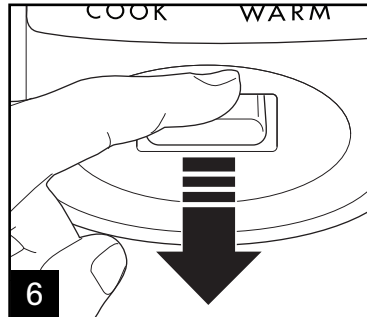

**6** Push cook switch DOWN to start cooking. **NOTE:** During cooking, remove and empty condensation cup as needed then replace.



**7** COOK light indicator will come on and rice will begin cooking. Cooking times will be approximately what is listed on rice package.

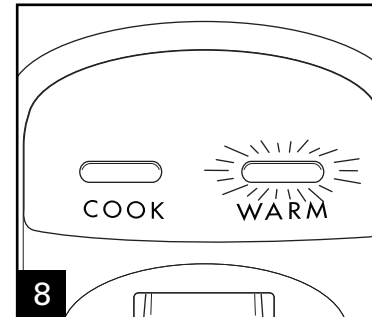

**8** When finished cooking, cooker will switch to WARM and light will glow. The unit will keep rice warm until it is unplugged.

## How to Make Rice (cont.)

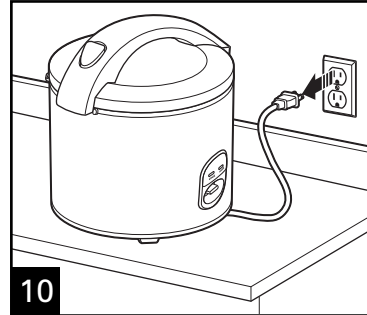
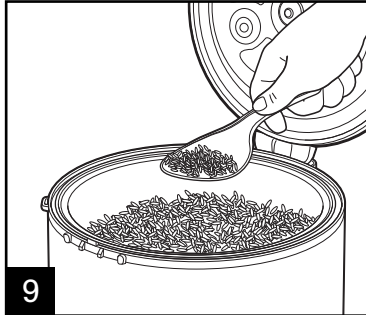

**WARNING! Burn Hazard.** Never use lid handle to carry cooker when contents are hot.

## How to Steam Food

**CAUTION: Electrical Shock Hazard.** Cook only in removable cooking pot. Never place water or food directly into the base.

**BEFORE FIRST USE:** Wash cooking pot and removable lid liner.

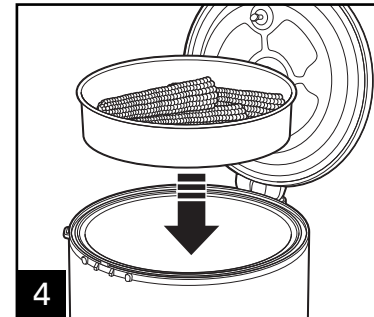
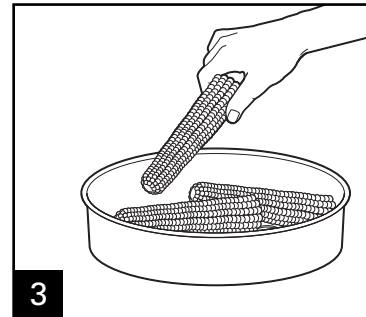
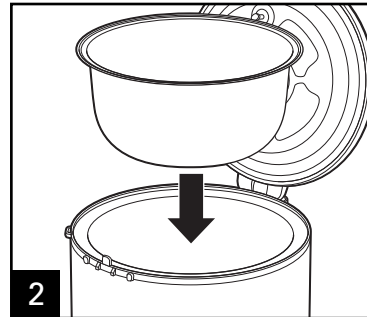
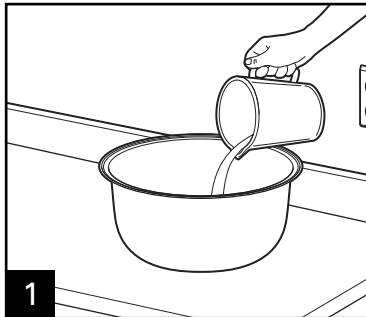

Carefully place cooking pot straight down on base. Make sure cooking pot is securely seated by rotating the pot left and right. **NOTE:** Make sure bottom of cooking pot is not bent or warped, or it will not conduct heat correctly.

## How to Steam Food (cont.)

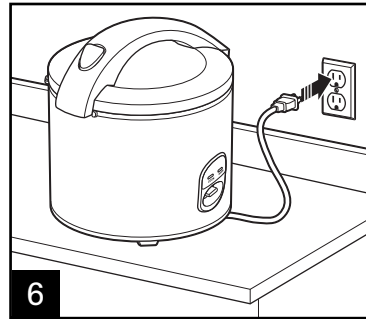
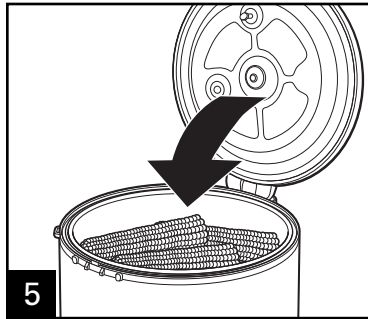

Cooker is in WARM mode when plugged in.

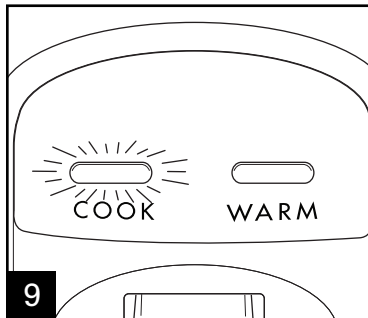
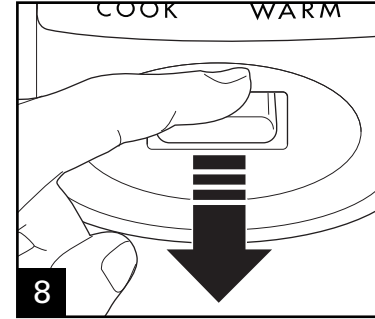
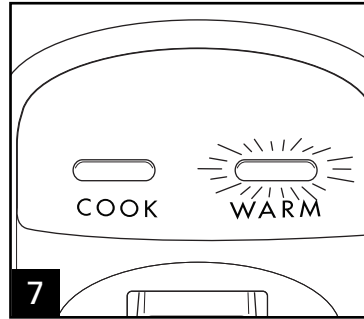

**NOTE:** During cooking, remove and empty condensation cup as needed then replace.

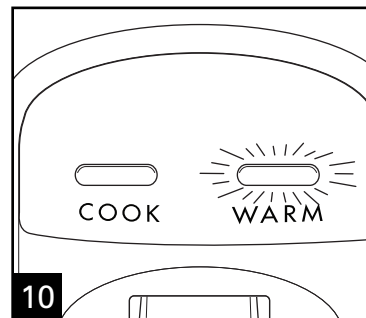

When finished cooking, cooker will automatically switch to WARM and light will glow.

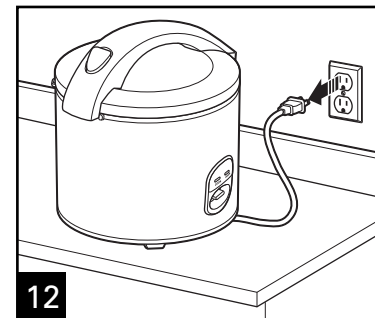
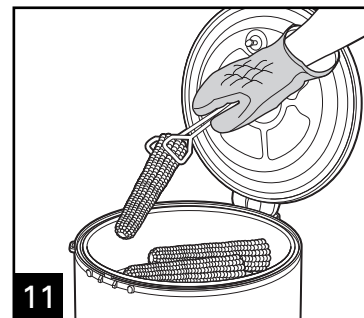

**WARNING! Burn Hazard.** Never use lid handle to carry cooker when contents are hot.

# Cleaning



**WARNING** Electrical Shock Hazard.  
Do not immerse base in water or other liquid.

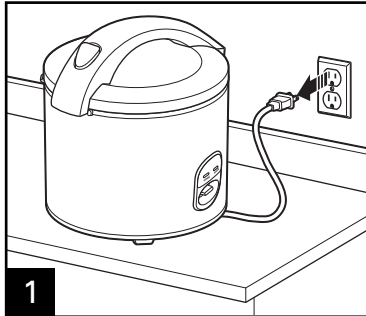

1

**WARNING! Burn Hazard.** Never use lid handle to carry cooker when contents are hot.

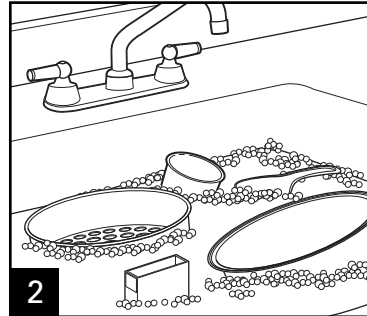

2

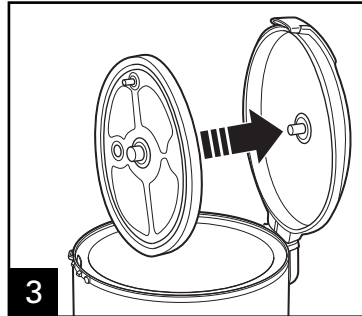

3

Lid liner and condensation cup may be removed to wash by hand. The lid liner may also be placed in the top rack of the dishwasher for easy cleaning.  
To replace the lid liner, simply align the holes and press the liner back into place.

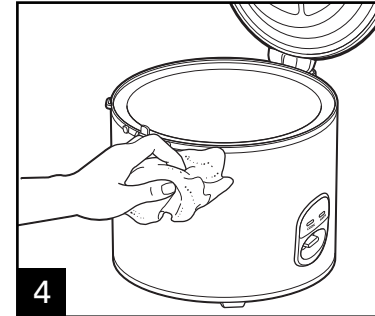

4

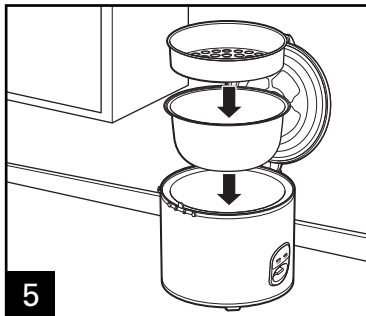

5

## Rice Cooking Chart and Tips

Rice Cooker Cooking Time (approximate). Rice cooker will switch to WARM after cooking time, indicating rice is cooked.  
Serving Size = 3/4 cup (180 g)

TYPE OF RICE	AMOUNT OF UNCOOKED RICE	AMOUNT OF WATER	COOK TIME	SERVES
<b>White</b>				
Min. Amount	2 cups (450 g)	Fill pot to "2" line	15–25 minutes	2–3
Max. Amount	10 cups (2,5 L)	Fill pot to "10" line	30–45 minutes	10–12
<b>Brown</b>				
Min. Amount	2 cups (450 g)	Fill pot to "2" line	25–35 minutes	2–3
Max. Amount	10 cups (2,5 L)	Fill pot to "10" line	40–55 minutes	10–12

- Stir prepackaged, boxed rice mixes at least once during cooking; otherwise, spices may stick to the bottom of the cooking pot. For best results, unplug unit when finished cooking this type of rice. Do not "keep warm."
- Rinsing rice will sometimes increase bubbling during cooking. When cooking a half pot or less of rice, minimize bubbling/overflow by reducing water by about one-third.

- Allowing rice to "rest" for approximately 5–10 minutes after cooking will yield better-textured rice.
- Give rice a flavor boost by substituting an equal amount chicken/beef/vegetable broth for water.

## Troubleshooting

PROBLEM	PROBABLE CAUSE/SOLUTION
Cooker doesn't turn on.	Cooker is not plugged in. Make sure rice cooker is plugged into a properly operating electrical outlet.
Rice is not cooked.	Not enough water/cooking liquid. Follow package directions or see Rice Cooking Chart for more information. Carefully place cooking pot straight down in base. Make sure cooking pot is securely seated by rotating the pot left and right. <b>NOTE:</b> If cooking pot is bent or warped, it will not seat properly in base and, therefore, will not conduct heat correctly. To replace cooking pot, call the toll-free Customer Assistance number listed on the cover of this guide.
Rice is mushy.	Too much liquid added to cooking pot. Reduce liquid.



## *Limited Warranty*

This warranty applies to products purchased in the U.S. and Canada. This is the only express warranty for this product and is in lieu of any other warranty or condition.

This product is warranted to be free from defects in material and workmanship for a period of one (1) year from the date of original purchase. During this period, your exclusive remedy is repair or replacement of this product or any component found to be defective, at our option; however, you are responsible for all costs associated with returning the product to us and our returning a product or component under this warranty to you. If the product or component is no longer available, we will replace with a similar one of equal or greater value.

This warranty does not cover glass, filters, wear from normal use, use not in conformity with the printed directions, or damage to the product resulting from accident, alteration, abuse, or misuse. This warranty extends only to the original consumer purchaser or gift recipient. Keep the original sales receipt, as proof of purchase is required to make a warranty claim. This warranty is void if the product is used for other than single-family household use.

We exclude all claims for special, incidental, and consequential damages caused by breach of express or implied warranty. All liability is limited to the amount of the purchase price. **Every implied warranty, including any statutory warranty or condition of merchantability or fitness for a particular purpose, is disclaimed except to the extent prohibited by law, in which case such warranty or condition is limited to the duration of this written warranty.** This warranty gives you specific legal rights. You may have other legal rights that vary depending on where you live. Some states or provinces do not allow limitations on implied warranties or special, incidental, or consequential damages, so the foregoing limitations may not apply to you.

To make a warranty claim, do not return this appliance to the store. Please call 1.800.851.8900 in the U.S. or 1.800.267.2826 in Canada or visit [hamiltonbeach.com](http://hamiltonbeach.com) in the U.S. or [hamiltonbeach.ca](http://hamiltonbeach.ca) in Canada. For faster service, locate the model, type, and series numbers on your appliance.