

READ BEFORE USE
LIRE AVANT UTILISATION
LEA ANTES DE USAR

Visit hamiltonbeach.com for delicious recipes, tips, and to register your product online!



Consultez hamiltonbeach.ca pour de délicieuses recettes, des conseils pratiques et pour enregistrer votre produit !

¡Visite hamiltonbeach.com.mx para recetas deliciosas, consejos, y para registrar su producto en línea!

Questions?

Please call us – our friendly associates are ready to help.
USA: 1.800.851.8900

Questions ?

N'hésitez pas à nous appeler – nos associés s'empresseront de vous aider.
CAN: 1.800.267.2826

¿Preguntas?

Por favor llámenos – nuestros amables representantes están listos para ayudar.

MEX: 01 800 71 16 100

Le invitamos a leer cuidadosamente este instructivo antes de usar su aparato.

**Hamilton
Beach®**

20-Cup Rice Cooker
Cuiseur de riz
Ollas para cocer arroz

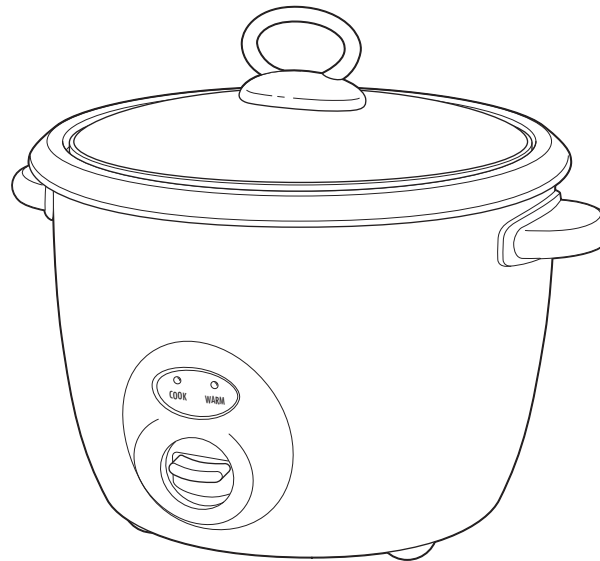

English	2
Français	10
Español	18

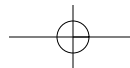
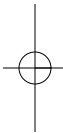

IMPORTANT SAFEGUARDS

When using electrical appliances, basic safety precautions should always be followed to reduce the risk of fire, electric shock, and/or injury to persons, including the following:

1. Read all instructions.
2. Do not touch hot surfaces. Use handles or knobs. Use pot holders when removing hot containers.
3. To protect against a risk of electrical shock do not immerse cord, plug or base in water or other liquid.
4. Close supervision is necessary when any appliance is used by or near children.
5. Unplug from outlet when not in use and before cleaning. Allow to cool before putting on or taking off parts and before cleaning.
6. Do not operate any appliance with a damaged cord or plug or after the appliance malfunctions, has been dropped or damaged in any manner. Call our toll-free customer service number for information on examination, repair or adjustment.
7. The use of accessory attachments not recommended by the appliance manufacturer may cause injuries.
8. Do not use outdoors.
9. Do not let cord hang over edge of table or counter, or touch hot surfaces.
10. Do not place on or near a hot gas or an electric burner, or in a heated oven.
11. Extreme caution must be used when moving an appliance containing hot food, water, or other hot liquids.
12. To disconnect, push up the switch, then remove plug from wall outlet.
13. Do not use appliance for other than intended use.
14. Lift and open cover carefully to avoid scalding, and allow water to drip into the cooking pot.
15. **Caution:** Risk of electric shock, cook only in removable cooking pot.
16. Do not place the unit directly under cabinets when operating as this product produces large amounts of steam. Avoid reaching over the product when operating.

SAVE THESE INSTRUCTIONS!

OTHER CONSUMER SAFETY INFORMATION

This appliance is intended for household use only.

WARNING! Shock Hazard: This appliance has a polarized plug (one wide blade) that reduces the risk of electric shock. The plug fits only one way into a polarized outlet. Do not defeat the safety purpose of the plug by modifying the plug in any way or using an adapter. If the plug does not fit, reverse the plug. If it still does not fit, have an electrician replace the outlet.

The length of the cord used on this appliance was selected to reduce the hazards of becoming tangled in, or tripping over a longer cord. If a longer cord is necessary an approved extension cord may be used. The electrical rating of the extension cord must be equal to or greater than the rating of the appliance. Care must be taken to arrange the extension cord so that it will not drape over the countertop or table-top where it can be pulled on by children or accidentally tripped over.

Parts and Features

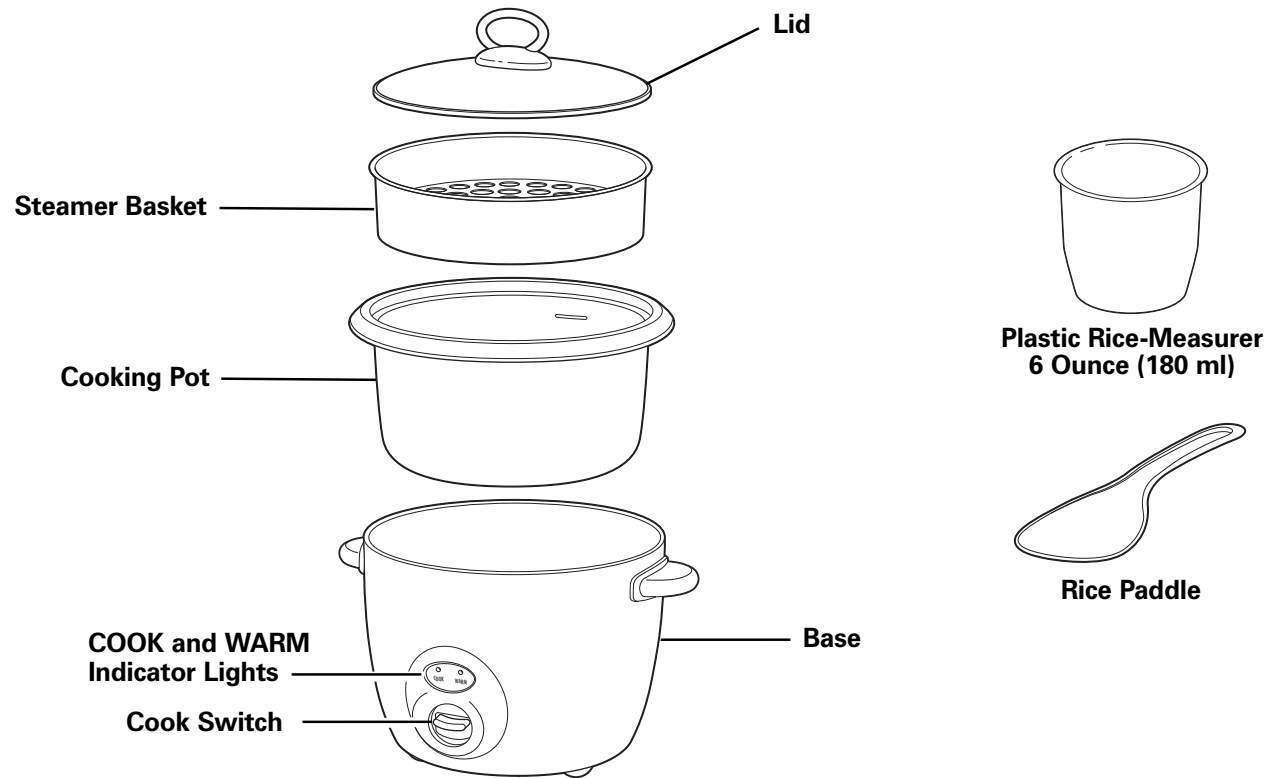

How to Make Rice

⚠ WARNING **Electrical Shock Hazard.** Cook only in removable cooking pot. Never place water or food directly into the base.

BEFORE FIRST USE: Wash cooking pot and lid. See *Cleaning* for details.

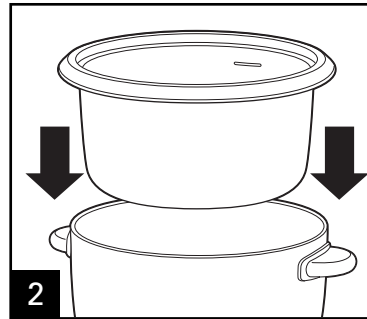
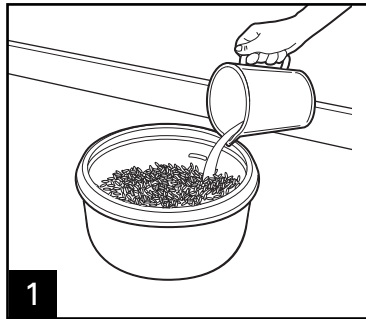

Carefully place cooking pot straight down on base. Make sure cooking pot is securely seated by rotating the pot left and right. **NOTE:** Make sure bottom of cooking pot is not bent or warped, or it will not conduct heat correctly.

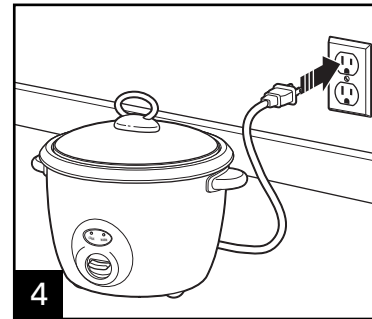
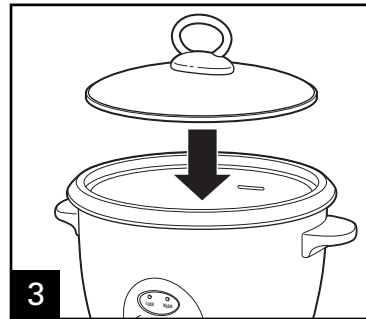

Cooker is in WARM mode when plugged in.

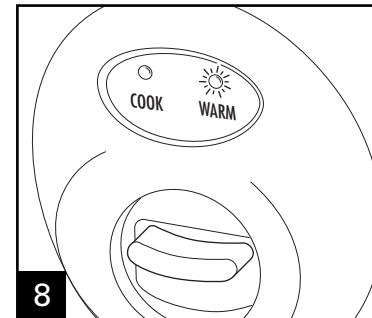
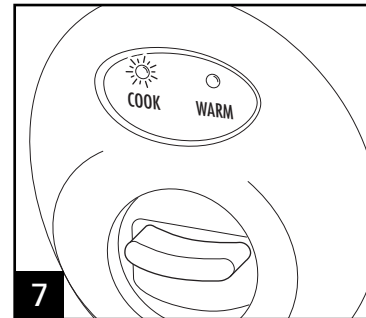
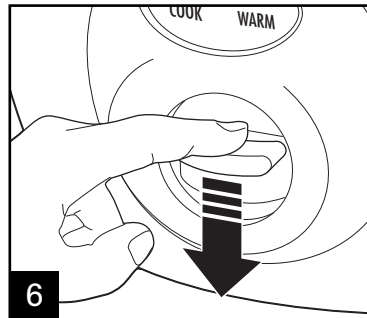
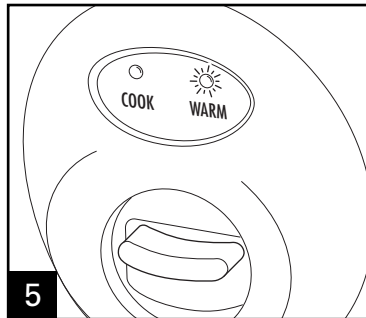

When finished cooking, cooker will automatically switch to WARM and light will glow.

How to Make Rice (cont.)

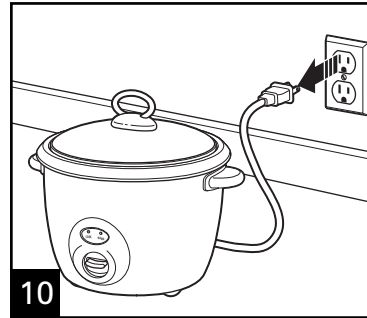
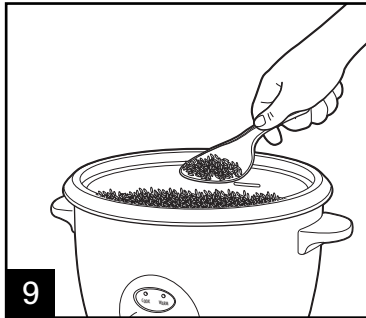

How to Steam Food



WARNING Electrical Shock Hazard. Cook only in removable cooking pot. Never place water or food directly into the base.

BEFORE FIRST USE: Wash cooking pot and lid. See *Cleaning* for details.

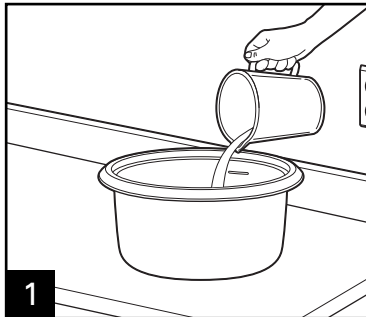

Fill cooking pot half full with water.

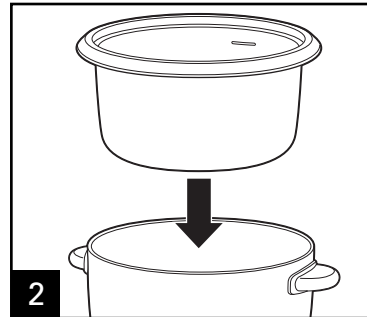

Carefully place cooking pot straight down on base. Make sure cooking pot is securely seated by rotating the pot left and right.
NOTE: Make sure bottom of cooking pot is not bent or warped, or it will not conduct heat correctly.

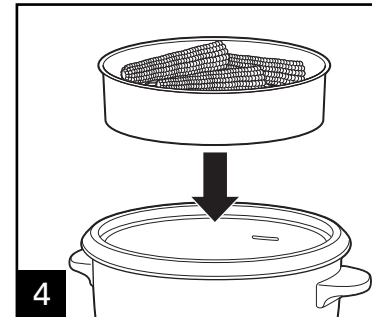
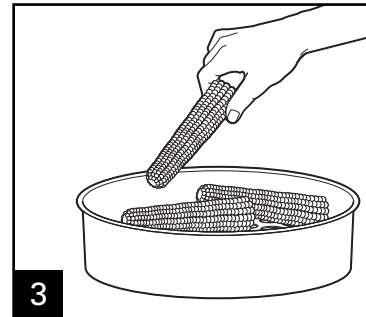

How to Steam Food (cont.)

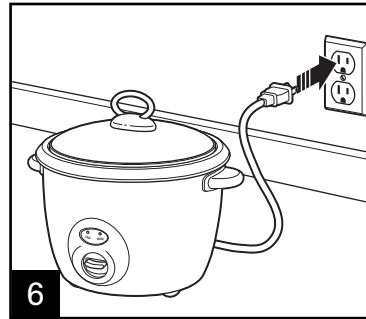
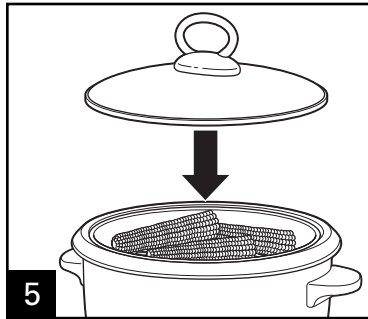

Cooker is in WARM mode when plugged in.

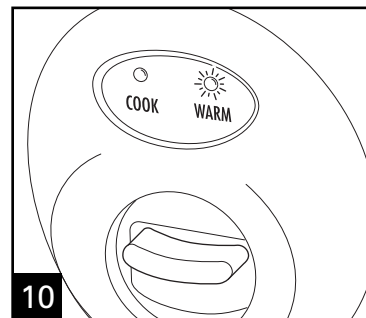
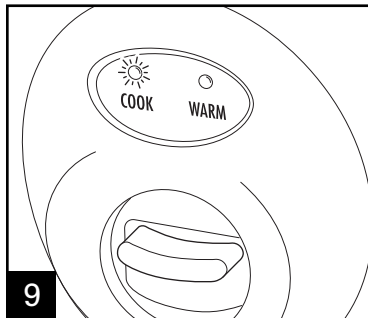
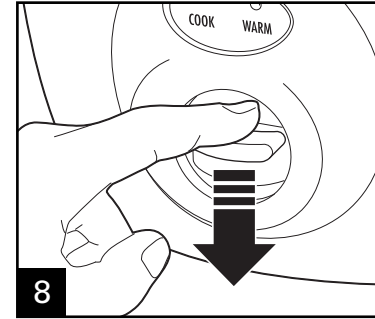
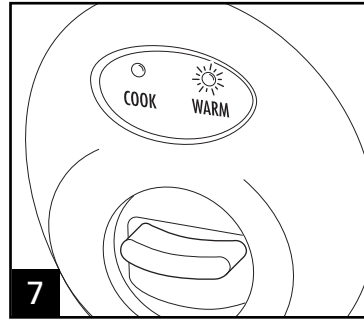

Cook until food has reached desired doneness. **NOTE:** Unit will not automatically shift to WARM mode when steaming food.

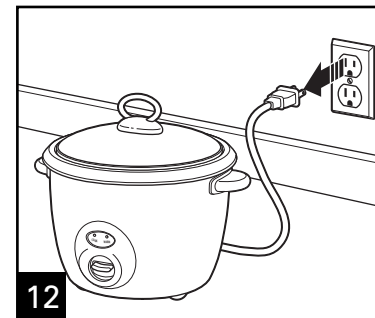
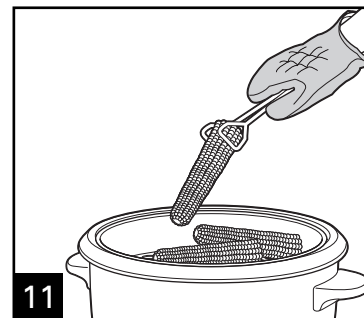

Cleaning

⚠ WARNING

Electrical Shock Hazard.

Do not immerse base in water or other liquid.

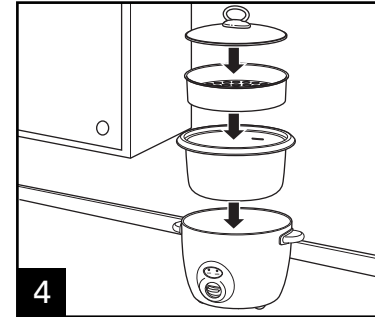
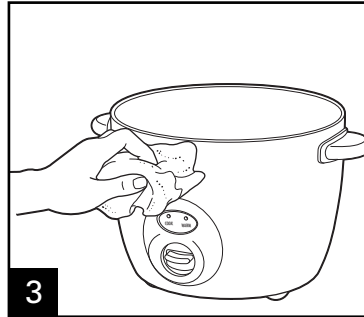
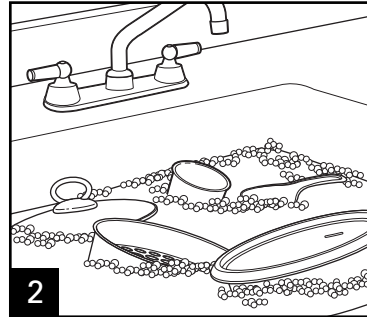
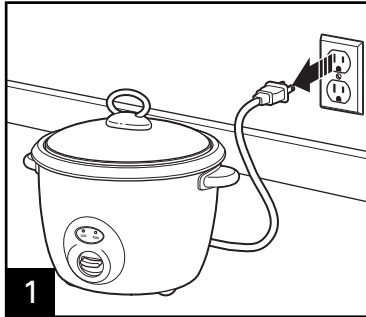

Steamer basket may also be washed in top rack of dishwasher.

Rice Cooking Chart

*Rice Cooker Cooking Time (approximate). Rice cooker will switch to WARM after cooking time, indicating rice is cooked.

**Serving Size = 3/4 cup (175 g)

TYPE OF RICE	AMOUNT OF RICE	AMOUNT OF WATER	COOKING TIME*	SERVES**
Brown, Long Grain	2 cups (450 g)	5 cups (1.25 L)	50 minutes	8 to 10
Brown, Basmati	2 cups (450 g)	4 cups (1 L)	45 minutes	8 to 10
Brown, Short Grain	2 cups (450 g)	4 cups (1 L)	45 minutes	8 to 10
White, Long Grain	2 cups (450 g)	4 cups (1 L)	20-25 minutes	8 to 10
White, Basmati	2 cups (450 g)	3 cups (750 ml)	20 minutes	8 to 10
White, Jasmine	2 cups (450 g)	3 cups (750 ml)	20 minutes	8 to 10
Arborio	2 cups (450 g)	3 cups (750 ml)	20 minutes	8 to 10
Sushi	2 cups (450 g)	3 cups (750 ml)	16-18 minutes (30 minute soak before cooking)	8 to 10
Wild Rice	2 cups (450 g)	6 cups (1.5 L)	60-65 minutes	8 to 10

Troubleshooting

PROBLEM	PROBABLE CAUSE/SOLUTION
Cooker doesn't turn on.	Cooker is not plugged in. Make sure rice cooker is plugged into a properly operating electrical outlet.
Rice is not cooked.	Not enough water/cooking liquid. Follow package directions or see Rice Cooking Chart for more information. Carefully place cooking pot straight down in base. Make sure cooking pot is securely seated by rotating the pot left and right. NOTE: If cooking pot is bent or warped, it will not seat properly in base and, therefore, will not conduct heat correctly. To replace cooking pot, call the toll-free Customer Assistance number listed on the cover of this guide.
Rice is mushy or water overflows in cooking.	Too much liquid added to cooking pot. Reduce liquid.

Limited Warranty

This warranty applies to products purchased in the U.S. and Canada. This is the only express warranty for this product and is in lieu of any other warranty or condition.

This product is warranted to be free from defects in material and workmanship for a period of one (1) year from the date of original purchase. During this period, your exclusive remedy is repair or replacement of this product or any component found to be defective, at our option; however, you are responsible for all costs associated with returning the product to us and our returning a product or component under this warranty to you. If the product or component is no longer available, we will replace with a similar one of equal or greater value.

This warranty does not cover glass, filters, wear from normal use, use not in conformity with the printed directions, or damage to the product resulting from accident, alteration, abuse or misuse. This warranty extends only to the original consumer purchaser or gift recipient. Keep the original sales receipt, as proof of purchase is required to make a warranty claim. This warranty is void if the product is used for other than single-family household use.

We exclude all claims for special, incidental and consequential damages caused by breach of express or implied warranty. All liability is limited to the amount of the purchase price. **Every implied warranty, including any statutory warranty or condition of merchantability or fitness for a particular purpose, is disclaimed except to the extent prohibited by law, in which case such warranty or condition is limited to the duration of this written warranty.** This warranty gives you specific legal rights. You may have other legal rights that vary depending on where you live. Some states or provinces do not allow limitations on implied warranties or special, incidental or consequential damages, so the foregoing limitations may not apply to you.

To make a warranty claim, do not return this appliance to the store. Please call 1.800.851.8900 in the U.S. or 1.800.267.2826 in Canada or visit hamiltonbeach.com in the U.S. or hamiltonbeach.ca in Canada. For faster service, locate the model, type, and series numbers on your appliance.