

This Owner's Manual is provided and hosted by [Appliance Factory Parts](#).

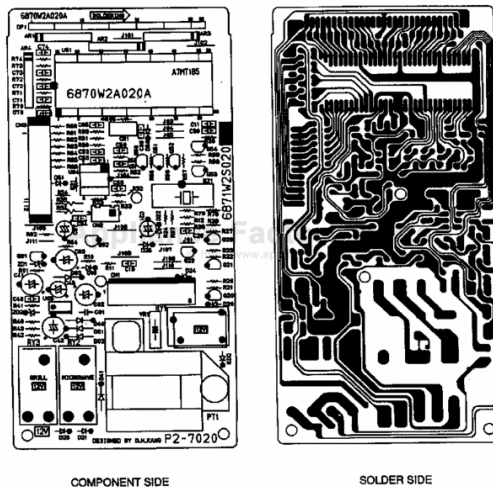

LG 69211 Owner's Manual

[Shop genuine replacement parts for LG 69211](#)



[Find Your LG Microwave Parts - Select From 955 Models](#)

----- Manual continues below -----

SEARS Owner's Manual



MICROWAVE OVEN

Model No. 721.69211

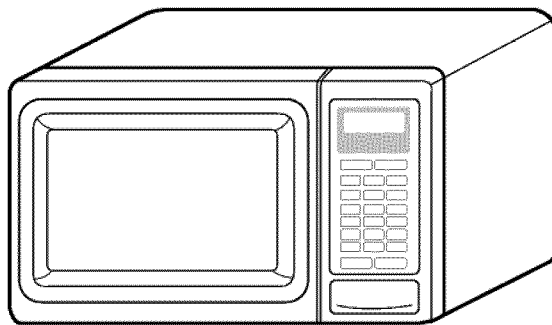

CAUTION: Read and follow all Safety Rules and Operating instructions before First Use of this Product.

Sears, Roebuck and Co., Hoffman Estates, IL. 60179 U.S.A.

SAFETY

INFORMATION

OPERATION

COOKING

TROUBLE SHOOTING

ESPAÑOL

TABLE OF CONTENTS

WARRANTY	2	Microwave Power Levels	11
SAFETY	3~4	Child Lock	11
Precautions To Avoid Possible Exposure		Kitchen Timer	11
To Excessive Microwave Energy	3	More / Less	12
Grounding Instructions	3	SENSOR QUICK TOUCH	
Important Safety Instructions	4	OPERATION INSTRUCTION	12
INFORMATION	5~8	Sensor Popcorn	13
Specifications	5	Sensor Reheat	13
Control Panel	5	Sensor Reheat Chart	13
Names of Oven Parts And Accessories.....	6	Quick Touch Cook	14
Installation	6	Quick Touch Cook Chart	14
Microwave Utensil Guide	7	Auto Weight Defrost	15
Special Techniques For Microwave Cooking .	8	COOKING	16~18
Cleaning	8	TROUBLE SHOOTING	19~21
OPERATION	9~15	Questions And Answers	19
Clock	9	Before Calling For Service	21
Quick On	9	ESPAÑOL	22~33
Timed Cooking	9		
User Choice	10		
2 Stage Timed Cooking	11		

WARRANTY

FULL ONE YEAR WARRANTY ON MICROWAVE OVEN

For one year from the date of purchase, if this Kenmore microwave oven fails due to a defect in material or workmanship, Sears will repair it free of charge.

FULL FIVE YEAR WARRANTY ON THE MAGNETRON

For five years from the date of purchase, of the magnetron in this Kenmore microwave oven fails due to a defect in material or workmanship, Sears will repair it free of charge.

WARRANTY SERVICE IS AVAILABLE BY SIMPLY CONTACTING THE NEAREST SEARS STORE OR SERVICE CENTER IN THE UNITED STATES.

This warranty applies only while this product is in use in the united states.

This warranty gives you specific legal rights, and you may also have other right which vary from state to state.

Sears, Roebuck and Co., D/ 817WA, Hoffman Estates, IL. 60179 U.S.A.

SAFETY

SAFETY

PRECAUTIONS TO AVOID POSSIBLE EXPOSURE TO EXCESSIVE MICROWAVE ENERGY ...

- f ⚠ **Do not attempt to operate this oven with the door open**, since open-door operation can result in harmful exposure to microwave energy. It is important not to defeat or tamper with the safety interlock.
- f ⚠ **Do not operate the oven if it is damaged.** It is particularly important that the oven door close properly and that there is no damage to the:
 - door (bent)
 - hinges and latches (broken or loosened)
 - door seals and sealing surfaces.
- f ⚠ **Do not place any object between the oven front face and the door**, or allow soil or cleaner residue to accumulate on sealing surfaces.
- f ⚠ **The oven should not be adjusted or repaired** by anyone except properly qualified service personnel.

GROUNDING INSTRUCTIONS

This appliance must be grounded! If an electrical short circuit occurs, grounding reduces the risk of electric shock by providing an escape wire for the electric current. This appliance is equipped with a cord having a grounding wire with a grounding plug.

Put the plug into an outlet that is properly installed and grounded.

⚠ WARNING ⚠

If you use the grounding plug improperly, you risk electric shock.

Ask a qualified electrician or the Sears Service Department if you do not understand the grounding instructions or if you wonder whether the appliance is properly grounded.

This appliance has a short power supply cord to reduce the risk of anyone's tripping over or becoming entangled in the cord. You may use an extension cord if you are careful.

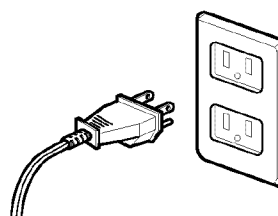

Three-Pronged (Grounding) Plug

If you use an extension cord, be sure that:

- f ⚠ the extension cord has the same electrical rating as the appliance.
- f ⚠ the marked rating of the extension cord shall be equal to or greater than the electrical rating of the appliance.
- f ⚠ the extension cord is a grounding-type 3-wire cord.
- f ⚠ the extension cord does not drape over a countertop or tabletop, where it can be pulled on by children or tripped over accidentally.
- f ⚠ the electrical cord is dry and not pinched or crushed in any way.

NOTE: This oven draws 13 amperes at on 120 Volts, 60 Hz.

SAFETY

Important Safety Instructions

The safety instructions below will tell you how to use your oven to avoid harm to yourself or damage to your oven.

WARNING - To reduce the risk of burns, electric shock, fire, injury to persons, or exposure to excessive microwave energy:

1. **Read all the instructions before using your oven.**
2. **Do not allow children to use this oven without close supervision!**
3. Read and follow the specific **PRECAUTIONS TO AVOID POSSIBLE EXPOSURE TO EXCESSIVE MICROWAVE ENERGY** found on page 3.
4. **Do not tamper with the built - in safety switches on the oven door!** The oven has several built-in safety switches to make sure the power is off when the door is open.
5. **When cleaning the door and the surfaces that touch the door, use only mild, nonabrasive soaps or detergents and a sponge or soft cloth.**
6. **If your oven is dropped or damaged,** have it thoroughly checked by a qualified service technician before using it again.
7. **To avoid a fire hazard:**
 - a) **Do not severely overcook foods.** It can cause a fire in the oven.
 - b) **Do not use recycled paper products in your oven.** They can contain particles that can cause arcing or may ignite.
 - c) **Do not overcook potatoes.** Overcooking could cause a fire.
 - d) **Do not store combustible items** (bread, cookies, etc.) **in the oven,** because if lightning strikes the power lines, it may cause the oven to turn ON.
 - e) **Do not use wire twist-ties in the oven.** Be sure to remove them before placing the item in the oven.
 - f) **Do not use the cavity for storage purposes.** Do not leave paper products, cooking utensils, or food in the cavity when not in use.
8. **If a fire should start:**
 - a) **Keep the oven door closed.**
 - b) **Turn the oven off.**
 - c) **Disconnect the power cord or shut off the power at the fuse or circuit breaker panel.**
9. Do not use this oven for commercial purposes. This microwave is made for household use only.
10. Install or locate this appliance in accordance with the provided installation instructions.
11. **To avoid electric shock:**
 - a) **This appliance must be grounded!** Connect it only to a properly grounded outlet. (See the **Grounding instructions** on page 3.)
 - b) **Do not operate this appliance if it has a damaged cord or plug,** if it is not working properly, or if it has been damaged or dropped.
 - c) **Do not immerse the electrical cord or plug in water.**
 - d) **Keep the cord away from heated surfaces.**
 - e) This appliance should be serviced only by qualified service personnel.
12. **To avoid improperly cooking some foods:**
 - a) **Do not heat any types of baby bottles or baby food.** Uneven heating may occur and possibly cause personal injury.
 - b) **Do not heat small-necked containers,** such as syrup bottles.
 - c) **Do not deep-fat fry in your microwave oven.**
 - d) **Do not attempt home canning in your microwave oven.**
 - e) Do not heat whole eggs in the shell, water with oil or fat, and sealed containers or closed glass jars. These items may explode.
13. Keep the glass tray and the turntable roller rest in the oven when you are cooking.
14. Do not use the oven outdoors. Do not store the oven outdoors. Do not use this product near water.
15. Do not cover or block any openings in the oven.
16. Do not run the microwave oven empty.
17. Do not let the cord hang over the edge of a table or counter.
18. Do not heat glass turntable excessively.
 - Do not cook bacon directly on the glass turntable.
 - Do not allow the grey film on special microwave cooking packages to touch the glass turntable. Put the package on a microwave-safe dish.
 - Keep a browning dish at least 3/16 inch above the glass turntable. If you use the browning dish incorrectly, you could break the glass turntable.
19. Be careful not to chip or scratch the edges of the turntable. Chips or scratches may cause the turntable to break during use.

SAVE THESE INSTRUCTIONS!

INFORMATION

SPECIFICATIONS

Power Supply	120 V AC, 60 Hz
Rated Power Consumption	1500 W
Microwave Output	*1000 W
Rated Current	13 A
Overall Dimensions(WxHxD)	20 ⁷ / ₈ " x 12 ³ / ₈ " x 15 ¹ / ₂ "
Oven Cavity Dimensions(WxHxD)	13 ³ / ₄ " x 8 ³ / ₄ " x 14 ⁵ / ₈ "
Effective Capacity of Oven Cavity	1.0 Cu.ft.

f uEC 705 RATING STANDARD

Specifications subject to change without prior notice.

CONTROL PANEL

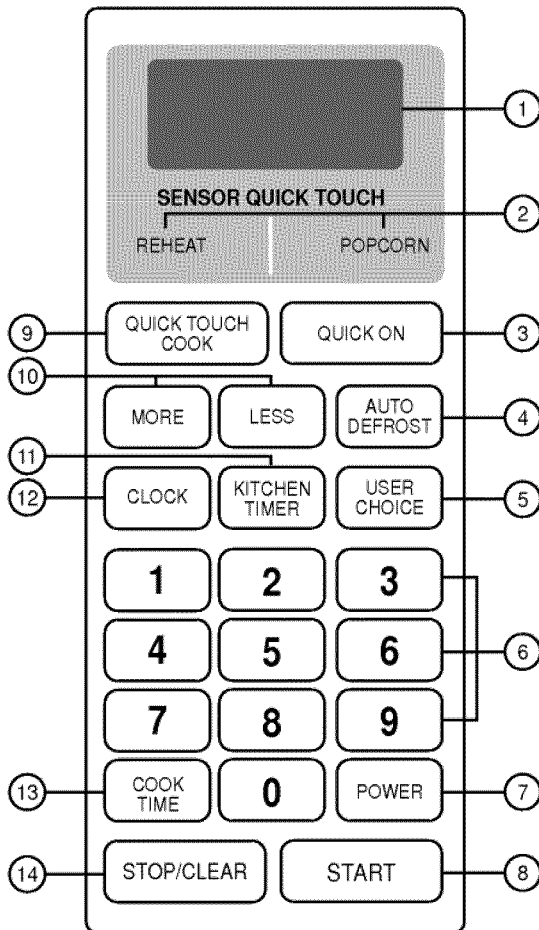

- 1. DISPLAY:** The Display includes a clock and indicators to tell you time of day, cooking time settings and cooking functions selected.
- 2. SENSOR QUICK TOUCH:** The oven's sensor will tell the oven how long to cook depending on the amount of humidity it detects from the quantity of the food in the oven.
- 3. QUICK ON:** Touch this pad to cook from 1 to 9 minutes automatically at 100% power.
- 4. AUTO DEFROST:** Meat, poultry, fish. Touch on pad to select food type and defrost food by weight.
- 5. USER CHOICE:** Touch this pad to change the oven's default settings for sound, clock, scroll speed, Lbs/Kg choice.
- 6. NUMBER:** Touch number pads to enter cooking time, power level, quantities, or weights.
- 7. POWER:** Touch this pad to select a cooking power level.
- 8. START:** Touch this pad to start a function. If you open the door after oven begins to cook, retouch START.
- 9. QUICK TOUCH COOK:** Touch this pad to select programming food items.
- 10. MORE/LESS:** Touch this pad to adjust cook food for a longer or shorter time.
- 11. KITCHEN TIMER:** Use the timer of your oven.
- 12. CLOCK:** Touch this pad to enter the time of day.
- 13. COOK TIME:** Touch this pad to set a cooking time.
- 14. STOP/CLEAR:** Touch this pad to stop the oven or clear all entries.

INFORMATION

NAMES OF OVEN PARTS AND ACCESSORIES

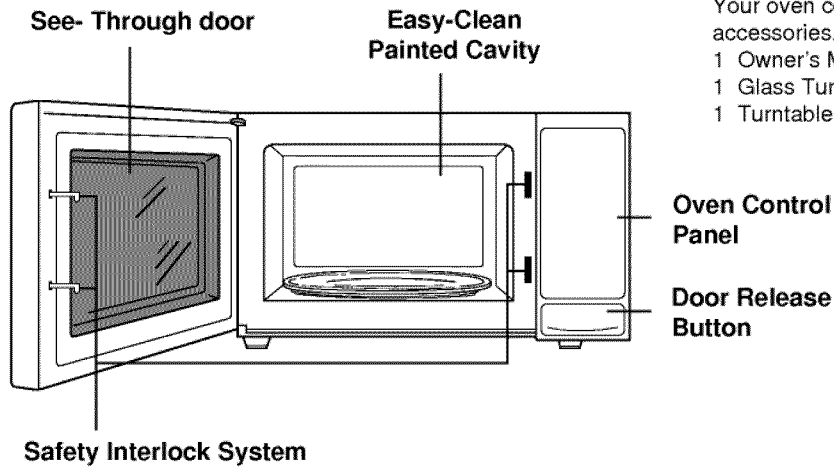

Glass Turntable

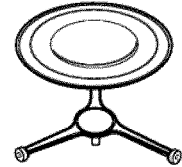

Turntable Roller Rest

INSTALLATION

1. Remove your Kenmore microwave oven and all packing materials from the shipping carton.
2. Place the oven on a level surface that provides at least 4 inches of space at the left, right, top, and rear sides for proper ventilation.

NOTE: Do not install your oven over a range, cooktop, or other heat-producing appliance. This oven is not designed for built-in use.

3. Place the turntable roller rest in the circle on the oven floor and then place the glass turntable on the top of the turntable roller rest.

NOTE: Never place the glass turntable in the oven upside down. Blocking the inlet and/or outlet openings can damage the oven.

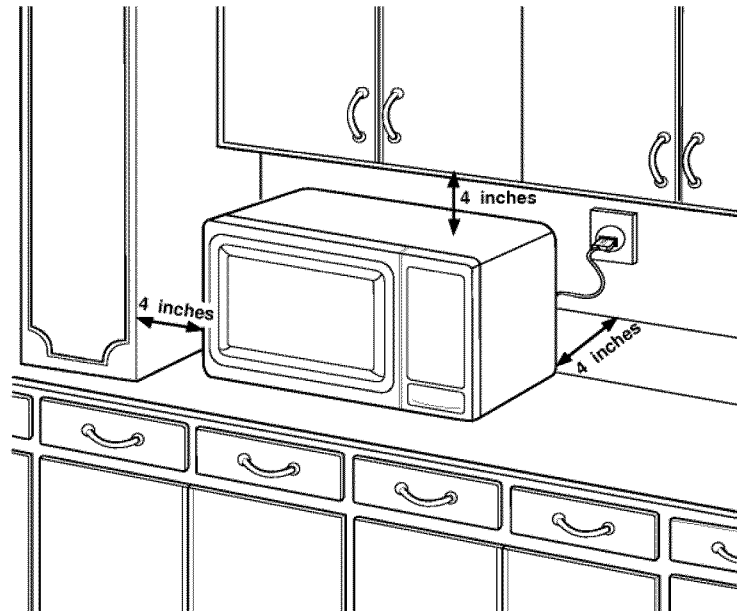

INFORMATION

MICROWAVE UTENSIL GUIDE

USE	DO NOT USE
<p>Ovenproof Glass (Glass which has been treated for high intensity heat): Utility dishes, bread dishes, pie plates, cake plates, liquid measuring cups, casseroles, and bowls without metallic trim.</p> <p>China: Bowls, cups, serving plates, and platters without metallic trim.</p> <p>Plastic: When plastic wrap is used as a cover, make sure that the dish is deep enough so the plastic wrap does not touch the food. As the food heats, it may melt the plastic wrap wherever the wrap touches the food. Place the wrap loosely over the top of the dish and secure it by pressing the wrap to the sides of the dish. Make a vent by lightly turning back one corner of the plastic wrap. This will allow excess steam to escape. Use plastic dishes, cups, semi-rigid freezer containers, and plastic bags only for short time cooking. Use these with care because the plastic may soften from the heat of the food.</p> <p>Paper: Paper towels, waxed paper, paper napkins, and paper plates with no metallic trim or design. Look at the manufacturer's label for use of paper products in the microwave oven.</p>	<p>Metal Utensil: Metal shields the food from microwave energy and produces uneven cooking. Also avoid metal skewers, thermometers, or foil trays. Metal utensils can cause arcing, which is a luminous discharge of electric current. Arcing can damage your microwave oven.</p> <p>Metal Decoration: Metal-trimmed or metal-banded dinnerware, casserole dishes, etc.</p> <p>Centura tableware: The Corning Company recommends you DO NOT USE Centura tableware or some Corelle closed-handle cups for microwave cooking.</p> <p>Aluminum Foil: Avoid large sheets of aluminum foil because they hinder cooking and may cause harmful arcing. Use small pieces of foil to shield poultry legs and wings. Keep ALL aluminum foil at least 1 inch from the side walls and door of the oven.</p> <p>Wood: Wooden bowls and boards will dry out and may split or crack when you use them in the microwave oven. Baskets react in the same way.</p> <p>Tightly Closed Containers or pouches: Be sure to leave an opening for steam to escape from covered utensils. Tightly closed utensils can explode.</p> <p>Brown Paper: Avoid using brown paper bags. They absorb too much heat and could burn.</p> <p>Metal Twist Ties: Remove metal twist ties from plastic or paper bags. They become hot and can cause a fire.</p>

Utensil Test: Place the empty utensil in the microwave oven.
Measure 1 cup of water in a glass measuring cup and place it in the oven beside the utensil.
Microwave on Hi Power for 1 minute.
If the utensil is warm to touch at the end of this time, you should not use it for microwave cooking.

INFORMATION

SPECIAL TECHNIQUES FOR MICROWAVE COOKING

Browning: Meat and poultry with high fat content cooked 10 or 15 minutes or longer will brown lightly. If you want to achieve an appealing brown color for foods cooked a shorter time, you may brush the meat with a browning agent, such as Worcestershire sauce, soy sauce, or barbecue sauce.

Covering: If you cover the food, you will trap heat and steam and the food will cook more quickly. Use a lid or plastic wrap with one corner folded back to vent the excess steam. Remember that the lids on glass casseroles can become hot during cooking, so handle them carefully. Waxed paper can prevent the food from splattering in the oven and will help retain heat. Waxed paper, napkins, or paper towels are good coverings to use when warming bread items. To absorb extra moisture, wrap sandwiches and fatty foods in paper towels.

Spacing: Individual foods, such as baked potatoes, cupcakes, and hors d'oeuvres will cook more evenly if you place them in a circular pattern at least an inch apart.

Stirring: Stirring the food blends the flavors and redistributes the heat in foods. Always stir from the outside toward the center of the dish, because the food at the outside of the dish heats first.

Turning Over: Large sized foods, such as roasts and whole poultry, should be turned over so that the top and bottom cook evenly. Also turn over chicken pieces and chops.

Arrangement: Do not stack the food, but arrange in a single layer in the dish for more even cooking. Because dense foods cook more slowly, place thicker portions of meat, poultry, fish, and vegetables toward the outer edge of the baking dish.

Testing for Doneness: Because foods cook quickly in a microwave oven, you need to test frequently for doneness. Follow the recipes included in this manual for more specific information.

Standing Time: Food often needs to stand from 2 to 15 minutes after you remove it from the oven. Usually, you need to cover food during standing time to retain heat. Remove most foods when they are slightly undercooked and they will finish cooking during standing time. The internal temperature of food will rise about 10 °F during standing time.

Shielding: To prevent some portions of rectangular or square dishes from overcooking, you may need to shield them with small strips of aluminum foil to block the microwaves. You can also cover poultry legs and wing tips with foil to keep them from overcooking. **Always keep foil at least 1 inch from oven walls** to prevent arcing.

Piercing: To prevent them from bursting, pierce the shell, skin, or membrane of foods before cooking. Foods that require piercing include: yolks and whites of eggs, hot dogs, clams, oysters, and whole vegetables, such as potatoes and squash.

CLEANING

Wipe the oven inside and outside with a soft cloth and a mild detergent solution. Then rinse and wipe dry. This should be done weekly or more often, if needed. Never use cleaning powders or rough pads.

Excessive oil splatters on the inside top will be difficult to remove if left for many days. Wipe splatters with a wet paper towel, especially after cooking chicken or bacon.

REMOVABLE PARTS

The turntable and turntable roller rest are removable. They should be washed in warm (not hot) water with a mild detergent and a soft cloth. Once they are clean, rinse well and dry with a soft cloth. Never use cleaning powders, steel wool, or rough pads.

⚠ The turntable may be cleaned at the sink. Be careful not to chip or scratch the edges as this may cause the turntable to break during use.

⚠ The turntable roller rest should be cleaned regularly.

SPECIAL CARE

For best performance and safety, the inner door panel and the oven front frame should be free of food or grease buildup. Wipe them often with a mild detergent. Then rinse and wipe dry. Never use cleaning powders or rough pads.

After cleaning the control panel, touch STOP/CLEAR to clear any entries that might have been entered accidentally while cleaning the panel.

OPERATION

CLOCK

This is a 12 hour clock.

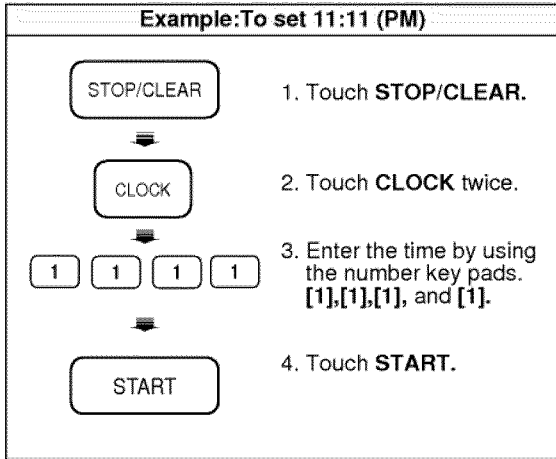

NOTE:

You can select AM and PM by touching the **CLOCK** pad once or twice.

QUICK ON

The **QUICK ON** feature allows you to cook for up to 9 minutes at HI power.

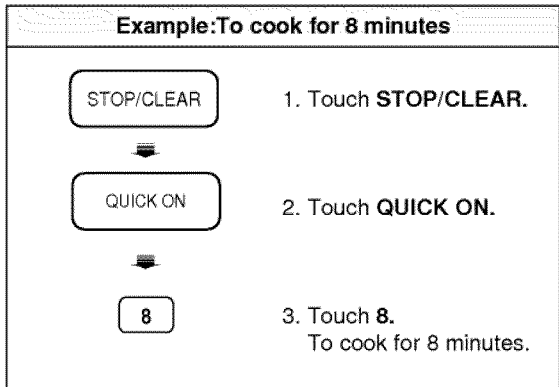

TIMED COOKING

This function allows you to cook food for a desired time. In order to give you the best results, there are 10 power level settings in addition to HI-POWER because many food need slower cooking (at less than HI-POWER).

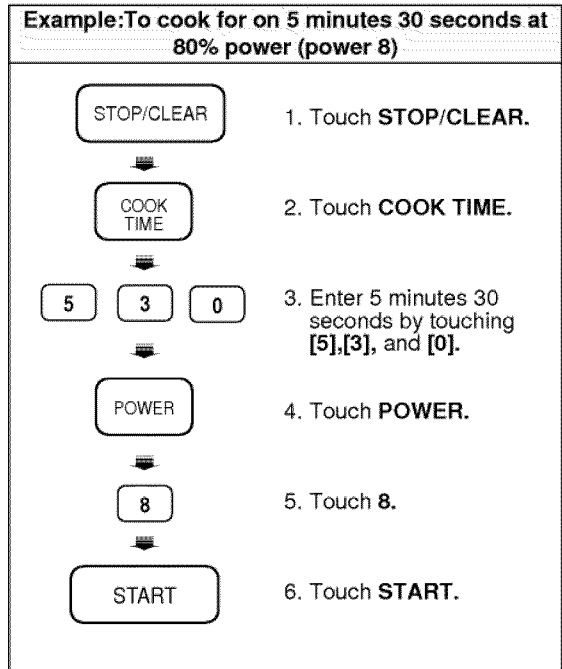

When cooking is complete, two short tones and one long tone will sound. The word **END** shows in the display window. Then the oven shuts itself off.

NOTE :

If you do not select the power level, the oven will operate at power HIGH. To set HI-POWER cooking, skip steps 4 & 5 above.

OPERATION

USER CHOICE

USER CHOICE provides four modes which make using your microwave oven quite handy. You can select SOUND ON/OFF, CLOCK ON/OFF, SCROLL SPEED, LBS/KG CHOICE.

Example: To turn off Sound of beeper

1. Touch **STOP/CLEAR**.

2. Touch **USER CHOICE**.

Four modes show in the display repeatedly. You can set them according to your intention.

3. Touch **1**.

4. Touch **2**.

NOTE: To turn beep sound back on, repeat steps 1 - 3, then touch number 1.

Example: To select kg unit

1. Touch **STOP/CLEAR**.

2. Touch **USER CHOICE**.

Four modes show in the display repeatedly. You can set them according to your preference.

3. Touch **4**.

4. Touch **2**.

NOTE: To select LBS, repeat steps 1 - 3, then touch number 1.

USER CHOICE FUNCTION CHART

NUMBER	USER CHOICE	NUMBER	RESULT
1	SOUND ON / OFF	1	Sound On
		2	Sound Off
2	CLOCK ON / OFF	1	Clock On
		2	Clock Off
3	SCROLL SPEED	1	Slow speed
		2	Normal speed
		3	Fast speed
4	LBS / KG	1	Lbs
		2	Kg

NOTE: When the power cord is first plugged in, the default settings are Sound ON, Clock ON, Normal Speed, LBS.

OPERATION

2 STAGE TIMED COOKING

For Two Stage cooking, repeat timed cooking steps 2 through 5 on the previous page before touching the START pad for additional Time and Power program you want to add. Auto Weight Defrost can be programmed before the first stage to defrost first and then cook.

MICROWAVE POWER LEVELS

Your microwave oven is equipped with ten power levels to give you maximum flexibility and control over cooking. The table below will give you some idea of which foods are prepared at each of the various power levels.

The chart below shows the power level settings for your oven.

MICROWAVE POWER LEVEL CHART

Power Level	Use
10 (High)	*Boiling water. *Making candy. *Cooking poultry pieces, fish, & vegetables. *Cooking tender cuts of meat. *Whole poultry.
9	*Reheating rice, pasta, & vegetables.
8	*Reheating prepared foods quickly. *Reheating sandwiches.
7	*Cooking egg, milk and cheese dishes. *Cooking cakes, breads. *Melting chocolate.
6	*Cooking veal. *Cooking whole fish. *Cooking puddings and custard.
5	*Cooking ham, whole poultry, lamb. *Cooking rib roast, sirloin tip.
4	*Thawing meat, poultry and seafood.
3	*Cooking less tender cuts of meat. *Cooking pork chops, roast.
2	*Taking chill out of fruit. *Softening butter.
1	*Keeping casseroles and main dishes warm. *Softening butter and cream cheese.
0	* Standing time. * Independent.

CHILD LOCK

This is a unique safety feature that prevents unwanted oven operation such as used by children. Once the CHILD LOCK is set, no cooking can take place.

To set the child lock

START

1. Touch and hold **START** until **LOCKED** appears in the display and two beeps are heard. If the time of day was already set, the time of day will return to the display window. After you touch another cooking pad.

If the CHILD LOCK was already set and you touched another cooking pad, **LOCKED** shows in the display. Then you can cancel the CHILD LOCK according to the procedure below.

To cancel the child lock

START

1. Touch and hold **START** pad until **LOCKED** disappears in the display.

After the CHILD LOCK is turned off, the time of day will return to the display window. The oven will operate normally.

KITCHEN TIMER

You can use the Timer of your oven for other purposes other than food cooking.

To set 3 minutes

STOP/CLEAR

1. The **STOP/CLEAR**.

↓

KITCHEN
TIMER

2. Touch **KITCHEN TIMER**.

↓

3

0

0

3. Touch **3, 0, and 0**.

↓

START

4. Touch **START**.

OPERATION

MORE/LESS

By using the MORE or LESS keys, all of ONE TOUCH COOK and the TIMED COOK program can be adjusted to cook food for a longer or shorter time. Pressing MORE will add 10 seconds to the cooking time each time you press it. Pressing LESS will subtract 10 seconds of cooking time each time you press it.

To adjust the QUICK TOUCH COOK (ex. Beverage 2 cups) cooking time for a longer time or a shorter time

-
1. Touch **STOP/CLEAR**.
2. Touch **QUICK TOUCH COOK**.
3. Touch **4**.
4. Touch **2**.

NOTE: Press the MORE or LESS pad during time countdown.

SENSOR QUICK TOUCH OPERATION INSTRUCTION

Sensor touch cooking provides exciting new features to make microwaving easier. Your new microwave oven will guide you, step by step, whether simply to reheat food. Sensor menu with all the popular food choices, helps you to reheat perfectly because it has been pre-programmed and can tell how long to reheat food items.

Categories:

**Sensor Reheat Menu
Sensor Popcorn**

For most Sensor Touch Cooking programs, a chart with specific food examples and cooking instructions is provided in the next few pages.

1. The Sensor Touch system works by detecting a build-up of vapor.
2. Make sure the door remains closed.
3. Once the vapor is detected, two beeps will sound.
4. Opening the door or touching the STOP/CLEAR pad before the vapor is detected will abort the process. The oven will stop.
5. Before using Sensor Touch, make sure the exterior of the reheating container and the interior of the oven are dry, to assure the best results.
6. Room temperature should not exceed 95 °F.
7. Oven should be plugged in at least 5 minutes before sensor the cooking.

OPERATION

SENSOR POPCORN

SENSOR POPCORN lets you pop commercially packaged microwave popcorn (1.75-3.5 ounces). For best results, use one fresh bag of popcorn.

Place only one bag of prepackaged microwave popcorn on the center of turntable.

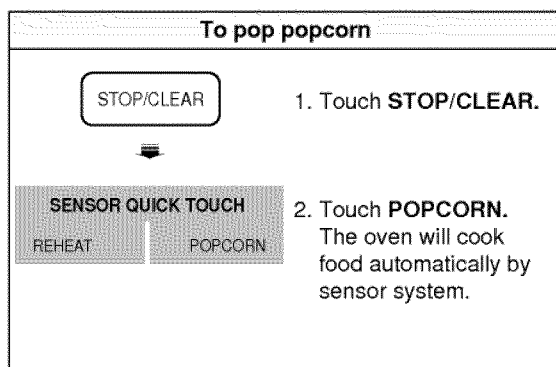

NOTE:

fU Do not attempt to reheat or cook any unpopped kernels.

fU If you use a microwave popper, test it on sensor. We had excellent results, but there are many such devices available and their results may vary. IN NO CASE should you use a popper that concentrates the microwave energy.

SENSOR REHEAT

This feature allows you to reheat precooked room-temperature or refrigerated foods without selecting cooking times and power levels. This feature has 3 categories : dinner plate, soup/sauce, casserole. See follow chart for more information.

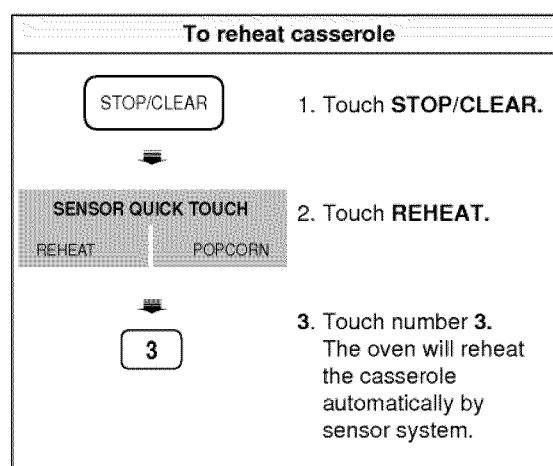

SENSOR REHEAT CHART

Code	Category	Direction	Amount
1	Dinner plate	Place foods to be heated on dinner plate or similar dish. Cover with plastic wrap.	Approx. 1/2-1 pound
2	Soup/Sauce	Place food to be heated in an appropriately sized microwave container. Cover with plastic wrap.	1-4 cups
3	Casserole	Cover dish containing the casserole with plastic wrap.	2-6 servings

OPERATION

QUICK TOUCH COOK

This feature allows to cook foods that you select by touching QUICK TOUCH COOK pad. It has 6 foods categories. See follow chart for more information.

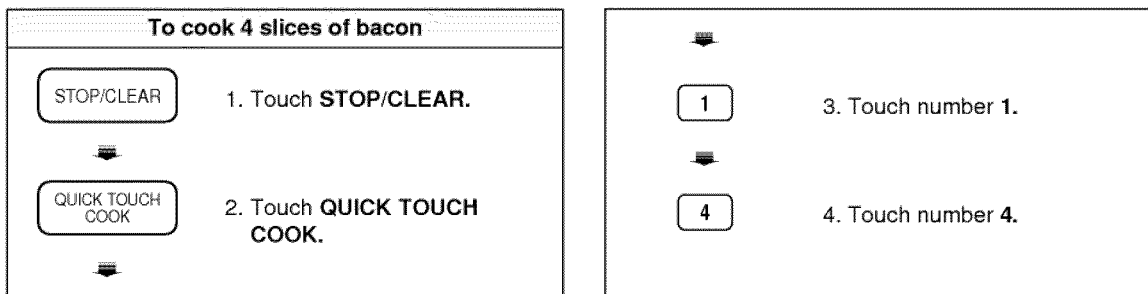

QUICK TOUCH COOK CHART

First, touch QUICK TOUCH COOK pad, then select food and amount.

Code	Category	Direction	Amount
1	Bacon	Place bacon strips on microwave bacon rack for best results. (Use diner plate lined with paper towels if rack is not available).	2-6 slices
2	Frozen Roll/ Muffin	Remove from display package and place on plate. (If muffins are over 3 oz. each, count as two when entering quantity.)	1-6 pieces (2-3 ounces each)
3	Fresh Roll/ Muffin	Remove from display package and place on plate. (If muffins are over 3 oz. each, count as two when entering quantity.)	1-6 pieces (2-3 ounces each)
4	Beverage	Remove from display package and place on plate. (Be careful!! The beverage will be very hot! Sometimes liquids heated in cylindrical containers will splash out when the cup is moved.)	1-2 cups
5	Chicken Pieces	Place the chicken pieces in an appropriately sized microwaveable container, cover with plastic wrap, and vent.	0.5-2.0 lbs.
6	Hot Cereal	Prepare as directed on package and cook. Stir and allow standing time before eating. Use only instant hot cereal.	1-6 servings

If you open the door or press STOP during cooking, the process will be canceled.

OPERATION

AUTO WEIGHT DEFROST

Three defrost sequences are preset in the oven. The defrost feature provides you with the best defrosting method for frozen foods. The cooking guide will show you which defrost sequence is recommended for the food you are defrosting.

With the Auto Weight Defrost feature, the oven automatically sets the defrosting time and power levels for you.

The oven automatically determines required defrosting times for each food item according to the weight you enter.

For added convenience, the Auto Weight Defrost includes a built-in beep mechanism that reminds you to check, turn over, separate, or rearrange. Three different defrosting levels are provided.

- 1 MEAT**
- 2 POULTRY**
- 3 FISH**

f You can select the category by touching the numeric key 1 (MEAT), numeric key 2 (POULTRY), and numeric key 3 (FISH) after touching the AUTO DEFROST pad.

f Available weight is 0.1~6.0 lbs.

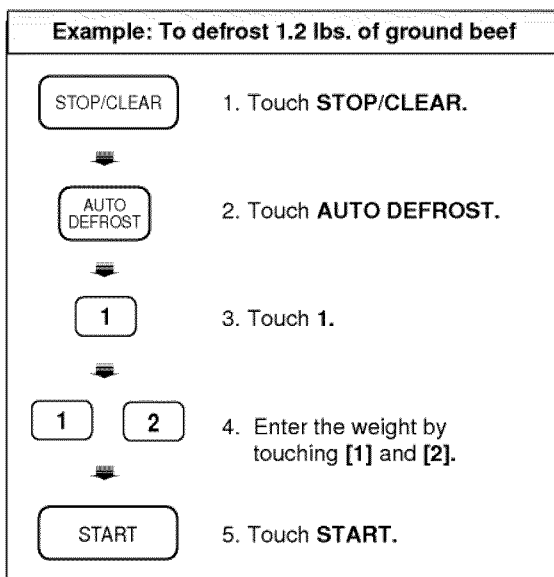

NOTE:

When you touch the START pad, the display changes to defrost time count down. The oven will beep twice during the DEFROST cycle. At each beep, open the door and turn, separate, or rearrange the food. Remove any portions that have thawed. Return frozen portions to the oven and touch START to resume the defrost cycle.

f For best results, remove fish, shellfish, meat, and poultry from its original closed paper or plastic package (wrapper). Otherwise, the wrap will hold steam and juice close to the foods, which can cause the outer surface of the foods to cook.

f For best results, shape your ground meat into the form of a doughnut before freezing. When defrosting, scrape off thawed meat when the beep sounds and continue defrosting.

f Place foods in a shallow container or on a microwave roasting rack to catch drippings.

f Food should still be somewhat icy in the center when removed from the oven.

AUTO WEIGHT DEFROST SEQUENCE LIST

Sequence	Food
1 MEAT	BEEF Ground beef, Round steak, Cubes for stew, Tenderloin steak, Pot roast, Rib roast, Rump roast, Chuck roast, Hamburger patty.
	LAMB Chops (1 inch thick), Rolled roast
	PORK Chops (1/2 inch thick), Hot dogs, Spareribs, Country-style ribs, Rolled roast, Sausage.
	VEAL Cutlets (1 lb., 1/2 inch thick)
2 POULTRY	POULTRY Whole (under 4 lbs.), Cut-up, Breasts (boneless)
	CORNISH HENS Whole
	TURKEY Breast
3 FISH	FISH Fillets, Whole Steaks SHELLFISH Crab meat, Lobster tails, Shrimp, Scallops

COOKING

Vegetables

Vegetable Medley, serves 4 as a side dish or 2 as a meal

2 large carrots, cut into 1-inch pieces
1 large baking potato, diced
1 medium red onion, thinly sliced
4 cloves of garlic, peeled
2 stalks celery, cut into 1-inch pieces
2 tablespoons olive oil
salt and pepper to taste

Place everything in a 2-quart microwave dish, cover and cook with **sensor** or microwave on high power for about 10 minutes or until the carrots are tender.

Stewed Peppers, serves 4

1 large red bell pepper, cored and cut into 1-inch strips
1 large green bell pepper, cored and cut into 1-inch strips
1 medium red onion, thinly sliced
2 cloves garlic, smashed
1 cup prepared salsa
2 tablespoons olive oil
salt and pepper to taste

Place everything in a 2 quart microwave dish, cover and cook with **sensor** or microwave on high power for about 12 minutes or until the peppers are very soft.

Rice

Spanish Rice, serves 4

1/2 pound lean ground beef or smoked sausage
1 medium green bell pepper, cored and chopped
1 small yellow onion, chopped
1 cup instant rice
1 can (14 ounces) stewed tomatoes
1 teaspoon chili powder

Place the meat, pepper, and onion in a 2-quart microwave dish and microwave 2 minutes on high power. Drain off the fat. Stir in the other ingredients, cover and cook on **sensor**.

Casserole

Macaroni and Cheese, serves 4

4 ounces macaroni noodles, cooked as directed on package
1 cup shredded cheddar cheese
1 large egg
2/3 cup milk
2 ounces canned, diced pimentos
salt, pepper to taste
cayenne pepper to taste, optional

Mix the egg with the milk and blend with the other ingredients in a 2 quart microwave dish. Cover and cook on **sensor**.

Ground Beef and Noodle Casserole, serves 4

5 ounces egg noodles, cooked according to package directions
1 pound lean ground beef, cooked and drained
2 cups cooked chopped broccoli, either fresh OR 10 ounces cooked peas
1 can (10 3/4 ounces) cheddar cheese soup salt and pepper to taste
2 ounces canned pimentos, optional

Mix everything in a 2 quart casserole, cover and cook on **sensor**.

Shepherd's Pie, serves 4

1 pound ground beef, lamb or turkey, cooked and drained
1 package frozen, cut green beans, defrosted or equal amount of cooked green beans
1 can, (10 ounces) condensed cream of mushroom soup
2 cups instant mashed potatoes prepared as directed on package or equal amount of leftover mashed potatoes
4 tablespoons butter melted
salt and pepper to taste

Spread the beans over the bottom of a 1 1/2-quart microwave dish. Mix the meat with the soup and season with salt and pepper. Spread this mixture over the beans and spread the potatoes over the meat. Drizzle the butter over the top of the casserole and cook on **sensor** or microwave on medium power for about 8 minutes or to an internal temperature of 180 degrees.

Chicken and Spaghetti Casserole, serves 2

2 boneless chicken breasts, cooked and diced
1 pound spaghetti or other noodles of choice, cooked as directed on package
1 can (14 ounces) creamed corn
1 can (14 ounce) stewed tomatoes
1 cup frozen peas, defrosted
1 cup shredded mozzarella cheese

Mix the first 5 ingredients in a 2 quart microwave dish and spread the cheese over the top. Cover and cook on **sensor** or microwave on medium power for 10 minutes or to an internal temperature of 180 degrees.

Fish, Seafood

Poached Salmon, serves 4

1/2 cup dry white wine
1/2 cup bottled clam juice
4 sprigs fresh dill weed or 1 tablespoon dried dill weed
6 pepper corns
4 small salmon steaks, about 4 ounces each lemon slices

In a shallow 2-quart microwave dish place the first 5 ingredients, cover and microwave on high power 3 minutes. Add the salmon, cover again, and cook on **sensor** or microwave on high power for 3-4 minutes or until the cooked and the internal temperature is about 160 degrees.

COOKING

Peel and Eat Shrimp, serves 2

1/2 cup dry white wine
2 cloves garlic, minced
2 tablespoons lemon juice
4 tablespoons butter
1 pound large shrimp in shells

Place everything in a 2-quart microwave dish push to the edge of the dish, cover and cook on **sensor** or microwave on high power for about 5 minutes, stirring once or until the shrimp are pink. Peel the shrimp and serve with juices.

Rolled Fish Filets, serves 4

4 fish filets, sole, flounder, catfish or roughy about 4 ounces each
lemon pepper
2 tablespoons lemon juice

Season the fish with lemon pepper and roll up and secure with a wooden pick. Place in a glass pie plate and sprinkle with lemon juice. Cover with plastic wrap and cook on **sensor** or microwave on medium power for about 5 minutes or until the fish is opaque and flakes easily. Mix the juices with 1/4 cup Italian salad dressing and pour over the fish.

Fish Filets Parmesan, serves 4

4 fish filets (about 4 ounces each) folded over
1 cup prepared spaghetti sauce
1/2 cup Parmesan cheese, grated

Place the sauce in a 2 quart microwave dish and lay the fish over with the thicker part toward the side of the dish. Sprinkle with cheese. Cover and cook on **sensor**.

Trout Almandine, serves 2

2 whole trout, about 8 ounces each
2 tablespoons slivered almonds
2 tablespoons lemon juice
4 slices bacon, cooked crisp and crumbled
4 tablespoons chopped parsley

Place the fish along side each other head to tail in a 10 inch glass pie plate. Add the lemon juice and butter, and cover with plastic wrap and cook on **sensor** or microwave on medium power for about 6 minutes or until the fish is done. Place on a serving platter and pour cooking juices over the fish and sprinkle with nuts, bacon, and parsley.

Eggs

Hard Cooked Eggs for Egg Salad -

If you've ever made an egg salad the traditional way you know it's quite a task. You have to boil the eggs, allow them to cool and then peel them before you chop them and add the other ingredients. When you cook the eggs as directed here, the job is so much easier but the recipe looks and tastes the same.

Put 1/4 cup hot water and carefully crack eggs in a 4-cup measuring cup or 1-quart casserole dish. Gently pierce the yolks with a fork. Cover with vented plastic wrap and cook on **sensor**. ALLOW STANDING TIME OF 1 MINUTE OR UNTIL THE EGGS HAVE SET.

Puff Omelet or Egg Cake -

This is one the easiest ways to cook eggs by microwave. Though it doesn't look like a conventional omelet, it tastes great and is so much easier to make.

Beat eggs and milk (1 TS per 1 egg) until blended in a 4-cup measuring cup or 1-2 quart microwave casserole dish. Cover with vented plastic wrap and cook on **sensor**. ALLOW STANDING TIME OF 1 MINUTE.

Scrambled Eggs -

Cook as puff omelet but scramble immediately after cooking.

Ham and Egg for One -

This recipe is done before the toast pops out of the toaster and there's no frying pan to wash.

Place a slice of boiled ham in an 8-ounce coffee cup and crack a large egg into the ham cup. Cover with plastic wrap and cook on **sensor**. ALLOW STANDING TIME OF 1 MINUTE OR UNTIL THE EGGS HAVE SET.

COOKING

EZ Eggs and Sausage for Two -

This is a great recipe for busy people who have to get off to work without a lot of breakfast preparation.

4 cooked breakfast sausage links
4 eggs, beaten
2 scallions, thinly sliced
salt and pepper to taste

Coat a 10-inch glass pie with vegetable oil spray and place the sausages around the edge of the plate. Pour the eggs into the plate and cover with plastic wrap and cook on **sensor**. ALLOW STANDING TIME OF 1 MINUTE OR UNTIL THE EGG HAVE SET.

Chicken

Chicken in Yogurt, serves 2

2 large chicken breasts, cut-up and skinned
3 tablespoons butter or margarine
3 tablespoons gravy flour
1 cup chicken stock
1 cup yogurt
1/2 teaspoon dried thyme leaves
salt and pepper to taste

Mix everything in a 2 quart microwave dish, cover and cook on microwave on high power for about 15 minutes or until the chicken is 170 degrees.

Breast of Chicken Florentine, serves 2

1 10 ounce package frozen spinach, cooked and squeezed of water
2 skinned and boned chicken breasts, cut in half
1/2 pound white mushrooms, sliced
1/2 cup grated Parmesan cheese
1/4 cup bread crumbs
1 tablespoon lemon juice
chopped parsley

Lay the spinach on the bottom of a shallow casserole dish or glass pie. Lay the chicken breasts over the spinach and top with the mushrooms. Mix the cheese and crumbs and sprinkle over the mushrooms. Drizzle lemon juice over the top and cover with plastic wrap. Cook using microwave on high power for 10 minutes or until the chicken is 170

degrees. Sprinkle with parsley and serve.

Meatless Dishes

Potato Onion Bake, serves 2

2 medium baking potatoes, cubed
1 large yellow onion, diced
2 tablespoons olive oil
salt and pepper to taste

Place everything in a 2 quart microwave dish, cover and cook on microwave on high power for 10 minutes or until the potatoes are tender.

Beans and Rice, serves 4 as a side dish or 2 as a meal

1/2 cup long grain rice
1 1/2 cup tomato or V8 juice
1 can (14 ounce)pinto beans, drained
1 tablespoons dried onion flakes
salt and pepper to taste

Place everything in a 2-quart microwave dish, cover and cook on microwave on high power for 15 minutes or until the potatoes are tender.

TROUBLE SHOOTING

QUESTIONS AND ANSWERS

Operation

Question	Answer
What is wrong when the oven light will not glow during cooking?	There may be several reasons why the oven light will not glow. Perhaps: <ul style="list-style-type: none"> ƒ ∅ Cooking time has not been set. ƒ ∅ START has not been touched. ƒ ∅ The light bulb is burned out.
Why does steam come out of the air exhaust vent?	Steam is normally produced during cooking. The microwave oven has been designed to vent this steam.
Will the microwave oven be damaged if it operates empty?	Yes. Never operate the oven empty or without the glass turntable.
Does microwave energy pass through the viewing screen in the door?	No. The metal screen bounces the energy back to the oven cavity. The holes (or ports) only allow light to pass through. They do not let microwave energy pass through.
Why does the beep sound when a pad on the control panel is touched?	The beep tells you that the setting is properly entered.
Can my microwave oven be damaged if food is cooked for too long?	Like any other cooking appliance, it is possible to overcook food to the point where the food creates smoke and even possibly fire damage to the inside of the oven. It is always best to be near the oven while it is in the cooking process.
When the oven is plugged into wall outlet for the first time, it might not work properly. What is wrong?	The microcomputer controlling your oven may temporarily become scrambled and fail to function as programmed when you plug in for the first time or when power resumes after a power interruption. Unplug the oven from the 120 volt household outlet and then plug it back in to reset the microcomputer.
Why do I see light reflection around the outer case?	This light is from the oven light which is located between the oven cavity and the outer wall of the oven.
What are the various sounds I hear when the microwave oven is operating?	The clicking sound is caused by a mechanical switch turning the microwave oven's magnetron ON and OFF. The heavy hum and clunk is from the change in power the magnetron draws as it is turned ON and OFF by a mechanical switch. The change in blower speed is from the change in line voltage caused by the magnetron being turned ON and OFF.

TROUBLE SHOOTING

QUESTIONS AND ANSWERS (CONTINUED)

Food

Question	Answer
What is wrong when baked foods have a hard, dry, brown spot?	A hard, dry, brown spot indicates overcooking. Shorten the cooking or reheating time.
Why do eggs sometimes pop?	When baking, frying, or poaching eggs, the yolk may pop due to steam build-up inside the yolk membrane. To prevent this, simply pierce the yolk with a wooden pick before cooking. CAUTION: Never microwave eggs in the shell.
Why are scrambled eggs sometimes a little dry after cooking?	Eggs dry out if they are overcooked even if the same recipe is used each time. The cooking time may need to be varied for one of these reasons: f ∅ Eggs vary in size. f ∅ Eggs are at room temperature one time and at refrigerator temperature another time. f ∅ Eggs continue cooking during standing time.
Is it possible to pop popcorn in a microwave oven?	Yes, if using one of the two methods described below: (1) Microwave-popping devices designed specifically for microwave cooking. (2) Prepackaged commercial microwave popcorn that contains specific times and power output needed for an acceptable final product. Follow exact directions given by each manufacturer for its popcorn popping product and do not leave the oven unattended while the corn is being popped. If corn fails to pop after the suggested time, discontinue cooking. Overcooking could result in an oven fire. CAUTION: f ∅ Never use a brown paper bag for popping corn or attempt to pop leftover kernels. f ∅ Do not pop prepackaged commercial microwave popcorn directly on the glass turntable. To avoid excessive heating of the glass turntable, position the popcorn bag on a plate.
Why do baked apples sometimes burst during cooking?	The peel has not been removed from the top half of each apple to allow for expansion of the interior of the apple during cooking. As in conventional cooking methods, the interior of the apple expands during the cooking process.
Why do baked potatoes sometimes burn during cooking?	If the cooking time is too long, fire could result. At the end of the recommended cooking time, potatoes should be slightly firm. CAUTION: Do not overcook.
Why is a standing time recommended after microwave cooking time is over?	Standing time allows foods to continue cooking evenly for a few minutes after the actual microwave oven cooking cycle. The amount of standing time depends upon the density of the foods.
Why is additional time required for cooking food stored in the refrigerator?	As in conventional cooking, the initial temperature of food affects total cooking time. You need more time to cook food taken out of a refrigerator than for food at room temperature.

TROUBLE SHOOTING

Before Calling For Service

You can often correct operating problems yourself. If your microwave oven fails to work properly, locate the operating problem in the list below and try the solutions listed for each problem.

If the microwave oven still does not work properly, contact the nearest Sears Service Center. Sears Service Centers are fully equipped to handle your service requirements.

Problem	Possible Causes
Oven does not start	<ul style="list-style-type: none"> f U Is the power cord plugged in? f U Is the door closed? f U Is the cooking time set?
Arcing or Sparking	<ul style="list-style-type: none"> f U Are you using approved cookware? f U Is the oven empty?
Incorrect Time of Day	<ul style="list-style-type: none"> f U Have you tried to reset the Time of Day?
Unevenly Cooked Foods	<ul style="list-style-type: none"> f U Are you using approved cookware? f U Is the glass turntable in the oven? f U Did you turn or stir the food while it was cooking? f U Were the foods completely defrosted? f U Was the time/cooking power level correct?
Overcooked Foods	<ul style="list-style-type: none"> f U Was the time/cooking power level correct?
Undercooked Foods	<ul style="list-style-type: none"> f U Are you using approved cookware? f U Were the foods completely defrosted? f U Was the time/cooking power level correct? f U Are the ventilation ports clear?
Improper Defrosting	<ul style="list-style-type: none"> f U Are you using approved cookware? f U Was the time/cooking power level correct? f U Did you turn or stir the food during the defrosting cycle?

FEDERAL COMMUNICATIONS COMMISSION RADIO FREQUENCY INTERFERENCE STATEMENT (U.S.A. ONLY)

WARNING:

This equipment generates and uses ISM frequency energy and if not installed and used properly, that is in strict accordance with the manufacturer's instructions, may cause interference to radio and television reception. It has been type tested and found to comply with limits for ISM Equipment pursuant to part 18 of FCC Rules, which are designed to provide reasonable protection against such interference in a residential installation.

However, there is no guarantee that interference will not occur in a particular installation. If this equipment does cause interference to radio or television reception, which can be determined by turning the equipment off and on, the user is encouraged to try to correct the interference by one or more of the following:

- f U Reorient the receiving antenna of the radio or television.
- f U Relocate the Microwave Oven with respect to the receiver.
- f U Move the microwave oven away from the receiver.
- f U Plug the microwave oven into a different outlet so that the microwave oven and the receiver are on different branch circuits.

The manufacturer is not responsible for any radio or TV interference caused by **unauthorized modification** to this microwave oven. It is the responsibility of the user to correct such interference.