

This Owner's Manual is provided and hosted by [Appliance Factory Parts](#).



LG 65212 Owner's Manual

[Shop genuine replacement parts for LG 65212](#)



[Find Your LG Refrigerator Parts - Select From 834 Models](#)

----- Manual continues below -----



REFRIGERATOR SERVICE MANUAL

CAUTION
BEFORE SERVICING THE UNIT,
READ THE SAFETY PRECAUTIONS IN THIS MANUAL.

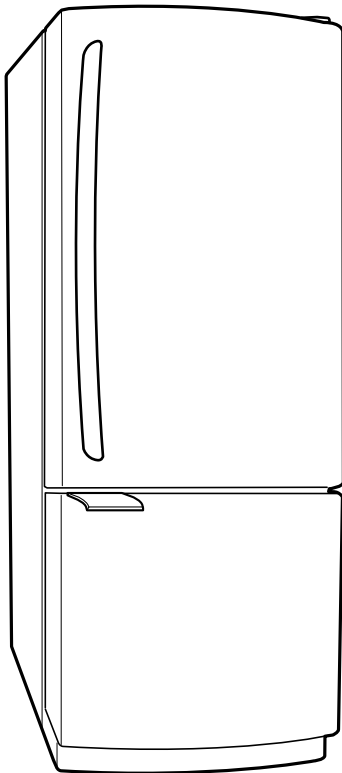

MODELS:

795.65002.402
795.65004.402
795.65009.402
795.65012.402
795.65014.402
795.65019.402

CONTENTS

SAFETY PRECAUTIONS	2
1. SPECIFICATIONS	3
2. PARTS IDENTIFICATION	4
3. DISASSEMBLY	6
4. ADJUSTMENT	8
5. CIRCUIT DIAGRAM	10
6. TROUBLESHOOTING	12
7. OPERATION PRINCIPLE AND REPAIR METHOD OF ICEMAKER	18
8. DESCRIPTION OF FUNCTION & CIRCUIT OF MICOM	22
9. EXPLODED VIEW & REPLACEMENT PARTS LIST	43

SAFETY PRECAUTIONS

Please read the following instructions before servicing your refrigerator.

1. Check the refrigerator for electrical faults.
2. To prevent electric shock, unplug before servicing.
3. Always check line voltage and amperage.
4. Use standard electrical components.
5. Don't touch metal products in the freezer with wet hands. This may cause frostbite or cause your skin to freeze and stick to the surfaces inside the freezer.
6. Prevent water from flowing onto electric elements in the mechanical parts.
7. Close the top door before opening the bottom door. Otherwise, you might hit your head when you stand up.
8. When tilting the refrigerator, remove any materials on the refrigerator, especially the glass shelves and stored foods.
9. When servicing the evaporator, wear cotton gloves. This is to prevent injuries from the sharp evaporator fins.
10. Disassembly, repair, and servicing the sealed refrigeration system should be performed only by qualified and certified personnel. Refrigerant should not be vented into the atmosphere; proper recovery equipment should be used.

1. SPECIFICATIONS

1-1 DISCONNECT POWER CORD BEFORE SERVICING IMPORTANT RECONNECT ALL GROUNDING DEVICES

All parts of this appliance capable of conducting electrical current are grounded. If grounding wires, screws, straps, clips, nuts or washers used to complete a path to ground are removed for service, they must be returned to their original position and properly fastened.

1-2 IMPORTANT NOTICE

This information is intended for use by individuals possessing adequate backgrounds of electrical, electronic and mechanical experience. Any attempt to repair a major appliance may result in personal injury and property damage. The manufacturer or seller cannot be responsible for the interpretation of this information, nor can it assume any liability in connection with its use.

1-3 ELECTRICAL SPECIFICATIONS

Temperature Control (Position : MID)..... 8-(-6)°F
 Defrost Control..... 7 hrs.
 Defrost Thermostat..... 50°F
 Electrical Rating :115V. AC, 60 Hz.....1-5 Amp.
 Maximum Current Leakage.....0.5 mA
 Maximum Ground Path Resistance..... 0.14 Ohms
 Energy Consumption..2 0 cu.ft : 482 kWh/yr(Energy star, 520kWh/yr
2 2 cu.ft : 494 kWh/yr(Energy star), 530kWh/yr

1-4 NO LOAD PERFORMANCE CONTROL POSITION: MID/MID

And Ambient of :.....70°F.....90°F
 Fresh Food, °F.....33°F to 41°F.....33°F to 41°F
 Frozen Food, °F..... (-4°F) to 4°F.....(-4°F) to 4°F
 Percent RunningTime25%-35%.....45%-60%

PERFORMANCE DATA (NORMAL OPERATING CONDITIONS)			
AMB	WATTS	SYSTEM PRESSURE (PSIG)	
		HIGH SIDE	LOW SIDE
70°F	98 (+10 / -10)	97 (+5 / -3)	(-5) to (-2)
90°F	98 (+10 / -10)	130 (+3 / -3)	(-4) to 1
110°F	103 (+5 / -5)	174 (+5 / -5)	(-2) to 3

1-5 REFRIGERATION SYSTEM

Minimum Compressor Capacity Vacuum21 in.
 Minimum Equalized Pressure
 @ 70°F49 PSIG
 @ 90°F 56 PSIG
 Refrigerant - R - 134a 4.05 oz.....(21cu.ft.....5.47oz)
 Compressor687 BTU/hr

1-6 INSTALLATION

Clearance must be provided at top, sides and rear of the refrigerator for air circulation.

AT TOP 1 in
 AT SIDES1/8 in
 AT REAR1 in

1-7 REPLACEMENT PARTS

Relay.....6749C-0008D
 Overload6750C-0004S
 Defrost Thermostat..... 6615JB2005C
 Defrost Heater..... 20cu. ft : 5300JB1001D
22cu. ft : 5300JB1100J
 Evaporator Fan Motor..... 4680JK1002B
 CapacitorOCZZJB2003H
 Compressor (Hi-Side)..... 2521JJ8007A
 Evaporator (Lo-Side)..... 20cu. ft : 5421JJ1001A
22cu. ft : 5421JJ1001B
 Condenser5403JJ1005A,4A
 Dryer5851JJ2002B
 Condenser Fan Motor4681JK1001B
 Temperature Control.....6871JB2047A,46B
 Main Control.....6871JB1215A,13A

1-8 AIR FLOW / CIRCULATION D' AIR

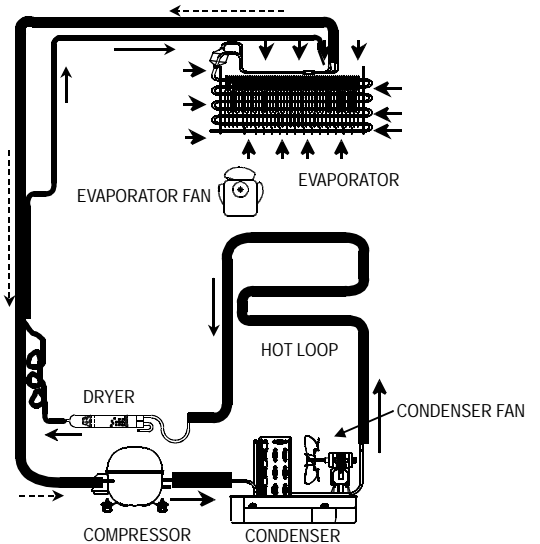

21 cu.ft..... 5.47 oz.

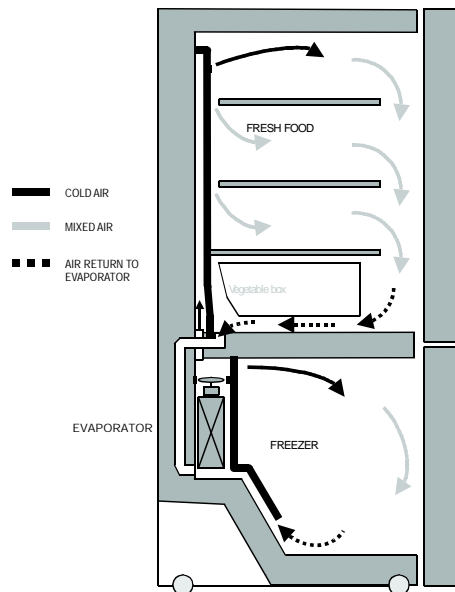

2. PARTS IDENTIFICATION

Freezer Drawer Model

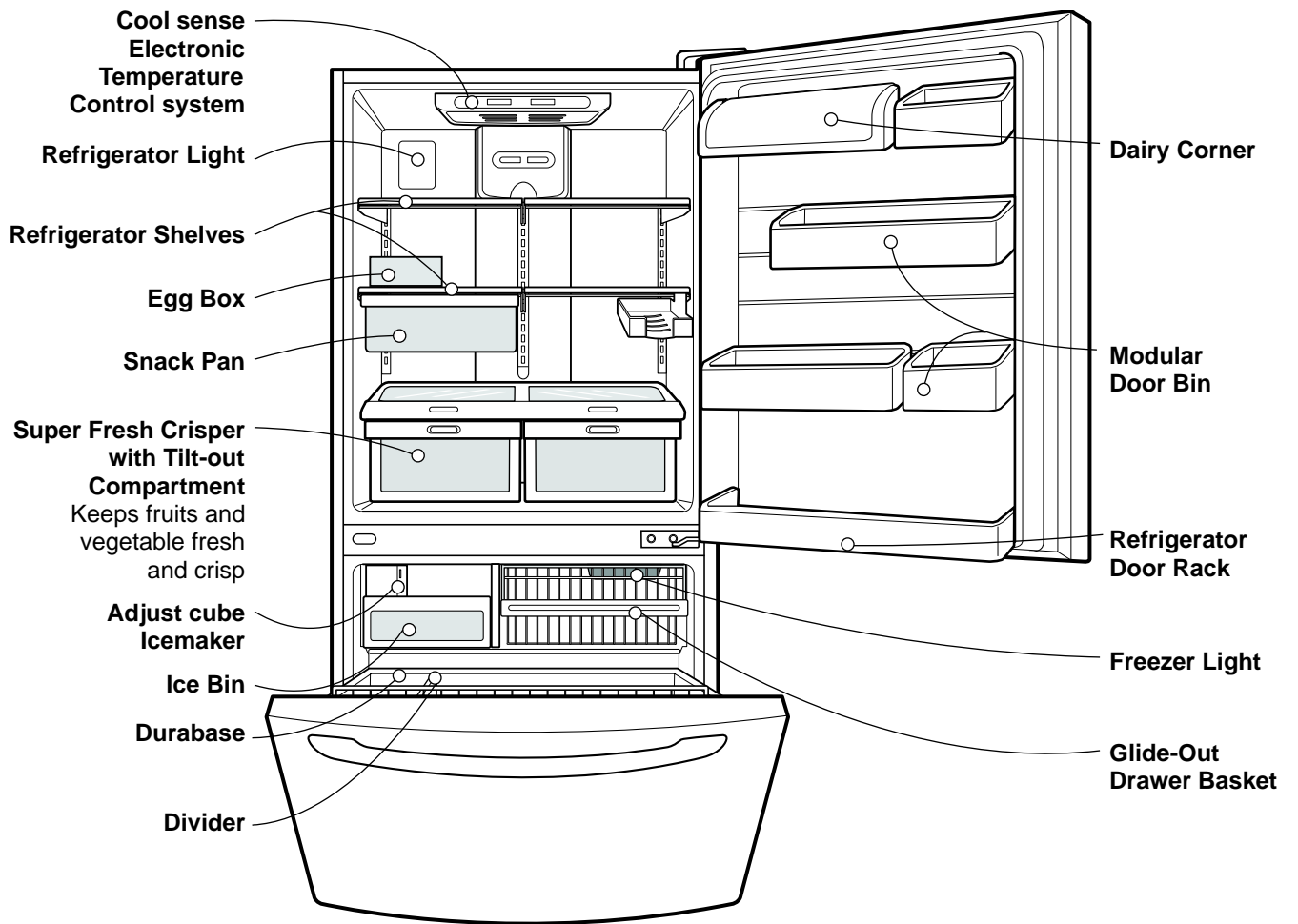

Swing Out Freezer Door Model



3. DISASSEMBLY

3-1 DOOR

Refrigerator Door

1. Remove the hinge cover by pulling it upwards.
2. Loosen the hexagonal bolts attaching the upper hinge to the body and lift the freezer door.

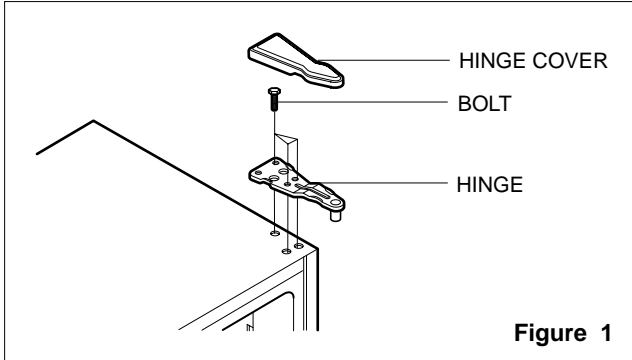

3. Pull out the door gasket to remove from the door foam assembly.

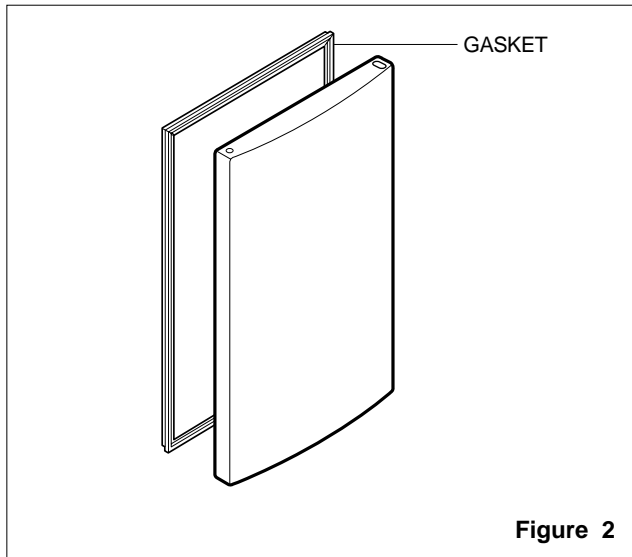

Freezer Door

1. Loosen the hexagonal bolts attaching the lower hinge to the body to remove the refrigerator door only.

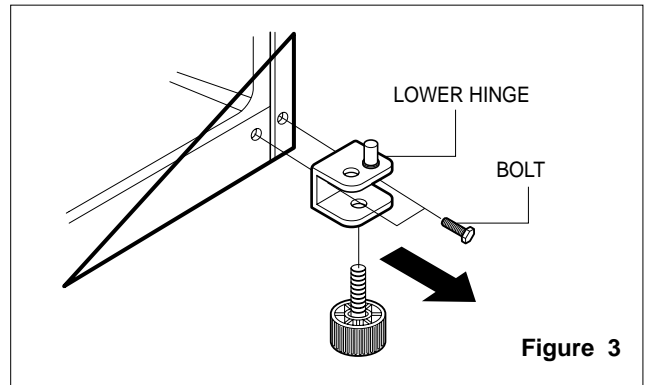

2. Pull out the door gasket to remove from the door foam assembly.

3-2 DOOR SWITCH

1. To remove the door switch, pry it out with a slotted-type driver, as shown in (Figure 4).
2. Disconnect the lead wire from the switch.

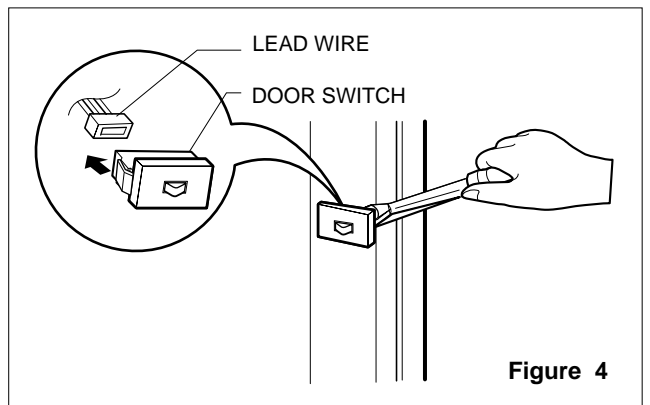

3-3 FAN AND FAN MOTOR

1. Remove the freezer shelf. (If your refrigerator has an icemaker, remove the icemaker first)
2. Remove the grille by pulling it out and by loosening a screw.
3. Remove the Fan Motor assembly by loosening 2 screws and disassemble the shroud.
4. Pull out the fan and separate the Fan Motor and Bracket.

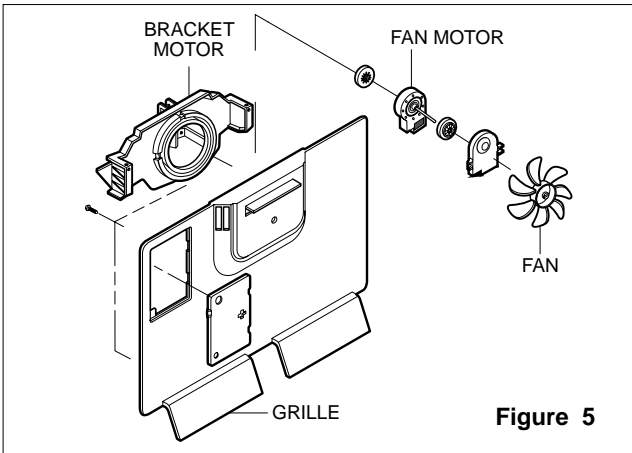

Figure 5

3-4 DEFROST CONTROL ASSEMBLY

Defrost Control assembly consists of Defrost Sensor and FUSE-M.

The Defrost Sensor works to defrost automatically. It is attached to the metal side of the Evaporator and senses its temperature. At 72°C, it turns the Defrost Heater off. Fuse-M is a safety device for preventing over-heating of the Heater when defrosting.

1. Pull out the grille assembly. (Figure 6)
2. Separate the connector with the Defrost Control assembly and replace the Defrost Control assembly after cutting the Tie Wrap. (Figure 7)

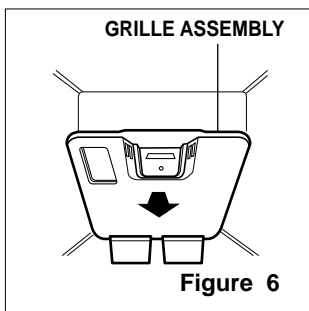

Figure 6

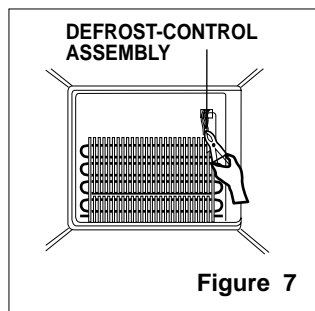

Figure 7

3-5 LAMP

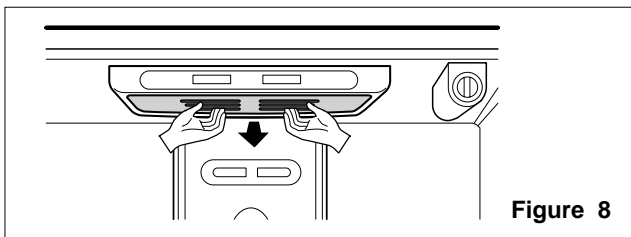

Figure 8

3-5-1 Refrigerator Compartment Lamp

1. Unplug the power cord from the outlet.
2. Remove refrigerator shelves.
3. Release the hooks on both ends of the lamp shield and pull the shield downward to remove it.
4. Turn the lamp counterclockwise.
5. Assemble in reverse order of disassembly. Replacement bulb must be the same specification as the original (Max. 60 W-2EA).

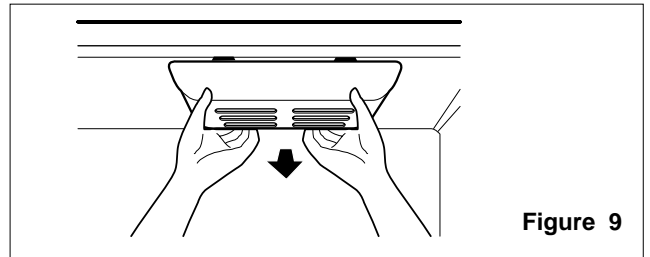

Figure 9

3-5-2 Freezer Compartment Lamp

1. Unplug refrigerator or disconnect power.
2. Reach behind light shield to remove bulb.
3. Replace bulb with a 40-watt appliance bulb.
4. Plug in refrigerator or reconnect power.

3-6 CONTROL BOX-REFRIGERATOR

1. First, remove all shelves in the refrigerator, then remove the Refrigerator control Box by loosening 2 screws.

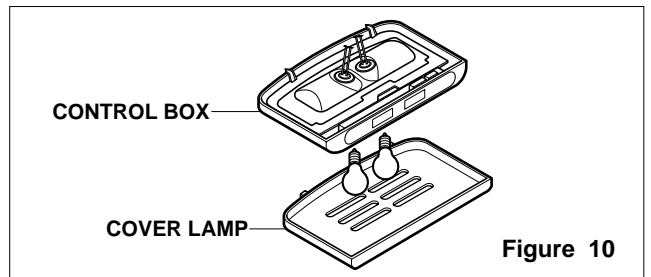

Figure 10

2. Remove the Refrigerator Control Box by pulling it downward.
3. Disconnect the lead wire on the right position and separate the lamp sockets.

3-7 MULTI DUCT

1. Remove an upper and lower Cap by using a flat screwdriver, and loosen 3 screws. (Figure 11)
2. Disconnect the lead wire on the bottom position.

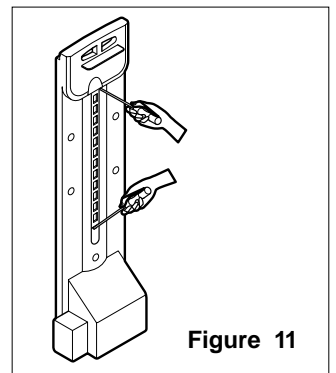

Figure 11

4. ADJUSTMENT

4-1 COMPRESSOR

4-1-1 Role

The compressor intakes low temperature and low pressure gas from the evaporator of the refrigerator and compresses this gas to high-temperature and high-pressure gas. It then delivers the gas to the condenser.

4-1-2 Composition

The compressor includes overload protection. The PTC starter and OLP (overload protector) are attached to the outside of the compressor. Since the compressor is manufactured to tolerances of 1 micron and is hermetically sealed in a dust and moisture-free environment, use extreme caution when repairing it.

4-1-3 Note for Usage

- (1) Be careful not to allow over-voltage and over-current.
- (2) If compressor is dropped or handled carelessly, poor operation and noise may result.
- (3) Use proper electric components appropriate to the Particular Compressor in your product.
- (4) Keep Compressor dry.
If the Compressor gets wet (in the rain or a damp environment) and rust forms in the pin of the Hermetic Terminal, poor operation and contact may result.
- (5) When replacing the Compressor, be careful that dust, humidity, and soldering flux don't contaminate the inside of the compressor. Dust, humidity, and solder flux contaminate the cylinder and may cause noise, improper operation or even cause it to lock up.

4-2 PTC.STARTER

4-2-1 Composition of PTC-Starter

- (1) PTC (Positive Temperature Coefficient) is a no-contact semiconductor starting device which uses ceramic material consisting of $BaTiO_3$.
- (2) The higher the temperature is, the higher the resistance value. These features are used as a starting device for the Motor.

4-2-2 Role of PTC-Starter

- (1) The PTC is attached to the Sealed Compressor and is used for starting the Motor
- (2) The compressor is a single-phase induction motor. During the starting operation, the PTC allows current flow to both the start winding and main winding

4-2-3 PTC-Applied Circuit Diagram Starting Method for the Motor

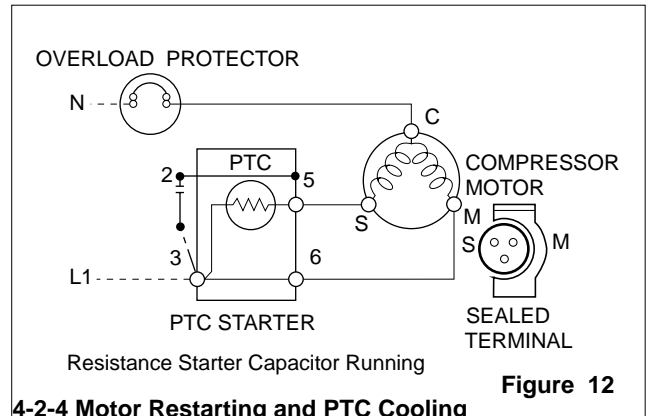

4-2-4 Motor Restarting and PTC Cooling

- (1) It requires approximately 5 minutes for the pressure to equalize before the compressor can restart.
- (2) The PTC device generates heat during operation. Therefore, it must be allowed to cool before the compressor can restart.

4-2-5 Relation of PTC-Starter and OLP

- (1) If the compressor attempts to restart before the PTC device is cooled, the PTC device will allow current to flow only to the main winding.
- (2) The OLP will open because of the over current condition. This same process will continue (3 to 5 times) when the compressor attempts to restart until the PTC device has cooled. The correct OLP must be properly attached to prevent damage to the compressor.
Parts may appear physically identical but could have different electrical ratings. Replace parts by part number and model number. Using an incorrect part could result in damage to the product, fire, injury, or possibly death.

4-2-6 Note for Using the PTC-Starter

- (1) Be careful not to allow over-voltage and over-current.
- (2) Do not drop or handle carelessly.
- (3) Keep away from any liquid.
If liquid such as oil or water enters the PTC, PTC materials may fail due to breakdown of their insulating capabilities.
- (4) If the exterior of the PTC is damaged, the resistance value may be altered. This can cause damage to the compressor and result in a no-start or hard-to-start condition.
- (5) Always use the PTC designed for the compressor and make sure it is properly attached to the compressor. Parts may appear physically identical but could have different electrical ratings. Replace parts by part number and model number. Using an incorrect part could result in damage to the product, fire, injury, or possibly death.

possibly death.

4-3 OLP (OVERLOAD PROTECTOR)

4-3-1 Definition of OLP

- (1) OLP (OVERLOAD PROTECTOR) is attached to the Compressor and protects the Motor by opening the circuit to the Motor if the temperature rises and activating the bimetal spring in the OLP.
- (2) When high current flows to the Compressor motor, the Bimetal works by heating the heater inside the OLP, and the OLP protects the Motor by cutting off the current flowing to the Compressor Motor.

4-3-2 Role of the OLP

- (1) The OLP is attached to the Sealed Compressor used for the Refrigerator. It prevents the Motor Coil from being started in the Compressor.
- (2) For normal operation of the OLP, do not turn the Adjust Screw of the OLP in any way.

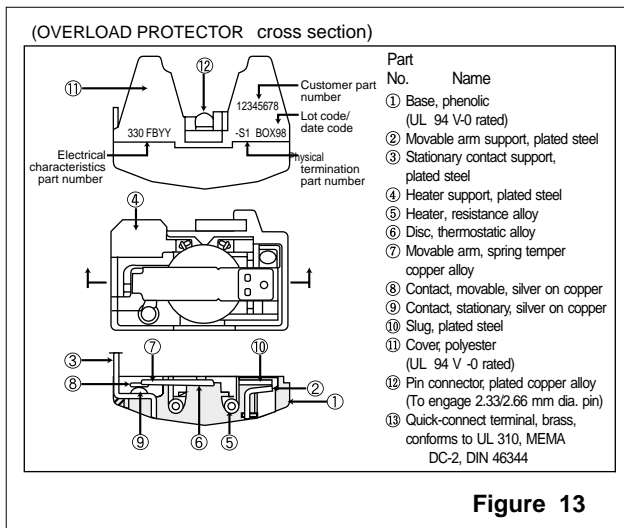

4-4 TO REMOVE THE COVER PTC

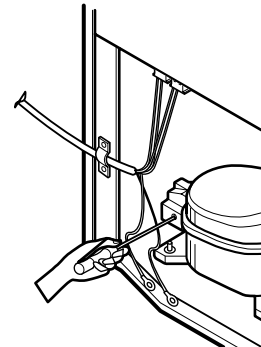

(1) Remove the Cover Back M/C.

(2) Remove the screw on Cover PTC

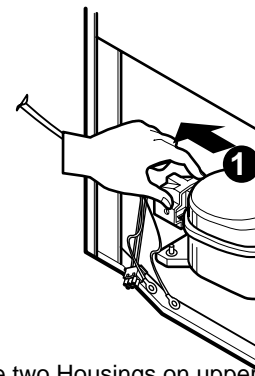

(3) Remove two Housings on upper part of Cover PTC.

(4) Take out the cover PTC from upper to lower position like 1 .

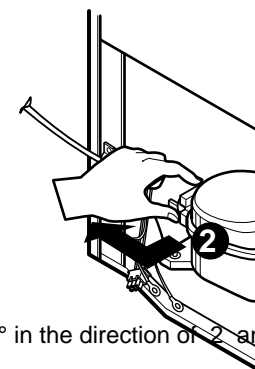

(5) Turn 45° in the direction of 2 and take it out.

(6) Assembly in reverse order of disassembly.

5. CIRCUIT DIAGRAM

DIAGRAMA ELECTRICO - CIRCUIT DIAGRAM

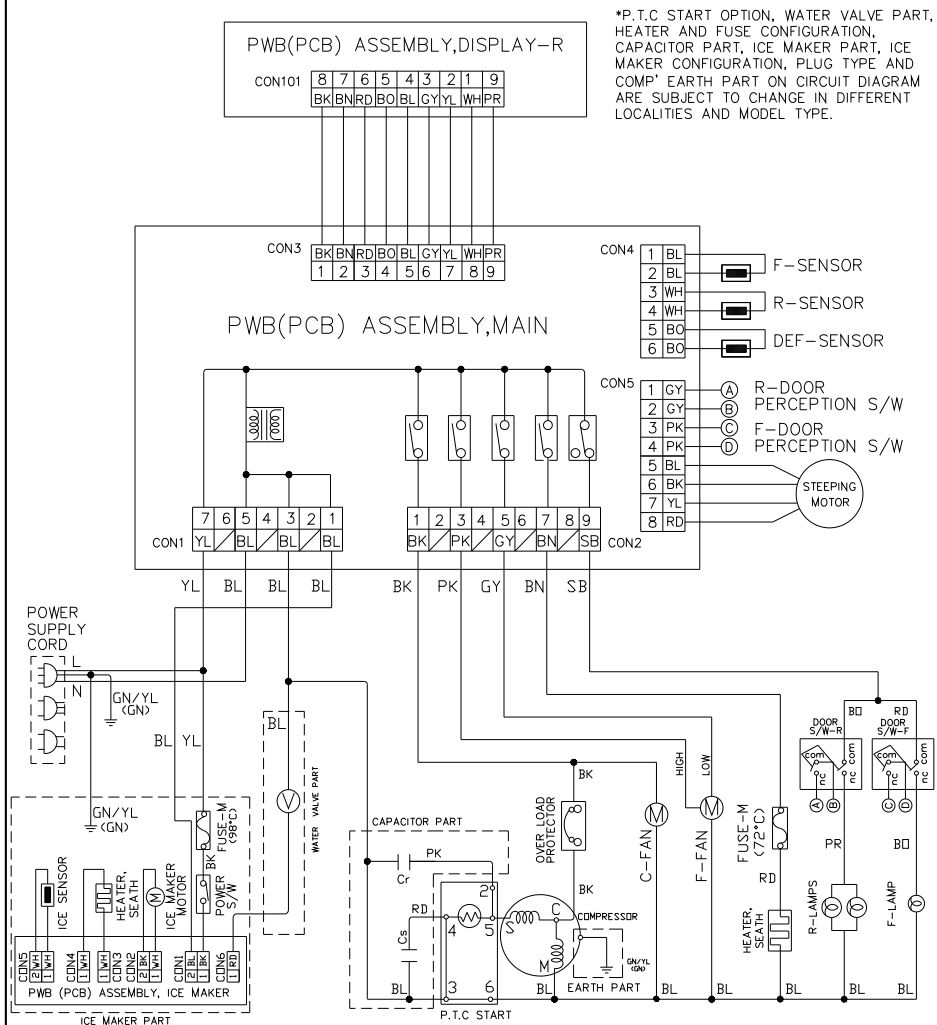

*P.T.C START OPTION, WATER VALVE PART, HEATER AND FUSE CONFIGURATION, CAPACITOR PART, ICE MAKER PART, ICE MAKER CONFIGURATION, PLUG TYPE AND COMP' EARTH PART ON CIRCUIT DIAGRAM ARE SUBJECT TO CHANGE IN DIFFERENT LOCALITIES AND MODEL TYPE.

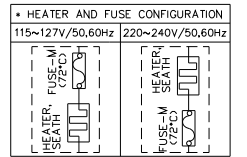
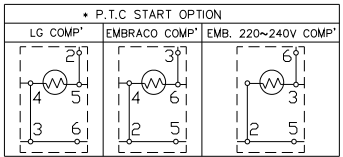
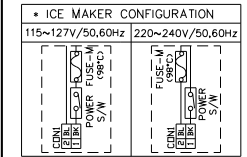

- BK: NEGRO/BLACK BN: CAFE/BROWN RD: ROJO/RED BO: NARANJA/BRIGHT ORANGE
- YL: AMARILLO/YELLOW GN: VERDE/GREEN BL: AZUL/BLUE PR: VIOLETA/PURPLE GY: GRIS/GRAY
- WH: BLANCO/WHITE SB: AZUL CIELO/SKY BLUE PK: ROSA/PINK

6. TROUBLESHOOTING

6-1 COMPRESSOR AND ELECTRIC COMPONENTS

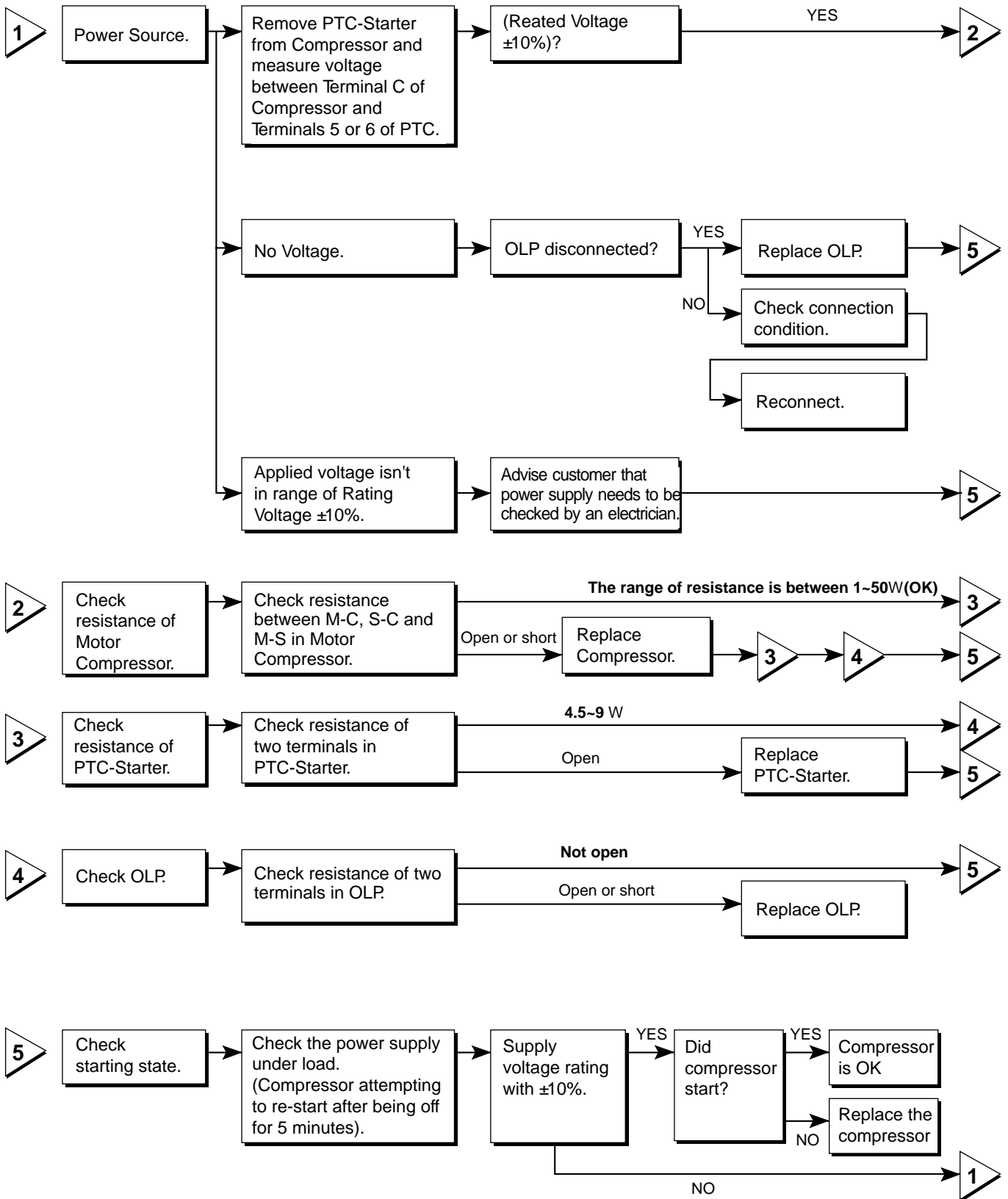

6-2 PTC AND OLP

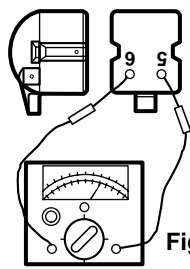
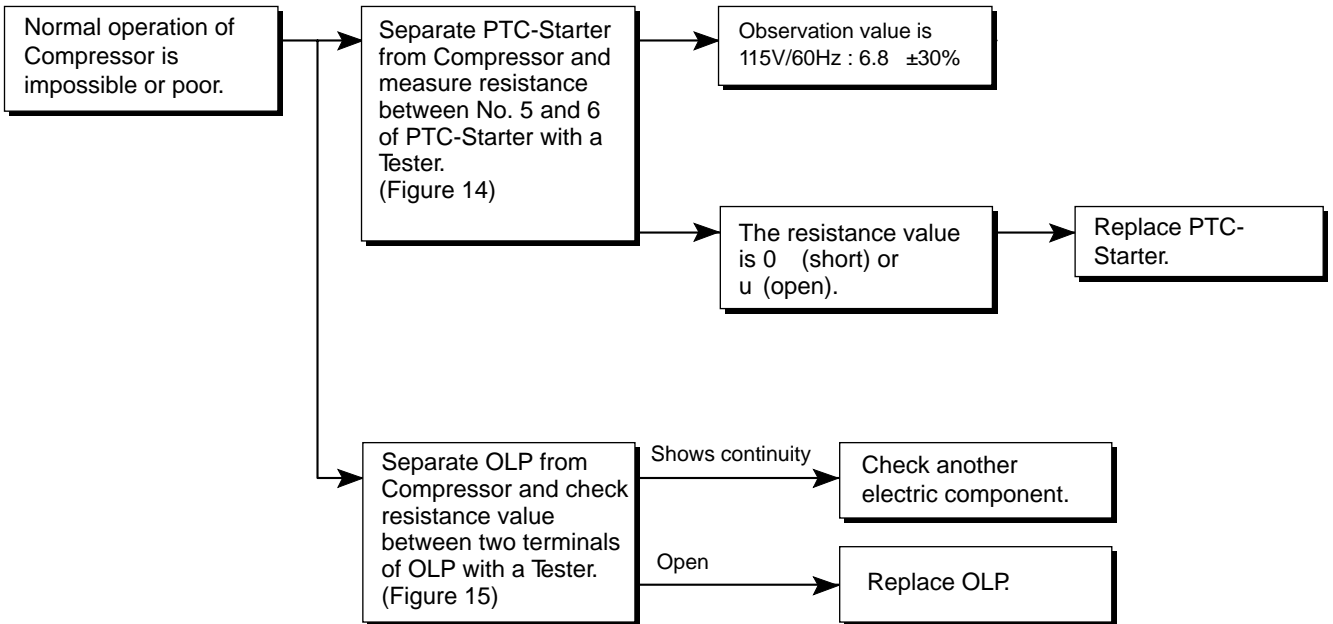

Figure 14

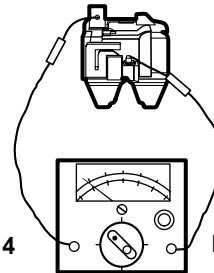
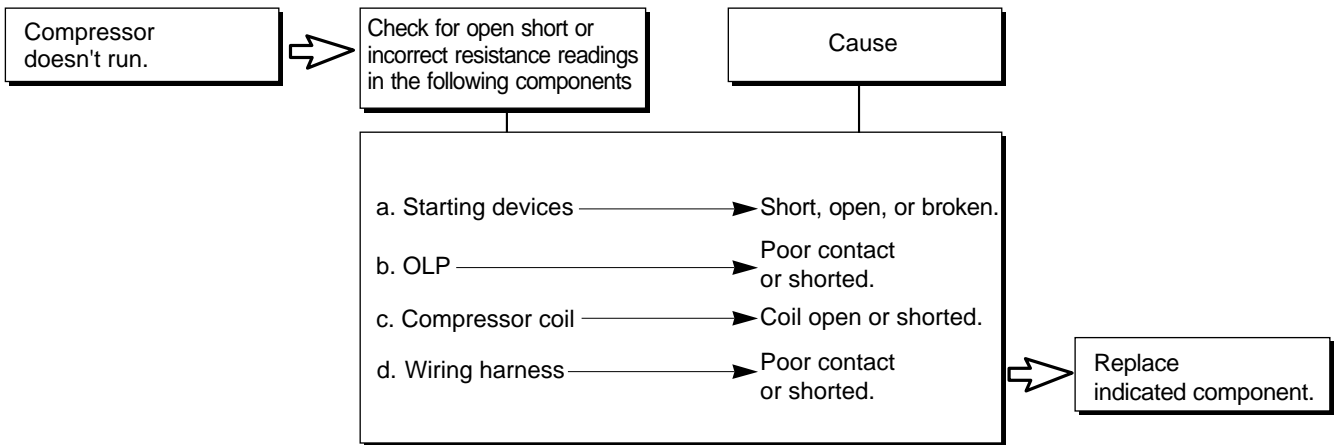

Figure 15

6-3 OTHER ELECTRICAL COMPONENTS

Not cooling at all



Poor cooling performance

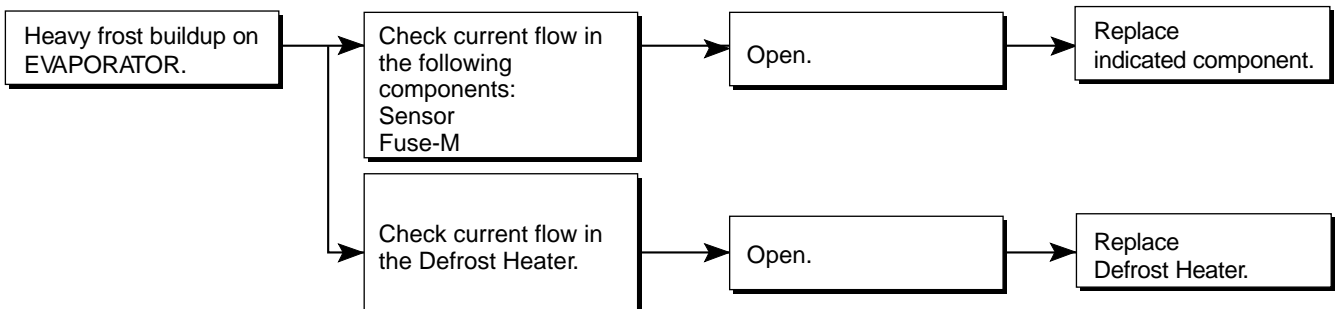
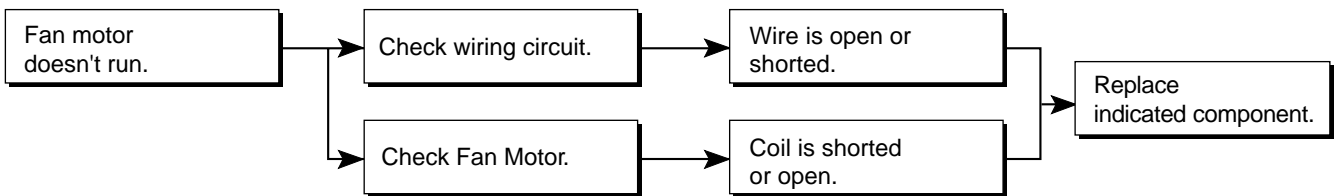
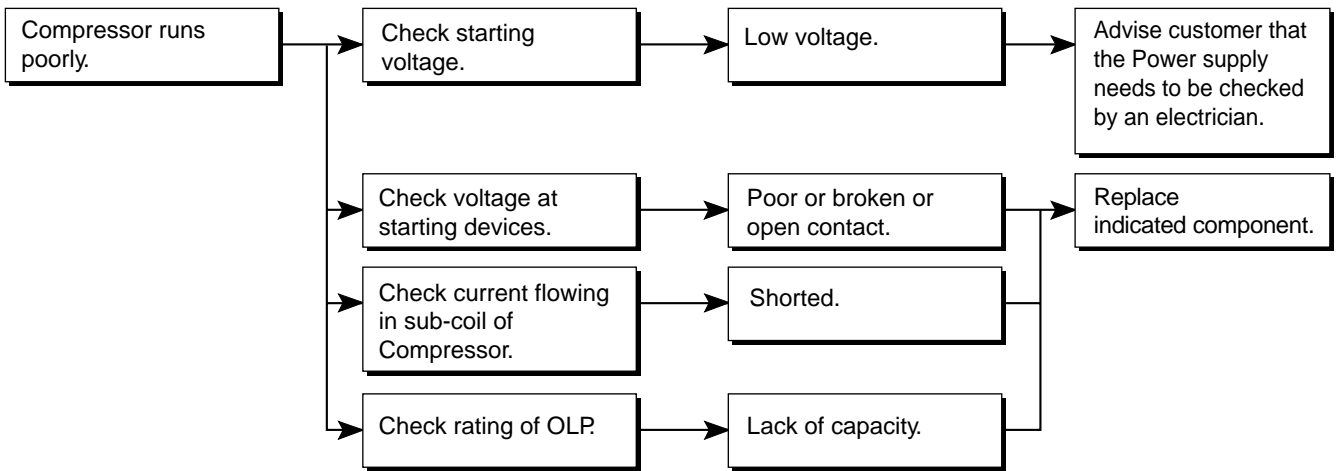

6-4 SERVICE DIAGNOSIS CHART

COMPLAINT	POINTS TO BE CHECKED	REMEDY
No Cooling.	<ul style="list-style-type: none"> • Is the power cord unplugged from the outlet? • Check if the power switch is set to OFF. • Check if the fuse of the power switch is shorted. • Measure the voltage of the power outlet. 	<ul style="list-style-type: none"> • Plug into the outlet. • Set the switch to ON. • Replace the fuse. • If the voltage is low, correct the wiring.
Cools poorly.	<ul style="list-style-type: none"> • Check if the unit is placed too close to the wall. • Check if the unit is placed too close to the stove, gas cooker, or in direct sunlight. • Is the ambient temperature too high or the room door closed? • Check if food put in the refrigerator is hot. • Did you open the door of the unit too often or check if the door is sealed properly? • Check if the Control is set to Warm position. 	<ul style="list-style-type: none"> • Place the unit about 4 inches (10 cm) from the wall. • Place the unit away from these heat sources. • Lower the ambient temperature. • Put in foods after they have cooled down. • Don't open the door too often and close it firmly. • Set the control to Recommended position.
Foods in the Refrigerator are frozen.	<ul style="list-style-type: none"> • Is food placed in the cooling air outlet? • Check if the control is set to colder position. • Is the ambient temperature below 41°F(5°C)? 	<ul style="list-style-type: none"> • Place foods in the high-temperature section. (front part) • Set the control to Recommended position. • Set the control to Warm position.
Condensation or ice forms inside the unit.	<ul style="list-style-type: none"> • Is liquid food sealed? • Check if food put in the refrigerator is hot. • Did you open the door of the unit too often or check if the door is sealed properly? 	<ul style="list-style-type: none"> • Seal liquid foods with wrap. • Put in foods after they have cooled down. • Don't open the door too often and close it firmly.
Condensation forms in the Exterior Case.	<ul style="list-style-type: none"> • Check if the ambient temperature and humidity of the surrounding air are high. • Is there a gap in the door gasket? 	<ul style="list-style-type: none"> • Wipe moisture with a dry cloth. It will disappear in low temperature and humidity. • Fill up the gap.
There is abnormal noise.	<ul style="list-style-type: none"> • Is the unit positioned in a firm and even place? • Are any unnecessary objects placed in the back side of the unit? • Check if the Drip Tray is not firmly fixed. • Check if the cover of the compressor enclosure in the lower front side is taken out. 	<ul style="list-style-type: none"> • Adjust the Leveling Screw, and position the refrigerator in a firm place. • Remove the objects. • Fix the Drip Tray firmly in the original position. • Place the cover in its original position.
Door does not close well.	<ul style="list-style-type: none"> • Check if the door gasket is dirty with an item like juice. • Is the refrigerator level? • Is there too much food in the refrigerator? 	<ul style="list-style-type: none"> • Clean the door gasket. • Position in the firm place and level the Leveling Screw. • Make sure food stored in shelves does not prevent the door from closing.
Ice and foods smell unpleasant.	<ul style="list-style-type: none"> • Check if the inside of the unit is dirty. • Are foods with a strong odor unwrapped? • The unit smells of plastic. 	<ul style="list-style-type: none"> • Clean the inside of the unit. • Wrap foods that have a strong odor. • New products smell of plastic, but this will go away after 1-2 weeks.

Other possible problems:

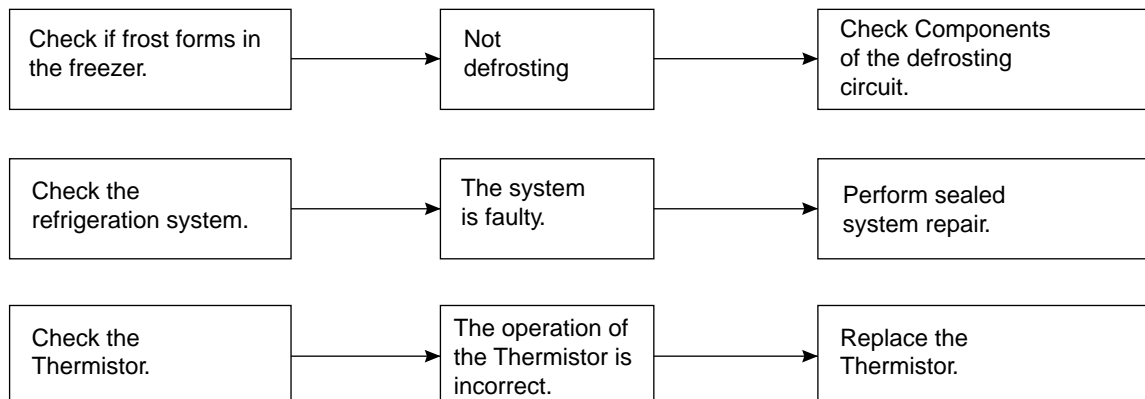

6-5 REFRIGERATION CYCLE

Troubleshooting Chart

CAUSE		STATE OF THE UNIT	STATE OF THE EVAPORATOR	TEMPERATURE OF THE COMPRESSOR	REMARKS
LEAKAGE	PARTIAL LEAKAGE	Freezer compartment and Refrigerator don't cool normally.	Low flowing sound of Refrigerant is heard and frost forms in inlet only.	A little higher than ambient temperature.	<ul style="list-style-type: none"> Refrigerant level is low due to a leak. Normal cooling is possible by restoring the normal amount of refrigerant and repairing the leak.
	COMPLETE LEAKAGE	Freezer compartment and Refrigerator don't cool normally.	Flowing sound of refrigerant is not heard and frost isn't formed.	Equal to ambient temperature.	<ul style="list-style-type: none"> No discharging of Refrigerant. Normal cooling is possible by restoring the normal amount of refrigerant and repairing the leak.
CLOGGED BY DUST	PARTIAL CLOG	Freezer compartment and Refrigerator don't cool normally.	Flowing sound of refrigerant is heard and frost forms in inlet only.	A little higher than ambient temperature.	<ul style="list-style-type: none"> Normal discharging of the refrigerant. The capillary tube is faulty.
	WHOLE CLOG	Freezer compartment and Refrigerator don't cool.	Flowing sound of refrigerant is not heard and frost isn't formed.	Equal to ambient temperature.	<ul style="list-style-type: none"> Normal discharging of the Refrigerant.
MOISTURE CLOG		Cooling operation stops periodically.	Flowing sound of refrigerant is not heard and frost melts.	Lower than ambient temperature.	<ul style="list-style-type: none"> Cooling operation restarts when heating the inlet of the capillary tube.
DEFECTIVE COMPRESSION	COMP-RESSION	Freezer and Refrigerator don't cool.	Low flowing sound of refrigerant is heard and frost forms in inlet only.	A little higher ambient temperature.	<ul style="list-style-type: none"> Low pressure at high side of compressor due to low refrigerant level.
	NO COMP-RESSION	No compressing operation.	Flowing sound of refrigerant is not heard and there is no frost.	Equal to ambient temperature.	<ul style="list-style-type: none"> No pressure in the high pressure part of the compressor.

Leakage Detection

Observe the discharging point of the refrigerant, which may be in the oil discharging part of the compressor and in a hole in the evaporator.

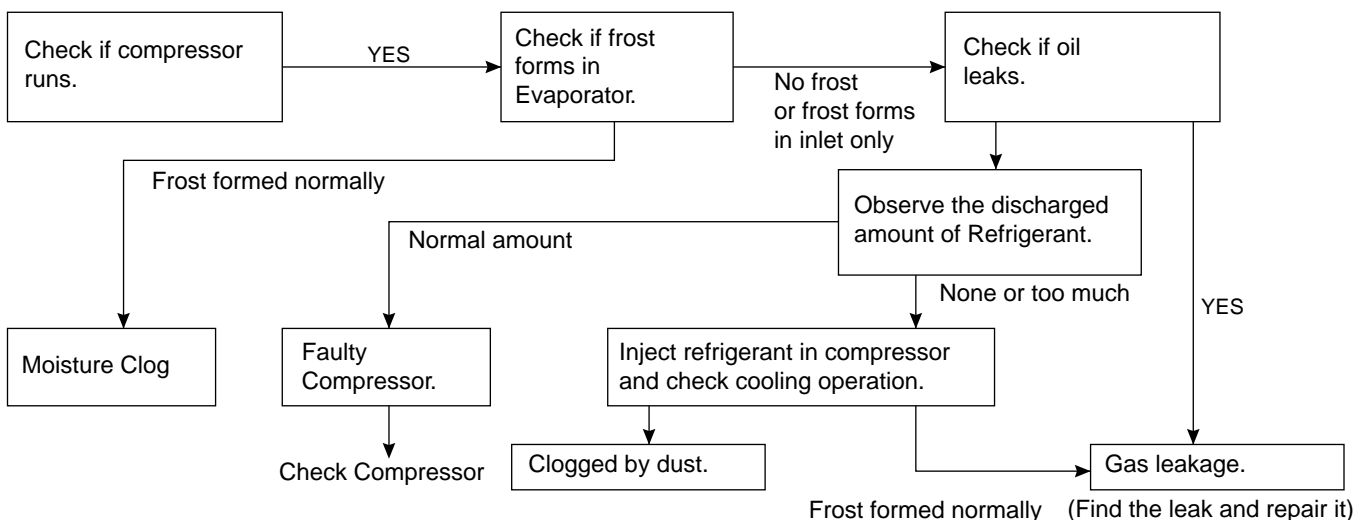

General Control of Refrigerating Cycle

NO.	ITEMS	UNIT	STANDARDS	PURPOSES	REMARKS
1	Pipe and piping system opening time	Min.	Pipe: within 1 hour. Comp: within 10 minutes. Drier: within 20 minutes.	To protect moisture penetration.	The opening time should be reduced to a half of the standards during rain and rainy seasons (the penetration of water into the pipe is dangerous).
2	Welding	Nitrogen pressure	Weld under Nitrogen atmosphere. (N ₂ pressure: 0.1~0.2 kg/cm ²)	To protect oxide scale formation.	- Refer to repair note in each part. - R-134a refrigerant is more susceptible to leaks than R-12 and requires more care during welding. - Do not apply force to pipes before and after welding to protect pipe from cracking.
3	N ₂ sealed parts	Confirm N ₂ leak	Confirm the sound of pressure relief when removing the rubber cap. Sound: usable No sound: not usable	To protect moisture penetration.	- In case of evaporator parts, if it doesn't make sound when removing rubber cap, blow dry air or N ₂ gas for more than 1 min. and then use the parts.
4	Refrigeration Cycle	Evacuation time Vacuum degree Vacuum Vacuum piping Pipe coupler Outlet (Socket) Plug	Min. Torr EA EA EA EA	More than 40 minutes Below 0.03 (ref) High and low pressure sides are evacuated at the same time for models above 200 l. Use R-134a manifold exclusively. Use R-134a manifold exclusively. R-134a manifold exclusively. R-134a manifold exclusively.	To remove moisture. Note: Only applicable to the model equipped with reverse flow protect plate. Vacuum efficiency can be improved by operating compressor during evacuation. The rubber pipes for R-12 refrigerant will be melted when they are used for R-134a refrigerant (causes of leak.) To protect mixing of mineral and ester oils. To protect R-12 refrigerant mixing. To protect R-12 refrigerant mixing. To protect R-12 refrigerant mixing.
5	Refrigerant weighing	EA	Use R-134a exclusively. Weighing allowance: ±5g Note: Winter: -5g Summer: +5g	Do not mix with R-12 refrigerant.	- Do not weigh the refrigerant at too hot or too cold an area. (77°F [25°C] is adequate.) - Make Copper charging canister (Device filling refrigerant) Socket: 2SV Plug: 2PV R-134a Note: Do not burn O-ring (bushing) during welding.
6	Drier replacement		- Use R-134a exclusively for R-134a refrigerator. - Replace drier whenever repairing refrigerator cycle piping.	To remove the moisture from pipe inside.	
7	Leak check		- Do not use soapy water for check. It may be sucked into the pipe by a vacuum.	Defect in refrigerant leak area.	- Check for an oil leak at the refrigerant leak area. Use an electronic leak detector if an oil leak is not found. - The electronic leak detector is very sensitive to halogen gas in the air. It also can detect R-141b in urethane. Practice many times before using this type of detector to avoid false readings.

7. OPERATION PRINCIPLE AND REPAIR METHOD OF ICEMAKER

7-1 OPERATION PRINCIPLE

7-1-1 Operation Principle of Icemaker

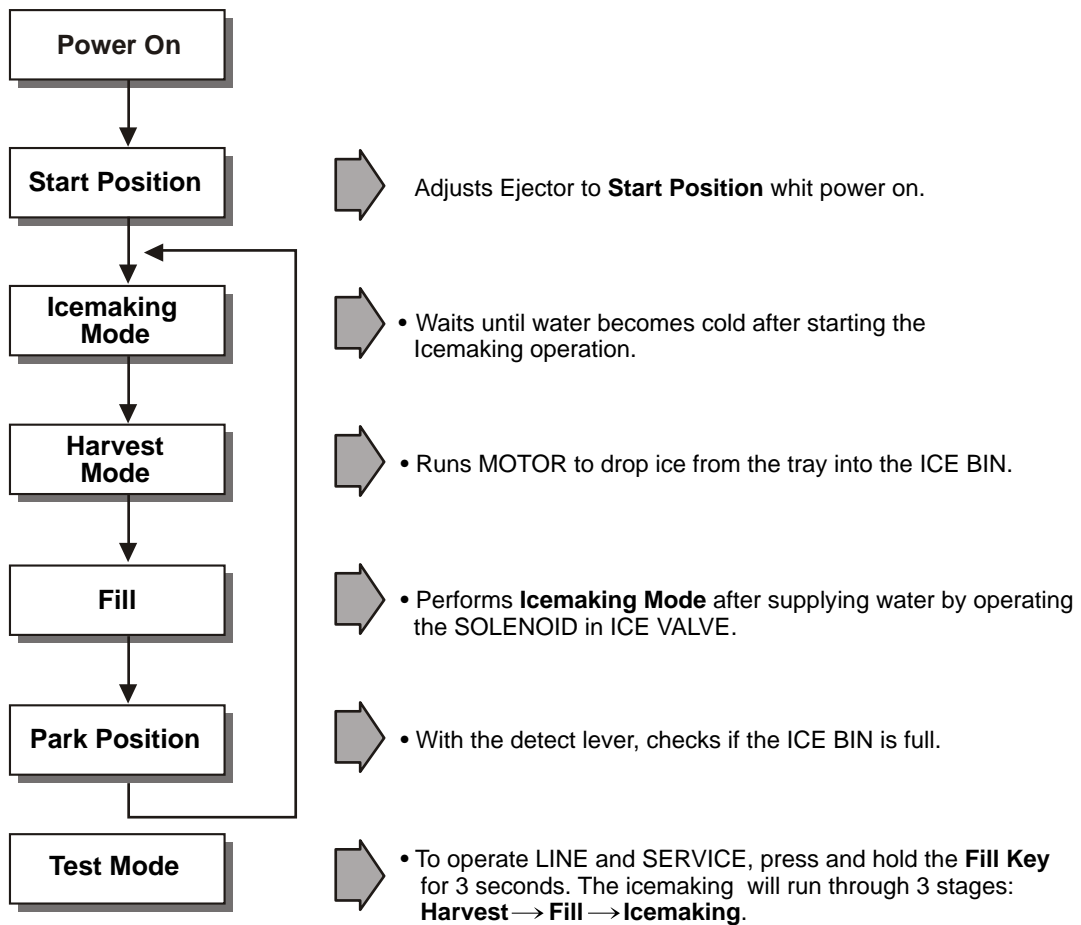

1. Turning the Icemaker stop switch off (O) stops the icemaking function.
2. Setting the Icemaker switch to OFF and then turning it back on will reset the icemaker control.

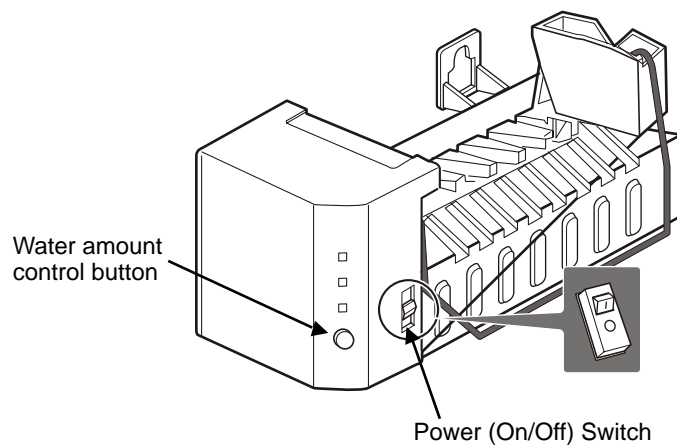

7-2 ICEMAKER FUNCTIONS

7-2-1 Start Position

1. After POWER OFF or Power Outage, check the EJECTOR's position with MICOM initialization to restart.
2. How to check if it is in place:
 - Check **HIGH/LOW** signals from HALL SENSOR in MICOM PIN.
3. Control Method to check if it is in place:
 - (1) EJECTOR is in place,
 - It is an initialized control, so the mode can be changed to icemaking control.
 - (2) EJECTOR isn't in place:
 - A. If EJECTOR is back in place within 2 minutes with the motor on, it is being initialized. If not, go to Step B.
 - B. If EJECTOR is back in place within 18 minutes after the heater turns from ON to OFF, it is being initialized. If not, it is not functioning. Repeat Step B with Heater and Motor off.

7-2-2 Icemaking Mode

1. Icemaking refers to the freezing of supplied water in the ice trays. Complete freezing is assured by measuring the temperature of the Tray with Icemaking SENSOR.
2. Icemaking starts after completion of the water fill operation.
3. The Icemaking function is completed when the sensor reaches -7°C , 60 to 240 minutes after starting.
4. If the temperature sensor is defective, the ice-making function will be completed in 4 hours.

NOTE :After icemaker power is ON, the icemaker heater will be on for test for 9 seconds.

7-2-3 Harvest Mode

1. Harvest (Ice removing) refers to the operation of dropping cubes into the ice bin from the tray when icemaking has Completed.
2. Harvest mode:
 - (1) The heater is ON for 30 seconds, then the motor starts.
 - (2) After performing Step 1 (the heater is turned OFF), the ejector will be back in place within 18 minutes. (Hall sensor sign = 0V). Ice removal is then complete. Then the icemaker cycles to the fill mode. The water supply fails to start, it is not functioning. Put the heater and motor in the off position. Restart every 2 hours. (Refer to figure1)

NOTE :If the motor malfunctions and starts before the detect lever rises, MICOM regards the Ice-Removing phase as completed. Water then starts flowing. To prevent this, MICOM doesn't switch to water-supply mode, but restarts the ice-removing mode. If this happens 3 times, the motor is malfunctioning and you should stop the loads (heater, motor). Then restart the Ice-Removing mode every 2 hours. (See Step 2 above.)

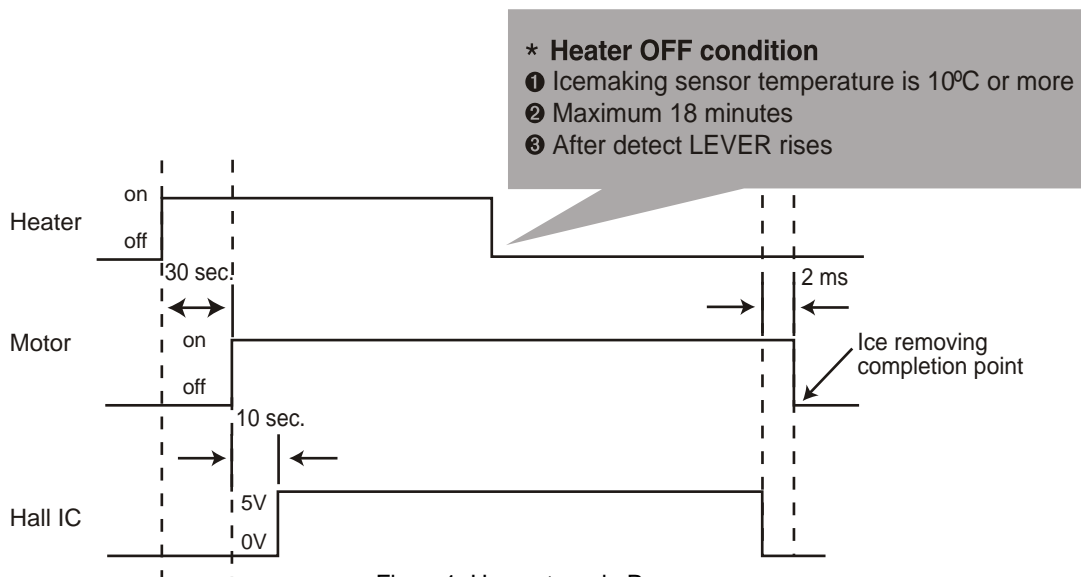





Figure1. Harvest mode Process

7-2-4 Fill/Park Position

1. Once a normal harvest mode has been completed, the water solenoid will be activated.
2. The amount of water is adjusted by pressing the Fill Key repeatedly. This changes the time allowed for fill as illustrated in the table below.

Water supply amount TABLE

STAGE	TIME TO SUPPLY	INDICATIONS	REMARKS
1	6 sec.		The water amount will vary depending on the water control switch setting, as well as the water pressure of the connected water line.
2	7 sec.		
3	8 sec.		



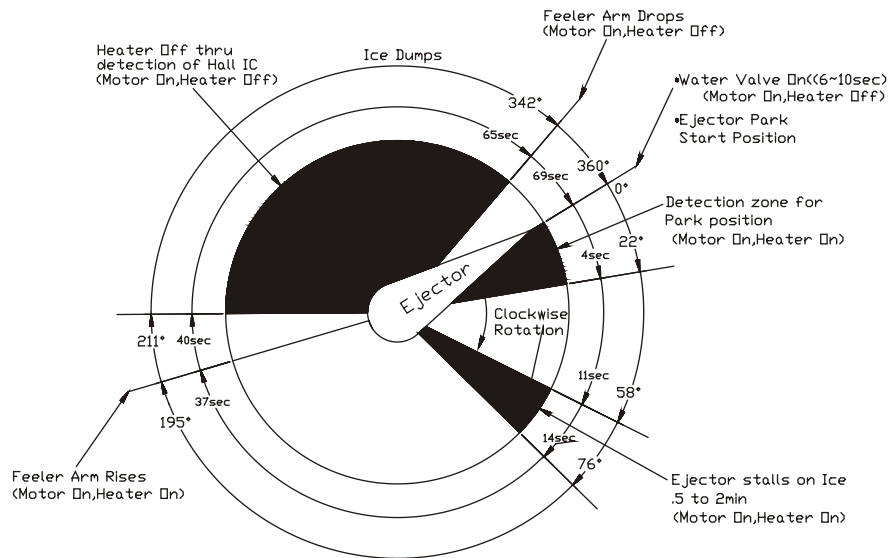

NOTE :Below is an example used by another vendor as an explanation of what is taking place.



7-2-5 Function TEST



1. This is a compulsory operation for test, service, cleaning, etc. It is operated by pressing and holding the fill key for 3 seconds.
2. The test works only in the Icemaking Mode. It cannot be entered from the Harvest or Fill mode. (If there is an ERROR, it can only be checked in the TEST mode.)
3. **Caution!** If the test is performed before water in the icemaker is frozen, the ejector will pass through the water. When the fill mode begins (Stage 4), unless the water supply has been shut off, added water will overflow into the ice bin. If the control Doesn't operate normally in the TEST mode, check and repair as needed.
4. After water is supplied, the normal CYCLE is followed: **icemaking** ⇌ **Harvest** ⇌ **Fill** ⇌ **Park Position**.
5. Five seconds after Stage 5 is completed, the icemaker returns to MICOM control. The time needed to supply water resets to the pre- test setting.

Diagnosis TABLE

STAGE	ITEMS	INDICATOR	REMARKS
1	HEATER		Five seconds after heater starts, heater will go off if temperature recorded by sensor is 10°C or lever is in up position.
2	MOTOR		Five seconds after heater starts, you can confirm that motor is moving.
3	HALL IC (TRAY)		You can confirm Hall IC detection of position.
4	SOLENOID VALVE		Two seconds after detection of initial position, you can confirm that valve is on.
5	HALL IC (LEVER)		You can check when the Hall IC is sensing a full ice condition. (If there is a water fill error, the fifth LED is not on.)
6	Reset	Return to Status prior to TEST MODE	Five seconds after fifth stage is completed, the icemaker resets to initial status.

7-3 DEFECT DIAGNOSIS FUNCTION

7-3-1 ERROR CODES shown on Ice Maker water supply control panel

NO	DIVISION	INDICATOR	CONTENTS	REMARKS
1	Normal	Mark time to supply	None	Display switch operates properly
2	Icemaking Sensor malfunction		Open or short-circuited wire	Make sure that the wire on each sensor is connected.
3	Icemaker Kit malfunction		When ejector blades don't reach park position over 18 minutes after harvest mode starts.	Check HALL IC/MOTOR/HEATER/RELAY

ERROR indicators in table can be checked only in TEST mode.

8. DESCRIPTION OF FUNCTION & CIRCUIT OF MICOM

8-1 FUNCTION

8-1-1 Function

1. When the appliance is plugged in, it is set to "4" for Refrigerator and "4" for freezer.
You can adjust the Refrigerator and the Freezer control temperature by pressing the ADJUST button.
2. When the power is initially applied or restored after a power failure, it is automatically set to "4" & "4".



8-1-2 Control of freezer fan motor

1. Freezer fan motor has high and standard RPMs
2. High RPM is used when electricity is first on, for ultra ice, and when refrigerator is overloaded, but standard RPM is used for general purposes.
3. To improve cooling speed and load corresponding speed, the RPM of freezer fan motor shall change from normal speed to high speed.
4. High speed (2500RPM) : Initial power on or load corresponding operation, ultra ice normal speed (2200RPM): General working conditions.
5. The fan motor is stopped when Refrigerator door is opened.
6. The fan motor is stopped when freezer door is opened (only if compressor status is OFF)

8-1-3 ULTRA ICE

1. The purpose of this function is to intensify the cooling speed of freezer and to increase the amount of ice.
2. Whenever selection switch is pressed, selection/release, the LED will turn ON or OFF.
3. If there is a power cut and the refrigerator is power on again, ULTRA ICE function will be canceled.
4. To activate these function you need to press the ULTRA ICE key and the LED will turn ON. This function will remain activated for 24 hrs. The first three hours the compressor and Freezer Fan will be ON. The next 21hours the freezer will be controlled at the lowest temperature. After 24 hours or if the ultra ice key is pressed again, the freezer will return to its previous temperature.
5. For the first three hours notice the following cases:
 - (1) Compressor and freezer fan(HIGH RPM) continuously operate for three hours.
 - (2) If defrost starts during ULTRA ICE, ULTRA ICE operates for the rest of time after defrost is completed, when ULTRA ICE operation time is less than 90 minutes.
If ULTRA ICE operates for more than 90minutes, the ULTRA ICE will operate for two hours after defrost is completed.
 - (3) If ULTRA ICE is pressed during defrost, ULTRA ICE LED is on but this function will start seven minutes after defrost is completed and it shall operate for three hours.
 - (4) If ULTRA ICE is selected within seven minutes after compressor has stopped, the compressor (compressor delays seven minutes) shall start after the balance of the delay time.
 - (5) The fan motor in the freezer compartment rotates at high speed during ULTRA ICE.
6. For the rest of 21 hours, the freezer will be controlled at the lowest temperature.

8-1-4. REFRIGERATOR LAMP AUTO OFF

1. To protect the risk of lamp heat, when Refrigerator door opens for 7 min., refrigerator lamp is auto off.

8-1-5 Alarm for Open Door

1. This feature sounds a buzzer when the freezer or refrigerator door is not closed within 1 minute after it is opened.
2. One minute after the door is opened, the buzzer sounds three times each for 1/2 seconds. These tones repeat every 30 seconds.
3. The alarm is cancelled when the freezer or the refrigerator is closed while the buzzer sounds.

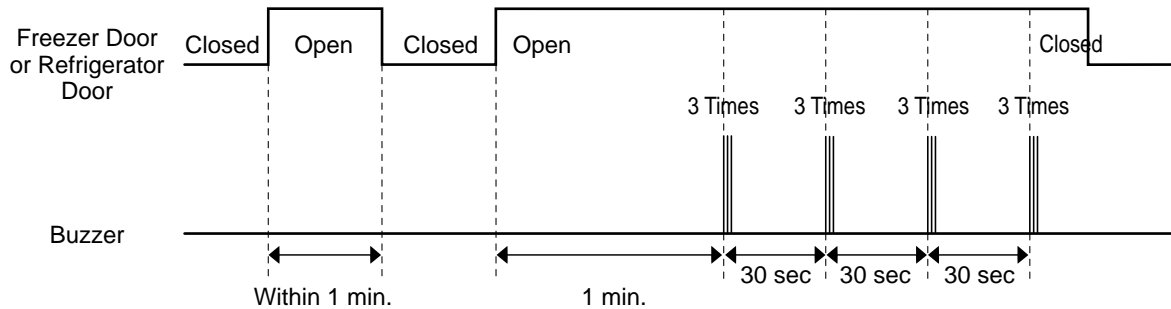

8-1-6 Buzzer Sound

When the button on the front Display is pushed, a Ding~ Dong~ sound is produced.

8-1-7 Defrosting (removing frost)

1. Defrosting starts each time when compressor running time reach 7 Hours, if any door hasn't been opened
2. In case of any Door has been opened the defrosting period will start considering the next conditions:
 If Compressor running time is bigger than 7 Hrs when door is opened: Defrosting starts immediately.
 If Compressor running time is less than 7 hours when door is opened: Defrosting starts after a compensation time is applied.
3. Defrosting stops if the sensor temperature reaches 46.4°F(8°C) or more. If the sensor doesn't reach 46.4°F(8°C) in 2 hours, the defrost mode is malfunctioning.)
4. Defrosting won't function if its sensor is defective (wires are cut or short circuited)

8-1-8 Electrical Parts Are Turned On Sequentially

Electrical parts such as COMP, defrosting heater, freezer FAN, etc. are turned on in the following order to prevent noise and parts damage. Several parts are started at the same time at initial power on and are turned off together when TEST is completed.

OPERATING		ORDERS				
Initial power on	Temperature of Defrosting Sensor is 45°C or more (when unit is newly purchased or when moved)	POWER ON	in 1/2 second →	COMP ON	in 1/2 second →	Freezer FAN ON
	Temperature of defrosting sensor is lower than 45°C (when power cuts, SERVICE)	POWER ON	in 1/2 second →	Defrosting heater ON	in 10 second →	Defrosting heater OFF
		in 1/2 second →	COMP ON	in 1/2 second →	Freezer FAN ON	
	Reset to normal operation from TEST MODE	Total load OFF	in 7 minute →	COMP ON	in 1/2 second →	Freezer FAN ON

8-1-8 Defect Diagnosis Function

1. Automatic diagnosis makes servicing the refrigerator easy.
2. When a defect occurs, the buttons will not operate; but the tones, such as ding, will sound.
3. When defect is repaired the defect code is removed and refrigerator returns to normal operation (RESET)
4. The Defect code is shown on the display.

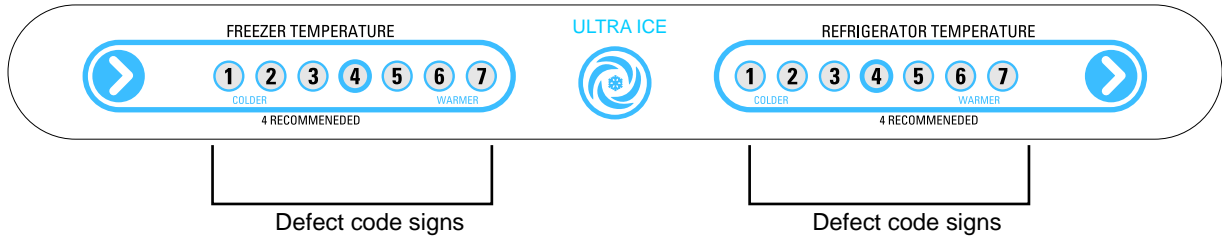

ERROR CODE on display panel

NO	ITEM	ERROR CODE						CONTENTS	REMARKS		
1	Failure of freezer sensor	All off	●	○	○	○	○	○	Cut or short circuit wire	Inspect Connecting wires on each sensor	
2	Failure of Refrigerator sensor	All off	○	●	○	○	○	○	Cut or short circuit wire		
3	Failure of defrost sensor	All off	○	○	●	○	○	○	Cut or short circuit wire		
4	Poor of defrost	All off	●	●	●	●	○	○	○	2hours later After starting defrost, If sensor doesn't be over 46°F (8°C)	Snapping of defrost heater or Temperature fuse, pull-out of Connector (indicated minimum 2 Hours after failure occurs)

8-1-10 TEST Mode

1. The Test mode allows checking the PCB and the function of the product as well as finding out the defective part in case of an error.
2. The test mode is operated by pressing two buttons at Display panel.
3. While in the test mode, the function control button is not recognized, but the recognition tone (beep~) sounds.
4. After exiting the test mode, be sure to reset by unplugging and then plugging in the appliance.
5. If an error, such as a sensor failure, is detected in the test mode, the test mode is cleared and the error code is displayed.
6. While an error code is displayed, the test mode will not be activated.

MODE	MANIPULATION	CONTENTS	REMARKS
TEST1	Push ULTRA ICE & ADJUST FREEZER TEMP Keys at the same time over 3 seconds.	<ol style="list-style-type: none"> 1. Continuous operation of the COMPRESSOR 2. Continuous operation of the freezer fan 3. STEPPING DAMPER OPEN 4. Defrosting Heater OFF 5. Every DISPLAY LED ON 	
TEST2	Push ULTRA ICE & ADJUST FREEZER TEMP Keys at the same time over 3 seconds in TEST MODE 1	<ol style="list-style-type: none"> 1. COMP OFF 2. Freezer FAN OFF 3. STEPPING DAMPER CLOSE 4. Defrosting heater ON 5. DISPLAY LED 1, 3, 5, 7 ON 	Reset if the temperature of the Defrosting sensor is 46°F (8°C) or more.
Reset	Push ULTRA ICE & ADJUST FREEZER TEMP Keys at the time over 3 seconds. in TEST MODE 2	Reset to the previously setting before TEST MODE	The compressor will Start after a 7-minute delay.

NOTE : LED CHECK MODE: When the ADJUST REFRIGERATOR TEMP KEY & ADJUST FREEZER TEMP Keys are pressed at the same time and hold for 1 second or longer, every LED on the display turns on at the same time. when the button are released, the previous mode is restored.

* Freezer Fan RPM Variable Check:

In case the freezer fan is in operation when the COLD KEY in Refrigerator and Freezer Temp. Control are pressed for more than one second at the same time freezer fan RPM changes. (for example if high speed, to normal speed or if normal speed, to high speed for 30 seconds)
After 30 seconds, it turns to its original RPM.

* Demonstration MODE:

1. When the ULTRA ICE key and ADJUST key of refrigerator temperature control are pressed for more than 3 seconds at the same time, temperature's it converts to demonstration mode.
2. In this status, each LED is rotated with 1 second interval.
3. In this status, all Loads are off (Compressor / Fan / Damper / Heater)
(Even is Demonstration Mode, the refrigerator Lamp automatic off function works normally and can be demonstrated)
4. It reset if you do again as clause.

8-2 PCB FUNCTION

8-2-1 Power Circuit

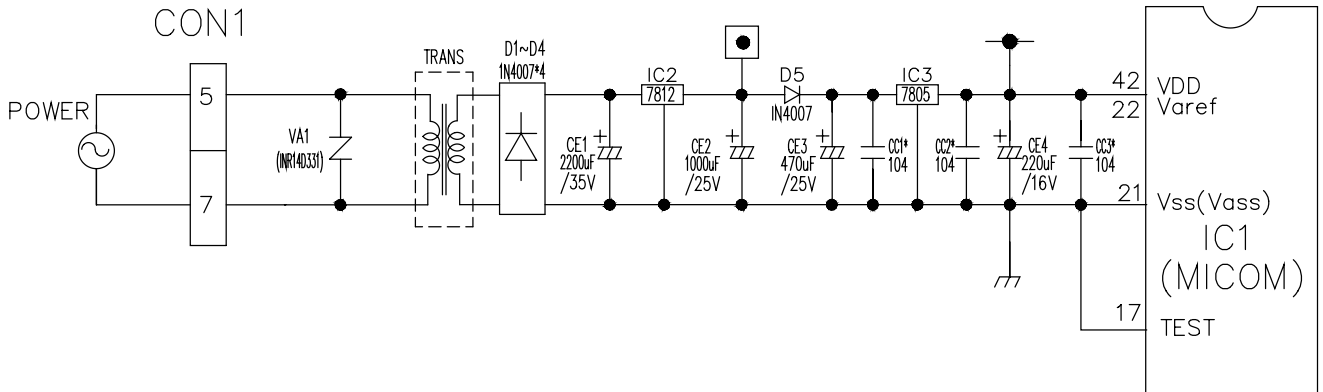

The secondary part of the TRANSFORMER is composed of the power supply for the display, The relay drive (12 Vdc) and the MICOM and IC (5 Vdc).

The voltage for each part is as follows:

PART	VA 1	CE 2	CE 1	CE 4
VOLTAGE	115 Vac	12 Vdc	15.5 Vdc	5 V

VA1 is a part for preventing over voltage and noise. When high voltage is applied, the inside elements are short-circuited and broken, resulting in blowout of the fuse in order to protect the elements of the secondary part of the TRANSFORMER.

8-2-2 Oscillation Circuit

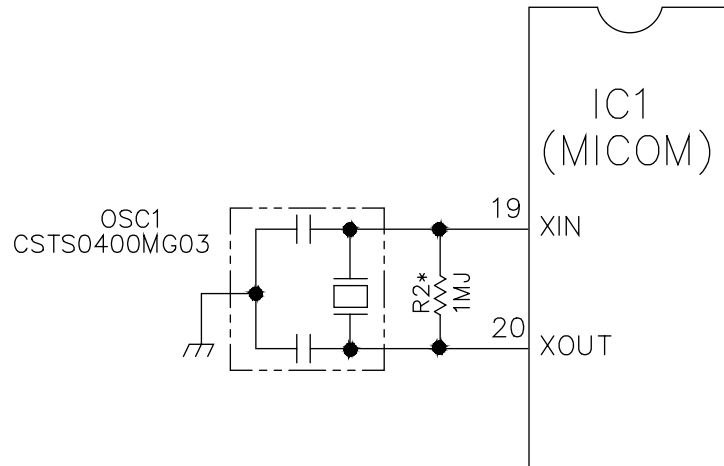

This circuit generates the base clock for calculating time and the synchro clock for transmitting data from and to the inside logic elements of the IC1 (MICOM). Be sure to use specific replacement parts, since calculating time by the IC1 may be changed. If changed, the OSC1 SPEC will not work.

8-2-3 Reset Circuit

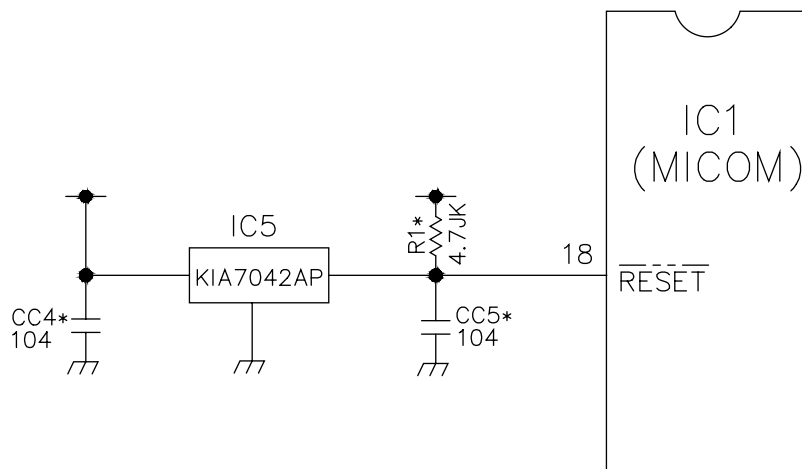

The RESET circuit allows all the functions to start at the initial conditions by initializing various parts, including the RAM inside the MICOM (IC1) when the power is initially supplied or the power supply to the MICOM is restored after a momentary power failure. For the initial 10ms of power supply, LOW voltage is applied to the MICOM RESET terminal. During a normal operation, 5V is applied to the RESET terminal. (If a malfunction occurs in the RESET IC, the MICOM will not operate.)

8-2-4 Load / Buzzer Drive & Open Door Detection Circuit

1. Load Drive Condition Check

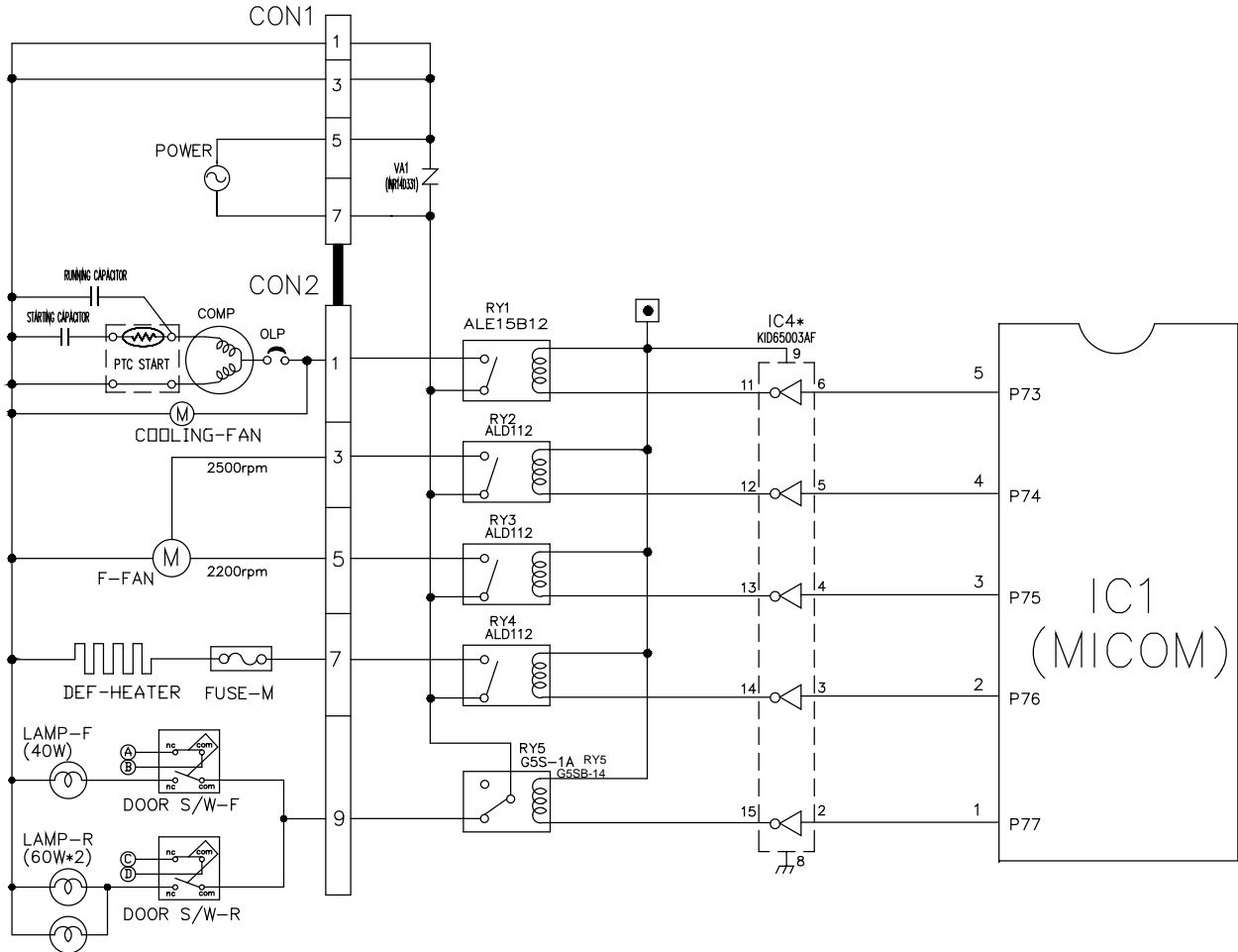

LOAD TYPE		COMP	DEFROSTING HEATER	LAMP	FREEZER FAN MOTOR (HIG RPM)	FREEZER FAN MOTOR (LOW RPM)
Measurement Location (IC4)		NO.11	NO.14	NO.15	NO.12	NO.13
Condition	ON	1V or below				
	OFF	12V				

2. Buzzer Drive Condition Check

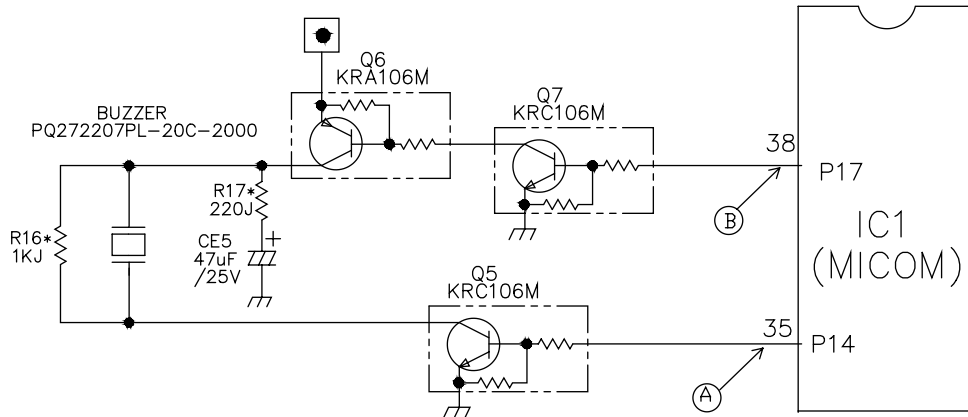

Condition Measurement Location	Tone (Ding~Dong~) when the button on the display is pushed.	Alarm for open door (beep-beep-beep)	OFF
IC1 (A)			0 V
IC1 (B)			0 V

3. Open Door Detection Circuit Check

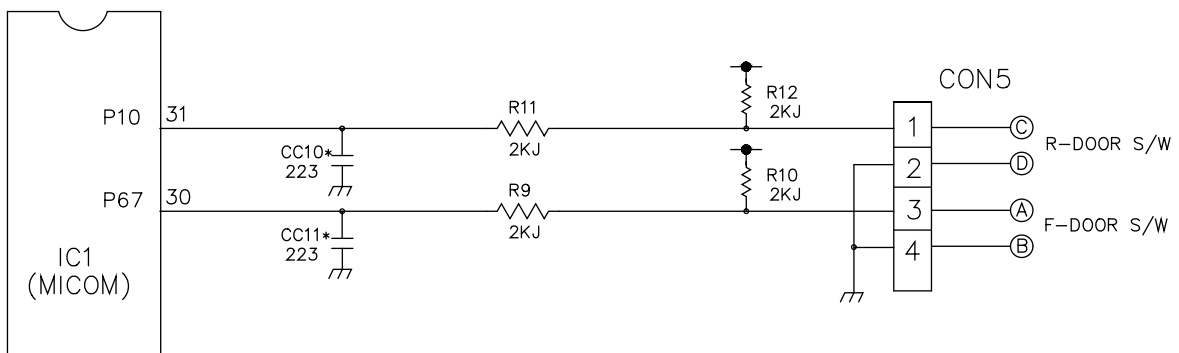

Measurement Location Freezer/ Refrigerator Door	(PIN NO.31 & PIN NO.30)
Closed	5 V
Open	0 V

8-2-5 Temperature Sensor Circuit

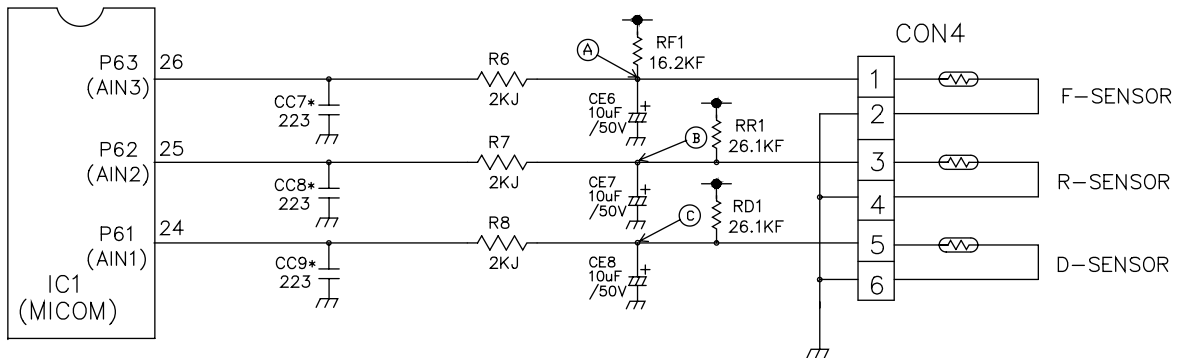

The upper CIRCUIT reads REFRIGERATOR temperature, FREEZER Temperature, and DEFROST-SENSOR temperature for defrosting and the indoor temperature for compensating for the surrounding temperature into MICOM. OPENING or SHORT state of each TEMPERATURE SENSOR are as follows:

SENSOR	CHECK POINT	NORMAL (-30°C ~ 50°C)	SHORT-CIRCUITED	OPEN
Freezer Sensor	POINT (A) Voltage	0.5 V ~ 4.5 V	0 V	5 V
Refrigerator Sensor	POINT (B) Voltage			
Defrosting Sensor	POINT (C) Voltage			

8-2-6 Refrigeration Compartment Stepping Motor Damper Circuit

* The circuit shown below is the damper circuit to regulate the refrigerator temperature.

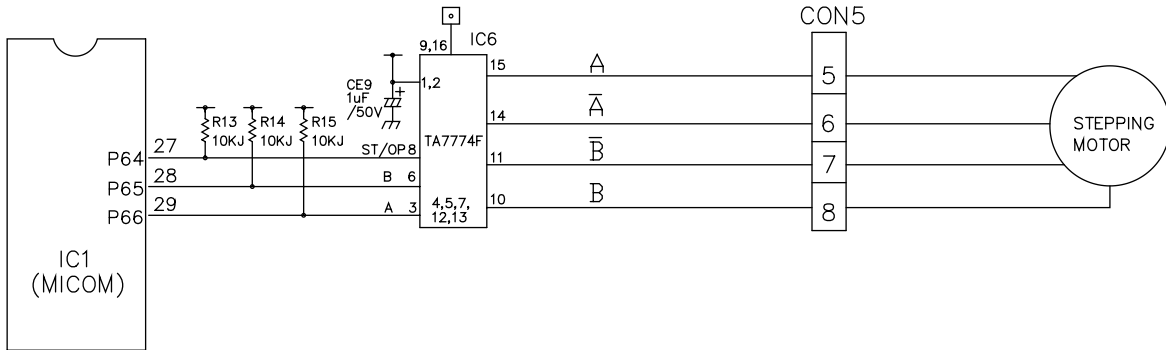

8-2-7 Temperature Compensation & Overcooling/Undercooling Compensation Circuit

1. Refrigerator Temperature Compensation

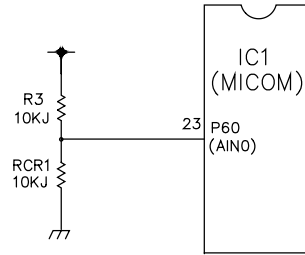

Refrigerator		Remark
Resistance (RCR)	Temperature Compensation	
180 K Ω	+2.5 °C	Compensation by raising the temperature ↑
56 K Ω	+2.0 °C	
33 K Ω	+1.5 °C	
18 K Ω	+1.0 °C	
12 K Ω	+0.5 °C	
10 K Ω	0 °C	Standard Temperature
8.2 K Ω	-0.5 °C	Compensation by lowering the temperature ↓
5.6 K Ω	-1.0 °C	
3.3 K Ω	-1.5 °C	
2 K Ω	-2.0 °C	
470 Ω	-2.5 °C	

Table of Temperature Compensation by adjusting the resistance (difference from the current temperature) e.g., If the refrigerator compensation resistance (RCR) is changed from 10K (the current resistance) to 18K (the adjustment resistance), the temperature of the refrigerator rises 33.8°F(+1°C).

2. The temperature compensation for refrigerator compartment is in the following table:

	Revised resistance	470 Ω	2k Ω	3.3k Ω	5.6k Ω	8.2k Ω	10k Ω	12k Ω	18k Ω	33k Ω	56k Ω	180k Ω
	Present resistance											
Refrigerator (RCR)	470 Ω	No change	0.5°C Up	1°C Up	1.5°C Up	2°C Up	2.5°C Up	3°C Up	3.5 °C Up	4°C Up	4.5°C Up	5°C Up
	2k Ω	0.5°C Down	No Change	0.5 C Up	1°C Up	1.5°C Up	2°C Up	2.5°C Up	3°C Up	3.5°C Up	4°C Up	4.5°C Up
	3.3k Ω	1°C Down	0.5°C Down	No Change	0.5°C Up	1°C Up	1.5°C Up	2°C Up	2.5°C Up	3°C Up	3.5°C Up	4°C Up
	5.6k Ω	1.5°C Down	1°C Down	0.5°C Down	No Change	0.5°C Up	1°C Up	1.5°C Up	2°C Up	2.5°C Up	3°C Up	3.5°C Up
	8.2k Ω	2°C Down	1.5°C Down	1°C Down	0.5° Down	No Change	0.5°C Up	1°C Up	1.5°C Up	2°C Up	2.5°C Up	3°C Up
	10k Ω	2.5°C Down	2°C Down	1.5°C Down	1°C Down	0.5°C Down	No Change	0.5°C Up	1°C Up	1.5°C Up	2°C Up	2.5°C Up
	12k Ω	3°C Down	2.5°C Down	2°C Down	1.5°C Down	1°C Down	0.5°C Down	No Change	0.5°C Up	1°C Up	1.5°C Up	2°C Up
	18k Ω	3.5°C Down	3°C Down	2.5°C Down	2°C Down	1.5°C Down	1°C Down	0.5°C Down	No Change	0.5°C Up	1°C Up	1.5°C Up
	33k Ω	4°C Down	3.5°C Down	3°C Down	2.5°C Down	2°C Down	1.5°C Down	1°C Down	0.5°C Down	No Change	0.5°C Up	1°C Up
	56k Ω	4.5°C Down	4°C Down	3.5°C Down	3°C Down	2.5°C Down	2°C Down	1.5°C Down	1°C Down	0.5°C Down	No Change	0.5°C Up
180k Ω	5°C Down	4.5°C Down	4°C Down	3.5°C Down	3°C Down	2.5°C Down	2°C Down	1.5°C Down	1°C Down	0.5°C Down	No Change	

NOTE: This circuit is designed to input the necessary temperature compensation values into the MICOM. This adjusts the refrigerator temperature, which is different in each model.

8-2-8 Key Button Input & Display Light-On Circuit

The circuit shown above determines whether a function control key on the operation display is pushed. It also turns on the corresponding function indication LED DISPLAY. The drive type is the scan type.

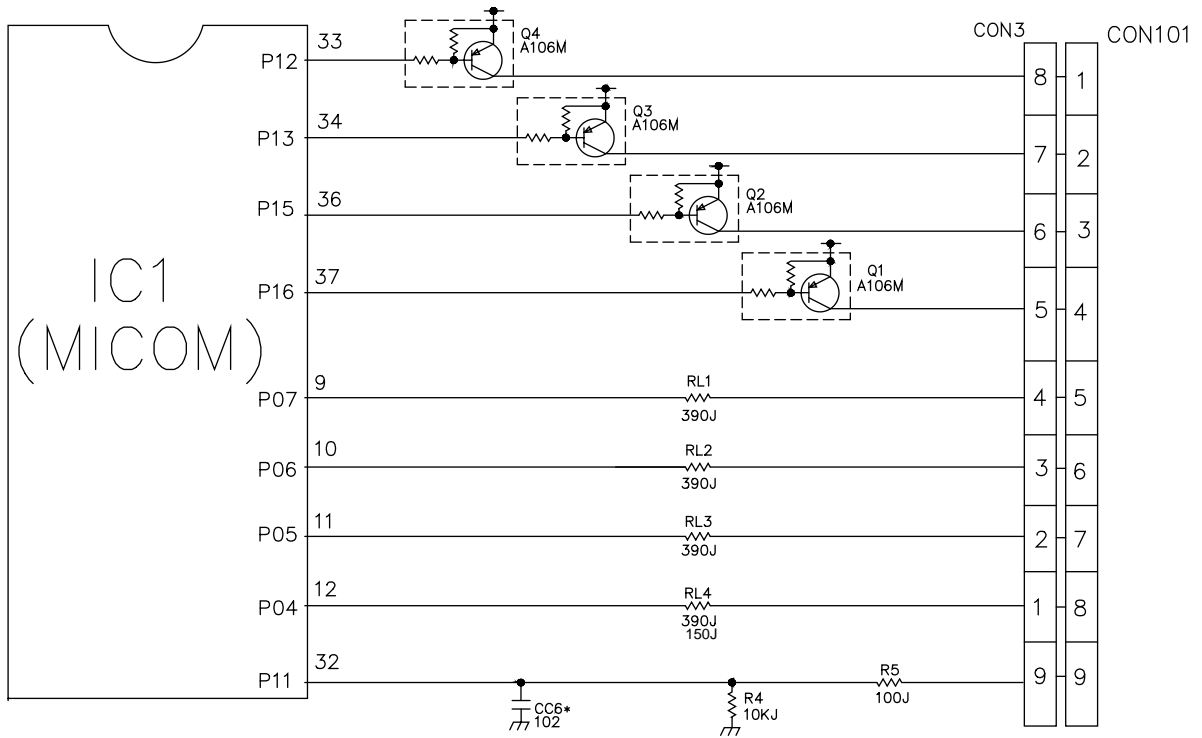

8-3 RESISTANCE SPECIFICATION OF SENSOR

TEMPERATURE DETECTED BY SENSOR	RESISTANCE OF FREEZER SENSOR	RESISTANCE OF REFRIGERATOR & DEFROST SENSOR & ROOM SENSOR
- 20 °C	22.3 KΩ	77 KΩ
- 15 °C	16.9 KΩ	60 KΩ
- 10 °C	13.0 KΩ	47.3 KΩ
- 5 °C	10.1 KΩ	38.4 KΩ
0 °C	7.8 KΩ	30 KΩ
+ 5 °C	6.2 KΩ	24.1 KΩ
+ 10 °C	4.9 KΩ	19.5 KΩ
+ 15 °C	3.9 KΩ	15.9 KΩ
+ 20 °C	3.1 KΩ	13 KΩ
+ 25 °C	2.5 KΩ	11 KΩ
+ 30 °C	2.0 KΩ	8.9 KΩ
+ 40 °C	1.4 KΩ	6.2 KΩ
+ 50 °C	0.8 KΩ	4.3 KΩ

- The resistance of the SENSOR has a $\pm 5\%$ common difference.
- Measure the resistance of the SENSOR after leaving it for over 3 minutes in the measuring temperature. This delay is necessary due to sensor response speed.

8-4 TROUBLESHOOTING

PROBLEM	INDICATED BY	CHECK	CHECKING METHOD	CAUSE	SOLUTION
POWER SOURCE is poor.	1. The whole DISPLAY LED/SEVEN SEGMENT DISPLAY is off. 2. DISPLAY LED/SEVEN SEGMENT DISPLAY operates abnormally	1. FREEZER/REFRIGERATOR. 2. If LAMP is dim. 3. The connection of the MAIN PWB CONNECTOR.	Check if FREEZER/REFRIGERATOR DOOR IS OPEN and check display. Check visually. Check connection of CONNECTOR.	POWER SOURCE is poor.	Check outlet Voltage.
				Applied voltage error. CONNECTOR connection is poor. TRANS FUSE is open.	Use boosting TRANS. Reconnect CONNECTOR. Replace TRANS.
COOLING is poor.	NO COOLING.	1. If the COMPRESSOR operate. 2. If refrigerant is leaking	USE TEST MODE1 (forced COOLING). If less than 7 minutes pass after compressor shuts off, don't press the KEY and wait. Measure the amount of frost sticking on EVAPORATOR and the surface temperature of the condenser pipe.	COMPRESSOR locked or blocked. OLP, PTC is poor. COMPRESSOR RELAY is poor. THE CONNECTING WIRE is poor.	Replace COMPRESSOR. Replace OLP, PTC. Replace MAIN PWB. Check the connection of the black wire of the MAIN PWB CONNECTOR (CON2).
				Refrigerant leakage. FAN MOTOR is poor. CONNECTING WIRE is poor.	Replace the leaking part and replace any lost refrigerant. Replace the FAN MOTOR. Certify the MOTOR and the connection of the black wire of the MAIN PWB CONNECTOR (CON2).
FREEZER TEMPERATURE is incorrect		1. If FAN MOTOR operates. 2. If DEFROSTING is normal. 3. If SENSOR is normal. 4. Door Line contact.	USE TEST MODE1 (forced COOLING). Check the amount of frost sticking on the EVAPORATOR. Check the resistance of the Refrigerator SENSOR. Check the seal when the door is closed.	DEFROSTING is poor.	See DEFROSTING is poor.
				SENSOR RESISTANCE is poor.	Replace SENSOR.
				Door liner damaged.	Replace door liner.

PROBLEM	INDICATED BY	CHECK	CHECKING METHOD	CAUSE	SOLUTION
COOLING is poor.	If REFRIGERATOR TEMPERATURE is too low.	1. If FREEZER TEMPERATURE is normal.	Check is FREEZER TEMPERATURE is too low.	FAN MOTOR is poor.	Make sure the DOOR is attached. Replace FAN MOTOR.
		2. If amount of cool air from FAN MOTOR is sufficient.	Make sure that the amount and speed of cool air are sufficient by touching the check supplied on the REFRIGERATOR.	Passage of cool air is blocked. EVA frozen.	Remove impurities. See DEFROSTING is poor
		3. Door Line contact.	Check door seal when door is closed.	Door liner damaged.	Replace Door liner.
DEFROSTING is poor.	NO DEFROSTING.	1. If HEATER emits heat.	USE TEST MODE2 (forced DEFROSTING).	HEATER disconnection.	Replace HEATER.
				TEMPERATURE FUSE disconnection.	Replace TEMPERATURE FUSE.
				Connection is poor.	Check EVAPORATOR connection and wire of MAIN PWB CONNECTOR.
				DEFROST-SENSOR is poor.	Replace DEFROST-SENSOR.
				HEATER RELAY is poor.	Replace RY3 of MAIN PWB.
				DRAIN PIPE is blocked.	Remove ice and impurities. Check HEATER PLATE resistance.
3. If ice remains after DEFROSTING.	Make sure that DEFROST SENSOR is connected. Make sure that FREEZER / REFRIGERATOR DOOR is closed.	3. If ice remains after DEFROSTING.	Make sure that DEFROST SENSOR is connected. Make sure that FREEZER / REFRIGERATOR DOOR is closed.	Connection is poor.	Reassemble the DEFROST-SENSOR.
				DOOR does not close properly.	Reassemble DOOR. Replace GASKET.

8-5 MAIN PWB ASSEMBLY AND PARTS LIST

8-5-1 Main PWB Assembly

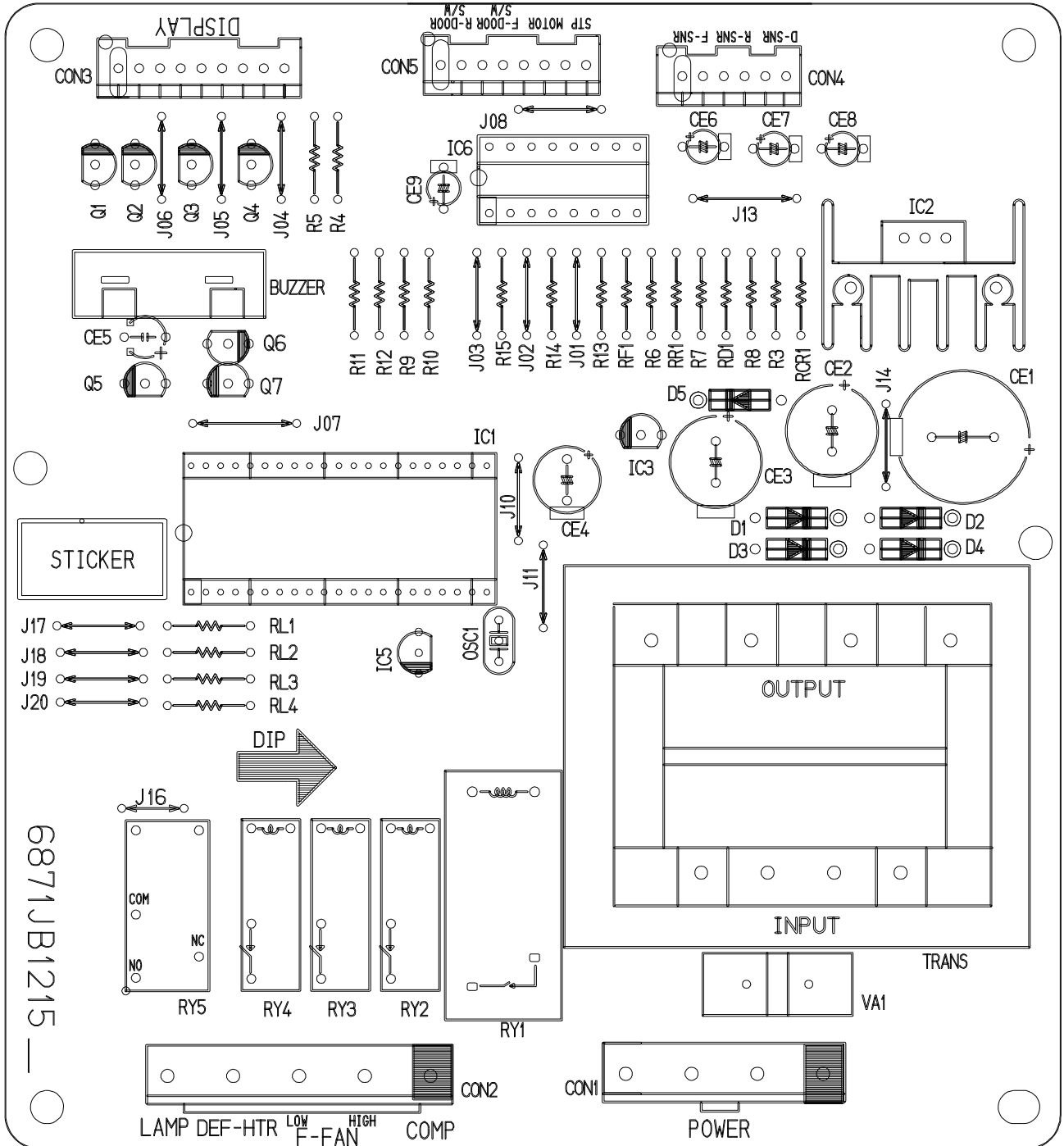

8-5-2 Replacement Parts List

No	P/NO	DESCRIPTION	SPEC	MAKER	REMARK
1	6870_BB889A = C	PWB(PCB)	KS-PJT GOOD MDL	DOO SAN	T-1.6
2	-	-	-	-	-
3	6170_B2002H	TRANSFORMER,LOW VOLTAGE	240V 15V YES GR-MICOM ONE TAB	TAE SUNG	TRANS
4	6170_B2002M	TRANSFORMER,LOW VOLTAGE	260V 15V YES GR-MICOM ONE TAB	TAE SUNG	TRANS
5	6170_B2002R	TRANSFORMER,LOW VOLTAGE	140V 15V YES GR-MICOM ONE TAB	TAE SUNG	TRANS
6	6170_B2002W	TRANSFORMER,LOW VOLTAGE	115V 15V YES GR-MICOM ONE TAB	TAE SUNG	TRANS
7	-	-	-	-	-
8	6630A09106C	CONNECTOR (ICIRC),WAFER	YH396-07AV YEONHO 7PIN 3.96MM STRAIGHT SN	YEON HO	CON1
9	6630A09106D	CONNECTOR (ICIRC),WAFER	YH396-09AV	YEON HO	CON2
10	6630A09106B	CONNECTOR (ICIRC),WAFER	YH396-05AV	YEON HO	-
11	6630_B8007G	CONNECTOR (ICIRC),WAFER	917786-1 AMP 8PIN 2.5MM STRAIGHT SN	AMP	CON5
12	6630_B8007H	CONNECTOR (ICIRC),WAFER	917787-1 AMP 9PIN 2.5MM STRAIGHT SN	AMP	CON3
13	6630_B8007E	CONNECTOR (ICIRC),WAFER	917784-1 AMP 6PIN 2.5MM STRAIGHT SN	AMP	CON4
14	-	-	-	-	-
15	01ZZ_B2023L	IC,DRAWING	TMF87C84GN 42 SDIP BK KS-BETTER/GOOD(MASK)	TOSHIBA	IC1(01ZZ_B2022M)
16	01ZZ_B2022	IC,DRAWING	-	TOSHIBA	IC1(01ZZ_B2022)
17	01ZZ_B2022	IC,DRAWING	-	TOSHIBA	IC1(01ZZ_B2022)
18	-	-	-	-	-
19	01KE781200B	IC,KEC	K1A7812P1 12V IA,KEC - - - -	KEC	IC2
20	01KE781200M	IC,KEC	K1A7812P1 30IP BK 12V IA REFORM	KEC	-
21	01KE780500A	IC,KEC	K1A7805P,3PIN,DIP - KEC	KEC	IC3
22	01STLM001A	IC,STANDARD LOGIC	M54563P MITSUBISHI 20 R/TP CONVERT	MITSUBISHI	-
23	01T0777400A	IC,TOSHIBA	TA7774AP 16 SDIP BK STEPPING MOTOR	TOSHIBA	IC6
24	01KE650030C	IC,KEC	K1D65003AF 16SOP BK 7CH DRIVER	KEC	IC4
25	01KE704200A	IC,KEC	K1A7042P 3P BK RESET	KEC	IC5
26	01FH434600D	IC,ROHM	BR93LC46FF-W 8PIN SOP BK EEPROM -	ROHM	-
27	-	-	-	-	-
28	6920000001A	RELAY	ALE15B12 MATSUSHITA 250VAC 16A 12VDC IA NO VENTING	NAIS	RY1
29	6920W0010A	RELAY	US11-125 YUYU 250VAC 3A 12VDC IA	YUYU	-
30	6920_B2003B	RELAY	ALD112 MATSUSHITA 250VAC 3A 12VDC IA	OMRON	RY2-RY4
31	6920_B2009A = B	RELAY	696B-14 250VAC 5A 12VDC IC	OMRON	RY5
32	-	-	-	-	-
33	-	-	-	-	-
34	6212_B8001B	RESONATOR,CERAMIC	CST90400 MURATA 4MHZ +/- 0.5% 15PF TP NONE	MURATA	OSC1(J570-00012B)
35	6102W5V006A	VARIABLE	INR14D331 ILJIN UL/CSA/VDE BK	ILJIN	VA1
36	6102_B8003A	VARIABLE	INR14D271 ILJIN UL/VDE TP 270V	ILJIN	VA1
37	6102_B8001B	VARIABLE	INR14D621 ILJIN UL/VDE BK 620V	ILJIN	VA1
38	0DD400709AA	DIODE,RECTIFIERS	IN4007 TP MOTOROLA - - IA - - -	DELTA	DI-05
39	-	-	-	-	-
40	-	-	-	-	-
41	0CE2285J610	CAPACITOR,AL.,ELECTROLYTIC	2200 UF 5MS,SG 35V M FL BULK	SAM HWA	CE1
42	0CE1086J610	CAPACITOR,AL.,ELECTROLYTIC	1000UF 5MS,SG 35V 20% FL BULK	SAM HWA	-
43	0CE1086H618	CAPACITOR,AL.,ELECTROLYTIC	1000 UF 5MS,SG 25V M FL TP 5	SAM HWA	CE2
44	0CE4776H618	CAPACITOR,AL.,ELECTROLYTIC	470UF 5MS,SG 25V 20% FL TP 5	SAM HWA	CE3
45	0CE2276F638	CAPACITOR,AL.,ELECTROLYTIC	220UF 5MS,SG 16V 20% FM5 TP 5	SAM HWA	CE4
46	0CE1076H638	CAPACITOR,AL.,ELECTROLYTIC	100UF 5MS,SG 25V 20% FM5 TP 5	SAM HWA	-
47	0CE1066K638	CAPACITOR,AL.,ELECTROLYTIC	100UF 5MS,SG 50V 20% FM5 TP 5	SAM HWA	CE6-CE8
48	0CE1056K638	CAPACITOR,AL.,ELECTROLYTIC	10UF 5MS,SG 50V 20% FM5 TP 5	SAM HWA	CE9
49	0CE4761H638	CAPACITOR,AL.,ELECTROLYTIC	47UF 5MS,SG 25V 20% FM5 TP 5	SAM HWA	CE5
50	0C02231N409	CAPACITOR,POLYESTER	0.022 UF D 100V J PE TP	SAM HWA	-
51	0CK1020K96A	CAPACITOR,CERAMIC(HIGH DIELECTRIC)	1NF 2012 50V 80%, -20% R/TP X7R	-	CC6
52	0CK2230K96A	CAPACITOR,CERAMIC(HIGH DIELECTRIC)	22NF 2012 50V 80%, -20% R/TP X7R	MURATA	CC7-CC11
53	-	-	-	-	-
54	0CK1040K94A	CAPACITOR,CERAMIC(HIGH DIELECTRIC)	100NF 2012 50V R/TP (GRM40X7R104K50PE)	MURATA	CC1-CC5
55	-	-	-	-	-
56	0CK1040K949	CAPACITOR,CERAMIC(HIGH DIELECTRIC)	0.1UF D 50V 80%, -20% F1Y5V1 TA52	-	-
57	-	-	-	MURATA	-
58	-	-	-	-	-
59	0RD15006609	RESISTOR,FIXED CARBON FILM	150 OHM 1/4W 5.00% TA52	SMART	RL4
60	0RD39006609	RESISTOR,FIXED CARBON FILM	390 OHM 1/4 W 5.00% TA52	SMART	RL1-RL3
61	0RD10006609	RESISTOR,FIXED CARBON FILM	100 OHM 1/4 W 5.00% TA52	SMART	R5
62	0RJ1001E672	RESISTOR,METAL GLAZED(CHIP)	1K OHM 1/8 W 5% 2012 R/TP	ROHM	R16
63	0RJ2001E672	RESISTOR,METAL GLAZED(CHIP)	2K OHM 1/8 W 5% 2012 R/TP	ROHM	-
64	0RD20016609	RESISTOR,FIXED CARBON FILM	2K OHM 1/4 W 5.00% TA52	SMART	R6-R12
65	0RH2200L622	RESISTOR,METAL GLAZED(CHIP)	220 OHM 1/8 W 5% 2012 5.00% D	ROHM	R17
66	0RJ2201E672	RESISTOR,METAL GLAZED(CHIP)	2.2K OHM 1/8 W 5% 2012 R/TP	ROHM	-
67	0RJ4701E672	RESISTOR,METAL GLAZED(CHIP)	4.7K OHM 1/8 W 5% 2012 R/TP	ROHM	R1
68	0RJ4701E672	RESISTOR,METAL GLAZED(CHIP)	4.7K OHM 1/8 W 5% 2012 R/TP	ROHM	-
69	0RD47016609	RESISTOR,FIXED CARBON FILM	4.7K OHM 1/4 W 5.00% TA52	SMART	-
70	0RJ1002E672	RESISTOR,METAL GLAZED(CHIP)	10K OHM 1/8 W 5% 2012 R/TP	ROHM	-
71	0RJ1002E672	RESISTOR,METAL GLAZED(CHIP)	10K OHM 1/8 W 5% 2012 R/TP	ROHM	-
72	0RD10026609	RESISTOR,FIXED CARBON FILM	10K OHM 1/4 W 5.00% TA52	SMART	R3,R4,RCR1,R13-R15
73	0RJ2702E672	RESISTOR,METAL GLAZED(CHIP)	27K OHM 1/8 W 5% 2012 R/TP	ROHM	-
74	0RJ1004E672	RESISTOR,METAL GLAZED(CHIP)	1M OHM 1/8 W 5% 2012 R/TP	ROHM	R2
75	0RJ2612E472	RESISTOR,FIXED METAL FILM	26.1K OHM 1/4 W 1.00% TA52	SMART	RR1, RD1
76	0RJ1622E472	RESISTOR,FIXED METAL FILM	16.2K OHM 1/4 W 1.00% TA52	SMART	RF1
77	-	-	-	-	-
78	-	-	-	-	-
79	3J03565D	FUSE,DRAWING	9A 250V - -	SAM JU	-
80	0TRI06009AC	TRANSISTOR	KRA106MIKRA22061 TP KEC	KEC	Q1-Q4
81	0TRI06009AF	TRANSISTOR	KRC 106M KEC	KEC	Q5,Q7
82	0TR319809AA	TRANSISTOR	KTC3198-TP-Y (KTC1815)KEC	KEC	-
83	6908_B3002F	BUZZER	CBE22208P DAE YOUNG P1E20 2KHZ 750B1CH1NA1	DAE YOUNG	BUZZER
84	6600RRT001Z	SWITCH,TACT	JTP1280A6 JEIL 12V DC 50MA	JEIL	-
85	6854B50001A	JUMP WIRE	0.6MM 52MM TP TAPING SN(6MM)	-	J16
86	6854B50001A	JUMP WIRE	0.6MM 52MM TP TAPING SN(10MM)	-	J1-J5, J8, J10, J14, J17-J20
87	6854B50001A	JUMP WIRE	0.6MM 52MM TP TAPING SN(12.5MM)	-	J13
88	6854B50001A	JUMP WIRE	0.6MM 52MM TP TAPING SN(12.5MM)	-	J07
89	6854B50001A	JUMP WIRE	0.6MM 52MM TP TAPING SN	-	-
90	6854B50001A	JUMP WIRE	0.6MM 52MM TP TAPING SN	-	-
91	4920_B3003A	HEAT SINK	30*25*30 IC-12V R-B50,51,52,53,54,55,56 2PIN 1-SCREW 3	-	HC21
92	15BF030241B	SCREW TAP TITE(S),BINDING HEAD	+ D3.0 LB.0 M5WR3/FZY	-	HC21
93	9WV0120000	SOLDER(ROSN WIRE) R50	DI.20	HEE SUNG	-
94	49111004	SOLDER,SOLDERING	H63A	-	-
95	59333105	FLUX	SG;0.825-0.830 KOREA F.H-206	KOKI	-

8-5-3 PWB Assembly, Display, And Parts List

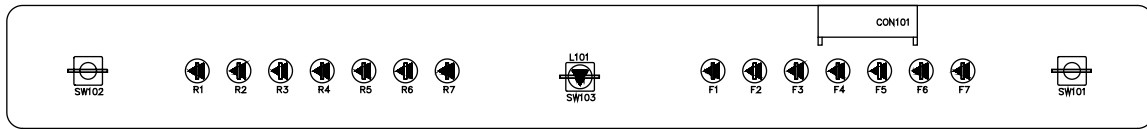

Qty	No	P/NO	DESCRIPTION	SPEC	MAKER	REMARK
1	1	6870JB8091A	PWB(PCB)	KS-PJT GOOD/BETTER DISPLAY	DOO SAN	t=1.6
	2					
1	3	6630AQ9159H	WAFER	SMAW250-09	YEON HO	CON101
	4					
2	5	6600RRT002K 6600JB8005A	SWITCH,TACT	JTP1230A JEIL 12V DC 50MA KPT-1105A	JEIL KYUNG IN	SW101,102
1	6	-	TACT S/W	KPT-1109G	KYUNG IN	SW103
14	7	0DLLE0019AA	LED	LT1824-81-BCM TP GREEN 2		R1~R7,F1~F7
3	8	0DD414809AA	DIODE,SWITCHING	1N4148 26MM	PYUNG CHANG DELTA	D101,102,103
12	10	6854B50001A	JUMP WIRE	0.6MM 52MM TP TAPING SN <10MM>	-	J101~J112
	11					
-	12	9VWF0120000	SOLDER(ROSN WIRE) RSO	D1.20	HEE SUNG	-
001	13	49111004	SOLDER,SOLDERING	H63A	-	-
0.0005	14	59333105	FLUX	SG;0.825-0.830 KOREA F.H-206	KOKI	-

8-6 PWB DIAGRAM

8-6-1 PWB Main Assembly

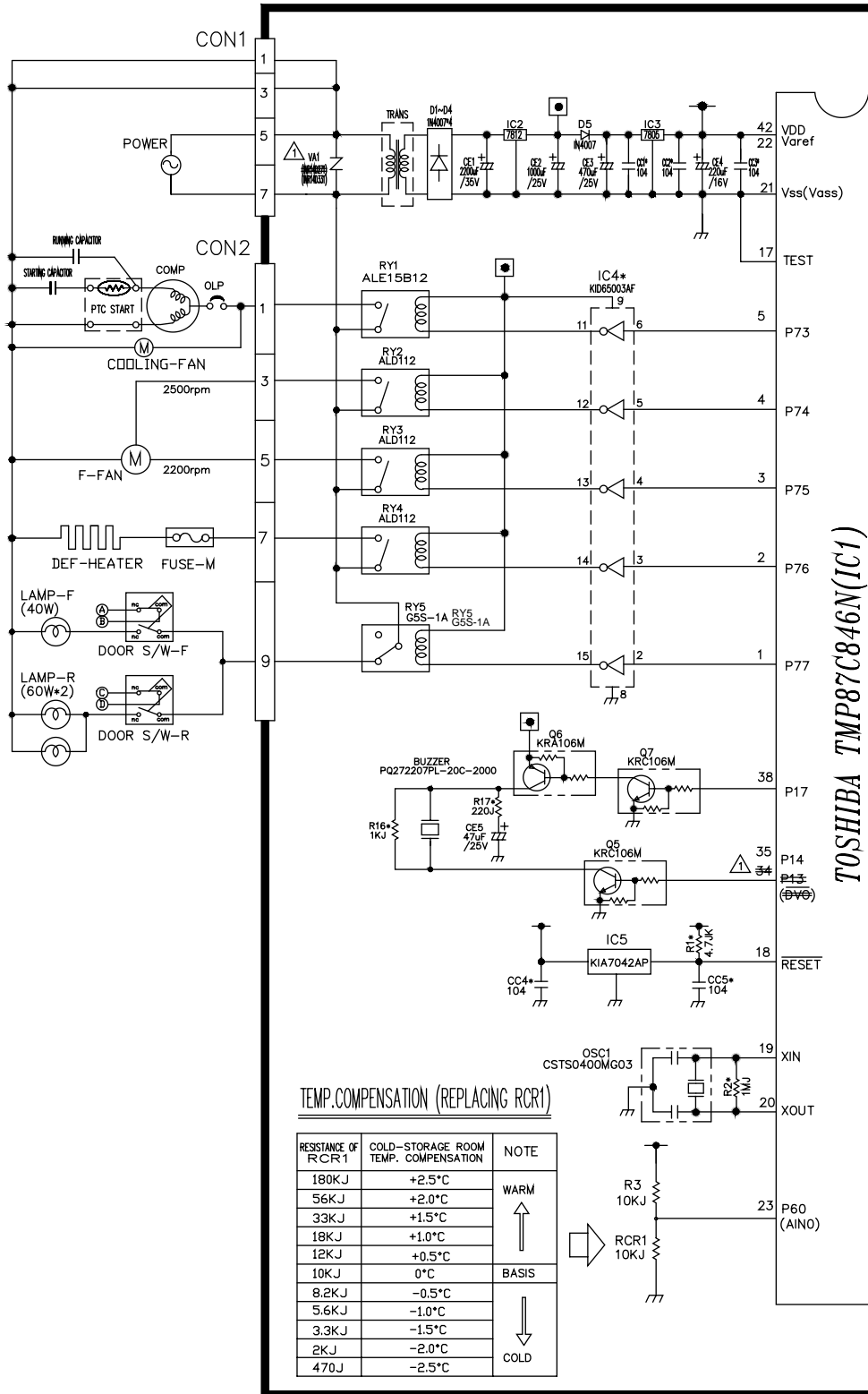

TOSHIBA TMP87C846N(IC1)

FIG.1 CIRCUIT DIAGRAM

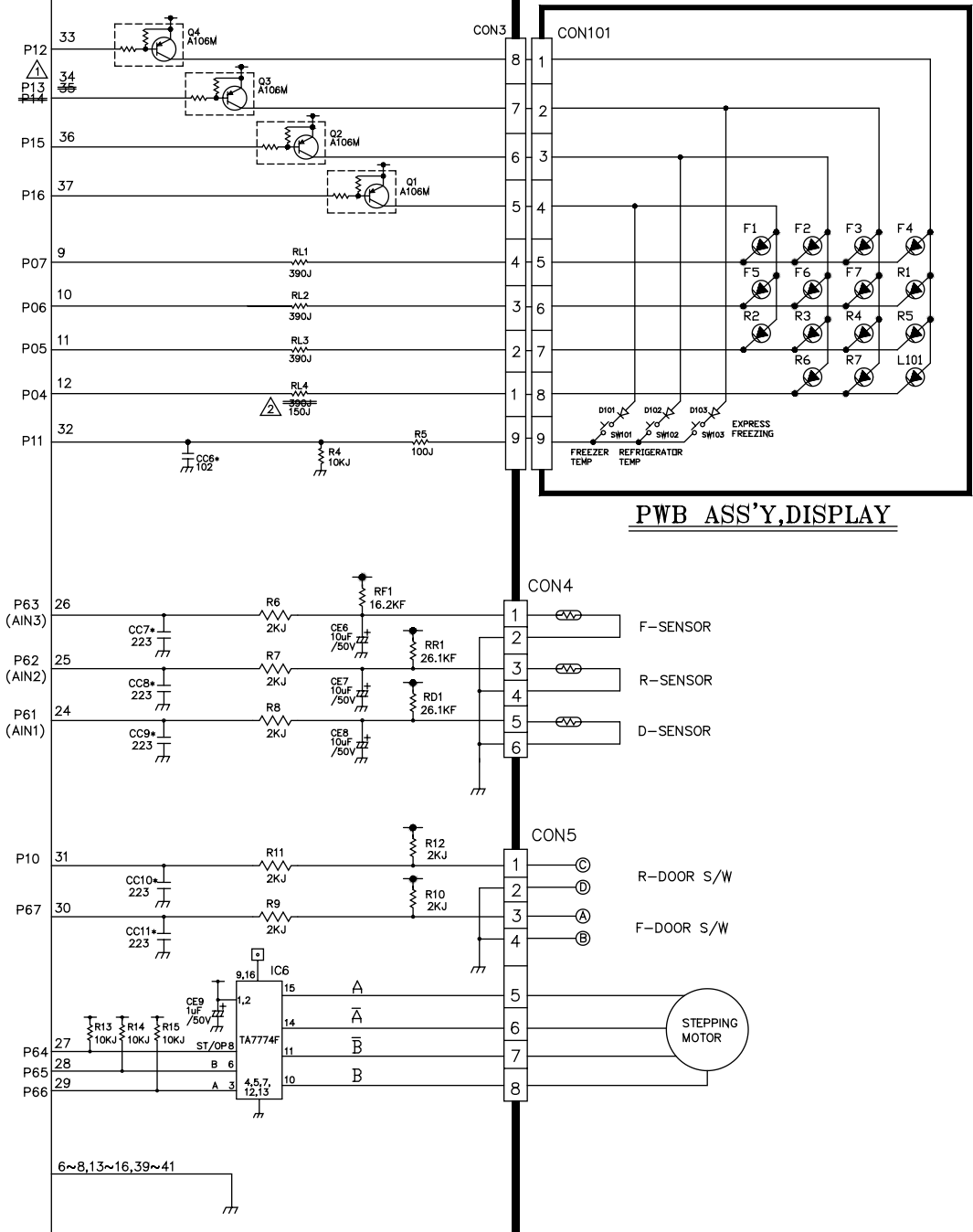

PWB ASS'Y, DISPLAY

FREEZER PARTS

CAUTION: Use the part number to order part, not the position number.

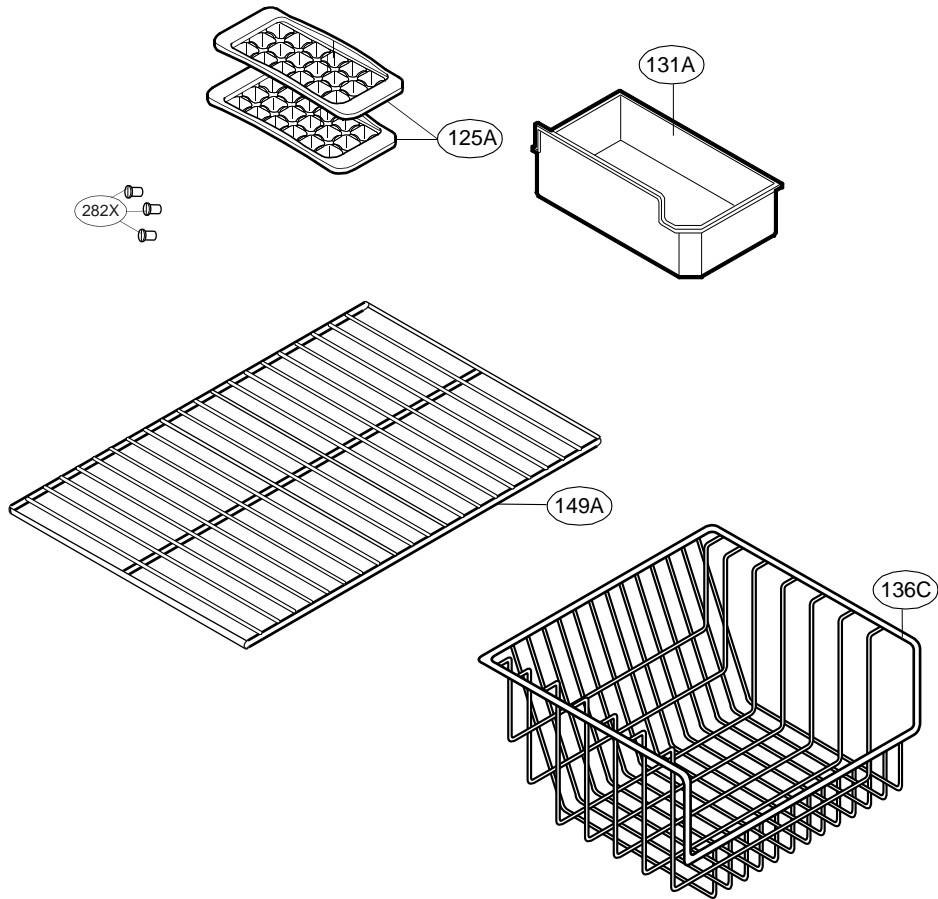

REFRIGERATOR PARTS

CAUTION: Use the part number to order part, not the position number.

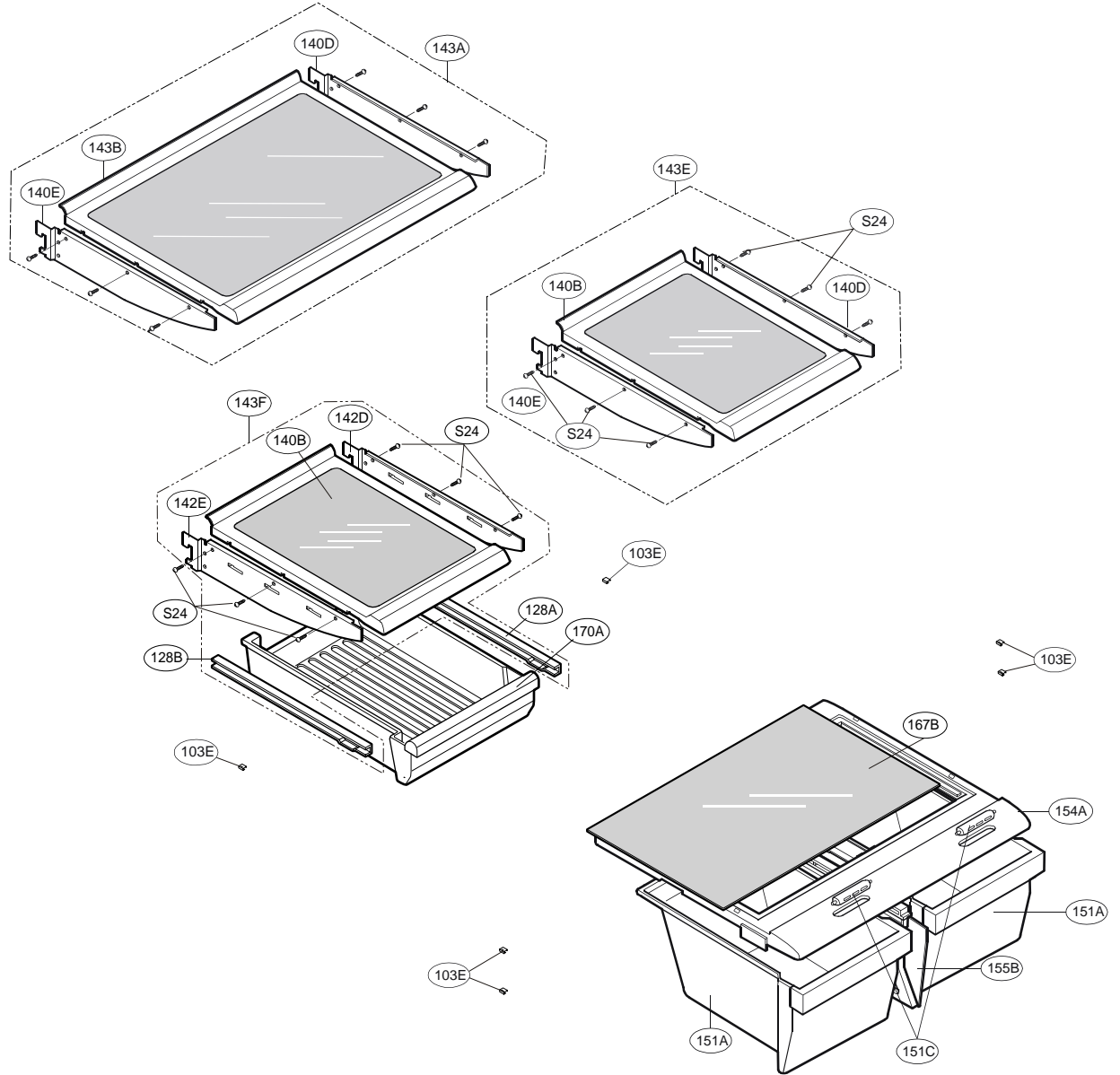

DOOR PARTS

CAUTION: Use the part number to order part, not the position number.

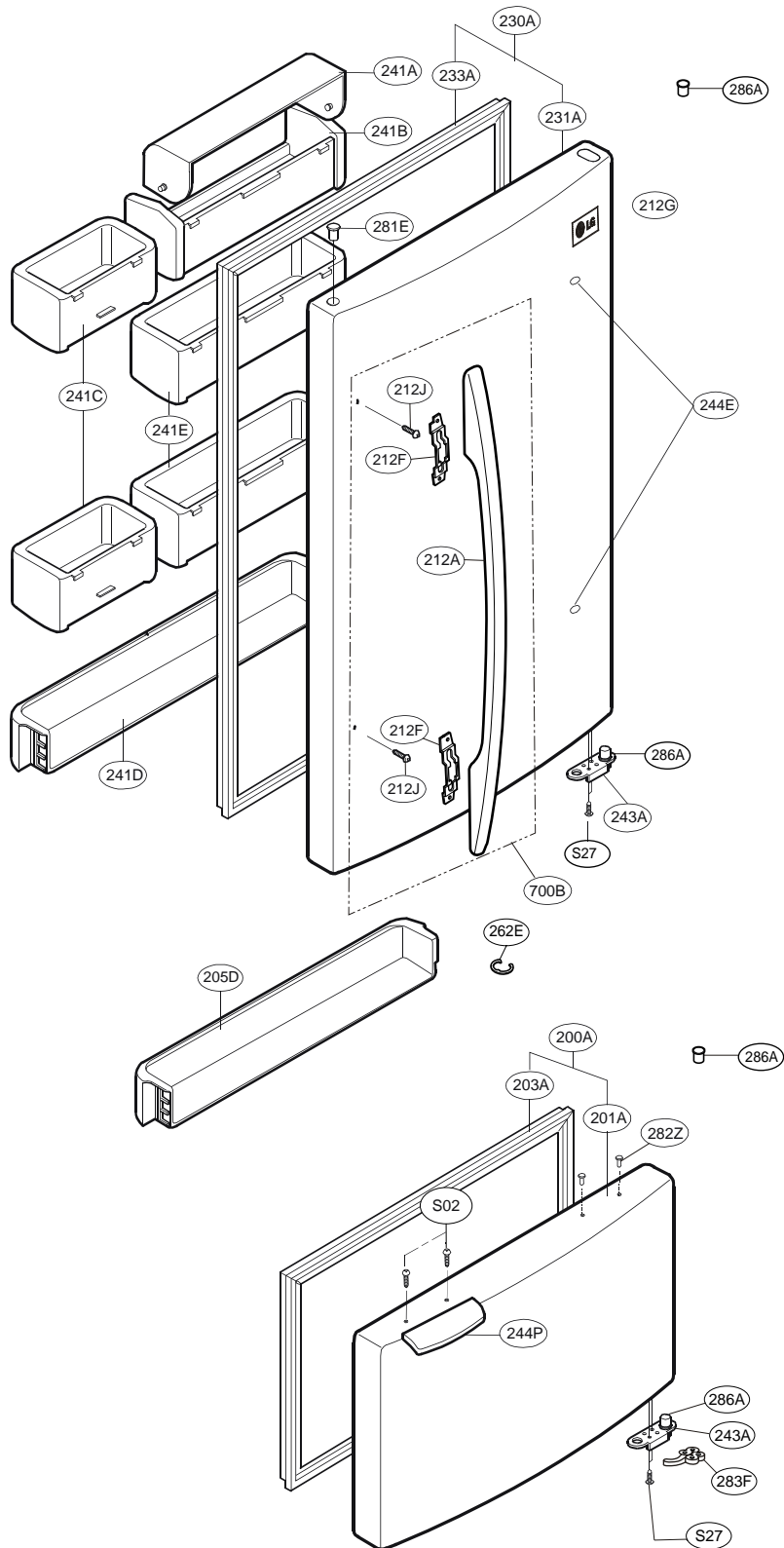

Loc No.	Part No.	Description	Loc No.	Part No.	Description
103A	3650JJ2003E	Handle,Rear	283B	4775JJ2007B	Hinge Assembly,Lower
103B	3650JJ2003A	Handle,Rear	283D	4774JJ2002A	Hinge,Lower
103C	3551JJ1015A	Cover Assembly,Lower	283F	MJB36873201	Stopper,Door
103E	5218JJ3001A	Rail,Slide	284B	3550JA3120A	Cover,Connector
105A	5251JA3003B	Tube Assembly,Drain	284D	1STZJA3004K	Screw,Customized
105F	5070JJ3002A	Skirt,Lower	284E	3550JJ3001A	Cover,Tube
106A	4779JA2003A	Leg Assembly,Adjust	286A	4984JJ3003A	BUSH
106B	4J00382C	Washer,Common	301A	5421JJ1001A	Evaporator Assembly
120B	5209JJ1002A	Duct Assembly,Multi	304A	3551JJ2008A	Cover Assembly,Machinery(Rear)
125A	3390JJ1023A	Tray,Ice	305B	4580JJ3001A	Roller
125D	4930JJ3007A	Holder,Bracket	305C	4J04238A	Pin,Common
128A	4975JJ2002A	Guide Assembly,Rail	307A	2521CRA5715	Compressor,Set Assembly
128B	4975JJ2002B	Guide Assembly,Rail	308A	EBG32606502	Thermistor Assembly,PTC
128E	4930JJ1012A	Holder,Rail	309A	6750C-0004S	Overload Protect
128F	4930JJ1012B	Holder,Rail	310A	3550JA2059A	Cover,PTC
131A	5074JJ1017A	Bucket,Ice	312A	5040JA3031A	Damper,Compressor
135C	3550JJ2030A	Cover,Grille Fan	314A	4620JA3009A	Stopper,Compressor
136C	3390JJ1058A	Tray,Drawer	315A	3103JJ1001K	Base Assembly,Compressor
140B	5027JJ2007A	Shelf Assembly,Refrigerator	317A	5851JJ2002F	Drier Assembly
140D	5026JJ2001G	Shelf,Net	318A	4930JA3034A	Holder,Drier
140E	5026JJ2001H	Shelf,Net	319A	3390JJ0003A	Tray,Drip
142D	5026JJ2001L	Shelf,Net	319C	4974JJ1009A	Guide,Fan
142E	5026JJ2001M	Shelf,Net	319E	4810JJ0002A	Bracket,Motor
143A	5027JJ1028A	Shelf Assembly,Refrigerator	323B	5403JJ1005A	Condenser Assembly,Wire
143B	5027JJ1015A	Shelf Assembly,Refrigerator	327A	5006JA3034A	Cap,Drain Tube
143E	5027JJ1008A	Shelf Assembly,Refrigerator	328A	4J03020A	Damper,Pipe
143F	5027JJ1008C	Shelf Assembly,Refrigerator	328A	4J03020A	Damper,Pipe
145A	4930JJ2003A	Holder,Shelf	328B	4J04328A	Damper,Pipe
145B	4930JJ2004A	Holder,Shelf	329A	5901JJ1005A	Fan Assembly
149A	5026JJ1058A	SHELF,FREEZER	329C	5901JJ1004B	Fan Assembly
151A	3390JJ1032A	Tray,Vegetable	332A	3531JJ1004B	Grille Assembly,Fan
151C	4940JJ2003A	Knob,Shutter	401A	6615JB2005C	Controller Assembly
154A	3550JL2001G	Cover,TV	404A	4680JK1002B	Motor, AC Freezing
155B	4981JJ2001B	Supporter Assembly,Cover TV	405A	4811JJ2002B	Bracket Assembly,Motor
158A	3550JJ1040A	Cover,Lamp	405B	4810JA3007A	Bracket,Motor
158E	MCK30060901	Cover,Lamp	405C	J756-00008B	Damper,Motor Support
167B	4890JL1002G	Shelf,Glass	406B	6600JB1010A	Switch,Push Button
170A	3391JJ2004G	Tray Assembly,Meat	409B	6912JK2002D	Lamp,Incandescent
200A	3581JJ8023A	Door Assembly,Freezer	409C	6912JK2002A	Lamp,Incandescent
201A	5433JJ0017E	Door Foam Assembly,Freezer	409D	3034JJ1002B	Reflector,Lamp
203A	4987JJ1004C	Gasket Assembly,Door	410A	6621JK2003B	Harness Assembly
205D	5004JJ1041A	Basket,Door	410G	0CZZJB2012J	Capacitor,Electric Appliance Film,Box
212A	3650JJ1031A	Handle,Refrigerator	411A	6411JK1006A	Power Cord Assembly
212F	4810JJ3015A	Bracket,Handle	418A	5300JB1100D	Heater,Sheath
212G	4140JD1031A	Name Plate	420A	4680JK1001B	Motor,AC
212J	4620JJ3007E	Stopper,Handle	501A	6871JB1215J	PCB Assembly,Main
230A	3581JJ8046B	Door Assembly,Refrigerator	501F	3551JJ1020A	Cover Assembly,PCB
231A	5433JJ0016N	Door Foam Assembly,Refrigerator	503C	6871JB2047A	PCB Assembly,Display
233A	4987JJ1004D	Gasket Assembly,Door	503D	3110JJ1005A	Case,Display
241A	3550JJ1024A	Cover,Tray	503E	3550JJ2031A	Cover,Display
241B	5004JJ1035A	Basket,Door	503F	ABQ33905307	Case Assembly,Display
241C	5004JJ1030A	Basket,Door	503G	3806JL1051A	Decor,Control
241D	5004JJ0002A	Basket,Door	610A	3550JJ2020A	Cover,Sensor
241E	5004JJ1028A	Basket,Door	619B	3550JJ2024A	Cover,Valve
243A	4620JJ3006A	Stopper,Door	623H	3550JJ2036A	Cover,Tube
244E	5006JJ3016A	Cap,Handle	700B	3651JJ2015A	Handle Assembly,Refrigerator
244P	3650JJ2012A	Handle,Freezer	903A	3550JJ0005A	Cover,Lower
262E	4350JA3005B	Ring	903B	4930JJ2021A	Holder,Cover(Lower)
281A	3550JJ2013A	Cover,Hinge	903D	6500JK1003A	Sensor
281B	4775JJ2003B	Hinge Assembly,Upper	903E	6500JK1004A	Sensor
281E	5006JJ3014A	Cap,Hinge	B01	1STZJA3004F	Screw,Customized
282B	4775JJ8002F	Hinge Assembly,Center	S01	1SZZJJ3010A	Screw,Customized
282C	1PZZJJ3002F	Pin,Common	S02	1SZZJJ3010B	Screw,Customized
282E	5006JJ2001A	Cap,Hinge	S22	J471-00001J	Screw,Customized
282F	3806JL2006D	Decor,Duct	S24	1SZZJA3011B	Screw,Customized
282H	5006JJ3004A	Cap,Hinge	S27	4J01424C	Screw,Customized
282X	5006JJ3010A	Cap,Handle	S38	4J00415D	Screw,Customized
282Z	5006JJ3010A	Cap,Handle			

Loc No.	Part No.	Description	Loc No.	Part No.	Description
103A	3650JJ2003F	Handle,Rear	283B	4775JJ2007B	Hinge Assembly,Lower
103B	3650JJ2003B	Handle,Rear	283D	4774JJ2002A	Hinge,Lower
103C	3551JJ1015C	Cover Assembly,Lower	283F	MJB36873201	Stopper,Door
103E	5218JJ3001A	Rail,Slide	284B	3550JA3120A	Cover,Connector
105A	5251JA3003B	Tube Assembly,Drain	284D	1STZJA3004K	Screw,Customized
105F	5070JJ3002A	Skirt,Lower	284E	3550JJ3001A	Cover,Tube
106A	4779JA2003A	Leg Assembly,Adjust	286A	4984JJ3003A	BUSH
106B	4J00382C	Washer,Common	301A	5421JJ1001A	Evaporator Assembly
120B	5209JJ1002A	Duct Assembly,Multi	304A	3551JJ2008A	Cover Assembly,Machinery(Rear)
125A	3390JJ1023A	Tray,Ice	305B	4580JJ3001A	Roller
125D	4930JJ3007A	Holder,Bracket	305C	4J04238A	Pin,Common
128A	4975JJ2002A	Guide Assembly,Rail	307A	2521CRA5715	Compressor,Set Assembly
128B	4975JJ2002B	Guide Assembly,Rail	308A	EBG32606502	Thermistor Assembly,PTC
128E	4930JJ1012A	Holder,Rail	309A	6750C-0004S	Overload Protect
128F	4930JJ1012B	Holder,Rail	310A	3550JA2059A	Cover,PTC
131A	5074JJ1017A	Bucket,Ice	312A	5040JA3031A	Damper,Compressor
135C	3550JJ2030A	Cover,Grille Fan	314A	4620JA3009A	Stopper,Compressor
136C	3390JJ1058A	Tray,Drawer	315A	3103JJ1001K	Base Assembly,Compressor
140B	5027JJ2007A	Shelf Assembly,Refrigerator	317A	5851JJ2002F	Drier Assembly
140D	5026JJ2001G	Shelf,Net	318A	4930JA3034A	Holder,Drier
140E	5026JJ2001H	Shelf,Net	319A	3390JJ0003A	Tray,Drip
142D	5026JJ2001L	Shelf,Net	319C	4974JJ1009A	Guide,Fan
142E	5026JJ2001M	Shelf,Net	319E	4810JJ0002A	Bracket,Motor
143A	5027JJ1028A	Shelf Assembly,Refrigerator	323B	5403JJ1005A	Condenser Assembly,Wire
143B	5027JJ1015A	Shelf Assembly,Refrigerator	327A	5006JA3034A	Cap,Drain Tube
143E	5027JJ1008A	Shelf Assembly,Refrigerator	328A	4J03020A	Damper,Pipe
143F	5027JJ1008C	Shelf Assembly,Refrigerator	328A	4J03020A	Damper,Pipe
145A	4930JJ2003A	Holder,Shelf	328B	4J04328A	Damper,Pipe
145B	4930JJ2004A	Holder,Shelf	329A	5901JJ1005A	Fan Assembly
149A	5026JJ1058A	SHELF,FREEZER	329C	5901JJ1004B	Fan Assembly
151A	3390JJ1032A	Tray,Vegetable	332A	3531JJ1004B	Grille Assembly,Fan
151C	4940JJ2003A	Knob,Shutter	401A	6615JB2005C	Controller Assembly
154A	3550JL2001G	Cover,TV	404A	4680JK1002B	Motor, AC Freezing
155B	4981JJ2001B	Supporter Assembly,Cover TV	405A	4811JJ2002B	Bracket Assembly,Motor
158A	3550JJ1040A	Cover,Lamp	405B	4810JA3007A	Bracket,Motor
158E	MCK30060901	Cover,Lamp	405C	J756-00008B	Damper,Motor Support
167B	4890JL1002G	Shelf,Glass	406B	6600JB1010A	Switch,Push Button
170A	3391JJ2004G	Tray Assembly,Meat	409B	6912JK2002D	Lamp,Incandescent
200A	3581JJ8023E	Door Assembly,Freezer	409C	6912JK2002A	Lamp,Incandescent
201A	5433JJ0017K	Door Foam Assembly,Freezer	409D	3034JJ1002B	Reflector,Lamp
203A	4987JJ1004C	Gasket Assembly,Door	410A	6621JK2003B	Harness Assembly
205D	5004JJ1041A	Basket,Door	410G	0CZZJB2012J	Capacitor,Electric Appliance Film,Box
212A	3650JJ1031C	Handle,Refrigerator	411A	6411JK1006A	Power Cord Assembly
212F	4810JJ3015A	Bracket,Handle	418A	5300JB1100D	Heater,Sheath
212G	4140JD1031A	Name Plate	420A	4680JK1001B	Motor,AC
212J	4620JJ3007E	Stopper,Handle	501A	6871JB1215J	PCB Assembly,Main
230A	3581JJ8046A	Door Assembly,Refrigerator	501F	3551JJ1020A	Cover Assembly,PCB
231A	5433JJ0016Q	Door Foam Assembly,Refrigerator	503C	6871JB2047A	PCB Assembly,Display
233A	4987JJ1004D	Gasket Assembly,Door	503D	3110JJ1005A	Case,Display
241A	3550JJ1024A	Cover,Tray	503E	3550JJ2031A	Cover,Display
241B	5004JJ1035A	Basket,Door	503F	ABQ33905307	Case Assembly,Display
241C	5004JJ1030A	Basket,Door	503G	3806JL1051A	Decor,Control
241D	5004JJ0002A	Basket,Door	610A	3550JJ2020A	Cover,Sensor
241E	5004JJ1028A	Basket,Door	619B	3550JJ2024A	Cover,Valve
243A	4620JJ3006B	Stopper,Door	623H	3550JJ2036A	Cover,Tube
244E	5006JJ3016B	Cap,Handle	700B	3651JJ2015C	Handle Assembly,Refrigerator
244P	3650JJ2012C	Handle,Freezer	903A	3550JJ0005B	Cover,Lower
262E	4350JA3005B	Ring	903B	4930JJ2021A	Holder,Cover(Lower)
281A	3550JJ2013B	Cover,Hinge	903D	6500JK1003A	Sensor
281B	4775JJ2003B	Hinge Assembly,Upper	903E	6500JK1004A	Sensor
281E	5006JJ3014B	Cap,Hinge	B01	1STZJA3004F	Screw,Customized
282B	4775JJ8002D	Hinge Assembly,Center	S01	1SZZJJ3010A	Screw,Customized
282C	1PZZJJ3002F	Pin,Common	S02	1SZZJJ3010E	Screw,Customized
282E	5006JJ2001E	Cap,Hinge	S22	J471-00001J	Screw,Customized
282F	3806JL2006D	Decor,Duct	S24	1SZZJA3011B	Screw,Customized
282H	5006JJ3004D	Cap,Hinge	S27	4J01424C	Screw,Customized
282X	5006JJ3010A	Cap,Handle	S38	4J00415D	Screw,Customized
282Z	5006JJ3010B	Cap,Handle			

Loc No.	Part No.	Description	Loc No.	Part No.	Description
103A	3650JJ2003M	Handle,Rear	283B	4775JJ2007B	Hinge Assembly,Lower
103B	3650JJ2003L	Handle,Rear	283D	4774JJ2002A	Hinge,Lower
103C	3551JJ1015E	Cover Assembly,Lower	283F	MJB36873202	Stopper,Door
103E	5218JJ3001A	Rail,Slide	284B	3550JA3120A	Cover,Connector
105A	5251JA3003B	Tube Assembly,Drain	284D	1STZJA3004K	Screw,Customized
105F	5070JJ3002A	Skirt,Lower	284E	3550JJ3001A	Cover,Tube
106A	4779JA2003A	Leg Assembly,Adjust	286A	4984JJ3003A	BUSH
106B	4J00382C	Washer,Common	301A	5421JJ1001A	Evaporator Assembly
120B	5209JJ1002A	Duct Assembly,Multi	304A	3551JJ2008A	Cover Assembly,Machinery(Rear)
125A	3390JJ1023A	Tray,Ice	305B	4580JJ3001A	Roller
125D	4930JJ3007A	Holder,Bracket	305C	4J04238A	Pin,Common
128A	4975JJ2002A	Guide Assembly,Rail	307A	2521CRA5715	Compressor,Set Assembly
128B	4975JJ2002B	Guide Assembly,Rail	308A	EBG32606502	Thermistor Assembly,PTC
128E	4930JJ1012A	Holder,Rail	309A	6750C-0004S	Overload Protect
128F	4930JJ1012B	Holder,Rail	310A	3550JA2059A	Cover,PTC
131A	5074JJ1017A	Bucket,Ice	312A	5040JA3031A	Damper,Compressor
135C	3550JJ2030A	Cover,Grille Fan	314A	4620JA3009A	Stopper,Compressor
136C	3390JJ1058A	Tray,Drawer	315A	3103JJ1001K	Base Assembly,Compressor
140B	5027JJ2007A	Shelf Assembly,Refrigerator	317A	5851JJ2002F	Drier Assembly
140D	5026JJ2001G	Shelf,Net	318A	4930JA3034A	Holder,Drier
140E	5026JJ2001H	Shelf,Net	319A	3390JJ0003A	Tray,Drip
142D	5026JJ2001L	Shelf,Net	319C	4974JJ1009A	Guide,Fan
142E	5026JJ2001M	Shelf,Net	319E	4810JJ0002A	Bracket,Motor
143A	5027JJ1028A	Shelf Assembly,Refrigerator	323B	5403JJ1005A	Condenser Assembly,Wire
143B	5027JJ1015A	Shelf Assembly,Refrigerator	327A	5006JA3034A	Cap,Drain Tube
143E	5027JJ1008A	Shelf Assembly,Refrigerator	328A	4J03020A	Damper,Pipe
143F	5027JJ1008C	Shelf Assembly,Refrigerator	328A	4J03020A	Damper,Pipe
145A	4930JJ2003A	Holder,Shelf	328B	4J04328A	Damper,Pipe
145B	4930JJ2004A	Holder,Shelf	329A	5901JJ1005A	Fan Assembly
149A	5026JJ1058A	SHELF,FREEZER	329C	5901JJ1004B	Fan Assembly
151A	3390JJ1032A	Tray,Vegetable	332A	3531JJ1004B	Grille Assembly,Fan
151C	4940JJ2003A	Knob,Shutter	401A	6615JB2005C	Controller Assembly
154A	3550JL2001G	Cover,TV	404A	4680JK1002B	Motor, AC Freezing
155B	4981JJ2001B	Supporter Assembly,Cover TV	405A	4811JJ2002B	Bracket Assembly,Motor
158A	3550JJ1040A	Cover,Lamp	405B	4810JA3007A	Bracket,Motor
158E	MCK30060901	Cover,Lamp	405C	J756-00008B	Damper,Motor Support
167B	4890JL1002G	Shelf,Glass	406B	6600JB1010A	Switch,Push Button
170A	3391JJ2004G	Tray Assembly,Meat	409B	6912JK2002D	Lamp,Incandescent
200A	3581JJ8023F	Door Assembly,Freezer	409C	6912JK2002A	Lamp,Incandescent
201A	5433JJ0017P	Door Foam Assembly,Freezer	409D	3034JJ1002B	Reflector,Lamp
203A	4987JJ1004G	Gasket Assembly,Door	410A	6621JK2003B	Harness Assembly
205D	5004JJ1041A	Basket,Door	410G	0CZZJB2012J	Capacitor,Electric Appliance Film,Box
212A	3650JJ1031B	Handle,Refrigerator	411A	6411JK1006A	Power Cord Assembly
212F	4810JJ3015A	Bracket,Handle	418A	5300JB1100D	Heater,Sheath
212G	4140JL2001C	NAME PLATE	420A	4680JK1001B	Motor,AC
212J	4620JJ3007E	Stopper,Handle	501A	6871JB1215J	PCB Assembly,Main
230A	3581JJ8046C	Door Assembly,Refrigerator	501F	3551JJ1020A	Cover Assembly,PCB
231A	5433JJ0016S	Door Foam Assembly,Refrigerator	503C	6871JB2047A	PCB Assembly,Display
233A	4987JJ1004H	Gasket Assembly,Door	503D	3110JJ1005A	Case,Display
241A	3550JJ1024A	Cover,Tray	503E	3550JJ2031A	Cover,Display
241B	5004JJ1035A	Basket,Door	503F	ABQ33905307	Case Assembly,Display
241C	5004JJ1030A	Basket,Door	503G	3806JL1051A	Decor,Control
241D	5004JJ0002A	Basket,Door	610A	3550JJ2020A	Cover,Sensor
241E	5004JJ1028A	Basket,Door	619B	3550JJ2024A	Cover,Valve
243A	4620JJ3006C	Stopper,Door	623H	3550JJ2036A	Cover,Tube
244E	5006JJ3016C	Cap,Handle	700B	3651JJ2015B	Handle Assembly,Refrigerator
244P	3650JJ2012B	Handle,Freezer	903A	3550JJ0005C	Cover,Lower
262E	4350JA3005B	Ring	903B	4930JJ2021A	Holder,Cover(Lower)
281A	3550JJ2013C	Cover,Hinge	903D	6500JK1003A	Sensor
281B	4775JJ2003B	Hinge Assembly,Upper	903E	6500JK1004A	Sensor
281E	5006JJ3014C	Cap,Hinge	B01	1STZJA3004F	Screw,Customized
282B	4775JJ8002E	Hinge Assembly,Center	S01	1SZZJJ3010A	Screw,Customized
282C	1PZZJJ3002F	Pin,Common	S02	1SZZJJ3010D	Screw,Customized
282E	5006JJ2001F	Cap,Hinge	S22	J471-00001J	Screw,Customized
282F	3806JL2006D	Decor,Duct	S24	1SZZJA3011B	Screw,Customized
282H	5006JJ3004E	Cap,Hinge	S27	4J01424C	Screw,Customized
282X	5006JJ3010A	Cap,Handle	S38	4J00415D	Screw,Customized
282Z	5006JJ3010C	Cap,Handle			

Loc No.	Part No.	Description	Loc No.	Part No.	Description
103A	3650JJ2003E	Handle,Rear	282X	5006JJ3010A	Cap,Handle
103B	3650JJ2003A	Handle,Rear	282Z	5006JJ3010A	Cap,Handle
103C	3551JJ1015A	Cover Assembly,Lower	283B	4775JJ2007B	Hinge Assembly,Lower
103E	5218JJ3001A	Rail,Slide	283D	4774JJ2002A	Hinge,Lower
105A	5251JA3003B	Tube Assembly,Drain	283F	MJB36873201	Stopper,Door
105F	5070JJ3002A	Skirt,Lower	284B	3550JA3120A	Cover,Connector
106A	4779JA2003A	Leg Assembly,Adjust	284D	1STZJA3004K	Screw,Customized
106B	4J00382C	Washer,Common	284E	3550JJ3001A	Cover,Tube
120B	5209JJ1002A	Duct Assembly,Multi	286A	4984JJ3003A	BUSH
125A	3390JJ1023A	Tray,Ice	301A	5421JJ1001A	Evaporator Assembly
125D	4930JJ3007A	Holder,Bracket	304A	3551JJ2008A	Cover Assembly,Machinery(Rear)
128A	4975JJ2002A	Guide Assembly,Rail	305B	4580JJ3001A	Roller
128B	4975JJ2002B	Guide Assembly,Rail	305C	4J04238A	Pin,Common
128E	4930JJ1012A	Holder,Rail	307A	2521CRA5715	Compressor,Set Assembly
128F	4930JJ1012B	Holder,Rail	308A	EBG32606502	Thermistor Assembly,PTC
131A	5074JJ1017A	Bucket,Ice	309A	6750C-0004S	Overload Protect
135C	3550JJ2030A	Cover,Grille Fan	310A	3550JA2059A	Cover,PTC
136C	3390JJ1058A	Tray,Drawer	312A	5040JA3031A	Damper,Compressor
140B	5027JJ2007A	Shelf Assembly,Refrigerator	314A	4620JA3009A	Stopper,Compressor
140D	MHL38615403	Shelf,Net	315A	3103JJ1001K	Base Assembly,Compressor
140E	MHL38615404	Shelf,Net	317A	5851JJ2002F	Drier Assembly
142D	5026JJ2001L	Shelf,Net	318A	4930JA3034A	Holder,Drier
142E	5026JJ2001M	Shelf,Net	319A	3390JJ0003A	Tray,Drip
143A	5027JJ1028E	Shelf Assembly,Refrigerator	319C	4974JJ1009A	Guide,Fan
143B	5027JJ1015A	Shelf Assembly,Refrigerator	319E	4810JJ0002A	Bracket,Motor
143E	5027JJ1008J	Shelf Assembly,Refrigerator	323B	5403JJ1005A	Condenser Assembly,Wire
143F	5027JJ1008C	Shelf Assembly,Refrigerator	327A	5006JA3034A	Cap,Drain Tube
145A	4930JJ2003A	Holder,Shelf	328A	4J03020A	Damper,Pipe
145B	4930JJ2004A	Holder,Shelf	328B	4J04328A	Damper,Pipe
146A	5047JJ1001A	Case,Lower	329A	5901JJ1005A	Fan Assembly
149A	5026JJ1058A	SHELF,FREEZER	329C	5901JJ1004B	Fan Assembly
151A	3390JJ1032A	Tray,Vegetable	332A	3531JJ1004B	Grille Assembly,Fan
151C	4940JJ2003A	Knob,Shutter	401A	6615JB2005C	Controller Assembly
154A	3550JL2001G	Cover,TV	404A	4680JK1002B	Motor, AC Freezing
155B	4981JJ2001B	Supporter Assembly,Cover TV	405A	4811JJ2002B	Bracket Assembly,Motor
158A	3550JJ1040A	Cover,Lamp	405B	4810JA3007A	Bracket,Motor
158E	MCK30060901	Cover,Lamp	405C	J756-00008B	Damper,Motor Support
167B	4890JL1002G	Shelf,Glass	406B	6600JB1010A	Switch,Push Button
170A	3391JJ2004G	Tray Assembly,Meat	409B	6912JK2002D	Lamp,Incandescent
200A	3581JJ8023A	Door Assembly,Freezer	409C	6912JK2002A	Lamp,Incandescent
201A	5433JJ0017E	Door Foam Assembly,Freezer	409D	3034JJ1002B	Reflector,Lamp
203A	4987JJ1004C	Gasket Assembly,Door	410A	6621JK2003B	Harness Assembly
205D	5004JJ1041A	Basket,Door	410G	0CZZJB2012J	Capacitor,Electric Appliance Film,Box
212A	3650JJ1031A	Handle,Refrigerator	411A	6411JK1006A	Power Cord Assembly
212F	4810JJ3015A	Bracket,Handle	418A	5300JB1100D	Heater,Sheath
212G	4140JD1031A	Name Plate	420A	4680JK1001B	Motor,AC
212J	4620JJ3007E	Stopper,Handle	501A	6871JB1215J	PCB Assembly,Main
230A	3581JJ8046B	Door Assembly,Refrigerator	501F	3551JJ1020A	Cover Assembly,PCB
231A	5433JJ0016N	Door Foam Assembly,Refrigerator	503C	6871JB2047A	PCB Assembly,Display
233A	4987JJ1004D	Gasket Assembly,Door	503D	3110JJ1005A	Case,Display
241A	3550JJ1024A	Cover,Tray	503E	3550JJ2031A	Cover,Display
241B	5004JJ1035A	Basket,Door	503F	ABQ33905307	Case Assembly,Display
241C	5004JJ1030A	Basket,Door	503G	3806JL1051A	Decor,Control
241D	5004JJ0002A	Basket,Door	610A	3550JJ2020A	Cover,Sensor
241E	5004JJ1028A	Basket,Door	619B	3550JJ2024A	Cover,Valve
243A	4620JJ3006A	Stopper,Door	623H	3550JJ2036A	Cover,Tube
244E	5006JJ3016A	Cap,Handle	700B	3651JJ2015A	Handle Assembly,Refrigerator
244E	5006JJ3016A	Cap,Handle	903A	3550JJ0005A	Cover,Lower
244P	3650JJ2012A	Handle,Freezer	903B	4930JJ2021A	Holder,Cover(Lower)
262E	4350JA3005B	Ring	903D	6500JK1003A	Sensor
281A	3550JJ2013A	Cover,Hinge	903E	6500JK1004A	Sensor
281B	4775JJ2003B	Hinge Assembly,Upper	B01	1STZJA3004F	Screw,Customized
281E	5006JJ3014A	Cap,Hinge	S01	1SZZJJ3010A	Screw,Customized
282B	4775JJ8002F	Hinge Assembly,Center	S02	1SZZJJ3010B	Screw,Customized
282C	1PZZJJ3002F	Pin,Common	S22	J471-00001J	Screw,Customized
282E	5006JJ2001A	Cap,Hinge	S24	1SZZJA3011B	Screw,Customized
282F	3806JL2006D	Decor,Duct	S27	4J01424C	Screw,Customized
282H	5006JJ3004A	Cap,Hinge	S38	4J00415D	Screw,Customized

Loc No.	Part No.	Description	Loc No.	Part No.	Description
103A	3650JJ2003F	Handle,Rear	282X	5006JJ3010A	Cap,Handle
103B	3650JJ2003B	Handle,Rear	282Z	5006JJ3010B	Cap,Handle
103C	3551JJ1015C	Cover Assembly,Lower	283B	4775JJ2007B	Hinge Assembly,Lower
103E	5218JJ3001A	Rail,Slide	283D	4774JJ2002A	Hinge,Lower
105A	5251JA3003B	Tube Assembly,Drain	283F	MJB36873201	Stopper,Door
105F	5070JJ3002A	Skirt,Lower	284B	3550JA3120A	Cover,Connector
106A	4779JA2003A	Leg Assembly,Adjust	284D	1STZJA3004K	Screw,Customized
106B	4J00382C	Washer,Common	284E	3550JJ3001A	Cover,Tube
120B	5209JJ1002A	Duct Assembly,Multi	286A	4984JJ3003A	BUSH
125A	3390JJ1023A	Tray,Ice	301A	5421JJ1001A	Evaporator Assembly
125D	4930JJ3007A	Holder,Bracket	304A	3551JJ2008A	Cover Assembly,Machinery(Rear)
128A	4975JJ2002A	Guide Assembly,Rail	305B	4580JJ3001A	Roller
128B	4975JJ2002B	Guide Assembly,Rail	305C	4J04238A	Pin,Common
128E	4930JJ1012A	Holder,Rail	307A	2521CRA5715	Compressor,Set Assembly
128F	4930JJ1012B	Holder,Rail	308A	EBG32606502	Thermistor Assembly,PTC
131A	5074JJ1017A	Bucket,Ice	309A	6750C-0004S	Overload Protect
135C	3550JJ2030A	Cover,Grille Fan	310A	3550JA2059A	Cover,PTC
136C	3390JJ1058A	Tray,Drawer	312A	5040JA3031A	Damper,Compressor
140B	5027JJ2007A	Shelf Assembly,Refrigerator	314A	4620JA3009A	Stopper,Compressor
140D	MHL38615403	Shelf,Net	315A	3103JJ1001K	Base Assembly,Compressor
140E	MHL38615404	Shelf,Net	317A	5851JJ2002F	Drier Assembly
142D	5026JJ2001L	Shelf,Net	318A	4930JA3034A	Holder,Drier
142E	5026JJ2001M	Shelf,Net	319A	3390JJ0003A	Tray,Drip
143A	5027JJ1028E	Shelf Assembly,Refrigerator	319C	4974JJ1009A	Guide,Fan
143B	5027JJ1015A	Shelf Assembly,Refrigerator	319E	4810JJ0002A	Bracket,Motor
143E	5027JJ1008J	Shelf Assembly,Refrigerator	323B	5403JJ1005A	Condenser Assembly,Wire
143F	5027JJ1008C	Shelf Assembly,Refrigerator	327A	5006JA3034A	Cap,Drain Tube
145A	4930JJ2003A	Holder,Shelf	328A	4J03020A	Damper,Pipe
145B	4930JJ2004A	Holder,Shelf	328B	4J04328A	Damper,Pipe
146A	5047JJ1001A	Case,Lower	329A	5901JJ1005A	Fan Assembly
149A	5026JJ1058A	SHELF,FREEZER	329C	5901JJ1004B	Fan Assembly
151A	3390JJ1032A	Tray,Vegetable	332A	3531JJ1004B	Grille Assembly,Fan
151C	4940JJ2003A	Knob,Shutter	401A	6615JB2005C	Controller Assembly
154A	3550JL2001G	Cover,TV	404A	4680JK1002B	Motor, AC Freezing
155B	4981JJ2001B	Supporter Assembly,Cover TV	405A	4811JJ2002B	Bracket Assembly,Motor
158A	3550JJ1040A	Cover,Lamp	405B	4810JA3007A	Bracket,Motor
158E	MCK30060901	Cover,Lamp	405C	J756-00008B	Damper,Motor Support
167B	4890JL1002G	Shelf,Glass	406B	6600JB1010A	Switch,Push Button
170A	3391JJ2004G	Tray Assembly,Meat	409B	6912JK2002D	Lamp,Incandescent
200A	3581JJ8023E	Door Assembly,Freezer	409C	6912JK2002A	Lamp,Incandescent
201A	5433JJ0017K	Door Foam Assembly,Freezer	409D	3034JJ1002B	Reflector,Lamp
203A	4987JJ1004C	Gasket Assembly,Door	410A	6621JK2003B	Harness Assembly
205D	5004JJ1041A	Basket,Door	410G	0CZZJB2012J	Capacitor,Electric Appliance Film,Box
212A	3650JJ1031C	Handle,Refrigerator	411A	6411JK1006A	Power Cord Assembly
212F	4810JJ3015A	Bracket,Handle	418A	5300JB1100D	Heater,Sheath
212G	4140JD1031A	Name Plate	420A	4680JK1001B	Motor,AC
212J	4620JJ3007E	Stopper,Handle	501A	6871JB1215J	PCB Assembly,Main
230A	3581JJ8046A	Door Assembly,Refrigerator	501F	3551JJ1020A	Cover Assembly,PCB
231A	5433JJ0016Q	Door Foam Assembly,Refrigerator	503C	6871JB2047A	PCB Assembly,Display
233A	4987JJ1004D	Gasket Assembly,Door	503D	3110JJ1005A	Case,Display
241A	3550JJ1024A	Cover,Tray	503E	3550JJ2031A	Cover,Display
241B	5004JJ1035A	Basket,Door	503F	ABQ33905307	Case Assembly,Display
241C	5004JJ1030A	Basket,Door	503G	3806JL1051A	Decor,Control
241D	5004JJ0002A	Basket,Door	610A	3550JJ2020A	Cover,Sensor
241E	5004JJ1028A	Basket,Door	619B	3550JJ2024A	Cover,Valve
243A	4620JJ3006B	Stopper,Door	623H	3550JJ2036A	Cover,Tube
244E	5006JJ3016B	Cap,Handle	700B	3651JJ2015C	Handle Assembly,Refrigerator
244E	5006JJ3016B	Cap,Handle	903A	3550JJ0005B	Cover,Lower
244P	3650JJ2012C	Handle,Freezer	903B	4930JJ2021A	Holder,Cover(Lower)
262E	4350JA3005B	Ring	903D	6500JK1003A	Sensor
281A	3550JJ2013B	Cover,Hinge	903E	6500JK1004A	Sensor
281B	4775JJ2003B	Hinge Assembly,Upper	B01	1STZJA3004F	Screw,Customized
281E	5006JJ3014B	Cap,Hinge	S01	1SZZJJ3010A	Screw,Customized
282B	4775JJ8002D	Hinge Assembly,Center	S02	1SZZJJ3010E	Screw,Customized
282C	1PZZJJ3002F	Pin,Common	S22	J471-00001J	Screw,Customized
282E	5006JJ2001E	Cap,Hinge	S24	1SZZJA3011B	Screw,Customized
282F	3806JL2006D	Decor,Duct	S27	4J01424C	Screw,Customized
282H	5006JJ3004D	Cap,Hinge	S38	4J00415D	Screw,Customized

Loc No.	Part No.	Description	Loc No.	Part No.	Description
103A	3650JJ2003M	Handle,Rear	282X	5006JJ3010A	Cap,Handle
103B	3650JJ2003L	Handle,Rear	282Z	5006JJ3010C	Cap,Handle
103C	3551JJ1015E	Cover Assembly,Lower	283B	4775JJ2007B	Hinge Assembly,Lower
103E	5218JJ3001A	Rail,Slide	283D	4774JJ2002A	Hinge,Lower
105A	5251JA3003B	Tube Assembly,Drain	283F	MJB36873202	Stopper,Door
105F	5070JJ3002A	Skirt,Lower	284B	3550JA3120A	Cover,Connector
106A	4779JA2003A	Leg Assembly,Adjust	284D	1STZJA3004K	Screw,Customized
106B	4J00382C	Washer,Common	284E	3550JJ3001A	Cover,Tube
120B	5209JJ1002A	Duct Assembly,Multi	286A	4984JJ3003A	BUSH
125A	3390JJ1023A	Tray,Ice	301A	5421JJ1001A	Evaporator Assembly
125D	4930JJ3007A	Holder,Bracket	304A	3551JJ2008A	Cover Assembly,Machinery(Rear)
128A	4975JJ2002A	Guide Assembly,Rail	305B	4580JJ3001A	Roller
128B	4975JJ2002B	Guide Assembly,Rail	305C	4J04238A	Pin,Common
128E	4930JJ1012A	Holder,Rail	307A	2521CRA5715	Compressor,Set Assembly
128F	4930JJ1012B	Holder,Rail	308A	EBG32606502	Thermistor Assembly,PTC
131A	5074JJ1017A	Bucket,Ice	309A	6750C-0004S	Overload Protect
135C	3550JJ2030A	Cover,Grille Fan	310A	3550JA2059A	Cover,PTC
136C	3390JJ1058A	Tray,Drawer	312A	5040JA3031A	Damper,Compressor
140B	5027JJ2007A	Shelf Assembly,Refrigerator	314A	4620JA3009A	Stopper,Compressor
140D	MHL38615403	Shelf,Net	315A	3103JJ1001K	Base Assembly,Compressor
140E	MHL38615404	Shelf,Net	317A	5851JJ2002F	Drier Assembly
142D	5026JJ2001L	Shelf,Net	318A	4930JA3034A	Holder,Drier
142E	5026JJ2001M	Shelf,Net	319A	3390JJ0003A	Tray,Drip
143A	5027JJ1028E	Shelf Assembly,Refrigerator	319C	4974JJ1009A	Guide,Fan
143B	5027JJ1015A	Shelf Assembly,Refrigerator	319E	4810JJ0002A	Bracket,Motor
143E	5027JJ1008J	Shelf Assembly,Refrigerator	323B	5403JJ1005A	Condenser Assembly,Wire
143F	5027JJ1008C	Shelf Assembly,Refrigerator	327A	5006JA3034A	Cap,Drain Tube
145A	4930JJ2003A	Holder,Shelf	328A	4J03020A	Damper,Pipe
145B	4930JJ2004A	Holder,Shelf	328B	4J04328A	Damper,Pipe
146A	5047JJ1001A	Case,Lower	329A	5901JJ1005A	Fan Assembly
149A	5026JJ1058A	SHELF,FREEZER	329C	5901JJ1004B	Fan Assembly
151A	3390JJ1032A	Tray,Vegetable	332A	3531JJ1004B	Grille Assembly,Fan
151C	4940JJ2003A	Knob,Shutter	401A	6615JB2005C	Controller Assembly
154A	3550JL2001G	Cover,TV	404A	4680JK1002B	Motor, AC Freezing
155B	4981JJ2001B	Supporter Assembly,Cover TV	405A	4811JJ2002B	Bracket Assembly,Motor
158A	3550JJ1040A	Cover,Lamp	405B	4810JA3007A	Bracket,Motor
158E	MCK30060901	Cover,Lamp	405C	J756-00008B	Damper,Motor Support
167B	4890JL1002G	Shelf,Glass	406B	6600JB1010A	Switch,Push Button
170A	3391JJ2004G	Tray Assembly,Meat	409B	6912JK2002D	Lamp,Incandescent
200A	3581JJ8023F	Door Assembly,Freezer	409C	6912JK2002A	Lamp,Incandescent
201A	5433JJ0017P	Door Foam Assembly,Freezer	409D	3034JJ1002B	Reflector,Lamp
203A	4987JJ1004G	Gasket Assembly,Door	410A	6621JK2003B	Harness Assembly
205D	5004JJ1041A	Basket,Door	410G	0CZZJB2012J	Capacitor,Electric Appliance Film,Box
212A	3650JJ1031B	Handle,Refrigerator	411A	6411JK1006A	Power Cord Assembly
212F	4810JJ3015A	Bracket,Handle	418A	5300JB1100D	Heater,Sheath
212G	4140JL2001C	NAME PLATE	420A	4680JK1001B	Motor,AC
212J	4620JJ3007E	Stopper,Handle	501A	6871JB1215J	PCB Assembly,Main
230A	3581JJ8046C	Door Assembly,Refrigerator	501F	3551JJ1020A	Cover Assembly,PCB
231A	5433JJ0016S	Door Foam Assembly,Refrigerator	503C	6871JB2047A	PCB Assembly,Display
233A	4987JJ1004H	Gasket Assembly,Door	503D	3110JJ1005A	Case,Display
241A	3550JJ1024A	Cover,Tray	503E	3550JJ2031A	Cover,Display
241B	5004JJ1035A	Basket,Door	503F	ABQ33905307	Case Assembly,Display
241C	5004JJ1030A	Basket,Door	503G	3806JL1051A	Decor,Control
241D	5004JJ0002A	Basket,Door	610A	3550JJ2020A	Cover,Sensor
241E	5004JJ1028A	Basket,Door	619B	3550JJ2024A	Cover,Valve
243A	4620JJ3006C	Stopper,Door	623H	3550JJ2036A	Cover,Tube
244E	5006JJ3016C	Cap,Handle	700B	3651JJ2015B	Handle Assembly,Refrigerator
244E	5006JJ3016C	Cap,Handle	903A	3550JJ0005C	Cover,Lower
244P	3650JJ2012B	Handle,Freezer	903B	4930JJ2021A	Holder,Cover(Lower)
262E	4350JA3005B	Ring	903D	6500JK1003A	Sensor
281A	3550JJ2013C	Cover,Hinge	903E	6500JK1004A	Sensor
281B	4775JJ2003B	Hinge Assembly,Upper	B01	1STZJA3004F	Screw,Customized
281E	5006JJ3014C	Cap,Hinge	S01	1SZZJJ3010A	Screw,Customized
282B	4775JJ8002E	Hinge Assembly,Center	S02	1SZZJJ3010D	Screw,Customized
282C	1PZZJJ3002F	Pin,Common	S22	J471-00001J	Screw,Customized
282E	5006JJ2001F	Cap,Hinge	S24	1SZZJA3011B	Screw,Customized
282F	3806JL2006D	Decor,Duct	S27	4J01424C	Screw,Customized
282H	5006JJ3004E	Cap,Hinge	S38	4J00415D	Screw,Customized



*'You Can Count on me . . .
to Work Safely.'*