



Internal Use Only

Website: <http://biz.lgservice.com>

MICROWAVE OVEN SERVICE MANUAL

**MODEL: LMVM2085SB
LMVM2085ST
LMVM2085SW**

CAUTION

BEFORE SERVICING THE UNIT, READ THE
SAFETY PRECAUTIONS IN THIS MANUAL.

P/NO : MFL06272505

March, 2008
Printed in Korea

CAUTION

WARNING TO SERVICE TECHNICIANS

PRECAUTIONS TO BE OBSERVED BEFORE AND DURING SERVICING TO AVOID POSSIBLE EXPOSURE TO EXCESSIVE MICROWAVE ENERGY

- a. Do not operate or allow the oven to be operated with the door open.**
- b. Make the following safety checks on all ovens to be serviced before activating the magnetron or other microwave source, and make repairs as necessary; (1) Interlock operation, (2) proper door closing, (3) seal and sealing surfaces (arcing, wear, and other damage), (4) damage to or loosening of hinges and latches, (5) evidence of dropping or abuse.**
- c. Before turning on microwave power for any service test or inspection within the microwave generating compartments, check the magnetron, wave guide or transmission line, and cavity for proper alignment, integrity, and connections.**
- d. Any defective or misadjusted components in the interlock, monitor, door seal, and microwave generation and transmission systems shall be repaired, replaced, or adjusted by procedures described in this manual before the oven is released to the owner.**
- e. A Microwave leakage check to verify compliance with the Federal performance standard should be performed on each oven prior to release to the owner.**
 - Proper operation of the microwave ovens requires that the magnetron be assembled to the wave guide and cavity. Never operate the magnetron unless it is properly installed.
 - Be sure that the magnetron gasket is properly installed around the dome of the tube whenever installing the magnetron.
 - Routine service safety procedures should be exercised at all times.
 - Untrained personnel should not attempt service without a thorough review of the test procedures and safety information contained in this manual.

FOREWORD

Read this Manual carefully. Failure to adhere to or observe the information in this Manual may result in exposing yourself to the Microwave Energy normally contained within the oven cavity.

CONTENTS

{Page}

Safety Precautions	2
1. Specification	4
2. Cautions	5
3. Installation	6
4. Operation	7
4-1. Control Panel Features	7
4-2. Explanation of Control Panel.....	8
5. Wiring Diagram / Key Matrix	9
5-1. Wiring Diagram	9
5-2. Key Matrix	10
6. Troubleshooting	11
6-1. General Information for Service	11
6-2. Safety Caution.....	12
6-3. Basic Check Summary.....	13
6-4. Troubleshooting	14
7. Microwave Leakage Test	25
8. Power Output Measurement	27
9. Interlock System	28
9-1. Interlock Mechanism	28
9-2. Interlock Continuity Test.....	30
10. Component Testing Information	31
11. Disassembly Instructions	35
12. Exploded View	43

1. SPECIFICATIONS

Rated Power Consumption	1700W maximum (Microwave oven+Cook top lamps+Ventilation fan)
Microwave Output	1100W (IEC60705)
Frequency	2450 MHz \pm 50 MHz
Power Supply	120 VAC, 60 Hz
Rated Current	14.5 Amp. (Microwave oven+Cook top lamps+Ventilation fan)
Magnetron Cooling	Forced Air Cooling
Rectification	Rectification Voltage Double Half-Wave
Door Sealing	Choke System
Safety Devices	Magnetron Thermostat: Open at 145 °C \pm 5 °C Close at 60 °C \pm 5 °C Oven Thermostat: Open at 145 °C \pm 5 °C Close at 0 °C \pm 5 °C Fuse (20A) Primary Interlock Switch Secondary Interlock Switch Interlock Monitor Switch
Heater	120 V, 500W (Sheath)
Magnetron	2M282J (Toshiba)
Cook top Lamp	12 VAC, 20 W (Halogen)
Cavity Lamp	125 V, 30 W or 40 W
Timer	Digital, up to 99 min.(in each cooking stage)
Tray	Tempered Safety Glass
Overall Dimensions	29 ^{15/16} " (W) x 16 ^{7/16} " (H) x 15 ^{5/8} " (D)
Oven Cavity Size	23 ^{1/2} " (W) x 10"(H) x 14 ^{1/2} " (D)
Effective Capacity of Oven Cavity	2.0 Cu.ft.
Accessories	Owner 's Manual &Cooking Guide, Installation Manual, Exhaust Adapter, Exhaust Damper, Mounting Kit and Filter, Rotating Ring Assembly, Glass Tray, Metal Rack, Guide Tray, Defrosting (Melting/Softening) Racking.

SWITCH CHART

SWITCH MODE	PRIMARY INTERLOCK SWITCH	SECONDARY INTERLOCK SWITCH	INTERLOCK MONITOR SWITCH
CONDITIONS	COM NO	COM NO	COM NC
DOOR OPEN	OPEN	OPEN	CLOSE
DOOR CLOSED	CLOSE	CLOSE	OPEN

NOTE: Use the above switch chart with circuit diagram on page 5-1.

2. CAUTIONS

Unlike other appliances, the microwave oven is high-voltage and high-current equipment. Though it is free from danger in ordinary use, extreme care should be taken during repair.

- DO NOT operate on a 2-wire extension cord during repair and use.
- NEVER TOUCH any oven components or wiring during operation.
- BEFORE TOUCHING any parts of the oven, always remove the power plug from the outlet.
- Remove your watches whenever working close to or replacing the magnetron.
- DO NOT touch any parts of the control panel circuit. A resulting static electric discharge may damage this P.C.B.
- NEVER operate the oven with no load.
- NEVER injure the door seal and front plate of the oven cavity.
- NEVER put iron tools on the magnetron.
- NEVER put anything into the latch hole and the interlock switches area.

MICROWAVE RADIATION

Personnel should not be exposed to the microwave energy which may radiate from the magnetron or other microwave generating device if it is improperly used or connection. All input and output microwave connections, waveguide, flange, and gasket must be secure never operate the device without a microwave energy absorbing load attached. Never look into an open waveguide or antenna while the device is energized.

- Proper operation of the microwave oven requires that the magnetron be assembled to the waveguide and cavity. Never operate the magnetron unless it is properly installed.
- **Be sure that the magnetron gasket is properly installed around the dome of the tube whenever installing the magnetron.**

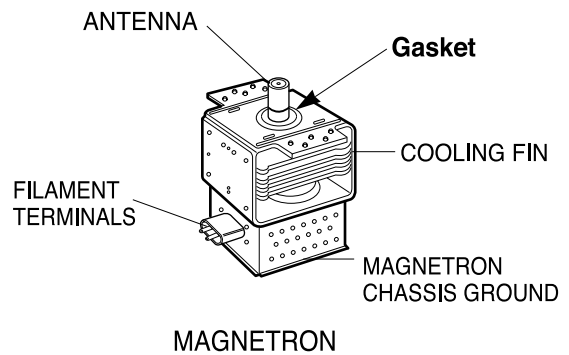

THE OVEN IS TO BE SERVICED ONLY BY PROPERLY QUALIFIED SERVICE PERSONNEL.

3. INSTALLATION

BEFORE YOU BEGIN, READ THE FOLLOWING INSTRUCTIONS COMPLETELY AND CAREFULLY.

PRECAUTIONS ON INSTALLATION

- A. Plug the power supply cord into a 120V AC, 60Hz, single-phase power source with a capacity of at least 20 amperes.
- B. Avoid placing the unit in a location where there is direct heat or splashing water.
- C. Install the unit on the mounting plate firmly.
- D. Place the unit as far away as possible from TV, radio, etc. to prevent interference.

GROUNDING INSTRUCTIONS

For personal safety, this appliance must be fully grounded at all times.

In the event of an electrical short circuit, grounding reduces the risk of electrical shock.

The plug must be plugged into an outlet that is properly installed and grounded.

CAUTION

This unit is equipped with a 3-prong plug for your safety. If the wall outlet is a grounded 3-hole type, the unit will be grounded automatically.

Plug with Ground Prong

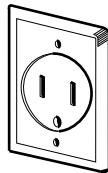
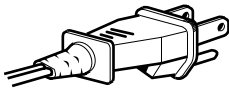

Properly Polarized and Grounded Outlet

WARNING

Improper use of the grounding plug can result in a risk of electric shock.

Do not, under any circumstances, cut or remove the third ground prong from the power cord plug.

4. OPERATION

4-1. Control Panel

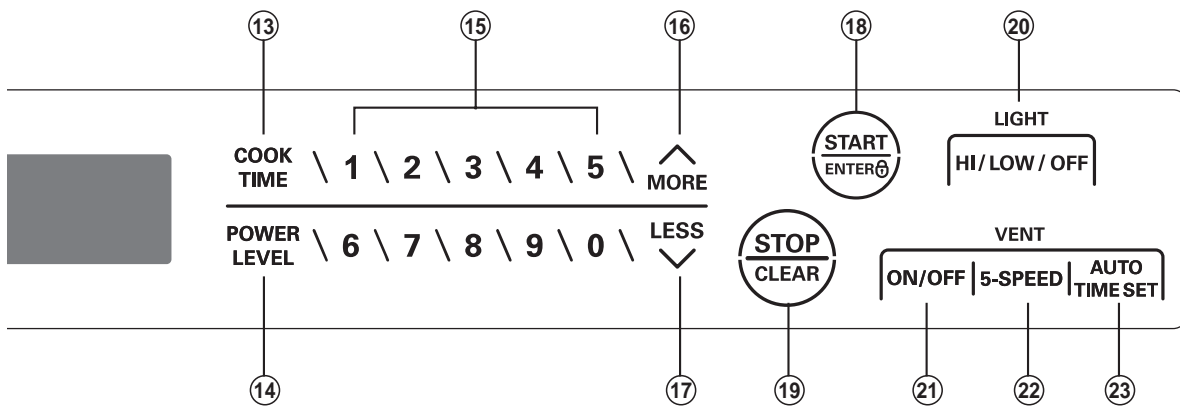
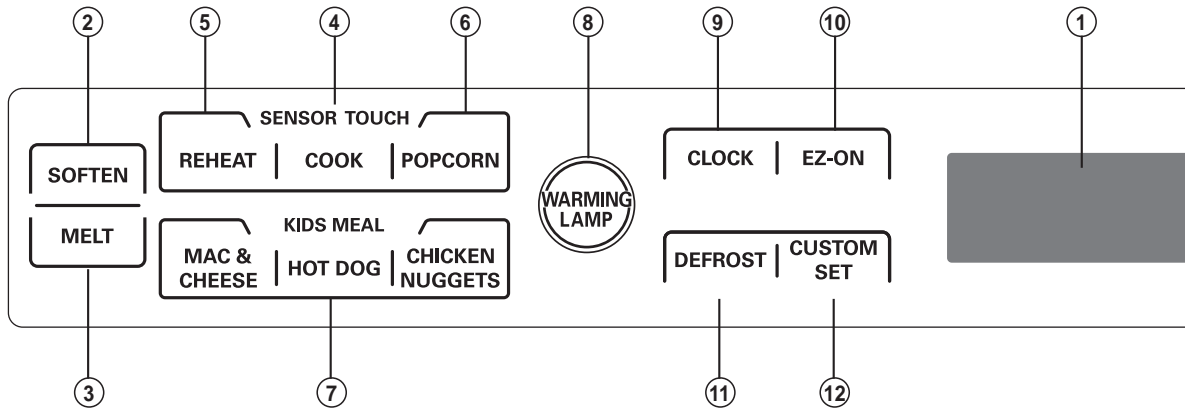

4-2. Explanation of Control Panel

1. **DISPLAY** The Display includes a clock and indicators to tell you time of day, cooking time setting, and cooking functions selected.
2. **SOFTEN** Touch this pad to soften Butter, Ice Cream, Cream Cheese, and Frozen Juice.
3. **MELT** Touch this pad to melt Butter / Magarine, Chocolate, Cheese, and Marshmallows.
4. **COOK** Touch this pad to cook Baked Potato, Vegetable Casserole, Rice, and Frozen Entrée. The oven's sensor will tell the oven how long to cook depending on the amount of humidity coming from the food.
5. **REHEAT** Touch this pad to reheat Pizza Slice, Dinner Plate, Soup/Sauce, and Casserole. The oven's sensor will tell the oven how long to cook depending on the amount of humidity coming from the food.
6. **POPCORN** Touch this pad when popping popcorn in your microwave oven. The oven's sensor will tell the oven how long to cook depending on the amount of humidity it detects from the popcorn.
7. **KIDS MEAL** Select type of dish to reheat HOT DOG, MAC & CHEESE or CHICKEN NUGGETS.
8. **WARMING LAMP** Touch this pad to keep hot cooked foods warm in your oven.
9. **CLOCK** Touch this pad to enter the time of day.
10. **EZ-ON** Touch this pad to set and start quickly at 100% power level.
11. **DEFROST** Touch this key to defrost food by entering weight, cook time or Quickly.
Touch this key 2 times to Quick Defrost Cook.
Touch this key 3 times to Time Defrost Cook.
12. **CUSTOM SET** Touch this pad to change the oven's default setting for sound, clock, display speed, and defrost weight.
13. **COOK TIME** Touch this pad to set a cooking time.
14. **POWER LEVEL** Touch this pad to select a cooking power level.
15. **NUMBER** Touch number pads to enter cooking time, power level, quantities, or weights.
16. **MORE** Touch this pad to add ten seconds of cooking time each time you press it.
17. **LESS** Touch this pad to subtract ten seconds of cooking time each time you press it.
18. **START/ENTER** Touch this pad to start a function. If you open the door after oven begins to cook, touch START/ENTER again.
19. **STOP/CLEAR** Touch this pad to stop the oven or to clear all entries.
20. **LIGHT HI/LOW/OFF** Touch this pad to turn the light on high, low, or off.
21. **VENT ON/OFF** Touch this pad to turn the fan on/off.
22. **VENT 5-SPEED** Touch this pad to choose one of 5 fan speeds.
23. **VENT AUTO TIME SET** Touch this pad when setting ventilation time. (1, 3, 5, 10, and 30 minutes.)

5. WIRING DIAGRAM / KEY MATRIX

5-1. Wiring Diagram

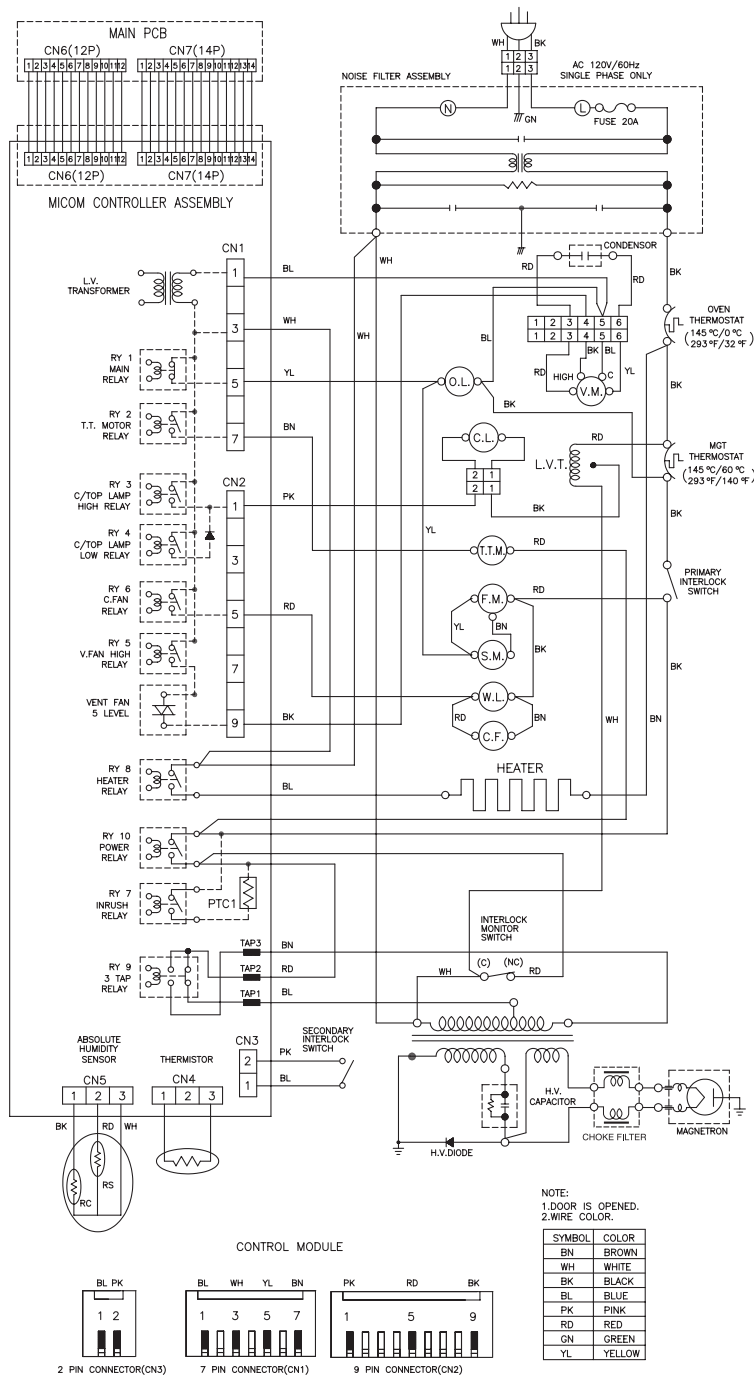

5-2. Key Matrix

KEY MATRIX

	1	2	3	4	5	6	7
8	1	2	3	4	5	6	7
9	N.C	COOK TIME	N.C	N.C	N.C	N.C	N.C
10	VENT ON/OFF	VENT 5-SPEED	LIGHT HI/LOW/OFF	MAC & CHEESE	AUTO TIME SET	SOFTEN	MELT
11	SENSOR POPCORN	SENSOR COOK	SENSOR REHEAT	DEFROST	EZ-ON	HOT DOG	CHICKEN NUGGETS
12	CUSTOM SET	WARMING LAMP	N.C	N.C	CLOCK	MORE	LESS
13	POWER LEVEL	N.C	STOP/CLEAR	START/ENTER	8	9	0

6. TROUBLESHOOTING

6-1. General Information for Service

GENERAL PRECAUTIONS IN USE

- A. Never operate the unit when it is empty.
Operating the oven with no load may shorten the life of the magnetron. Whenever cooking dry foods (dried fish, bread, etc.) or a small amount of food, be sure to put a glass of water into the cooking compartment. The glass turntable may become hot after operating, be careful when touching it.
- B. Aluminum foil should be avoided because it will disrupt cooking and may cause arcing. However, small pieces may be used to cover some parts of food to slow the cooking. Any aluminum foil used should never be closer than 2.5 cm to any side wall of the oven.

TRIAL OPERATION

After installation, the following sequences and results should be checked carefully.

- A. Put a container filled with water (about 1 liter) into the oven, and close the door tightly.
- B. Set cooking time for 10 minutes.
- C. Press DIAL to start.
Make sure the cavity light comes on. The unit will begin cooking and the display window will show the time counting down by seconds.
- D. After about 5 minutes, make sure the primary interlock switch, the secondary interlock switch and the interlock monitor switch operate properly by opening and closing the door several times.
Press the DIAL key each time the door is closed.
- E. Continue operating the unit. For long beep sound signal is heard when the time is up. The unit will shut off automatically.
- F. Confirm the water is hot.
- G. Finally, measure the output power according to POWER OUTPUT MEASUREMENT on page 8.

FEATURES AND SPECIFICATIONS FEATURES

- A. The safety systems incorporated in this model are:
 - (1) Primary interlock switch
 - (2) Secondary interlock switch
 - (3) Interlock monitor switch
 - (4) Choke system
 - (5) Oven cavity thermostat
(**Note:** This thermostat located on the oven cavity will open and stop the unit from operation only if a high temperature is reached, such as, a fire created by overcooking food.)
- B. Any one of 10 power output levels ranging 0 W to 1,100 W can be selected by the touch control and electronic computer system.

6-2. Safety Caution

A. SINCE NEARLY 4,000 VOLTS EXISTS IN SOME CIRCUITS OF THIS UNIT REPAIRS SHOULD BE CARRIED OUT WITH GREAT CARE.

The filament leads of magnetron carry High Voltage with respect to ground. Extreme caution must be exercised. Never plug the unit into a power source to determine which component is defective in high voltage section.

B. TO AVOID POSSIBLE EXPOSURE TO MICROWAVE ENERGY LEAKAGE, THE FOLLOWING PRECAUTIONS MUST BE TAKEN BEFORE SERVICING.

- (1) Before the power is applied:
 - (a) Make sure the primary interlock switch, the secondary interlock switch and the interlock monitor switch operate properly by opening and closing the door several by opening and closing the door several times.
 - (b) Make sure the perforated screen and the dielectric choke of the door are correctly and firmly mounted.
- (2) After power is applied:
 - (a) Make sure the interlock switch mechanism is operating properly by opening and closing the door.
 - (b) Check microwave energy leakage must be below the limit of 5 mW/cm^2 .
(All service adjustments should be made for minimum microwave energy leakage readings).
- (3) Do not operate the unit until it is completely repaired, if any of the following conditions exist. The unit must not be operated.
 - (a) The door does not close firmly.
 - (b) The hinge is broken.
 - (c) The door seal is damaged.
 - (d) The door is bent or warped, or there is any other visible damage on the unit that may cause microwave energy leakage.
NOTE: Always keep the seal clean.
 - (e) Make sure that there are no defective parts in the interlock mechanism.
 - (f) Make sure that there are no defective parts in the microwave generating and transmission assembly (especially waveguide).
- (4) The following items should be checked after the unit is repaired:
 - (a) The interlock monitor switch is connected correctly and firmly.
 - (b) The magnetron gasket is properly positioned and mounted.
 - (c) The waveguide and the oven cavity are intact.
(no microwave energy leakage)
 - (d) The door can be properly closed and the safety switches work properly.
 - (e) The unit must stop when the door is opened or the time is up.

The unit must not be operated with any of the above components removed or bypassed.

6-3. Basic Check Summary

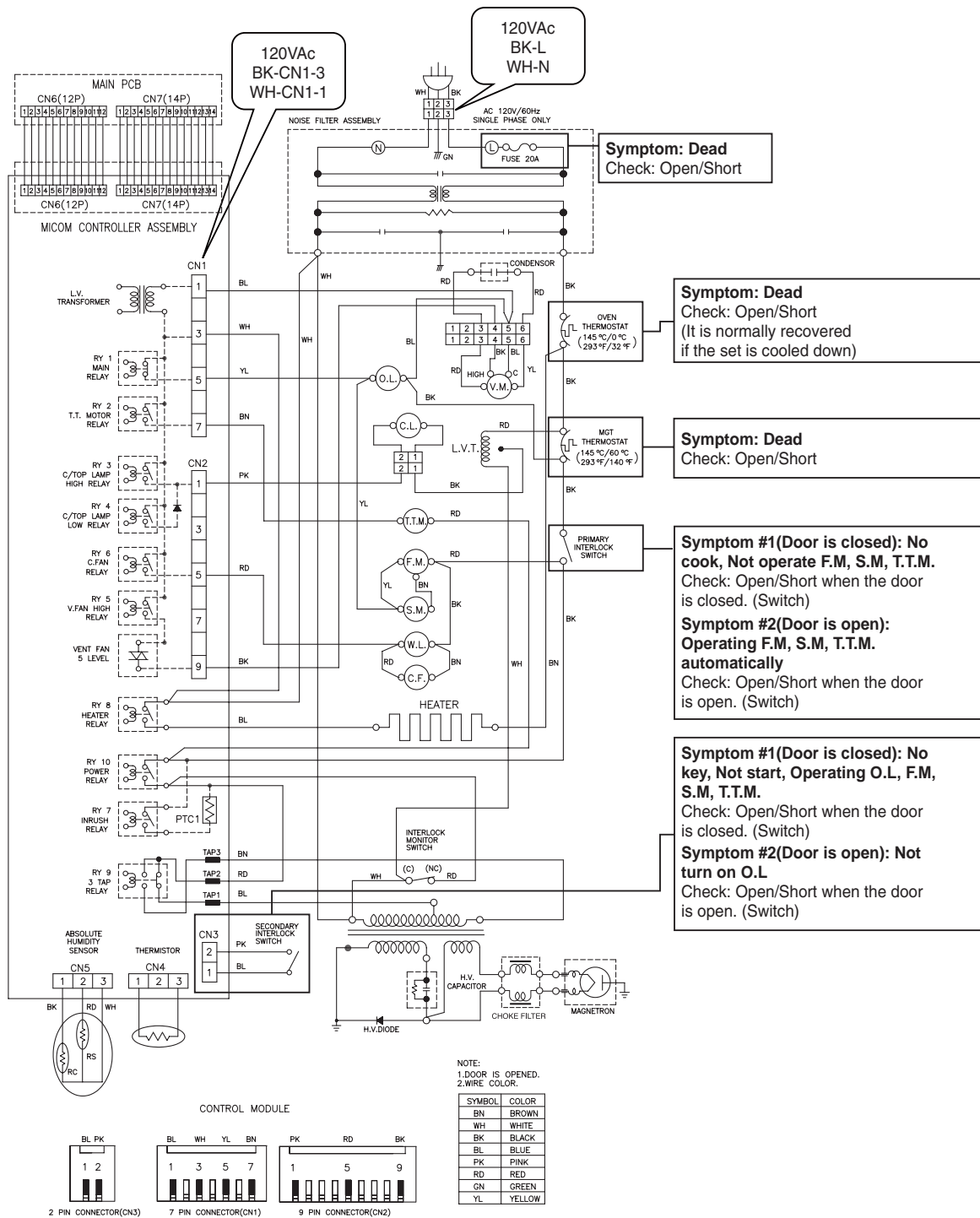

6-4. Troubleshooting

No Display or Dead

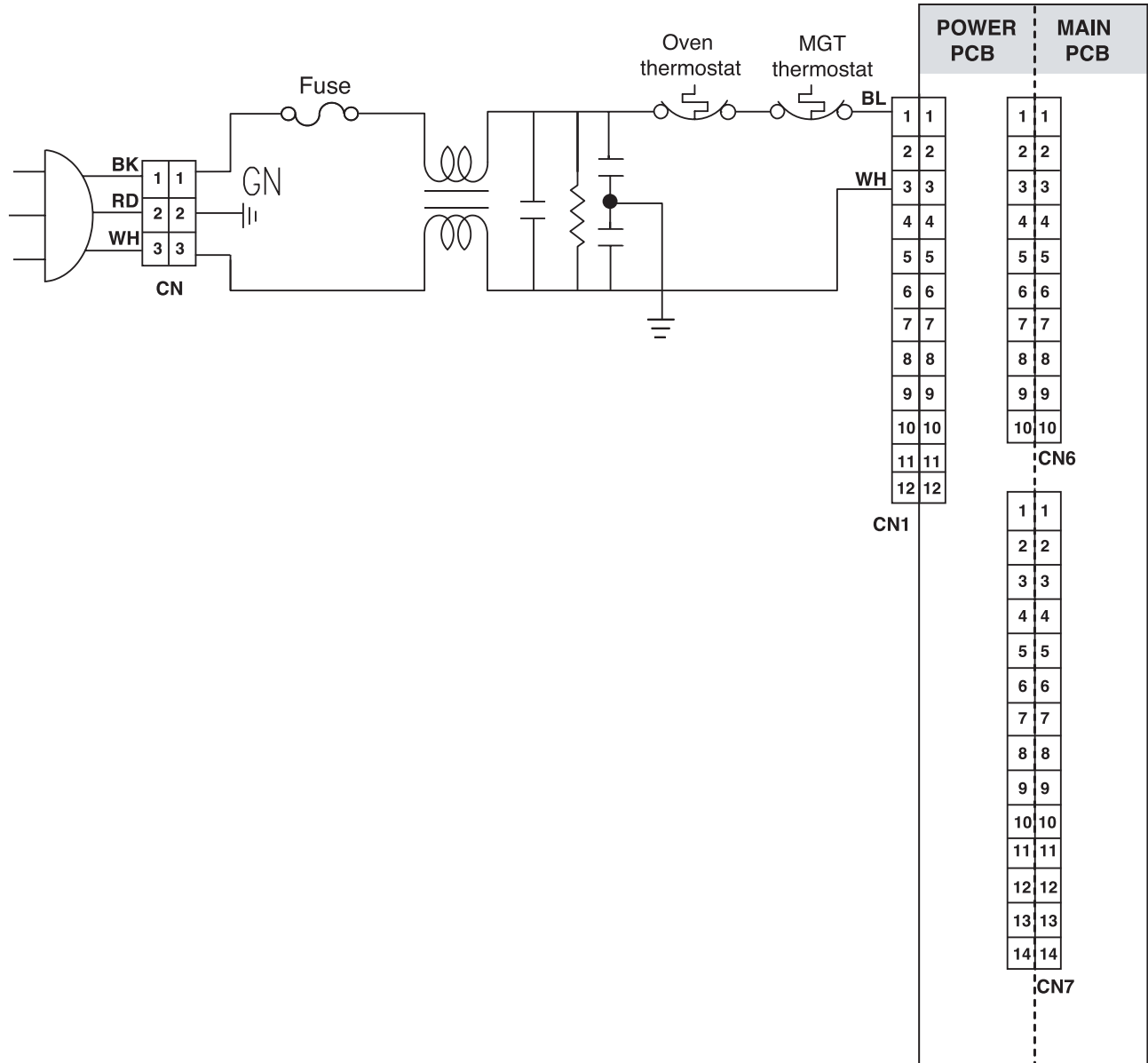

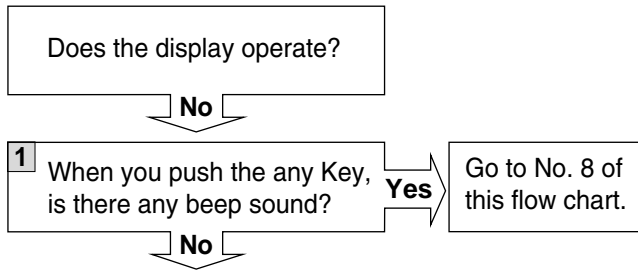

Power Off

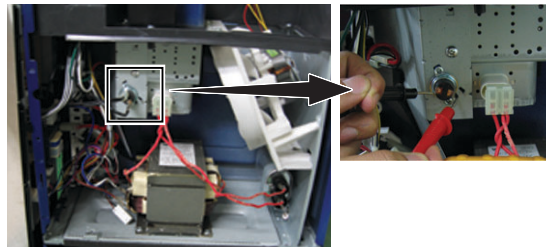
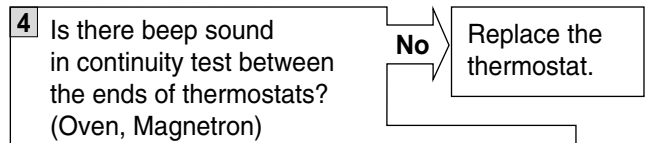
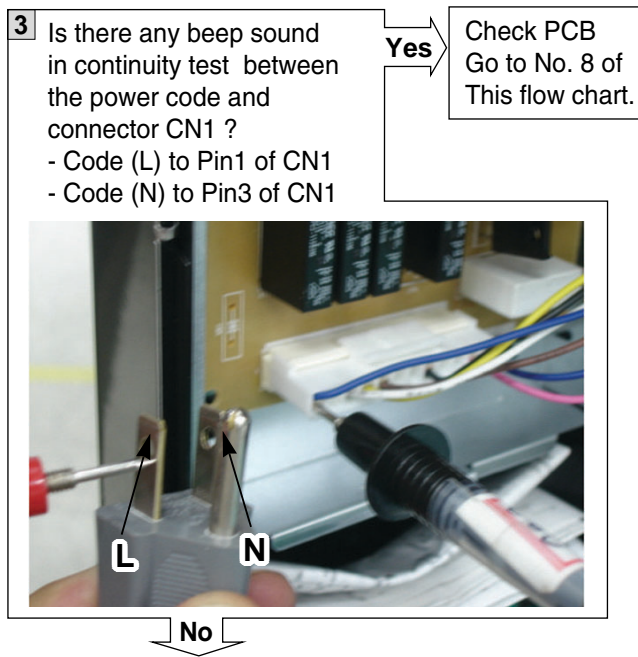
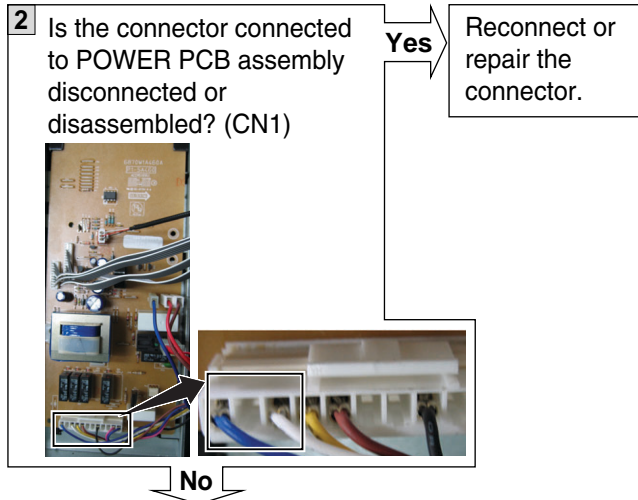

Oven thermostat

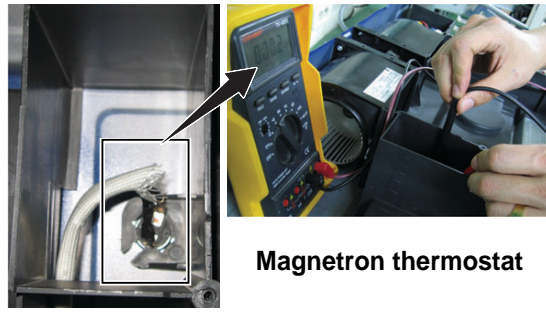

Magnetron thermostat

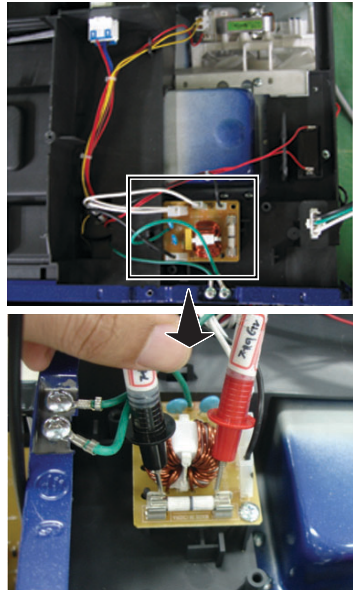
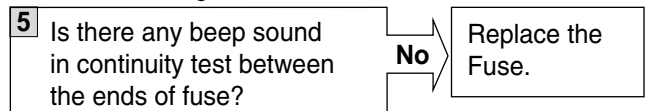
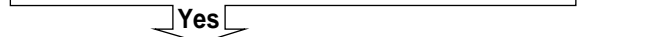

6 Is there any beep sound in continuity test between the ends of the noise filter?

No → Replace the Noise filter.

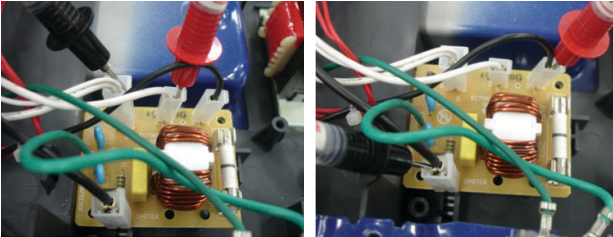

Neutral terminal of Noise filter **Live terminal of Noise filter**

Yes ↓

7 Is the connector connected to POWER PCB assembly disconnected or disassembled? (CN6)

Yes → Reconnect or repair the connector.

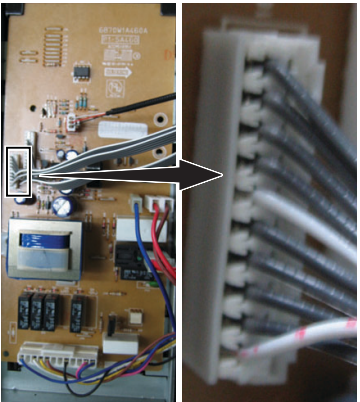

No ↓

Power ON

8 Is the voltage of POWER PCB out of range?

Normal condition

- Pin 2 to Pin 3 of CN6 > 20 V
- Pin 2 to Pin5 of CN 6 > 10 V

No → Replace the Power PCB (6871W1A460)

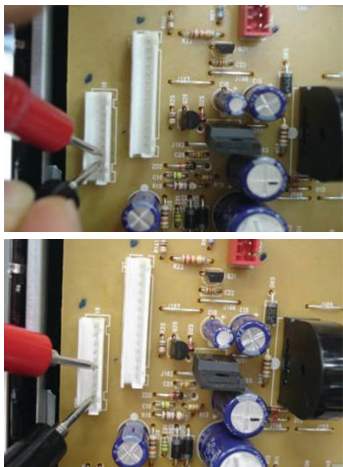

Yes ↓

Replace the MAIN PCB (6871W1A459)

Keypad Failure

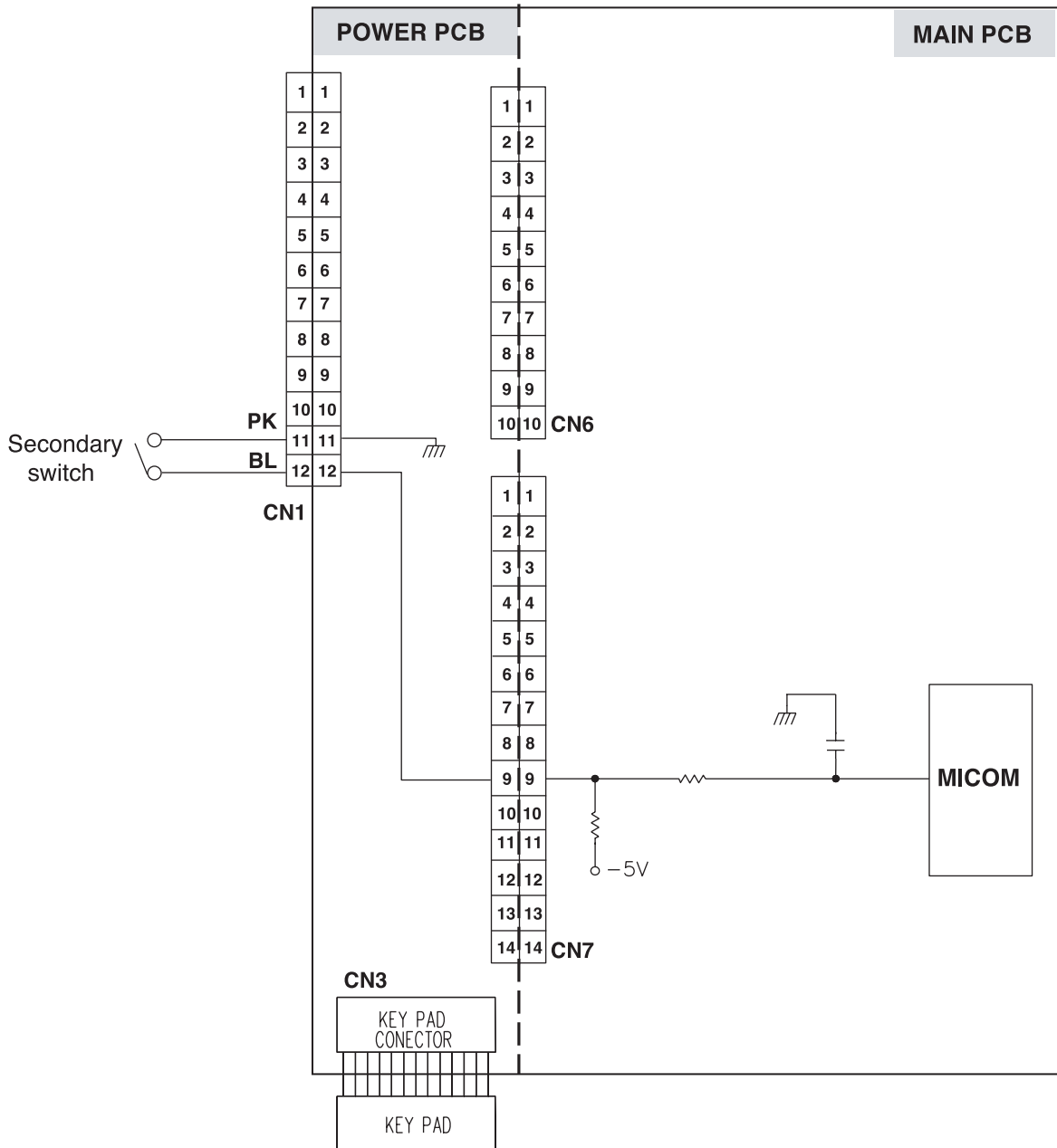

- Start key or EZ-ON key works if the door is closed.

Does the keys operate?

No

Power ON

1 Do not only START key and EZ-ON key operate?
(Door should be closed.)

No

Check PWB
Go to No. 4 of
this flow chart.

Yes

2 Is there beep sound
in continuity test between
the ends of latch board?
- secondary switch
(Door should be closed.)

No

Adjust latch
board
(Refer to 9-1,
9-2)

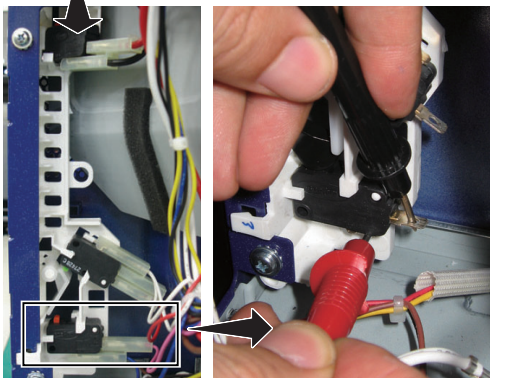
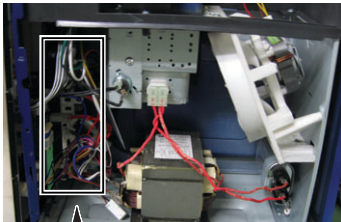

Yes

3 When the door is opened,
Is the voltage of door
sensing part over 4 V?
(Pin11 of CN1 to
Pin12 of CN1)

No

Replace the
POWER PCB
(6871W1A460)

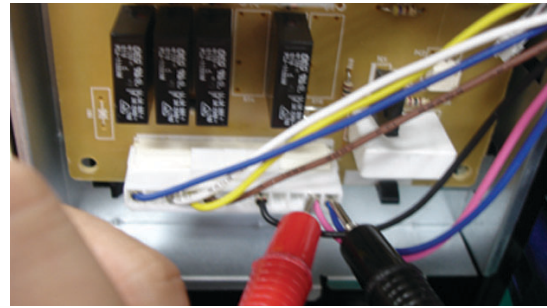

Yes

4 Is the connector connected
to MAIN PCB assembly
disconnected or
disassembled? (CN3)

Yes

Reconnect or
repair
the connector.

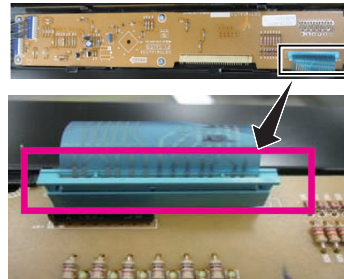

No

5 Replace the MAIN PCB
6871W1A495A.
Replace the keypad if
changing the MAIN PCB
doesn't resolve the issue.

No Heat / No Cook

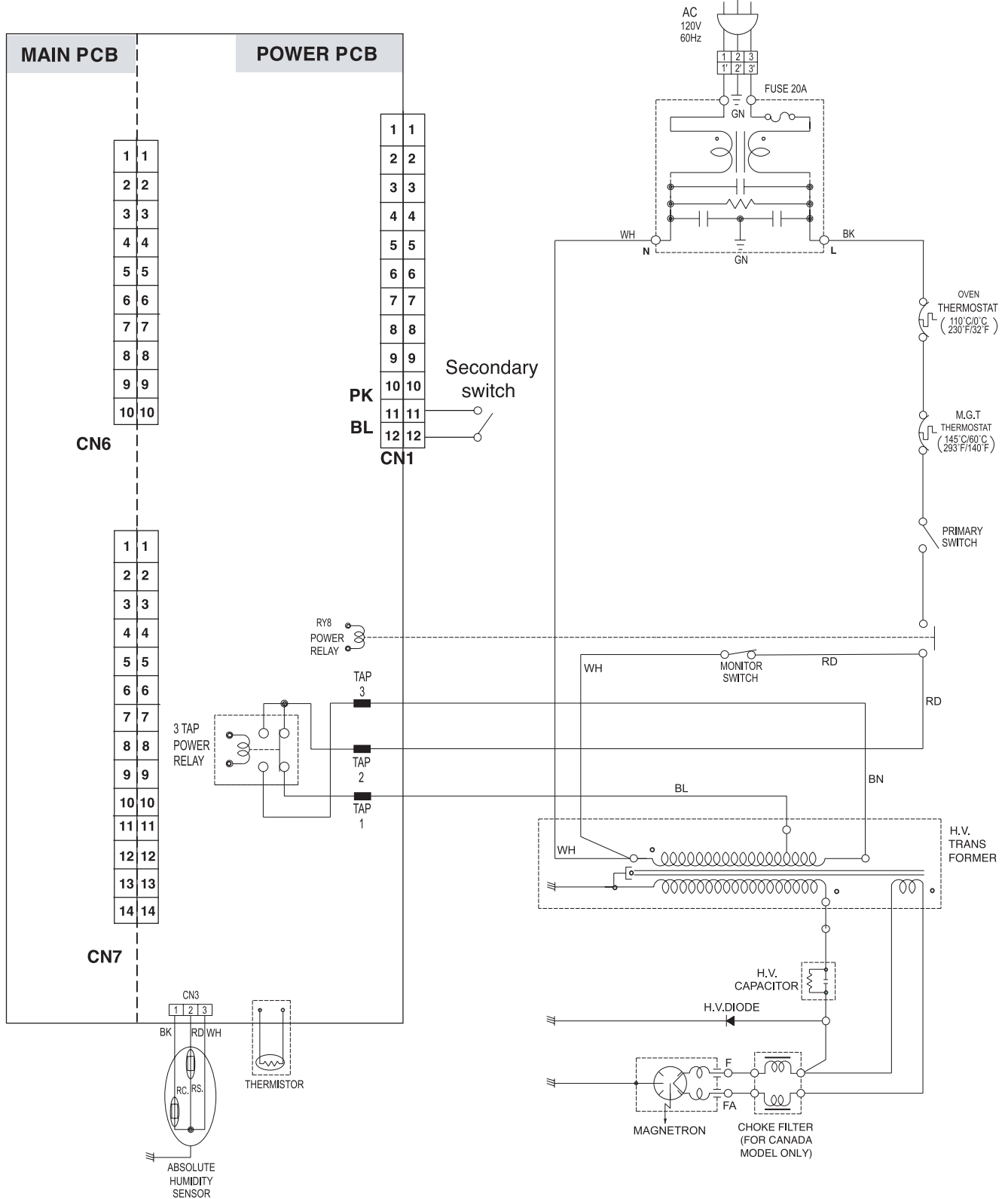

After power on, does the product operate?

No

1 Repeat Door Open and close more than three times. Does product operate?

Yes

Alternate with explanation (Refer to the Note)

No

2 Is there any beep sound in continuity test between TAB1 and TAB2?

Yes

Go to No. 4 of this flow chart.

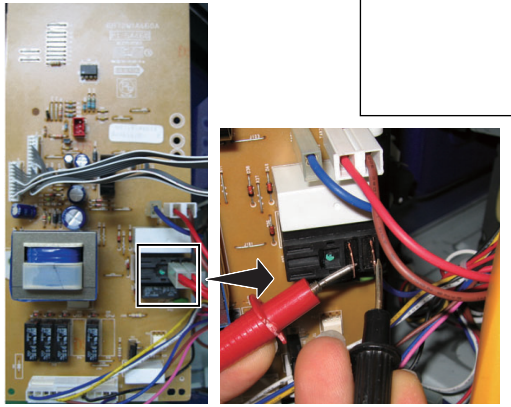

Yes

3 Is the connector connected to Power PCB and MAIN PCB assembly disconnected or disassembled? (CN6, CN7)

Yes

Reconnect or repair the connector.

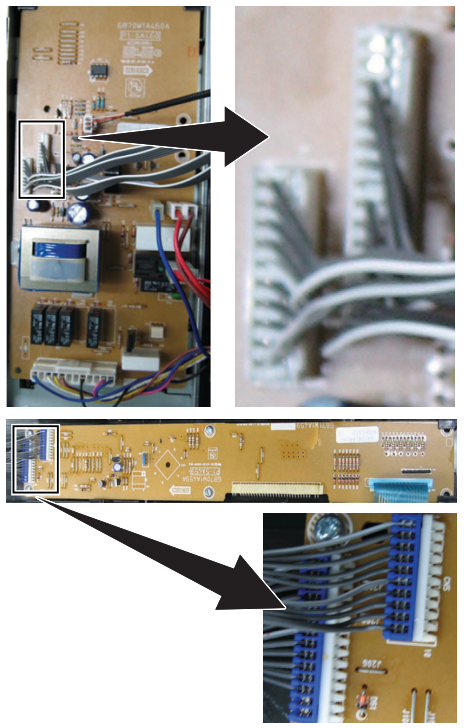

No

4 While the product is operating under EZ-ON start, is the voltage of both ends of the D36 over 8 V?

Yes

Replace the POWER PCB 6871W1A460

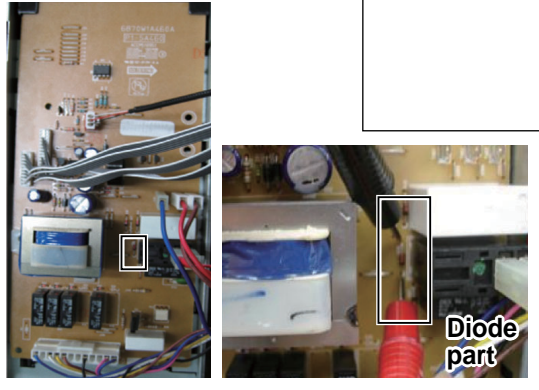

No

Replace the MAIN PCB 6871W1A459A

Power Off

5 Is there any beep sound in continuity test between the ends of latch board?
- primary switch
(Door should be closed.)

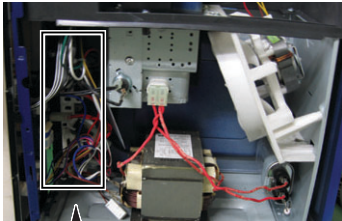

No

Adjust latch board
(Refer to 9-1, 9-2)

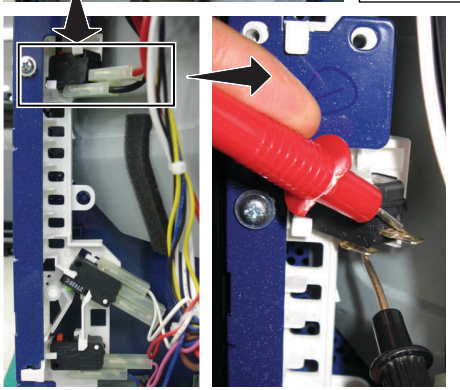

Yes

6 Is the connector connected to High Voltage Transformer assembly disconnected or disassembled?

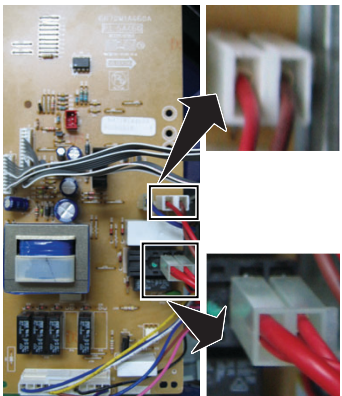

Yes

Reconnect or repair the connector.

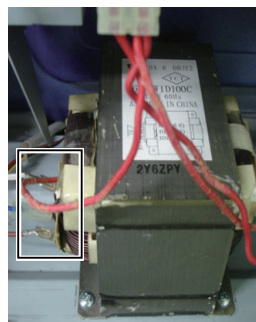

No

7 Is the resistance of high voltage Transformer out of range? (Refer to 10)

Yes

Replace the High Voltage Transformer.

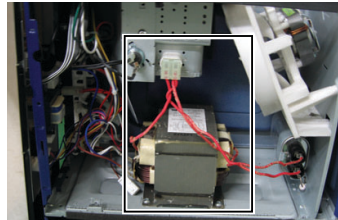

Test Point

1. Primary winding (High, Low): 0.2 ~ 0.5 Ohm

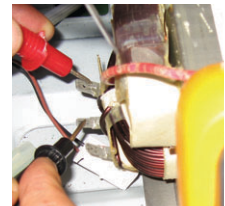
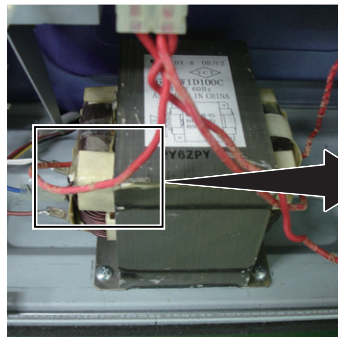

High

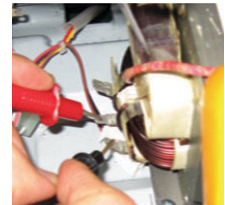

Low

2. Secondary winding: 50 ~ 120 Ohm

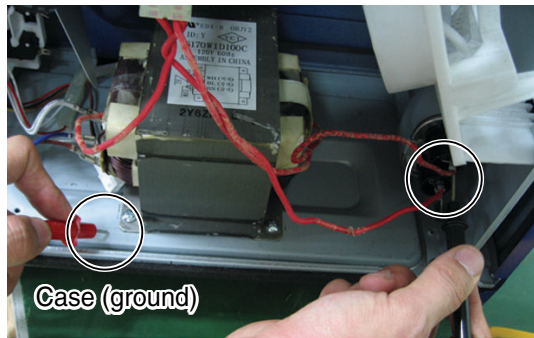

Case (ground)

3. Filament winding: 0 Ohm

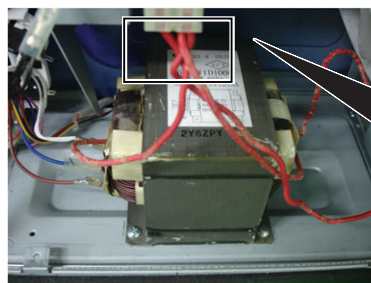

No

8 Is the connector connected to High Voltage capacitor assembly disconnected or disassembled?

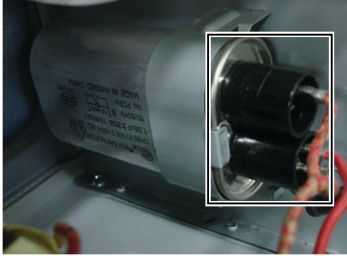

No

Yes

Reconnect or repair the connector.

11 Is the resistance of the high voltage diode out of range? (Refer to 10)

Test Point

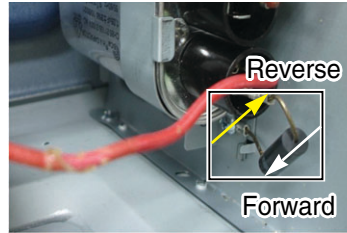

Yes

No

Replace the high voltage Diode.

9 Is the resistance of the high voltage capacitor out of range? (Refer to 10)

Test Point

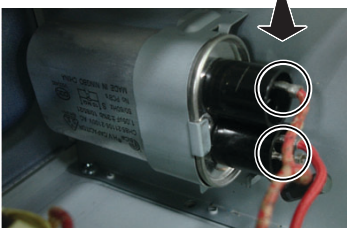
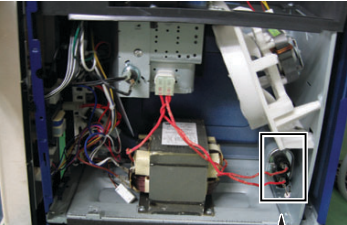

No

Yes

Replace the high voltage capacitor.

12 Is the connector connected to the magnetron assembly disconnected or disassembled?

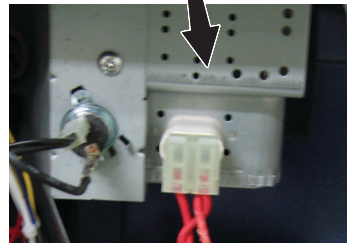
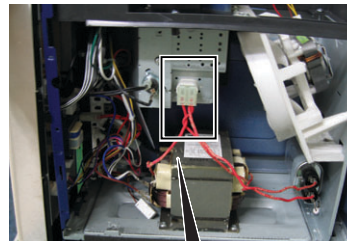

Yes

Reconnect or repair the connector.

10 Is the connector connected to the high voltage diode assembly disconnected or disassembled?

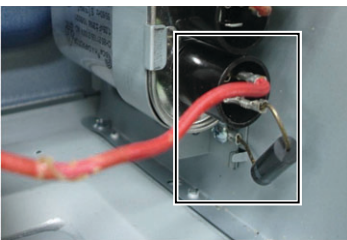

No

Yes

Reconnect or repair the connector.

[Note]

If the door of microwave is not completely closed caused of environmental condition, the microwave will not operate for safety.

Turntable Motor Does Not Work

Power ON

Does the turntable motor operate?

No

1 Does the fan motor turn on when EZ-ON button is pressed?

Yes

Replace the turntable motor.

No

2 When door is closed, does the oven lamp turn on?

Yes

Adjust the Primary latch board
(Refer to 9-1, 9-2)

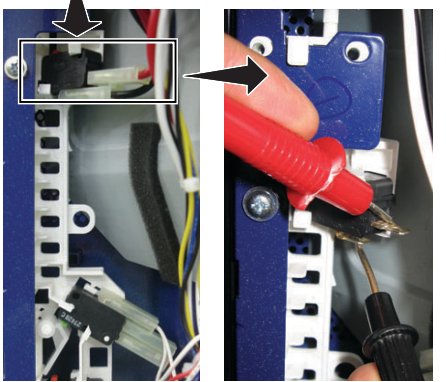
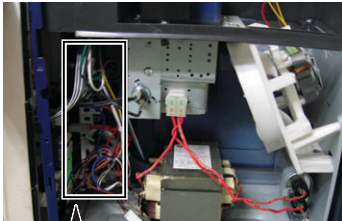

No

3 Push the EZ-ON (Operate) button. Is the voltage of both ends of the D30 over 8 V?

Yes

Replace the POWER PCB.

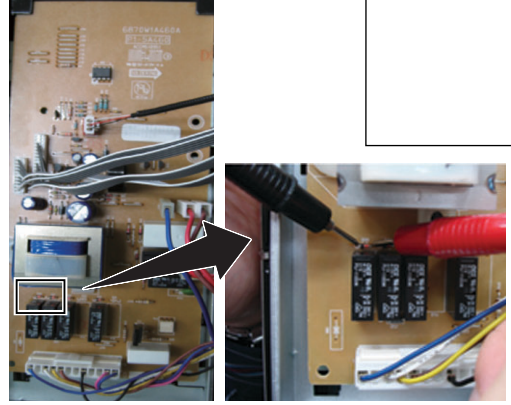

No

4 Is the connector connected to Power PCB and MAIN PCB assembly disconnected or disassembled? (CN6, CN7)

Yes

Reconnect or repair the connector.

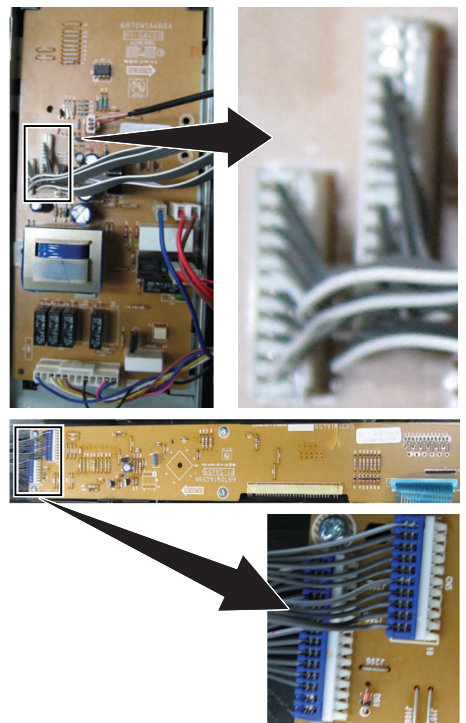

No

Replace the MAIN PCB.

Turn on automatically

Is the product turn on automatically without pushing the start key?

Yes

1 Repeat Door Open and close more than three times. Dose the product operate?

No

Yes

Alternate with explanation (Refer to the Note)

Power Off

2 Is there any beep sound in continuity test between the ends of latch board? - secondary switch (Door should be closed.)

No

Adjust latch board (Refer to 9-1, 9-2)

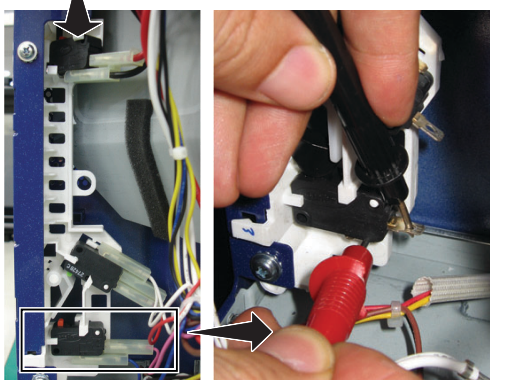
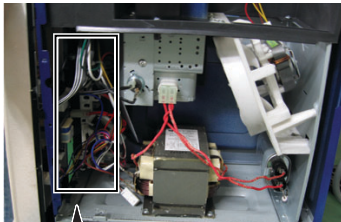

Yes

Power ON

3 When the door is closed, does the oven lamp turn on?

Yes

No

Replace the turntable Motor.

4 When the door is opened, is the voltage over 4.0V? (Pin 11 of CN1 to Pin 12 of CN1)

No

Replace the POWER PCB (6871W1A460)

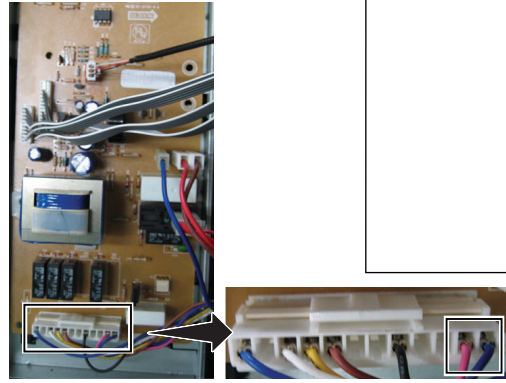

Yes

5 Is the voltage of both ends of the D30 over 8 V?

Yes

Replace the POWER PCB.

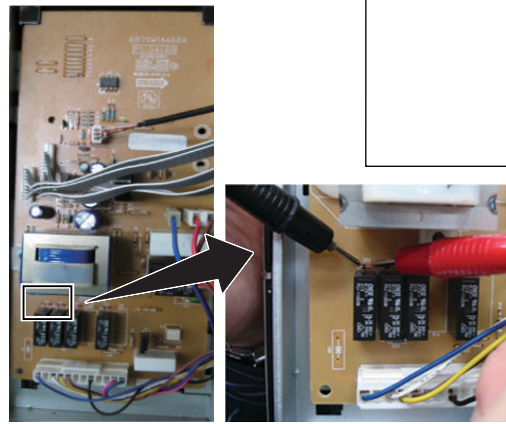

No

Is the connector connected to Power PCB and MAIN PCB assembly disconnected or disassembled? (CN6, CN7)

Yes

Reconnect or repair the connector.

No

Replace the POWER PCB 6871W1A460

[Note]

If something is caught in the door or in the sealing area, the microwave oven cannot operate safely. The latch switches and monitor switch will prevent operation.

7. MICROWAVE LEAKAGE TEST

CAUTIONS

- **Be sure to check microwave leakage prior to servicing the oven if the oven is operative prior to servicing.**
- **The service personnel should inform the manufacturer, importer, or assembler of any certified oven unit found to have a microwave emission level in excess of 5 mW/cm² and should repair any unit found to have excessive emission levels at no cost to the owner and should ascertain the cause of the excessive leakage. The service personnel should instruct the owner not to use the unit until the oven has been brought into compliance.**
- If the oven operates with the door open, the service personnel should;
 - Tell the user not to operate the oven
 - Contact the manufacturer and CDRH (Center for Devices and Radiological Health) immediately.

NOTE: Address on CDRH

Office of Compliance (HFZ-312)
Center for Devices and Radiological Health
1390 Piccard Drive Rockville, Maryland 20850

- The service personnel should check all surface and vent openings for microwave emission testing.
- Check for microwave energy leakage after every servicing. The power density of the microwave radiation leakage emitted by the microwave oven should not exceed 1mW/cm.sq. And always start measuring of an unknown field to assure safety for operating personnel from radiation leakage.

NOTE: The standard is 5mW/cm.sq. while in the customer's home. 1mW/cm.sq.stated here is manufacturer's own voluntary standard for units in customer's home.

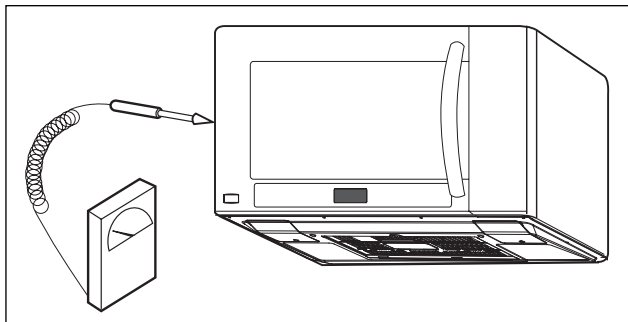

EQUIPMENT-

- TESTER (VOLTS-DC, AC, Ohmmeter)
- Microwave survey meter
 - Holaday HI-1500
 - HI-1501
 - Narda 8100
 - 8200
- 600 cc non conductive material beaker (glass or plastic), inside diameter: approx. 8.5 cm (3 1/2 in.)
- Glass thermometer: 100 °C or 212°F (1 deg scale)

MEASURING MICROWAVE ENERGY LEAKAGE

- **Pour 275±15cc of 20±5°C(68±9°F) water in a beaker which is graduated to 600 cc, and place the beaker on the oven.**
- **Set the energy leakage monitor to 2450 MHz and use it following the manufacturer's recommended test procedure to assure correct result.**
- **When measuring the leakage, always use the 2-inch (5cm) spacer supplied with the probe.**
- **Operate the oven at its maximum output.**
- **Measure the microwave radiation using and electromagnetic radiation monitor by holding the probe perpendicular to the surface being measured.**

Move probe along shaded area.

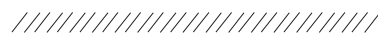

Probe scanning speed
Less than 2.5 cm/sec. (1 in/sec)

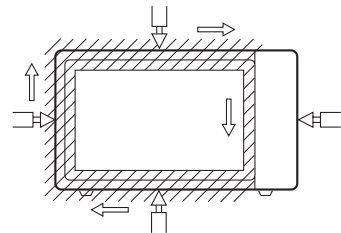

MEASUREMENT WITH THE OUTER CASE REMOVED

- (1) When you replace the magnetron, measure for microwave energy leakage before the outer case is installed and after all necessary components are replaced or adjusted. Special care should be taken in measuring the following parts.
 - Around the magnetron
 - The waveguide

WARNING: AVOID CONTACTING ANY HIGH VOLTAGE PARTS.

MEASUREMENT WITH A FULLY ASSEMBLED OVEN

- (1) After all components, including the outer panels, are fully assembled, measure for microwave energy leakage around the door viewing window, the exhaust opening and air inlet openings.
- (2) Microwave energy leakage must not exceed the values prescribed below.

NOTES:

Leakage with the outer panels removed than 5 mW/cm².

Leakage for a fully assembled oven (Before the latch switch (primary) is interrupted) with the door in a slightly opened position - less than 1 mW/cm²

NOTE WHEN MEASURING

- (1) Do not exceed meter full scale deflection.
- (2) The test probe must be removed no faster than 1 inch/sec (2.5cm/sec) along the shaded area, otherwise a false reading may result.
- (3) The test probe must be held with the grip portion of the handle. A false reading may result if the operator's hand is between the handle and the probe.
- (4) When testing near a corner of the door, keep the probe perpendicular to the surface making sure the probe horizontally along the oven surface, this may possibly cause probe damage.

RECORD KEEPING AND NOTIFICATION AFTER MEASUREMENT

- (1) After adjustment and repair of any microwave energy interruption or microwave energy blocking device, record the measured values for future reference. Also enter the information on the service invoice.
- (2) Should the microwave energy leakage not be more than 1 mW/cm² after determining that all parts are in good condition, functioning properly and genuine replacement parts which are listed in this manual have been used.
- (3) At least once a year, have the electromagnetic energy leakage monitor checked for calibration by its manufacturer.

8. POWER OUTPUT MEASUREMENT

- (1) Microwave power output measurement is made with the microwave oven supplied at its rated voltage and operated at its maximum microwave power setting with a load of (1000 ± 5) g of potable water.
- (2) The water is contained in a cylindrical borosilicate glass vessel having a maximum material thickness of 1/8" (3 mm) and an outside diameter of approximately 7.6" (190 mm).
- (3) The oven and the empty vessel are at ambient Temperature (T0) prior to the start of the test.
- (4) The initial temperature (T1) of the water is (10 ± 1) °C (50°F) It is measured immediately before the water is added to the vessel. After addition of the water to the vessel, the load is immediately placed on the center of the turntable which is in the lowest position and the microwave power switched on.
- (5) The time t for the temperature of the water to rise by a value T of (10 ± 1) °K is measured, where t is the time in seconds and T is the temperature rise. The initial and final water temperatures are selected so that the maximum difference between the final water temperature and the ambient temperature is 5°K.
- (6) The microwave power output P in watts is calculated from the following formula :

$$P = \frac{4.187 Mw(T2 - T1) + 0.55Mc(T2 - T0)}{t}$$

is measured while the microwave generator is operating at full power. Magnetron filament heat-up time is not included. (about 3 seconds)

- (7) The water is stirred to equalize temperature throughout the vessel, prior to measuring the final water temperature.
- (8) Stirring devices and measuring instruments are selected in order to minimize addition or removal of heat.

Where

P is the microwave power output, in watts

Mw is the mass of the water, in grams

Mc is the mass of the container, in grams

T0 is the ambient temperature, in °C

T1 is the initial temperature of the water, in °C

T2 is the final temperature of the water, in °C

t is the heating time in seconds, excluding the magnetron filament heat-up time.

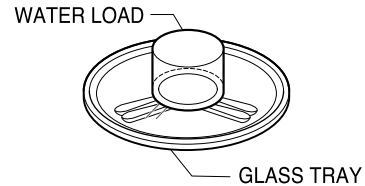

9. INTERLOCK SYSTEM

9-1. Interlock Mechanism

The door lock mechanism is a device which has been specially designed to eliminate completely microwave activity when the door is opened during cooking and thus to prevent the danger resulting from the microwave leakage.

ADJUSTMENT PROCEDURES

To avoid possible exposure to microwave energy leakage, adjust the door latches and interlock switches, using the following procedure.

The Interlock Monitor and Primary Interlock Switch act as the final safety switch protecting the user from microwave energy. The terminals between COM and NC of the Interlock Monitor must close when the door is opened. After adjusting the Interlock Monitor Switch, make sure that it is correctly connected. Mounting of the primary/monitor/secondary switches to the latch board.

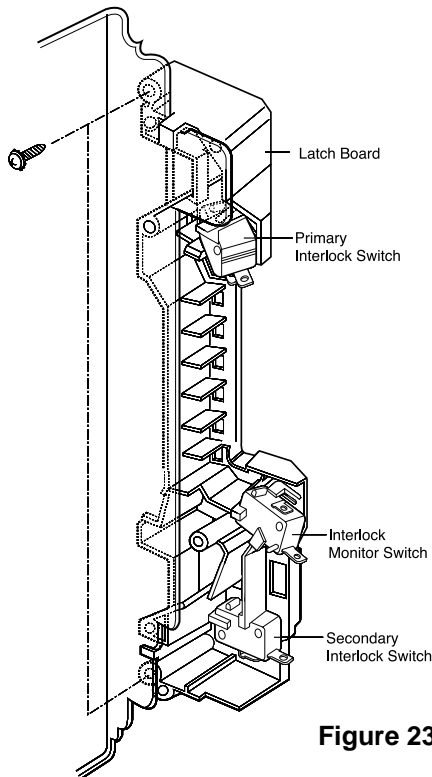

Figure 23-a

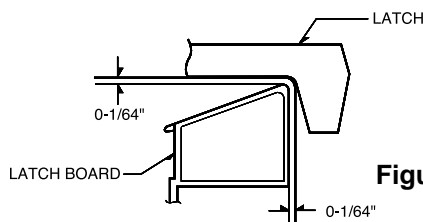

Figure 23-b

CHECK THE DOOR LATCH AND SWITCH CLOSING.

NOTE:

The outer cover of the microwave oven is removed.

- (1) Set the microwave oven on its side so that you can see the latch board and the switches, as shown in Figure 23-a.
- (2) Close the door tightly and check gaps A and B to be sure they are no more than 1/64" (0.5 mm). See Figure 23-b for close-up view of gaps A and B (door latches). If all gaps are less than 1/64" (0.5 mm), adjustment of the latch board may not be necessary. Go to Steps 5 and 6 to check the sequence of the switches.

NOTE:

To correct sequence of the Primary Interlock Switch, Secondary Interlock Switch and the Interlock Monitor Switch is very important. **If any gap is larger than 1/64" (0.5 mm), you will need to adjust the latch board. Go to step 3 and follow all steps in order.**

ADJUST THE LATCH AND SWITCH CLOSING

- (3) Loosen the two screws holding the plastic latch board as shown.
- (4) With the oven door closed tightly, move the latch board upward toward the top of the oven and/or away from the door latch until the gaps are less than 1/64" (0.5 mm). Hold the latch board tightly in this position until you check the sequence of the switches in steps 5 and 6.

TEST THE LATCH AND SWITCH SEQUENCE

- (5) Open the oven door slowly. Watch the door latch, the Secondary Switch. Release Rod and Lever on the switches to make sure they are zero to the body of the switches in the following sequence:

- Primary Interlock Switch
- Secondary Interlock Switch
- Interlock Monitor Switch

Adjust the latch board until the switches operate in this sequence. See Steps 3 and 4.

- (6) Close the oven door slowly and be sure it is tightly closed. Watch the three switches to make sure they are zero to the body of the switches in the following sequence:

- Interlock Monitor Switch
- Primary Interlock Switch
- Secondary Interlock Switch

NOTE: The Interlock Monitor Switch is an added safety check on the Primary and Secondary Interlock Switches. If the Primary and Secondary Interlock Switches allow the oven to operate with the door open, the Monitor Switch will blow the fuse.

- (7) When you achieve the proper sequence of switches in Steps 5 and 6, tighten the latch board screws at that point.

TEST THE MICROWAVE ENERGY LEAKAGE

Make sure the microwave energy leakage is below the limit of $1\text{mW}/\text{cm}^2$ (with a 275 ml water load) and $5\text{mW}/\text{cm}^2$ (with a 275 ml water load without the cabinet) when measured with a survey meter.

9-2. Interlock Continuity Test

A. PRIMARY INTERLOCK SWITCH TEST

When the door is opened slowly, an audible **click** should be heard at the same time or successively at intervals and the latches should activate the switches with an audible **click**.

If the latches do not activate the switches when the door is closed, the switches should be adjusted in accordance with the adjustment procedure.

Disconnect the wire lead from the primary switch. Connect the ohmmeter leads to the common (COM) and normally open (NO) terminal of the switch. The meter should indicate an open circuit in the door open condition.

When the door is closed, the meter should indicate a closed circuit.

When the primary switch operation is abnormal, make the necessary adjustment or replace the switch only with the same type of switch.

B. SECONDARY INTERLOCK SWITCH TEST







Disconnect the wire lead from the secondary switch.

Connect the ohmmeter leads to the common (COM) and normally open (NO) terminals of the switch. The meter should indicate an open circuit in the door open condition. When the door is closed, the meter should indicate a closed circuit. When the secondary switch operation is abnormal, make the necessary adjustment or replace the switch only with the same type of switch.

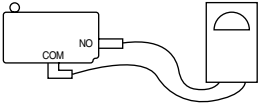
C. MONITOR SWITCH TEST

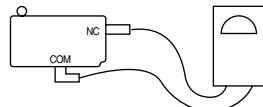
Disconnect the wire lead from the monitor switch. Connect the ohmmeter leads to the common (COM) and normally closed (NC) terminals of the switch. The meter should indicate a closed circuit in the door open condition. When the door is closed, the meter should indicate an open circuit. When the monitor switch operation is abnormal, replace with the same type of switch.

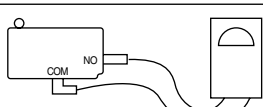
NOTE: After repairing the door or the interlock system, it is necessary to do this continuity test before operating the oven.

COMPONENTS	TEST PROCEDURE		RESULTS	
			Door open	Door closed
SWITCHES (Wire leads removed)	Check for continuity of the switch with an Ohm-meter			
	Primary Switch			
	Monitor Switch			
	Secondary Switch			
NOTE : After checking for the continuity of switches, make sure that they are connected correctly.				

WARNING : FOR CONTINUED PROTECTION AGAINST EXCESSIVE RADIATION EMISSION, REPLACE ONLY WITH IDENTICAL REPLACEMENT PARTS.

TYPE NO.SZM-V16-FA-63 OR VP-533A-OF OR V-5230Q FOR PRIMARY SWITCH

TYPE NO.SZM-V16-FA-62 OR VP-532A-OF OR V-5220Q FOR MONITOR SWITCH

TYPE NO.SZM-V16-FA-63 OR VP-533A-OF OR V-5230Q FOR SECONDARY SWITCH



10. COMPONENT TESTING INFORMATION

CAUTIONS

1. DISCONNECT THE POWER SUPPLY CORD FROM THE OUTLET WHENEVER REMOVING THE OUTER CASE FROM THE UNIT. PROCEED WITH THE TEST ONLY AFTER DISCHARGING THE HIGH VOLTAGE CAPACITOR AND REMOVING THE LEAD WIRES FROM THE PRIMARY WINDING OF THE HIGH VOLTAGE TRANSFORMER.
2. ALL OPERATIONAL CHECKS WITH MICROWAVE ENERGY MUST BE DONE WITH A LOAD (1 LITER OF WATER IN CONTAINER) IN THE OVEN.

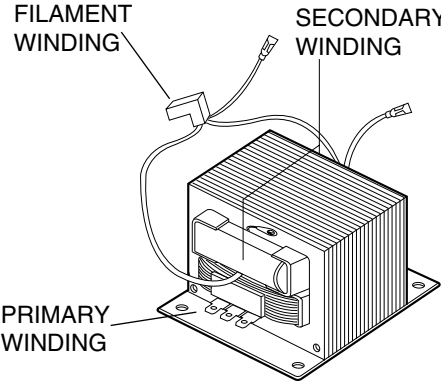
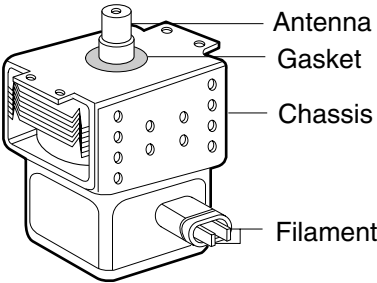
A. TEST PROCEDURES

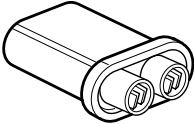
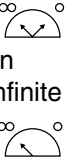
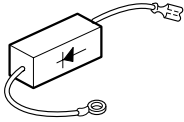
COMPONENTS	TEST	RESULTS
<p>TRANSFORMER</p>	 <ol style="list-style-type: none"> 1. Remove wire leads. 2. Measure resistance. (ohm meter scale: Rx1) <ul style="list-style-type: none"> • Primary winding <ul style="list-style-type: none"> High Low • Secondary winding • Filament winding 3. Measure resistance. (ohm meter scale: Rx1000) <ul style="list-style-type: none"> • Primary winding to ground • Filament winding to ground 	<p>Approx. 0.2 to 0.5 ohms Approx. 0.2 to 0.5 ohms Approx. 50 to 120 ohms 0 ohm</p> <p>Normal: Infinite Normal: Infinite</p>
<p>MAGNETRON</p>	 <ol style="list-style-type: none"> 1. Remove wire leads. Install the magnetron seal in the correct position. Check that the seal is in good condition. 2. Measure resistance. (ohm meter scale: Rx1) <ul style="list-style-type: none"> • Filament terminal 3. Measure resistance. (ohm meter scale: Rx1000) <ul style="list-style-type: none"> • Filament to chassis 	<p>Normal: Less than 1 ohm</p> <p>Normal: Infinite</p>

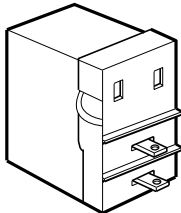
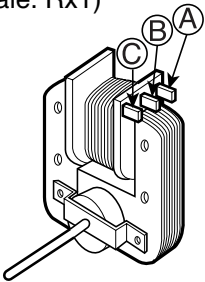
COMPONENTS	TEST	RESULTS																																	
<p>CAPACITOR</p>	<p>1. Remove wire leads. 2. Measure resistance. (ohm meter scale: Rx1000)</p> <ul style="list-style-type: none"> • Terminal to terminal • Terminal to case 	<p>Normal: Momently indicates several ohm, and then gradually returns to infinite Normal: Infinite.</p> 																																	
<p>DIODE Some inexpensive ohm meters may indicate infinite resistance in both directions.</p>	<p>1. Measure continuity. Forward. (ohm meter scale: Rx1000) 2. Measure continuity. Reverse. (ohm meter scale: Rx1000)</p> 	<p>Normal: Continuity. Abnormal: Infinite.</p>  <p>Normal: Infinite. Abnormal: Continuity.</p> 																																	
<p>RELAY 10</p>	<p>1. Measure continuity. (ohm meter scale: Rx1) 2. Remove the lead wires and operate oven at power level 1 through power level 10.</p> 	<table border="1"> <thead> <tr> <th>Power Level</th> <th>Open</th> <th>Close</th> </tr> </thead> <tbody> <tr><td>1</td><td>4 Sec</td><td>18 Sec</td></tr> <tr><td>2</td><td>6 Sec</td><td>16 Sec</td></tr> <tr><td>3</td><td>8 Sec</td><td>14 Sec</td></tr> <tr><td>4</td><td>10 Sec</td><td>12 Sec</td></tr> <tr><td>5</td><td>12 Sec</td><td>10 Sec</td></tr> <tr><td>6</td><td>14 Sec</td><td>8 Sec</td></tr> <tr><td>7</td><td>16 Sec</td><td>6 Sec</td></tr> <tr><td>8</td><td>18 Sec</td><td>4 Sec</td></tr> <tr><td>9</td><td>20 Sec</td><td>2 Sec</td></tr> <tr><td>10</td><td>22 Sec</td><td>0 Sec</td></tr> </tbody> </table>	Power Level	Open	Close	1	4 Sec	18 Sec	2	6 Sec	16 Sec	3	8 Sec	14 Sec	4	10 Sec	12 Sec	5	12 Sec	10 Sec	6	14 Sec	8 Sec	7	16 Sec	6 Sec	8	18 Sec	4 Sec	9	20 Sec	2 Sec	10	22 Sec	0 Sec
Power Level	Open	Close																																	
1	4 Sec	18 Sec																																	
2	6 Sec	16 Sec																																	
3	8 Sec	14 Sec																																	
4	10 Sec	12 Sec																																	
5	12 Sec	10 Sec																																	
6	14 Sec	8 Sec																																	
7	16 Sec	6 Sec																																	
8	18 Sec	4 Sec																																	
9	20 Sec	2 Sec																																	
10	22 Sec	0 Sec																																	
<p>FAN MOTOR</p>	<p>1. Remove wire leads. 2. Measure resistance. (ohm meter scale: Rx1)</p> 	<p>Normal: Approximately Terminal Ⓐ-Ⓒ 35 to 50 ohms Terminal Ⓐ-Ⓑ 5 to 15 ohms Abnormal: Infinite or several.</p>																																	

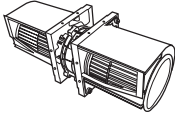
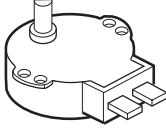
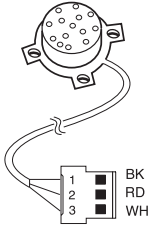
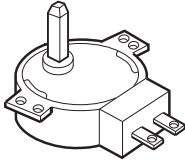
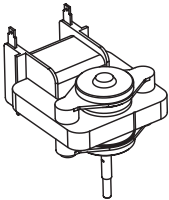
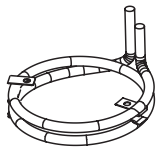
COMPONENTS	TEST	RESULTS
VENTILATION MOTOR	1.Remove lead wires. 2.Measure resistance. (ohm meter scale: Rx1) 	Normal: Approximately 20 to 40 ohms Abnormal: Infinite
TURNTABLE MOTOR	1. Remove wire leads. 2. Measure resistance. (ohm meter scale: Rx1000) 	Normal: Approximately 2.0 to 3.0 Kohms Abnormal: Infinite or several.
ABSOLUTE HUMIDITY SENSOR	1. Disconnect sensor connector from micom computer board. 2. Measure resistance terminal to terminal (ohm meter scale: R X 1000) 	Normal: Approximately BK-RD: 6.0 Kohms RD-WH: 3.0 Kohms BK-WH: 3.0 Kohms Abnormal: Infinite or approx. 0 ohm
STIRRER MOTOR	1.Remove lead wires. 2.Measure resistance. (ohm meter scale: Rx1000) 	Normal: Approximately 120 to 135 ohms Abnormal: Infinite
CIRCULATION MOTOR	1. Remove lead wires. 2. Measure resistance. (ohm meter scale: Rx1) 	Normal: Approximately 55 to 70 ohms Abnormal: Infinite
HEATER	1. Remove lead wires. 2. Measure resistance. (ohm meter scale: Rx1) 	Normal: Approximately 20 to 30 ohms Abnormal: Infinite

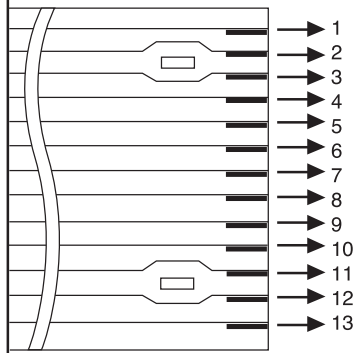
COMPONENTS	TEST	RESULTS																																																													
<p>TOUCH KEY BOARD</p>	<p>Measure the resistance between terminal pins of connector KEY CONNECTOR. NOTE: When reconnecting the FPC connector, make sure that the holes on the FPC connector are properly engaged with hooks on the plastic fastener.</p> <p style="text-align: center;">MATRIX CIRCUIT FOR TOUCH KEY BOARD</p> <p style="text-align: center;">CONNECTOR(KEY CON)</p> <table border="1" style="margin-left: auto; margin-right: auto;"> <tr> <td></td> <td>1</td> <td>2</td> <td>3</td> <td>4</td> <td>5</td> <td>6</td> <td>7</td> </tr> <tr> <td>8</td> <td>N.C</td> <td>COOK TIME</td> <td>N.C</td> <td>N.C</td> <td>N.C</td> <td>N.C</td> <td>N.C</td> </tr> <tr> <td>9</td> <td>VENT ON/OFF</td> <td>VENT 5-SPEED</td> <td>LIGHT HI/LOW/OFF</td> <td>MAC & CHEESE</td> <td>AUTO TIME SET</td> <td>SOFTEN</td> <td>MELT</td> </tr> <tr> <td>10</td> <td>SENSOR POPCORN</td> <td>SENSOR COOK</td> <td>SENSOR REHEAT</td> <td>DEFROST</td> <td>EZ-ON</td> <td>HOT DOG</td> <td>CHICKEN NUGGETS</td> </tr> <tr> <td>11</td> <td>CUSTOM SET</td> <td>WARMING LAMP</td> <td>N.C</td> <td>N.C</td> <td>CLOCK</td> <td>MORE</td> <td>LESS</td> </tr> <tr> <td>12</td> <td>POWER LEVEL</td> <td>N.C</td> <td>STOP/CLEAR</td> <td>START/ENTER</td> <td>8</td> <td>9</td> <td>0</td> </tr> <tr> <td>13</td> <td></td> <td></td> <td></td> <td></td> <td></td> <td></td> <td></td> </tr> </table>		1	2	3	4	5	6	7	8	N.C	COOK TIME	N.C	N.C	N.C	N.C	N.C	9	VENT ON/OFF	VENT 5-SPEED	LIGHT HI/LOW/OFF	MAC & CHEESE	AUTO TIME SET	SOFTEN	MELT	10	SENSOR POPCORN	SENSOR COOK	SENSOR REHEAT	DEFROST	EZ-ON	HOT DOG	CHICKEN NUGGETS	11	CUSTOM SET	WARMING LAMP	N.C	N.C	CLOCK	MORE	LESS	12	POWER LEVEL	N.C	STOP/CLEAR	START/ENTER	8	9	0	13								<table border="1" style="margin-left: auto; margin-right: auto;"> <tr> <td rowspan="2" style="text-align: center;">Resistance value</td> <td style="text-align: center;">When touched</td> <td style="text-align: center;">When not touched</td> </tr> <tr> <td style="text-align: center;">Less than 400 ohms</td> <td style="text-align: center;">More than 1 megohm</td> </tr> </table> <p style="text-align: center;">FPC CONNECTOR Top</p> 	Resistance value	When touched	When not touched	Less than 400 ohms	More than 1 megohm
	1	2	3	4	5	6	7																																																								
8	N.C	COOK TIME	N.C	N.C	N.C	N.C	N.C																																																								
9	VENT ON/OFF	VENT 5-SPEED	LIGHT HI/LOW/OFF	MAC & CHEESE	AUTO TIME SET	SOFTEN	MELT																																																								
10	SENSOR POPCORN	SENSOR COOK	SENSOR REHEAT	DEFROST	EZ-ON	HOT DOG	CHICKEN NUGGETS																																																								
11	CUSTOM SET	WARMING LAMP	N.C	N.C	CLOCK	MORE	LESS																																																								
12	POWER LEVEL	N.C	STOP/CLEAR	START/ENTER	8	9	0																																																								
13																																																															
Resistance value	When touched	When not touched																																																													
	Less than 400 ohms	More than 1 megohm																																																													

NOTES:

- A MICROWAVE ENERGY TEST MUST ALWAYS BE PERFORMED WHEN THE UNIT IS SERVICED FOR ANY REASON.
- MAKE SURE THE WIRE LEADS ARE IN THE CORRECT POSITION.
- WHEN REMOVING THE WIRE LEADS FROM THE PARTS, BE SURE TO GRASP THE CONNECTOR, NOT THE WIRES.

11. DISASSEMBLY INSTRUCTIONS

IMPORTANT NOTES:

UNIT MUST BE DISCONNECTED FROM ELECTRICAL OUTLET WHEN MAKING REPAIRS, REPLACEMENTS, ADJUSTMENTS AND CONTINUITY CHECKS.

WHEN RECONNECTING THE WIRE LEADS TO ANY PART, MAKE SURE THE WIRING CONNECTIONS AND LEAD COLORS ARE CORRECTLY MATCHED ACCORDING TO THE OVERALL CIRCUIT DIAGRAM. (ESPECIALLY SWITCHES AND HIGH VOLTAGE CIRCUIT.)

A. REMOVING POWER AND CONTROL CIRCUIT BOARD (Figures 1, 2 and, 3)

- (1) Remove a screw securing the control panel assembly to the oven cavity.
- (2) Remove the control panel with pushing it upward.
- (3) Remove the connectors (CN1, CN3, CN6, CN7) and wire leads (3 Tap Power Relay, RY8) from the circuit board.

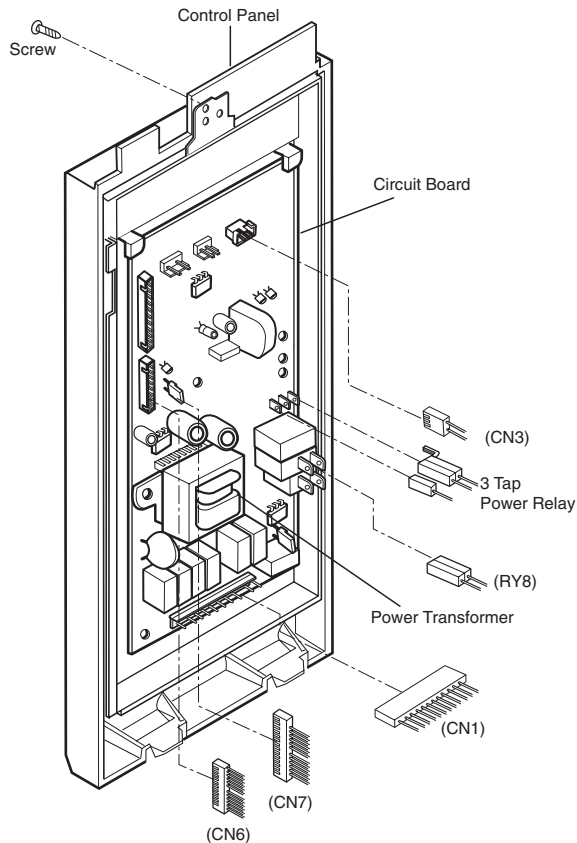

Figure 1

- (4) Remove 3 screws securing the circuit board.

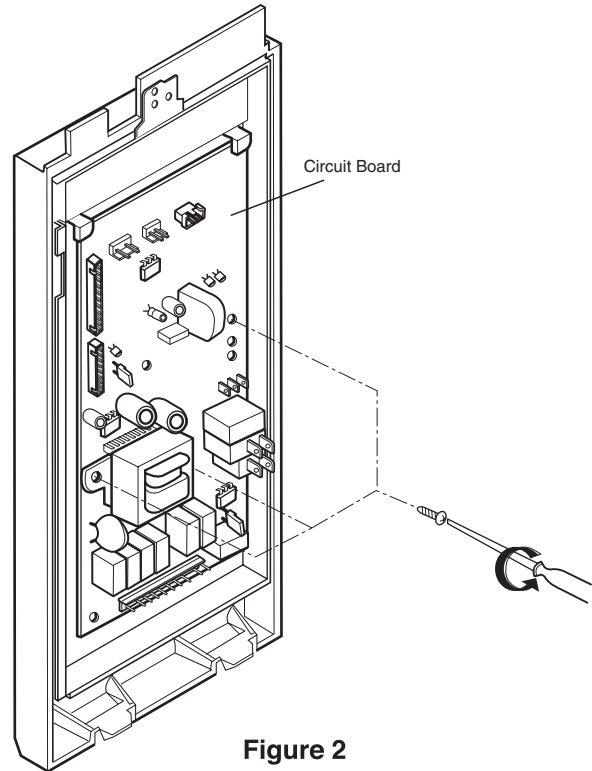

Figure 2

- (5) Remove the FPC connector from the terminal socket following HOW TO REMOVE THE FPC CONNECTOR on the next page.
- (6) Remove the circuit board from the control bracket carefully.

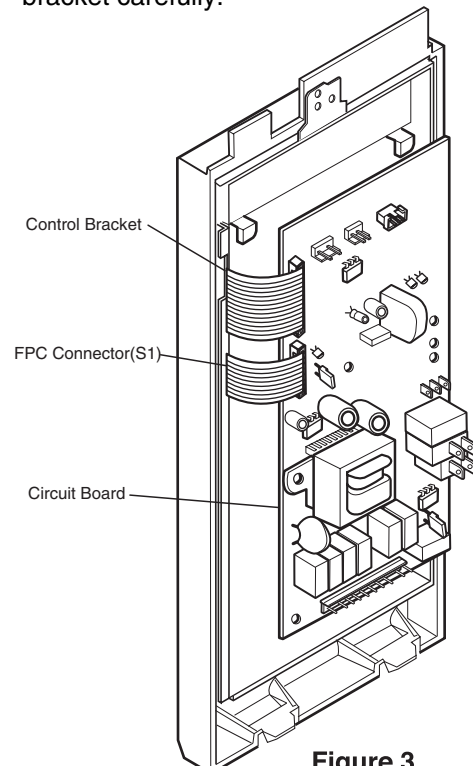

Figure 3

HOW TO REMOVE THE F.P.C. CONNECTOR

Follow the steps below as illustrated in Figures 4 and 5 to remove the F.P.C. connector.

- (1) Hold the edges of the plastic fastener with thumb and forefinger.
(Figure 4)
- (2) Lift up the lever of the plastic fastener from the terminal socket by lightly pressing the lever end with forefinger.
(Figure 5)
- (3) Remove the F.P.C. connector from the terminal socket.

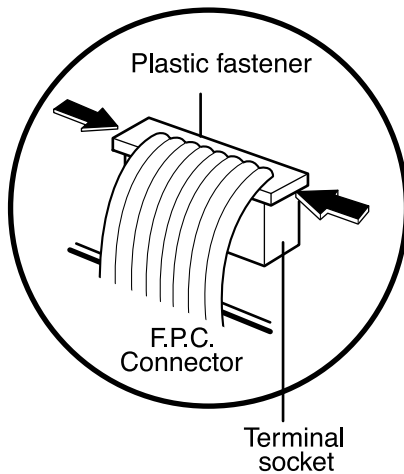

Figure 4

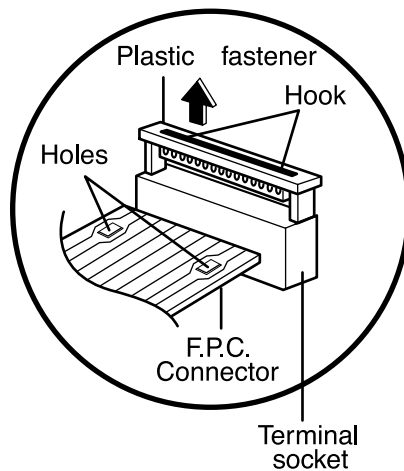

Figure 5

HOW TO INSERT THE F.P.C. CONNECTOR

Follow the steps below as illustrated in Figures 6 and 7 to insert the F.P.C. connector.

- (1) Insert the F.P.C. connector into the terminal socket securely with the fingers.
- (2) Hold the plastic fastener with thumb and forefinger of the other hand, and push it slowly into the terminal socket. (Figure 6)

NOTE: When reconnecting the F.P.C. connector make sure that the holes on the F.P.C. connector are properly engaged with the hooks on the plastic fastener

- (3) Lock the level of the plastic fastener into the hook of the terminal socket securely by releasing the fingers.
(Figure 7)

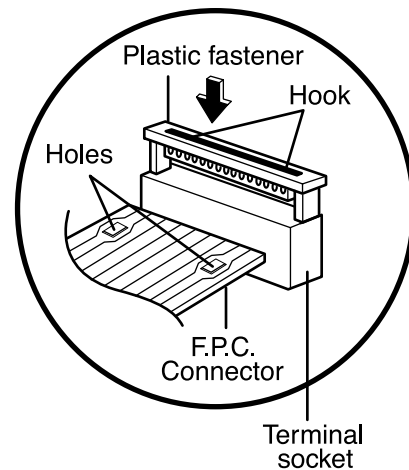

Figure 6

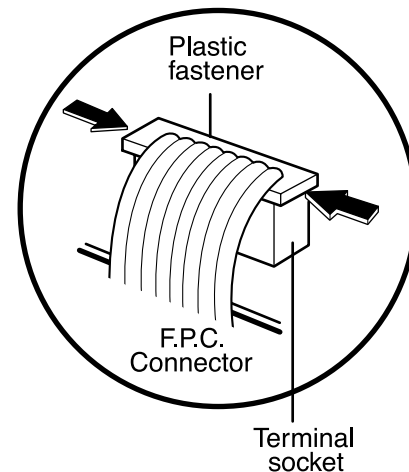

Figure 7

B. REMOVING THE OUT CASE(Figure 8)

- (1) Remove the vent grille by removing two screws securing it to the outer case.
- (2) Remove two screws securing it to the air duct.
- (3) Remove the mounting plate by turning the screws (1 or 2 screws) securing it to the outer case.
- (4) Remove two screws on the left central edge and two screws on the right central edge of the base plate.

Remove the fan bracket from the outer case by removing one screw securing it to the outer case.

- (5) Remove four screws of the rear cavity.
- (6) Remove the outcase with disconnecting power cord connector.

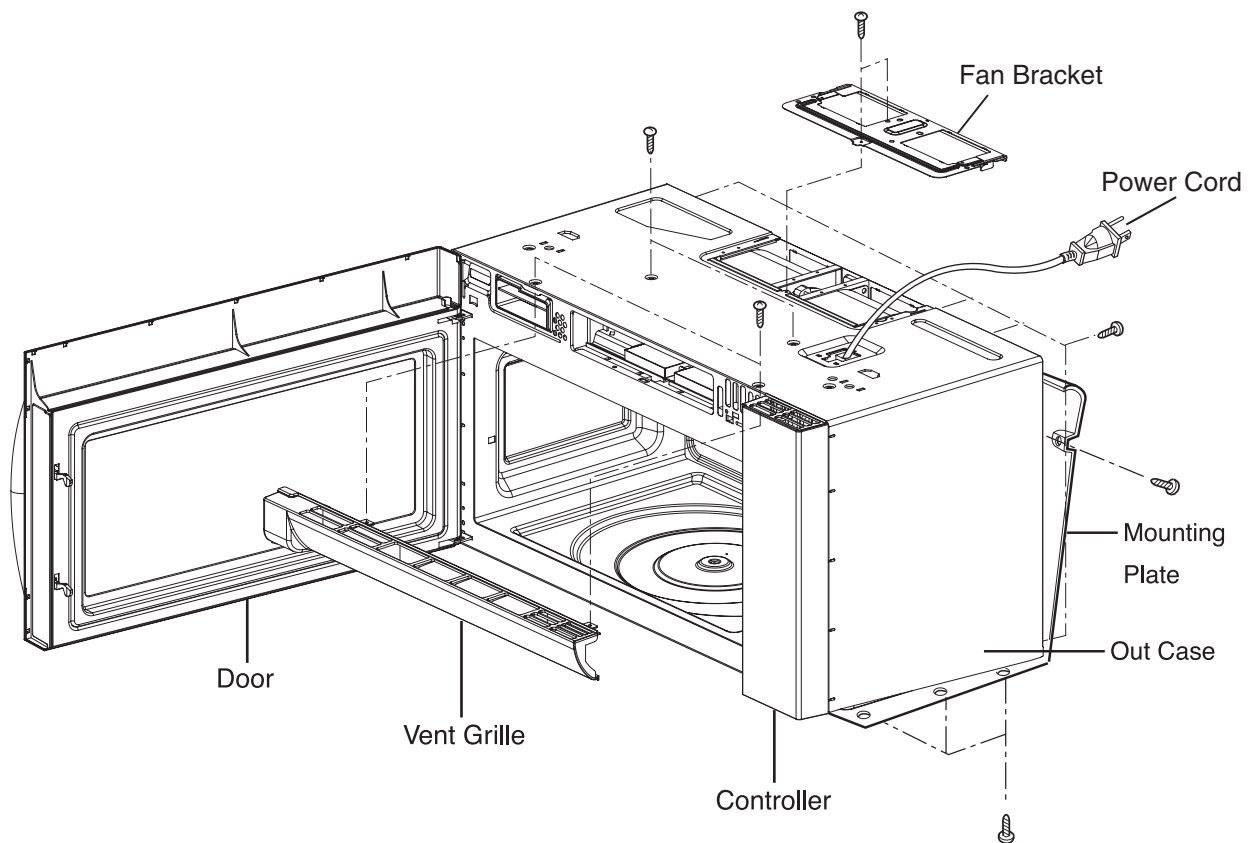

Figure 8

C REMOVING THE DOOR INTERLOCK SWITCHES (Figures 9,10)

- (1) Disconnect the wire leads from the interlock switches.
- (2) Remove two screws securing the Latch Board.
- (3) Make necessary replacements and check microwave energy leakage according to ADJUSTMENT PROCEDURES on page 7-12.

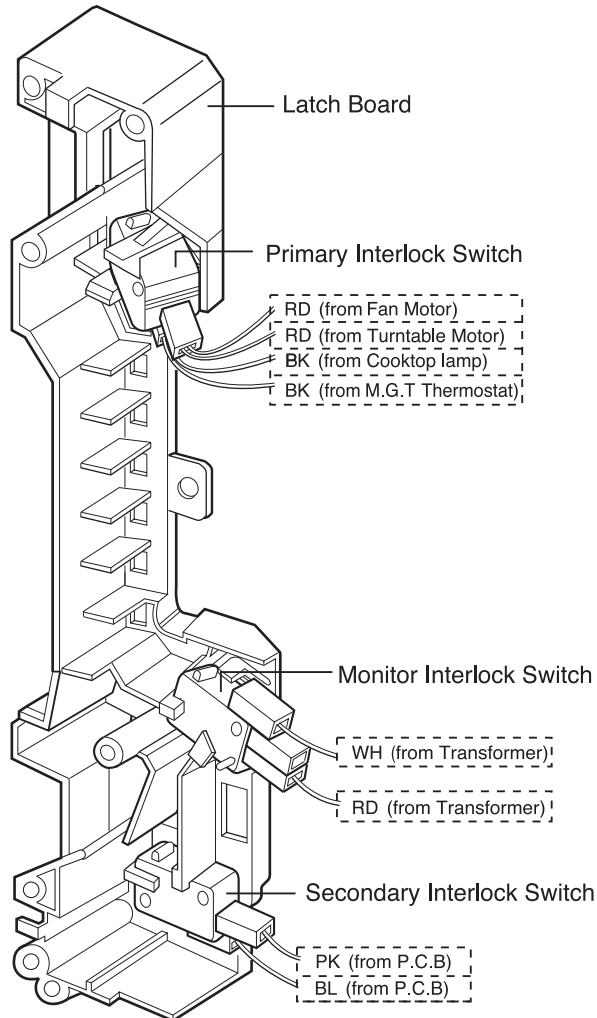

Figure 9

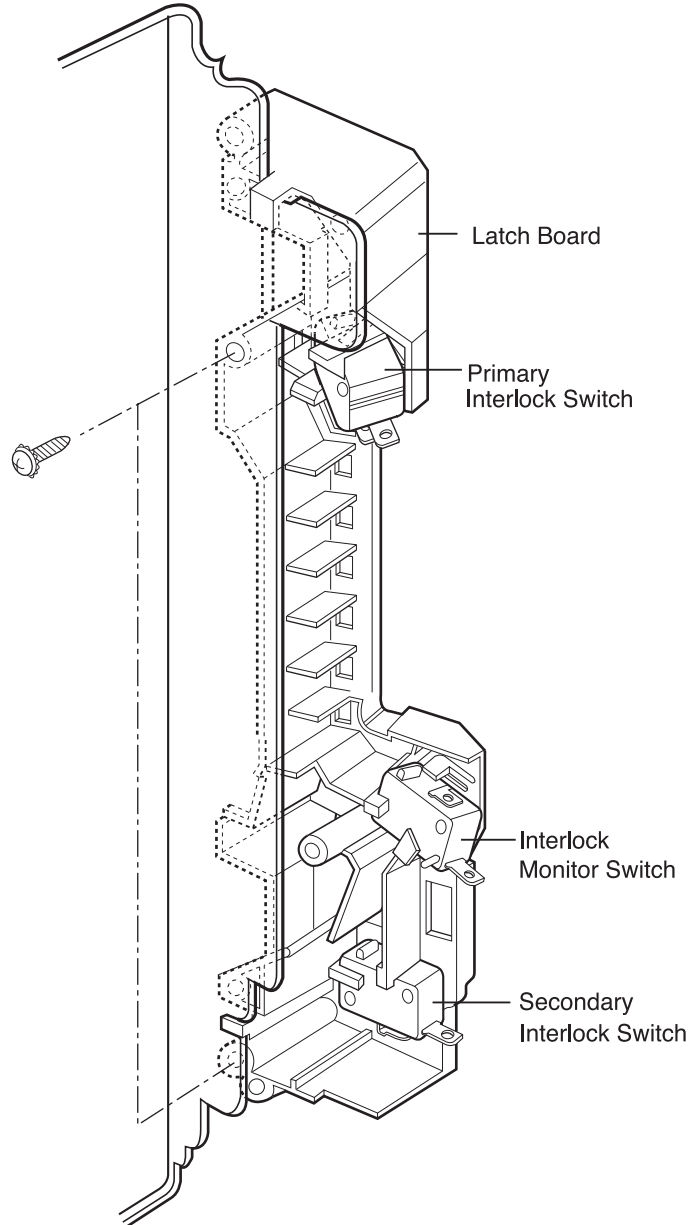

Figure 10

WIRE COLOR

SYMBOL	COLOR
WH	WHITE
BK	BLACK
BR	BROWN
RD	RED
YL	YELLOW
PK	PINK
BL	BLUE
GY	GREY
GN	GREEN
N.P.	Not Provided

D. REMOVING MAGNETRON

(Figures 11 Through 12)

- (1) Remove the vent grille by loosening two screws. (Figure 11)
- (2) Remove the outcase. See page 7-6.
- (3) Remove four tap tite screws securing the magnetron to the wave guide.
- (4) Remove the magnetron VERY CAREFULLY.

NOTES:

- When removing the magnetron, make sure that its dome does not hit any adjacent parts, or it may be damaged.
- When replacing the magnetron, be sure to install the magnetron gasket in the correct position and be sure that the gasket is in good condition.
- After replacing the magnetron, check for microwave energy leakage with a survey meter. Check microwave energy leakage must be below the limit of 5 mW/cm^2 . (All service adjustments should be made for minimum microwave energy leakage readings.)

E. REMOVING STIRRER FAN

(Figures 13 and 14)

- (1) Remove one rivet assembly securing it to the oven upper plate by using knife blade.
- (2) Pull out the stirrer fan cover.
- (3) Remove two rivets assembly securing it to the oven upper plate by using knife blade.
- (4) Remove the stirrer fan.

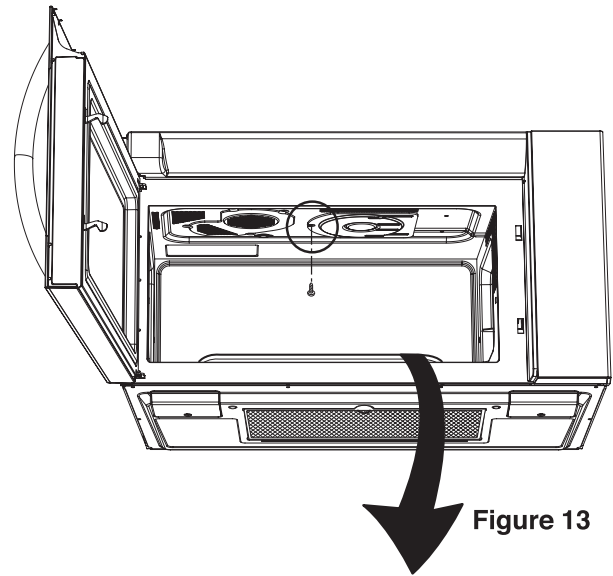

Figure 13

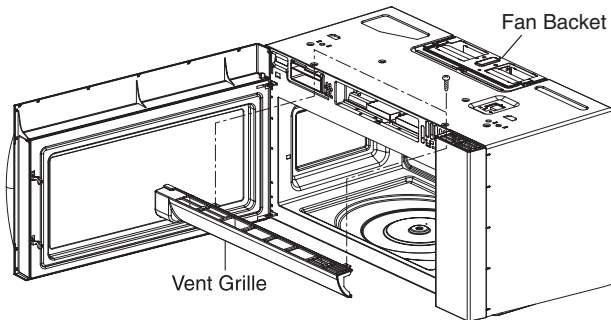

Figure 11

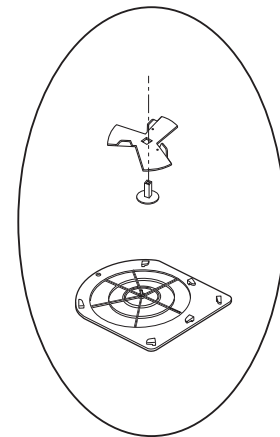

Figure 14

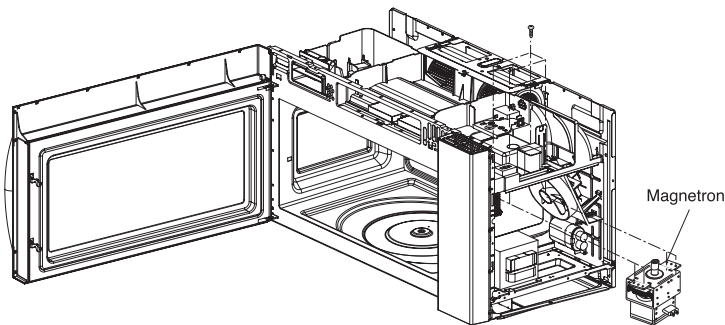

Figure 12

F. REMOVING DOOR (Figure 15)

- (1) Remove the vent grille by two screws securing it to the outcase loosening.
- (2) Lift up and draw the door.

NOTES:

- After replacing the door, be sure to check that the primary interlock switch, the secondary interlock switch and the interlock monitor switch is in good operating normally.
- After replacing the door, check for microwave energy leakage with a survey meter. Microwave energy leakage must be below the limit of $5\text{mW}/\text{cm}^2$. (With a 275 ml water load).

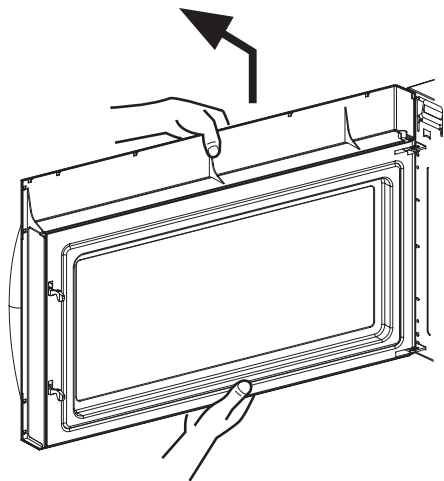

Figure 15

G. DISASSEMBLING DOOR (Figure 16)

- (1) Remove the dielectric choke by using knife blade or small screw driver, etc.
- (2) Remove two screws securing it to the door handle.

CAUTION: Be careful not to damage door seal plate with the screwdriver.

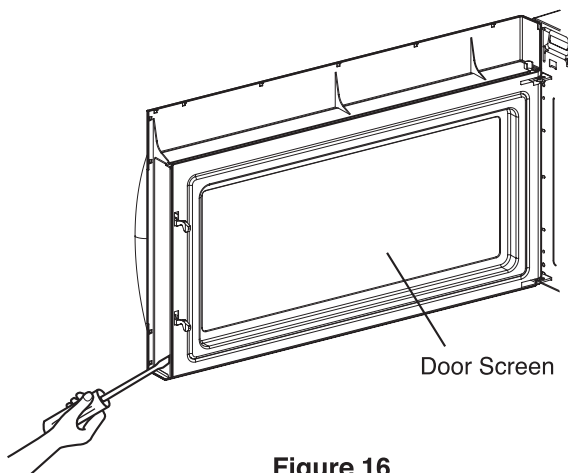
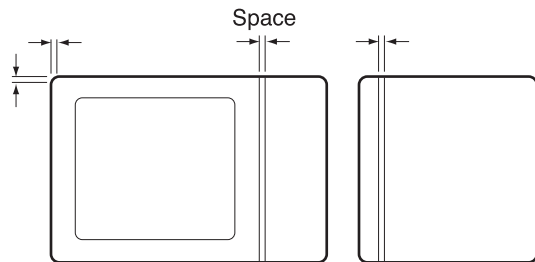

Figure 16

H. ASSEMBLING DOOR

- (1) When mounting the door assembly to the oven assembly, be sure to adjust the door assembly parallel to the chassis. Also adjust so the door has no play between the inner door surface and oven frame assembly. If the door assembly is not mounted properly, microwaves may leak from the clearance between the door and the oven.



I. REMOVING THE VENTILATION MOTOR

- (1) Remove the mounting plate by loosening mounting plate screws (1 or 2 screws) securing it to the back plate. (See Figure 17)
- (2) Remove the fan bracket loosening two screw loosening two screw securing the ventilation motor and back plate. (See Figure 18-a)

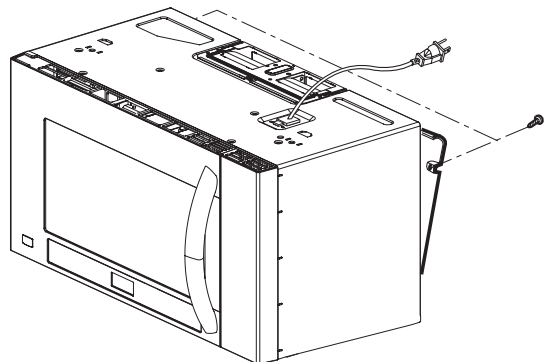

Figure 17

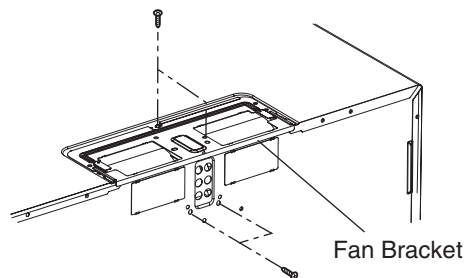

Figure 18-a

- (3) Carefully pull the ventilation motor assembly out of the microwave oven. (See Figure 18-b)

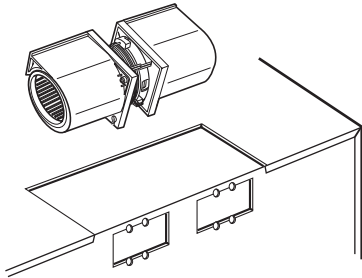

Figure 18-b

J. REMOVING THE TURNTABLE MOTOR

- (1) Remove the glass tray and rotating ring.
- (2) Remove the turntable shaft VERY CAREFULLY with a hand. (Figure 19)
- (3) Remove the base plate by removing 8 screws securing it to the oven cavity. (Figure 20)
- (4) Disconnect the leadwire from the turntable motor terminals.
- (5) Remove the 1 screw securing the turntable motor to the oven cavity assembly. (Figure 21)

NOTES:

- Remove the leadwire from the turntable motor VERY CAREFULLY.
- Be sure to grasp the connector, not the wires, when removing.

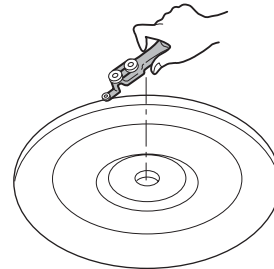

Figure 19

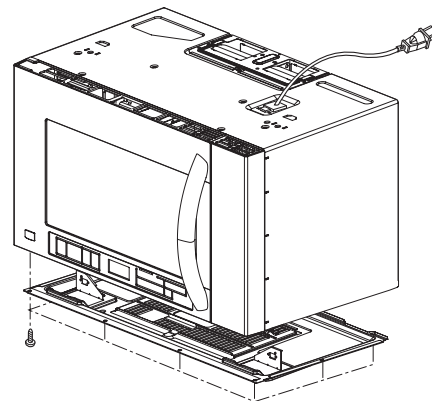

Figure 20

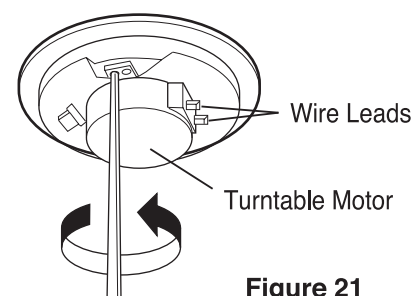

Figure 21

K. REPLACING THE HUMIDITY SENSOR

- (1) Remove the sensor by removing one screw securing it to the air duct. (See Figure 22)
- (2) Mount the new humidity sensor to the air duct.

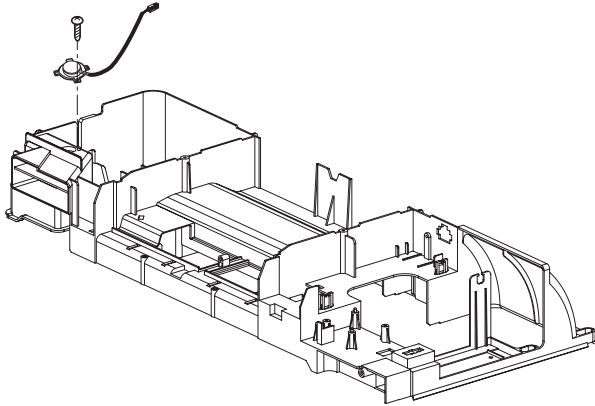

Figure 22

L. REMOVING CONVECTION HEATER AND THERMISTOR (Figure 23)

- (1) Remove the out case.
- (2) Remove the air duct by removing six screws securing it to the oven front plate, guide air and glasswool-L cover.
- (3) Disconnect the wire leads of fan motor.
- (4) Disconnect the wire leads of heater and C-motor.
- (5) Remove the thermistor by removing one screw.
- (6) Remove the four net screws securing chamber assembly.
- (7) Lift the chamber assembly from the oven cavity.
- (8) Remove three screws securing the heater of the chamber assembly.
- (9) Lift the convection heater from the chamber assembly.

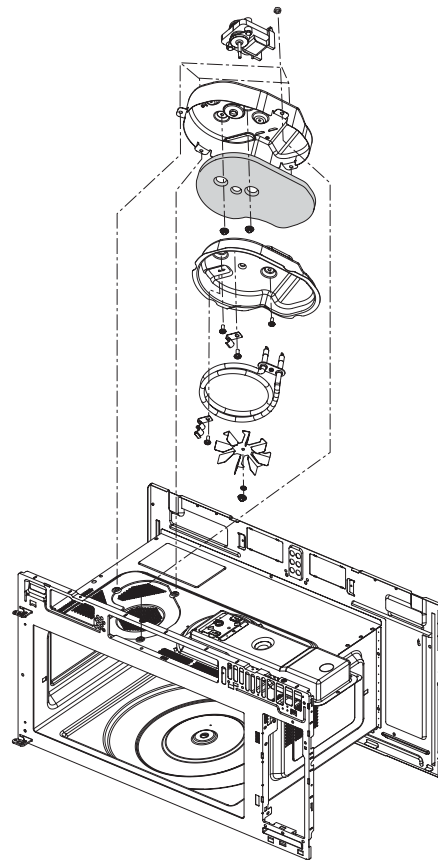
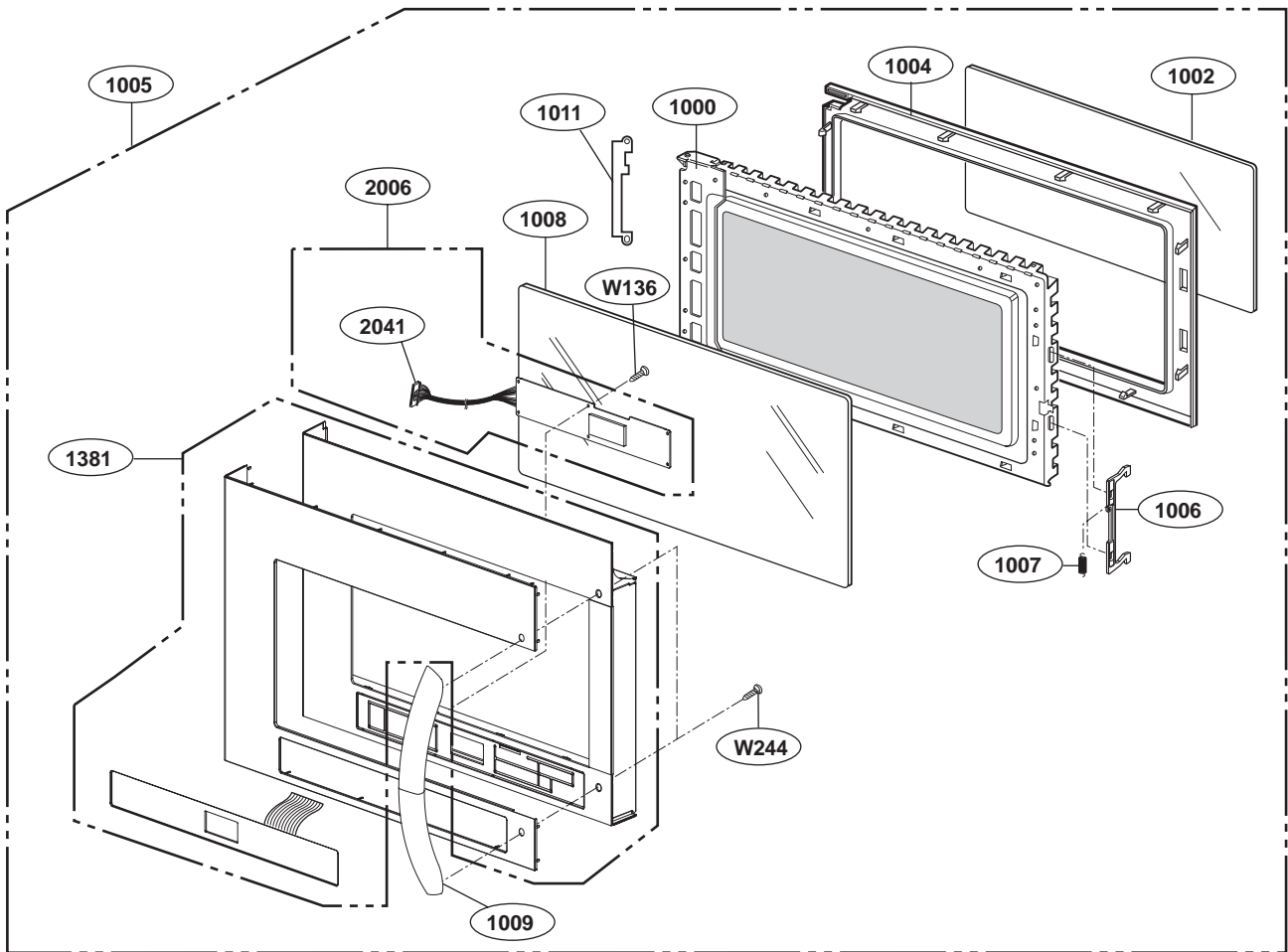

Figure 23

DOOR PARTS (II)

FOR MODEL: LMVM2085ST



CONTROLLER PARTS (II)

FOR MODEL: LMVM2085ST

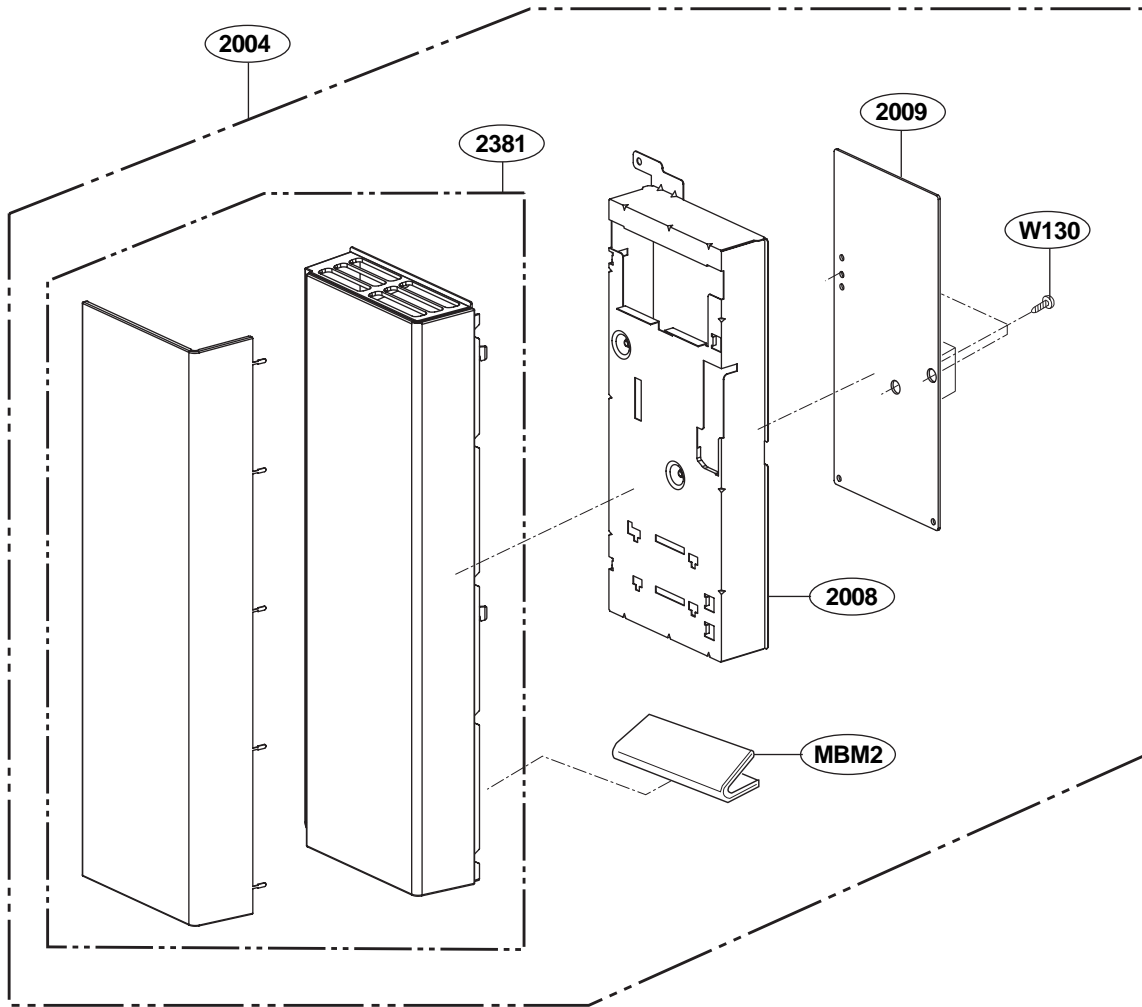

OVEN CAVITY PARTS

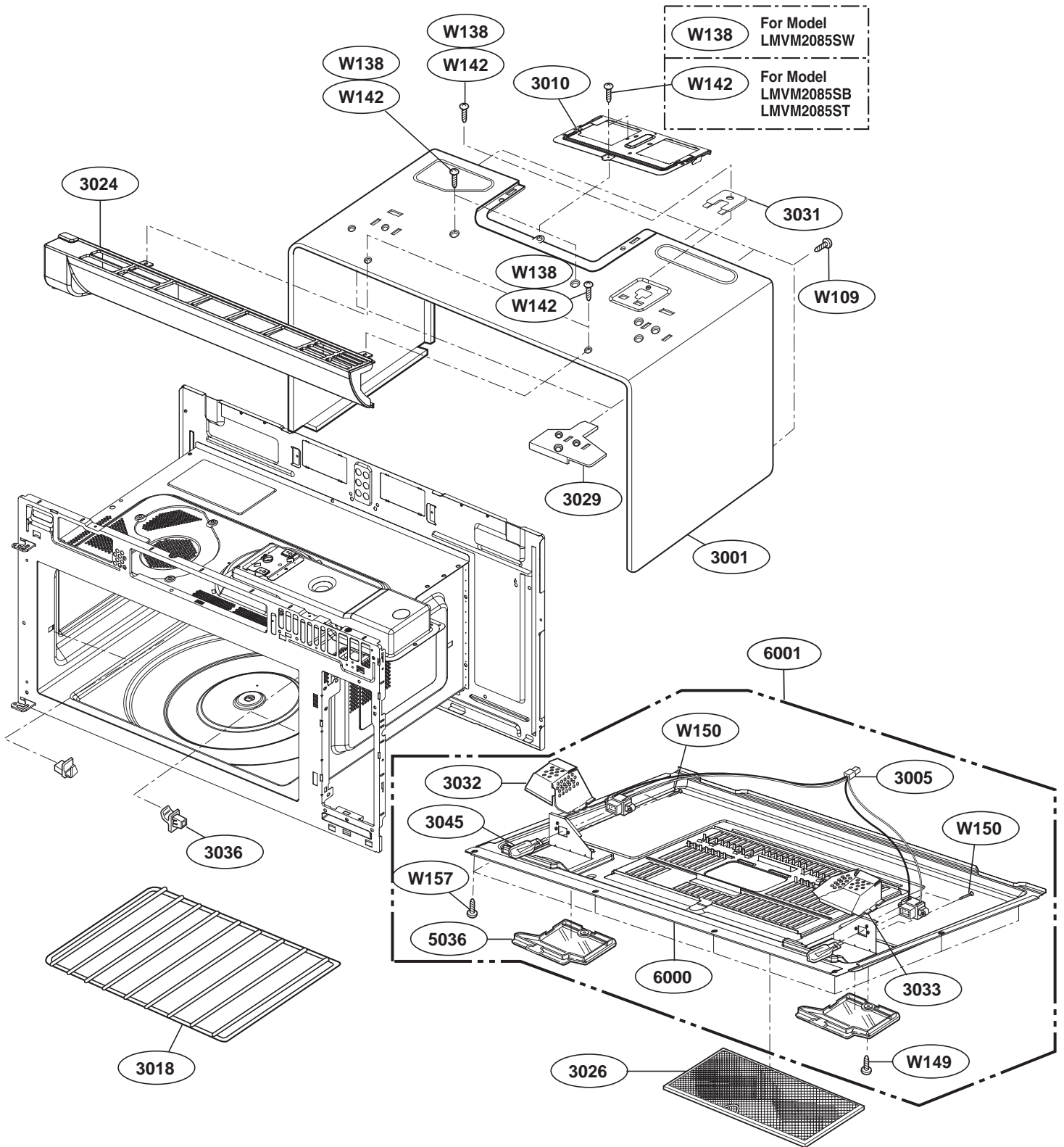

LATCH BOARD PARTS

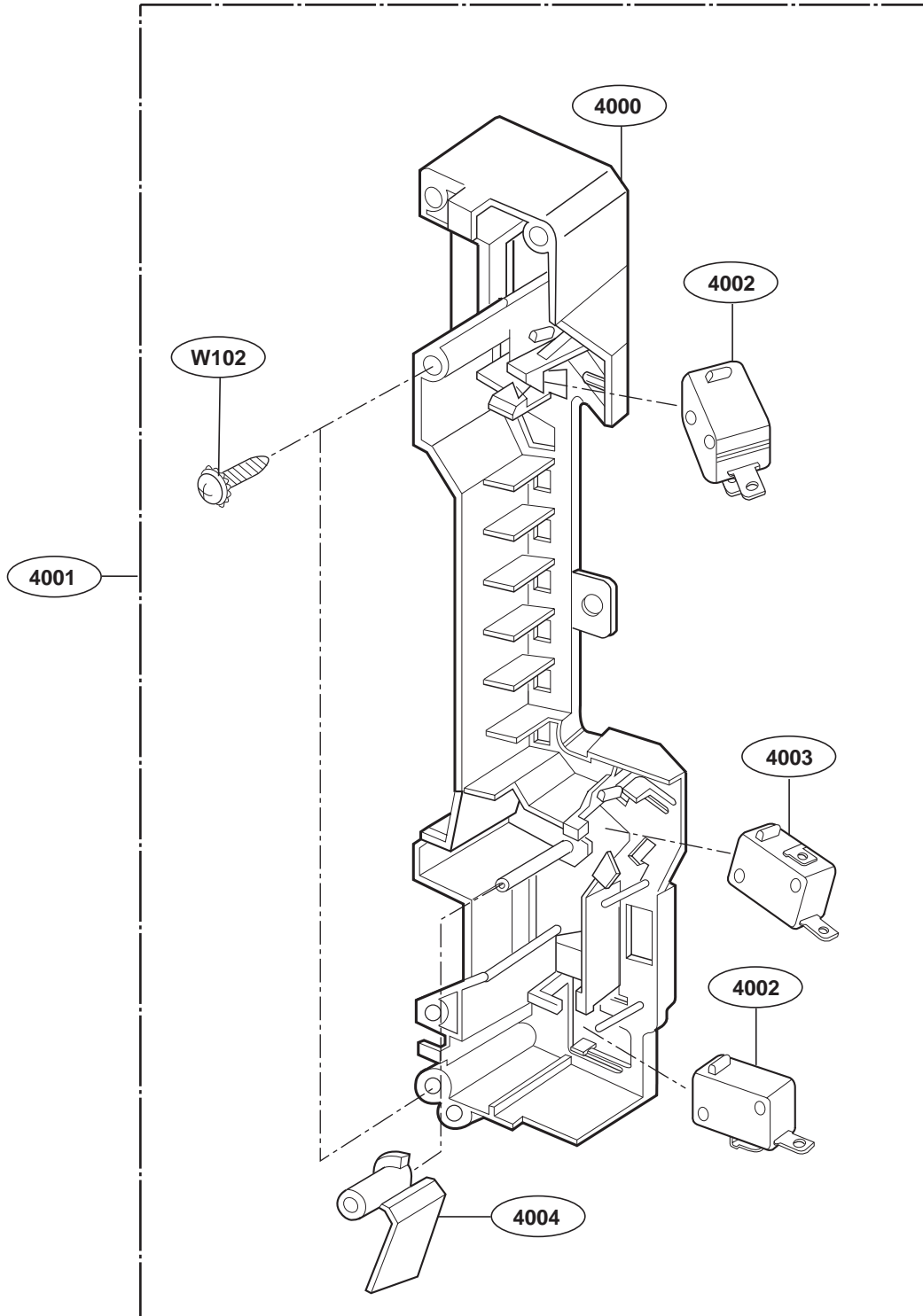

INTERIOR PARTS (I)

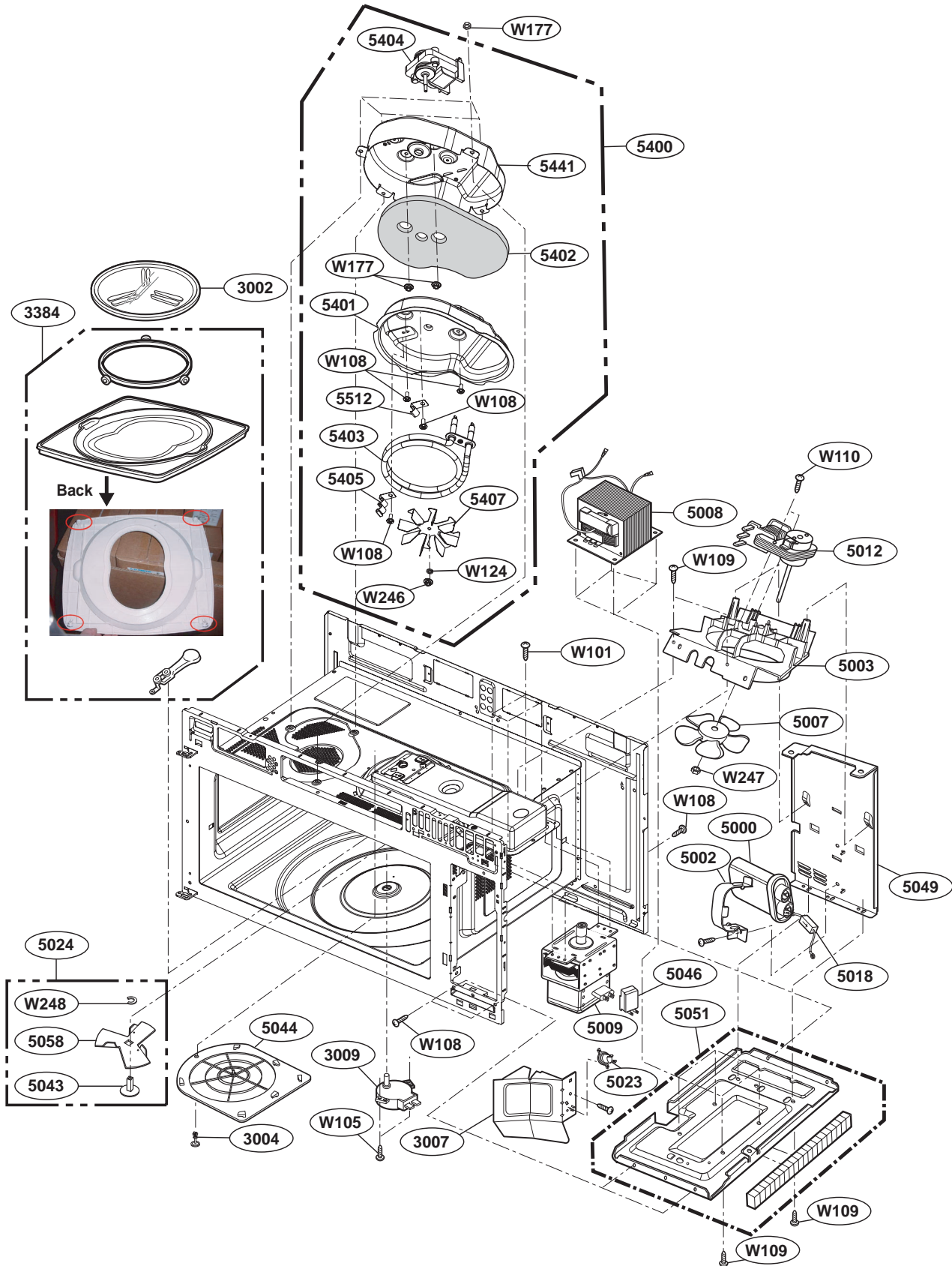

INTERIOR PARTS (II)

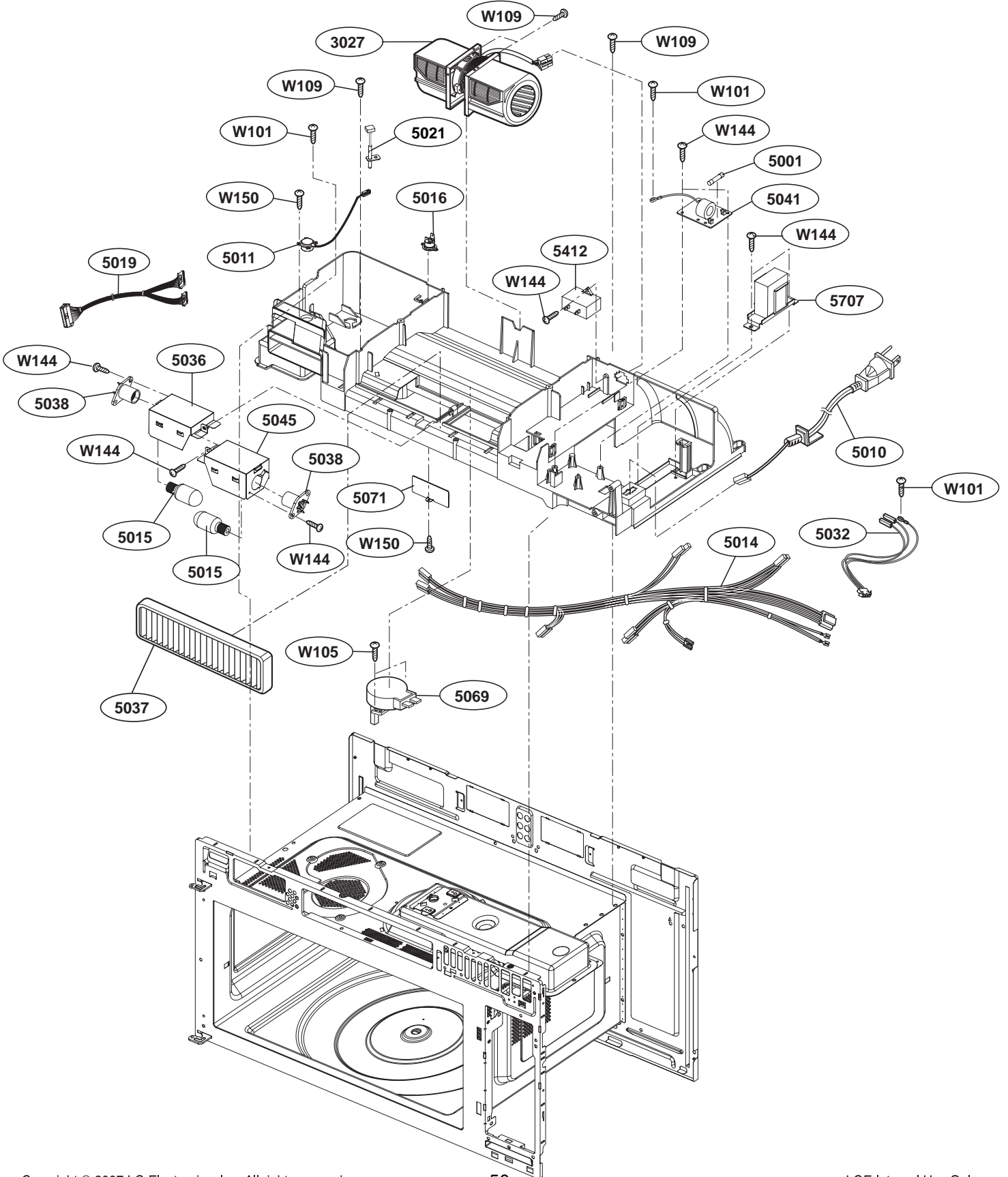

INSTALLATION PARTS

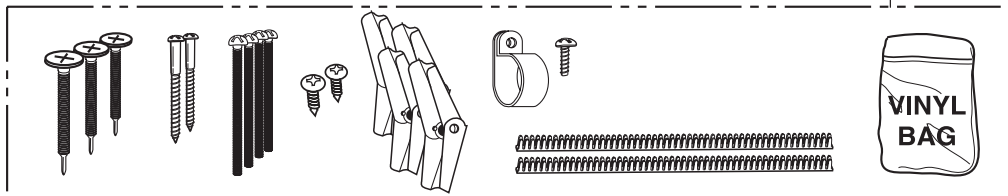
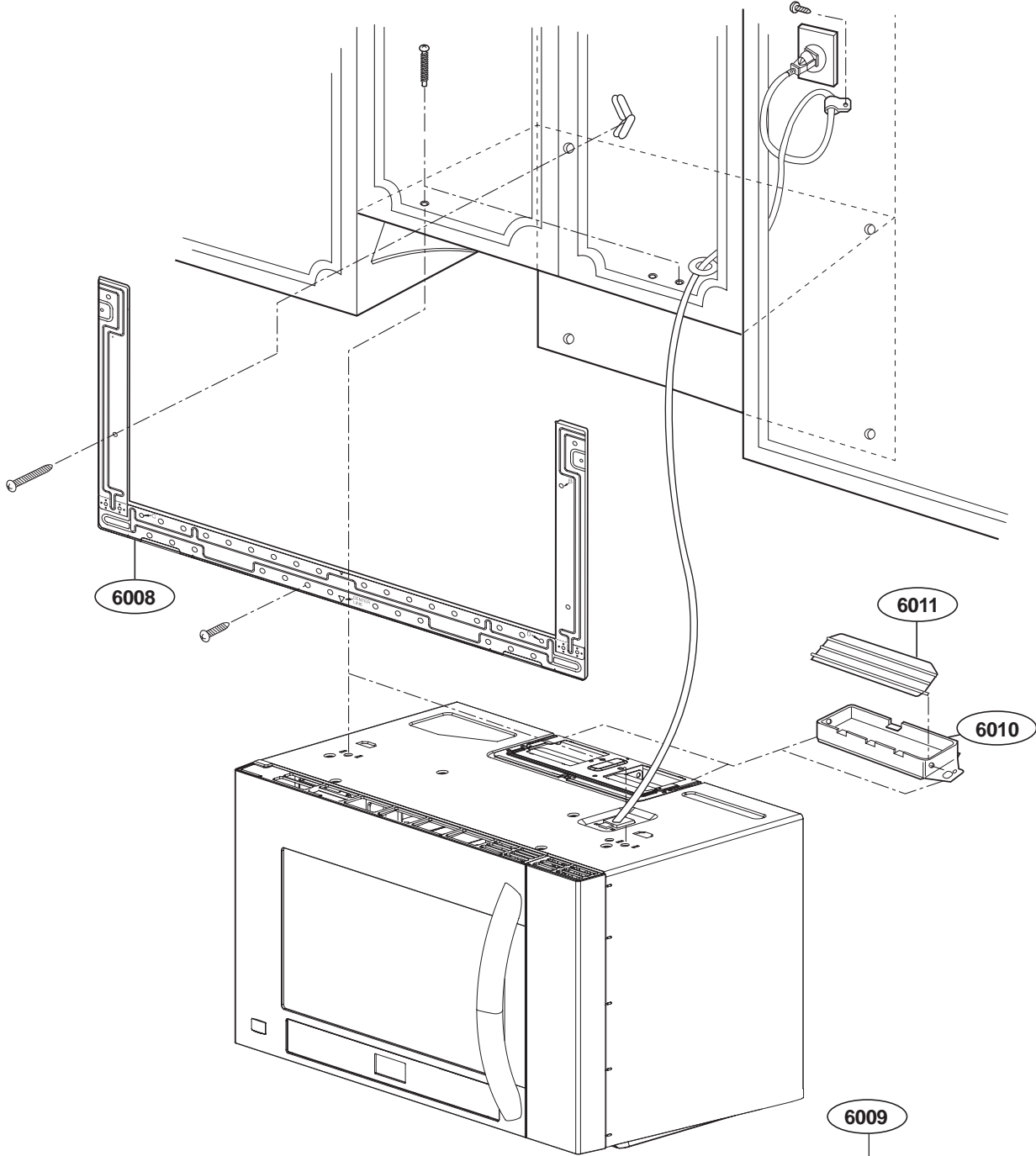

- USE & CARE (MFL1)
- INSTALLATION MANUAL (MFL3)
- COOKING GUIDE LABEL (MEZ1)
- UPPER TEMPLATE (MBM4)
- WALL TEMPLATE (MBM5)

