

This Owner's Manual is provided and hosted by [Appliance Factory Parts](#).



# LG 68274 Owner's Manual

[Shop genuine replacement parts for LG 68274](#)



\* The color vary in each model

[Find Your LG Refrigerator Parts - Select From 834 Models](#)

----- Manual continues below -----



**BOTTOM FREEZER REFRIGERATOR**

# **REFRIGERATOR SERVICE MANUAL**

**CAUTION**

**BEFORE SERVICING THE PRODUCT  
READ THE SAFETY PRECAUTIONS IN THIS MANUAL.**

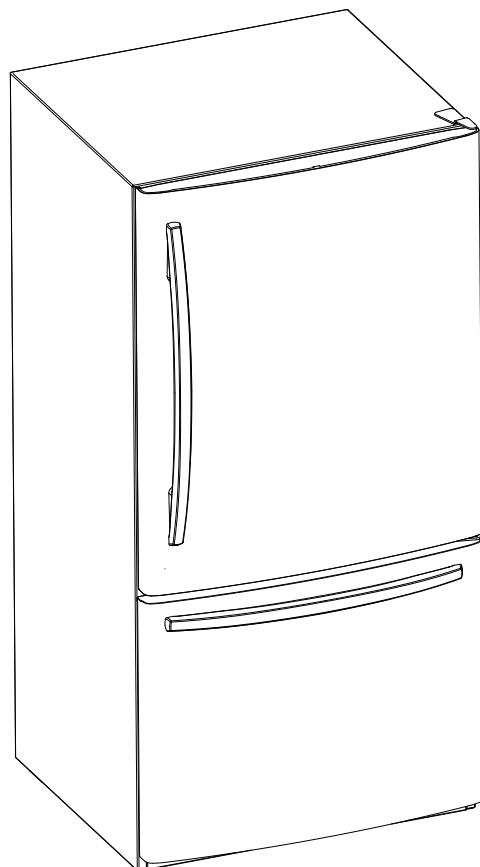

**MODELS:**

**795.7620\***

**795.6827\***

**795.7827\***

\* color number

# CONTENTS

---

<b>SAFETY PRECAUTIONS</b> .....	3
<b>1. SPECIFICATIONS</b> .....	4
<b>2. PARTS IDENTIFICATION</b> .....	6
2-1 Freezer Drawer Model.....	6
2-2 Freezer Swing Model.....	7
<b>3. DISASSEMBLY</b> .....	8
3-1 Fan and Fan Motor.....	8
3-2 Defrost Control Assembly.....	8
3-3 Lamp.....	8
3-4 Control Box Refrigerator.....	9
3-5 Multiduct.....	9
3-6 Cover Valve.....	10
3-7 Door Disassembly for Drawer Type Models.....	11
3-7-1 Remove Drawer Refrigerator Door.....	11
3-7-2 Replace Drawer Refrigerator Door.....	11
3-7-3 Reverse Drawer Refrigerator Door.....	12
3-7-4 Pull out Drawer.....	14
3-7-5 How to Reverse Drawer Door Handle.....	16
3-8 Door Disassembly for Swing Type Models.....	17
3-8-1 Remove Swing Refrigerator and Freezer Doors.....	17
3-8-2 Replace Swing Refrigerator and Freezer Doors.....	18
3-8-3 Reverse Swing Refrigerator and Freezer Doors.....	19
3-8-4 How to Reverse Swing Door Handle.....	23
3-9 After completing the job.....	24
3-10 Leveling and door closing.....	24
3-11 Door alignment.....	24
<b>4. ADJUSTMENT</b> .....	25
4-1 Compressor .....	25
4-2 PTC-Starter .....	25
4-3 OLP (overload protector) .....	26
<b>5. CIRCUIT DIAGRAM</b> .....	27
5-1 For Drawer Type Models.....	27
5-2 For Swing Type Models.....	28
<b>6. TROUBLESHOOTING</b> .....	29
6-1 Compressor and electric components .....	29
6-2 PTC and OLP .....	30
6-3 Other electrical components .....	31
6-4 Service diagnosis chart .....	32
6-5 Refrigeration cycle .....	33

---

<b>7. OPERATION PRINCIPLE AND REPAIR METHOD OF ICEMAKER .....</b>	<b>35</b>
7.1 Operation principle .....	36
7.2 Ice maker functions .....	38
<b>8. CIRCUIT OF MICOM (DRAWER TYPE MODELS).....</b>	<b>39</b>
8.1 Function .....	39
8.2 PCB function .....	43
8.3 Resistance specification of sensor .....	47
<b>9. CIRCUIT OF MICOM (SWING TYPE MODELS).....</b>	<b>48</b>
9.1 Function .....	48
9.2 PCB function .....	52
9.3 Resistance specification of sensor .....	56
<b>10. EXPLODED VIEW AND REPLACEMENT PART LIST.....</b>	<b>57</b>

---

## SAFETY PRECAUTIONS

---

Please read the following instructions before servicing your refrigerator.

- |   |   |
|---|---|
| 1. Check the refrigerator for current leakage.  | 7. Before tilting the refrigerator, remove all materials from on or in the refrigerator.  |
| 2. To prevent electric shock, unplug before servicing.                                  | 8. When servicing the evaporator, wear gloves to prevent injuries from the sharp evaporator fins.   |
| 3. Always check line voltage and amperage.  | 9. Service on the refrigerator should be performed by a qualified technician. Sealed system repair must be performed by a CFC certified technician. |
| 4. Use standard electrical components.  |   |
| 5. Don't touch metal products in the freezer with wet hands. This may cause frost bite. |   |
| 6. Prevent water from spilling on to electric elements or the machine parts.            |   |

# 1. SPECIFICATIONS

---

## 1-1. DISCONNECT POWER CORD BEFORE SERVICING

**IMPORTANT:** Reconnect all grounding devices.

All parts of this appliance capable of conducting electrical current are grounded. If grounding wires, screws, straps, clips, nuts or washers used to complete a path to ground are removed for service, they must be returned to their original position and properly fastened.

## 1-2. IMPORTANT NOTICE

This information is intended for use by individuals possessing adequate background of electrical, electronic and mechanical experience.

Any attempt to repair a major appliance may result in personal injury and property damage. The manufacturer or seller cannot be responsible for the interpretation of this information, nor can it assume any liability in connection with its use.

## 1-3. ELECTRICAL SPECIFICATIONS

Freezer temperature control (Middle setting).....	-6°F to +8°F
Defrost Control .....	Automatic
Defrost Thermostat .....	46.4°F
Electrical Rating : 115VAC, 60Hz.....	1-5 A
Maximum Current Leakage .....	0.5mA
Maximum Ground Path Resistance .....	0.14 Ohms
Energy Consumption.....	465kWh/yr (Energy Star)

## 1-4. NO LOAD PERFORMANCE

Control Position: MID/MID

And Ambient of:	70°F	90°F	
Fresh Food, °F.....	33°F to 41°F	Fresh Food, °F.....33°F to 41°F	
Frozen Food, °F.....	-4°F to +4°F	Frozen Food, °F.....-4°F to +4°F	
Percent Running Time .....	25% - 35%	Percent Running Time .....	45% - 60%

## 1-5. REFRIGERATION SYSTEM

Minimum Compressor Capacity Vacuum.....	21 in
Minimum Equalized Pressure	
@70°F.....	49 PSIG
@90°F.....	56 PSIG
Refrigerant R134a.....	4.2 oz
Compressor.....	740 BTU/hr

## 1-6. INSTALLATION

Clearance must be provided at top, sides and rear of the refrigerator for air circulation.

At Top.....	2 in
At Sides.....	2 in
At Rear.....	2 in

### 1-7. REPLACEMENT PARTS

Relay.....	EBG32606502
Overload.....	6750C-0005P
Defrost Thermostat.....	6930JK2001B
Defrost Heater.....	5300JB1100J
Evaporator Fan Motor.....	4681JB1027N
Capacitor.....	0CZZJB2012J
Compressor (Hi-Side).....	TCA32196201
Evaporator (Lo-Side).....	5421JJ1001B
Condenser.....	5403JJ1007A
Dryer.....	5851JA2007E
Condenser Fan Motor.....	4681JB1027P
Temperature Control.....	6500JB1001M
Main Control (For Drawer Type Models).....	EBR64110501
Main Control (For Swing Type Models).....	EBR64110502

PERFORMANCE DATA (NORMAL OPERATING CONDITIONS)			
AMB	WATTS	SYSTEM PRESSURE (PSIG)	
		HIGH SIDE	LOW SIDE
70°F	98 (+10 / -10)	98 (+5 / -3)	(-5) to (-2)
90°F	98 (+10 / -10)	130 (+3 / -3)	(-4) to 1
110°F	103 (+5 / -5)	174 (+5 / -5)	(-2) to 3

### 1-8. AIR FLOW

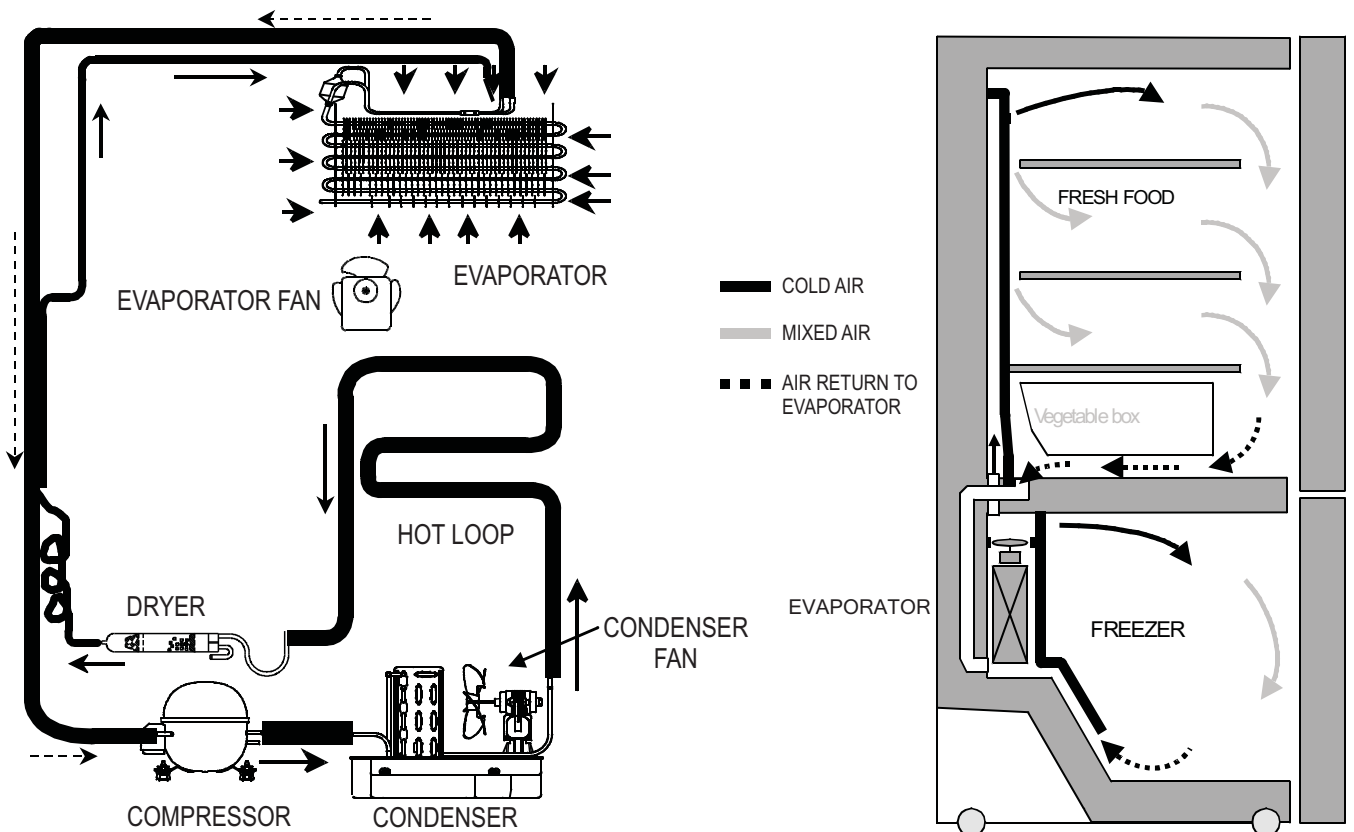

# 2. PARTS IDENTIFICATION

## 2-1 FREEZER DRAWER MODEL

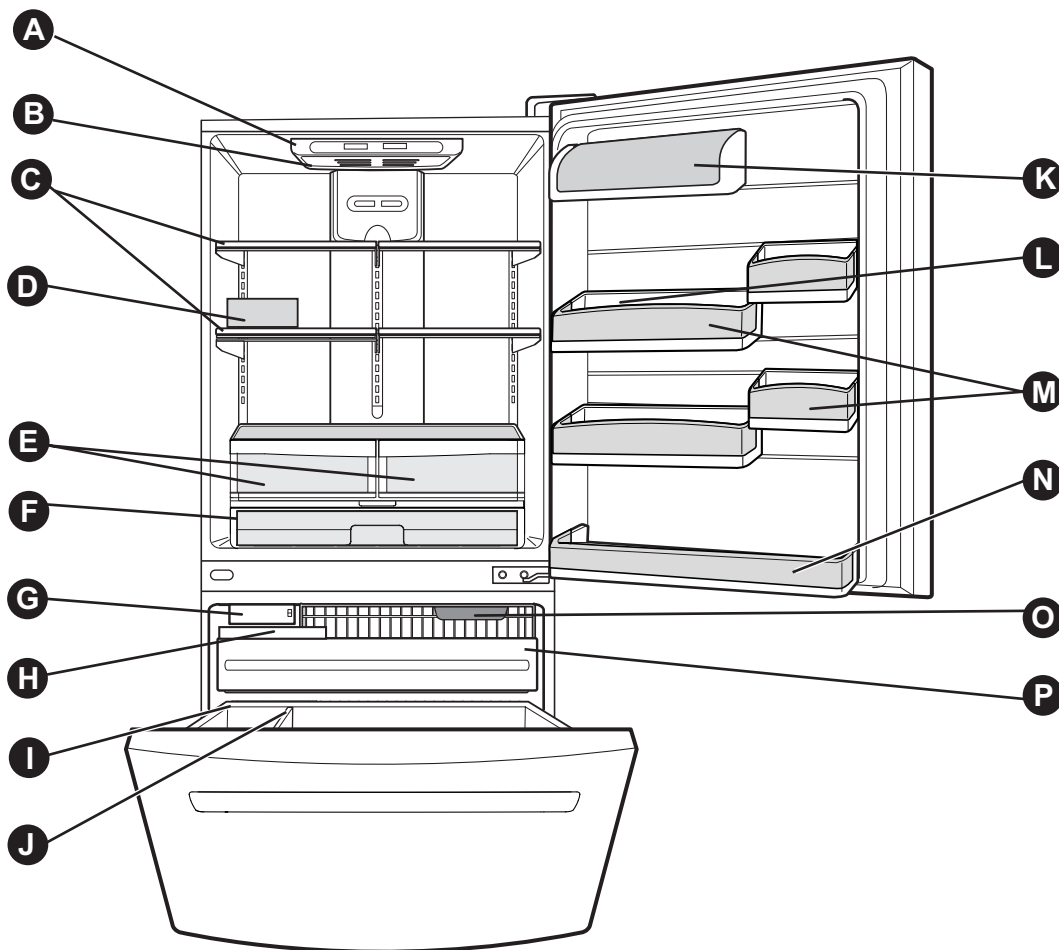

Use this section to become more familiar with the parts and features.

**NOTE: This guide covers several different models. The refrigerator you have purchased may have some or all of the items listed below. The locations of the features shown below may not match your model.**

- |   |                                 |
|---|---------------------------------|
| <b>A</b> Digital Sensor Control   | <b>I</b> Durabase               |
| <b>B</b> Refrigerator Light   | <b>J</b> Divider                |
| <b>C</b> Shelves  | <b>K</b> Dairy Bin              |
| <b>D</b> Egg Box  | <b>L</b> Bottle Guide           |
| <b>E</b> Optibin Crispers<br>Keeps fruits and vegetable fresh and crisp | <b>M</b> Door Bins              |
| <b>F</b> Pantry   | <b>N</b> Refrigerator Door Rack |
| <b>G</b> Icemaker*  | <b>O</b> Freezer Light          |
| <b>H</b> Ice Bin  | <b>P</b> Pull out Drawer        |

\*on some models

## 2-2 FREEZER SWING MODEL

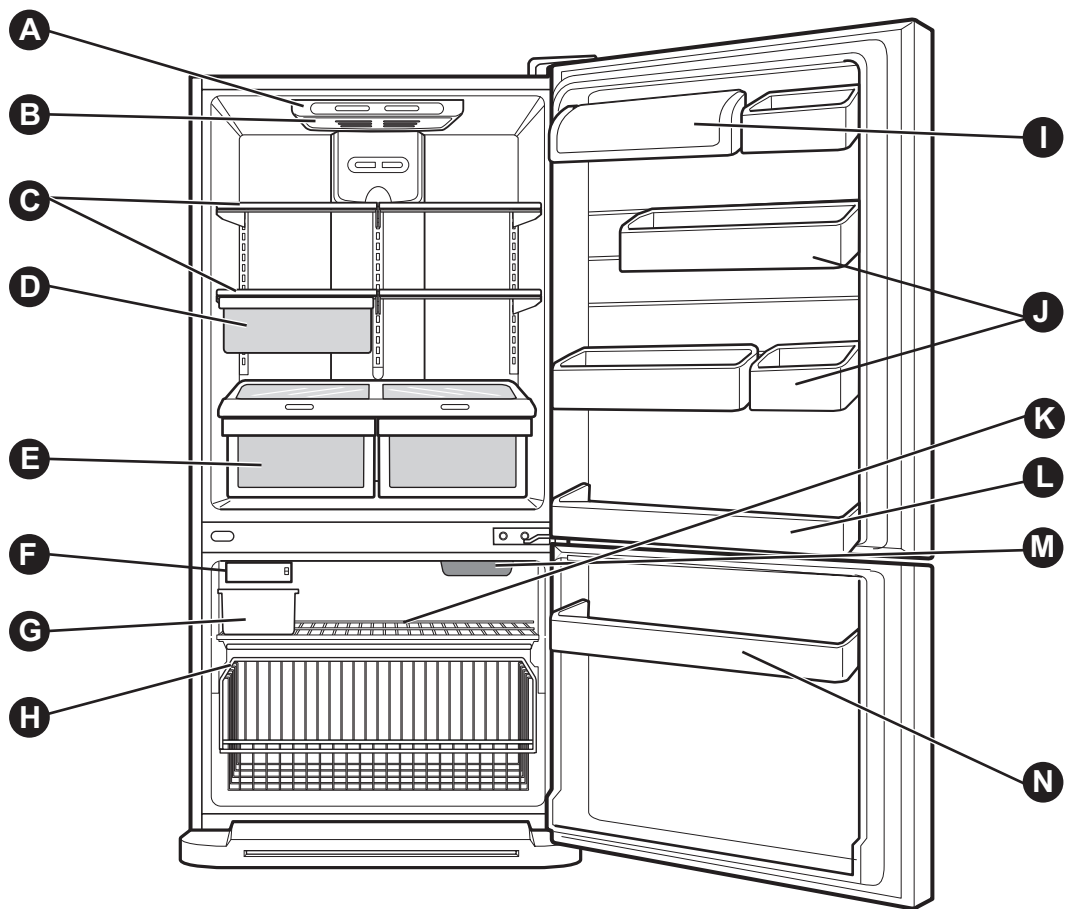

Use this section to become more familiar with the parts and features.

**NOTE: This guide covers several different models. The refrigerator you have purchased may have some or all of the items listed below. The locations of the features shown below may not match your model.**

- |  |                                 |
|--|---------------------------------|
| <b>A</b> Digital Sensor Control  | <b>I</b> Dairy Bin              |
| <b>B</b> Refrigerator Light  | <b>J</b> Door Bins              |
| <b>C</b> Shelves   | <b>K</b> Wire Freezer Shelf     |
| <b>D</b> Snack Pan   | <b>L</b> Refrigerator Door Rack |
| <b>E</b> Optibin Crisper<br>Keeps fruits and vegetable fresh and crisp | <b>M</b> Freezer Light          |
| <b>F</b> Icemaker  | <b>N</b> Freezer Door Rack      |
| <b>G</b> Ice Bin   |                                 |
| <b>H</b> Wire Durabase   |                                 |

# 3. DISASSEMBLY

## 3-1 FAN AND FAN MOTOR

1. Remove the freezer shelf. (If your refrigerator has an icemaker, remove the icemaker first).
2. Remove the plastic guide for slides on left side by unscrewing phillips head screws.
3. Remove the grille by removing one screw and pulling the grille forward.
4. Remove the Fan Motor assembly by loosening 2 screw and disassemble the shroud.
5. Pull out the fan and separate the Fan Motor and Bracket.

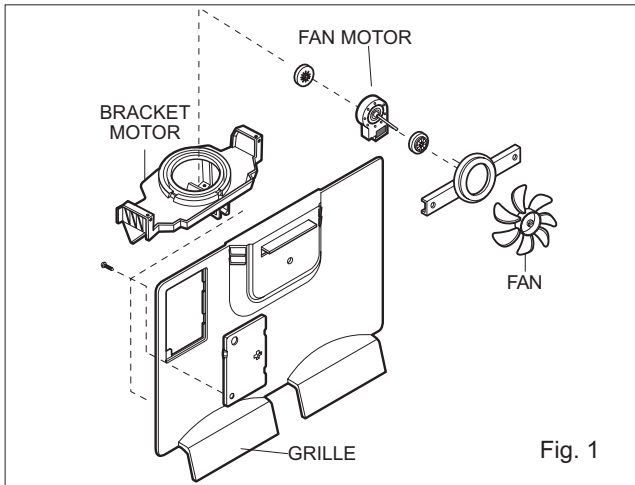

Fig. 1

## 3-2 DEFROST CONTROL ASSEMBLY

Defrost Control assembly consist of Drefrost Sensor and FUSE-M.

The Defrost Sensor works to defrost automatically. It is attached to the metal side of the Evaporator and senses its temperature.

Fuse-M is safety device for preventing over-heating of the Heater when defrosting.

At 72°C, it turns the Defrost Heater off.

1. Pull out the grille assembly. (Figure 2)
2. Separate the connector with the Defrost Control assembly and replace the Defrost Control assembly after cutting the Tie Wrap. (Figure 3)

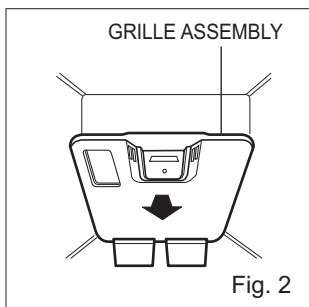

Fig. 2

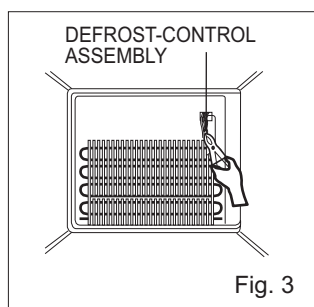

Fig. 3

## 3-3 LAMP

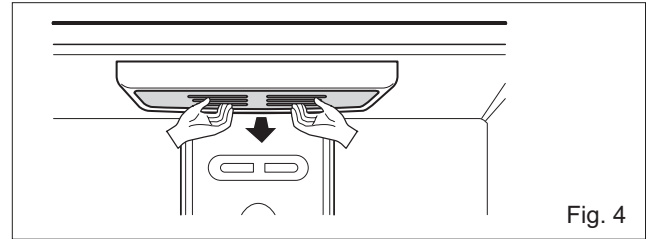

Fig. 4

### 3-3-1 REFRIGERATOR COMPARTMENT LAMP

1. Unplug the power cord from the outlet.
2. Remove Refrigerator shelves.
3. Release the hooks on both ends of the lamp shield and pull the shield downward to remove it.
4. Turn the lamp counterclockwise.
5. Assemble in reverse order of disassembly.
6. Replacement bulb must be the same specification as the original (Max. 60 W-2EA).

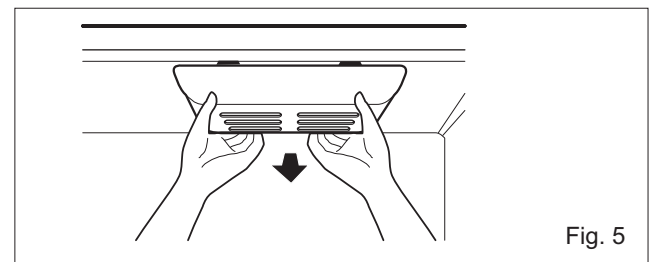

Fig. 5

### 3-3-2 FREEZER COMPARTMENT LAMP

1. Unplug refrigerator or disconnect power.
2. Reach behind light to remove bulb.
3. Replace bulb with a 60W appliance bulb.
4. Plug in refrigerator or reconnect power.

---

### 3-4 CONTROL BOX-REFRIGERATOR

1. First, remove all shelves in the refrigerator, than remove the Refrigerator control Box by loosening 2 screws.

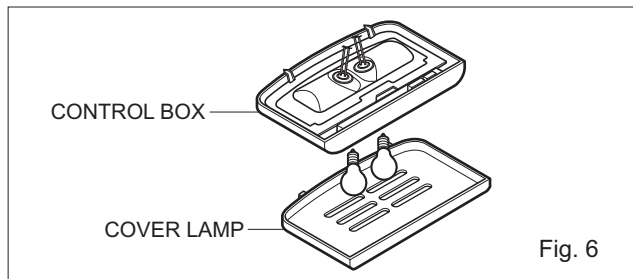

- 2. Remove the Refrigerator Control Box by pulling it downward.
- 3. Disconnect the lead wire on the right position and separate the lamp sockets.

### 3-5 MULTI DUCT

- 1. Remove an upper and lower Cap by using a flat screwdriver, and loosen 2 screws. (Figure 7,8)
- 2. Disconnect the lead wire on the botton position.

#### For Drawer Type Models

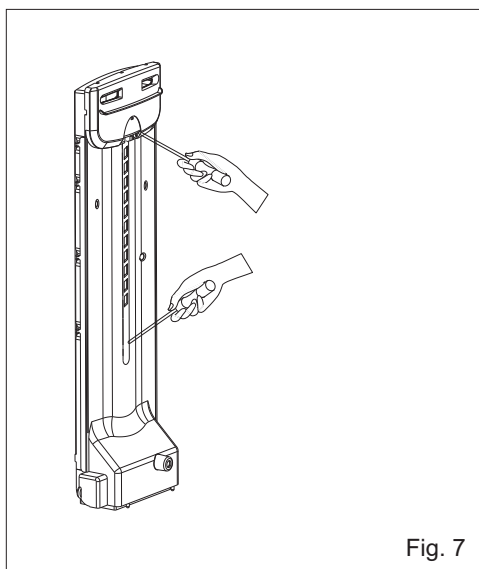

#### For Swing Type Models

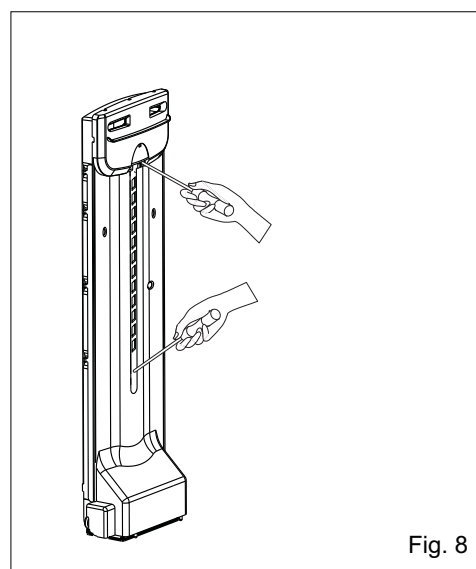

### 3-6 COVER VALVE

#### 3-6-1 DISASSEMBLE

1. Push to inside the cover valve.

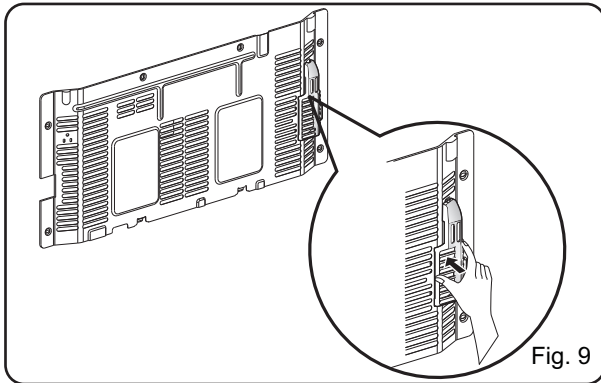

2. Push to the right and release.

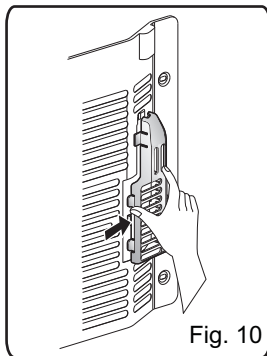

3. Release hook **a** & **b**

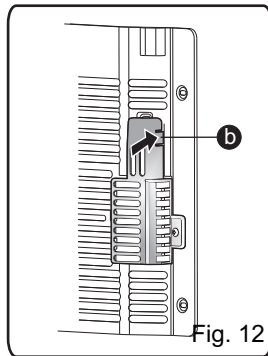
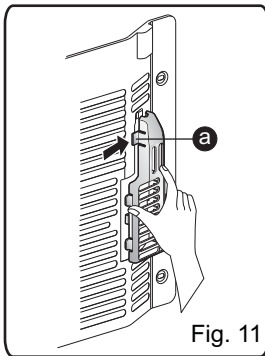

4. Turn the cover valve 120° as shown in the picture, then release it.

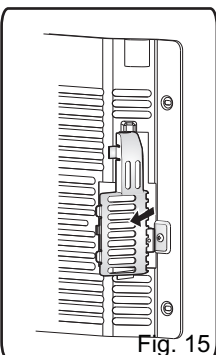
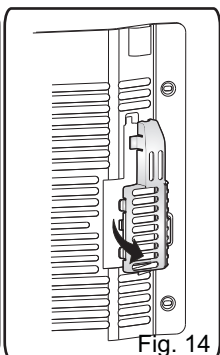
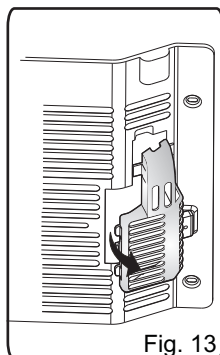

#### 3-6-2 ASSEMBLE

1. Insert the cover valve as shown in the picture, push to insert (may need force).

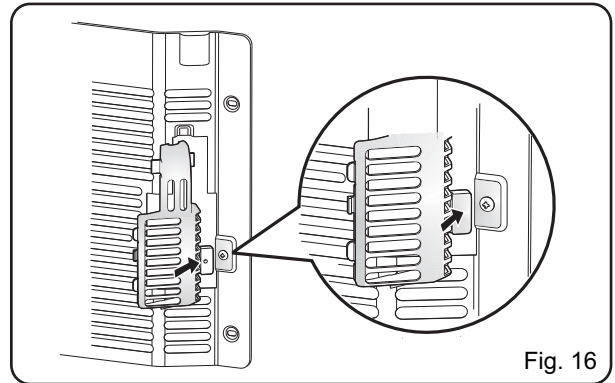

2. Insert hook **a** & **b**

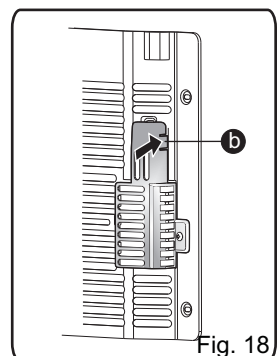
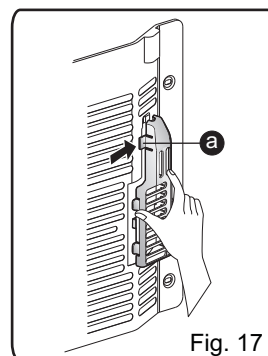

3. Push to the right to insert the cover valve.

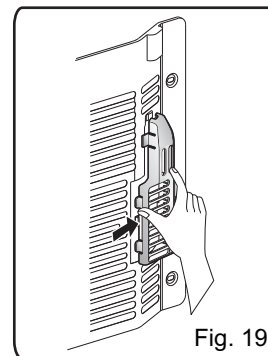

4. Then push to inside to assembly.

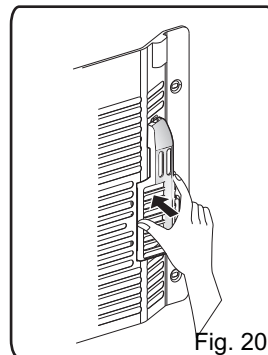

## 3-7 DOOR DISASSEMBLY FOR DRAWER TYPE MODELS

### 3-7-1 REMOVE DRAWER REFRIGERATOR DOOR

- Gently pry off Top Hinge Cover with a flat head screwdriver and remove.

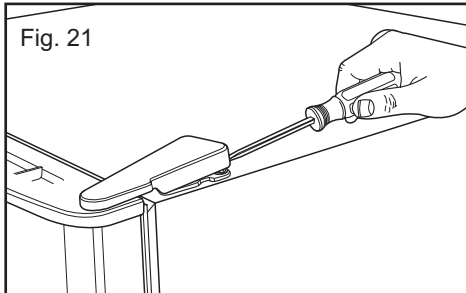

- Using 10mm or 13/32-inch socket wrench, remove the 3 bolts and lift off the Top Hinge. Set parts aside.

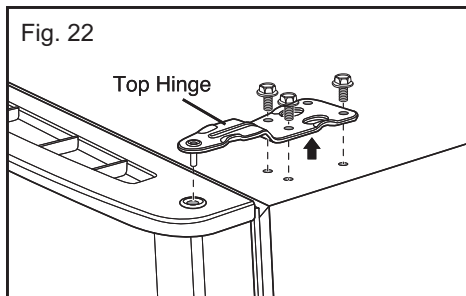

- Lift up door slightly and remove it. Place door on a non scratching surface.

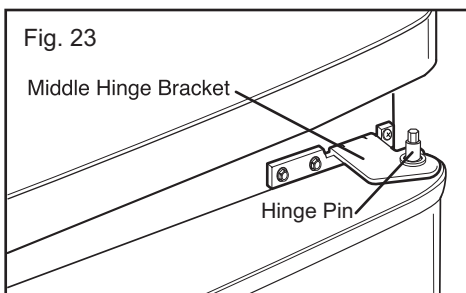

- Remove washer and set aside.
- Use a 10mm or 13/32 inch socket wrench to remove the 2 bolts in Middle Hinge Bracket. Remove screws. Set Middle Hinge Bracket and other parts aside.

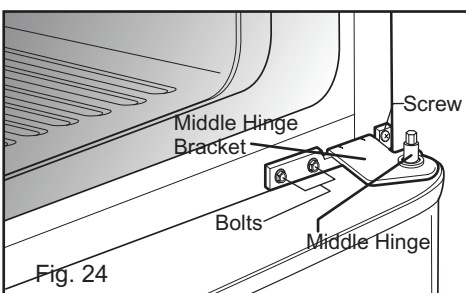

### 3-7-2 REPLACE DRAWER REFRIGERATOR DOOR

- Reattach Middle Hinge Bracket with the previously removed 2 bolts and 2 screws.

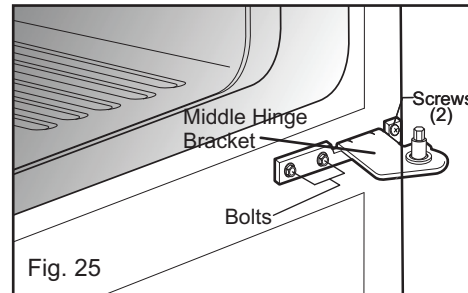

- Put refrigerator door down over the Hinge Pin on the Middle Hinge Pin Bracket.

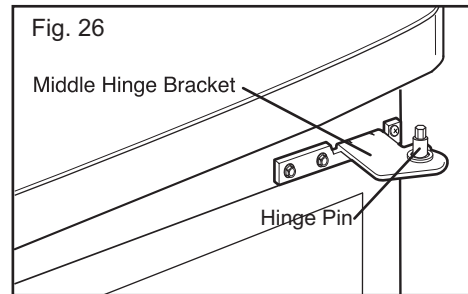

- Line up Top Hinge with holes in top of refrigerator. Use the 3 bolts to replace the Hinge.

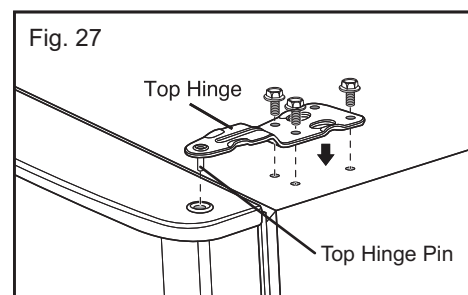

- Tighten Bolts. Force-fit Top Hinge Cover over top Hinge.

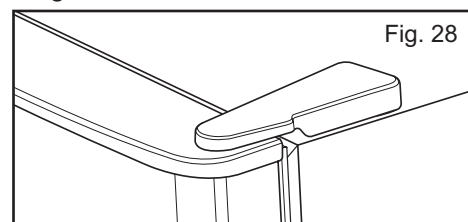

### 3-7-3 REVERSE DRAWER REFRIGERATOR DOOR

- Gently pry off Top Hinge Cover with a flat head screwdriver and remove.

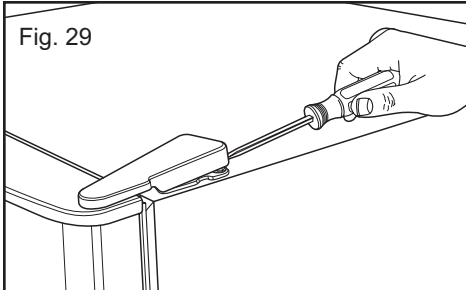

- Using 10mm or 13/32-inch socket wrench, remove the 3 bolts and lift off the Top Hinge. Set parts aside.

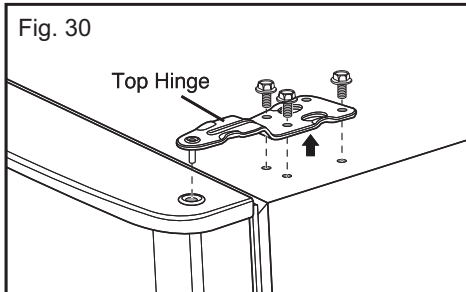

- Lift up refrigerator door slightly and remove it.

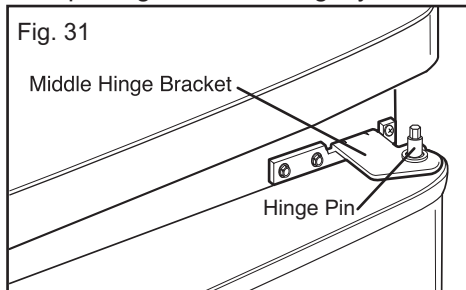

- Remove Hinge Pin Insert on the right side of the door and reinstall on left side.

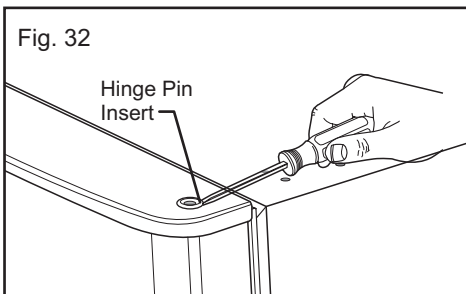

- Turn refrigerator door upside down on a non-scratch surface.
- Loosen the 2 screws to remove the Bottom Hinge Pin Insert Bracket with Hinge Pin Insert.

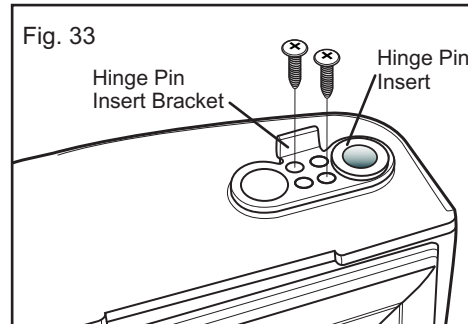

- Remove screw on the opposite side of the door. This screw is no longer necessary and can be discarded.
- Move the Hinge Pin Insert Bracket to the other side of the door, keeping the same orientation, and push the Hinge Pin Insert into the hole on the left side of the bracket. Insert the 2 screws as shown below.

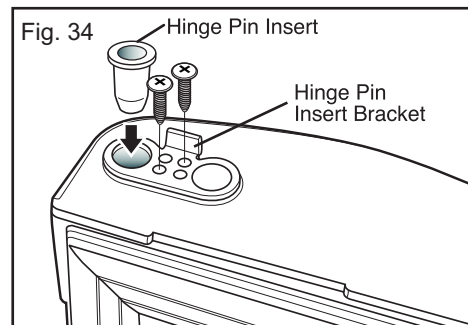

- Pry off cover on top of refrigerator on left side to uncover screw holes and place it on the right side.

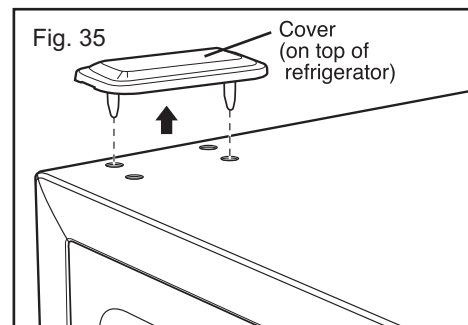

- Remove Washer and set aside.
- Using a 1/4 socket wrench, loosen and remove Hinge Pin from the Middle Hinge Bracket.

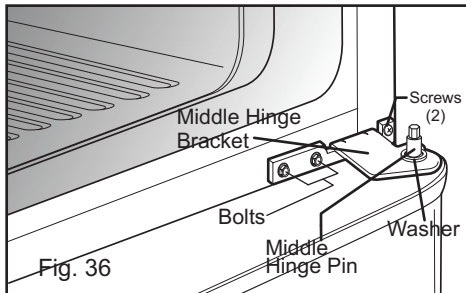

- Flip the middle hinge bracket and position on left side of refrigerator and re-attach with two bolts and a 2 phillips screws.

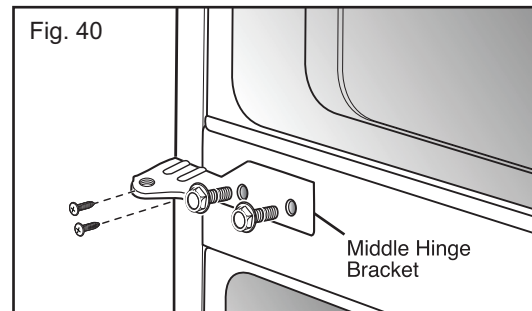

- Use a 10mm or 13/32 inch socket wrench to remove the 2 bolts in Middle Hinge Bracket. Remove 2 screws. Set Middle Hinge Bracket and other parts aside.
- With a flat-head screwdriver, carefully pry off and remove the cover over the screw holes on the left side of refrigerator housing.

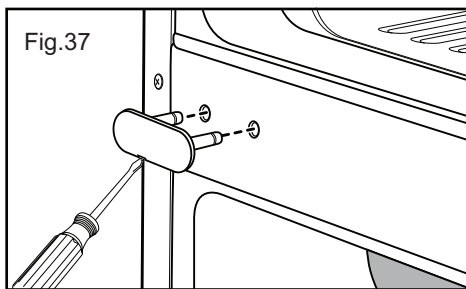

- Attach Middle Hinge Pin and replace washer.
- Put refrigerator door down over the Hinge Pin on the Middle Hinge Pin Bracket.

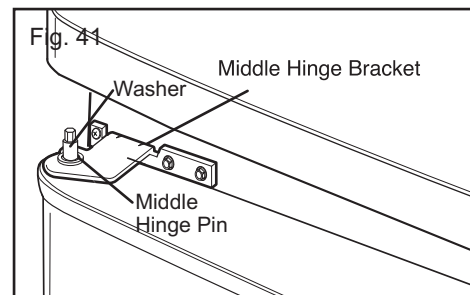

- Remove the 2 outer screws from cabinet frame as shown. You will need these holes for the Middle Hinge Bracket.

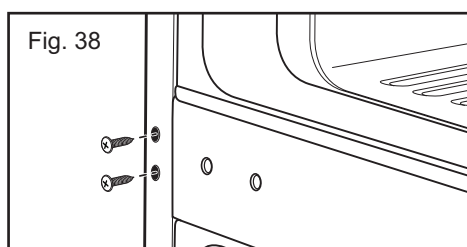

- Line up Top Hinge with holes in top of refrigerator. Use the 3 bolts to replace the Hinge.

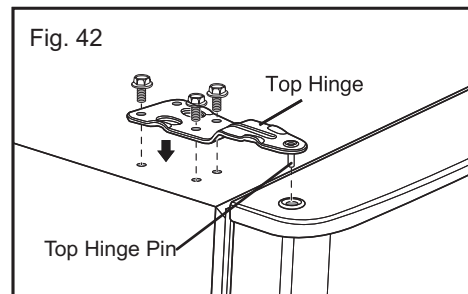

- Place screws into outer holes on right side of cabinet. Attach cover on the right side. Cover is force-fitted.

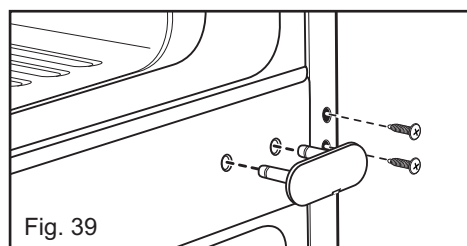

- Tighten Bolts. Force-fit Top Hinge Cover over top Hinge.

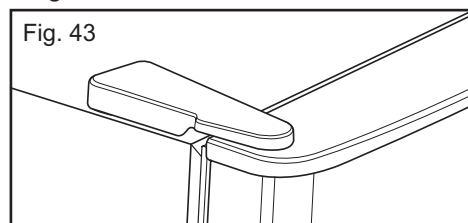

### 3-7-4 PULL OUT DRAWER

#### (a) HOW TO REMOVE PULL OUT DRAWER

**IMPORTANT:** To avoid possible injury, product or property damage, you will need two people to perform the following instructions.

- Pull the drawer open to full lower extension. Remove durabase by lifting it from rail system.

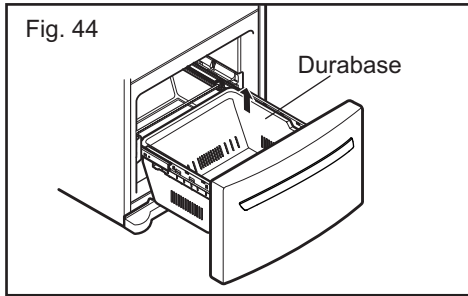

- Press both hangers with your thumbs to lift it up.

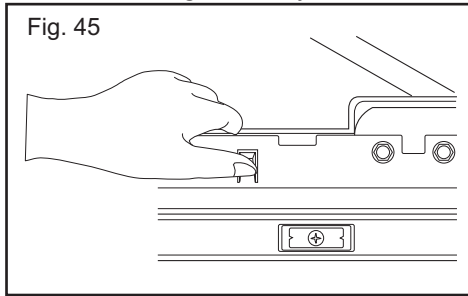

- Separate the left and right rail cover

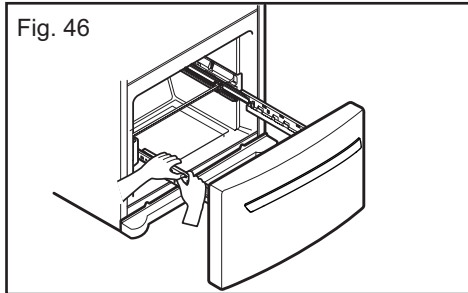

- Remove the screws of the rail on both sides.

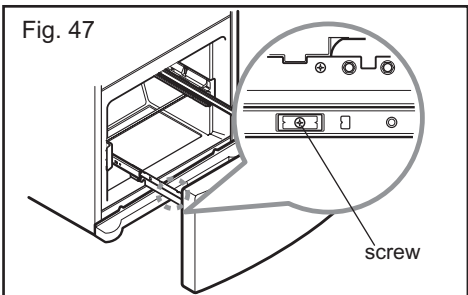

**CAUTION:** When removing drawer door, do not hold it by the handle. Door could fall down and you may be injured grasp door with both hands as pictured below When removing.

**CAUTION:** When laying down the drawer, be careful not to damage the floor or hurt your feet with the sharp edges on hinge side.

- With both hands, hold both sides of the door and pull it up to separate it from the rails.

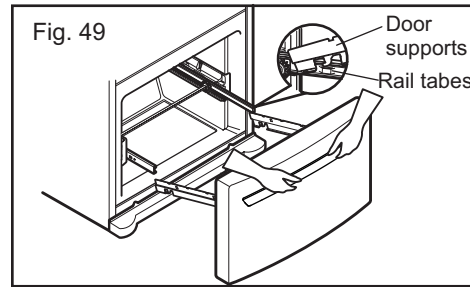
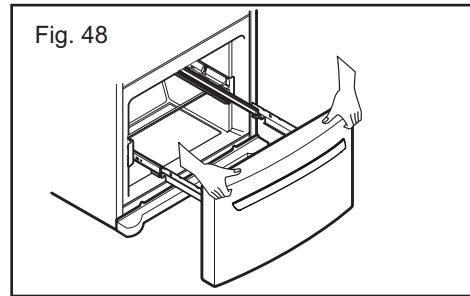

- Push rails back into drawer cavity. With both hands, hold the center of the bar and push it in so that both rails go back simultaneously.

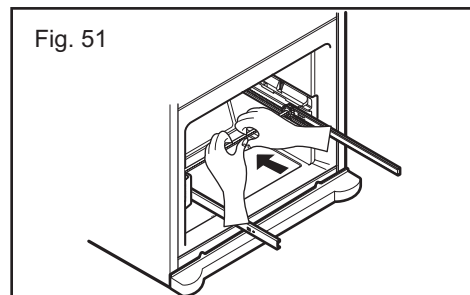
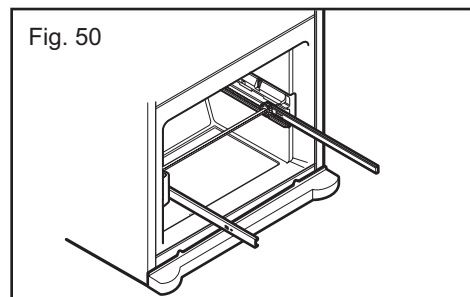

## (b) HOW TO INSTALL PULL OUT DRAWER

**IMPORTANT:** To avoid possible injury, product or property damage, you will need two people to perform the following instructions.

- With both hands, hold the center of the bar and pull it out to let both rails out to full extension simultaneously.

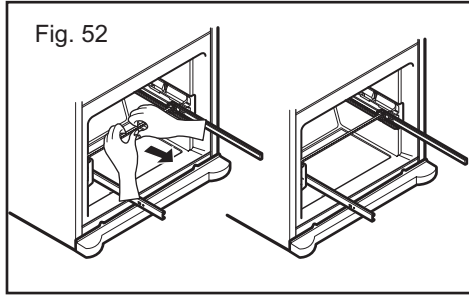

- Hook door supports into rail tabs.

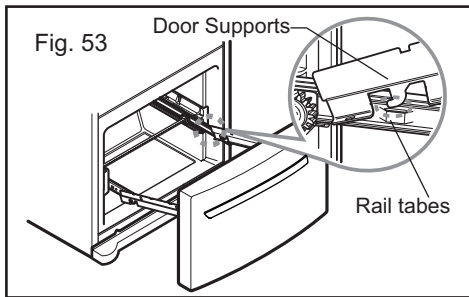

- Lower door into final position and tighten the screws.

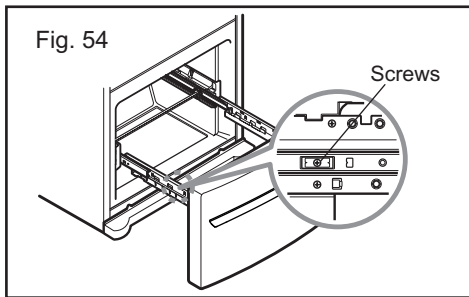

- Make sure you have a right rail cover for each side.

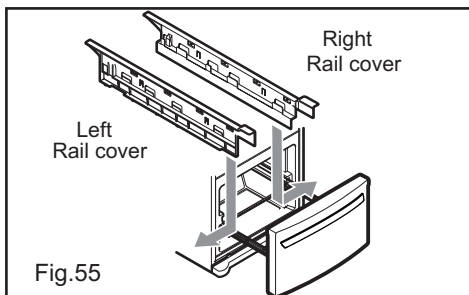

- Align the top holes of the rail cover with the top holes of the door supports to assemble the rail cover.

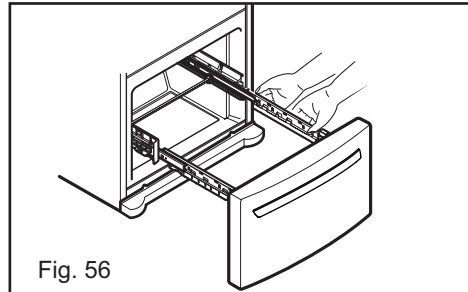

- Verify the hole's assembly

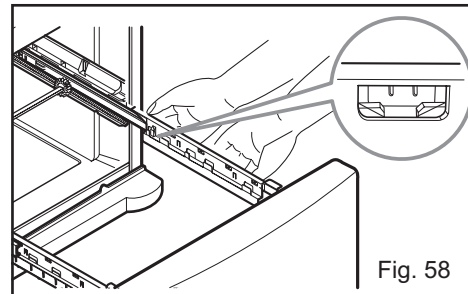
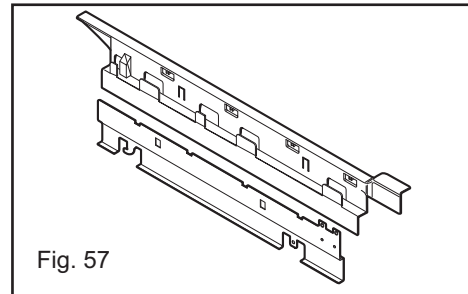

- With the rails pulled out to full extension, insert the durabase in the rail assembly.

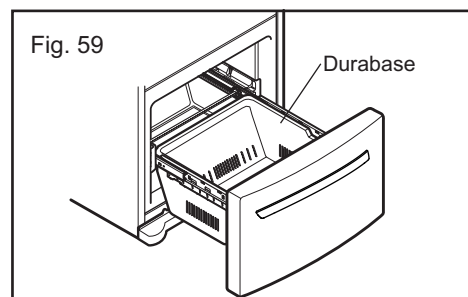

**⚠ WARNING:** To prevent accidental child and pet entrapment or suffocation risk. DO NOT allow them to play inside of drawer.

**⚠ WARNING:** DO NOT step or sit down on Freezer Door.

### 3-7-5 HOW TO REVERSE DRAWER DOOR HANDLE

**NOTE:** Handle appearance may vary from illustrations on this page.

- Loosen the 2 set screws with the 3/32" Allen wrench and remove the handle.

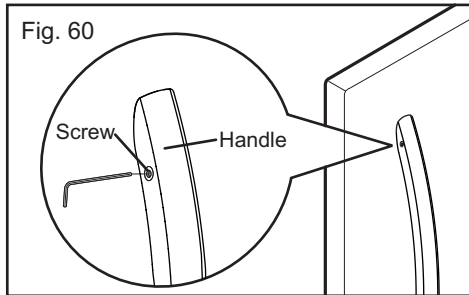

- Loosen the handle mounting fasteners with the 1/4" Allen wrench.

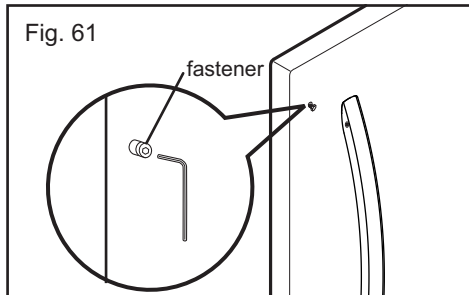

- Unscrew the buttons with your fingers by rotating counterclockwise; they will loosen and fall free.

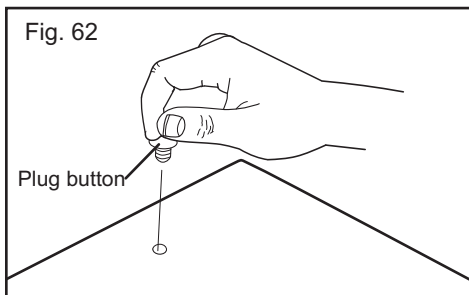

- Install the plug buttons on the left side.

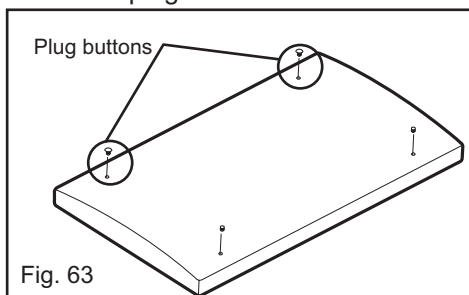

- Install the handle mounting fasteners on the right side. Turn handle upside down.

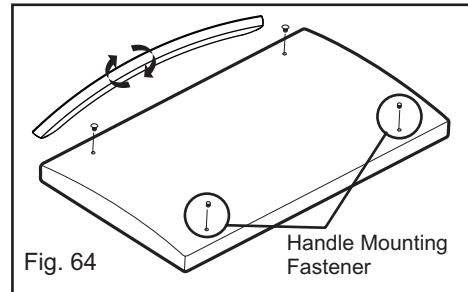

- Install the handle by adjusting handle footprints to fit mounting fasteners. Using a 3/32" allen wrench tighten the set screws.

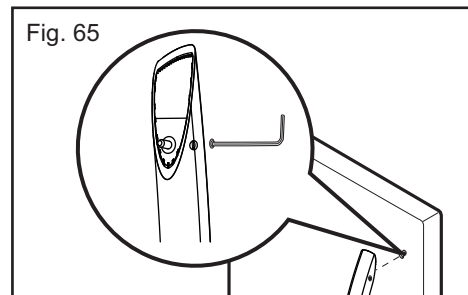

## 3-8 DOOR DISASSEMBLY FOR SWING TYPE MODELS

### 3-8-1 REMOVE SWING REFRIGERATOR AND FREEZER DOORS

Before removing the doors, remove the Base Grille.

- Gently pry off the Top Hinge Cover with a flat head screwdriver and remove.

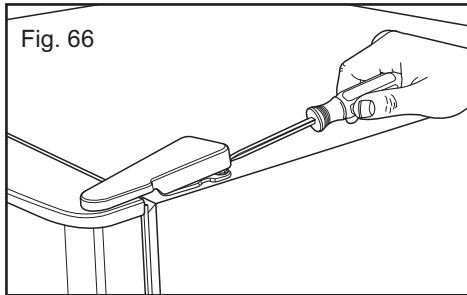

- Using 10mm or 13/32-inch socket wrench, remove the 3 bolts and lift off the Top Hinge. Set parts aside.

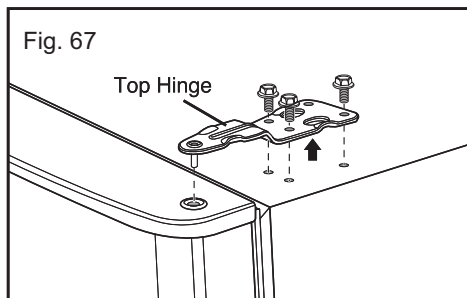

- Lift up door slightly and remove it. Place door on a non scratching surface.

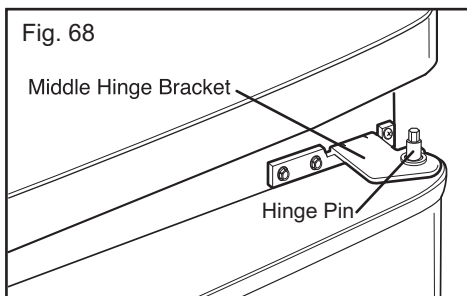

- Remove washer and set aside.

Using a 1/4 socket wrench, loosen and remove Hinge Pin from the Middle Hinge Bracket.

- Use a 10mm or 13/32 inch socket wrench to remove the 2 bolts in Middle Hinge Bracket. Remove screws. Set Middle Hinge Bracket and other parts aside.

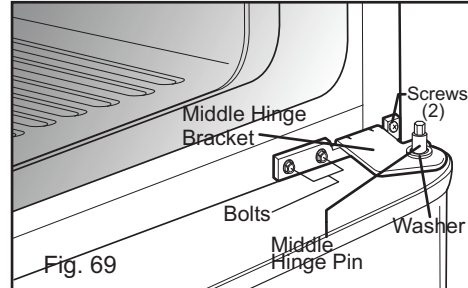

- Carefully lift up the freezer door. Remove and place it on a non-scratching surface.

- Using a 13/32" 10mm socket wrench with a 2" extension, loosen the 2 bolts and remove Bottom Hinge Bracket from right side.

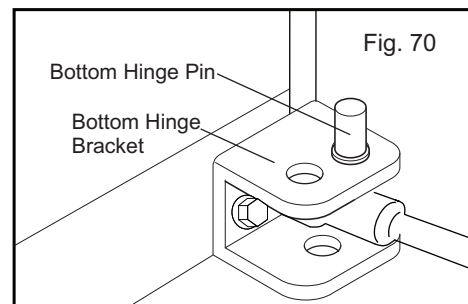

### 3-8-2 REPLACE SWING REFRIGERATOR AND FREEZER DOORS

- Reattach Bottom Hinge Bracket using the 2 previously removed bolts.
- Reattach Middle Hinge Bracket with the previously removed 2 bolts and 2 screws.

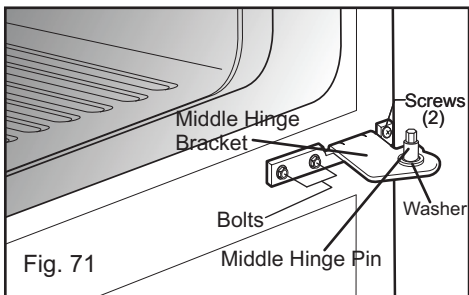

- Place freezer door down on Bottom Hinge Pin.

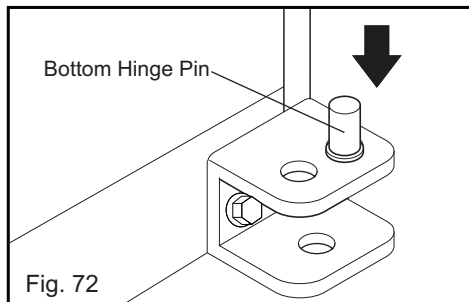

Reattach Middle Hinge Pin. Replace washer.

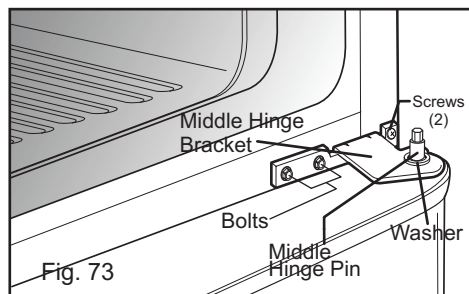

- Put refrigerator door down over the Hinge Pin on the Middle Hinge Pin Bracket.

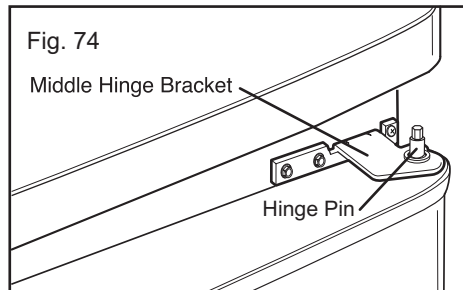

- Line up Top Hinge with holes in top of refrigerator. Use the 3 bolts to replace the Hinge.

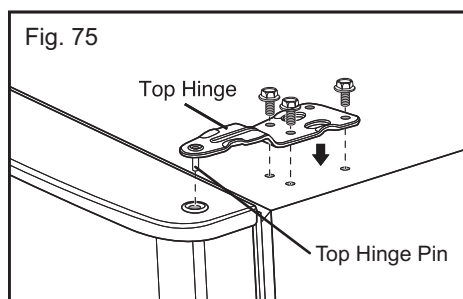

- Tighten Bolts. Force-fit Top Hinge Cover over top Hinge.

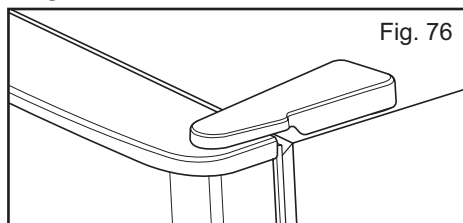

### 3-8-3 REVERSE SWING REFRIGERATOR AND FREEZER DOORS

- Gently pry off the Top Hinge Cover with a flat head screwdriver and remove.

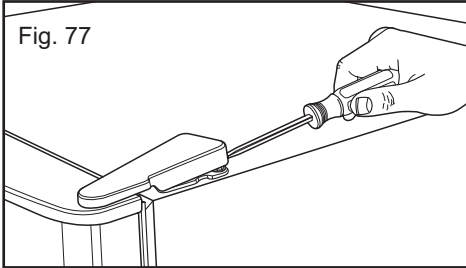

- Using 10mm or 13/32-inch socket wrench, remove the 3 bolts and lift off the Top Hinge. Set parts aside.

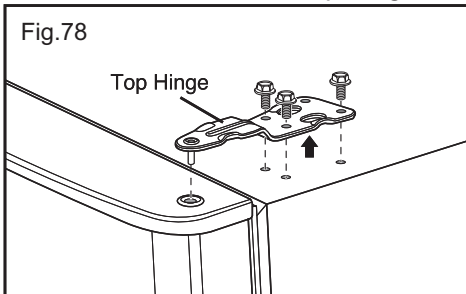

- Lift up refrigerator door slightly and remove it.

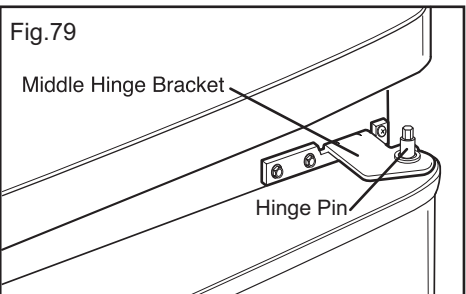

- Remove Hinge Pin Insert on the right side of the door and reinstall on left side of door.

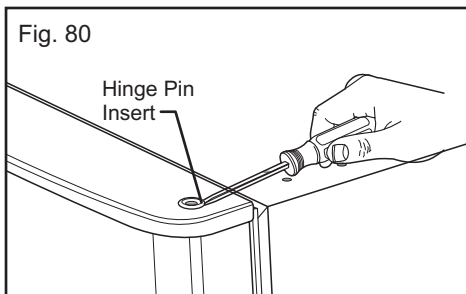

- Turn refrigerator door upside down on a non-scratch surface.

- Loosen the 2 screws to remove the Bottom Hinge Pin Insert Bracket with Hinge Pin Insert.

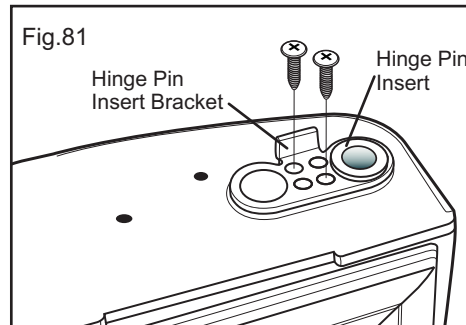

- Remove the screw on the opposite side of the door. This screw is no longer necessary and can be discarded.

- Move the Hinge Pin Insert Bracket to the other side of the door, keeping the same orientation, and push the Hinge Pin Insert into the hole on the left side of the bracket. Insert the 2 screws as shown below.

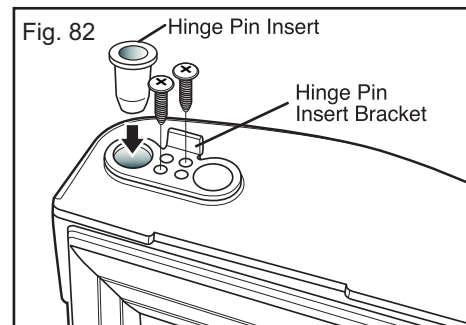

- Pry off cover on top of refrigerator on left side to uncover screw holes and place it on the right side.

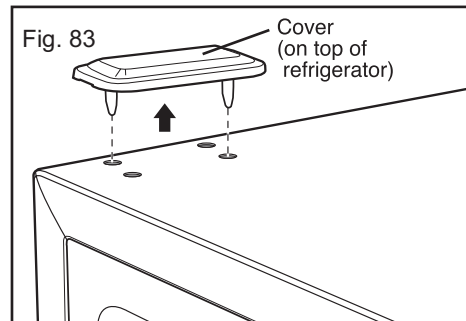

- Remove Washer and set aside.
- Using a 1/4 socket wrench, loosen and remove Hinge Pin from the Middle Hinge Bracket.

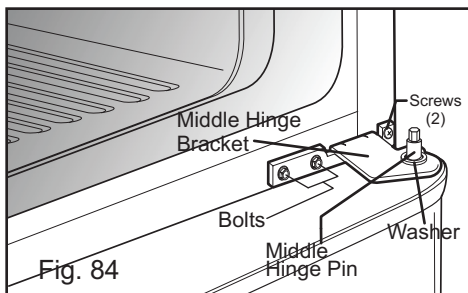

- Carefully lift up the freezer door. Remove and place it on a non scratching surface.
- Turn freezer door upside down.

- With door upside down, loosen the 2 screws and remove the Door Closer/Stop.

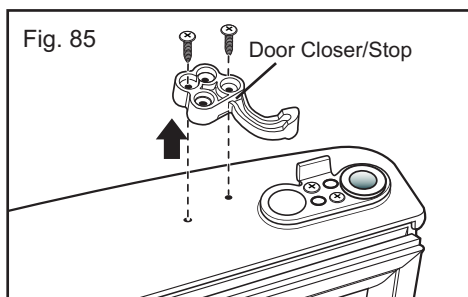

- Remove the screw on the opposite side of the door. This screw is no longer necessary and can be discarded.
- Move the Hinge Pin Insert Bracket to the other side of the door, keeping the same orientation, and push the Hinge Pin Insert into the hole on the left side of the bracket. Insert the 2 screws as shown below.

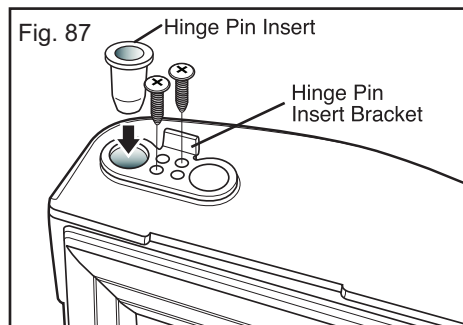

- Take Door Closer/Stop and flip. Line up screw holes and mount on left side of door bottom with the 2 screws. Turn door upright and set aside.

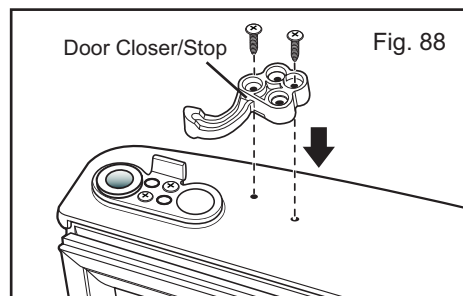

Loosen the 2 screws to remove the Bottom Hinge Pin Insert Bracket with Hinge Pin Insert.

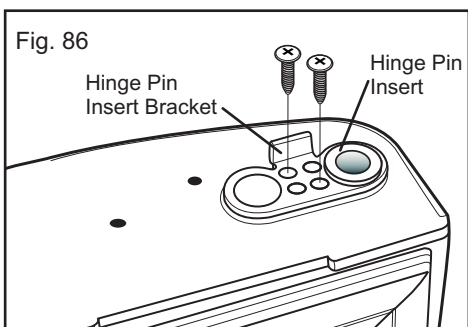

- Use a 10mm or 13/32 inch socket wrench to remove the 2 bolts in Middle Hinge Bracket. Remove 2 screws. Set Middle Hinge Bracket and other parts aside.

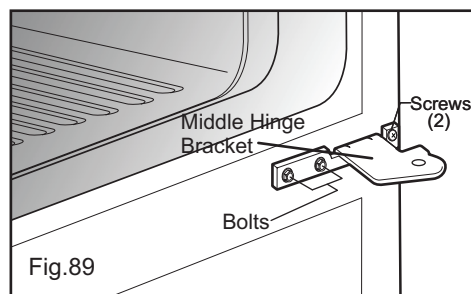

- With a flat-head screwdriver, carefully pry off and remove the cover over the screw holes on the left side of refrigerator housing.

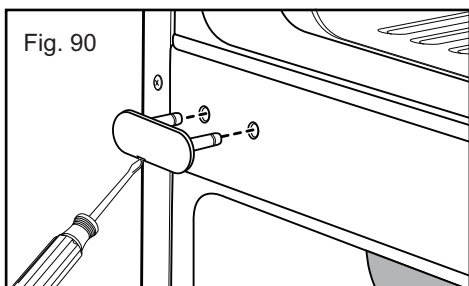

- Remove the 2 outer screws from cabinet frame as shown. You will need these holes for the Middle Hinge Bracket.

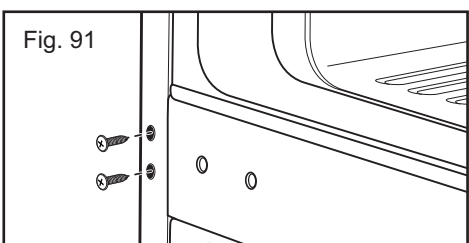

- Place screws into outer holes on right side of cabinet. Attach cover on the right side. Cover is force-fitted.

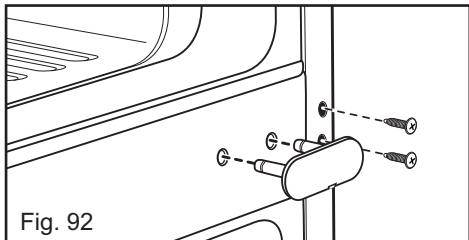

- Flip the middle hinge bracket and position on left side of refrigerator and re-attach with two bolts and a 2 phillips screws.

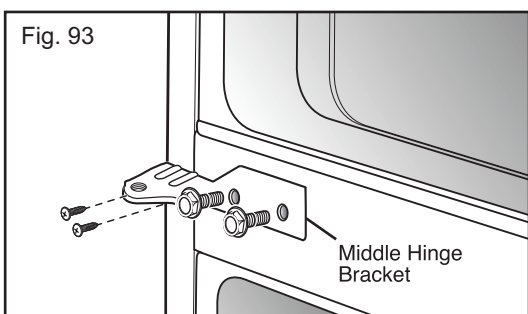

- Using a 13/32" or 10mm socket wrench with 2" extension, loosen the 2 bolts and remove bottom hinge from right side.

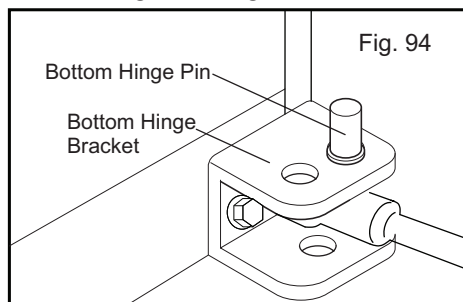

- Remove the bolt on bottom of refrigerator from the left side and insert it on the right side. You will need this hole for the Bottom Hinge.

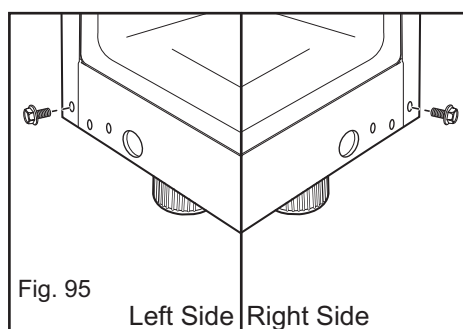

- Move the Bottom Hinge to the left side keeping the same orientation and attach 2 bolts.

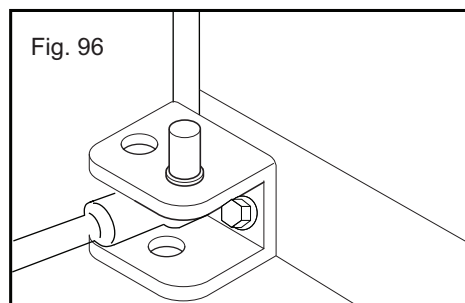

- Change the Hinge Pin from the right side to left side.

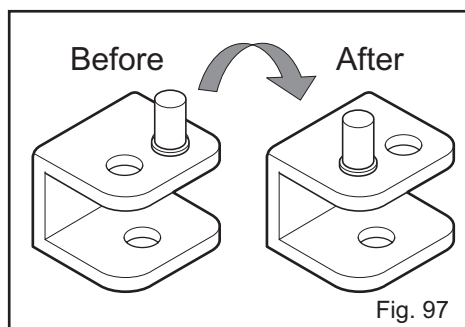

- 
- Put freezer door down over the Bottom Hinge Pin on the Bottom Hinge Bracket.
  - Reattach Middle Hinge Pin using a 1/4" socket wrench. Replace washer.
  - Put refrigerator door down over the Hinge Pin on the Middle Hinge Pin Bracket.

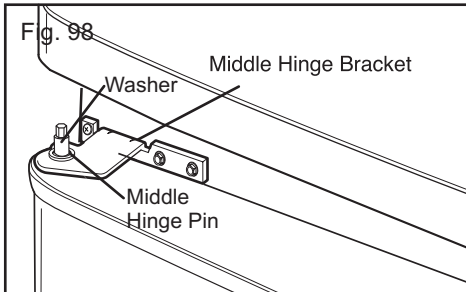

- Line up Top Hinge with holes in top of refrigerator. Use the 3 bolts to replace the Hinge.

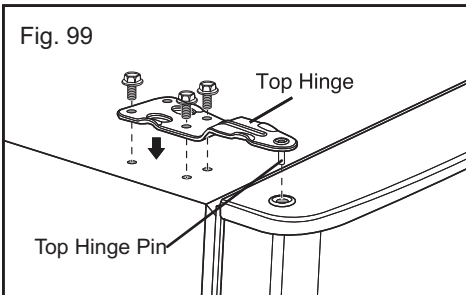

- Tighten Bolts. Force-fit Top Hinge Cover over top Hinge.

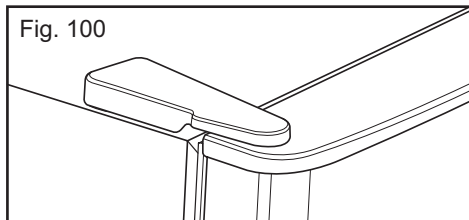

### 3-8-4 HOW TO REVERSE SWING DOOR HANDLE

**NOTE:** To assist in installing the handle on the right side, place a small piece of masking tape near the top of the handle before removing.

- Grasp the handle tightly with both hands and slide the handle up (this may require some force).
- The keyhole slots on the back of the handle allow the handle to separate from the mounting screws.

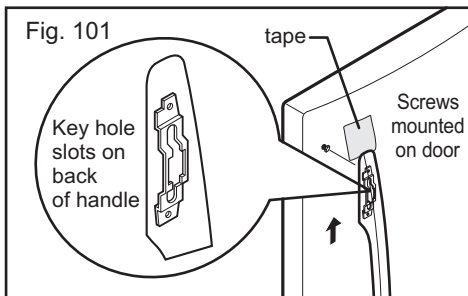

- Use an adjustable wrench to remove the 2 handle mounting screws.

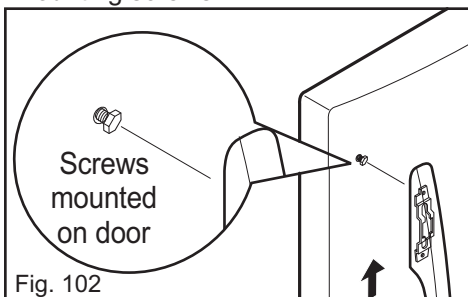

**⚠ CAUTION**  
To avoid scratching the door. Do not remove the plug buttons by prying with a screwdriver.

- Unscrew the buttons with your fingers by rotating counterclockwise; they will loosen and fall free.

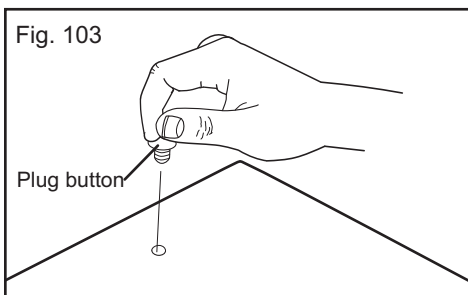

- Install the plug buttons on the left side.

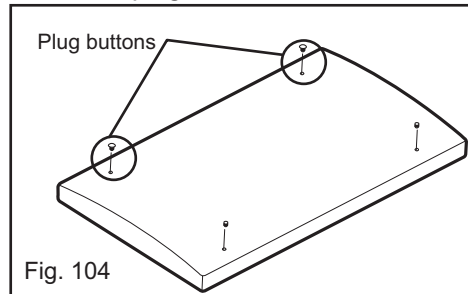

- Install the handle mounting screws on the right side.

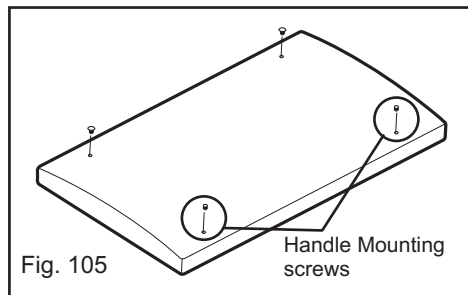

- Align the keyhole slots on the door handle to the handle mounting screws on the door and grasping the handle with both hands, press it firmly against the front of the door and slide the handle down. This may require some force.

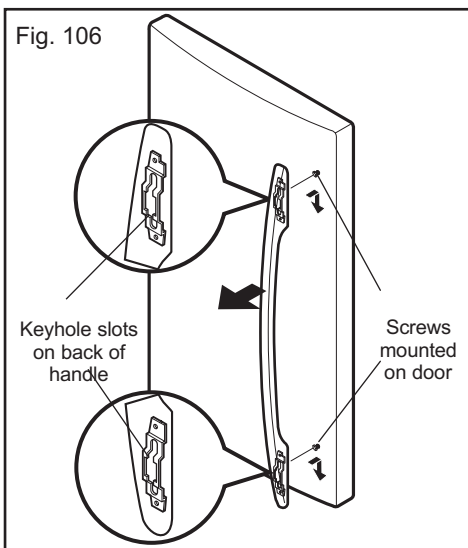

### 3-9 AFTER COMPLETING THE JOB

Make sure that the four corners of the door gasket are not folded over. To ensure a good seal, apply a small amount of silicon grease on the gasket.

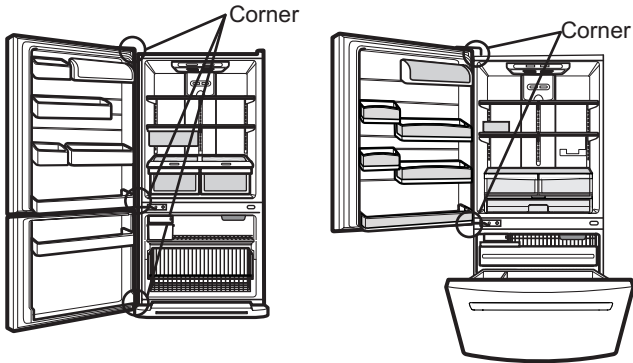

4. Open both doors again and check to make sure that they close easily. If not, tilt the refrigerator slightly more to the rear by turning both Leveling Screws clockwise. It may take several more turns, and you should turn both Leveling Screws the same amount.

5. Replace the base grille. Place level tool on refrigerator shelf as shown below to check if until is level.

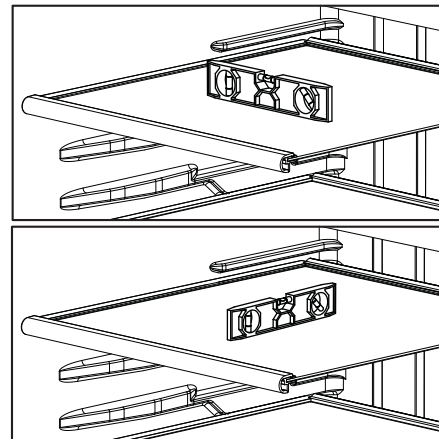

### 3-10 LEVELING AND DOOR CLOSING

To avoid vibration, the unit must be leveled. If necessary adjust the Leveling Legs to compensate for unevenness of the floor. The front should be slightly higher than the rear to aid in door closing.

Your refrigerator has two Front Leveling Screws - one on the right and one on the left. If your refrigerator seems unsteady or you want the doors to close more easily, adjust the refrigerator's tilt using the instruction below:

1. Plug refrigerator power cord into a 3-prong grounded outlet. Move the refrigerator into its final position.
2. Remove the base grille. The two Leveling screws are located on the bottom of the refrigerator on either side.
3. Insert a flat screwdriver in slots to adjust the Leveling Screws. Turn the leveling screw clockwise to raise the side of the refrigerator or counterclockwise to lower it. It may take several turns of the Leveling screw to adjust the tilt of the refrigerator.

**NOTE:** Having someone push against the top of the refrigerator takes some of the weight off the Leveling Screws. This makes it easier to adjust the screws.

### 3-11 DOOR ALIGNMENT

If the space between your doors is uneven, follow the instructions below to align the doors:

1. Gently pry off the Top Hinge Cover with a flat head screwdriver and remove. Loosen the Top Hinge Bolts using a 10mm or 13/32 in socket wrench or open-end wrench.
2. Have someone hold the freezer door so the space between the two doors is even, and retighten the top hinge bolts.
3. Replace the top hinge Cover.

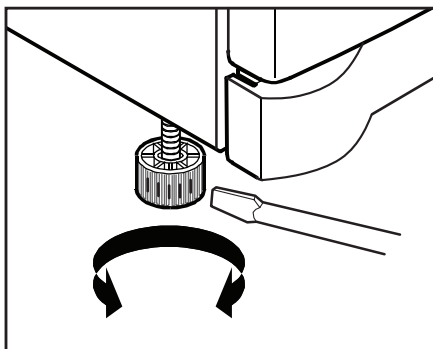

# 4. ADJUSTMENT

## 4-1 COMPRESSOR

### 4-1-1 Role

The compressor intakes low temperature and low pressure gas from the evaporator of the refrigerator and compresses this gas to high-temperature and high-pressure gas. It then delivers the gas to the condenser.

### 4-1-2 Composition

The compressor includes overload protection. The PTC starter and OLP (overload protector) are attached to the outside of the compressor. Since the compressor is manufactured to tolerances of 1 micron and is hermetically sealed in a dust and moisture-free environment, use extreme caution when repairing it.

### 4-1-3 Note for Usage

- (1) Be careful not to allow over-voltage and over-current.
- (2) If compressor is dropped or handled carelessly, poor operation and noise may result.
- (3) Use proper electric components appropriate to the Particular Compressor in your product.
- (4) Keep Compressor dry.  
If the Compressor gets wet (in the rain or a damp environment) and rust forms in the pin of the Hermetic Terminal, poor operation and contact may result.
- (5) When replacing the Compressor, be careful that dust, humidity, and soldering flux don't contaminate the inside of the compressor. Dust, humidity, and solder flux contaminate the cylinder and may cause noise, improper operation or even cause it to lock up.

## 4-2 PTC-STARTER

### 4-2-1 Composition of PTC-Starter

- (1) PTC (Positive Temperature Coefficient) is a no-contact semiconductor starting device which uses ceramic material consisting of BaTiO<sub>3</sub>.
- (2) The higher the temperature is, the higher the resistance value. These features are used as a starting device for the Motor.

### 4-2-2 Role of PTC-Starter

- (1) The PTC is attached to the Sealed Compressor and is used for starting the Motor.
- (2) The compressor is a single-phase induction motor. During the starting operation, the PTC allows current flow to both the start winding and main winding.

### 4-2-3 PTC-Applied Circuit Diagram Starting Method for the Motor

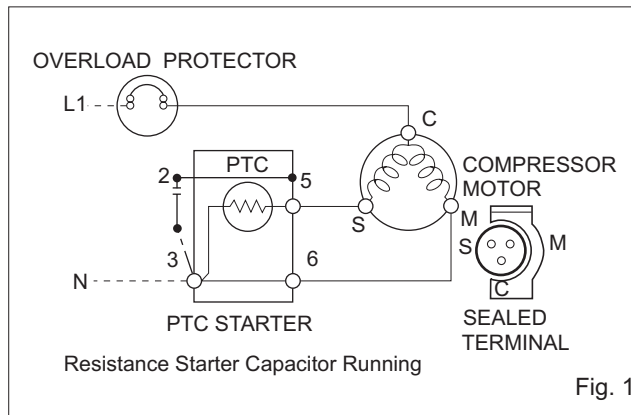

### 4-2-4 Motor Restarting and PTC Cooling

- (1) It requires approximately 5 minutes for the pressure to equalize before the compressor can restart.
- (2) The PTC device generates heat during operation. Therefore, it must be allowed to cool before the compressor can restart.

### 4-2-5 Relation of PTC-Starter and OLP

- (1) If the compressor attempts to restart before the PTC device is cooled, the PTC device will allow current to flow only to the main winding.
- (2) The OLP will open because of the over current condition. This same process will continue (3 to 5 times) when the compressor attempts to restart until the PTC device has cooled. The correct OLP must be properly attached to prevent damage to the compressor.

Parts may appear physically identical but could have different electrical ratings. Replace parts by part number and model number. Using an incorrect part could result in damage to the product, fire, injury, or possibly death.

### 4-2-6 Note for Using the PTC-Starter

- (1) Be careful not to allow over-voltage and over-current.
- (2) Do not drop or handle carelessly.
- (3) Keep away from any liquid.  
If liquid such as oil or water enters the PTC, PTC materials may fail due to breakdown of their insulating capabilities.
- (4) If the exterior of the PTC is damaged, the resistance value may be altered. This can cause damage to the compressor and result in a no-start or hard-to-start condition.
- (5) Always use the PTC designed for the compressor and make sure it is properly attached to the compressor. Parts may appear physically identical but could have different electrical ratings. Replace parts by part number and model number. Using an incorrect part could result in damage to the product, fire, injury, or possibly death.

## 4-3 OLP (OVERLOAD PROTECTOR)

### 4-3-1 Definition of OLP

- (1) OLP (OVERLOAD PROTECTOR) is attached to the Compressor and protects the Motor by opening the circuit to the Motor if the temperature rises and activating the bimetal spring in the OLP.
- (2) When high current flows to the Compressor motor, the Bimetal works by heating the heater inside the OLP, and the OLP protects the Motor by cutting off the current flowing to the Compressor Motor.

### 4-3-2 Role of the OLP

- (1) The OLP is attached to the Sealed Compressor used for the Refrigerator. It prevents the Motor Coil from being started in the Compressor.
- (2) For normal operation of the OLP, do not turn the Adjust Screw of the OLP in any way.

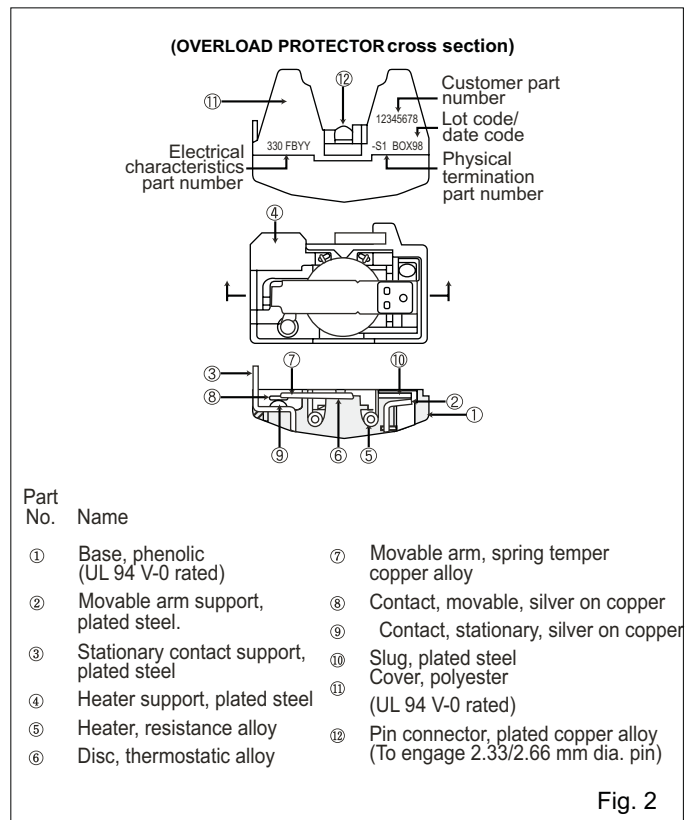

# 5. CIRCUIT DIAGRAM

## 5-1 For Drawer Type Models

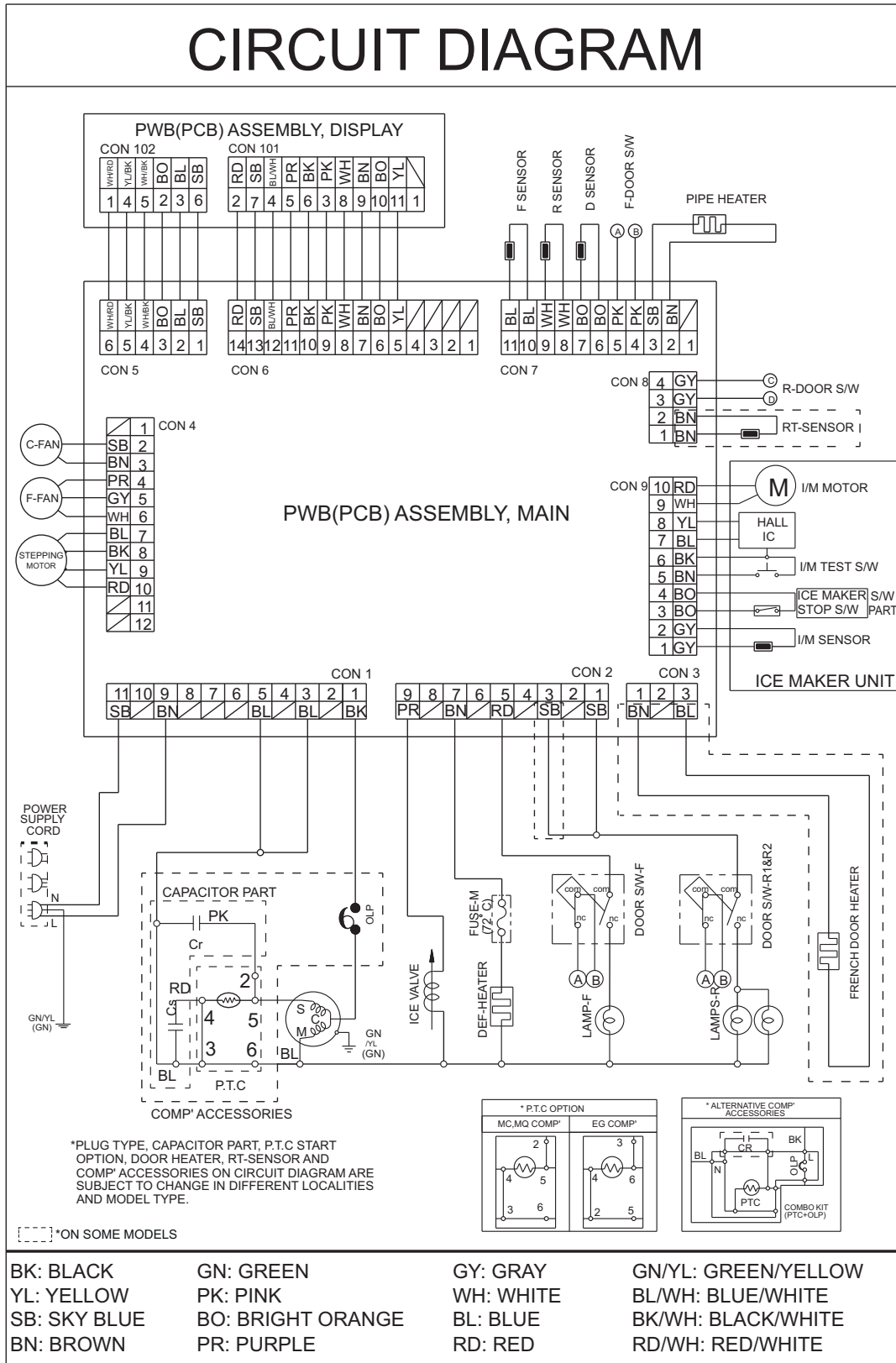

## 5-2 For Swing Type Models

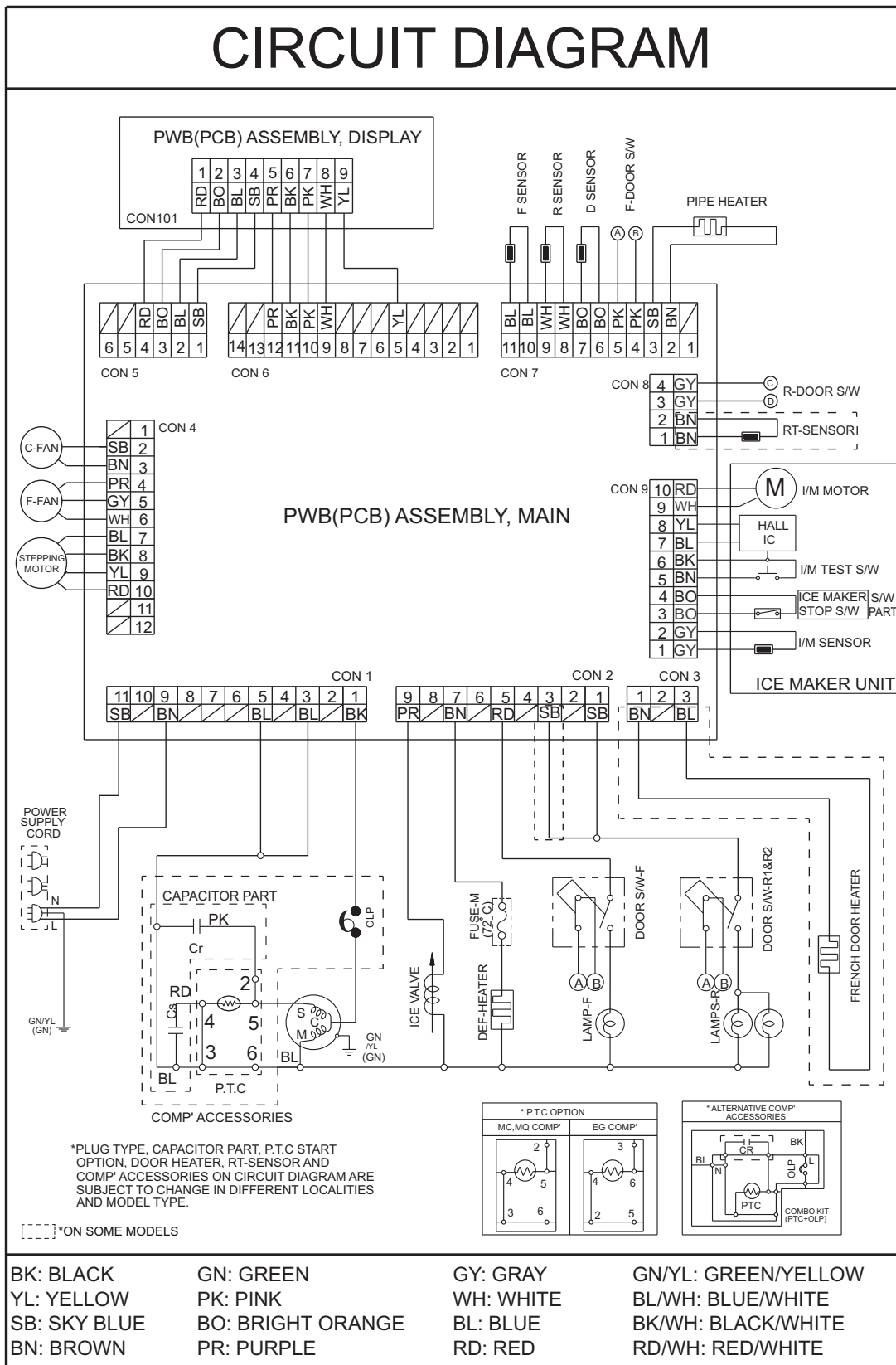

# 6. TROUBLESHOOTING

## 6-1. COMPRESSOR AND ELECTRIC COMPONENTS

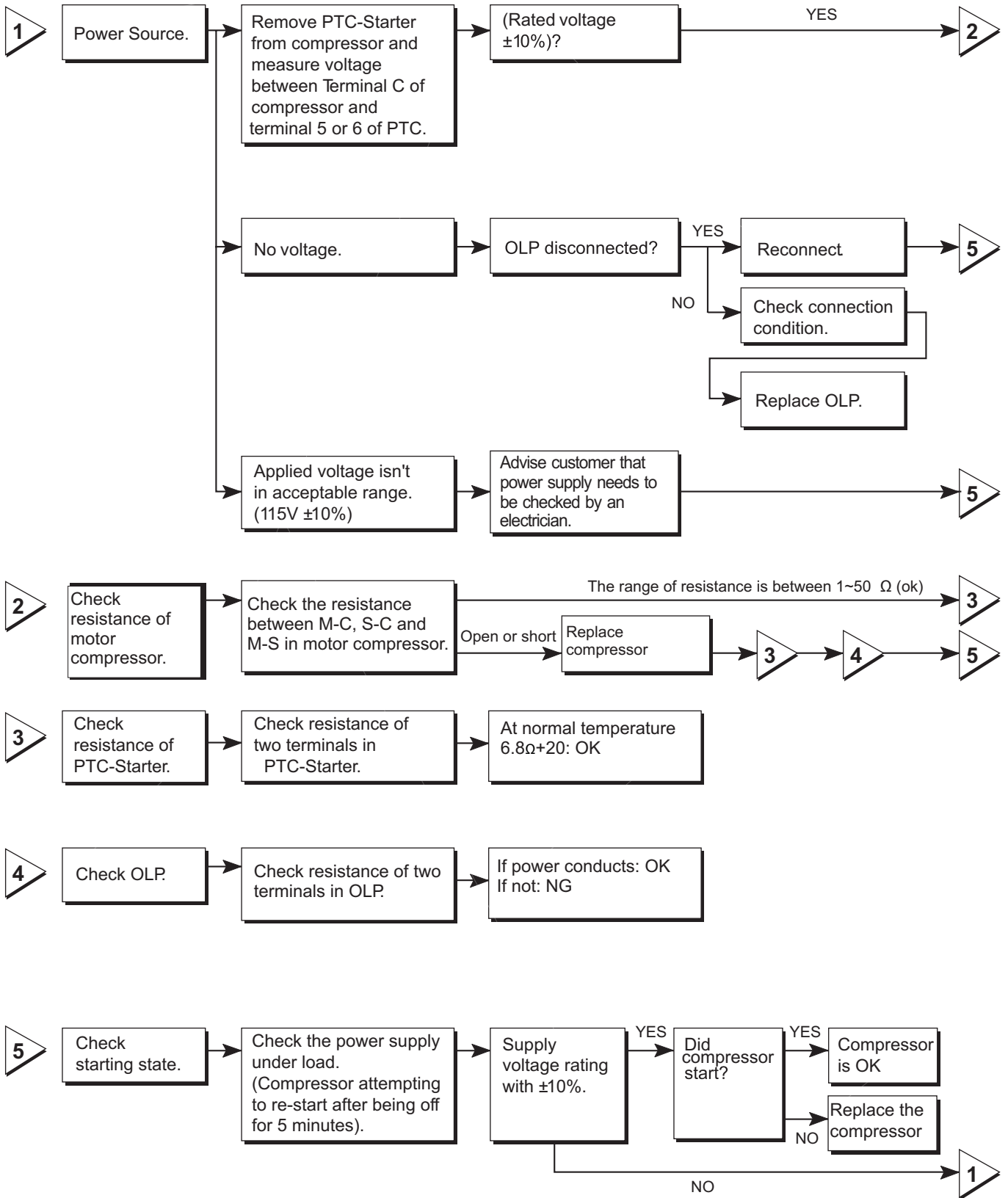

## 6-2. PTC AND OLP

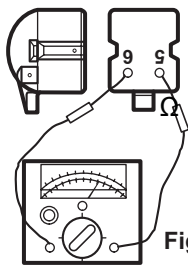
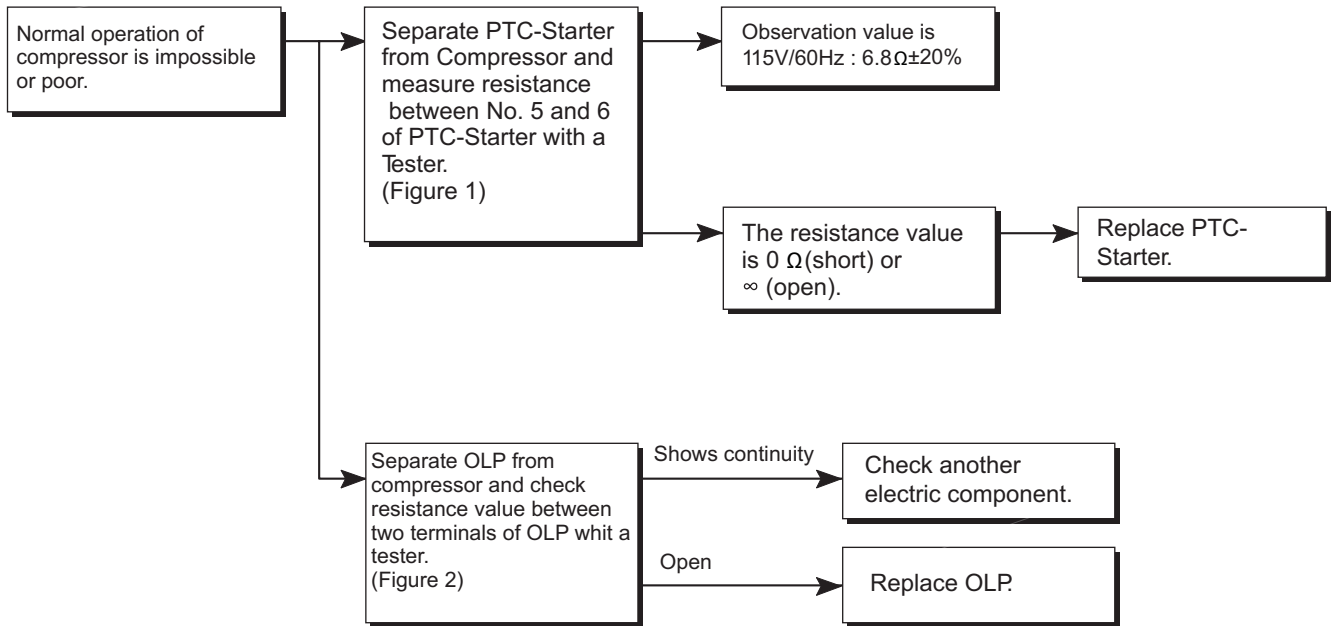

Figure 1

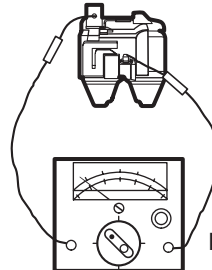
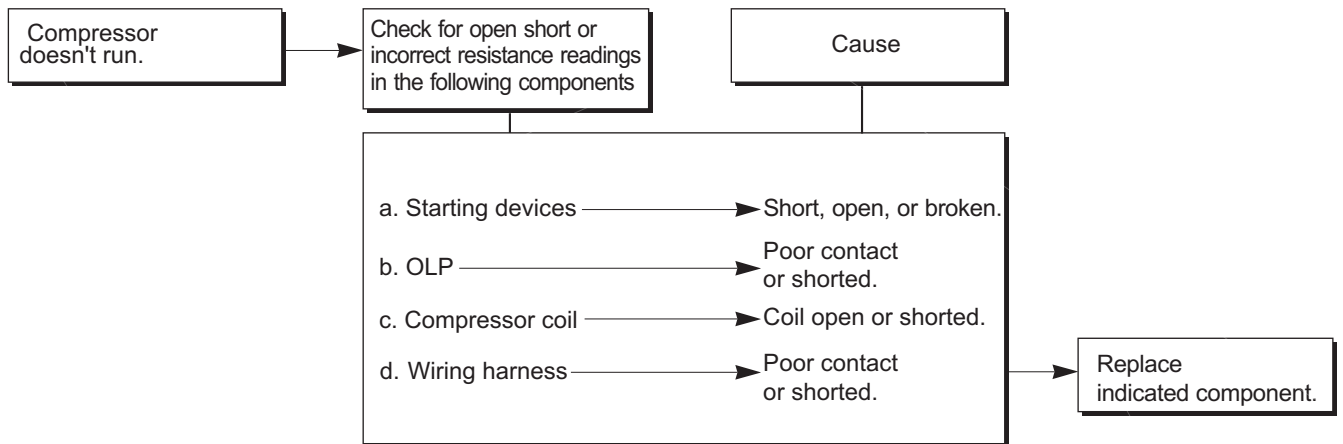

Figure 2

## 6-3 OTHER ELECTRICAL COMPONENTS

### • Not cooling at all



### • Poor cooling performance

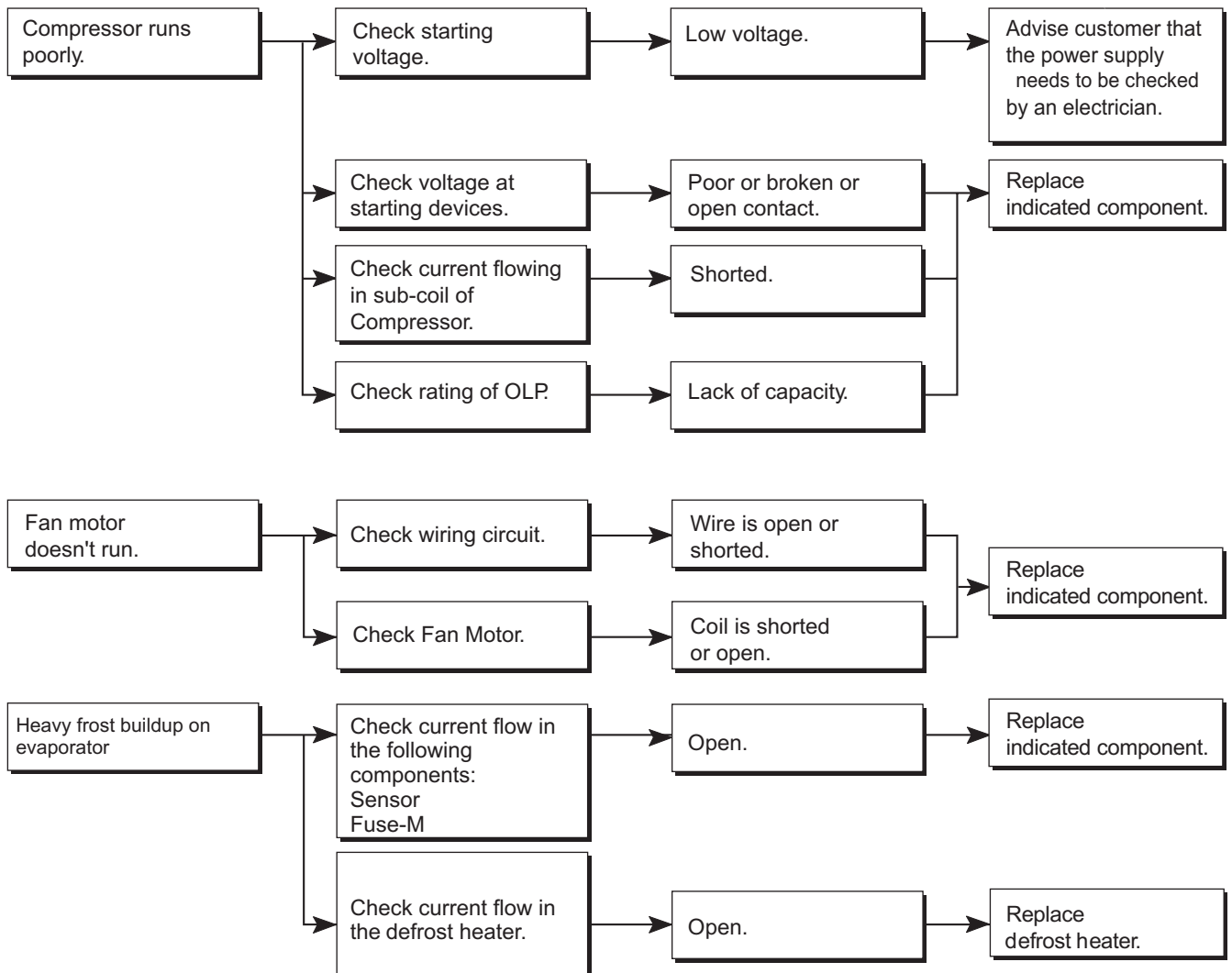

## 6-4 SERVICE DIAGNOSIS CHART

COMPLAINT	POINTS TO BE CHECKED	REMEDY
No Cooling.	<ul style="list-style-type: none"> <li>• Is the power cord unplugged from the outlet?</li> <li>• Check if the power switch is set to OFF.</li> <li>• Check if the fuse of the power switch is shorted.</li> <li>• Measure the voltage of the power outlet.</li> </ul>	<ul style="list-style-type: none"> <li>• Plug into the outlet.</li> <li>• Set the switch to ON.</li> <li>• Replace the fuse.</li> <li>• If the voltage is low, correct the wiring.</li> </ul>
Cools poorly.	<ul style="list-style-type: none"> <li>• Check if the unit is placed too close to the wall.</li> <li>• Check if the unit is placed too close to the stove, gas cooker, or in direct sunlight.</li> <li>• Is the ambient temperature too high or the room door closed?</li> <li>• Check if food put in the refrigerator is hot.</li> <li>• Did you open the door of the unit too often or check if the door is sealed properly?</li> <li>• Check if the Control is set to <b>Warm position</b>.</li> </ul>	<ul style="list-style-type: none"> <li>• Place the unit about 4 inches (10 cm) from the wall.</li> <li>• Place the unit away from these heat sources.</li> <li>• Lower the ambient temperature.</li> <li>• Put in foods after they have cooled down.</li> <li>• Don't open the door too often and close it firmly.</li> <li>• Set the control to <b>Recommended position</b>.</li> </ul>
Foods in the Refrigerator are frozen.	<ul style="list-style-type: none"> <li>• Is food placed in the cooling air outlet?</li> <li>• Check if the control is set to <b>colder position</b>.</li> <li>• Is the ambient temperature below 41°F(5°C)?</li> </ul>	<ul style="list-style-type: none"> <li>• Place foods in the high-temperature section. (front part)</li> <li>• Set the control to <b>Recommended position</b>.</li> <li>• Set the control to <b>Warm position</b>.</li> </ul>
Condensation or ice forms inside the unit.	<ul style="list-style-type: none"> <li>• Is liquid food sealed?</li> <li>• Check if food put in the refrigerator is hot.</li> <li>• Did you open the door of the unit too often or check if the door is sealed properly?</li> </ul>	<ul style="list-style-type: none"> <li>• Seal liquid foods with wrap.</li> <li>• Put in foods after they have cooled down.</li> <li>• Don't open the door too often and close it firmly.</li> </ul>
Condensation forms in the Exterior Case.	<ul style="list-style-type: none"> <li>• Check if the ambient temperature and humidity of the surrounding air are high.</li> <li>• Is there a gap in the door gasket?</li> </ul>	<ul style="list-style-type: none"> <li>• Wipe moisture with a dry cloth. It will disappear in low temperature and humidity.</li> <li>• Fill up the gap.</li> </ul>
There is abnormal noise.	<ul style="list-style-type: none"> <li>• Is the unit positioned in a firm and even place?</li> <li>• Are any unnecessary objects placed in the back side of the unit?</li> <li>• Check if the Tray Drip is not firmly fixed.</li> <li>• Check if the cover of the compressor enclosure in the front lower side is taken out.</li> </ul>	<ul style="list-style-type: none"> <li>• Adjust the Leveling Screw, and position the refrigerator in a firm place.</li> <li>• Remove the objects.</li> <li>• Fix the Tray Drip firmly in the original position.</li> <li>• Place the cover in its original position.</li> </ul>
Door does not close well.	<ul style="list-style-type: none"> <li>• Check if the door gasket is dirty with an item like juice.</li> <li>• Is the refrigerator level?</li> <li>• Is there too much food in the refrigerator?</li> </ul>	<ul style="list-style-type: none"> <li>• Clean the door gasket.</li> <li>• Position in the firm place and level the Leveling Screw.</li> <li>• Make sure food stored in shelves does not prevent the door from closing.</li> </ul>
Ice and foods smell unpleasant.	<ul style="list-style-type: none"> <li>• Check if the inside of the unit is dirty.</li> <li>• Are foods with a strong odor unwrapped?</li> <li>• The unit smells of plastic.</li> </ul>	<ul style="list-style-type: none"> <li>• Clean the inside of the unit.</li> <li>• Wrap foods that have a strong odor.</li> <li>• New products smell of plastic, but this will go away after 1-2 weeks.</li> </ul>

• Other possible problems:

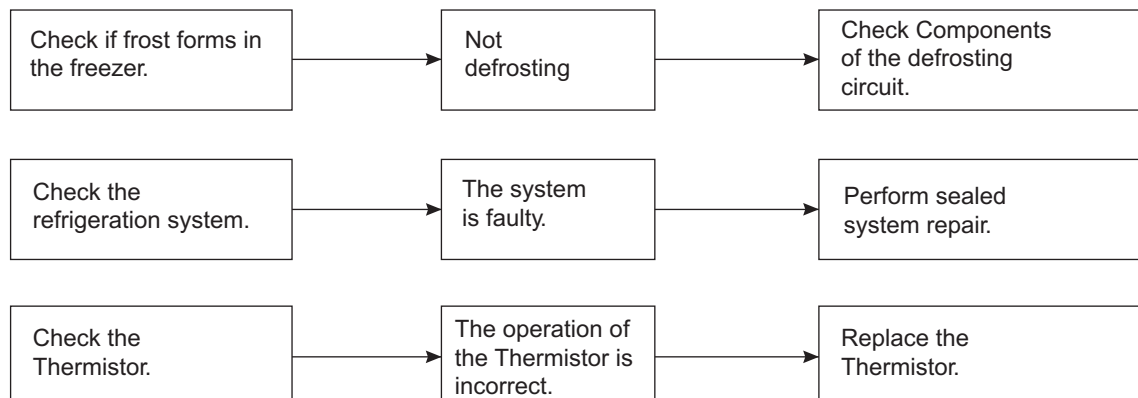

## 6-5 REFRIGERATION CYCLE

### • Troubleshooting Chart

CAUSE		STATE OF THE UNIT	STATE OF THE EVAPORATOR	TEMPERATURE OF THE COMPRESSOR	REMARKS
LEAKAGE	PARTIAL LEAKAGE	Freezer compartment and refrigerator don't cool normally	Low flowing sound of refrigerant is heard and frost forms in inlet only.	A little higher than ambient temperature.	- Refrigerant level is low due to a leak. - Normal cooling is possible by restoring the normal amount of refrigerant and repairing the leak.
	COMPLETE LEAKAGE	Freezer compartment and refrigerator don't cool normally	Flowing sound of refrigerant is not heard and frost isn't formed.	Equal to ambient temperature.	- No discharging of refrigerant. - Normal cooling is possible by restoring the normal amount of refrigerant and repairing the leak.
RESTRICTION	PARTIAL RESTRICTION	Freezer compartment and refrigerator don't cool normally	Flowing sound of refrigerant is heard and frost forms in inlet only.	A little higher than ambient temperature.	- Normal discharging of the refrigerant. - The capillary tube is faulty.
	COMPLETE RESTRICTION	Freezer compartment and refrigerator don't cool.	Flowing sound of refrigerant is not heard and frost isn't formed.	Equal to ambient temperature.	- Normal discharging of the refrigerant.
MOISTURE RESTRICTION		Cooling operation stops periodically.	Flowing sound of refrigerant is not heard and frost melts.	Lower than ambient temperature.	- Cooling operation restarts when heating the inlet of the capillary tube.
DEFECTIVE COMPRESSION	COMPRESSSION	Freezer and refrigerator don't cool.	Low flowing sound of refrigerant is heard and frost forms in inlet only.	A little higher than ambient temperature.	- Low pressure at high side of compressor due to low refrigerant level.
	NO COMPRESSSION	No compressing operation.	Flowing sound of refrigerant is not heard and there is no frost.	Equal to ambient temperature	- No pressure in the high pressure part of the compressor.

6-5-1 SEALED SYSTEM DIAGNOSIS

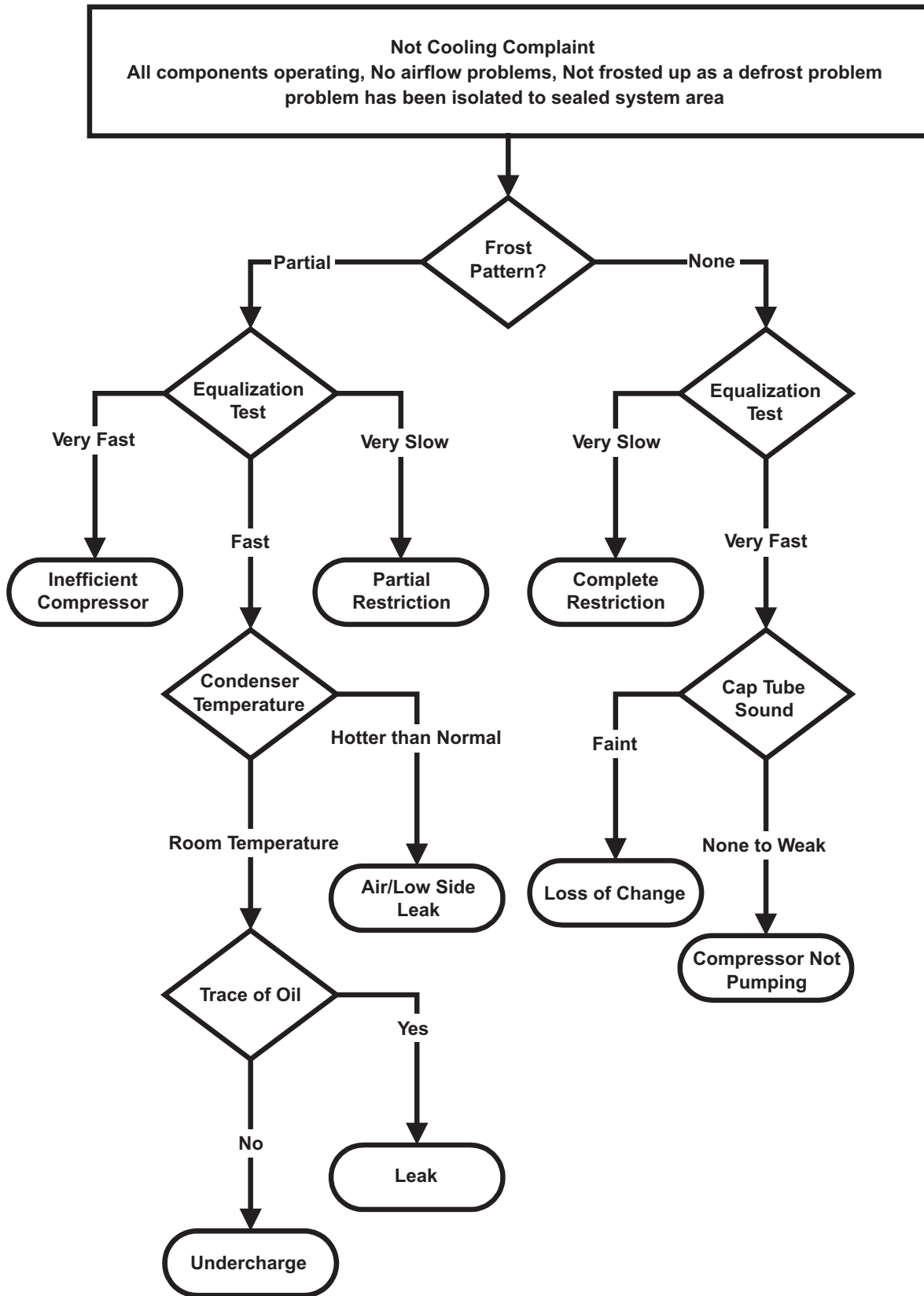

(The equalization test is trying to restart a compressor after it has been operating.)

# 7. OPERATION PRINCIPLE AND REPAIR METHOD OF ICEMAKER

## 7-1 OPERATION PRINCIPLE

### 7-1-1 Operation Principle of Icemaker

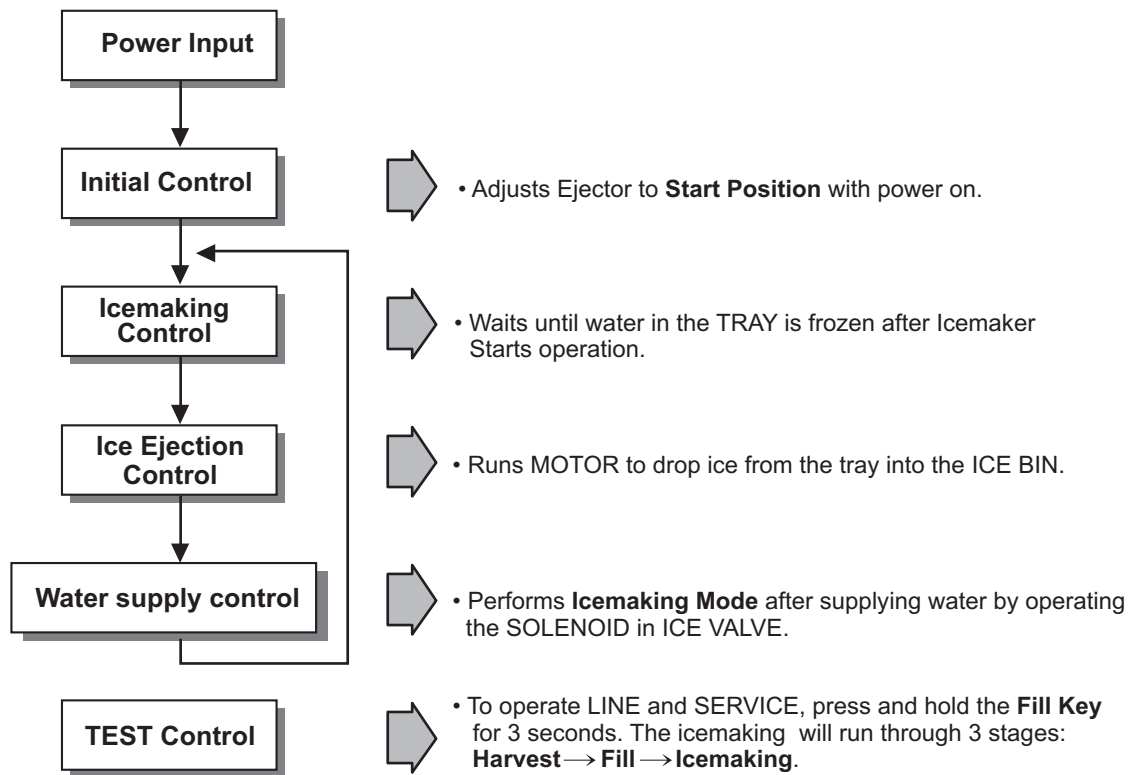

1. Turning the Icemaker stop switch off (O) stops the icemaking function.
2. Setting the Icemaker switch to OFF and then turning it back on will reset the icemaker control.

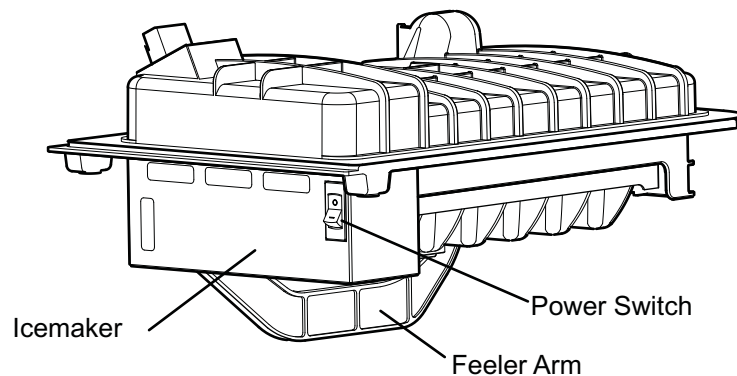

---

## 7-2 ICEMAKER FUNCTIONS

### 7-2-1 Start Position

- 1) When power is initially applied or reapplied after power is cut, it detects level of the TRAY after completion of MICOM initialization. The detecting lever moves up and down.
- 2) The level of icemaker tray is judged by output signal, high and low signal, of HALL SENSOR. Make the tray to horizontal by rotating ice ejection motor in normal or reverse direction so that High/Low signal can be applied to MICOM Pin (P22).
- 3) If there is no change in signals one minute after the geared motor starts to operate, it stops icemaker operation and check the signal every hour. It resets initialization of icemaker when it becomes normal. Ice ejection conducts for 1 cycle.

### 7-2-2 Icemaking Mode

- a) Ice making control is carried out from the completion of water supply to the completion of ice making in the TRAY. Ice making sensor detects the temperature of TRAY and completes ice making. (Ice making sensor is fixed below the TRAY.)
- b) Ice making control starts after completion of water supply control or initial control. Under the ice making control, the F room temperature should be operated with the NOTCH of "Normal/Strong".
- c) It is judged that ice making is completed when ice making sensor temperature reaches at -8 after 70 minutes + 10 minutes when water is supplied to the TRAY.

### 7-2-3 Ice Ejection Mode

- a) This is to eject ice from the TRAY after ice making is completed.
- b) If Hall IC signal is on within 3.6 seconds after ice ejection motor rotates in normal direction, it does not proceed ice ejection but waits. If the ice bank is full, ice ejection motor rotates in normal direction in every hour to check the condition of ice bank. If the ice bank is not full, the water supply control starts after completion of ice ejection control. If the ice bank is full, ice ejection motor rotates in reverse direction and stops under ice making or waiting conditions.
- c) If ice bank is not full, ice ejection starts. The TRAY tilts to the maximum and ice is separated from the TRAY and ice checking lever raises.
- d) Ice ejection motor stops for 1 second if Hall IC signal changes from OFF (low) to ON (high) after 3.6 seconds when ice ejection motor rotates in normal direction. If there is no change in Hall IC signals within 1 minute after ice ejection motor operates, ice ejection motor stops as ice ejection motor or hall IC is out of order.
- e) If ice ejection motor or Hall IC is abnormal, ice ejection motor rotates in normal direction to exercise initial operation in every hour. It resets the ice maker if ice ejection motor or Hall IC is normal.
- f) The TRAY stops for 1 second at maximum tilted conditions.
- g) The TRAY returns to horizontal conditions as ice ejection motor rotates in reverse direction.
- h) When the TRAY becomes horizontal, the cycle starts to repeat.  
Water Supply – Ice making – Ice ejection – TRAY returns to Horizontal.

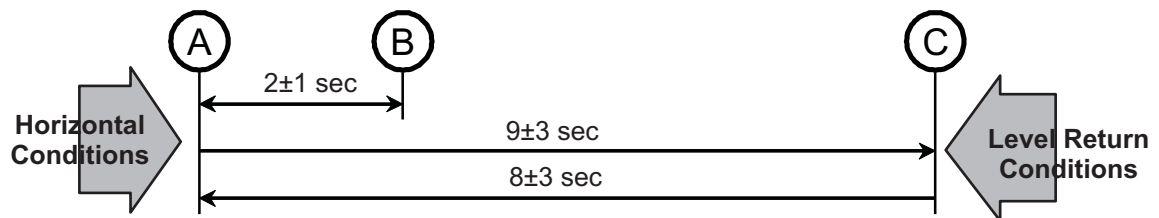
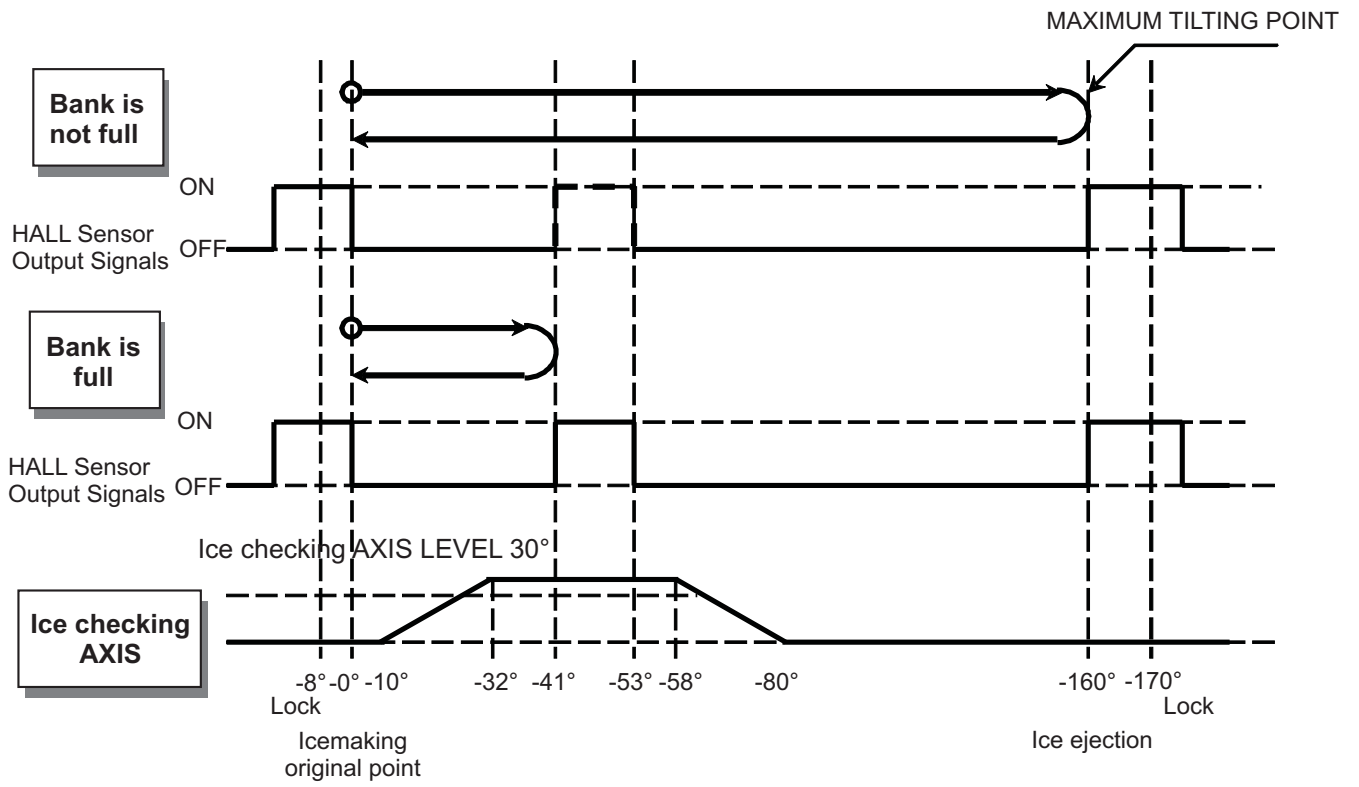

### 7-2-4 Test Icemaker Mode

Test function starts when test switch is pressed for more than **3 seconds**. User shouldn't force operation while doing test mode, service or cleaning.

Test switch will work only when ice tray its in horizontal position, not during ice ejection or water supplying.

When pressing the Test Switch, feeler arm will sense and then ice tray will start ice ejection, after twisting, ice tray returns to initial position. When returning to horizontal position, water supply will start feeling the ice tray. After this, test mode its done.

Test mode cycle elapsed time of 30 seconds its shown as the next sequence:  
 Feeler arm sensing – Ice ejecting – Ice tray returns to horizontal position – Water supply.

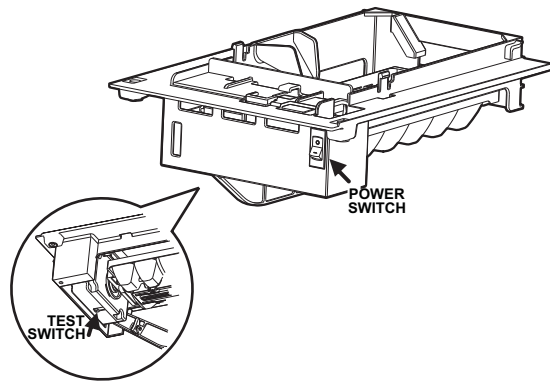

### 7-2-5 Water Supply Function

This function is for supply water to tray ,by the mechanic water valve ,when ice ejecting finish and tray return to initial position.

Water supply quantity depend of DIP S W.

#### Water Supply Time Table

No	DISP S/W		Water Supply Time	Note
	S1	S2		
1	OFF	OFF	9.0	DIP S/W Setting will be depend of water pressure
2	ON	OFF	8.0	
3	OFF	ON	10.0	
4	ON	ON	11.0	

If water supply setting is changed while system is energized, change will be made immediately. But if change occurs when water supply function is working, change will be executed next cycle of icemaker

### 7-2-6 Ice maker stop switch

- Ice Maker Stop S/W ON state, Ice Maker normal operation
- Ice Maker Stop S/W OFF state: Ice Maker do not operate

# 8. CIRCUIT OF MICOM (DRAWER TYPE MODELS)

## 8-1 FUNCTION

### 8-1-1 Function

1. Initially set the Refrigerator control at 37°F (3°C) and the Freezer control at 0°F (-18°C)  
You can adjust the Refrigerator and the Freezer control temperature by pressing the Colder ADJUST button.
2. When the power is restored after a power failure, it is automatically set to last setting selected.

\*Note: To ERROR CODE on display panel refer to page 41.



### 8-1-2 How to Toggle the Display between °F & °C

1. The display temperature mode can be changed from °F to °C or °C to °F by pressing and holding the COLDER FREEZER TEMP and the COLDER REFRIGERATOR TEMP keys at the same time for over one second.
2. The initial setting is °F. Whenever the mode is changed, the appropriate LED is it.

### 8-1-3 Control of freezer fan motor

1. Freezer fan motor runs at either regular or high speed (2,400 or 2,700 rpm.)
2. High RPM is used when electricity is first on, for ULTRA ICE, and when refrigerator is overloaded. Standard RPM is used for normal usage.
3. The fan motor is stopped when refrigerator door is opened

### 8-1-4 ULTRA ICE

1. The purpose of this function is to intensify the cooling speed of freezer and to increase the amount of ice.
2. Whenever selection switch is pressed, selection/release, the LED will turn ON or OFF.
3. If there is a power outage and the refrigerator is powered on again, ULTRA ICE will be canceled.
4. To activate this function you need to press the ULTRA ICE key and the LED will turn ON. This function will remain activated for 24 hrs. The first three hours the compressor and Freezer Fan will be ON. The next 21hours the freezer will be controlled at the lowest temperature. After 24 hours or if the ULTRA ICE key is pressed again, the freezer will return to its previous temperature.
5. During the first 3 hours:
  - (1) Compressor and freezer fan (HIGH RPM) run continuously.
  - (2) If a defrost cycle begins during the first 90 minutes of ULTRA ICE , the ULTRA ICE cycle will complete its cycle after defrosting has ended. If the defrost cycle begins when ULTRA ICE has run for more than 90 minutes, ULTRA ICE will run for two hours after the defrost is completed.
  - (3) If ULTRA ICE is pressed during defrost, ULTRA ICE is on, this function will start seven minutes after defrost is completed and it shall operate for three hours.
  - (4) If ULTRA ICE is selected within seven minutes after compressor has stopped, the compressor (compressor delays seven minutes) will start after the balance of the delay time.
  - (5) The fan motor in the freezer compartment rotates at high speed during ULTRA ICE.
6. For the rest of 21 hours, the freezer will be controlled at the lowest temperature.

### 8-1-5. Refrigerator Lamp Auto Off

1. To protect the risk of lamp heat, when Refrigerator door opens for 7 min., refrigerator lamp is auto off.

### 8-1-6 Alarm for Open Door

1. This feature sounds a buzzer when the freezer or refrigerator door is not closed within 1 minute after it is opened.
2. One minute after the door is opened, the buzzer sounds three times each for 1/2 seconds. These tones repeat every 30 seconds.
3. The alarm is cancelled when the freezer or the refrigerator is closed while the buzzer sounds.

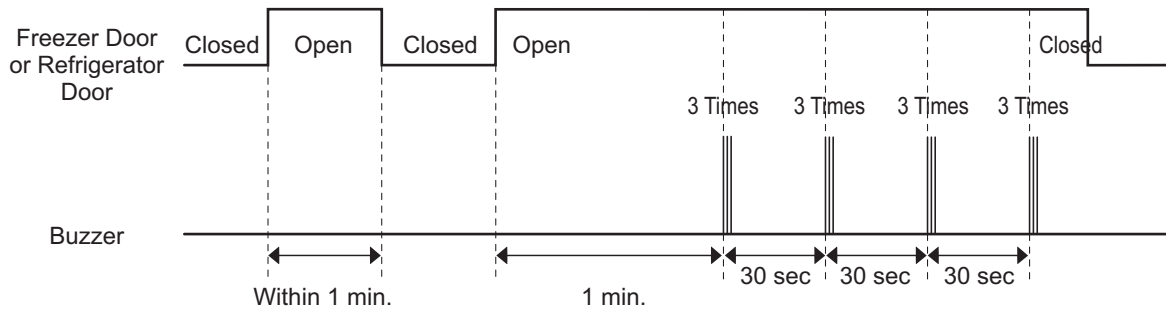

### 8-1-7 Buzzer Sound

When the button on the front Display is pushed, a Ding~ Dong~ sound is produced.

### 8-1-8 Defrosting (removing frost)

1. Defrosting starts each time the COMPRESSOR running time reaches 7 hours.
2. For initial power on or for restoring power, defrosting starts when the compressor running time reaches 4 hours.
3. Defrosting stops if the sensor temperature reaches 46.4°F(8°C) or more. If the sensor doesn't reach 46.4°F(8°C) in 2 hours, the defrost mode is malfunctioning. (Refer to the defect diagnosis function, 8-1-9.)
4. Defrosting won't function if its sensor is defective (wires are cut or short circuited)

### 8-1-9 Electrical Parts Are Turned On Sequentially

Electrical parts such as COMP, defrosting heater, freezer FAN, etc. are turned on in the following order to prevent noise and parts damage. Several parts are started at the same time at initial power on and are turned off together when TEST is completed.

OPERATING		ORDERS				
Initial power on	Temperature of Defrosting Sensor is 45°C or more (when unit is newly purchased or when moved)	<b>POWER ON</b>	in 1/2 second →	<b>COMP ON</b>	in 1/2 second →	<b>Freezer FAN ON</b>
	Temperature of defrosting sensor is lower than 45°C (when power cuts, SERVICE)	<b>POWER ON</b>	in 1/2 second →	<b>Defrosting heater ON</b>	in 10 second →	<b>Defrosting heater OFF</b>
		in 1/2 second →	<b>COMP ON</b>	in 1/2 second →	<b>Freezer FAN ON</b>	
Reset to normal operation from TEST MODE		<b>Total load OFF</b>	in 7 minute →	<b>COMP ON</b>	in 1/2 second →	<b>Freezer FAN ON</b>

## 8-1-10 Defect Diagnosis Function

Micom error are separated in "Main Errors" (Affect directly refrigerator performance) and "Secondary Errors" (don't affect the refrigerator performance).

To check in Display the error present, is necessary press Cold key on freezer and Cold key on refrigerator more than 1 Second, if no there any error, all LED will be illuminated, if a main error is present, only certain LED will be illuminated, in case of secondary errors, only one LED or icon will not illuminated.



### ERROR CODE on display panel

No.	Item	Error Indication		Contents	Remarks
1	Normal	NOTCH Indication		None	DISPLAY switch operates normally
2	Failure of Freezer sensor	Er	Fs	Cut or short circuit wire	Inspect Connecting wires on each sensor
3	Failure of Refrigerator sensor	Er	rS	Cut or short circuit wire	
4	Failure of Defrost sensor	Er	dS	Cut or short circuit wire	
5	Failure of Defrost mode	Er	dH	When defrost sensor does not reach 8°C within 1 hour after starting defrost.	Snapping of defrost heater or temperature fuse, pullout of connector (indicated minimum 2h after a failure occurs)
6	Failura of BLDC fan motor at freezing compartment	Er	FF	If there is no fan motor signal for more than 115 sec in operation fan motor.	Poor motor, hooking to wires of fan, contact of structures to fan, snapping or short circuit of lead wires.
7	Failure of Icemaker Kit	Er	It	Failure of wires such as motor in I/M KIT GEAR, HALL IC	When the ice ejecting does not operated on pressing the I/M TEST S/W
8	Failure of Icemaker sensor	Er	IS	Snapping or short circuit of ice making sensor	Connecting wire Test On Sensor

**Primary Error:** F sensor, R1 sensor, D sensor, defrost errors, F-FAN errors.

**Secondary Error:** I / M sensors, I / M Kit

When an error occur the first 3 hours the Primary Error and Secondary Error is indicated in the display check mode (Pressing Cold key on freezer and Cold key on refrigerator more than 1 Second). After the 3 hours and if the error is still present the Primary Error will show in the display automatically (See Note 1) and the Secondary Error is indicated in the display check mode.

Note1: In the Primary Error after 3 hours of the error occur all display lights turn OFF except the Freezer Temperature (Trouble Code Index) indicating the failure mode.

\*LED check function: When there's no error, If simultaneously pressing the Cold key of refrigerator Temp and the Cold key of freezer temp for a second, all display LED graphics on. If releasing the button, the LED graphics displays the previous status.

## 8-1-11 TEST Mode

1. The Test mode allows checking the PCB and the function of the product as well as finding out the defective part in case of an error.
2. The test mode is operated by pressing two buttons on the Display panel.
3. While in the test mode, the function control button is not recognized, but the recognition tone (beep~) sounds.
4. After exiting the test mode, be sure to reset by unplugging and then plugging in the appliance.
5. If an error, such as a sensor failure, is detected while in the test mode, the test mode is cleared and the error code is displayed.
6. While an error code is displayed, the test mode will not be activated.

MODE	OPERATION	CONTENTS	REMARKS
TEST1	Push ULTRA ICE & COLDER (F) KEYS for 3 sec. Or Push TEST switch (on the main Board) Once.  <Cooling MODE>	1. Continuous operation of the compressor and the freezer fan. 2. Stepping Damper OPEN 3. Defrosting Heater OFF 4. Display LED all ON	Maximum test time: 5 minutes
TEST2	Push ULTRA ICE & COLDER (F) KEY for 3sec in TEST MODE 1 or push TEST switch once in TEST MODE 1.  < Forced defrosting MODE>	1. Compressor and the freezer fan OFF 2. Stepping Damper CLOSE 3. Defrosting heater ON 4. Display LED shows 2	Maximum test time: 2 hours. Reset if the temperature Of the defrosting sensor is 8°C (46°F) or more.
Return to Normal	On TEST 2, press ULTRA ICE & COLDER (F) KEY for 3 sec.	Return to initial status (COMP 7 min delay)	

### \* Freezer Fan RPM Variable Check:

If the freezer fan is in operation when the COLD REFRIGERATOR TEMP KEY & COLD FREEZER TEMP KEY are pressed for more than one second at the same time then the freezer fan RPM changes. (for example if high speed, to normal speed or if normal speed, to high speed for 30 seconds)  
After 30 seconds, it turns to its original RPM.

### \* Demonstration (Display) MODE:

1. To enter this mode, raise either the Refrigerator or Freezer temperature to its highest setting. Then, press that Cold key and hold for about 5 seconds..
2. The LED panels will display OFF, to indicate that the compressor, circulating fan, damper, and defrost heater are not operating.
3. The Open Door Alarm and the Lamp Auto-Off feature will work normally and can be demonstrated.
4. To reset to normal operation, press and hold either Cold Key for about 5 seconds.

# 8-2 PCB FUNCTION

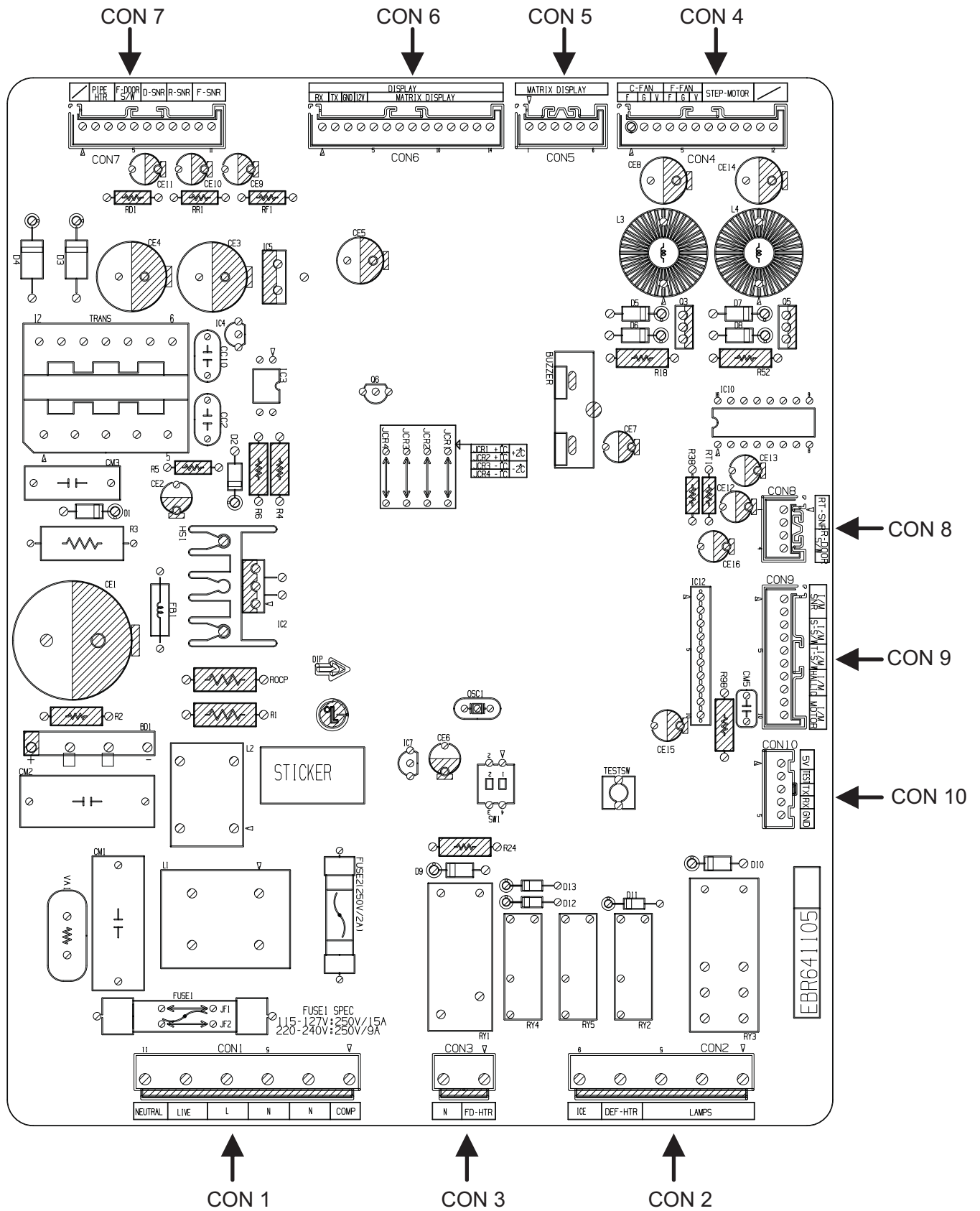

## 8-2-1 Power Circuit

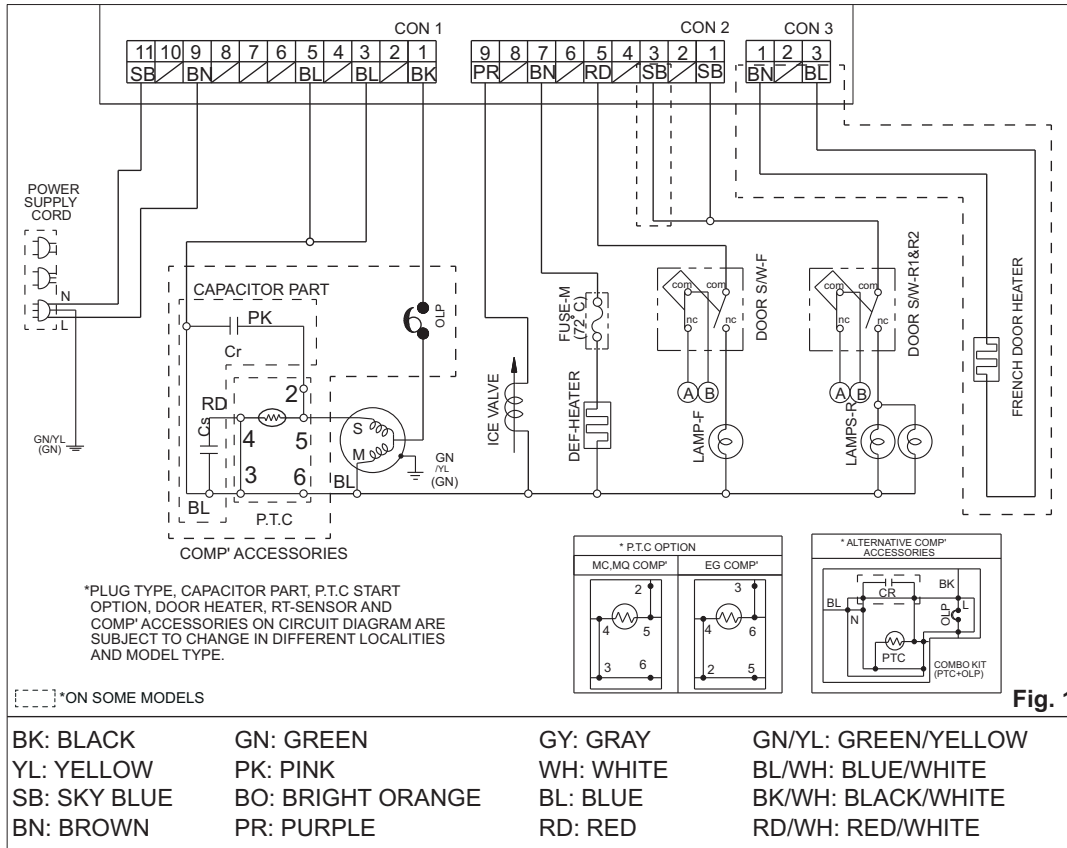

Fig. 1

## 8-2-2. Load and Door Light Circuit (HV)

### 1. Load Drive Condition Check

To measure outputs of the control board, check voltages between the pins for the following components:  
(Refer to Fig. 1).

Circuit	Pin Number	Pin Number	Output Voltage
Compressor	Con 1 Pin 1	Con 1 Pin 3	115 VAC
Defrost Heater	Con 2 Pin 7	Con 1 Pin 3	115 VAC
F Lamp	Con 2 Pin 5	Con 1 Pin 3	115 VAC
R Lamp	Con 2 Pin 1 and/or 3	Con 1 Pin 3	115 VAC
Ice Maker	Con 2 Pin 9	Con 1 Pin 3	115 VAC

Connector 1				
Pin	11	9	3	1
	N	L	N	COMP

Connector 2					
Pin	9	7	5	3	1
	Ice Valve	Def Heater	F Lamp	R Lamp	

NOTE: When the door of the refrigerator is left open for 7 minutes or longer, the lamp of the refrigerator turns off automatically.

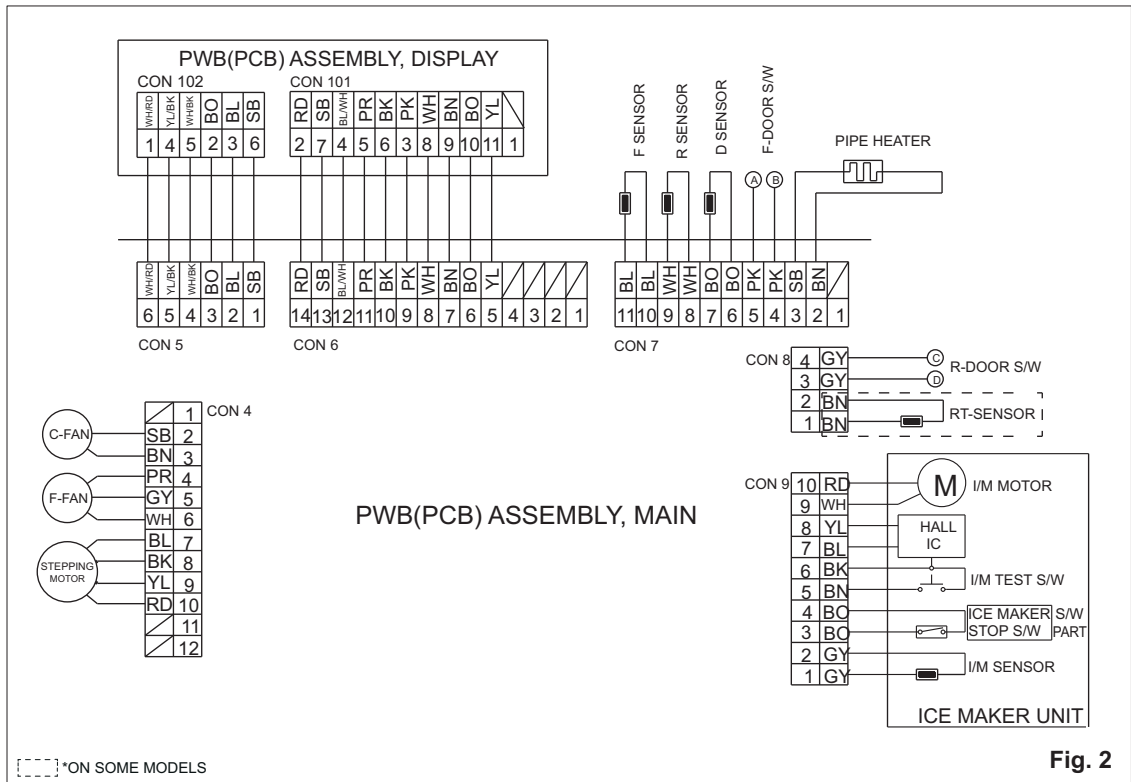

## 2. Door Monitor Circuit (LV)

Refrigerator	Pin Number	Pin Number	Voltage
F Door Close	Con 7 Pin 4	Con 7 Pin 5	5 Volts
F Door Open	Con 7 Pin 4	Con 7 Pin 5	0 Volts
R Door Close	Con 8 Pin 3	Con 8 Pin 4	5 Volts
R Door Open	Con 8 Pin 3	Con 8 Pin 4	0 Volts

Connector 8				
Pin	4	3	2	1
	R-Door S/W	NC	NC	

### 8-2-3 Temperature Sensor Circuit (Refer to Figure 2)

Voltage supplied to each sensor will range between 0.5 volts -22°F(-30°C) and 4.5 volts 122°F(50°C) depending upon the temperature in the compartments. A measurement of 0 volts indicates a short in the sensor circuit. A measurement of 5 volts indicates an open in the sensor circuit.

Connector 7											
PIN	11	10	9	8	7	6	5	4	3	2	1
	F-Sensor		R-Sensor		D-Sensor		F-Door S/W		Pipe Heater		NC

To measure the outputs of the sensors, check the voltages between the pins as in the table. And refer the values in the section "RESISTANCE SPECIFICATION OF SENSOR"

Sensor	Pin Number	Pin Number
F- Sensor	Con 7 Pin 10	Con 7 Pin 11
R- Sensor	Con 7 Pin 8	Con 7 Pin 9
D- Sensor	Con 7 Pin 6	Con 7 Pin 7
I/M Sensor	Con 9 Pin 1	Con 9 Pin 2

To measure the outputs of the fans on the control boards check the voltages between the pins for the following components:

FAN	Pin Number	Pin Number	Output Voltage	
			Motor On	Motor Off
Freezer Fan	Con 4 Pin 5	Con 4 Pin 6	10-14Vdc	2Vdc or less
Cooling Fan	con 4 Pin 2	Con 4 Pin 3	10-14Vdc	2Vdc or less

Connector 4												
PIN	12	11	10	9	8	7	6	5	4	3	2	1
	NC		Stepping Motor				F-Fan			C-Fan		NC
	NC	NC					V	G	F	V	G	NC

### 8-2-4 ICE MAKER

Connector 9										
PIN	10	9	8	7	6	5	4	3	2	1
	I/M Motor		Hall IC		I/M Test S/W		I/M Stop S/W		I/M Sensor	

Circuit	Pin Number	Pin Number	Output Voltage
I/M Stop S/W	Con 9 Pin 3	Con 9 Pin 4	0~5Vdc
I/M Test S/W	Con 9 Pin 5	Con 9 Pin 6	0~5Vdc

---

### 8-3 RESISTANCE SPECIFICATION OF SENSOR

TEMPERATURE DETECTED SENSOR	RESISTANCE OF FREEZER SENSOR	RESISTANCE OF REFRIGERATOR DEFROST SENSOR & ROOM SENSOR
-20°C	22.3 KΩ	77 KΩ
-15°C	16.9 KΩ	60 KΩ
-10°C	13.0 KΩ	47.3 KΩ
-5°C	10.1 KΩ	38.4 KΩ
0°C	7.8 KΩ	30 KΩ
+5°C	6.2 KΩ	24.1 KΩ
+10°C	4.9 KΩ	19.5 KΩ
+15°C	3.9 KΩ	15.9 KΩ
+20°C	3.1 KΩ	13 KΩ
+25°C	2.5 KΩ	11 KΩ
+30°C	2.0 KΩ	8.9 KΩ
+40°C	1.4 KΩ	6.2 KΩ
+50°C	0.8 KΩ	4.3 KΩ

- The resistance of the SENSOR has a  $\pm 5\%$  common difference.
- Measure the resistance of the SENSOR after leaving it for over 3 minutes in the measuring temperature. This delay is necessary due to sensor response speed.

# 9. CIRCUIT OF MICOM (SWING TYPE MODELS)

## 9-1 FUNCTION

### 9-1-1 Function

1. When the appliance is plugged in, it is set to "4" for Refrigerator and "4" for freezer.  
You can adjust the Refrigerator and the Freezer control temperature by pressing the ADJUST button.
2. When the power is restored after a power failure, it is automatically set to last setting selected.

\*Note: To ERROR CODE on display panel refer to page 50.



### 9-1-2 Control of freezer fan motor

1. Freezer fan motor has high and standard RPMs.
2. High RPM is used when electricity is first on, for ULTRA ICE, and when refrigerator is overloaded.  
But standard RPM is used for general purposes.
3. To improve cooling speed and load corresponding speed, the RPM of freezer fan motor shall change from normal speed to high speed.
4. High speed (2500RPM) : Initial power on or load corresponding operation, ULTRA ICE.  
Normal speed (2200 RPM): general working conditions.
5. Fan motor stops when refrigerator or freezer door opens.

### 9-1-3 ULTRA ICE

1. The purpose of this function is to intensify the cooling speed of freezer and to increase the amount of ice.
2. Whenever selection switch is pressed, selection/release, the LED will turn ON or OFF.
3. If there is a power cut and the refrigerator is power on again, ULTRA ICE function will be canceled.
4. To activate these function you need to press the ULTRA ICE key and the LED will turn ON. This function will remain activated for 24 hrs. The first three hours the compressor and ULTRA ICE will be ON. The next 21 hours the freezer will be controlled at the lowest temperature. After 24 hours or if the ULTRA ICE key is pressed again, the freezer will return to its previous temperature.
5. For the first three hours notice the following cases:
  - (1) Compressor and freezer fan(HIGH RPM) continuously operate for three hours.
  - (2) If defrost starts during ULTRA ICE, ULTRA ICE operates for the rest of time after defrost is completed, when ULTRA ICE operation time is less than 90 minutes.  
If ULTRA ICE operates for more than 90minutes, the ULTRA ICE will operate for two hours after defrost is completed.
  - (3) If ULTRA ICE is pressed during defrost, ULTRA ICE LED is on but this function will start seven minutes after defrost is completed and it shall operate for three hours.
  - (4) If ULTRA ICE is selected within seven minutes after compressor has stopped, the compressor (compressor delays seven minutes) shall start after the balance of the delay time.
  - (5) The fan motor in the freezer compartment rotates at high speed during ULTRA ICE.
6. For the rest of 21 hours, the freezer will be controlled at the lowest temperature.

### 9-1-4 Refrigerator Lamp Auto Off

1. To protect the risk of lamp heat, when Refrigerator door opens for 7 min, refrigerator lamp is auto off.

### 9-1-5 Alarm for Open Door

1. This feature sounds a buzzer when the freezer or refrigerator door is not closed within 1 minute after it is opened.
2. One minute after the door is opened, the buzzer sounds three times each for 1/2 seconds. These tones repeat every 30 seconds.
3. The alarm is cancelled when the freezer or the refrigerator is closed while the buzzer sounds.

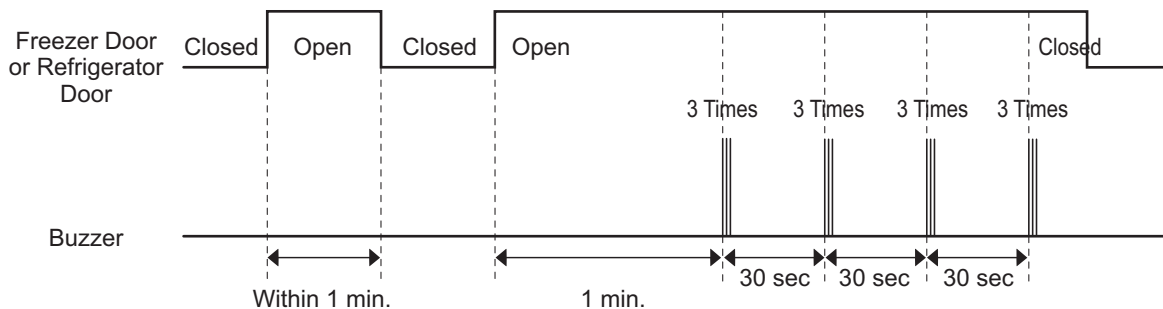

### 9-1-6 Buzzer Sound

When the button on the front Display is pushed, a Ding~ Dong~ sound is produced.

### 9-1-7 Defrosting (removing frost)

1. Defrosting starts each time the COMPRESSOR running time reaches 7 hours.
2. For initial power on or for restoring power, defrosting starts when the compressor running time reaches 4 hours.
3. Defrosting stops if the sensor temperature reaches 46.4°F(8°C) or more. If the sensor doesn't reach 46.4°F(8°C) in 2 hours, the defrost mode is malfunctioning. (Refer to the defect diagnosis function, 8-1-9.)
4. Defrosting won't function if its sensor is defective (wires are cut or short circuited)

### 9-1-8 Electrical Parts Are Turned On Sequentially

Electrical parts such as COMP, defrosting heater, freezer FAN, etc. are turned on in the following order to prevent noise and parts damage. Several parts are started at the same time at initial power on and are turned off together when TEST is completed.

OPERATING		ORDERS				
Initial power on	Temperature of Defrosting Sensor is 45°C or more (when unit is newly purchased or when moved)	<b>POWER ON</b>	in 1/2 second →	<b>COMP ON</b>	in 1/2 second →	<b>Freezer FAN ON</b>
	Temperature of defrosting sensor is lower than 45°C (when power cuts, SERVICE)	<b>POWER ON</b>	in 1/2 second →	<b>Defrosting heater ON</b>	in 10 second →	<b>Defrosting heater OFF</b>
		in 1/2 second →	<b>COMP ON</b>	in 1/2 second →	<b>Freezer FAN ON</b>	
	Reset to normal operation from TEST MODE	<b>Total load OFF</b>	in 7 minute →	<b>COMP ON</b>	in 1/2 second →	<b>Freezer FAN ON</b>

### 9-1-9 Defect Diagnosis Function

1. Automatic diagnosis makes servicing the refrigerator easy.
2. When a defect occurs, the buttons will not operate; but the tones, such as ding, will sound.
3. When the defect CODE removes the sign, it returns to normal operation (RESET).
4. The defect CODE shows on the Refrigerator and Freezer Display.



**ERROR CODE on display panel**      ● LED OFFLED ON    ○

No.	ITEM		ERROR INDICATION	CONTENTS	REMARKS
1	Failure of Freezer Sensor	All Off	● ○ ○ ○ ○ ○ ○ ○	Cut or short circuited wire	Inspect Connecting Wires on each sensor
2	Failure of Refrigerator Sensor	All Off	○ ● ○ ○ ○ ○ ○ ○	Cut or short circuited wire	
3	Failure of Defrost Sensor	All Off	○ ○ ● ○ ○ ○ ○ ○	Cut or short circuited wire	
4	Failure of Defrost Mode	All Off	● ● ● ● ○ ○ ○ ○	When defrost sensor does not reach 8°C within 1 hour after starting defrost	Snapping of defrost heater or temperature fuse, pullout of connector (indicated minimum 2h after failure occurs)
5	Failure of BLDC fan motor at freezing compartment	All Off	● ● ● ● ● ○ ○ ○	If there is no fan motor signal for more than 115s in operation fan motor	Poor motor, hooking to wires of fan, contact of structures to fan, snapping or short circuit of Lead wires.
6	Failure of Icemaker Kit	All Off	○ ○ ○ ○ ● ○ ○ ○	Failure of wires such as motor in I/M KIT, GEAR, HALL IC.	When the ice ejecting does not operate on pressing the I/M TEST S/W
7	Failure of Icemaker Sensor	All Off	○ ○ ○ ○ ○ ● ○ ○	Snapping or short circuit of ice making sensor.	Connecting Wire Test On Sensor

**Primary Error:** F sensor, R1 sensor, D sensor, defrost errors, F-FAN errors.

**Secondary Error:** I / M sensors, I / M Kit

When an error occurs the first 3 hours the Primary Error and Secondary Error is indicated in the display check mode (Pressing refrigerator and freezer temperature control button at the same time more than one second). After the 3 hours and if the error is still present the Primary Error will show in the display automatically (See Note 1) and the Secondary Error is indicated in the display check mode.

Note1: In the Primary Error after 3 hours of the error occurs all display lights turn OFF except the Freezer Temperature (Trouble Code Index) indicating the failure mode.

\*LED check function: When there's no error, when the refrigerator temperature control and the freezer temperature control button at the same time are held for 1 second or longer, every LED on the display turns on at the same time when the buttons are released, the previous mode is restored.

## 9-1-10 TEST Mode

1. The Test mode allows checking the PCB and the function of the product as well as finding out the defective part in case of an error.
2. The test mode is operated by pressing two buttons at Display panel.
3. While in the test mode, the function control button is not recognized, but the recognition tone (beep~) sounds.
4. After exiting the test mode, be sure to reset by unplugging and then plugging in the appliance.
5. If an error, such as a sensor failure, is detected while in the test mode, the test mode is cleared and the error code is displayed.
6. While an error code is displayed, the test mode will not be activated.

MODE	MANIPULATION	CONTENTS	REMARKS
TEST1	Push ULTRA ICE key and ADJUST key of Freezer Temperature at the same time over 3s. Or Push TEST switch (on the main Board) once.  <Cooling MODE>	1. Continuous operation of the compressor and the freezer fan. 2. Stepping Damper OPEN 3. Defrosting Heater OFF 4. Display LED all ON	Maximum test time: 5 minutes.
TEST2	Push ULTRA ICE key and ADJUST key of Freezer Temperature at the same time over 3 seconds in TEST MODE 1 Or Push TEST switch once In TEST MODE 1. <Forced desfrosting MODE>	1. Compressor and the freezer fan OFF 2. Stepping Damper CLOSE 3. Defrosting heater ON 4. Display LED 1, 3, 5, 7 ON	Maximum test time: 2 hours Reset if the temperature of the defrosting sensor is 8°C (46°F) or more.
Reset to Normal	Push ULTRA ICE key and ADJUST key of Freezer Temp. at the same time over 3 seconds. in TEST MODE 2	Reset to initial status (COMP 7 min delay)	

### \* Freezer Fan RPM Variable Check:

In case the freezer fan is in operation when the ADJUST key in Refrigerator and Freezer Temp. Control are pressed for more than one second at the same time freezer fan RPM changes. (for example if high speed, to normal speed or if normal speed, to high speed for 30 seconds)  
 After 30 seconds, it turns to its original RPM.

### \* Demonstration MODE:

1. When the ULTRA ICE key and ADJUST key of refrigerator temperature control are pressed for more than 3 seconds at the same time temperature's it converts to demonstration mode.
2. In this status, each LED is rotated with 1 second interval.
3. In this status, all Loads are off (Compressor / Fan / Damper / Heater)  
 (Even is Demonstration Mode, the refrigerator Lamp automatic off function works normally and can be demonstrated)
4. It reset if you do again as clause.

# 9-2 PCB FUNCTION

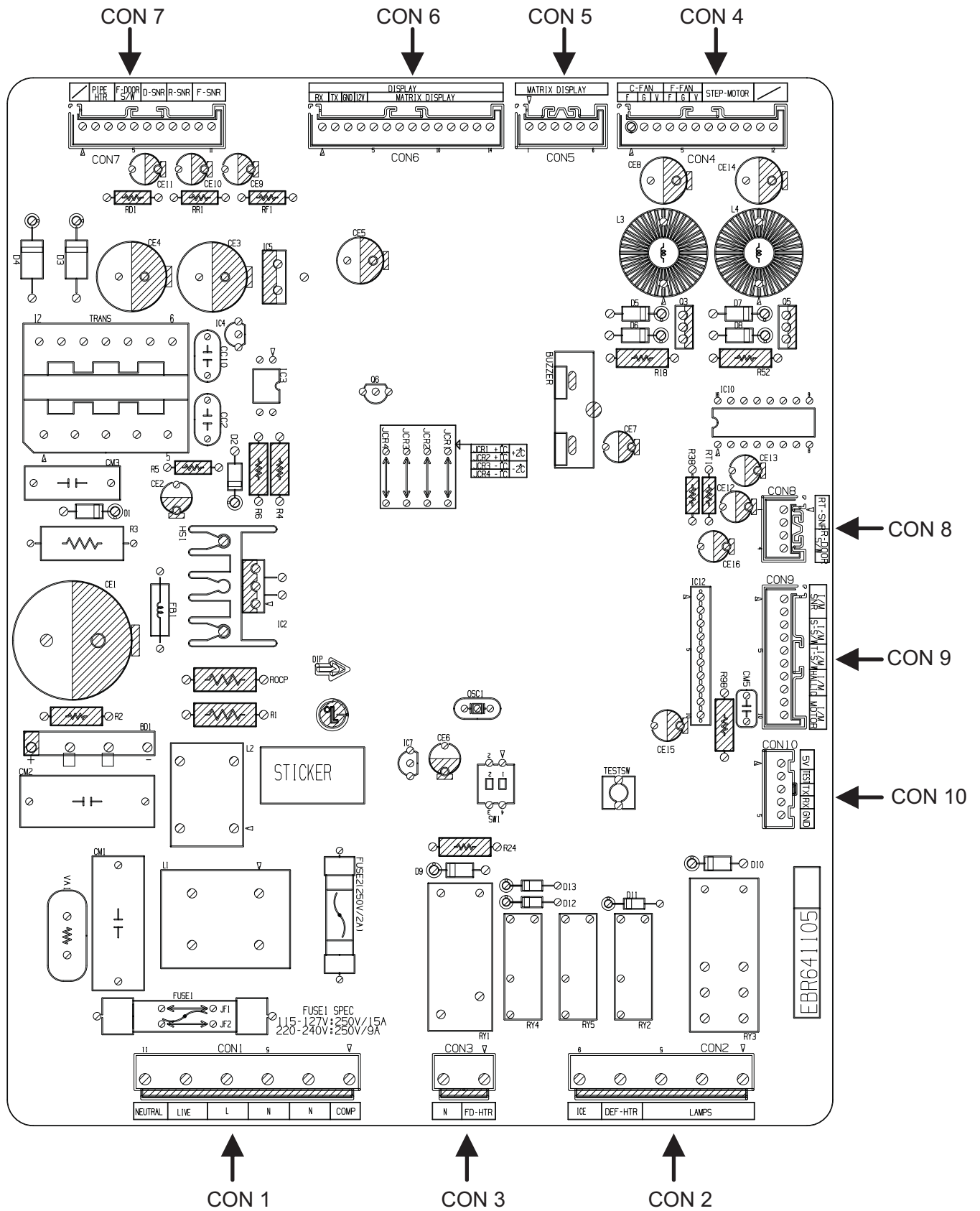

## 9-2-1 Power Circuit

Power is supplied to the control board at the pin 11 and 9 of connector #1. (Refer to figure 1)

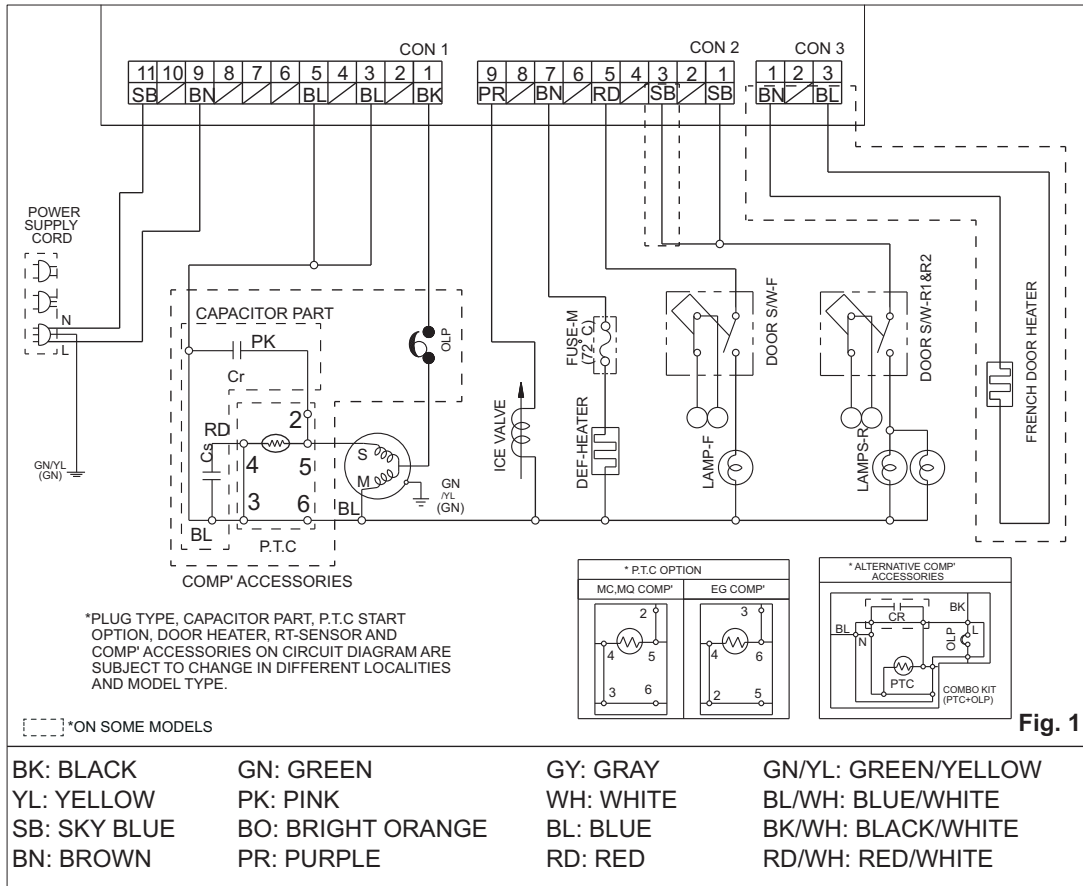

## 9-2-2. Load and Door Light Circuit (HV)

### 1. Load Drive Condition Check

To measure outputs of the control board, check voltages between the pins for the following components: (Refer to Fig. 1).

Circuit	Pin Number	Pin Number	Output Voltage
Compressor	Con 1 Pin 1	Con 1 Pin 3	115 VAC
Defrost Heater	Con 2 Pin 7	Con 1 Pin 3	115 VAC
F Lamp	Con 2 Pin 5	Con 1 Pin 3	115 VAC
R Lamp	Con 2 Pin 1 and/or 3	Con 1 Pin 3	115 VAC
Ice Maker	Con 2 Pin 9	Con 1 Pin 3	115 VAC

Connector 1				
Pin	11	9	3	1
	N	L	N	COMP

Connector 2					
Pin	9	7	5	3	1
	Ice Valve	Def Heater	F Lamp	R Lamp	

NOTE: When the door of the refrigerator is left open for 7 minutes or longer, the lamp of the refrigerator turns off automatically.

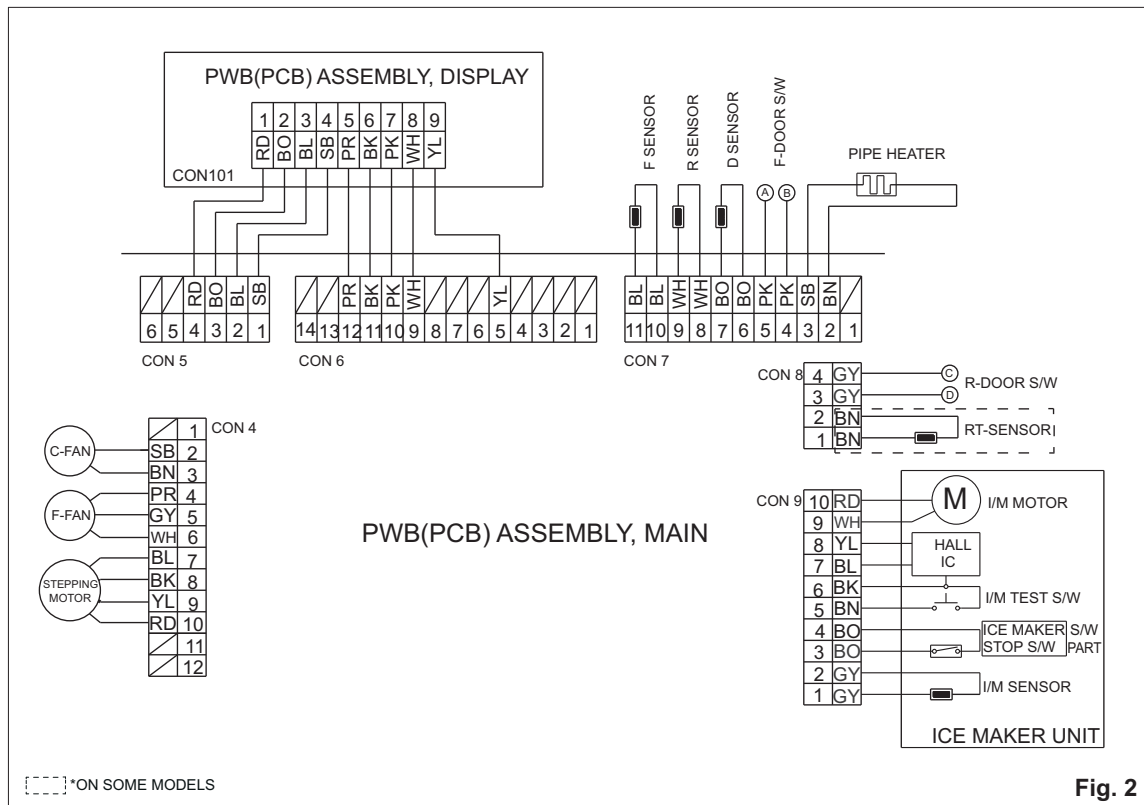

## 2. Door Monitor Circuit (LV)

Refrigerator	Pin Number	Pin Number	Voltage
F Door Close	Con 7 Pin 4	Con 7 Pin 5	5 Volts
F Door Open	Con 7 Pin 4	Con 7 Pin 5	0 Volts
R Door Close	Con 8 Pin 3	Con 8 Pin 4	5 Volts
R Door Open	Con 8 Pin 3	Con 8 Pin 4	0 Volts

Connector 8				
Pin	4	3	2	1
	R-Door S/W	NC	NC	

### 9-2-3 Temperature Sensor Circuit (Refer to Figure 2)

Voltage supplied to each sensor will range between 0.5 volts -22°F(-30°C) and 4.5 volts 122°F(50°C) depending upon the temperature in the compartments. A measurement of 0 volts indicates a short in the sensor circuit. A measurement of 5 volts indicates an open in the sensor circuit.

Connector 7											
PIN	11	10	9	8	7	6	5	4	3	2	1
	F-Sensor		R-Sensor		D-Sensor		F-Door S/W		Pipe Heater		NC

To measure the outputs of the sensors, check the voltages between the pins as in the table. And refer the values in the section "RESISTANCE SPECIFICATION OF SENSOR"

Sensor	Pin Number	Pin Number
F- Sensor	Con 7 Pin 10	Con 7 Pin 11
R- Sensor	Con 7 Pin 8	Con 7 Pin 9
D- Sensor	Con 7 Pin 6	Con 7 Pin 7
I/M Sensor	Con 7 Pin 1	Con 9 Pin 2

To measure the outputs of the fans on the control boards check the voltages between the pins for the following components:

FAN	Pin Number	Pin Number	Output Voltage	
			Motor On	Motor Off
Freezer Fan	Con 4 Pin 5	Con 4 Pin 6	10-14Vdc	2Vdc or less
Cooling Fan	con 4 Pin 2	Con 4 Pin 3	10-14Vdc	2Vdc or less

Connector 4												
PIN	12	11	10	9	8	7	6	5	4	3	2	1
	NC		Stepping Motor				F-Fan			C-Fan		NC
	NC	NC					V	G	F	V	G	NC

#### 9-2-4 ICE MAKER

Connector 9										
PIN	10	9	8	7	6	5	4	3	2	1
	I/M Motor		Hall IC		I/M Test S/W		I/M Stop S/W		I/M Sensor	

Circuit	Pin Number	Pin Number	Output Voltage
I/M Stop S/W	Con 9 Pin 3	Con 9 Pin 4	0~5Vdc
I/M Test S/W	Con 9 Pin 5	Con 9 Pin 6	0~5Vdc

---

### 9-3 RESISTANCE SPECIFICATION OF SENSOR

TEMPERATURE DETECTED SENSOR	RESISTANCE OF FREEZER SENSOR	RESISTANCE OF REFRIGERATOR DEFROST SENSOR & ROOM SENSOR
-20°C	22.3 KΩ	77 KΩ
-15°C	16.9 KΩ	60 KΩ
-10°C	13.0 KΩ	47.3 KΩ
-5°C	10.1 KΩ	38.4 KΩ
0°C	7.8 KΩ	30 KΩ
+5°C	6.2 KΩ	24.1 KΩ
+10°C	4.9 KΩ	19.5 KΩ
+15°C	3.9 KΩ	15.9 KΩ
+20°C	3.1 KΩ	13 KΩ
+25°C	2.5 KΩ	11 KΩ
+30°C	2.0 KΩ	8.9 KΩ
+40°C	1.4 KΩ	6.2 KΩ
+50°C	0.8 KΩ	4.3 KΩ

- The resistance of the SENSOR has a  $\pm 5\%$  common difference.
- Measure the resistance of the SENSOR after leaving it for over 3 minutes in the measuring temperature. This delay is necessary due to sensor response speed.



---

## FREEZER PARTS

Caution: Use the part number to order part, not the position number.

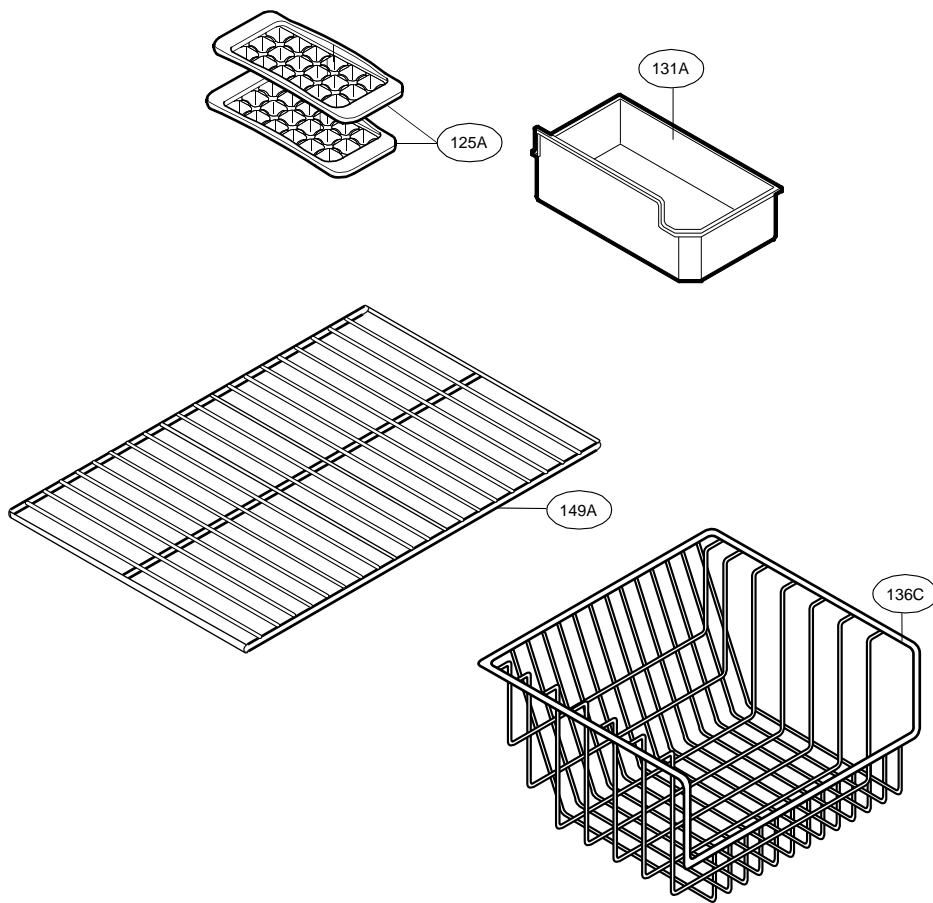

## REFRIGERATOR PARTS

Caution: Use the part number to order part, not the position number.

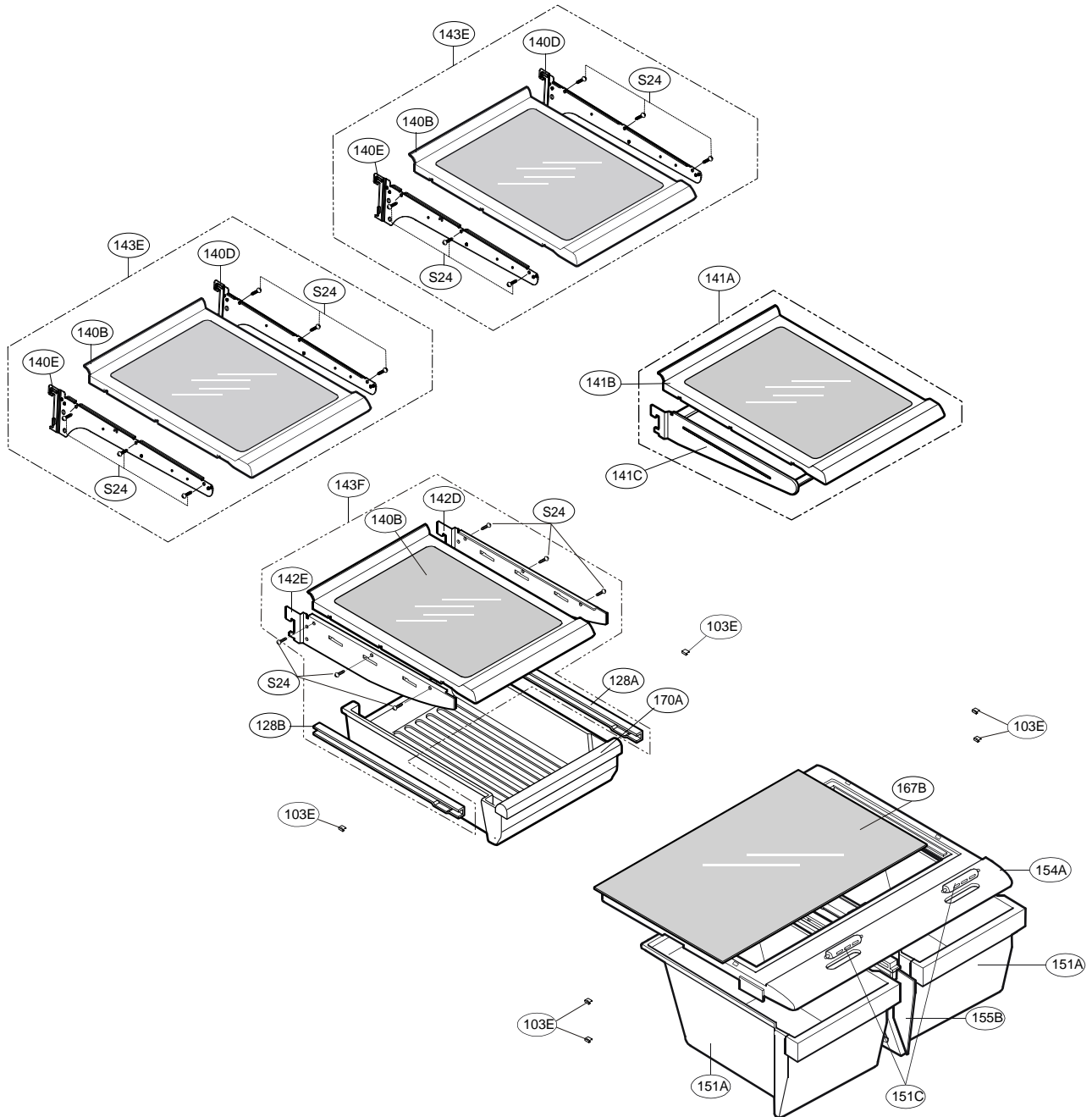

### DOOR PARTS

Caution: Use the part number to order part, not the position number.

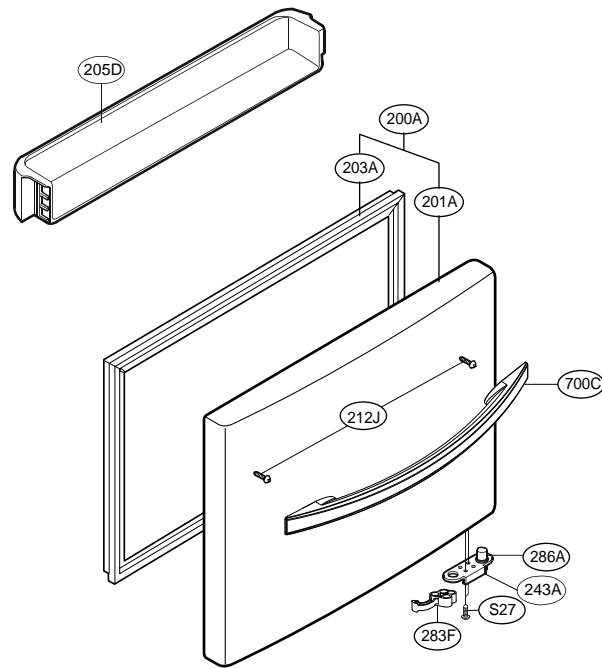
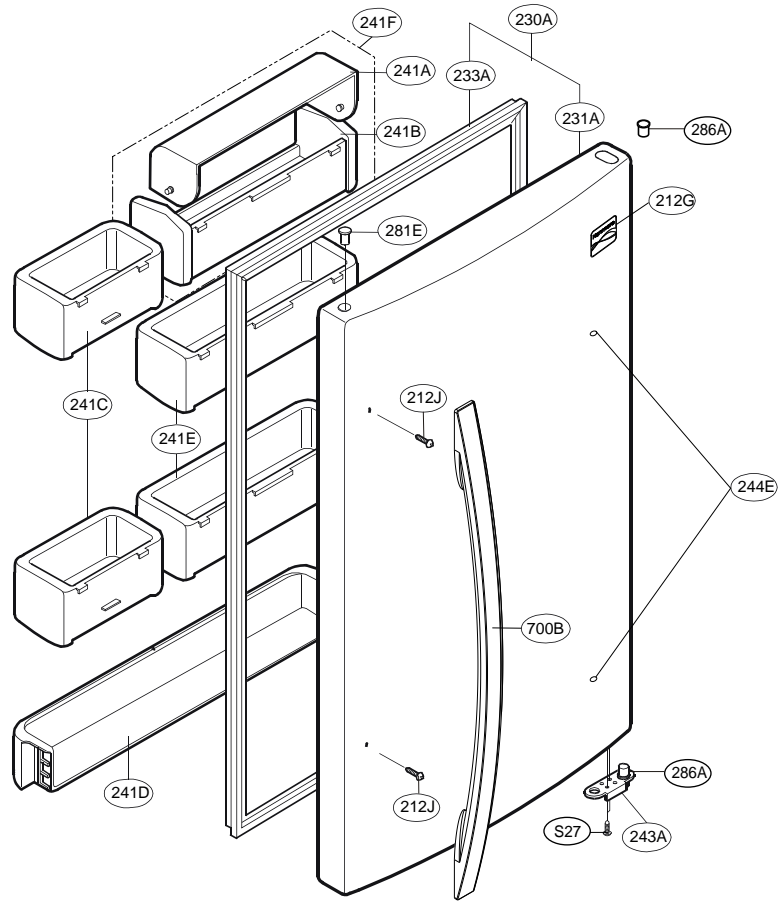

Loc No.	Part No.	Description	Loc No.	Part No.	Description
103A	3650JJ2003E	Handle,Rear	283D	4774JJ2002A	Hinge,Lower
103B	3650JJ2003A	Handle,Rear	283F	MJB36873201	Stopper,Door
103C	3550JJ0006A	Cover,Lower	284D	1STZJA3004K	Screw,Customized
103E	5218JJ3001A	Rail,Slide	286A	4984JJ3003A	Bush
105A	5251JA3003B	Tube Assembly,Drain	301A	5421JJ1001B	Evaporator Assembly
105F	5070JJ3002A	Skirt,Lower	304A	3551JJ2008B	Cover Assembly,Machinery(Rear)
106A	4779JA2003A	Leg Assembly,Adjust	305B	4580JJ3001A	Roller
106B	4J00382C	Washer,Common	305C	4J04238A	Pin,Common
120B	5209JJ1002A	Duct Assembly,Multi	307A	TCA32196201	Compressor,Set Assembly
125A	3390JJ1023A	Tray,Ice	307B	ACF67062306	Compressor Assembly
125D	4930JJ3007A	Holder,Bracket	308A	EBG32606502	Thermistor Assembly,PTC
128A	4975JJ2002A	Guide Assembly,Rail	309A	6750C-0005P	Overload Protect
128B	4975JJ2002B	Guide Assembly,Rail	310A	3550JA2042C	Cover,PTC
128E	4975JJ2009A	Guide Assembly,Rail	312A	5040JA3031A	Damper,Compressor
128F	4975JJ2009B	Guide Assembly,Rail	314A	4620JA3015A	Stopper,Compressor
131A	MKK61862301	Bucket,Ice	315A	3103JJ1001Z	Base Assembly,Compressor
135C	3550JJ2046A	Cover,Grille Fan	317A	5851JA2007E	Drier Assembly
136C	3390JJ1057B	Tray,Drawer	318A	4930JA3034A	Holder,Drier
140B	5027JJ1039C	Shelf Assembly,Refrigerator	319A	3390JJ0004A	Tray,Drip
140D	MHL38615403	Shelf,Net	319C	MEA41997401	Guide,Fan
140E	MHL38615404	Shelf,Net	319E	4810JJ2005A	Bracket,Motor
141A	5027JJ1014R	Shelf Assembly,Refrigerator	323B	5403JJ1007A	Condenser Assembly,Wire
141B	5027JJ1038B	Shelf Assembly,Refrigerator	327A	5006JA3034A	Cap,Drain Tube
141C	5027JJ2005U	Shelf Assembly,Net	328A	4J03020A	Damper,Pipe
142D	5026JJ2001L	Shelf,Net	329A	5901JJ1005A	Fan Assembly
142E	5026JJ2001M	Shelf,Net	329C	ADP36665702	Fan Assembly
143E	AHT72974102	Shelf Assembly,Refrigerator	332A	3531JJ1004D	Grille Assembly,Fan
143F	AHT72974107	Shelf Assembly,Refrigerator	401A	6615JB2005C	Controller Assembly
145A	4930JJ2003A	Holder,Shelf	404A	4681JB1027N	Motor,DC
145B	4930JJ2004A	Holder,Shelf	405A	4811JJ2002A	Bracket Assembly,Motor
149A	MHL61891901	Shelf,Freezer	405B	5040JJ2001A	Damper,Motor Support
151A	3391JJ1020C	Tray Assembly,Vegetable	405C	5040JA2009B	Damper,Motor Support
151C	4940JJ2003D	Knob,Shutter	405F	5040JA2004B	Damper,Motor Support
154A	MCK63206402	Cover,TV	405G	4811JJ2002K	Bracket Assembly,Motor
155B	4981JJ2001B	Supporter Assembly,Cover TV	406B	6600JB1010A	Switch,Push Button
158A	3550JJ1040A	Cover,Lamp	409B	6912JK2002C	Lamp,Incandescent
158E	MCK62661401	Cover,Lamp	409D	3034JJ1002B	Reflector,Lamp
167B	MHL61972602	Shelf,Glass	410A	6621JK2003B	Harness Assembly
170A	3391JJ2004H	Tray Assembly,Meat	410G	0CZZJB2012J	Capacitor,Electric Appliance Film,Box
200A	ADC73046208	Door Assembly,Freezer	411A	6411JK1006A	Power Cord Assembly
201A	ADD72976408	Door Foam Assembly,Freezer	412D	6877JK2011A	Harness Assembly
203A	4987JJ1004A	Gasket Assembly,Door	418A	5300JB1100J	Heater,Sheath
205D	5004JJ1040A	Basket,Door	419B	5200JJ3003E	Pipe,Joint
212G	MFT61866203	Name Plate	420A	4681JB1027P	Motor,DC
212J	4620JJ3007E	Stopper,Handle	501A	EBR64110502	PCB Assembly,Main
230A	ADC73026008	Door Assembly,Refrigerator	503C	6871JB2047A	PCB Assembly,Display
231A	ADD72977208	Door Foam Assembly,Refrigerator	503D	3110JJ1005A	Case,Display
233A	4987JJ1004B	Gasket Assembly,Door	503E	3550JJ2031A	Cover,Display
241A	3550JJ1015B	Cover,Tray	503F	ABQ33905318	Case Assembly,Display
241B	5004JJ1021B	Basket,Door	503G	MCR62352701	Decor,Control
241C	5004JJ1031A	Basket,Door	610A	3550JJ2020A	Cover,Sensor
241D	5004JJ0001A	Basket,Door	619B	3550JJ2024A	Cover,Valve
241E	5004JJ1029A	Basket,Door	623H	MCK62967601	Cover,Tube
241F	5005JJ2010E	Basket Assembly,Door	700B	AED72912504	Handle Assembly,Refrigerator
243A	4620JJ3006A	Stopper,Door	700C	AED72952903	Handle Assembly,Freezer
244E	5006JJ3016A	Cap,Handle	903D	6500JK1003A	Sensor,Temperature
281A	3550JJ2013A	Cover,Hinge	903E	6500JK1004A	Sensor,Temperature
281B	4775JJ2003B	Hinge Assembly,Upper	B01	1STZJA3004F	Screw,Customized
281E	5006JJ3014A	Cap,Hinge	LE	MEZ62592102	Label,Energy
282B	4775JJ8002F	Hinge Assembly,Center	OM	MFL63283801	Manual,Owners
282C	1PZZJJ3002F	Pin,Common	S01	1SZZJJ3010A	Screw,Customized
282E	5006JJ2001A	Cap,Hinge	S24	1SZZJA3011B	Screw,Customized
282F	3806JL2006L	Decor,Duct	S27	4J01424C	Screw,Customized
282H	5006JJ3004A	Cap,Hinge	S38	4J00415D	Screw,Customized
283B	4775JJ2007B	Hinge Assembly,Lower	TS	MBM62277104	Card,Instruction

Loc No.	Part No.	Description	Loc No.	Part No.	Description
103A	3650JJ2003F	Handle,Rear	283D	4774JJ2002A	Hinge,Lower
103B	3650JJ2003B	Handle,Rear	283F	MJB36873201	Stopper,Door
103C	3550JJ0006B	Cover,Lower	284D	1STZJA3004K	Screw,Customized
103E	5218JJ3001A	Rail,Slide	286A	4984JJ3003A	Bush
105A	5251JA3003B	Tube Assembly,Drain	301A	5421JJ1001B	Evaporator Assembly
105F	5070JJ3002A	Skirt,Lower	304A	3551JJ2008B	Cover Assembly,Machinery(Rear)
106A	4779JA2003A	Leg Assembly,Adjust	305B	4580JJ3001A	Roller
106B	4J00382C	Washer,Common	305C	4J04238A	Pin,Common
120B	5209JJ1002A	Duct Assembly,Multi	307A	TCA32196201	Compressor,Set Assembly
125A	3390JJ1023A	Tray,Ice	307B	ACF67062306	Compressor Assembly
125D	4930JJ3007A	Holder,Bracket	308A	EBG32606502	Thermistor Assembly,PTC
128A	4975JJ2002A	Guide Assembly,Rail	309A	6750C-0005P	Overload Protect
128B	4975JJ2002B	Guide Assembly,Rail	310A	3550JA2042C	Cover,PTC
128E	4975JJ2009A	Guide Assembly,Rail	312A	5040JA3031A	Damper,Compressor
128F	4975JJ2009B	Guide Assembly,Rail	314A	4620JA3015A	Stopper,Compressor
131A	MKK61862301	Bucket,Ice	315A	3103JJ1001Z	Base Assembly,Compressor
135C	3550JJ2046A	Cover,Grille Fan	317A	5851JA2007E	Drier Assembly
136C	3390JJ1057B	Tray,Drawer	318A	4930JA3034A	Holder,Drier
140B	5027JJ1039C	Shelf Assembly,Refrigerator	319A	3390JJ0004A	Tray,Drip
140D	MHL38615403	Shelf,Net	319C	MEA41997401	Guide,Fan
140E	MHL38615404	Shelf,Net	319E	4810JJ2005A	Bracket,Motor
141A	5027JJ1014R	Shelf Assembly,Refrigerator	323B	5403JJ1007A	Condenser Assembly,Wire
141B	5027JJ1038B	Shelf Assembly,Refrigerator	327A	5006JA3034A	Cap,Drain Tube
141C	5027JJ2005U	Shelf Assembly,Net	328A	4J03020A	Damper,Pipe
142D	5026JJ2001L	Shelf,Net	329A	5901JJ1005A	Fan Assembly
142E	5026JJ2001M	Shelf,Net	329C	ADP36665702	Fan Assembly
143E	AHT72974102	Shelf Assembly,Refrigerator	332A	3531JJ1004D	Grille Assembly,Fan
143F	AHT72974107	Shelf Assembly,Refrigerator	401A	6615JB2005C	Controller Assembly
145A	4930JJ2003A	Holder,Shelf	404A	4681JB1027N	Motor,DC
145B	4930JJ2004A	Holder,Shelf	405A	4811JJ2002A	Bracket Assembly,Motor
149A	MHL61891901	Shelf,Freezer	405B	5040JJ2001A	Damper,Motor Support
151A	3391JJ1020C	Tray Assembly,Vegetable	405C	5040JA2009B	Damper,Motor Support
151C	4940JJ2003D	Knob,Shutter	405F	5040JA2004B	Damper,Motor Support
154A	MCK63206402	Cover,TV	405G	4811JJ2002K	Bracket Assembly,Motor
155B	4981JJ2001B	Supporter Assembly,Cover TV	406B	6600JB1010A	Switch,Push Button
158A	3550JJ1040A	Cover,Lamp	409B	6912JK2002C	Lamp,Incandescent
158E	MCK62661401	Cover,Lamp	409D	3034JJ1002B	Reflector,Lamp
167B	MHL61972602	Shelf,Glass	410A	6621JK2003B	Harness Assembly
170A	3391JJ2004H	Tray Assembly,Meat	410G	0CZZJB2012J	Capacitor,Electric Appliance Film,Box
200A	ADC73046209	Door Assembly,Freezer	411A	6411JK1006A	Power Cord Assembly
201A	ADD72976409	Door Foam Assembly,Freezer	412D	6877JK2011A	Harness Assembly
203A	4987JJ1004A	Gasket Assembly,Door	418A	5300JB1100J	Heater,Sheath
205D	5004JJ1040A	Basket,Door	419B	5200JJ3003E	Pipe,Joint
212G	MFT61866204	Name Plate	420A	4681JB1027P	Motor,DC
212J	4620JJ3007E	Stopper,Handle	501A	EBR64110502	PCB Assembly,Main
230A	ADC73026009	Door Assembly,Refrigerator	503C	6871JB2047A	PCB Assembly,Display
231A	ADD72977209	Door Foam Assembly,Refrigerator	503D	3110JJ1005A	Case,Display
233A	4987JJ1004B	Gasket Assembly,Door	503E	3550JJ2031A	Cover,Display
241A	3550JJ1015B	Cover,Tray	503F	ABQ33905318	Case Assembly,Display
241B	5004JJ1021B	Basket,Door	503G	MCR62352701	Decor,Control
241C	5004JJ1031A	Basket,Door	610A	3550JJ2020A	Cover,Sensor
241D	5004JJ0001A	Basket,Door	619B	3550JJ2024A	Cover,Valve
241E	5004JJ1029A	Basket,Door	623H	MCK62967601	Cover,Tube
241F	5005JJ2010E	Basket Assembly,Door	700B	AED72912506	Handle Assembly,Refrigerator
243A	4620JJ3006B	Stopper,Door	700C	AED72952904	Handle Assembly,Freezer
244E	5006JJ3016B	Cap,Handle	903D	6500JK1003A	Sensor,Temperature
281A	3550JJ2013B	Cover,Hinge	903E	6500JK1004A	Sensor,Temperature
281B	4775JJ2003B	Hinge Assembly,Upper	B01	1STZJA3004F	Screw,Customized
281E	5006JJ3014B	Cap,Hinge	LE	MEZ62592102	Label,Energy
282B	4775JJ8002D	Hinge Assembly,Center	OM	MFL63283801	Manual,Owners
282C	1PZZJJ3002F	Pin,Common	S01	1SZZJJ3010A	Screw,Customized
282E	5006JJ2001E	Cap,Hinge	S24	1SZZJA3011B	Screw,Customized
282F	3806JL2006L	Decor,Duct	S27	4J01424C	Screw,Customized
282H	5006JJ3004D	Cap,Hinge	S38	4J00415D	Screw,Customized
283B	4775JJ2007B	Hinge Assembly,Lower	TS	MBM62277104	Card,Instruction

Loc No.	Part No.	Description	Loc No.	Part No.	Description
103A	3650JJ2003M	Handle,Rear	283B	4775JJ2007B	Hinge Assembly,Lower
103B	3650JJ2003L	Handle,Rear	283D	4774JJ2002A	Hinge,Lower
103C	3550JJ0006C	Cover,Lower	283F	MJB36873201	Stopper,Door
103E	5218JJ3001A	Rail,Slide	284D	1STZJA3004K	Screw,Customized
105A	5251JA3003B	Tube Assembly,Drain	286A	4984JJ3003A	Bush
105F	5070JJ3002A	Skirt,Lower	301A	5421JJ1001B	Evaporator Assembly
106A	4779JA2003A	Leg Assembly,Adjust	304A	3551JJ2008B	Cover Assembly,Machinery(Rear)
106B	4J00382C	Washer,Common	305B	4580JJ3001A	Roller
120B	5209JJ1002A	Duct Assembly,Multi	305C	4J04238A	Pin,Common
125A	3390JJ1023A	Tray,Ice	307A	TCA32196201	Compressor,Set Assembly
125D	4930JJ3007A	Holder,Bracket	307B	ACF67062306	Compressor Assembly
128A	4975JJ2002A	Guide Assembly,Rail	308A	EBG32606502	Thermistor Assembly,PTC
128B	4975JJ2002B	Guide Assembly,Rail	309A	6750C-0005P	Overload Protect
128E	4975JJ2009A	Guide Assembly,Rail	310A	3550JA2042C	Cover,PTC
128F	4975JJ2009B	Guide Assembly,Rail	312A	5040JA3031A	Damper,Compressor
131A	MKK61862301	Bucket,Ice	314A	4620JA3015A	Stopper,Compressor
135C	3550JJ2046A	Cover,Grille Fan	315A	3103JJ1001Z	Base Assembly,Compressor
136C	3390JJ1057B	Tray,Drawer	317A	5851JA2007E	Drier Assembly
140B	5027JJ1039C	Shelf Assembly,Refrigerator	318A	4930JA3034A	Holder,Drier
140D	MHL38615403	Shelf,Net	319A	3390JJ0004A	Tray,Drip
140E	MHL38615404	Shelf,Net	319C	MEA41997401	Guide,Fan
141A	5027JJ1014R	Shelf Assembly,Refrigerator	319E	4810JJ2005A	Bracket,Motor
141B	5027JJ1038B	Shelf Assembly,Refrigerator	323B	5403JJ1007A	Condenser Assembly,Wire
141C	5027JJ2005U	Shelf Assembly,Net	327A	5006JA3034A	Cap,Drain Tube
142D	5026JJ2001L	Shelf,Net	328A	4J03020A	Damper,Pipe
142E	5026JJ2001M	Shelf,Net	329A	5901JJ1005A	Fan Assembly
143E	AHT72974102	Shelf Assembly,Refrigerator	329C	ADP36665702	Fan Assembly
143F	AHT72974107	Shelf Assembly,Refrigerator	332A	3531JJ1004D	Grille Assembly,Fan
145A	4930JJ2003A	Holder,Shelf	401A	6615JB2005C	Controller Assembly
145B	4930JJ2004A	Holder,Shelf	404A	4681JB1027N	Motor,DC
149A	MHL61891901	Shelf,Freezer	405A	4811JJ2002A	Bracket Assembly,Motor
151A	3391JJ1020C	Tray Assembly,Vegetable	405B	5040JJ2001A	Damper,Motor Support
151C	4940JJ2003D	Knob,Shutter	405C	5040JA2009B	Damper,Motor Support
154A	MCK63206402	Cover,TV	405F	5040JA2004B	Damper,Motor Support
155B	4981JJ2001B	Supporter Assembly,Cover TV	405G	4811JJ2002K	Bracket Assembly,Motor
158A	3550JJ1040A	Cover,Lamp	406B	6600JB1010A	Switch,Push Button
158E	MCK62661401	Cover,Lamp	409B	6912JK2002C	Lamp,Incandescent
167B	MHL61972602	Shelf,Glass	409D	3034JJ1002B	Reflector,Lamp
170A	3391JJ2004H	Tray Assembly,Meat	410A	6621JK2003B	Harness Assembly
200A	ADC73046210	Door Assembly,Freezer	410G	0CZZJB2012J	Capacitor,Electric Appliance Film,Box
201A	ADD72976410	Door Foam Assembly,Freezer	411A	6411JK1006A	Power Cord Assembly
203A	ADX52752609	Gasket Assembly,Door	412D	6877JK2011A	Harness Assembly
205D	5004JJ1040A	Basket,Door	418A	5300JB1100J	Heater,Sheath
212G	MFT61866206	Name Plate	419B	5200JJ3003E	Pipe,Joint
212J	4620JJ3007E	Stopper,Handle	420A	4681JB1027P	Motor,DC
230A	ADC73026010	Door Assembly,Refrigerator	503C	6871JB2047A	PCB Assembly,Display
231A	ADD72977210	Door Foam Assembly,Refrigerator	503D	3110JJ1005A	Case,Display
233A	4987JJ1004F	Gasket Assembly,Door	503E	3550JJ2031A	Cover,Display
241A	3550JJ1015B	Cover,Tray	503F	ABQ33905318	Case Assembly,Display
241B	5004JJ1021B	Basket,Door	503G	MCR62352701	Decor,Control
241C	5004JJ1031A	Basket,Door	610A	3550JJ2020A	Cover,Sensor
241D	5004JJ0001A	Basket,Door	619B	3550JJ2024A	Cover,Valve
241E	5004JJ1029A	Basket,Door	623H	MCK62967601	Cover,Tube
241F	5005JJ2010E	Basket Assembly,Door	700B	AED72912505	Handle Assembly,Refrigerator
243A	4620JJ3006C	Stopper,Door	700C	AED72952902	Handle Assembly,Freezer
244E	5006JJ3016C	Cap,Handle	903D	6500JK1003A	Sensor,Temperature
244E	5006JJ3016C	Cap,Handle	903E	6500JK1004A	Sensor,Temperature
281A	3550JJ2013C	Cover,Hinge	B01	1STZJA3004F	Screw,Customized
281B	4775JJ2003B	Hinge Assembly,Upper	LE	MEZ62592102	Label,Energy
281E	5006JJ3014C	Cap,Hinge	OM	MFL63283801	Manual,Owners
282B	4775JJ8002E	Hinge Assembly,Center	S01	1SZZJJ3010A	Screw,Customized
282C	1PZZJJ3002F	Pin,Common	S24	1SZZJA3011B	Screw,Customized
282E	5006JJ2001F	Cap,Hinge	S27	4J01424C	Screw,Customized
282F	3806JL2006L	Decor,Duct	S38	4J00415D	Screw,Customized
282H	5006JJ3004E	Cap,Hinge	TS	MBM62277104	Card,Instruction

# Get it fixed, at your home or ours!

## Your Home

For expert troubleshooting and home solutions advice:

**manage my home**

[www.managemyhome.com](http://www.managemyhome.com)

---

For repair – **in your home** – of **all** major brand appliances, lawn and garden equipment, or heating and cooling systems, **no matter who made it, no matter who sold it!**

For the replacement parts, accessories and owner's manuals that you need to do-it-yourself.

For Sears professional installation of home appliances and items like garage door openers and water heaters.

**1-800-4-MY-HOME<sup>®</sup>** Call anytime, day or night  
(1-800-469-4663) (U.S.A. and Canada)  
[www.sears.com](http://www.sears.com) [www.sears.ca](http://www.sears.ca)

---

## Our Home

For repair of carry-in items like vacuums, lawn equipment, and electronics, call anytime for the location of the nearest **Sears Parts & Repair Service Center**

**1-800-488-1222** (U.S.A.) **1-800-469-4663** (Canada)  
[www.sears.com](http://www.sears.com) [www.sears.ca](http://www.sears.ca)

---

To purchase a protection agreement on a product serviced by Sears:

**1-800-827-6655** (U.S.A.) **1-800-361-6665** (Canada)

---

Para pedir servicio de reparación a domicilio, y para ordenar piezas:

**1-888-SU-HOGAR<sup>®</sup>**  
(1-888-784-6427)

Au Canada pour service en français:

**1-800-LE-FOYER<sup>MC</sup>**  
(1-800-533-6937)  
[www.sears.ca](http://www.sears.ca)

# Sears

© Sears Brands, LLC

® Registered Trademark / <sup>TM</sup> Trademark / <sup>SM</sup> Service Mark of Sears Brands, LLC

® Marca Registrada / <sup>TM</sup> Marca de Fábrica / <sup>SM</sup> Marca de Servicio de Sears Brands, LLC

<sup>MC</sup> Marque de commerce / <sup>MD</sup> Marque déposée de Sears Brands, LLC

MFL62078207