



BOTTOM FREEZER REFRIGERATOR

REFRIGERATOR SERVICE MANUAL

CAUTION

BEFORE SERVICING THE PRODUCT

READ THE SAFETY PRECAUTIONS IN THIS MANUAL.

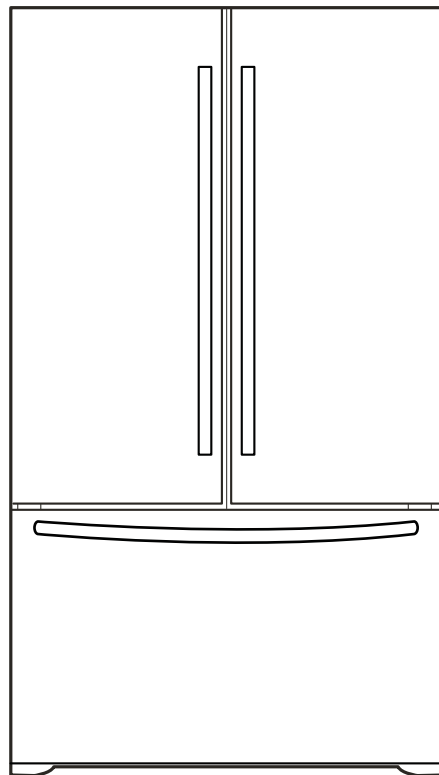

MODELS:

795.71303.010

795.71306.010

795.71302.010

795.71309.010

795.71304.010

CONTENTS

SAFETY PRECAUTIONS	3
1. SPECIFICATIONS	4
2. PARTS IDENTIFICATION	6
3. DISASSEMBLY	6
3-1 Fan and Fan Motor.....	7
3-2 Defrost Control Assembly.....	7
3-3 Lamp.....	7
3-4 Control Box Refrigerator.....	8
3-5 Multiduct.....	8
3-6 Door Disassembly for.....	9
3-6-1 Remove Refrigerator Door.....	9
3-6-2 Replace Refrigerator Door.....	9
3-6-3 Pull out Drawer.....	10
3-6-4 How to Remove Door Handles.....	12
3-7 Leveling and Door Alignment.....	13
4. ADJUSTMENT	14
4-1 Compressor	15
4-2 PTC-Starter	15
4-3 OLP (overload protector)	15
5. CIRCUIT DIAGRAM	16
6. TROUBLESHOOTING	17
6-1 Compressor and electric components	18
6-2 PTC and OLP	18
6-3 Other electrical components	19
6-4 Service diagnosis chart	20
6-5 Refrigeration cycle	21
7. OPERATION PRINCIPLE AND REPAIR METHOD OF ICEMAKER	23
7.1 Operation principle	23
7.2 Ice maker functions	24
8. CIRCUIT OF MICOM	27
8.1 Function	27
8.2 PCB function	31
8.3 Resistance specification of sensor	35
9. EXPLODED VIEW AND REPLACEMENT PART LIST	36

SAFETY PRECAUTIONS

Please read the following instructions before servicing your refrigerator.

1. Check the refrigerator for current leakage.
2. To prevent electric shock, unplug before servicing.
3. Always check line voltage and amperage.
4. Use standard electrical components.
5. Don't touch metal products in the freezer with wet hands. This may cause frost bite.
6. Prevent water from spilling on to electric elements or the machine parts.
7. Before tilting the refrigerator, remove all materials from on or in the refrigerator.
8. When servicing the evaporator, wear gloves to prevent injuries from the sharp evaporator fins.
9. Service on the refrigerator should be performed by a qualified technician. Sealed system repair must be performed by a CFC certified technician.

1. SPECIFICATIONS

1-1. DISCONNECT POWER CORD BEFORE SERVICING

IMPORTANT: Reconnect all grounding devices.

All parts of this appliance capable of conducting electrical current are grounded. If grounding wires, screws, straps, clips, nuts or washers used to complete a path to ground are removed for service, they must be returned to their original position and properly fastened.

1-2. IMPORTANT NOTICE

This information is intended for use by individuals possessing adequate background of electrical, electronic and mechanical experience.

Any attempt to repair a major appliance may result in personal injury and property damage. The manufacturer or seller cannot be responsible for the interpretation of this information, nor can it assume any liability in connection with its use.

1-3. ELECTRICAL SPECIFICATIONS

Freezer temperature control (Middle setting).....	-6°F to +8°F
Defrost Control	Automatic
Defrost Thermostat	46.4 °F
Electrical Rating : 115VAC, 60Hz.....	1-5 A
Maximum Current Leakage	0.5mA
Maximum Ground Path Resistance	0.14 Ohms
Energy Consumption.....	.466kWh/yr (Energy Star)

1-4. NO LOAD PERFORMANCE

Control Position: MID/MID

And Ambient of:	70°F	90°F	
Fresh Food, °F.....	33°F to 41°F	Fresh Food, °F.....33°F to 41°F	
Frozen Food, °F.....	-4°F to +4°F	Frozen Food, °F.....-4°F to +4°F	
Percent Running Time	25% - 35%	Percent Running Time	45% - 60%

1-5. REFRIGERATION SYSTEM

Minimum Compressor Capacity Vacuum.....	21 in
Minimum Equalized Pressure	
@70°F.....	49 PSIG
@90°F.....	56 PSIG
Refrigerant R134a.....	4.2 oz
Compressor.....	.687 BTU/hr

1-6. INSTALLATION

Clearance must be provided at top, sides and rear of the refrigerator for air circulation.

At Top.....	2 in
At Sides.....	2 in
At Rear.....	2 in

1-7. REPLACEMENT PARTS

Relay.....	6748C-0004D
Overload.....	6750C-0005P
Defrost Thermostat.....	6930JK2001B
Defrost Heater.....	5300JB1100J
Evaporator Fan Motor.....	4681JB1027N
Capacitor.....	0CZZJB2012J
Compressor (Hi-Side).....	TCA33414101
Evaporator (Lo-Side).....	5421JJ1001B
Condenser.....	5403JJ1007A
Dryer.....	5851JA2007E
Condenser Fan Motor.....	4681JB1027P
Temperature Control.....	6500JB1001M
Main Control.....	EBR64110503

PERFORMANCE DATA (NORMAL OPERATING CONDITIONS)			
AMB	WATTS	SYSTEM PRESSURE (PSIG)	
		HIGH SIDE	LOW SIDE
70°F	98 (+10 / -10)	98 (+5 / -3)	(-5) to (-2)
90°F	98 (+10 / -10)	132 (+3 / -3)	(-4) to 1
110°F	103 (+5 / -5)	180 (+5 / -5)	(-2) to 3

1-8. AIR FLOW

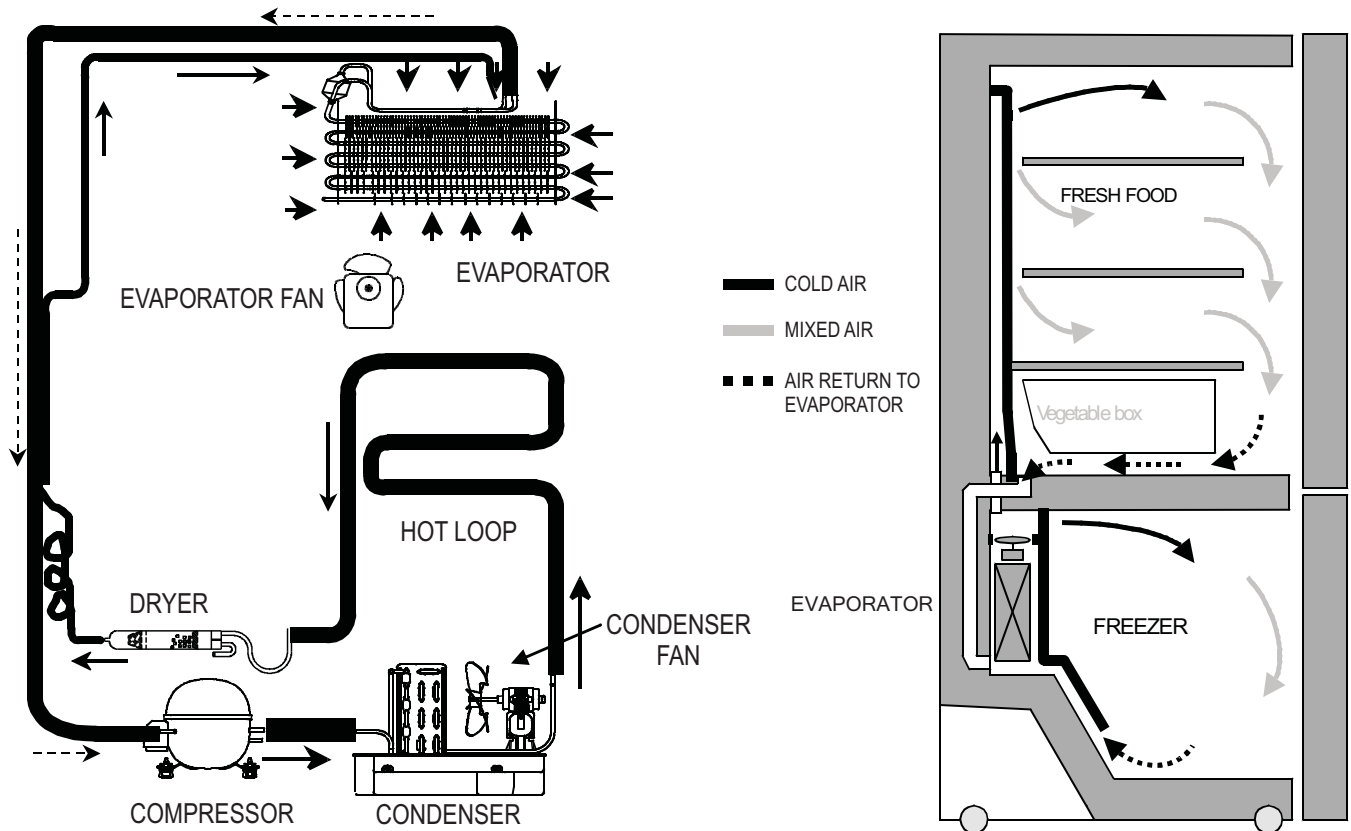

2. PARTS IDENTIFICATION

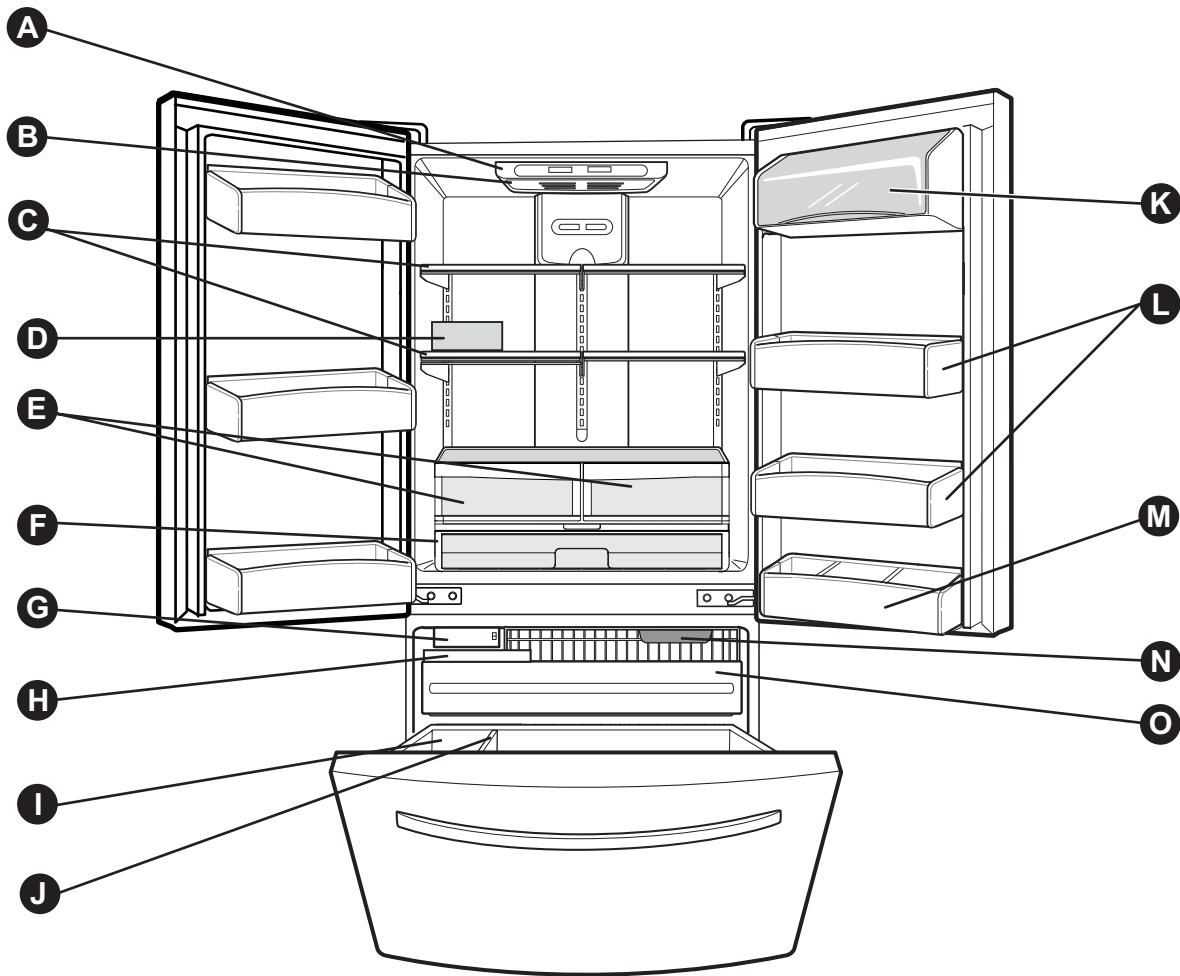

Use this section to become more familiar with the parts and features.

NOTE: This guide covers several different models. The refrigerator you have purchased may have some or all of the items listed below. The locations of the features shown below may not match your model.

- | | |
|---|----------------------------------|
| A Digital Sensor Control | K Dairy Corner |
| B Refrigerator Light | L Modular Door Bins |
| C Shelves | M Bottle Guide* |
| D Egg Box* | N Freezer Light |
| E Optibin Crispers
Keeps fruits and vegetable fresh and crisp | O Glide-Out Drawer Basket |
| F Pantry | |
| G Icemaker | |
| H Ice Bin | |
| I Durabase | |
| J Divider | |

*On some models

3. DISASSEMBLY

3-1 FAN AND FAN MOTOR

1. Remove the freezer shelf. (If your refrigerator has an icemaker, remove the icemaker first).
2. Remove the plastic guide for slides on left side by unscrewing phillips head screws.
3. Remove the grille by removing one screw and pulling the grille forward.
4. Remove the Fan Motor assembly by loosening 2 screw and disassemble the shroud.
5. Pull out the fan and separate the Fan Motor and Bracket.

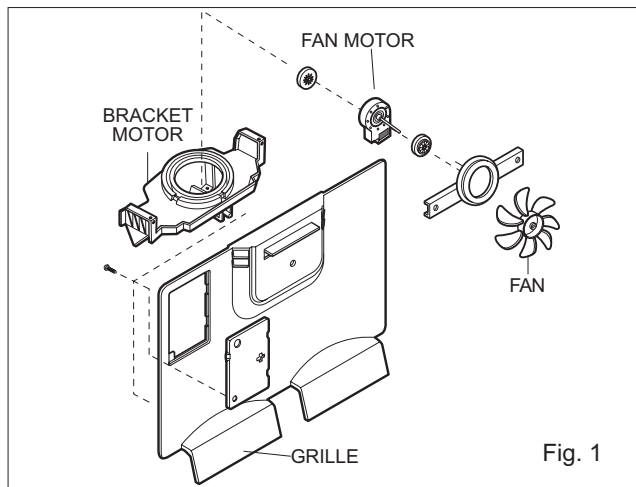

3-2 DEFROST CONTROL ASSEMBLY

Defrost Control assembly consist of Drefrost Sensor and FUSE-M.

The Defrost Sensor works to defrost automatically. It is attached to the metal side of the Evaporator and senses its temperature.

Fuse-M is safety device for preventing over-heating of the Heater when defrosting.

At 72°C, it turns the Defrost Heater off.

1. Pull out the grille assembly. (Figure 2)
2. Separate the connector with the Defrost Control assembly and replace the Defrost Control assembly after cutting the Tie Wrap. (Figure 3)

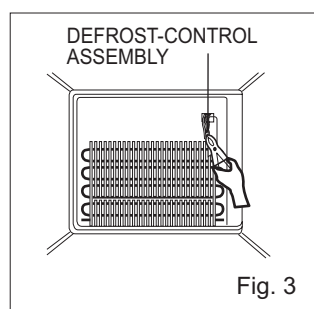
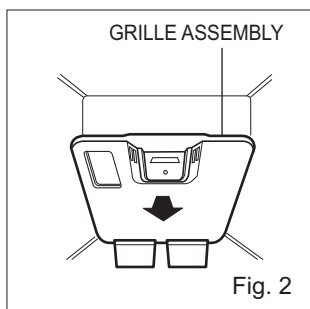

3-3 LAMP

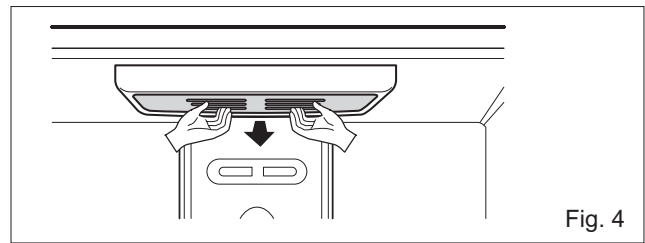

3-3-1 REFRIGERATOR COMPARTMENT LAMP

1. Unplug the power cord from the outlet.
2. Remove Refrigerator shelves.
3. Release the hooks on both ends of the lamp shield and pull the shield downward to remove it.
4. Turn the lamp counterclockwise.
5. Assemble in reverse order of disassembly.
6. Replacement bulb must be the same specification as the original (Max. 60 W-2EA).

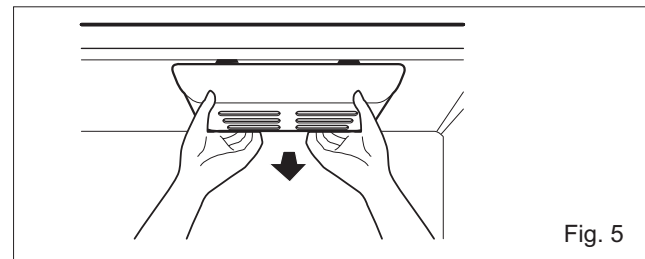

3-3-2 FREEZER COMPARTMENT LAMP

1. Unplug refrigerator or disconnect power.
2. Reach behind light to remove bulb.
3. Replace bulb with a 60W appliance bulb.
4. Plug in refrigerator or reconnect power.

3-4 CONTROL BOX-REFRIGERATOR

1. First, remove all shelves in the refrigerator, than remove the Refrigerator control Box by loosening 2 screws.

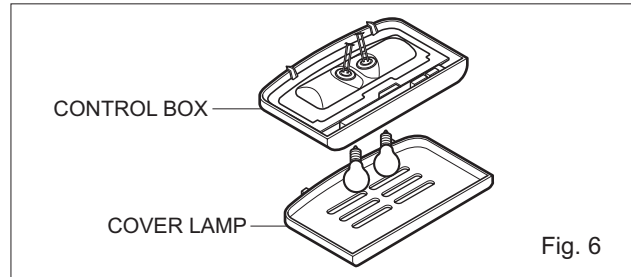

2. Remove the Refrigerator Control Box by pulling it downward.
3. Disconnect the lead wire on the right position and separate the lamp sockets.

3-5 MULTI DUCT

1. Remove an upper and lower Cap by using a flat screwdriver, and loosen 2 screws. (Figure 7)
2. Disconnect the lead wire on the botton position.

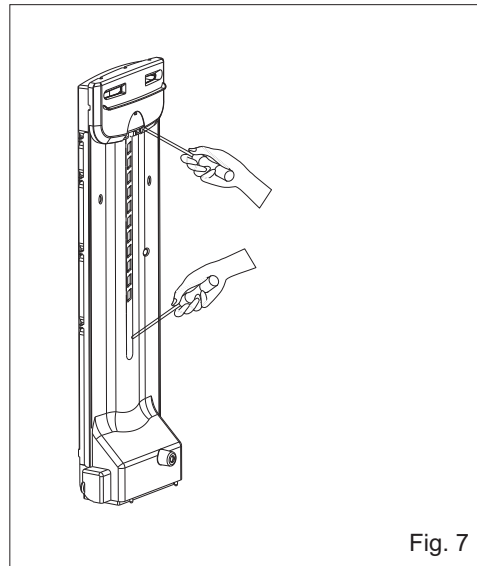

3-6 DOOR DISASSEMBLY

3-6-1 REMOVE REFRIGERATOR DOOR

IMPORTANT: Before you begin, turn the refrigerator OFF and Unplug it. Remove food and any bins from doors.

► Left Door

- Loosen the cover screws (1).
- Disconnect door switch wire (2).
- Loosen hinge bolts (3).
- Lift off the top hinge (4).
- Place the door on a non-scratching surface with the inside up.

► Right Door

- Loosen the cover screws (1).
- Disconnect door switch wire (2).
- Disconnect wire harness (5).
- Loosen hinge bolts (3).
- Loosen ground screw (6).
- Lift off the top hinge (4).
- Place the door on a non-scratching surface with the inside up.

CAUTION: When removing top hinge, be careful that the door does not fall forward.

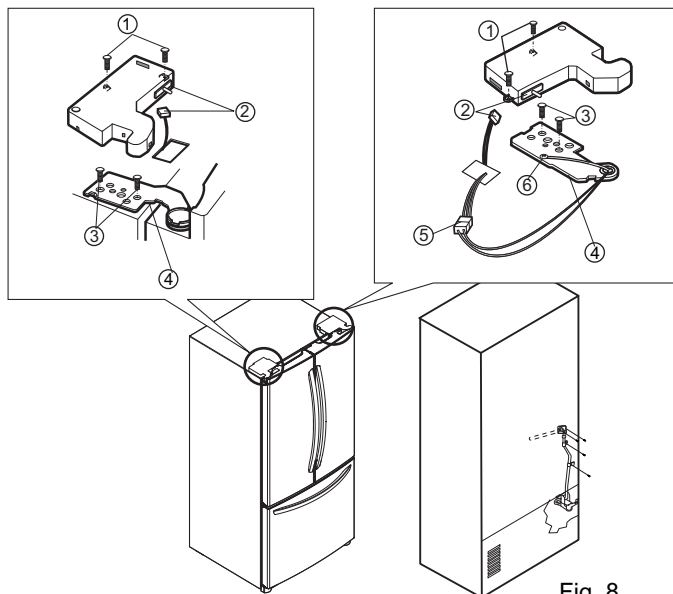

Fig. 8

3-6-2 REPLACE REFRIGERATOR DOOR

► Right Door

- Lower the door onto the middle hinge pin (7).
- Make sure the door is aligned with the cabinet.
- Replace the top hinge (4) installing hinge screws (3) to secure it.
- Make sure the gasket on the door is flush against the cabinet and is not folded.
- Support the door on the handle side while securing. And make sure the door is straight and the gap between the doors is even across the front.
- Install the ground screw (6).
- Connect the door switch wire (2).
- Tighten the cover screw (1).

► Left Door

- Lower the door onto the middle hinge pin (5).
- Make sure the door is aligned with the cabinet.
- Replace the top hinge (4) installing hinge screws (3) to secure it.
- Make sure the gasket on the door is flush against the cabinet and is not folded.
- Support the door on the handle side while securing. And make sure the door is straight and the gap between the doors is even across the front.
- Connect the door switch wire (2).
- Tighten the cover screw (1).

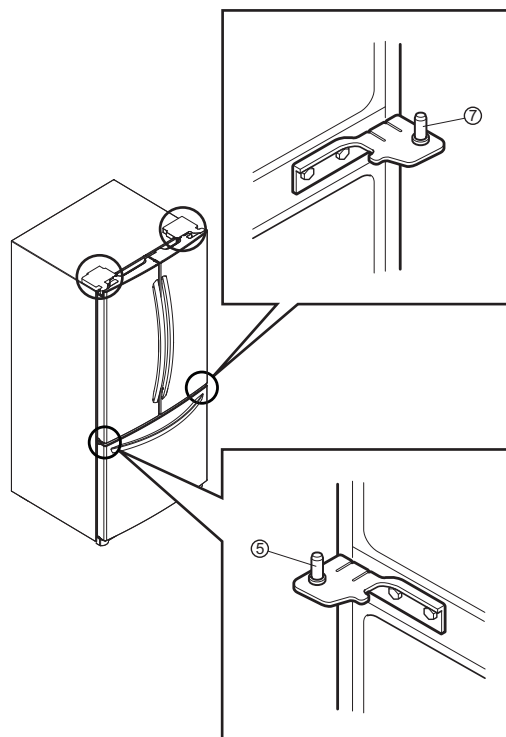

Fig. 9

3-6-3 PULL OUT DRAWER

(a) HOW TO REMOVE PULL OUT DRAWER

IMPORTANT: To avoid possible injury, product or property damage, you will need two people to perform the following instructions.

- Pull the drawer open to full lower extension. Remove durabase by lifting it from rail system.

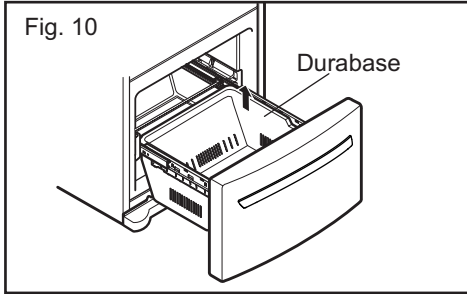

- Press both hangers with your thumbs to lift it up.

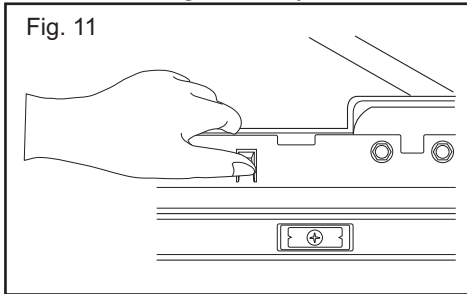

- Separate the left and right rail cover

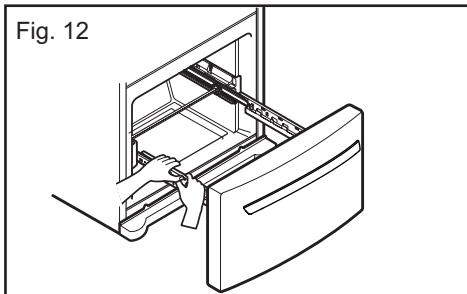

- Remove the screws of the rail on both sides.

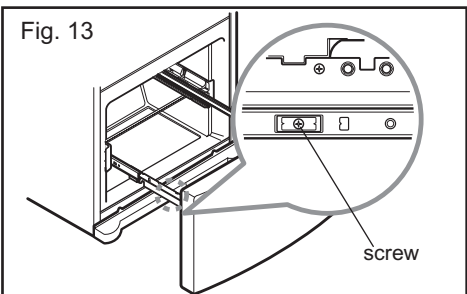

CAUTION: When removing drawer door, do not hold it by the handle. Door could fall down and you may be injured grasp door with both hands as pictured below When removing.

CAUTION: When laying down the drawer, be careful not to damage the floor or hurt your feet with the sharp edges on hinge side.

- With both hands, hold both sides of the door and pull it up to separate it from the rails.

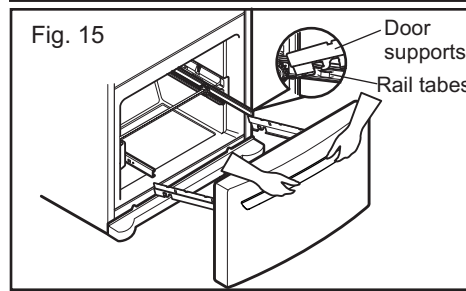
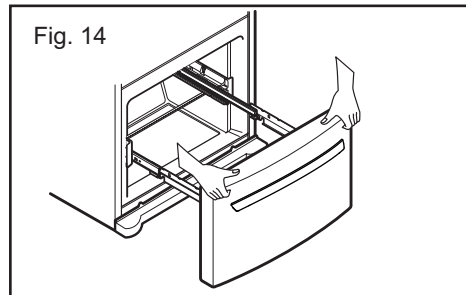

- Push rails back into drawer cavity. With both hands, hold the center of the bar and push it in so that both rails go back simultaneously.

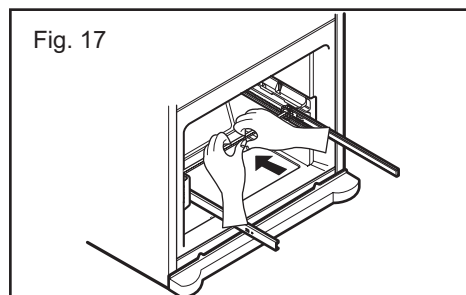
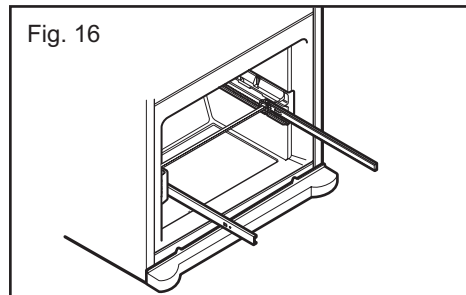

(b) HOW TO INSTALL PULL OUT DRAWER

IMPORTANT: To avoid possible injury, product or property damage, you will need two people to perform the following instructions.

- With both hands, hold the center of the bar and pull it out to let both rails out to full extension simultaneously.

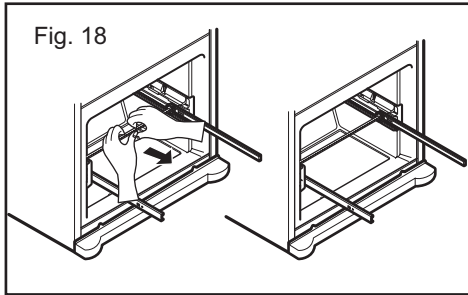

- Hook door supports into rail tabs.

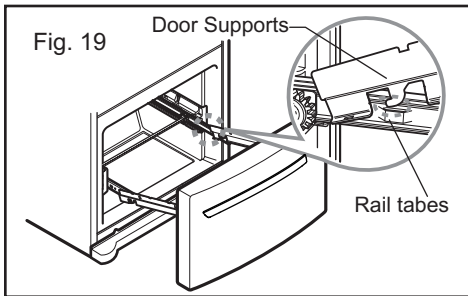

- Lower door into final position and tighten the screws.

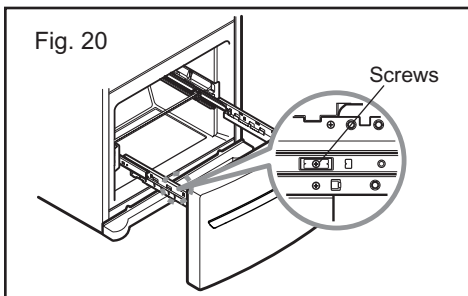

- Make sure you have a right rail cover for each side.

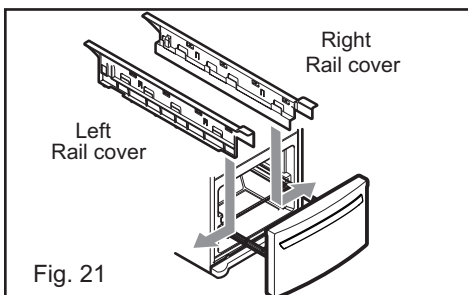

- Align the top holes of the rail cover with the top holes of the door supports to assemble the rail cover.

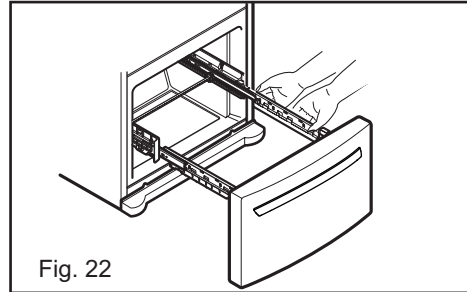

- Verify the hole's assembly

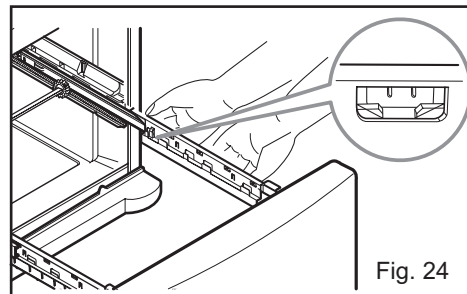
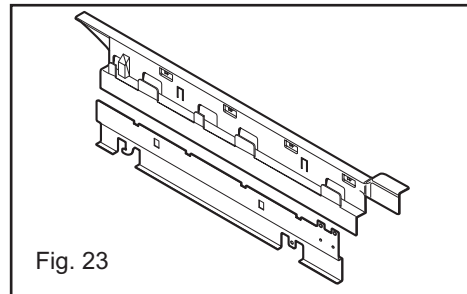

- With the rails pulled out to full extension, insert the durabase in the rail assembly.

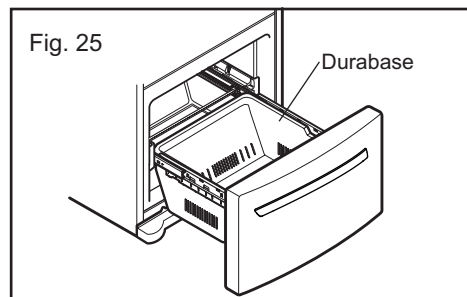

▲ WARNING: To prevent accidental child and pet entrapment or suffocation risk. DO NOT allow them to play inside of drawer.

▲ WARNING: DO NOT step or sit down on Freezer Door.

3-6-4 HOW TO REMOVE DOOR HANDLES

NOTE: Handle appearance may vary from illustrations on this page.

1. Removing Refrigerator Handle

- Loosen the set screws with the 3/32" Allen wrench and remove the handle.

NOTE: If the handle mounting fasteners need to be tightened or removed, use a 1/4" Allen wrench.

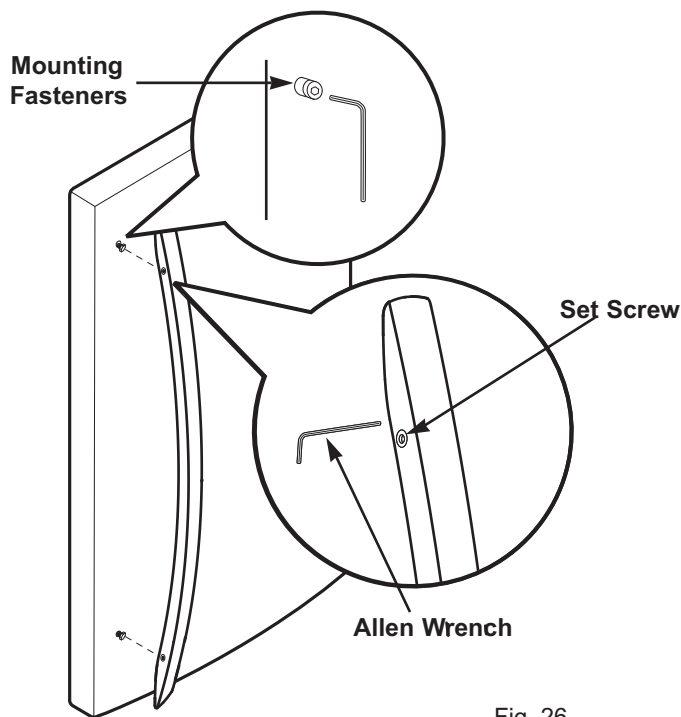

Fig. 26

2. Removing Freezer Drawer Handle

- Loosen the set screws located on the lower side of the handle with the 3/32" Allen wrench and remove the handle.

NOTE: If the handle mounting fasteners need to be tightened or removed, use a 1/4" Allen wrench.

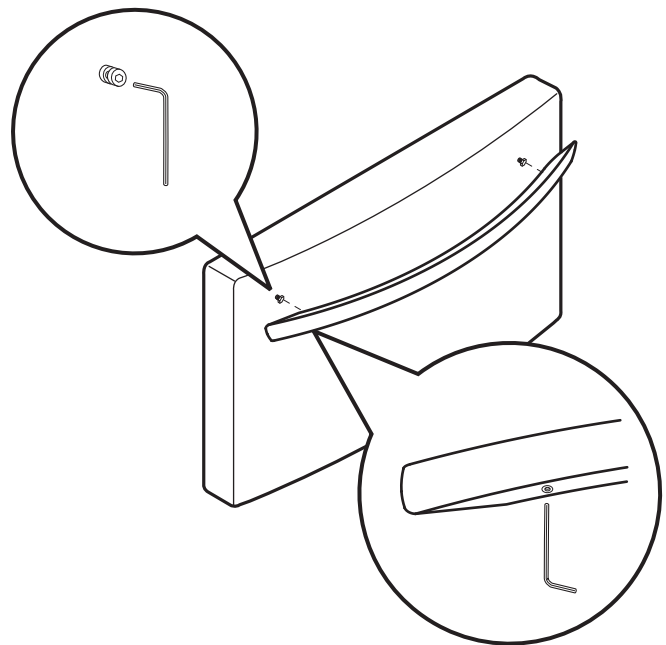

Fig. 27

3-7 LEVELING AND DOOR ALIGNMENT

(a) LEVELING

Your refrigerator has two front leveling screws one on the right and one on the left. If your refrigerator seems unsteady or you want the doors to close easier, adjust the Refrigerator's tilt using the instructions below:

1. Plug the refrigerator's power cord into a 3-prong grounded outlet. Move the refrigerator into its final position.
2. Turn the leveling screw clockwise to raise that side of the refrigerator or counterclockwise to lower it. It may take several turns of the leveling screw to adjust the tilt of the refrigerator.

NOTE: Having someone push against the top of the refrigerator takes some weight off the leveling screws. This makes it easier to adjust the screws.

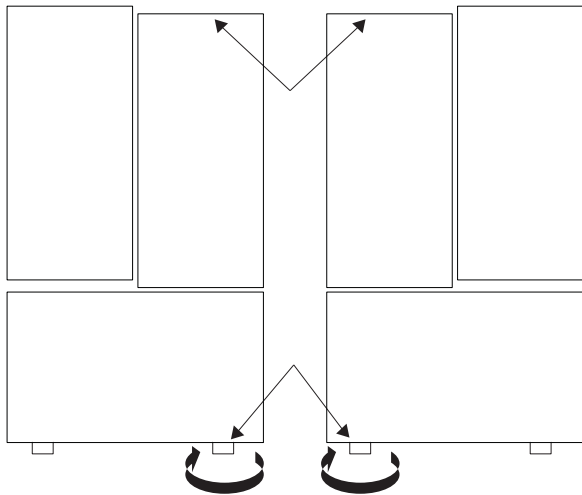

Fig. 28

3. Open both doors again and check to make sure that they close easily. If not, tilt the refrigerator slightly more to the rear by turning both leveling screws clockwise. It may take several more turns, and you should turn both leveling screws the same amount.
4. Re-adjust if necessary.
5. Replace the base cover.

NOTE: Your new refrigerator is uniquely designed with two fresh food doors. Either door can be opened or closed independently of one another. You may have to exert slight pressure on doors to get them to close completely.

(b) DOOR ALIGNMENT

If the space between your doors is uneven, follow the instructions below to align the doors:

1. With one hand, lift up the door you want to raise at middle hinge.
2. With other hand, use pliers to insert snap ring as shown.
3. Insert additional snap rings until the doors are aligned. (Three snap rings are provided with unit.)

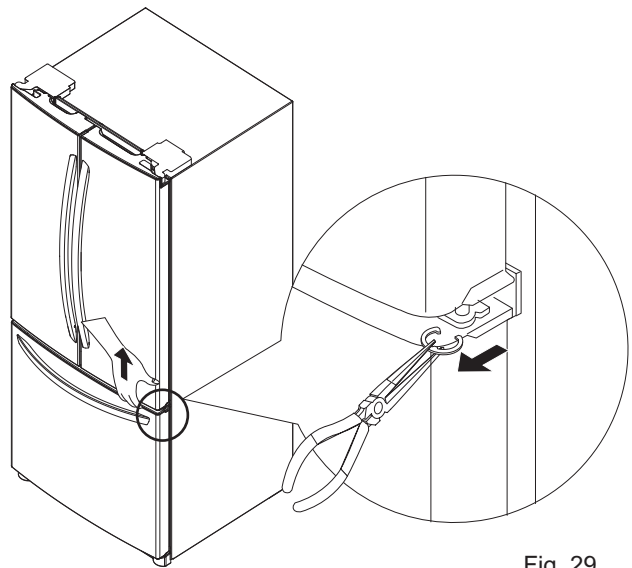

Fig. 29

4. ADJUSTMENT

4-1 COMPRESSOR

4-1-1 Role

The compressor intakes low temperature and low pressure gas from the evaporator of the refrigerator and compresses this gas to high-temperature and high-pressure gas. It then delivers the gas to the condenser.

4-1-2 Composition

The compressor includes overload protection. The PTC starter and OLP (overload protector) are attached to the outside of the compressor. Since the compressor is manufactured to tolerances of 1 micron and is hermetically sealed in a dust and moisture-free environment, use extreme caution when repairing it.

4-1-3 Note for Usage

- (1) Be careful not to allow over-voltage and over-current.
- (2) If compressor is dropped or handled carelessly, poor operation and noise may result.
- (3) Use proper electric components appropriate to the Particular Compressor in your product.
- (4) Keep Compressor dry.
If the Compressor gets wet (in the rain or a damp environment) and rust forms in the pin of the Hermetic Terminal, poor operation and contact may result.
- (5) When replacing the Compressor, be careful that dust, humidity, and soldering flux don't contaminate the inside of the compressor. Dust, humidity, and solder flux contaminate the cylinder and may cause noise, improper operation or even cause it to lock up.

4-2 PTC-STARTER

4-2-1 Composition of PTC-Starter

- (1) PTC (Positive Temperature Coefficient) is a no-contact semiconductor starting device which uses ceramic material consisting of BaTiO₃.
- (2) The higher the temperature is, the higher the resistance value. These features are used as a starting device for the Motor.

4-2-2 Role of PTC-Starter

- (1) The PTC is attached to the Sealed Compressor and is used for starting the Motor.
- (2) The compressor is a single-phase induction motor. During the starting operation, the PTC allows current flow to both the start winding and main winding.

4-2-3 PTC-Applied Circuit Diagram Starting Method for the Motor

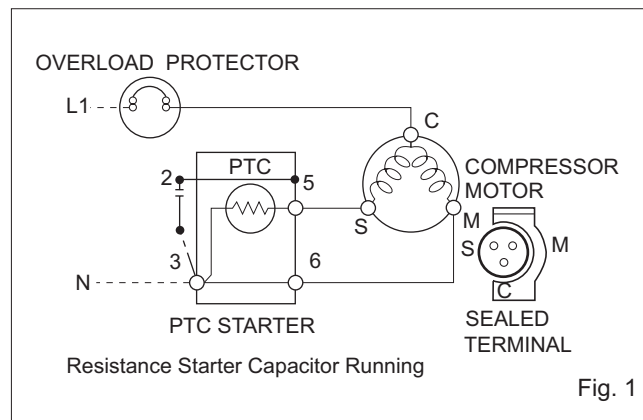

4-2-4 Motor Restarting and PTC Cooling

- (1) It requires approximately 5 minutes for the pressure to equalize before the compressor can restart.
- (2) The PTC device generates heat during operation. Therefore, it must be allowed to cool before the compressor can restart.

4-2-5 Relation of PTC-Starter and OLP

- (1) If the compressor attempts to restart before the PTC device is cooled, the PTC device will allow current to flow only to the main winding.
- (2) The OLP will open because of the over current condition. This same process will continue (3 to 5 times) when the compressor attempts to restart until the PTC device has cooled. The correct OLP must be properly attached to prevent damage to the compressor.

Parts may appear physically identical but could have different electrical ratings. Replace parts by part number and model number. Using an incorrect part could result in damage to the product, fire, injury, or possibly death.

4-2-6 Note for Using the PTC-Starter

- (1) Be careful not to allow over-voltage and over-current.
- (2) Do not drop or handle carelessly.
- (3) Keep away from any liquid.
If liquid such as oil or water enters the PTC, PTC materials may fail due to breakdown of their insulating capabilities.
- (4) If the exterior of the PTC is damaged, the resistance value may be altered. This can cause damage to the compressor and result in a no-start or hard-to-start condition.
- (5) Always use the PTC designed for the compressor and make sure it is properly attached to the compressor. Parts may appear physically identical but could have different electrical ratings. Replace parts by part number and model number. Using an incorrect part could result in damage to the product, fire, injury, or possibly death.

4-3 OLP (OVERLOAD PROTECTOR)

4-3-1 Definition of OLP

- (1) OLP (OVERLOAD PROTECTOR) is attached to the Compressor and protects the Motor by opening the circuit to the Motor if the temperature rises and activating the bimetal spring in the OLP.
- (2) When high current flows to the Compressor motor, the Bimetal works by heating the heater inside the OLP, and the OLP protects the Motor by cutting off the current flowing to the Compressor Motor.

4-3-2 Role of the OLP

- (1) The OLP is attached to the Sealed Compressor used for the Refrigerator. It prevents the Motor Coil from being started in the Compressor.
- (2) For normal operation of the OLP, do not turn the Adjust Screw of the OLP in any way.

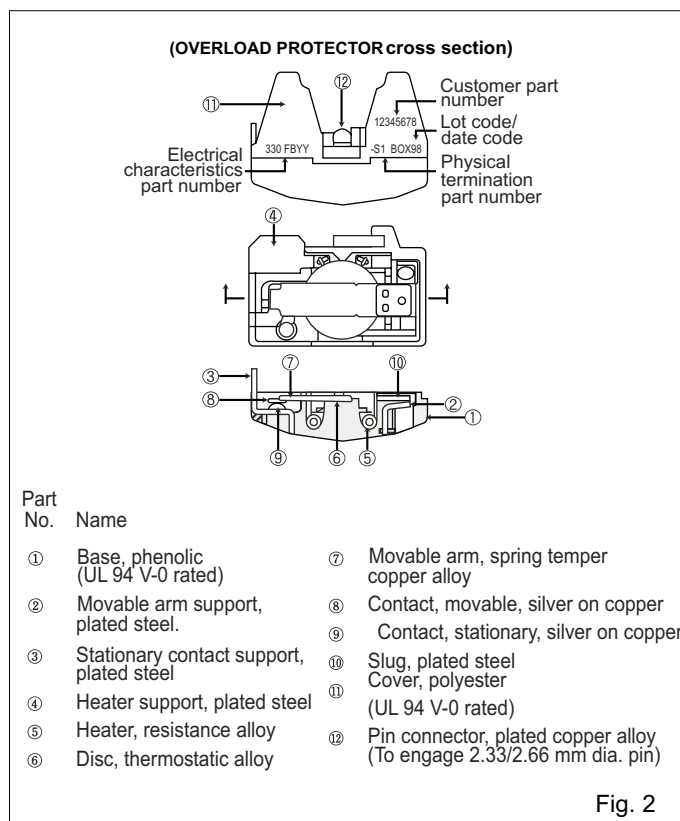

5. CIRCUIT DIAGRAM

CIRCUIT DIAGRAM

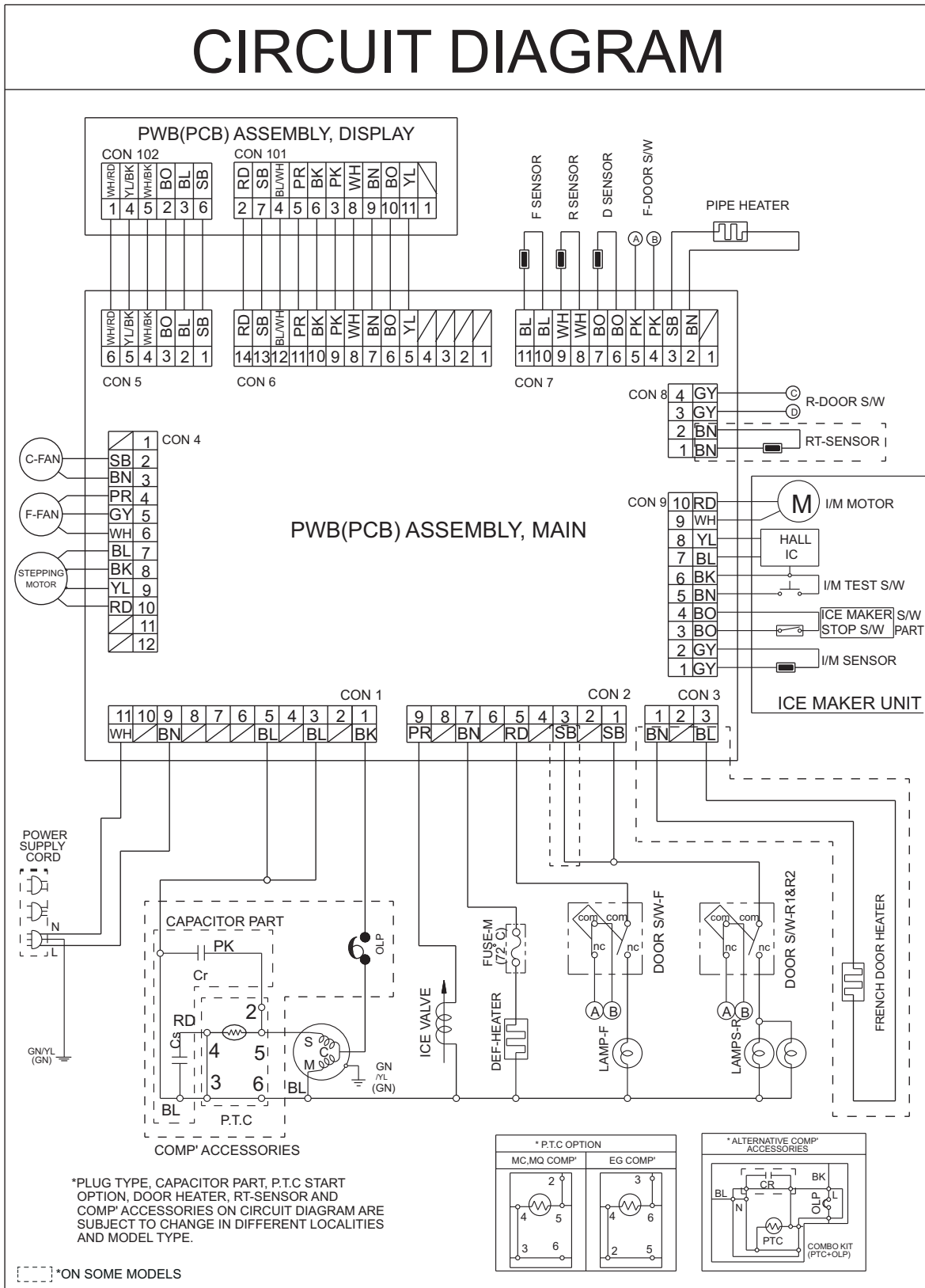

BK: BLACK	GN: GREEN	GY: GRAY	GN/YL: GREEN/YELLOW
YL: YELLOW	PK: PINK	WH: WHITE	BL/WH: BLUE/WHITE
SB: SKY BLUE	BO: BRIGHT ORANGE	BL: BLUE	BK/WH: BLACK/WHITE
BN: BROWN	PR: PURPLE	RD: RED	RD/WH: RED/WHITE

6. TROUBLESHOOTING

6-1. COMPRESSOR AND ELECTRIC COMPONENTS

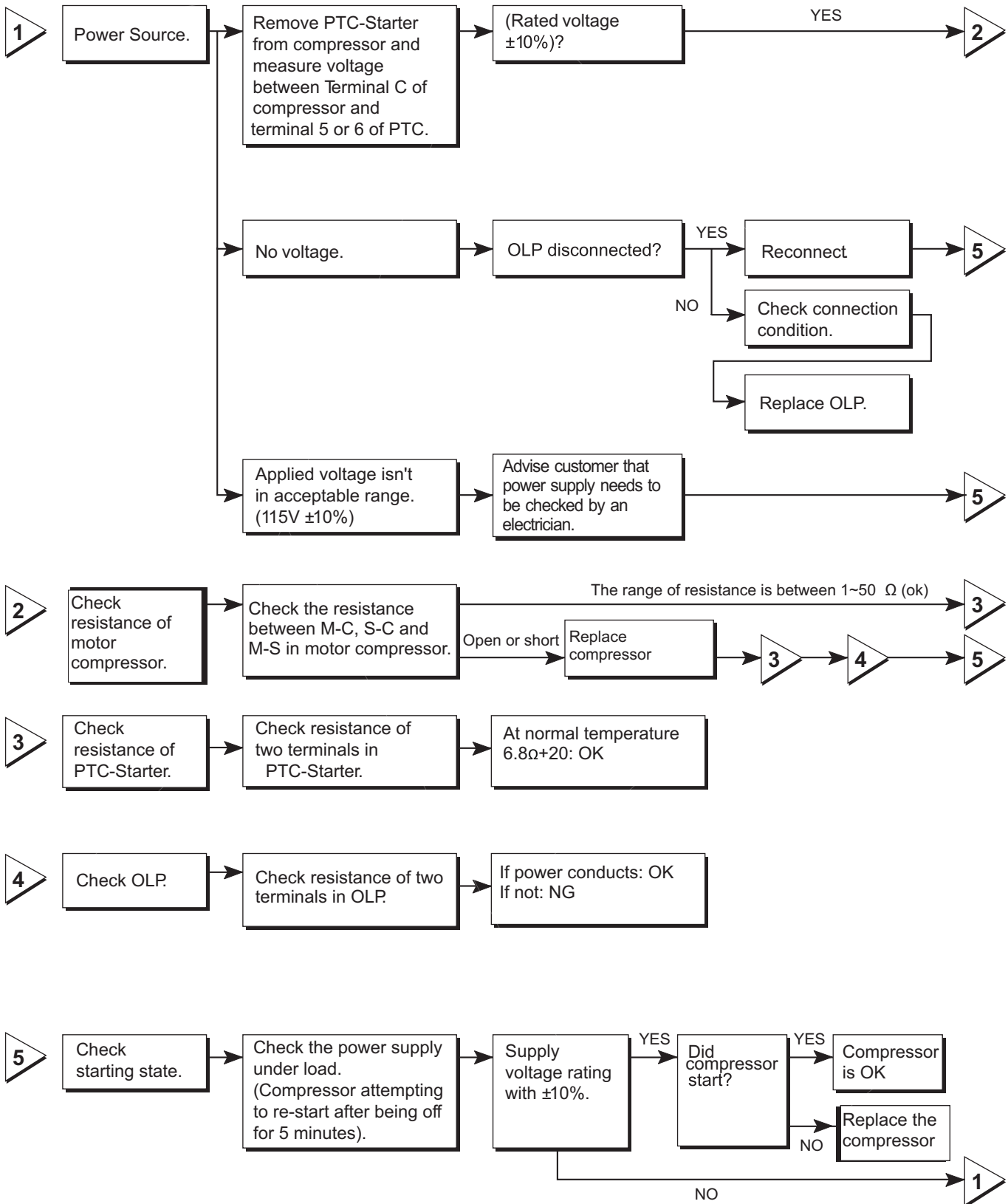

6-2. PTC AND OLP

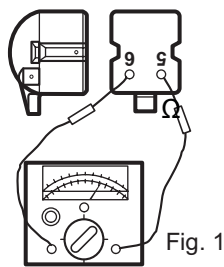
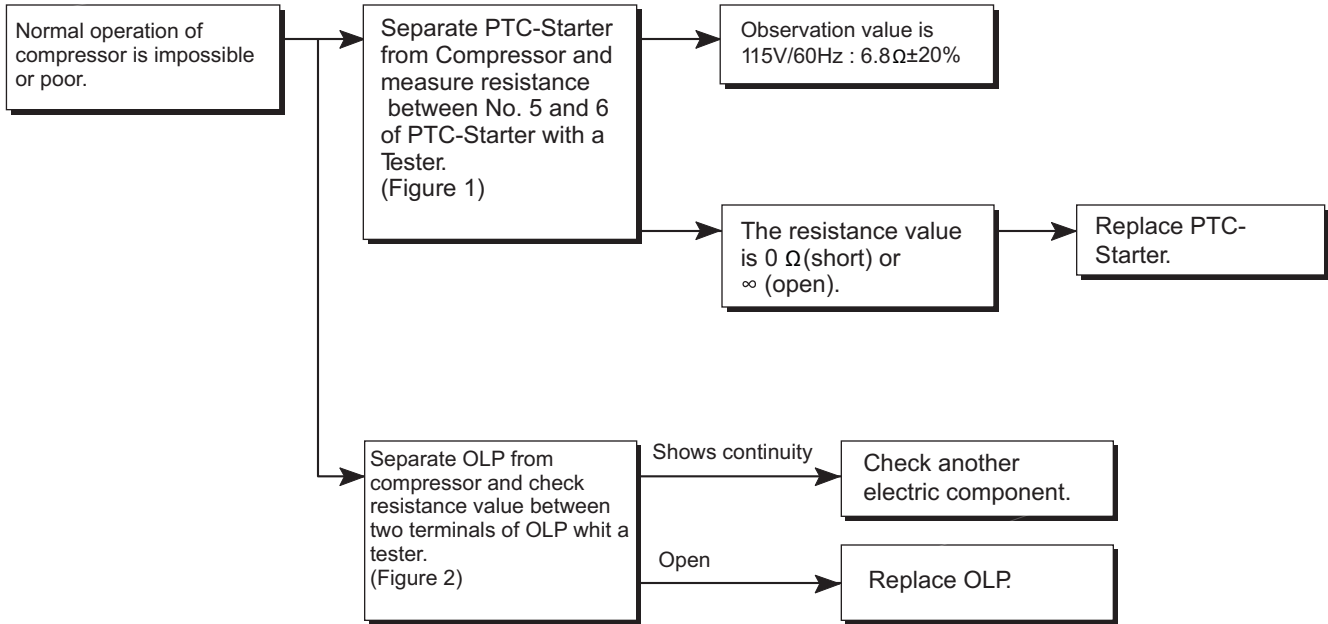

Fig. 1

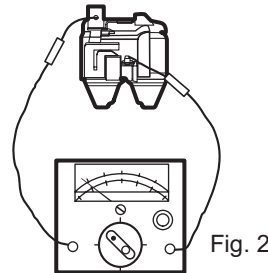
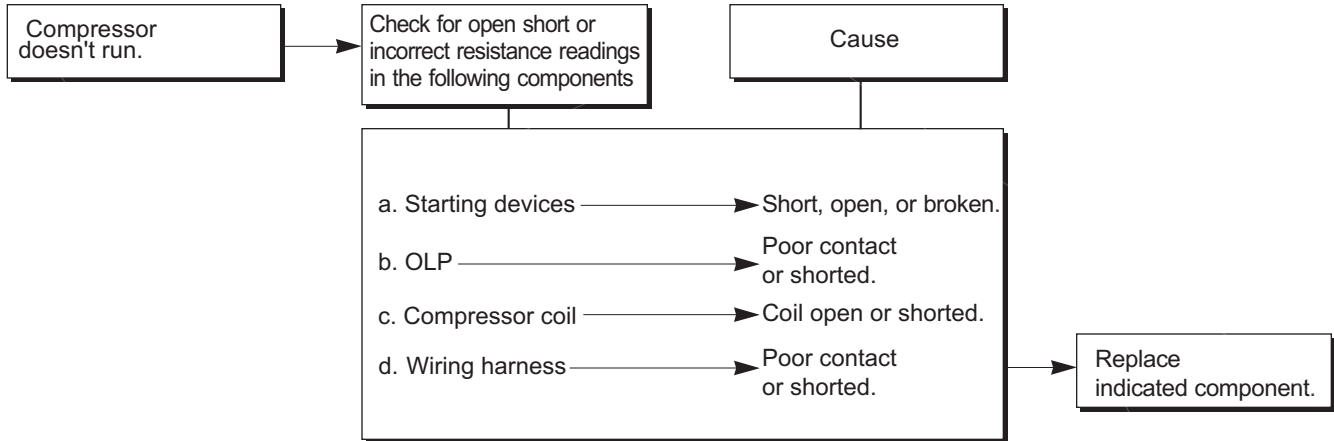

Fig. 2

6-3 OTHER ELECTRICAL COMPONENTS

• Not cooling at all



• Poor cooling performance

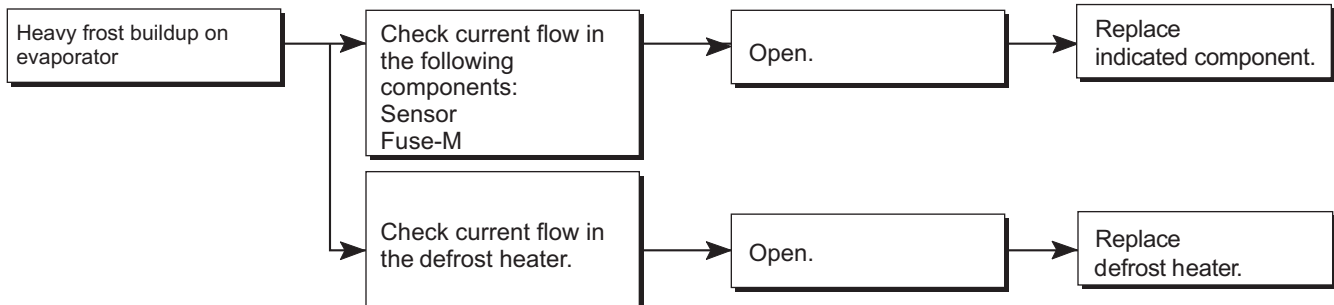
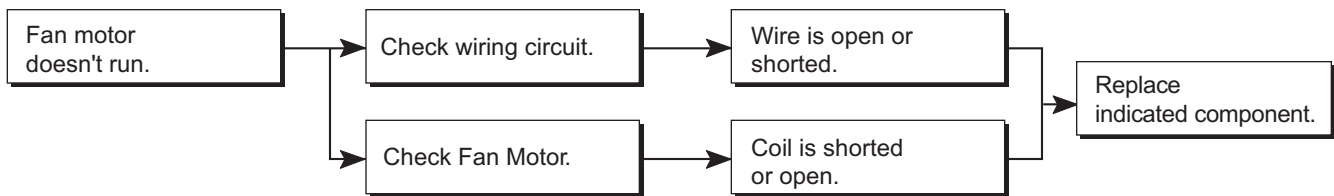
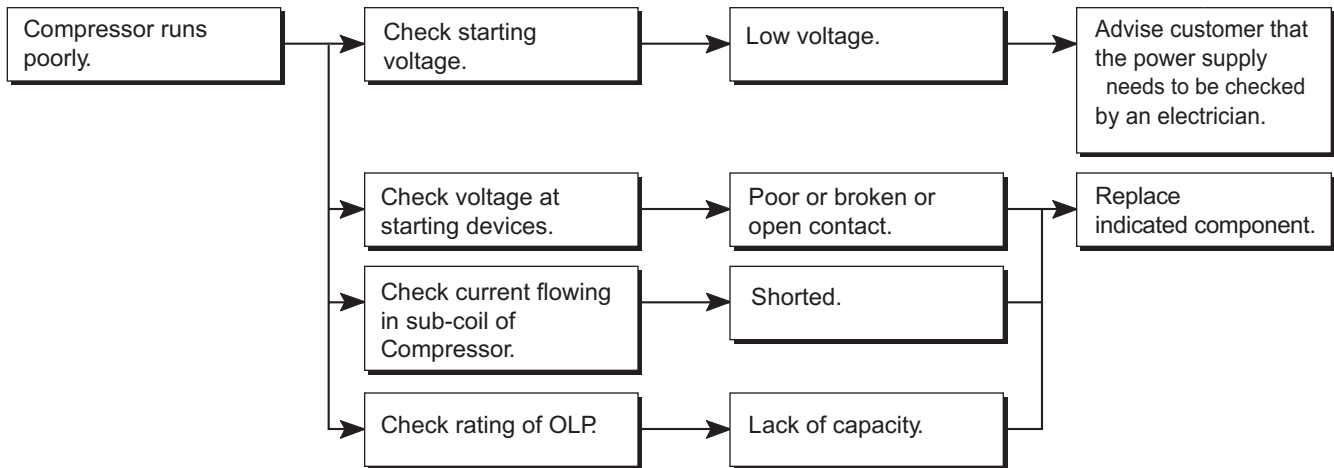

6-4 SERVICE DIAGNOSIS CHART

COMPLAINT	POINTS TO BE CHECKED	REMEDY
No Cooling.	<ul style="list-style-type: none"> • Is the power cord unplugged from the outlet? • Check if the power switch is set to OFF. • Check if the fuse of the power switch is shorted. • Measure the voltage of the power outlet. 	<ul style="list-style-type: none"> • Plug into the outlet. • Set the switch to ON. • Replace the fuse. • If the voltage is low, correct the wiring.
Cools poorly.	<ul style="list-style-type: none"> • Check if the unit is placed too close to the wall. • Check if the unit is placed too close to the stove, gas cooker, or in direct sunlight. • Is the ambient temperature too high or the room door closed? • Check if food put in the refrigerator is hot. • Did you open the door of the unit too often or check if the door is sealed properly? • Check if the Control is set to Warm position. 	<ul style="list-style-type: none"> • Place the unit about 4 inches (10 cm) from the wall. • Place the unit away from these heat sources. • Lower the ambient temperature. • Put in foods after they have cooled down. • Don't open the door too often and close it firmly. • Set the control to Recommended position.
Foods in the Refrigerator are frozen.	<ul style="list-style-type: none"> • Is food placed in the cooling air outlet? • Check if the control is set to colder position. • Is the ambient temperature below 41°F(5°C)? 	<ul style="list-style-type: none"> • Place foods in the high-temperature section. (front part) • Set the control to Recommended position. • Set the control to Warm position.
Condensation or ice forms inside the unit.	<ul style="list-style-type: none"> • Is liquid food sealed? • Check if food put in the refrigerator is hot. • Did you open the door of the unit too often or check if the door is sealed properly? 	<ul style="list-style-type: none"> • Seal liquid foods with wrap. • Put in foods after they have cooled down. • Don't open the door too often and close it firmly.
Condensation forms in the Exterior Case.	<ul style="list-style-type: none"> • Check if the ambient temperature and humidity of the surrounding air are high. • Is there a gap in the door gasket? 	<ul style="list-style-type: none"> • Wipe moisture with a dry cloth. It will disappear in low temperature and humidity. • Fill up the gap.
There is abnormal noise.	<ul style="list-style-type: none"> • Is the unit positioned in a firm and even place? • Are any unnecessary objects placed in the back side of the unit? • Check if the Tray Drip is not firmly fixed. • Check if the cover of the compressor enclosure in the front lower side is taken out. 	<ul style="list-style-type: none"> • Adjust the Leveling Screw, and position the refrigerator in a firm place. • Remove the objects. • Fix the Tray Drip firmly in the original position. • Place the cover in its original position.
Door does not close well.	<ul style="list-style-type: none"> • Check if the door gasket is dirty with an item like juice. • Is the refrigerator level? • Is there too much food in the refrigerator? 	<ul style="list-style-type: none"> • Clean the door gasket. • Position in the firm place and level the Leveling Screw. • Make sure food stored in shelves does not prevent the door from closing.
Ice and foods smell unpleasant.	<ul style="list-style-type: none"> • Check if the inside of the unit is dirty. • Are foods with a strong odor unwrapped? • The unit smells of plastic. 	<ul style="list-style-type: none"> • Clean the inside of the unit. • Wrap foods that have a strong odor. • New products smell of plastic, but this will go away after 1-2 weeks.

• Other possible problems:

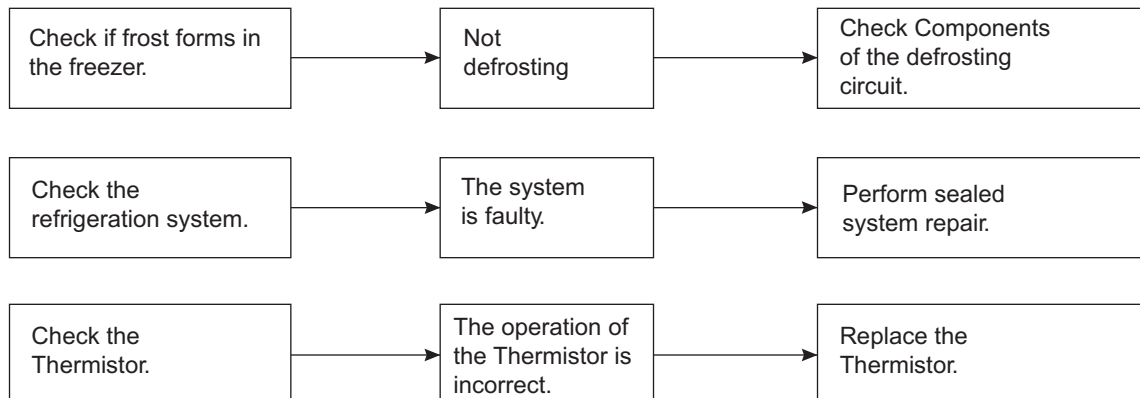

6-5 REFRIGERATION CYCLE

• Troubleshooting Chart

CAUSE		STATE OF THE UNIT	STATE OF THE EVAPORATOR	TEMPERATURE OF THE COMPRESSOR	REMARKS
LEAKAGE	PARTIAL LEAKAGE	Freezer compartment and refrigerator don't cool normally	Low flowing sound of refrigerant is heard and frost forms in inlet only.	A little higher than ambient temperature.	Refrigerant level is low due to a leak. Normal cooling is possible by restoring the normal amount of refrigerant and repairing the leak.
	COMPLETE LEAKAGE	Freezer compartment and refrigerator don't cool normally	Flowing sound of refrigerant is not heard and frost isn't formed.	Equal to ambient temperature.	No discharging of refrigerant. Normal cooling is possible by restoring the normal amount of refrigerant and repairing the leak.
RESTRICTION	PARTIAL RESTRICTION	Freezer compartment and refrigerator don't cool normally	Flowing sound of refrigerant is heard and frost forms in inlet only.	A little higher than ambient temperature.	Normal discharging of the refrigerant. The capillary tube is faulty.
	COMPLETE RESTRICTION	Freezer compartment and refrigerator don't cool.	Flowing sound of refrigerant is not heard and frost isn't formed.	Equal to ambient temperature.	Normal discharging of the refrigerant.
MOISTURE RESTRICTION		Cooling operation stops periodically.	Flowing sound of refrigerant is not heard and frost melts.	Lower than ambient temperature.	Cooling operation restarts when heating the inlet of the capillary tube.
DEFECTIVE COMPRESSION	COMPRESSSION	Freezer and refrigerator don't cool.	Low flowing sound of refrigerant is heard and frost forms in inlet only.	A little higher than ambient temperature.	Low pressure at high side of compressor due to low refrigerant level.
	NO COMPRESSSION	No compressing operation.	Flowing sound of refrigerant is not heard and there is no frost.	Equal to ambient temperature	No pressure in the high pressure part of the compressor.

6-5-1 SEALED SYSTEM DIAGNOSIS

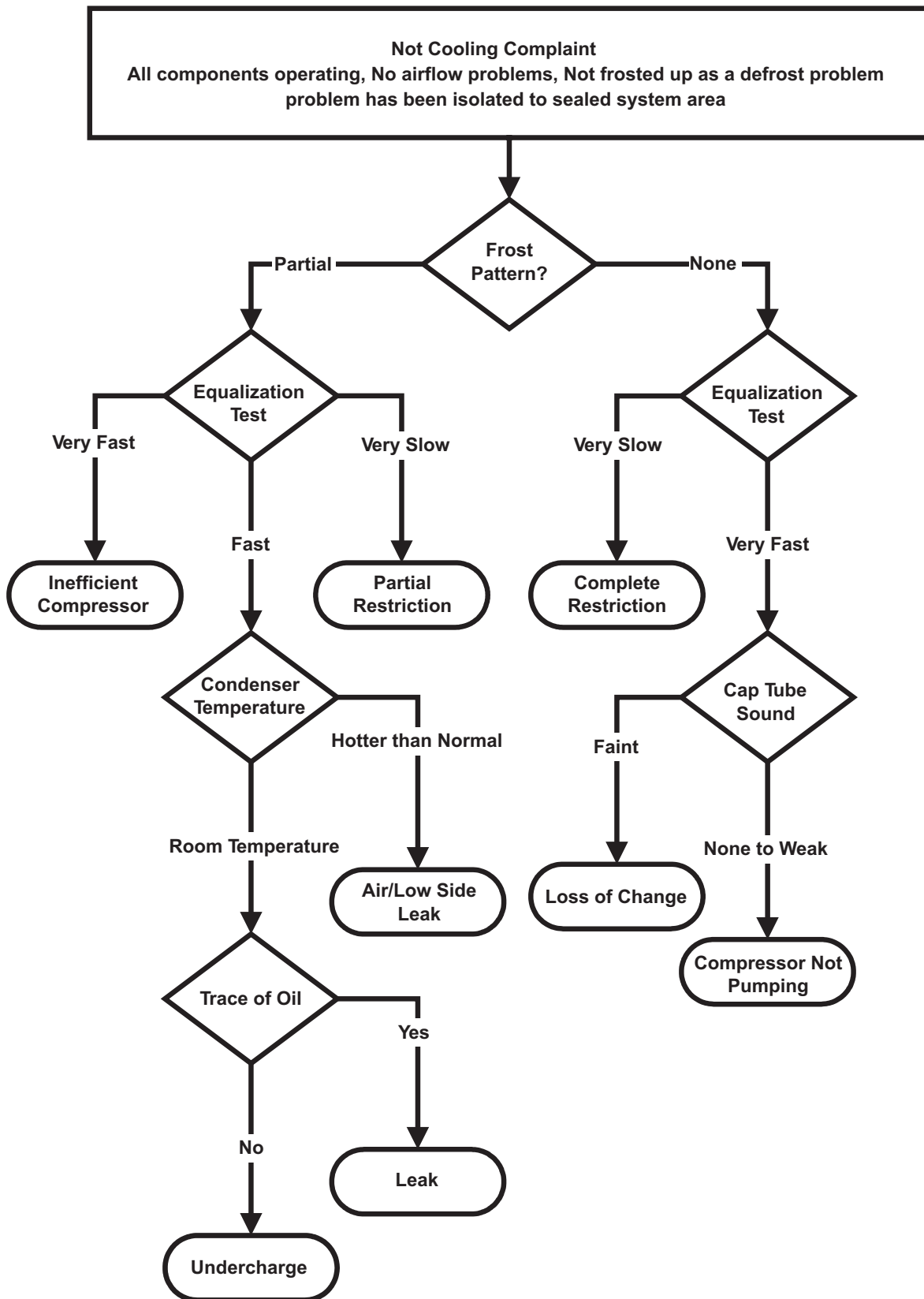

(The equalization test is trying to restart a compressor after it has been operating.)

7. OPERATION PRINCIPLE AND REPAIR METHOD OF ICEMAKER

7-1 OPERATION PRINCIPLE

7-1-1 Operation Principle of Icemaker

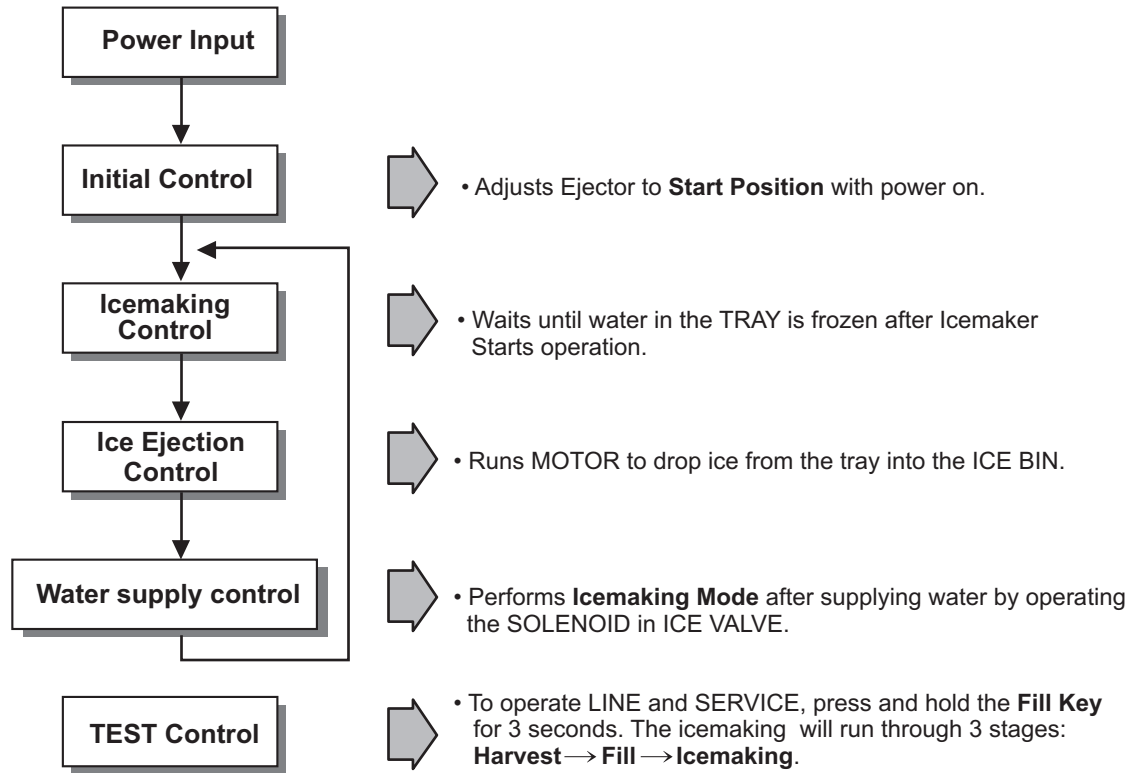

1. Turning the Icemaker stop switch off (O) stops the icemaking function.
2. Setting the Icemaker switch to OFF and then turning it back on will reset the icemaker control.

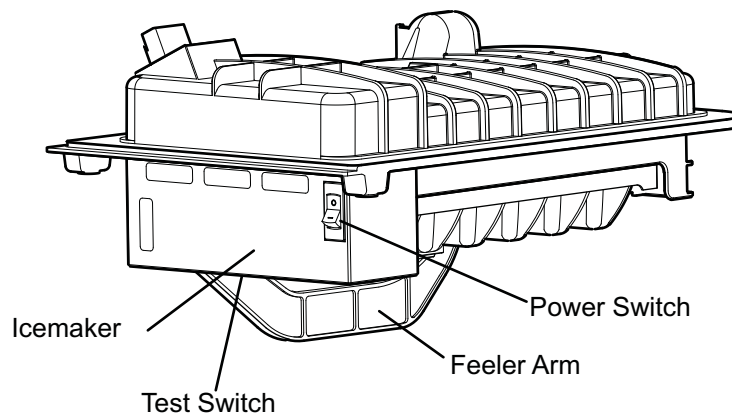

7-2 ICEMAKER FUNCTIONS

7-2-1 Start Position

- 1) When power is initially applied or reapplied after power is cut, it detects level of the TRAY after completion of MICOM initialization. The detecting lever moves up and down.
- 2) The level of icemaker tray is judged by output signal, high and low signal, of HALL SENSOR. Make the tray to horizontal by rotating ice ejection motor in normal or reverse direction so that High/Low signal can be applied to MICOM Pin (P22).
- 3) If there is no change in signals one minute after the geared motor starts to operate, it stops icemaker operation and check the signal every hour. It resets initialization of icemaker when it becomes normal. Ice ejection conducts for 1 cycle.

7-2-2 Icemaking Mode

- a) Ice making control is carried out from the completion of water supply to the completion of ice making in the TRAY. Ice making sensor detects the temperature of TRAY and completes ice making. (Ice making sensor is fixed below the TRAY.)
- b) Ice making control starts after completion of water supply control or initial control. Under the ice making control, the F room temperature should be operated with the NOTCH of "Normal/Strong".
- c) It is judged that ice making is completed when ice making sensor temperature reaches at -8 after 70 minutes + 10 minutes when water is supplied to the TRAY.

7-2-3 Ice Ejection Mode

- a) This is to eject ice from the TRAY after ice making is completed.
- b) If Hall IC signal is on within 3.6 seconds after ice ejection motor rotates in normal direction, it does not proceed ice ejection but waits. If the ice bank is full, ice ejection motor rotates in normal direction in every hour to check the condition of ice bank. If the ice bank is not full, the water supply control starts after completion of ice ejection control. If the ice bank is full, ice ejection motor rotates in reverse direction and stops under ice making or waiting conditions.
- c) If ice bank is not full, ice ejection starts. The TRAY tilts to the maximum and ice is separated from the TRAY and ice checking lever raises.
- d) Ice ejection motor stops for 1 second if Hall IC signal changes from OFF (low) to ON (high) after 3.6 seconds when ice ejection motor rotates in normal direction. If there is no change in Hall IC signals within 1 minute after ice ejection motor operates, ice ejection motor stops as ice ejection motor or hall IC is out of order.
- e) If ice ejection motor or Hall IC is abnormal, ice ejection motor rotates in normal direction to exercise initial operation in every hour. It resets the ice maker if ice ejection motor or Hall IC is normal.
- f) The TRAY stops for 1 second at maximum tilted conditions.
- g) The TRAY returns to horizontal conditions as ice ejection motor rotates in reverse direction.
- h) When the TRAY becomes horizontal, the cycle starts to repeat.
Water Supply – Ice making – Ice ejection – TRAY returns to Horizontal.

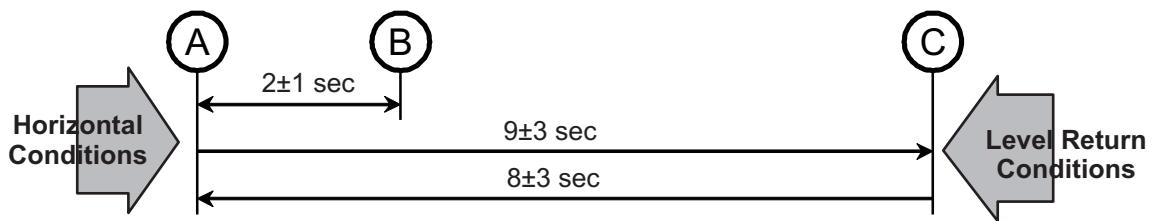
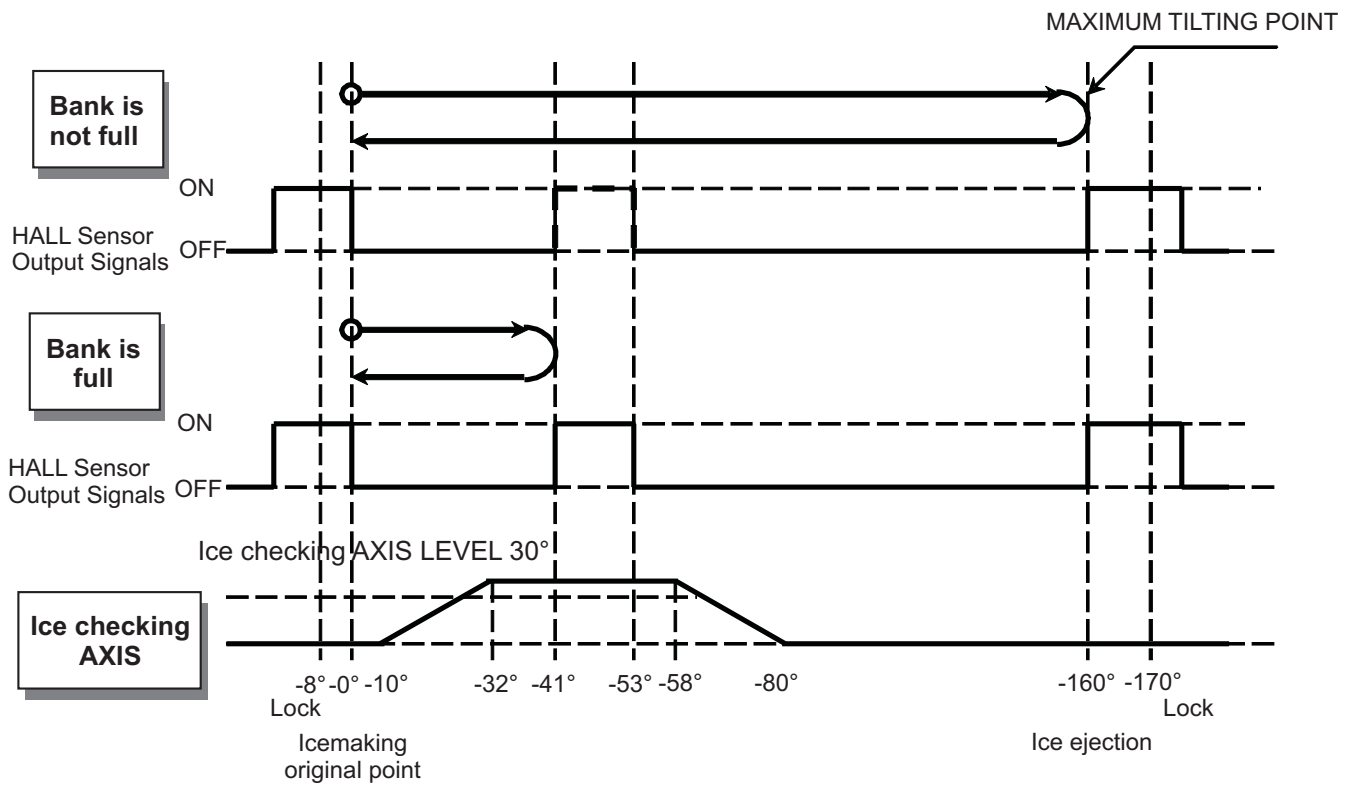

7-2-4 Test Icemaker Mode

Test function starts when test switch is pressed for more than **3 seconds**. User shouldn't force operation while doing test mode, service or cleaning.

Test switch will work only when ice tray its in horizontal position, not during ice ejection or water supplying.

When pressing the Test Switch, feeler arm will sense and then ice tray will start ice ejection, after twisting, ice tray returns to initial position. When returning to horizontal position, water supply will start filling the ice tray. After this, test mode its done.

Test mode cycle elapsed time of 30 seconds its shown as the next sequence:
 Feeler arm sensing – Ice ejecting – Ice tray returns to horizontal position – Water supply.

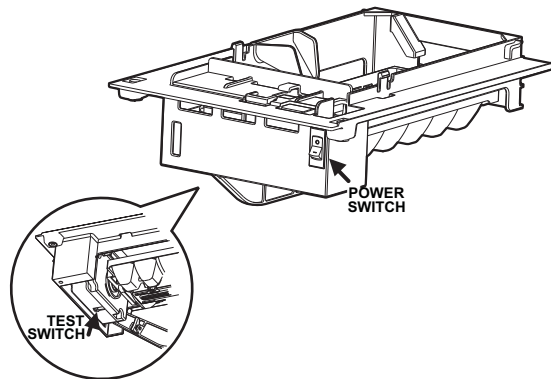

7-2-5 Water Supply Function

This function is for supply water to tray ,by the mechanic water valve ,when ice ejecting finish and tray return to initial position.

Water supply quantity depend of DIP S W.

Water Supply Time Table

No	DISP S/W		Water Supply Time	Note
	S1	S2		
1	OFF	OFF	9.0	DIP S/W Setting will be depend of water pressure
2	ON	OFF	8.0	
3	OFF	ON	10.0	
4	ON	ON	11.0	

If water supply setting is changed while system is energized, change will be made immediately. But if change occurs when water supply function is working, change will be executed next cycle of icemaker

7-2-6 Ice maker stop switch

- Ice Maker Stop S/W ON state, Ice Maker normal operation
- Ice Maker Stop S/W OFF state: Ice Maker do not operate

8. CIRCUIT OF MICOM

8-1 FUNCTION

8-1-1 Function

1. Initially set the Refrigerator control at 37°F (3°C) and the Freezer control at 0°F(-18°C)
You can adjust the Refrigerator and the Freezer control temperature by pressing the Colder ADJUST button.
2. When the power is restored after a power failure, it is automatically set to last setting selected.

*Note: To ERROR CODE on display panel refer to page 29.



8-1-2 How to Toggle the Display between °F & °C

1. The display temperature mode can be changed from °F to °C or °C to °F by pressing and holding the COLDER FREEZER TEMP and the COLDER REFRIGERATOR TEMP keys at the same time for over one second.
2. The initial setting is °F. Whenever the mode is changed, the appropriate LED is it.

8-1-3 Control of freezer fan motor

1. Freezer fan motor runs at either regular or high speed (2,400 or 2,700 rpm.)
2. High RPM is used when electricity is first on, for ULTRA ICE, and when refrigerator is overloaded. Standard RPM is used for normal usage.
3. The fan motor is stopped when refrigerator door is opened

8-1-4 ULTRA ICE

1. The purpose of this function is to intensify the cooling speed of freezer and to increase the amount of ice.
2. Whenever selection switch is pressed, selection/release, the LED will turn ON or OFF.
3. If there is a power outage and the refrigerator is powered on again, ULTRA ICE will be canceled.
4. To activate this function you need to press the ULTRA ICE key and the LED will turn ON. This function will remain activated for 24 hrs. The first three hours the compressor and Freezer Fan will be ON. The next 21hours the freezer will be controlled at the lowest temperature. After 24 hours or if the ULTRA ICE key is pressed again, the freezer will return to its previous temperature.
5. During the first 3 hours:
 - (1) Compressor and freezer fan (HIGH RPM) run continuously.
 - (2) If a defrost cycle begins during the first 90 minutes of ULTRA ICE , the ULTRA ICE cycle will complete its cycle after defrosting has ended. If the defrost cycle begins when ULTRA ICE has run for more than 90 minutes, ULTRA ICE will run for two hours after the defrost is completed.
 - (3) If ULTRA ICE is pressed during defrost, ULTRA ICE is on, this function will start seven minutes after defrost is completed and it shall operate for three hours.
 - (4) If ULTRA ICE is selected within seven minutes after compressor has stopped, the compressor (compressor delays seven minutes) will start after the balance of the delay time.
 - (5) The fan motor in the freezer compartment rotates at high speed during ULTRA ICE.
6. For the rest of 21 hours, the freezer will be controlled at the lowest temperature.

8-1-5. Refrigerator Lamp Auto Off

1. To protect the risk of lamp heat, when Refrigerator door opens for 7 min., refrigerator lamp is auto off.

8-1-6 Alarm for Open Door

1. This feature sounds a buzzer when the freezer or refrigerator door is not closed within 1 minute after it is opened.
2. One minute after the door is opened, the buzzer sounds three times each for 1/2 seconds. These tones repeat every 30 seconds.
3. The alarm is cancelled when the freezer or the refrigerator is closed while the buzzer sounds.

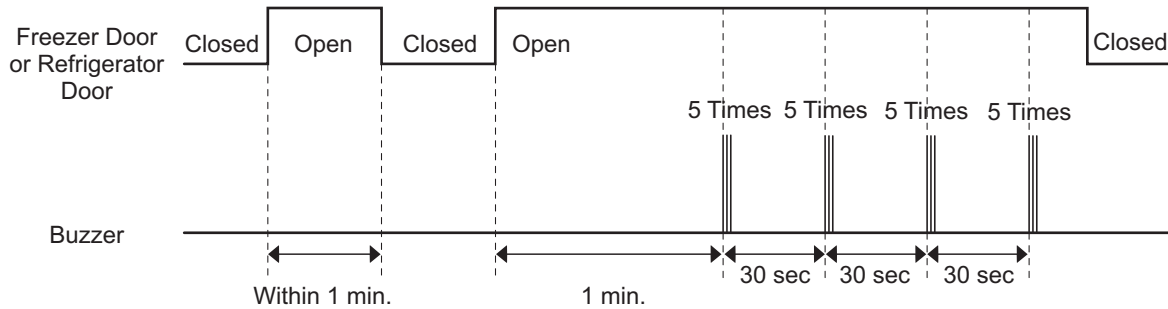

8-1-7 Buzzer Sound

When the button on the front Display is pushed, a sound is produced.

8-1-8 Defrosting (removing frost)

1. Defrosting starts each time the COMPRESSOR running time reaches 7 hours.
2. For initial power on or for restoring power, defrosting starts when the compressor running time reaches 4 hours.
3. Defrosting stops if the sensor temperature reaches 46.4°F(8°C) or more. If the sensor doesn't reach 46.4°F(8°C) in 2 hours, the defrost mode is malfunctioning. (Refer to the defect diagnosis function, 8-1-9.)
4. Defrosting won't function if its sensor is defective (wires are cut or short circuited)

8-1-9 Electrical Parts Are Turned On Sequentially

Electrical parts such as COMP, defrosting heater, freezer FAN, etc. are turned on in the following order to prevent noise and parts damage. Several parts are started at the same time at initial power on and are turned off together when TEST is completed.

OPERATING		ORDERS				
Initial power on	Temperature of Defrosting Sensor is 45°C or more (when unit is newly purchased or when moved)	POWER ON	in 1/2 second →	COMP ON	in 1/2 second →	Freezer FAN ON
	Temperature of defrosting sensor is lower than 45°C (when power cuts, SERVICE)	POWER ON	in 1/2 second →	Defrosting heater ON	in 10 second →	Defrosting heater OFF
		in 1/2 second →	COMP ON	in 1/2 second →	Freezer FAN ON	
Reset to normal operation from TEST MODE		Total load OFF	in 7 minute →	COMP ON	in 1/2 second →	Freezer FAN ON

8-1-10 Defect Diagnosis Function

Micom error are separated in “Main Errors” (Affect directly refrigerator performance) and “Secondary Errors” (don’t affect the refrigerator performance).

To check in Display the error present, is necessary press Cold key on freezer and Cold key on refrigerator more than 1 Second, if no there any error, all LED will be illuminated, if a main error is present, only certain LED will be illuminated, in case of secondary errors, only one LED or icon will not illuminated.



ERROR CODE on display panel

No.	Item	Error Indication		Contents	Remarks
1	Normal	NOTCH Indication		None	DISPLAY switch operates normally
2	Failure of Freezer sensor	Er	Fs	Cut or short circuit wire	Inspect Connecting wires on each sensor
3	Failure of Refrigerator sensor	Er	rS	Cut or short circuit wire	
4	Failure of Defrost sensor	Er	dS	Cut or short circuit wire	
5	RT-Sensor Error	Er	rt	Cut or short circuit wire	
6	Failure of Defrost mode	Er	dH	When defrost sensor does not reach 8°C within 1 hour after starting defrost.	Open defrost heater or temperature fuse, loose connection (indicated minimum 2h after a failure occurs)
7	Failura of BLDC fan motor at freezing compartment	Er	FF	If there is no fan motor signal for more than 115 sec in operation fan motor.	Motor failure, loose connection to fan motor, short circuit, or fan blade obstruction.
8	Failllure of Icemaker Kit	Er	It	Failure of wires such as motor in I/M KIT GEAR, HALL IC	When the ice ejecting does not operated on pressing the I/M TEST S/W
9	Failure of Icemaker sensor	Er	IS	Snapping or short circuit of ice making sensor	Connecting wire Test On Sensor

Primary Error: F sensor, R1 sensor, D sensor, Defrost errors, F-FAN errors.

Secondary Error: I / M sensors, I / M Kit, RT sensor.

When an error occur the first 3 hours the Primary Error and Secondary Error is indicated in the display check mode (Pressing Cold key on freezer and Cold key on refrigerator more than 1 Second). After the 3 hours and if the error is still present the Primary Error will show in the display automatically (See Note 1) and the Secondary Error is indicated in the display check mode.

Note 1: In the Primary Error after 3 hours of the error occur all display lights turn OFF except the Freezer Temperature (Trouble Code Index) indicating the failure mode.

*LED check function: When there’s no error, If simultaneously pressing the Cold key of refrigerator Temp and the Cold key of freezer temp for a second, all display LED graphics on. If releasing the button, the LED graphics displays the previous status.

Note 2: In Case of Icemaker ready models, discard Icemaker Sensor error until Icemaker kit will be connected.

8-1-11 TEST Mode

1. The Test mode allows checking the PCB and the function of the product as well as finding out the defective part in case of an error.
2. The test mode is operated by pressing two buttons on the Display panel.
3. While in the test mode, the function control button is not recognized, but the recognition tone (beep~) sounds.
4. After exiting the test mode, be sure to reset by unplugging and then plugging in the appliance.
5. If an error, such as a sensor failure, is detected while in the test mode, the test mode is cleared and the error code is displayed.
6. While an error code is displayed, the test mode will not be activated.

MODE	OPERATION	CONTENTS	REMARKS
TEST1	Push TEST switch (on the main Board) Once. <Cooling MODE>	<ol style="list-style-type: none"> 1. Continuous operation of the compressor and the freezer fan. 2. Stepping Damper OPEN 3. Defrosting Heater OFF 4. Display LED all ON 	Maximum test time: 5 minutes
TEST2	Push TEST switch once in TEST MODE 1. < Forced defrosting MODE>	<ol style="list-style-type: none"> 1. Compressor and the freezer fan OFF 2. Stepping Damper CLOSE 3. Defrosting heater ON 4. Display LED shows 2 	Maximum test time: 2 hours. Reset if the temperature Of the defrosting sensor is 8°C (46°F) or more.
Return to Normal	Push TEST switch on the main PCB once.	Return to initial status (COMP 7 min delay)	

* Freezer Fan RPM Variable Check:

If the freezer fan is in operation when the COLD REFRIGERATOR TEMP KEY & COLD FREEZER TEMP KEY are pressed for more than one second at the same time then the freezer fan RPM changes. (for example if high speed, to normal speed or if normal speed, to high speed for 30 seconds)

After 30 seconds, it turns to its original RPM.

* Demonstration (Display) MODE:

1. To enter this mode, raise either the Refrigerator or Freezer temperature to its highest setting. Then, press that Cold key and hold for about 5 seconds..
2. The LED panels will display OFF, to indicate that the compressor, circulating fan , damper, and defrost heater are not operating.
3. The Open Door Alarm and the Lamp Auto-Off feature will work normally and can be demonstrated.
4. To reset to normal operation, press and hold either Cold Key for about 5 seconds.

8-2 PCB FUNCTION

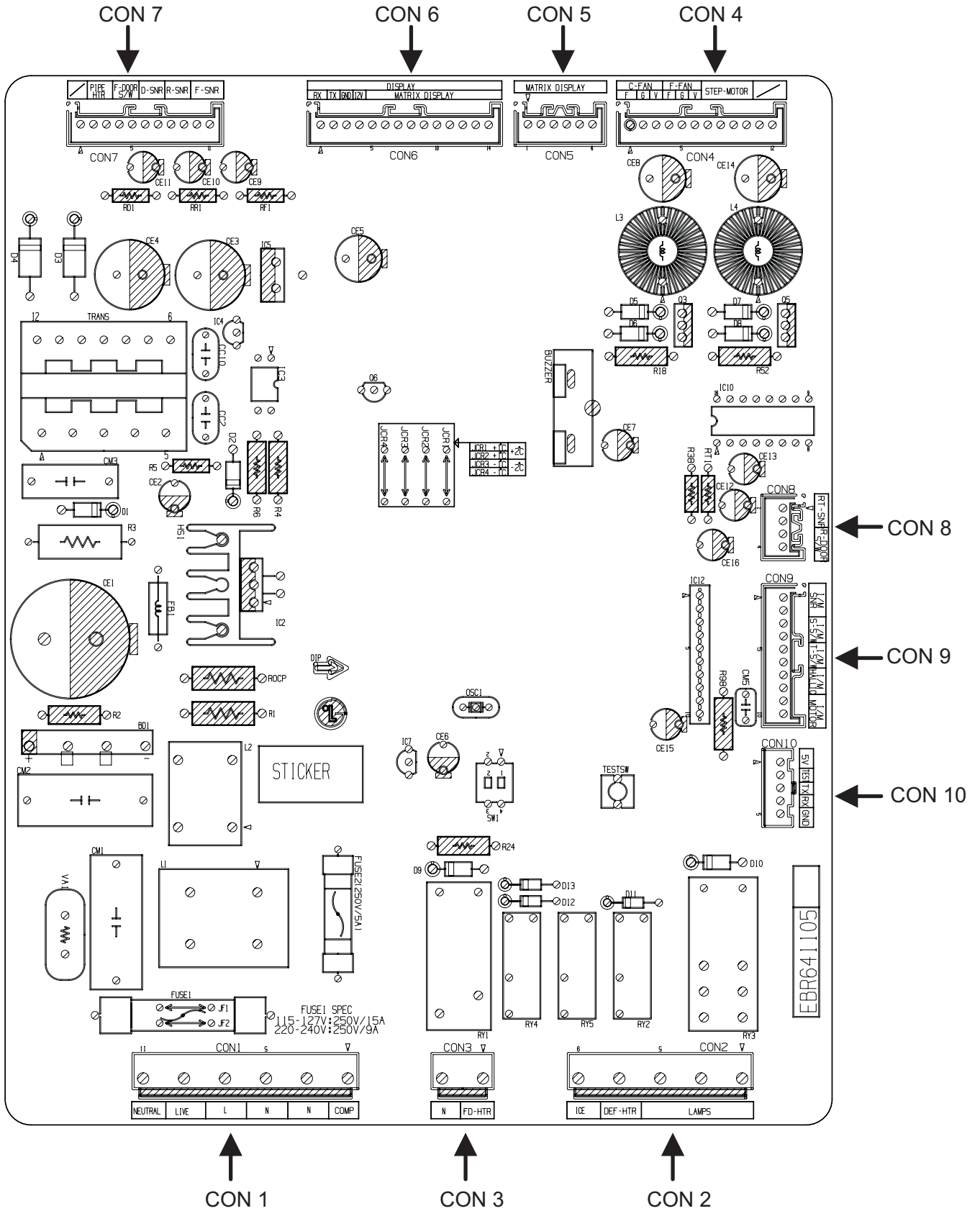

8-2-1 Power Circuit

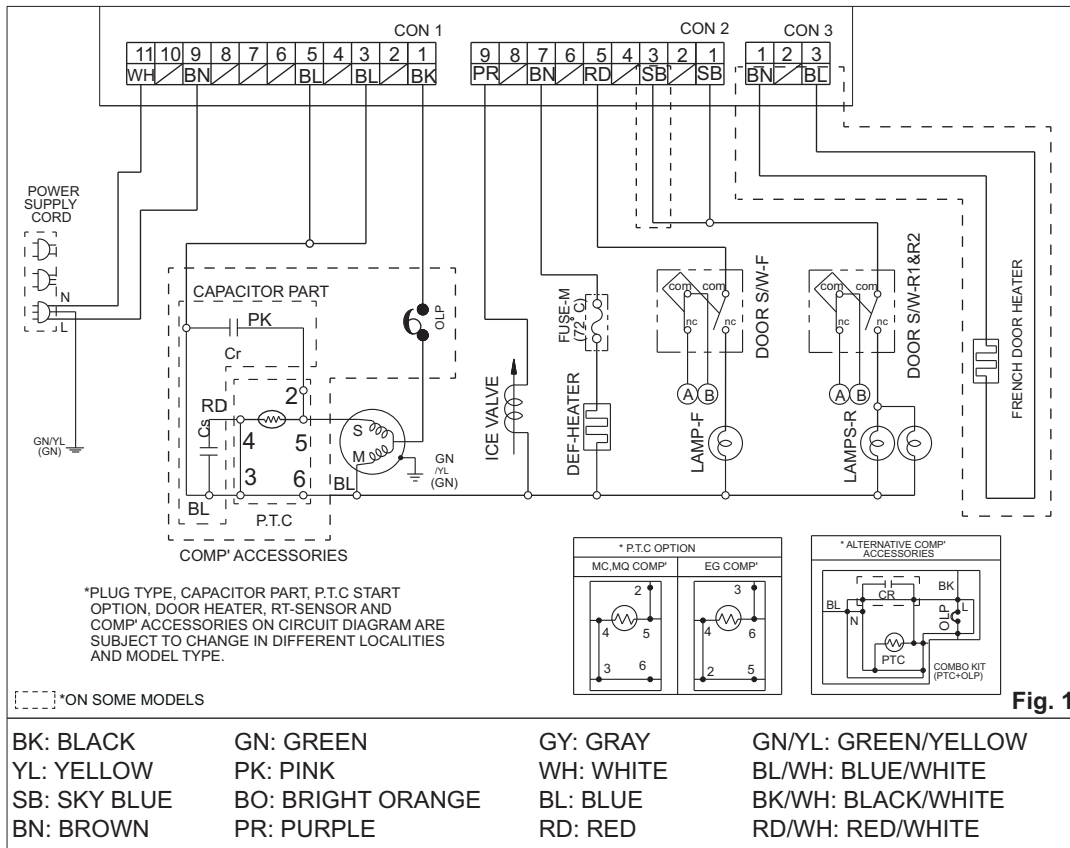

8-2-2. Load and Door Light Circuit (HV)

1. Load Drive Condition Check

To measure outputs of the control board, check voltages between the pins for the following components:
(Refer to Fig. 1).

Circuit	Pin Number	Pin Number	Output Voltage
Compressor	Con 1 Pin 1	Con 1 Pin 3	115 VAC
Defrost Heater	Con 2 Pin 7	Con 1 Pin 3	115 VAC
F Lamp	Con 2 Pin 5	Con 1 Pin 3	115 VAC
R Lamp	Con 2 Pin 1 and/or 3	Con 1 Pin 3	115 VAC
Ice Maker	Con 2 Pin 9	Con 1 Pin 3	115 VAC
French Door Heater	Con 3 Pin 1	Con 3 Pin 3	115 VAC

Connector 1				
Pin	11	9	3	1
	N	L	N	COMP

Connector 2					
Pin	9	7	5	3	1
	Ice Valve	Def Heater	F Lamp	R Lamp	

NOTE: When the door of the refrigerator is left open for 7 minutes or longer, the lamp of the refrigerator turns off automatically.

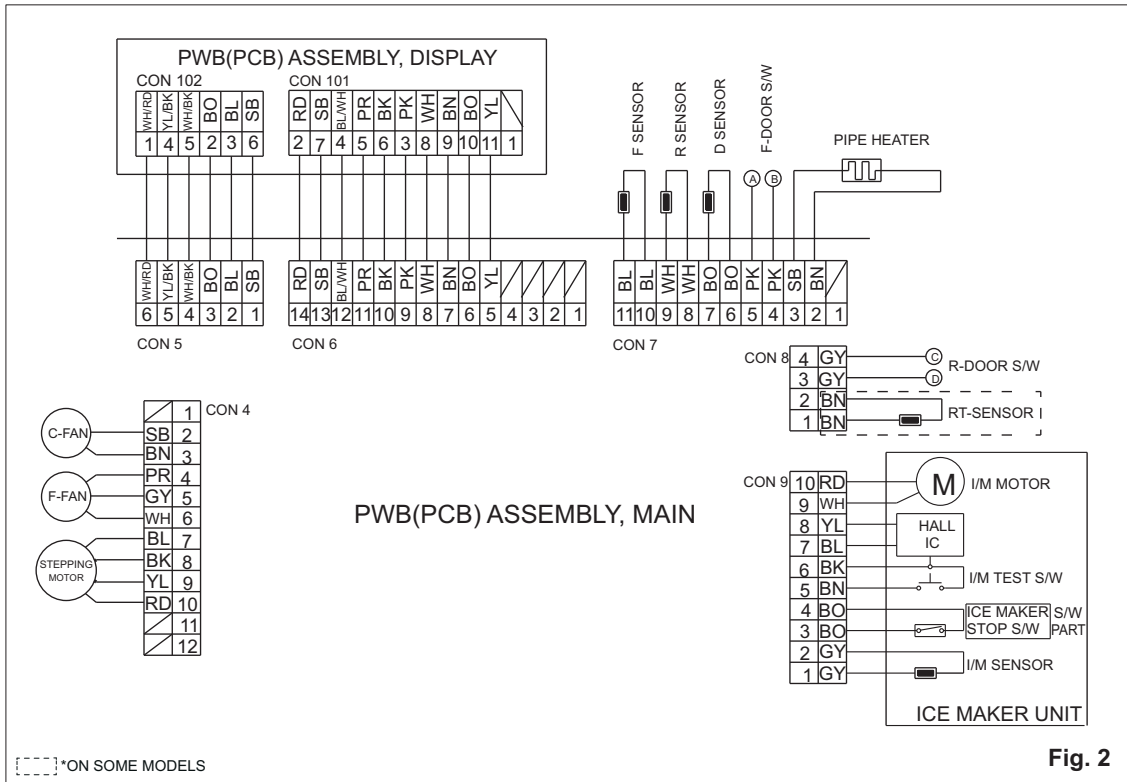

2. Door Monitor Circuit (LV)

Refrigerator	Pin Number	Pin Number	Voltage
F Door Close	Con 7 Pin 4	Con 7 Pin 5	5 Volts
F Door Open	Con 7 Pin 4	Con 7 Pin 5	0 Volts
R Door Close	Con 8 Pin 3	Con 8 Pin 4	5 Volts
R Door Open	Con 8 Pin 3	Con 8 Pin 4	0 Volts

Connector 8				
Pin	4	3	2	1
	R-Door S/W		RT- Sensor	

8-2-3 Temperature Sensor Circuit (Refer to Figure 2)

Voltage supplied to each sensor will range between 0.5 volts -22°F(-30°C) and 4.5 volts 122°F(50°C) depending upon the temperature in the compartments. A measurement of 0 volts indicates a short in the sensor circuit. A measurement of 5 volts indicates an open in the sensor circuit.

Connector 7											
PIN	11	10	9	8	7	6	5	4	3	2	1
	F-Sensor		R-Sensor		D-Sensor		F-Door S/W		Pipe Heater		NC

To measure the outputs of the sensors, check the voltages between the pins as in the table. And refer the values in the section "RESISTANCE SPECIFICATION OF SENSOR"

Sensor	Pin Number	Pin Number
F- Sensor	Con 7 Pin 10	Con 7 Pin 11
R- Sensor	Con 7 Pin 8	Con 7 Pin 9
D- Sensor	Con 7 Pin 6	Con 7 Pin 7
I/M Sensor	Con 7 Pin 1	Con 9 Pin 2
RT-Sensor	Con 8 Pin 1	Con 8 Pin 2

To measure the outputs of the fans on the control boards check the voltages between the pins for the following components:

FAN	Pin Number	Pin Number	Output Voltage	
			Motor On	Motor Off
Freezer Fan	Con 4 Pin 5	Con 4 Pin 6	10-14Vdc	2Vdc or less
Cooling Fan	con 4 Pin 2	Con 4 Pin 3	10-14Vdc	2Vdc or less

Connector 4												
PIN	12	11	10	9	8	7	6	5	4	3	2	1
	NC		Stepping Motor			F-Fan			C-Fan		NC	
	NC	NC					V	G	F	V	G	NC

8-2-4 ICE MAKER

Connector 9										
PIN	10	9	8	7	6	5	4	3	2	1
	I/M Motor		Hall IC		I/M Test S/W		I/M Stop S/W		I/M Sensor	

Circuit	Pin Number	Pin Number	Output Voltage
I/M Stop S/W	Con 9 Pin 3	Con 9 Pin 4	0~5Vdc
I/M Test S/W	Con 9 Pin 5	Con 9 Pin 6	0~5Vdc

8-3 RESISTANCE SPECIFICATION OF SENSOR

TEMPERATURE DETECTED SENSOR	RESISTANCE OF FREEZER SENSOR	RESISTANCE OF REFRIGERATOR DEFROST SENSOR & ROOM SENSOR
-20°C	22.3 KΩ	77 KΩ
-15°C	16.9 KΩ	60 KΩ
-10°C	13.0 KΩ	47.3 KΩ
-5°C	10.1 KΩ	38.4 KΩ
0°C	7.8 KΩ	30 KΩ
+5°C	6.2 KΩ	24.1 KΩ
+10°C	4.9 KΩ	19.5 KΩ
+15°C	3.9 KΩ	15.9 KΩ
+20°C	3.1 KΩ	13 KΩ
+25°C	2.5 KΩ	11 KΩ
+30°C	2.0 KΩ	8.9 KΩ
+40°C	1.4 KΩ	6.2 KΩ
+50°C	0.8 KΩ	4.3 KΩ

- The resistance of the SENSOR has a $\pm 5\%$ common difference.
- Measure the resistance of the SENSOR after leaving it for over 3 minutes in the measuring temperature. This delay is necessary due to sensor response speed.

9. EXPLODED VIEW

CASE PARTS

CAUTION: Use the part number to order part, not the position number.

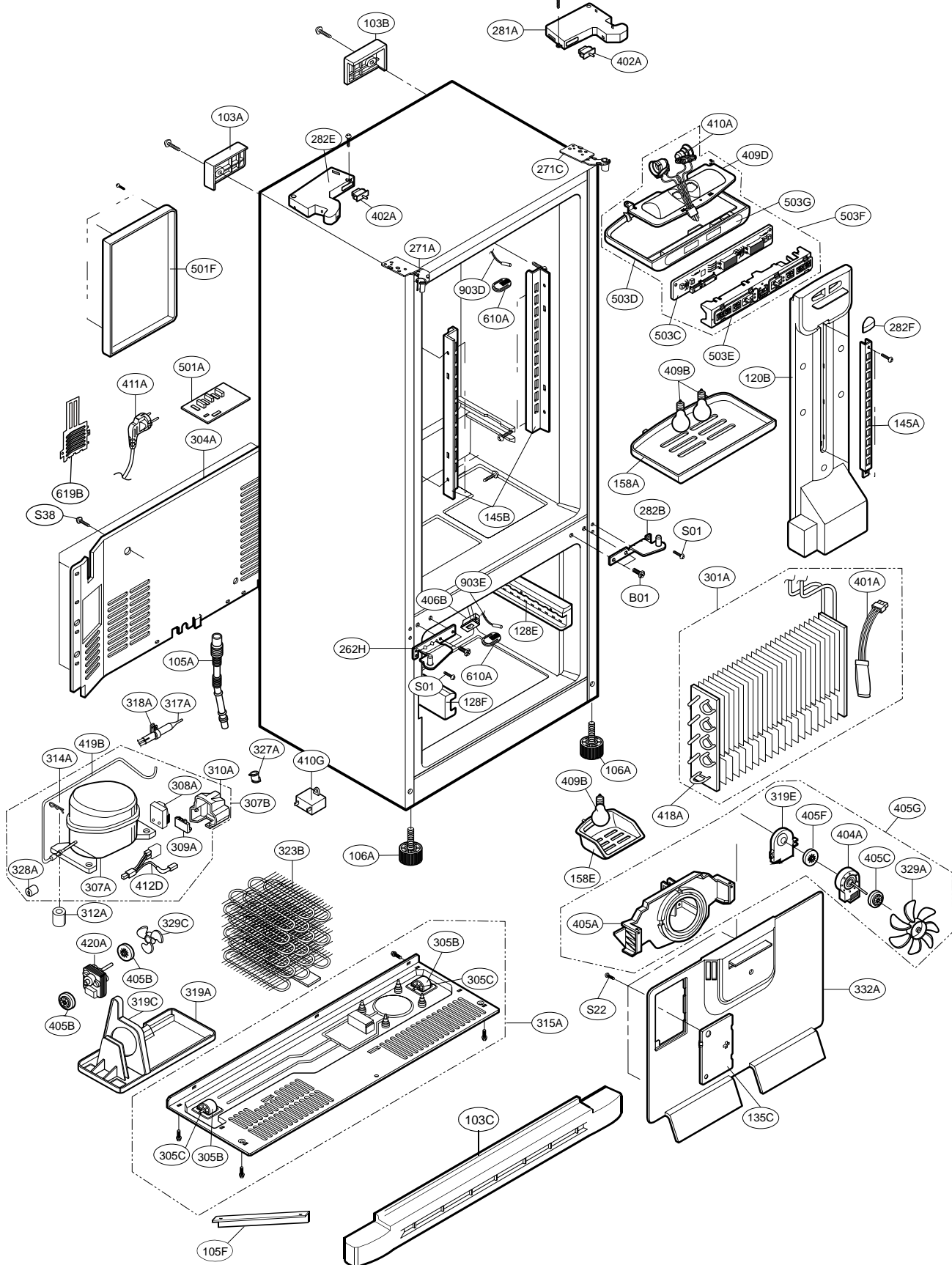

FREEZER PARTS

CAUTION: Use the part number to order part, not the position number.

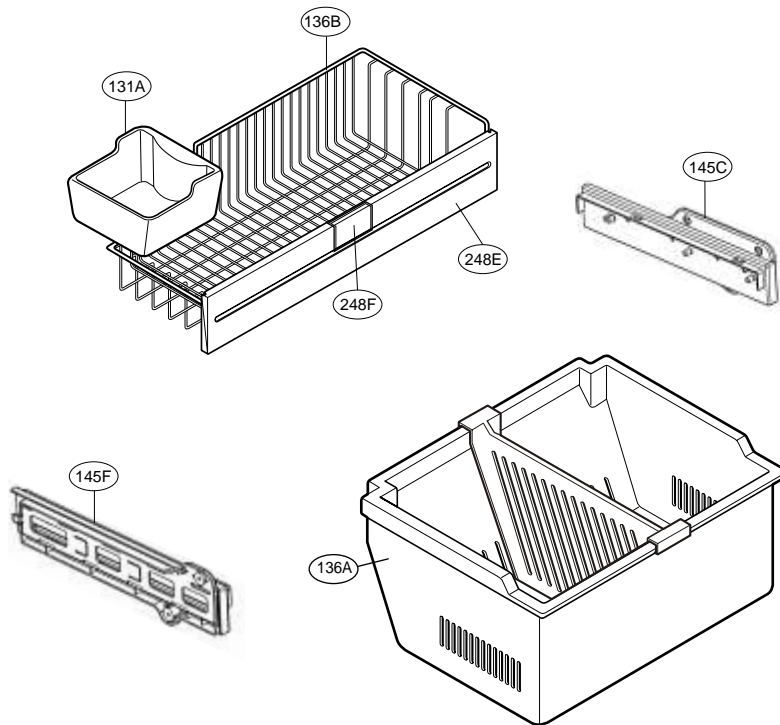

REFRIGERATOR PARTS

CAUTION: Use the part number to order part, not the position number.

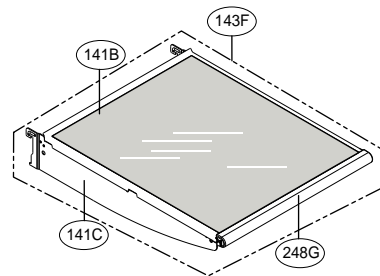
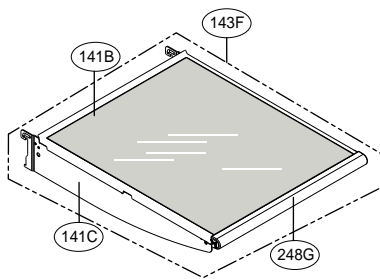
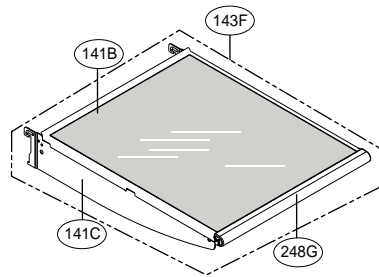
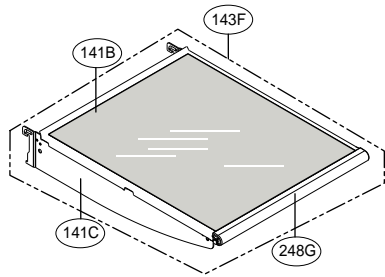
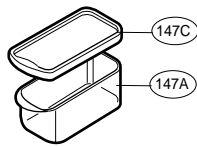

REFRIGERATOR PARTS (PANTRY)

Caution: Use the part number to order part, not the position number.

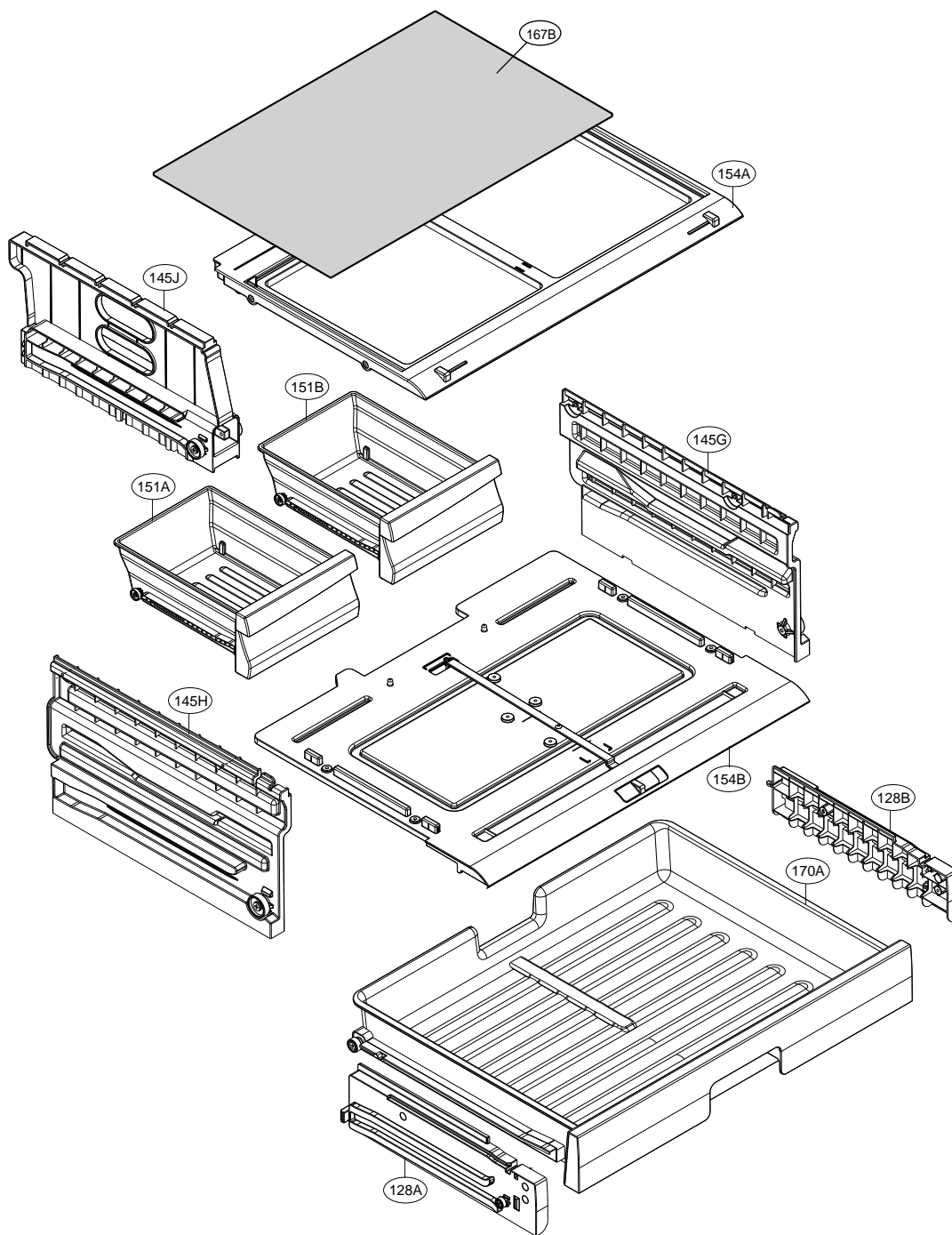

DOOR PARTS

CAUTION: Use the part number to order part, not the position number.

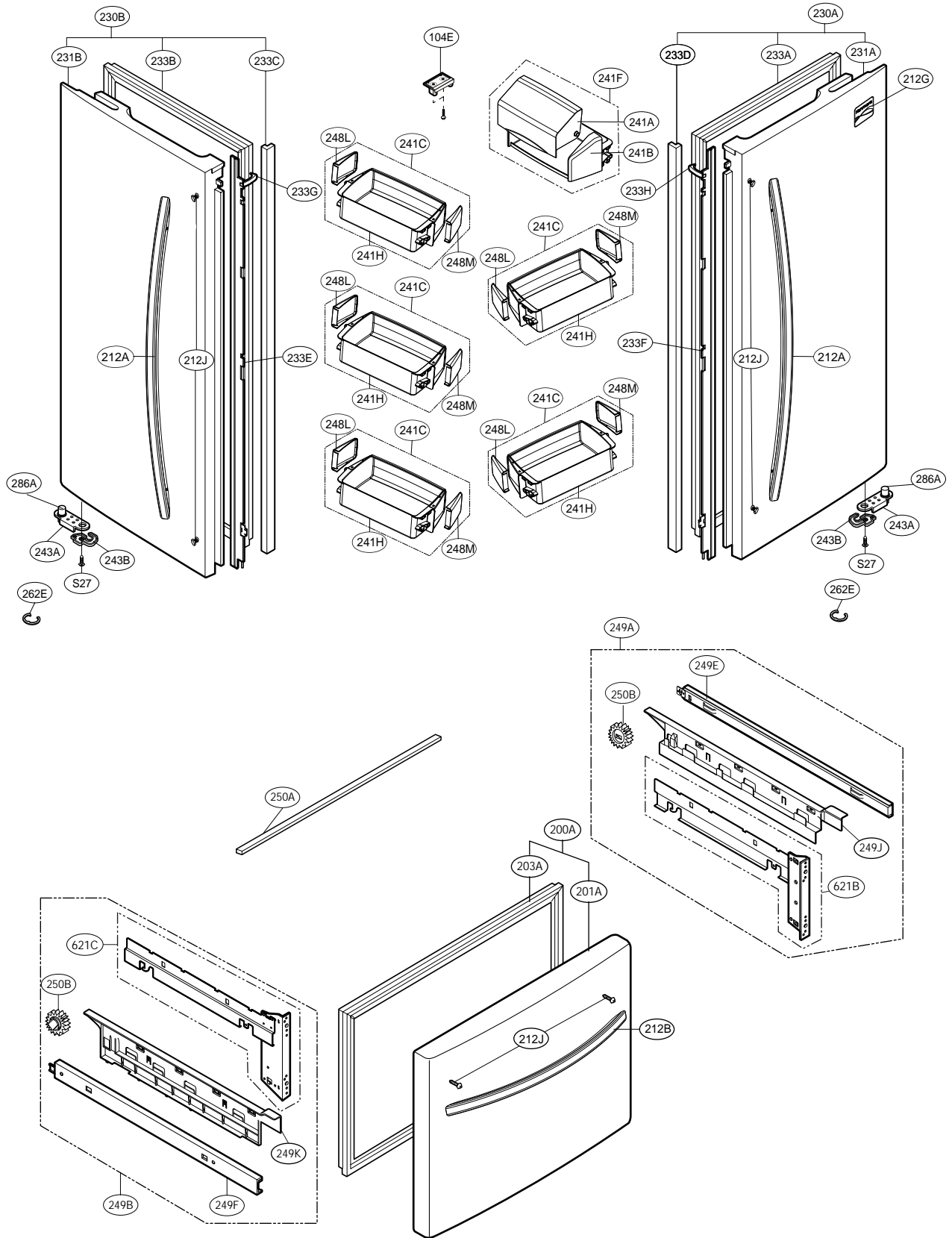

WATER & ICEMAKER PARTS

Caution: Use the part number to order part, not the position number.

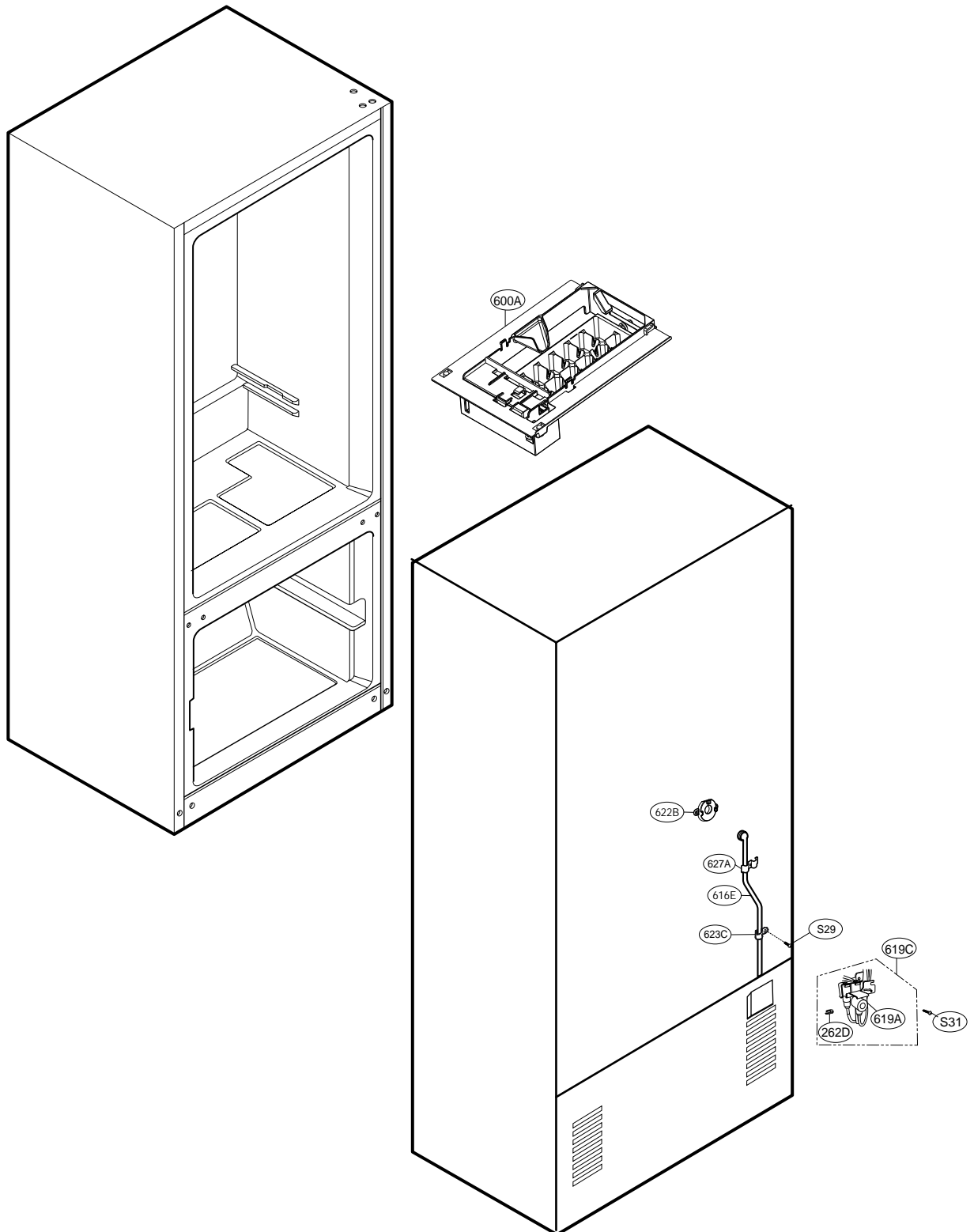

Get it fixed, at your home or ours!

Your Home

For expert troubleshooting and home solutions advice:

manage my home

www.managemyhome.com

For repair – **in your home** – of **all** major brand appliances, lawn and garden equipment, or heating and cooling systems, **no matter who made it, no matter who sold it!**

For the replacement parts, accessories and owner's manuals that you need to do-it-yourself.

For Sears professional installation of home appliances and items like garage door openers and water heaters.

1-800-4-MY-HOME[®]

(1-800-469-4663)

www.sears.com

Call anytime, day or night

(U.S.A. and Canada)

www.sears.ca

Our Home

For repair of carry-in items like vacuums, lawn equipment, and electronics, call anytime for the location of the nearest

Sears Parts & Repair Service Center

1-800-488-1222 (U.S.A.)

www.sears.com

1-800-469-4663 (Canada)

www.sears.ca

To purchase a protection agreement on a product serviced by Sears:

1-800-827-6655 (U.S.A.)

1-800-361-6665 (Canada)

Para pedir servicio de reparación a domicilio, y para ordenar piezas:

1-888-SU-HOGAR[®]

(1-888-784-6427)

Au Canada pour service en français:

1-800-LE-FOYER^{MC}

(1-800-533-6937)

www.sears.ca

Sears

© Sears Brands, LLC

® Registered Trademark / TM Trademark / SM Service Mark of Sears Brands, LLC

® Marca Registrada / TM Marca de Fábrica / SM Marca de Servicio de Sears Brands, LLC

^{MC} Marque de commerce / ^{MD} Marque déposée de Sears Brands, LLC