

This Owner's Manual is provided and hosted by [Appliance Factory Parts](#).



LG 75313 Owner's Manual

[Shop genuine replacement parts for LG 75313](#)



* The color vary in each model

[Find Your LG Refrigerator Parts - Select From 834 Models](#)

----- Manual continues below -----



TOP FREEZER REFRIGERATOR

REFRIGERATOR SERVICE MANUAL

CAUTION
BEFORE SERVICING THE UNIT,
READ THE SAFETY PRECAUTIONS IN THIS MANUAL.

MODELS:

795.75312.900

795.75313.900

795.75319.900

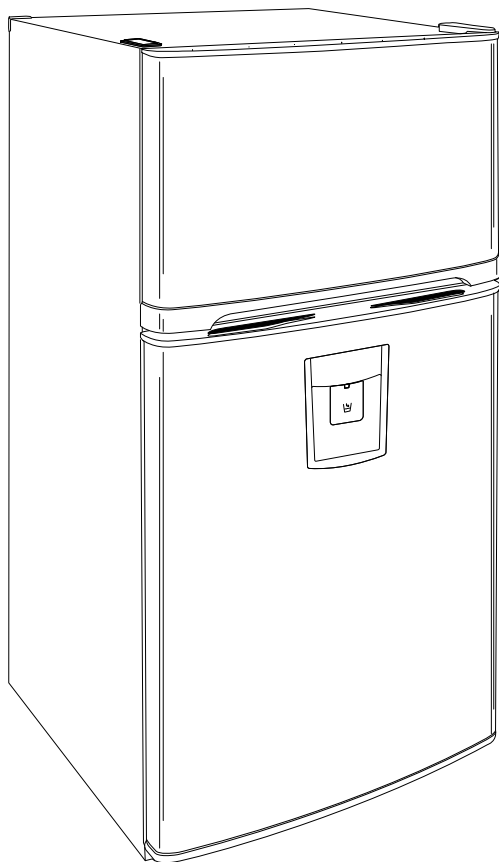

CONTENTS

SAFETY PRECAUTIONS	2
1. SPECIFICATIONS	3
2. PARTS IDENTIFICATION	5
3. DISASSEMBLY	6
3.1 Door	13
3.2 Fan and fan motor	13
3.3 Defrost control assembly	13
3.4 Lamp	13
3.5 Control box-refrigerator	13
4. COMPRESSOR ELECTRICAL	14
4.1 Compressor	14
4.2 PTC-Starter/ COMBO	14
4.3 OLP (overload protector)	15
5. CIRCUIT DIAGRAM	16
6. TROUBLESHOOTING	17
6.1 Compressor and electric components	17
6.2 PTC/ COMBO and OLP	18
6.3 Other electrical components	19
6.4 Service diagnosis chart	20
6.5 Refrigeration cycle	21
7. OPERATION PRINCIPLE AND REPAIR METHOD OF ICEMAKER	22
7.1 Operation principle	22
7.2 Ice maker functions	23
8. DESCRIPTION OF FUNCTION & CIRCUIT OF MICOM	24
8.1 Function	24
8.2 PCB function	29
8.3 Resistance specification of sensor	32
9. EXPLODED VIEW AND REPLACEMENT PART LIST	33

SAFETY PRECAUTIONS

Please read the following instructions before servicing your refrigerator.

1. Check the refrigerator for electrical faults.
2. To prevent electric shock, unplug before servicing.
3. Always check line voltage and amperage.
4. Use standard electrical components or cause your skin to freeze and stick to the surfaces inside the freezer.
5. Don't touch metal products in the freezer with wet hands. This may cause frostbite.
6. Prevent water from spilling onto electric elements or the machine parts.
7. Close the top door before opening the bottom door. Otherwise, you might hit your head when you stand up.
8. When tilting the refrigerator, remove any materials on the refrigerator, especially the glass shelves and stored food.
9. When servicing the evaporator, wear cotton gloves. This is to prevent injuries from the sharp evaporator fins.
10. Service on the refrigerator should be performed by a qualified technician. Sealed system repair must be performed by a CFC certified technician.

1. SPECIFICATIONS

1-1 DISCONNECT POWER CORD BEFORE SERVICING IMPORTANT RECONNECT ALL GROUNDING DEVICES.

All parts of this appliance capable of conducting electrical current are grounded. If grounding wires, screws, straps, clips, nuts or washers used to complete a path to ground are removed for service, they must be returned to their original position and properly fastened.

1-2 IMPORTANT NOTICE

This information is intended for use by individuals possessing adequate backgrounds of electrical, electronic and mechanical experience. Any attempt to repair a major appliance may result in personal injury and property damage. The manufacturer or seller cannot be responsible for the interpretation of this information, nor can it assume any liability in connection with its use.

1-3 ELECTRICAL SPECIFICATIONS

Temperature Control (Position: MID)	-6°F to +8°F
Defrost Control	Automatic
Defrost Thermostat	50°F
Electrical Rating: 115VAC, 60Hz	1-5.2A
Maximum Current Leakage	0.5mA
Maximum Ground Path Resistance	0.14Ohms
Energy Consumption22cuft 422KWh/yr (Energy star)

1-4 NO LOAD PERFORMANCE

Control Position: MID/MID

And ambient of:	70°F	90°F
Fresh Food, °F	33°F to 41°F	33°F to 41°F
Frozen Food, °F	-4°F to +4°F	-4°F to +4°F
Percent Running Time	25% - 35%	45% - 60%

1-5 REFRIGERATION SYSTEM

1-6 INSTALLATION

Minimum Compressor Capacity Vacuum 21 in
Minimum Equalized Pressure

Clearance must be provided at top, sides and rear of the refrigerator for air circulation.

@ 70°F	49PSIG	AT TOP	2in
@ 90°F	56PSIG	AT SIDES	2 in
Refrigerant R134a	5.47 Oz	AT REAR	2in
Compressor	700BTU/hr		

**PERFORMANCE DATA
(NORMAL OPERATING CONDITIONS)**

AMB	WATTS	SYSTEM PRESSURE (PSIG)	
		HIGH SIDE	LOW SIDE
70°F	98 (+10 / -10)	98 (+5 / -3)	(-5) to (-2)
90°F	98 (+10 / -10)	132 (+3 / -3)	(-4) to 1
110°F	103 (+5 / -5)	180 (+5 / -5)	(-2) to 3

1-7 REPLACEMENT PARTS

Relay (PTC)	6748C-0004D
Overload Protector (OLP)	6750C-0005P
Defrost Thermostat	4781JK2001A
Defrost Heater	5300JK1003J
Evaporator Fan Motor	4681JB1029J
Capacitor	0CZZJB2012J
Compressor (Hi-Side)	TCA33414101
Evaporator (Lo-Side)	5421JJ0002A
Condenser	5403JJ1008A
Dryer	5851JJ2002F
Temperature Control	6871JB2074F
Main Control	EBR41531308

1-8 AIR FLOW

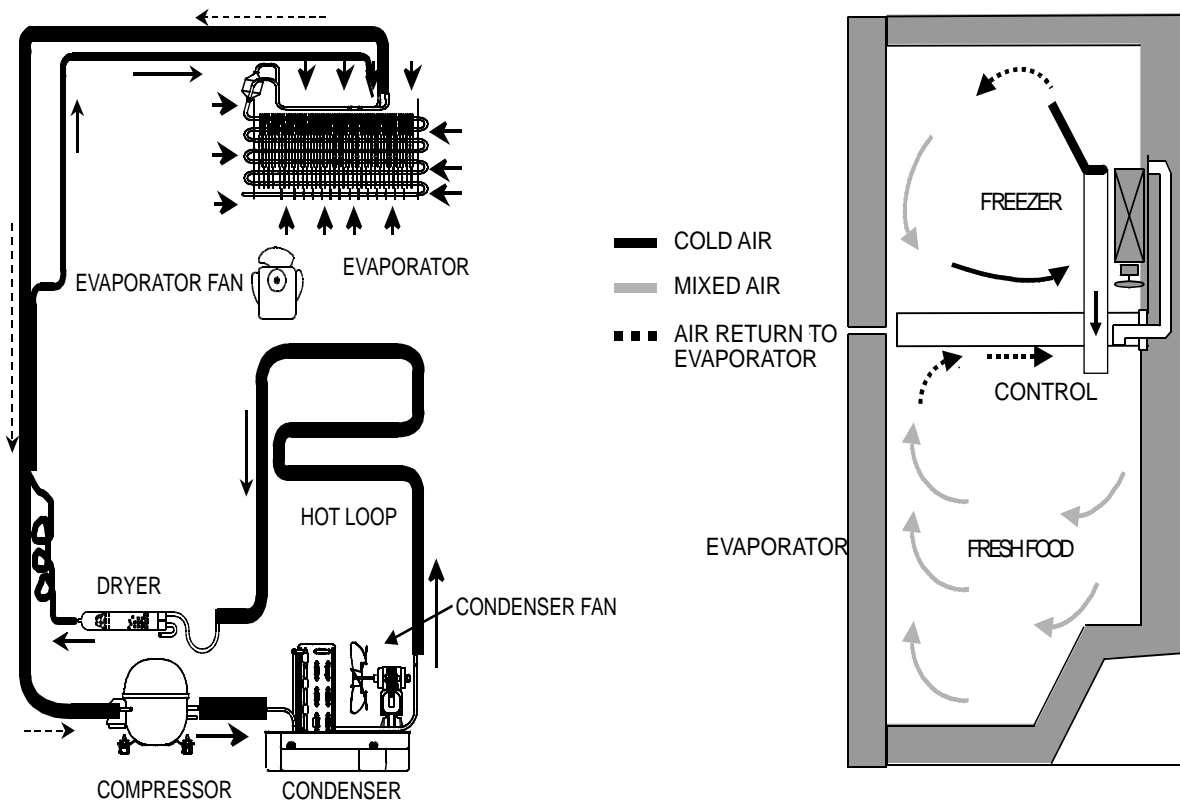

2. PARTS IDENTIFICATION

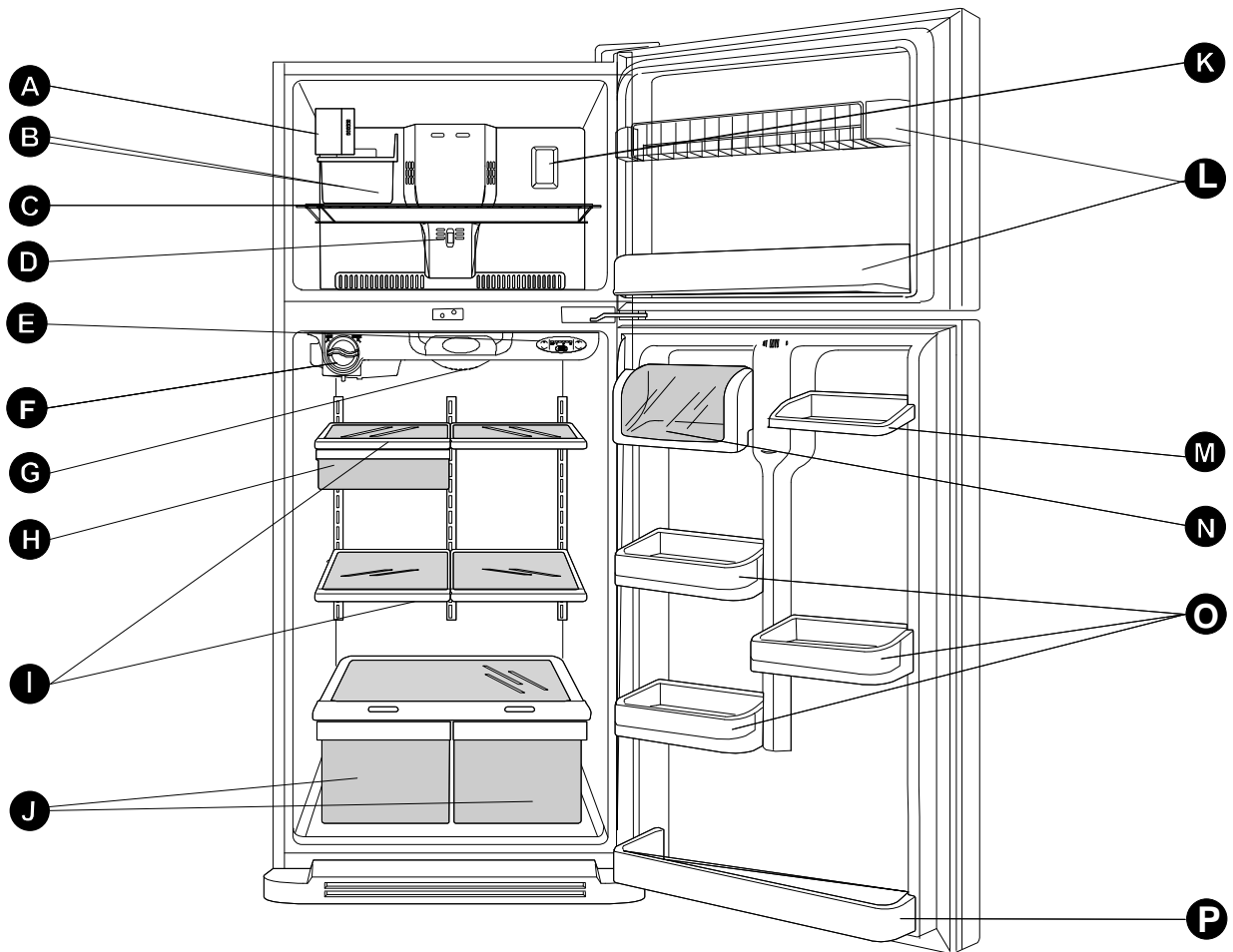

Use this section to become more familiar with the parts and features. Page references are included for your convenience.

NOTE: This guide covers several different models. The refrigerator you have purchased may have some or all of the items listed below. The locations of the features shown below may not match your model.

A CustomCube Ice maker *

B Ice Bin

C Freezer Shelf

D Freezer Temperature Control

E Refrigerator Temperature Control

F Water Filter

G Refrigerator Light

H Snack Drawer

I Shelves

J Crispers

Keeps fruits and vegetables fresh and crisp

K Freezer Light

L Freezer Door Racks

M Can Rack*

N Dairy Bin

O Door Bins

P Refrigerator Door Racks

* on some models

3. DISASSEMBLY

3-1 DOOR

Remove Freezer Door

Before removing the doors, remove the Base Grille.

1. Gently pry off the Top Hinge Cover with a flat head screwdriver and remove (see fig.1).

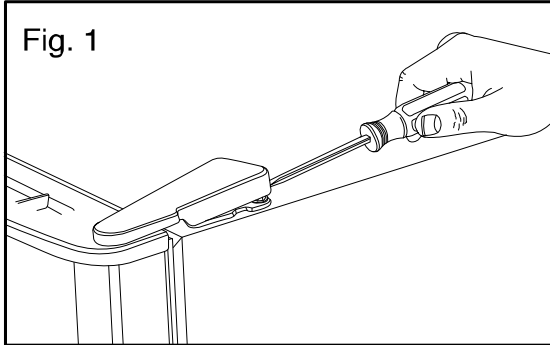

2. Using 10mm or 13/32-inch socket wrench, remove the bolts and lift off the Top Hinge (see fig.2). Set parts aside.

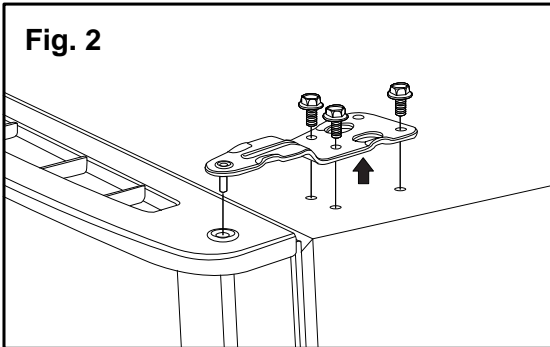

3. Lift freezer door slightly and remove it (fig.3). Set aside.

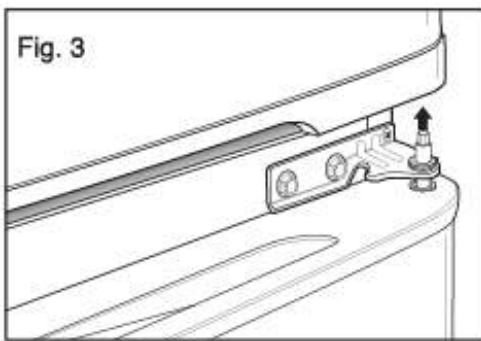

Remove Refrigerator Door

Locate the quick connector next to the Bottom Hinge and disassemble with the next steps:

1. Remove locking clip (1) and set aside.
2. Press back collet and pull out water connection tube (2).
3. Remove connector and set aside.

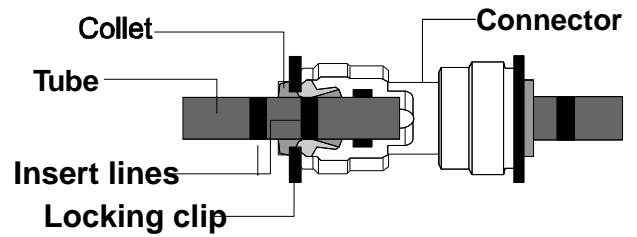
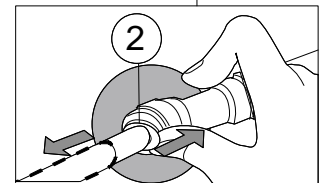
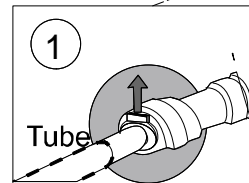
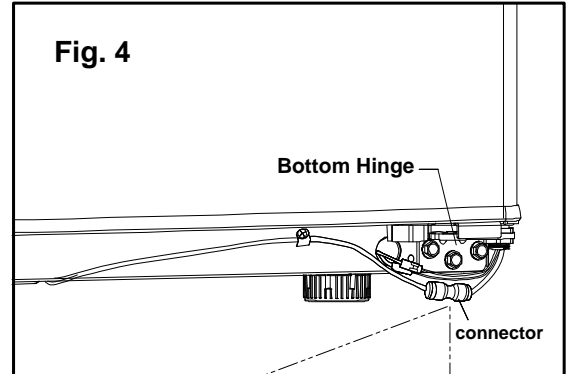

Carefully disconnect wire harness connectors next to Bottom Hinge.

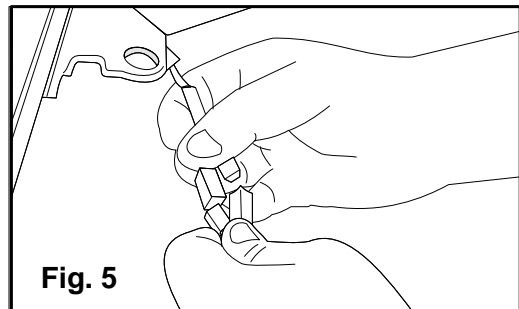

Using an adjustable wrench remove Bottom Nut.

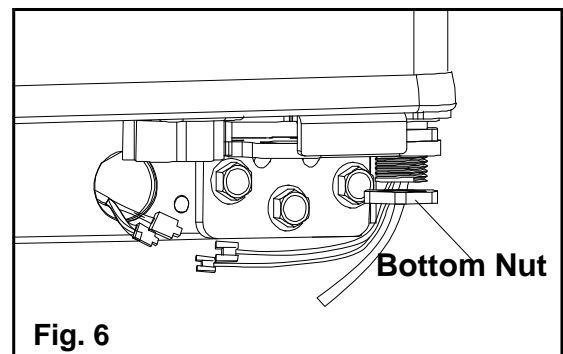

Loosen and remove the 2 bolts and the phillips head screw to remove the Middle Hinge Bracket from refrigerator cabinet (Fig.7 and 8). Set parts aside.

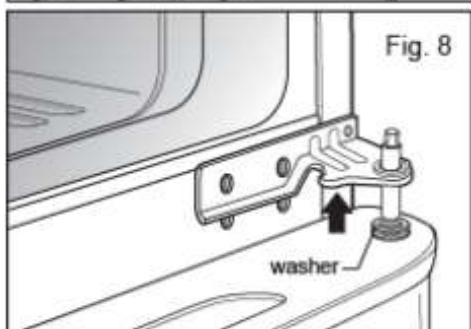
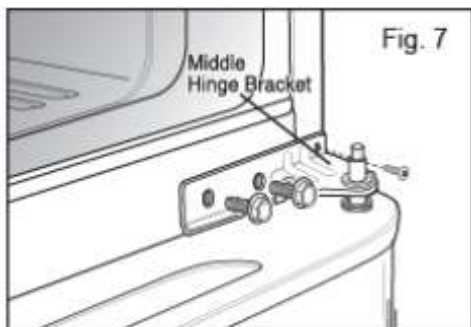

Lift up the door watching carefully that the wire harness and water tube don't get damaged by the bottom hinge.

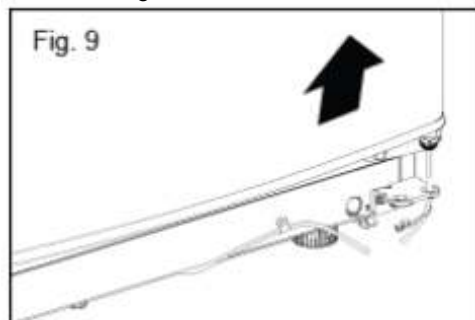

Replace Refrigerator Door

Insert the water tube and wire harness trough the bottom hinge. Being careful not to damage the water tube or wire harness, feed them trough the hole in the hinge plate.

Note: Make sure to align Hinge Pin with bottom hinge to assure proper assembly.

- Install the hinge pin into the bottom hinge.
- Using an adjustable wrench reinstall the bottom nut making sure it is tight.

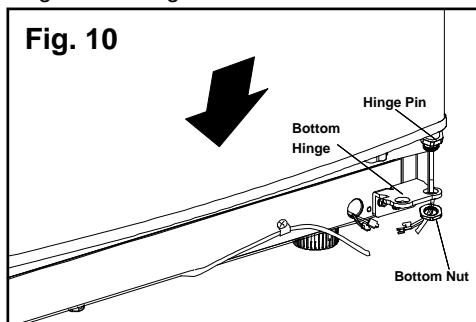

Reinstall the Middle Hinge with the two bolts and a phillips screw. Place washer between refrigerator door and middle hinge

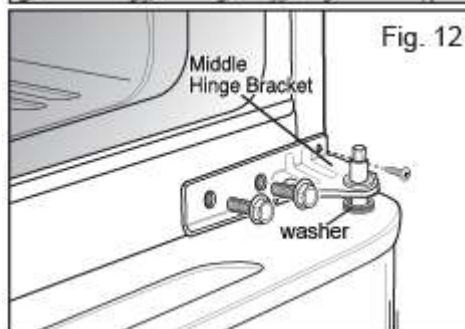
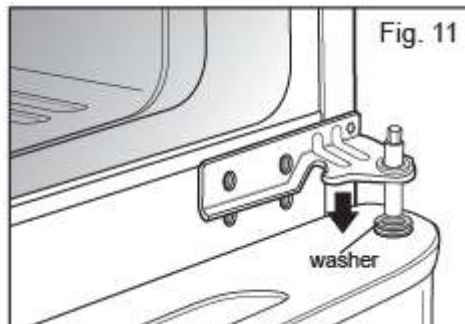

Once the refrigerator door is installed, reconnect wire harness, water tube and connector. There are two insert lines at the end of the tube. Insert the tube far enough into the connector until you can only see one line. Replace the locking clip.

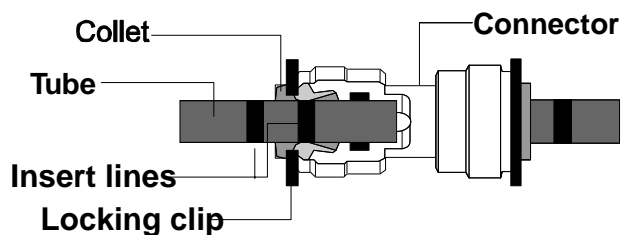
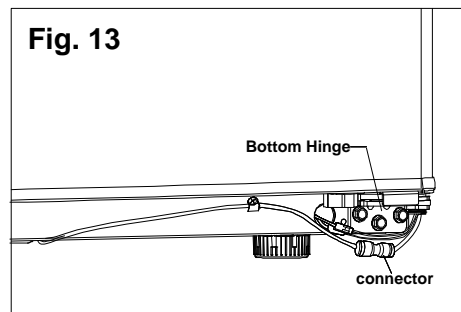

Replace Freezer Door

Set the freezer door onto the Middle Hinge Pin.

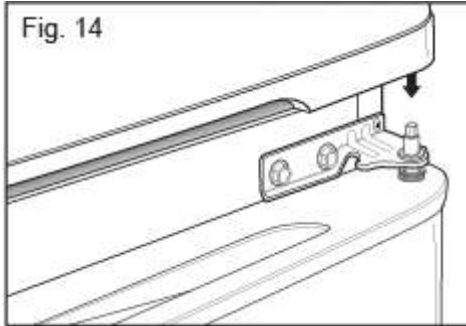

Place upper hinge pin in the top of freezer door and line up the upper hinge with holes in top of refrigerator. Use the 3 bolts to replace hinge.

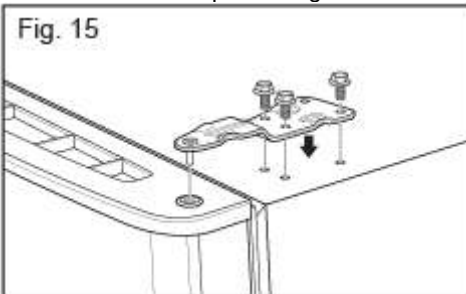

Carefully force-fit top hinge cover back into place over hinge.

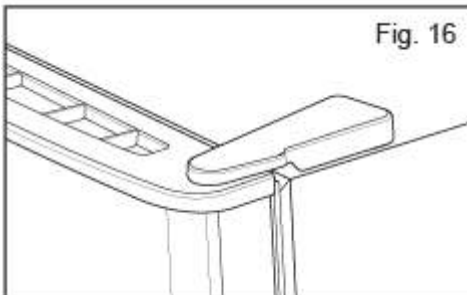

Reattach Base Grille when finished.

Reversing Doors

Tools needed

- 10mm or 13/32-inch socket wrench (with 2-inch extension for bottom door hinge)
- No.2 Phillips head screwdriver
- 1/4 inch socket wrench
- Flat-head screwdriver for prying
- Adjustable wrench

Reverse Freezer Door

Gently pry off the Top Hinge Cover with a flat head screwdriver and remove.

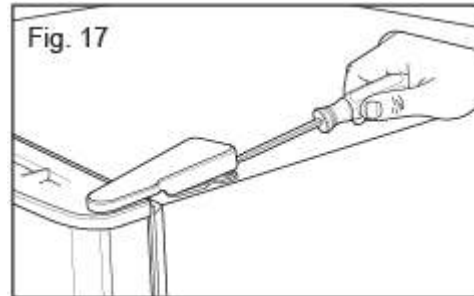

Using 10mm or 13/32-inch socket wrench, remove the 3 bolts and lift off the Top Hinge. Set parts aside.

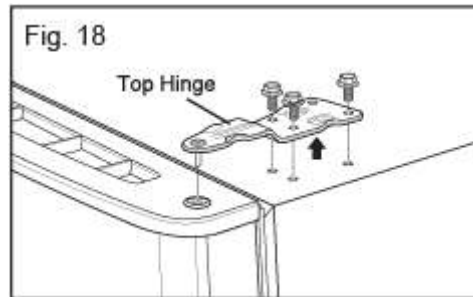

Lift up door slightly and remove it.

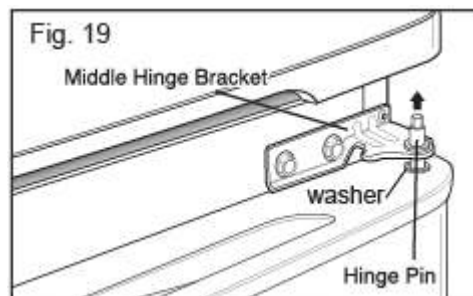

Turn freezer door upside down on a non-scratch surface and loosen the screw to remove Door Closer/Stop, Hinge Pin Insert and Hinge Pin Insert Bracket.

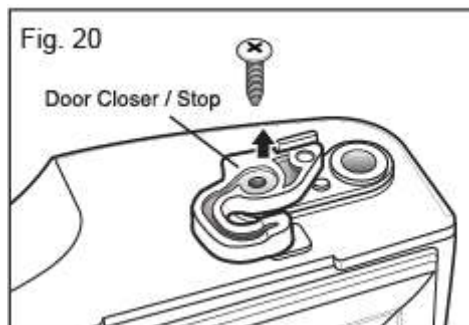

Move the Hinge Pin Insert Bracket to the other side of the door, keeping the same orientation, and move the Hinge Pin Insert into the hole on the left side of the bracket.

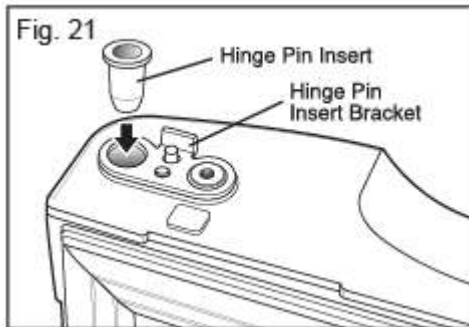

Reverse Door Closer/Stop by flipping over, place on top of Hinge Pin Insert Bracket, and tighten both down with the screw.

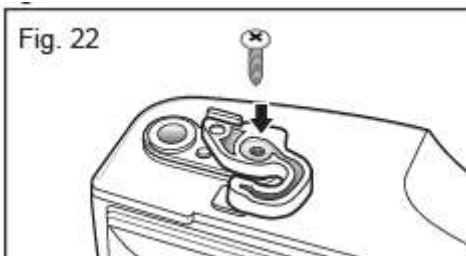

Pry off cover on top of refrigerator on left side to uncover screw holes.

Set freezer door and Top Hinge parts to the side and remove refrigerator door.

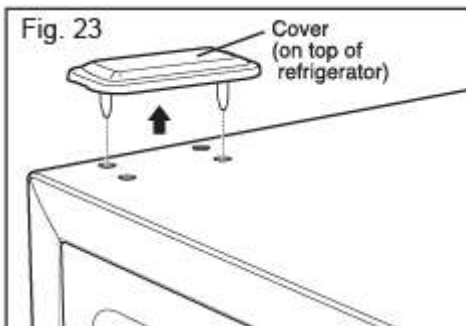

Reverse Refrigerator Door

Before reversing the door, remove the Base Grille.

Remove the cover on the left side of base grille and place it on the right side.

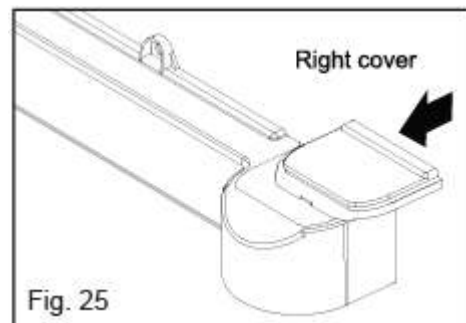
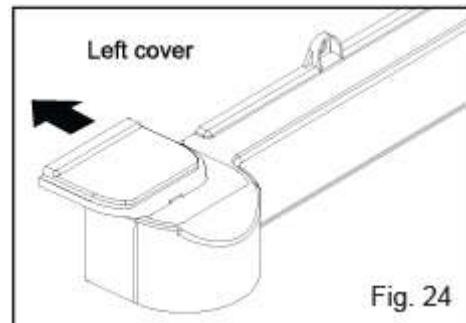

Locate the quick connector next to the Bottom Hinge and disassemble with the next steps:

1. Remove locking clip ① and set aside.
2. Press back collet and pull out water connection tube ②.

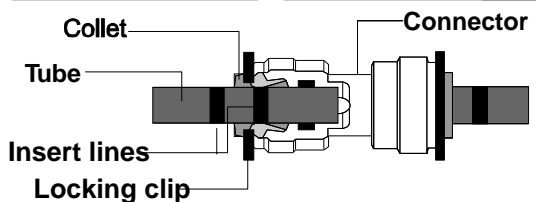
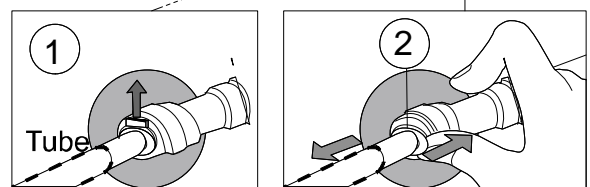
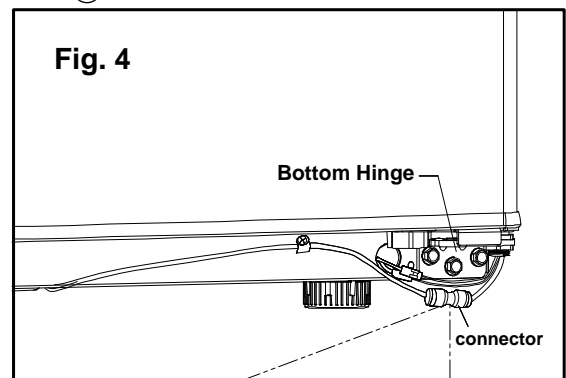

Carefully disconnect wire harness connectors next to Bottom Hinge. As described in **Remove Refrigerator Door**.

Using an adjustable wrench remove Bottom Nut. As described in **Remove Refrigerator Door**.

Insert flat blade screwdriver into corner notches on bottom of dispenser cover. Pry base off cover loose. CAREFULLY pull cover forward to detach clips on sides and top of cover, and disconnect the wire connector on the back of the dispenser cover. Set cover aside.

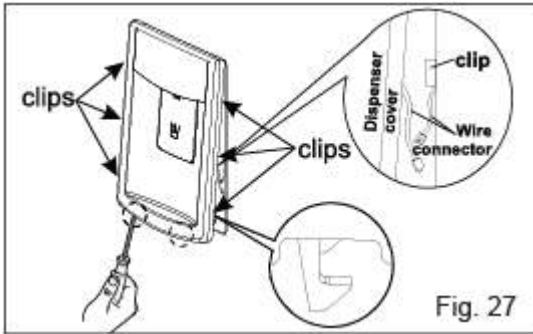

Use phillips screwdriver to remove tube guide screw. Pull tube all the way up and out of door. Set tube aside.

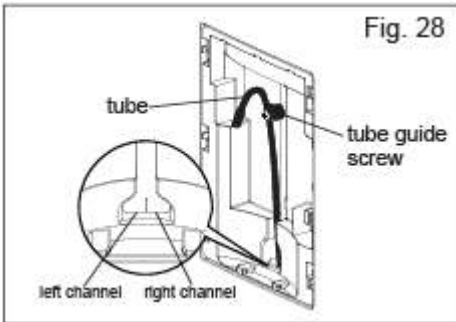

Using a 1/4" socket wrench, loosen and remove hinge pin from the middle hinge pin bracket. Remove washer underneath the middle hinge and set aside.

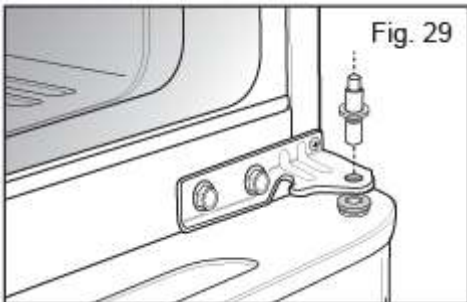

Lift up door watching carefully that wire harness doesn't get damaged by the Hinge Pin.

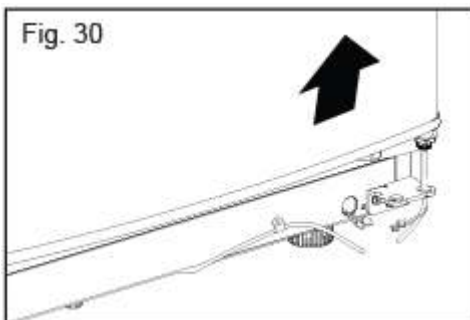

Using a 10mm or 13/32 inch socket wrench remove Middle hinge Bracket and set aside.

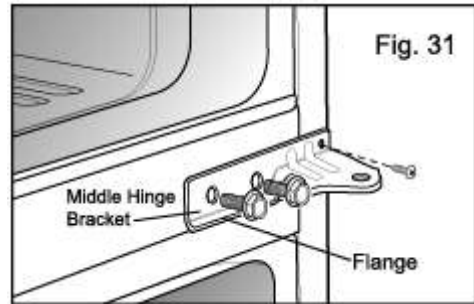

Using a 13/32" 10mm socket wrench with 2" extension, loosen the 3 bolts and remove bottom hinge from right side.

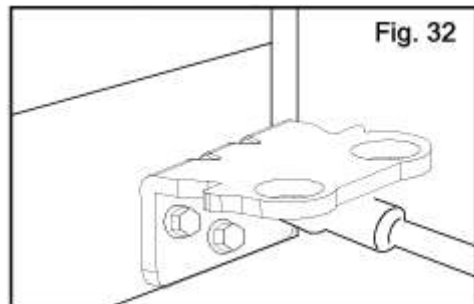

Remove the bolt on bottom of refrigerator from the left side and insert it on the right side. You will need this hole for the Bottom Hinge.

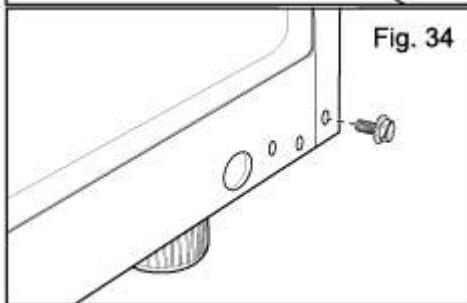
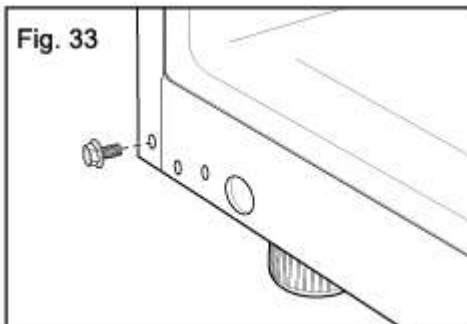

Move the Bottom Hinge to the left side keeping the same orientation and attach 3 bolts.

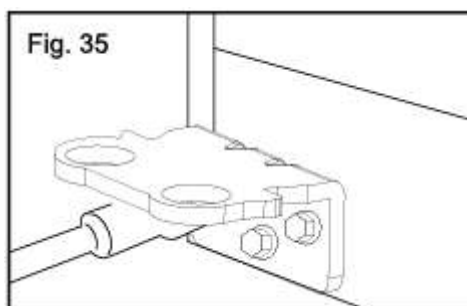

Remove screw from water tube clip.

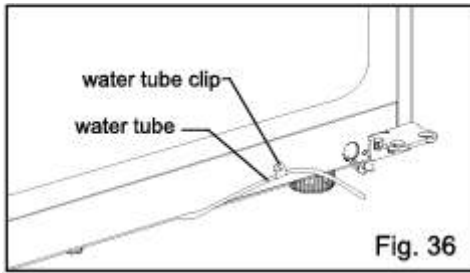

Reattach to the left side as shown below.

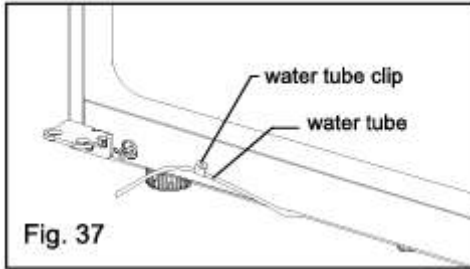

Important: Insert the wire harness into the base as shown below.

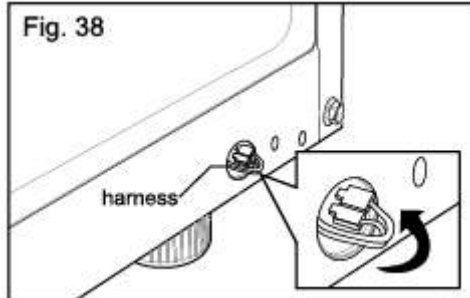

Turn refrigerator door upside down on a non-scratch surface and remove cap cover located on the left side using a flat-head screwdriver.

Then attach the cap cover on the opposite side. Cap cover is force fitted and holds the electrical harness.

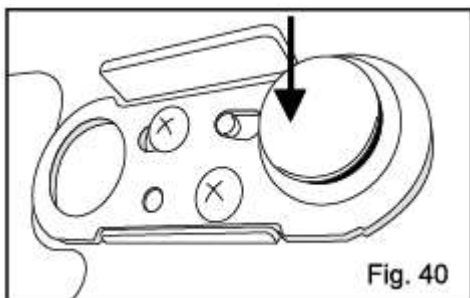
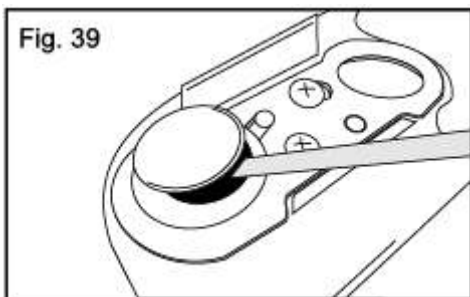

Loosen the 2 screws and remove the door Closer/Stop.

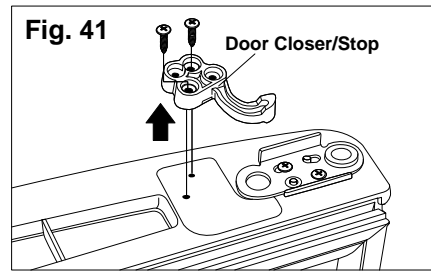

Take Door Closer/Stop and flip it over. Line up screw holes and screw it into left side of door bottom. Turn door upright. It is now ready for re-attaching.

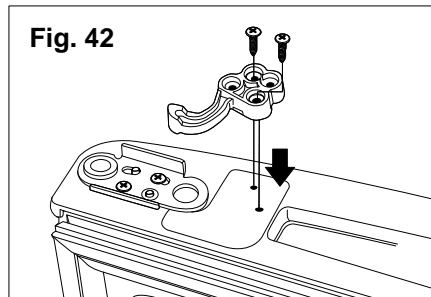

Insert the water dispenser tube into the left channel at the base of the dispenser cavity until it comes out of the bottom left corner of door.

Insert and reattach tube guide.

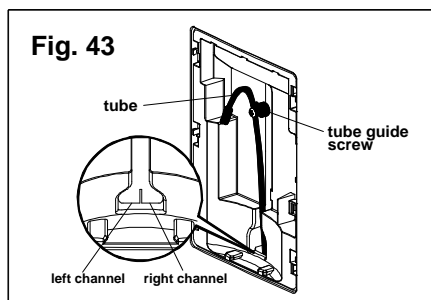

Reconnect the wire connector to the back of the dispenser cover, then insert the dispenser cover top clips into the slots in the top on the dispenser cavity. Make sure that the dispenser tube is lined up with the hole in the dispenser cover. Press against cover firmly to reattach.

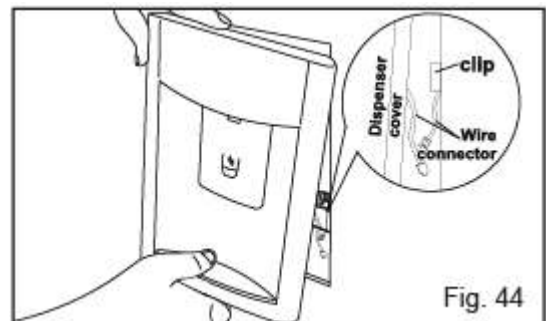

With a flat head screwdriver, carefully pry off and remove the cover over the screw holes on the left side of refrigerator housing.

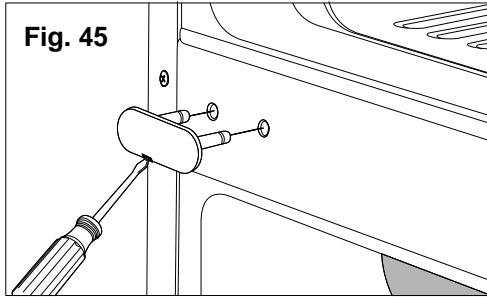

Remove the outer screw from cabinet at area between freezer and refrigerator doors. (You will need this hole for the Middle Hinge Bracket).

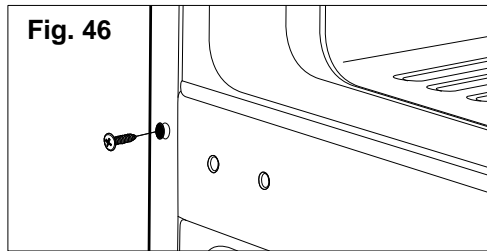

Place screw into outer hole on right side of cabinet. Attach cover on the right side. Cover is force-filled.

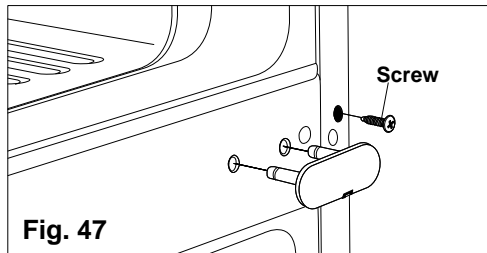

Flip the middle hinge bracket (flange now will be on top) and position on left side of refrigerator and re-attach with two bolts and phillips screw.

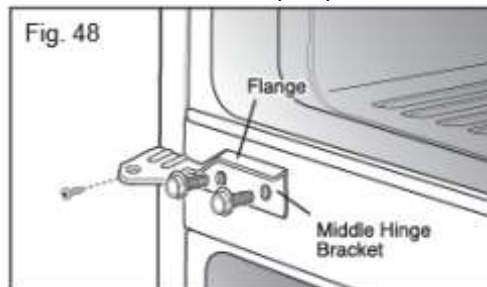

Pull the wire harness out from the base as shown below.

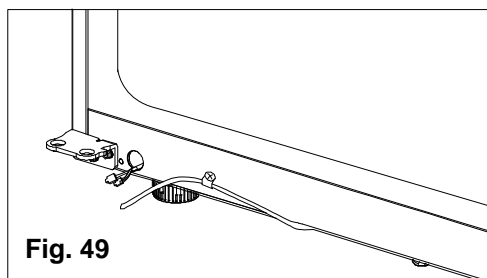

Insert the water tube and wire harness trough the bottom hinge pin and insert the pin into the bottom of the door. Note: Reinstall the Bottom Nut.

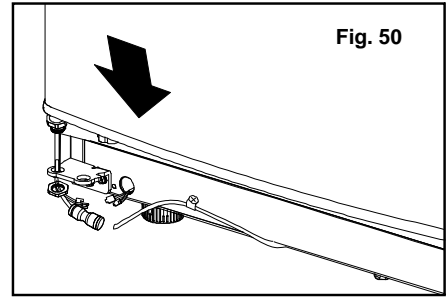

Place washer between refrigerator door and middle hinge and reattach hinge pin to hinge bracket with 1/4 in socket wrench.

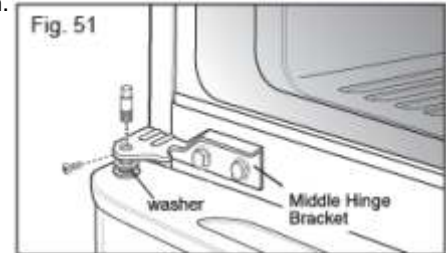

With the refrigerator door fully opened reconnect tube and connectors as described in Replace Refrigerator Door.

Put freezer door down over the Hinge Pin on the middle hinge pin bracket.

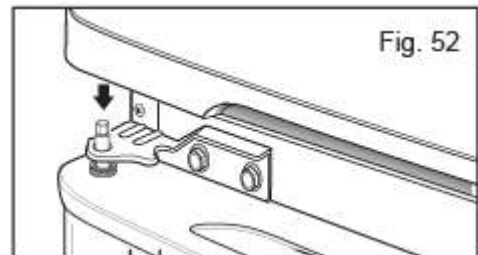

Place Top Hinge pin in the top of freezer door and line up the Top Hinge with holes in top of refrigerator.

Use the 3 bolts to replace the hinge.

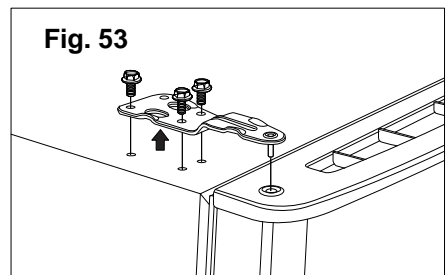

Tighten Bolts. Force-fit Top Hinge Cover over top Hinge.

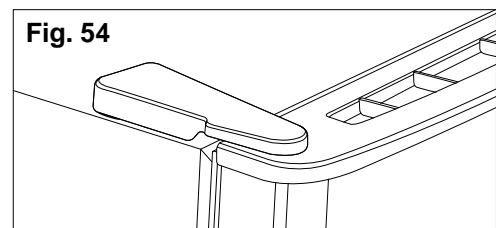

Replace cover from left side of refrigerator top onto the right of top to cover holes. Cover is also force-fitted.

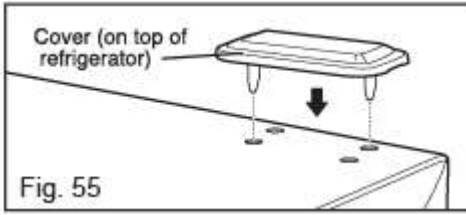

After changing doors, make sure that the corners of the Door Gaskets are not folded over. To ensure a good seal, apply a small amount of silicon grease on the corners of gaskets.

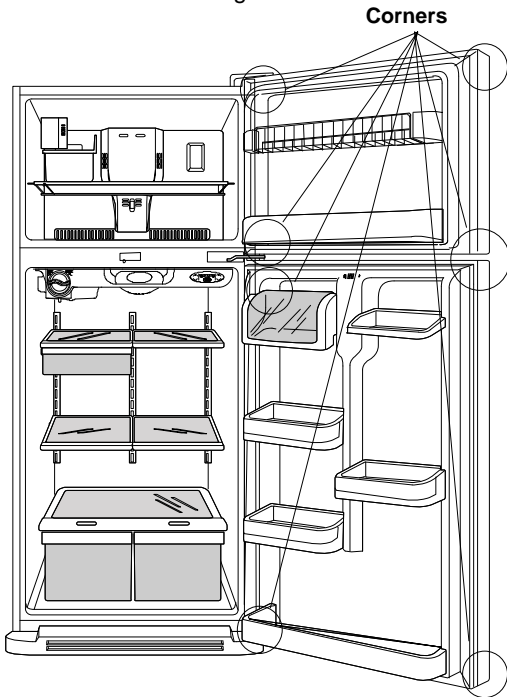

3-2 FAN AND FAN MOTOR

1. Remove the freezer shelf. (If your refrigerator has an icemaker, unplug and remove the icemaker first).
2. Remove the screw of the cover grille fan
3. Remove the grille by pulling it out and by loosening a screw.
4. Remove the Fan Motor assembly by loosening 4 screws and disassemble the shroud.
5. Pull out the fan and separate the Fan Motor and Bracket.

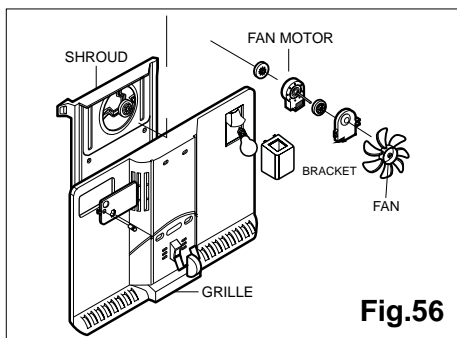

3-3 DEFROST CONTROL ASSEMBLY

Defrost Control assembly consists of Defrost Sensor and FUSE-M.

Defrost sensor functions to defrost automatically. It is attached to metal side of the Evaporator and senses Temperature. At the temperature of 162°F(72°C), it stops the emission of heat from the Heater.

Fuse-M is a safety device for preventing over-heating of the Heater when defrosting.

1. Pull out the grille assembly. (Figure 57)
2. Separate the connector of the Defrost Control assembly and replace the Defrost Control assembly after cutting the Tie Wrap. (Figure 58)

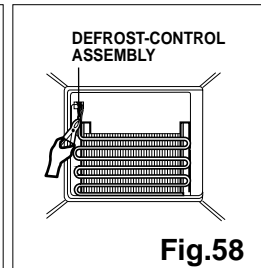
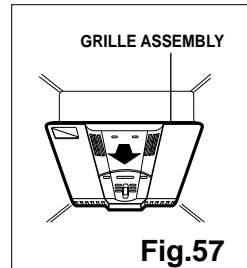

3-4 LAMP

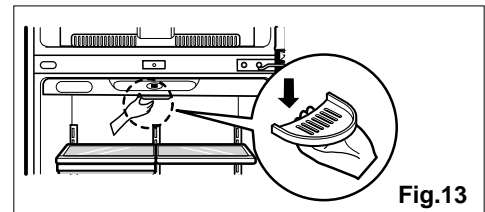

3-4-1 Refrigerator Compartment Lamp

1. Unplug the power cord from the outlet.
2. Remove refrigerator shelves.
3. Release the hooks on both ends of the lamp shield and pull the shield downward to remove it.
4. Turn the lamp counterclockwise.
5. Assemble in reverse order of disassembly. Replacement bulb must be the same specification as the original (Max. 40 W-1EA).

3-5 CONTROL BOX-REFRIGERATOR

1. First, remove all shelves in the refrigerator. Then remove the Refrigerator Control Box by loosening 2 screws.

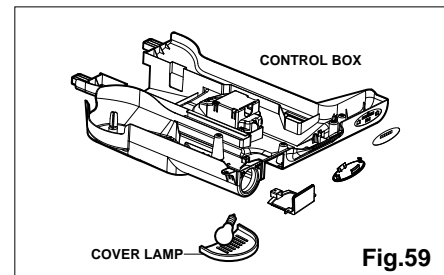

2. Remove the Refrigerator Control Box by pulling it downward.
3. Disconnect the lead wire on the right position and separate the lamp sockets.

4. COMPRESSOR ELECTRICAL

4-1 COMPRESSOR

4-1-1 Role

The compressor intakes low temperature and low pressure gas from the evaporator of the refrigerator and compresses this gas to high temperature and high pressure gas. It then delivers the gas to the condenser.

4-1-2 Composition

The compressor includes overload protection. The PTC starter and OLP (overload protector) are attached to the outside of the compressor. Since the compressor is manufactured to tolerances of 1 micron and is hermetically sealed in a dust and moisture-free environment, use extreme caution when repairing it.

4-1-3 Note for Usage

- (1) Be careful not to allow over-current.
- (2) If compressor is dropped or handled carelessly, poor operation and noise may result.
- (3) Use proper electric components appropriate to the particular compressor in your product.
- (4) Keep compressor dry.
If the compressor gets wet (in the rain or a damp environment) and rust forms in the pin of the Hermetic Terminal, poor operation and contact may result. If the hermetic connector rusts out or fails, refrigerant and oil will be expelled into the contact area, probably resulting in smoke and fire.
- (5) When replacing the compressor, be careful that dust, humidity, and soldering flux don't contaminate the inside of the compressor. Contamination in the cylinder may cause noise, improper operation or even cause it to lock up.

4-2 PTC-STARTER/COMBO

4-2-1 Composition of PTC- Starter

- (1) PTC (Positive Temperature Coefficient) is a no-contact semiconductor starting device which uses ceramic material consisting of BaTiO₃.
- (2) The higher the temperature is, the higher the resistance value. These features are used as a starting device for the motor.

4-2-2 Role of PTC-Starter

- (1) The PTC is attached to the Sealed Compressor and is used for starting the motor.
- (2) The compressor is a single-phase induction motor. During the starting operation, the PTC allows current flow to both the start winding and main winding.

4-2-3 Combo TSD

TSD (Time Starting Device) is a new electronic starting system for high efficiency compressors due to the following characteristics:

- (1) Combo concept-overload protector, electronic board and cover in a single casing.
- (2) Fully electronic concept.
- (3) Full integration of starting and protection devices.
- (4) Free from mechanical and electromagnetic noises.

4-2-4 Role of Combo TSD

- (1) The combo is attached to the sealed compressor and is used for the operation and protect the motor.
- (2) The compressor is a single phase induction motor. During the starting and operation, the combo allows current flow to both the start and main winding.

4-2-5 PTC/Combo - Applied Circuit Diagram Starting Method for the Motor

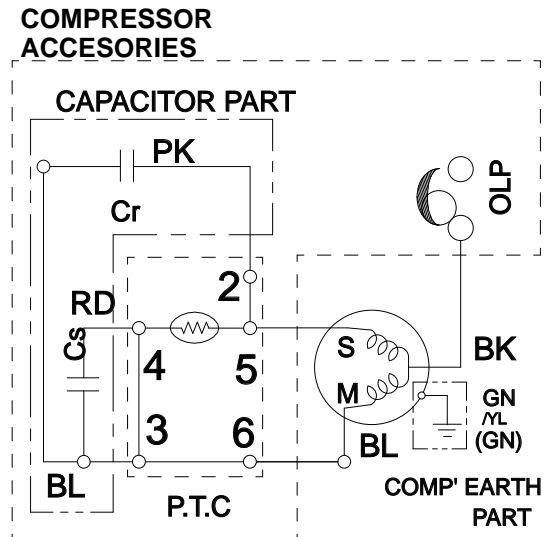

PTC DIAGRAM

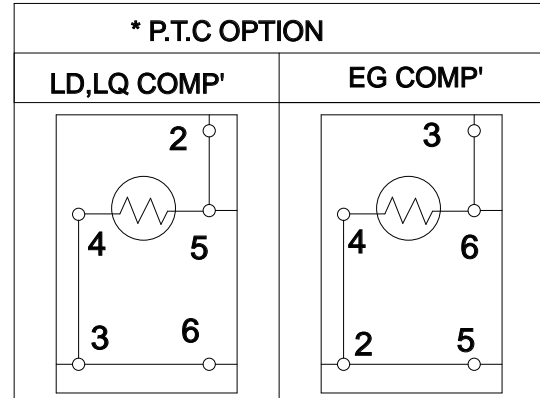

COMBO KIT DIAGRAM

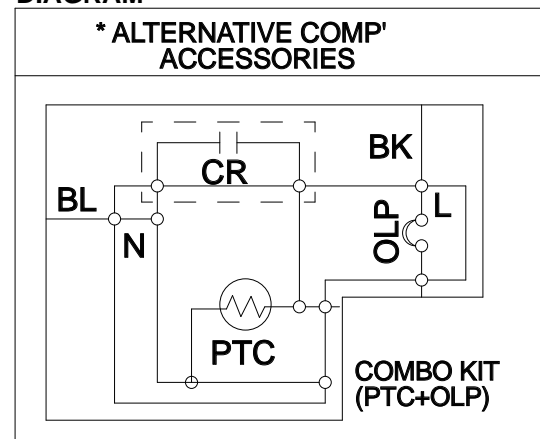

4-2-6 Motor Restarting and PTC/Combo Cooling

- (1) It requires approximately 5 minutes for the pressure to equalize before the compressor can restart.
- (2) The PTC/Combo device generates heat during operation. Therefore, it must be allowed to cool before the compressor can restart.

4-2-7 Relation of PTC-Starter / Combo and OLP

- (1) If the compressor attempts to restart before the PTC/Combo device is cooled, the PTC/Combo device will allow current to flow only to the main winding.
 - (2) The OLP will open because of the over current condition. This same process will continue (3 to 5 times) when the compressor attempts to restart until the PTC/Combo device has cooled. The correct OLP must be properly attached to prevent damage to the compressor.
- Parts may appear physically identical but could have different electrical ratings. Replace parts by part number and model number. Using an incorrect part could result in damage to the product, fire, injury, or possibly death.

4-2-8 Note for using the PTC-Starter / Combo

- (1) Be careful not to allow over-voltage and over-current
 - (2) Do not drop or handle carelessly.
 - (3) Keep away from any liquid.
- If liquid such as oil or water enters the PTC/Combo, PTC/Combo materials may fail due to breakdown of their insulating capabilities.
- (4) If the exterior of the PTC/Combo is damaged, the resistance value may be altered. This can cause damage to the compressor and result in a no-start or hard-to-start condition.
 - (5) Always use the PTC/Combo designed for the compressor and make sure it is properly attached to the compressor. Parts may appear physically identical but could have different electrical ratings. Replace parts by part number and model number. Using an incorrect part could result in damage to the product, fire, injury, or possibly death.

4-3 OLP (OVERLOAD PROTECTOR)

4-3-1 Definition of OLP

- (1) OLP (OVERLOAD PROTECTOR) is attached to the compressor and protects the motor by opening the circuit to the motor if the temperature rises activating the bimetal spring in the OLP.
- (2) When high current flows to the compressor motor, the bimetal works by heating the heater inside the OLP, and the OLP protects the motor by cutting off the current flowing to the compressor motor.

4-3-2 Role of the OLP

- (1) The OLP is attached to the sealed compressor used for the refrigerator. It prevents the motor coil from being started in the compressor.
- (2) For normal operation of the OLP, do not turn the adjust screw of the OLP in anyway.

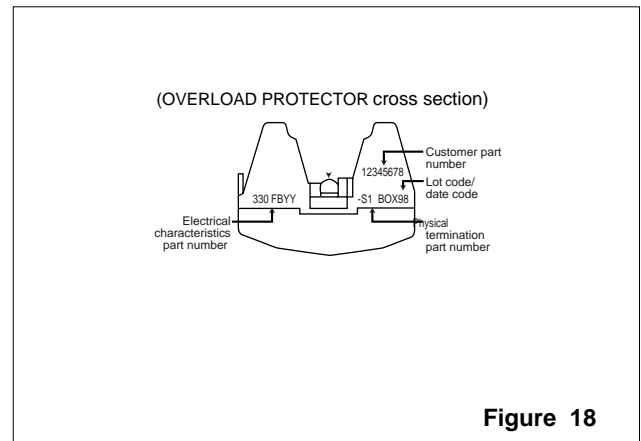

5. CIRCUIT DIAGRAM

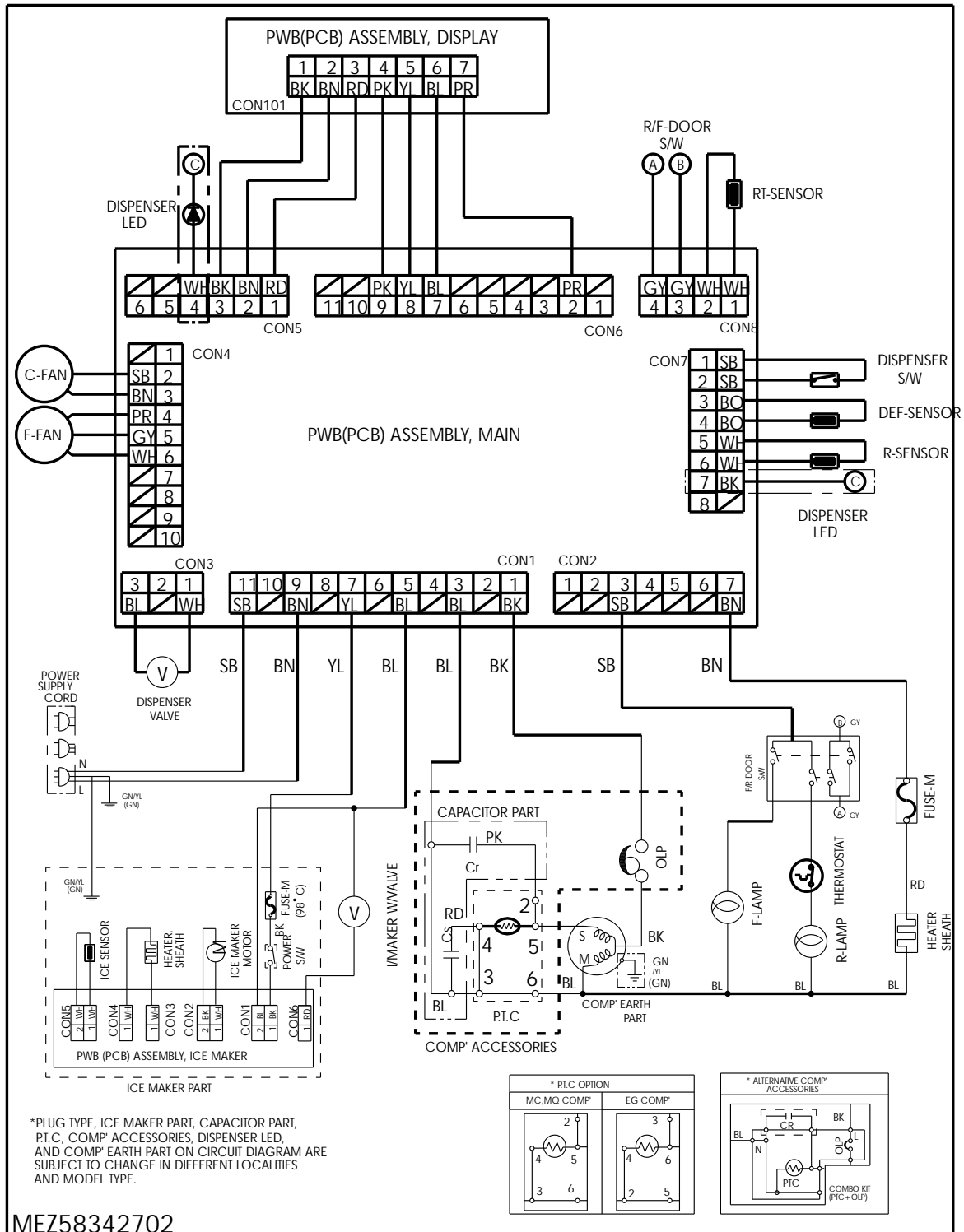

ME758342702

BK: BLACK	GN: GREEN	GY: GRAY	GN/YL: GREEN/YELLOW
YL: YELLOW	PK: PINK	WH: WHITE	BL/WH: BLUE/WHITE
SB: SKY BLUE	BO: BRIGHT ORANGE	BL: BLUE	BK/WH: BLACK/WHITE
BN: BROWN	PR: PURPLE	RD: RED	RD/WH: RED/WHITE

6. TROUBLESHOOTING

6-1 COMPRESSOR AND ELECTRIC COMPONENTS

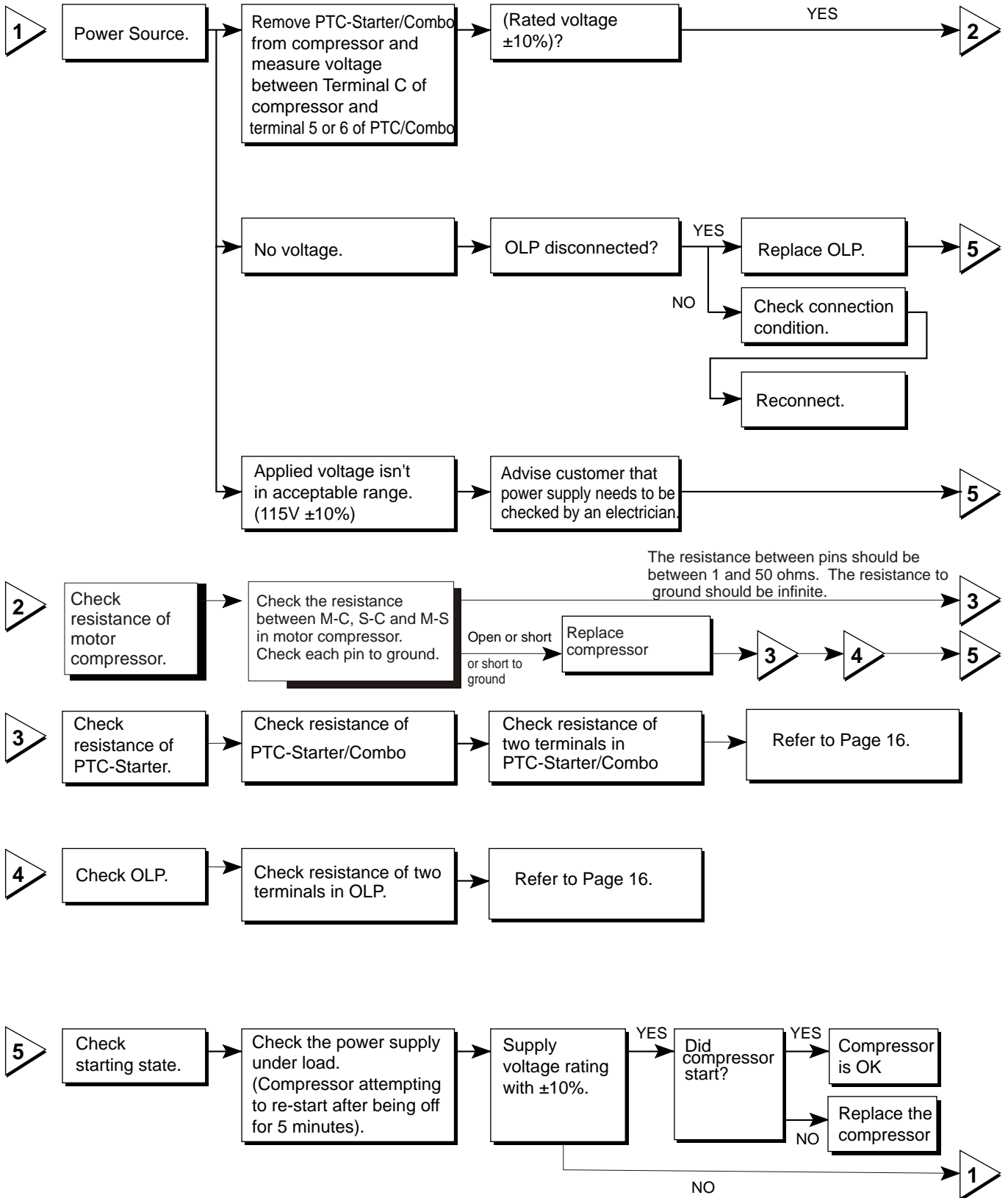

6-2 PTC / COMBO AND OLP

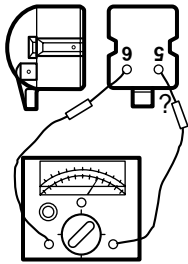
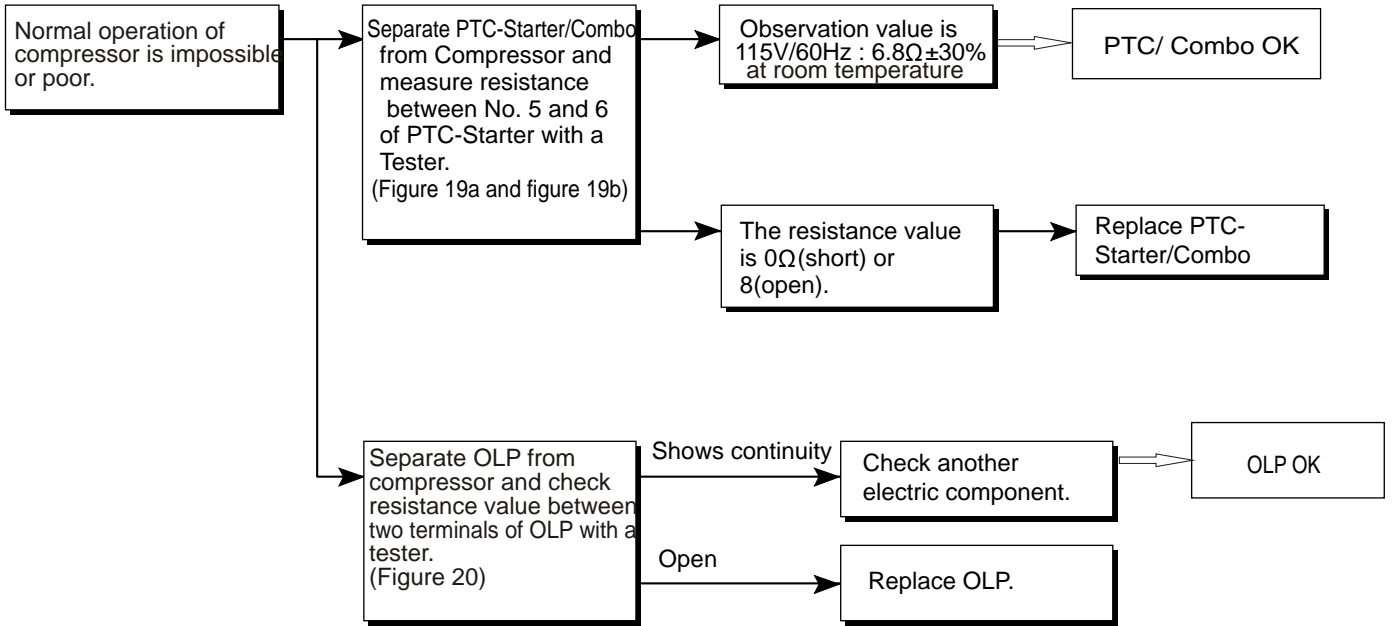

Figure 19a

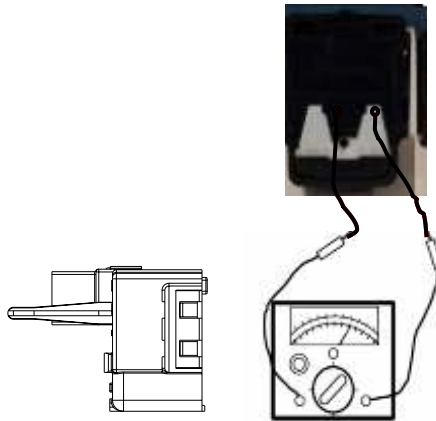

Figure 19b

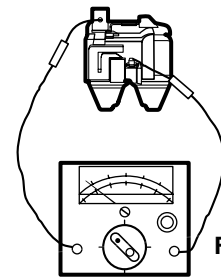
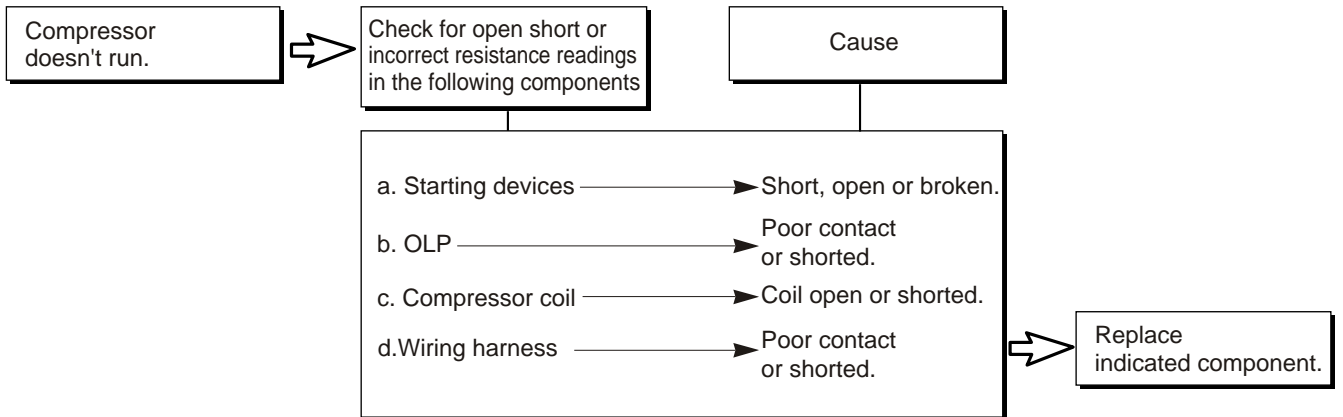

Figure 20

6-3 OTHER ELECTRIC COMPONENTS

• Not cooling at all



• Poor cooling performance

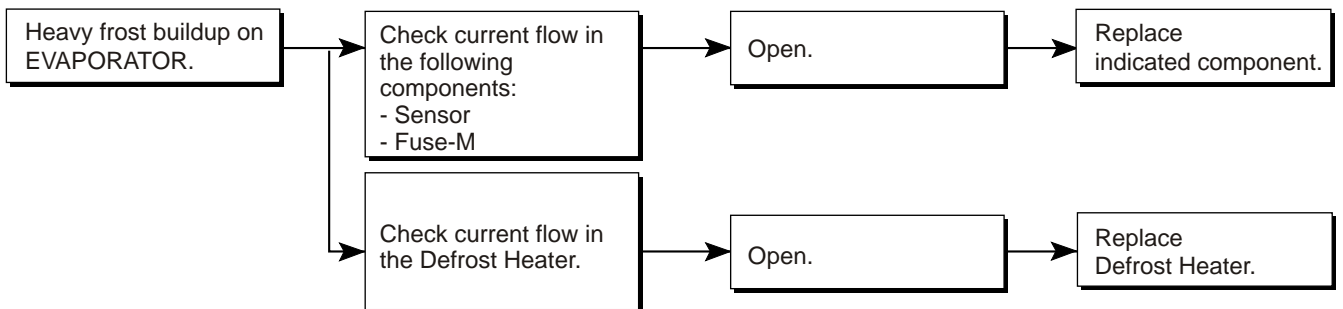
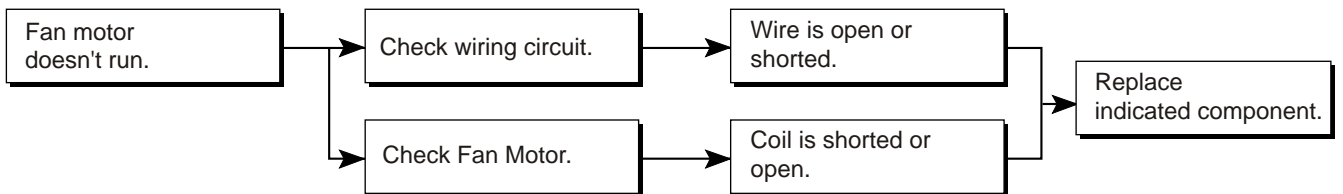
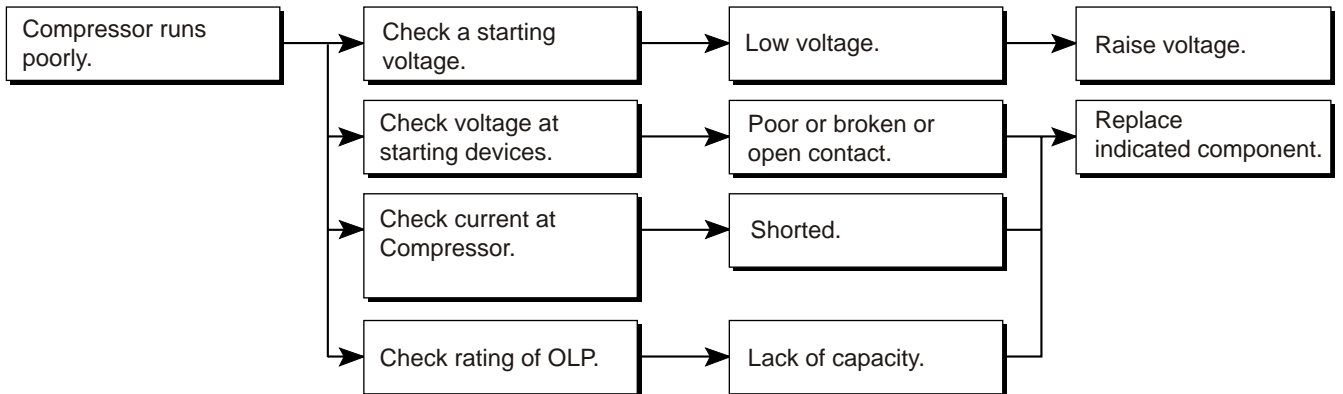

6-4 SERVICE DIAGNOSIS CHART

COMPLAINT	SYMPTOM	POSSIBLE CAUSES	SOLUTION
Electronic Display not operating correctly	1. No Display at all	<ol style="list-style-type: none"> 1. Supply voltage not within specifications 2. Open in wiring harness from PWB board 3. Open in door monitor switch circuit 	<ol style="list-style-type: none"> 1. Check supply voltage to refrigerator 2. Check wiring and connectors to PWB board 3. Check door monitor circuit
	2. Partial or abnormal display	<ol style="list-style-type: none"> 1. Supply voltage not within specifications 2. Open wiring harness from PWB board 	<ol style="list-style-type: none"> 1. Check supply voltage to refrigerator 2. Check wiring and connectors to PWB board
Not cooling	1. Display on but compressor not operating	<ol style="list-style-type: none"> 1. Compressor not operating 2. Open in compressor circuit 	<ol style="list-style-type: none"> 1. Check for compressor operation by using the test key on main circuit board. 2. Check for open on OLP, PTC, compressor, wiring, etc.
Not cold enough	1. Display on compressor is operating	<ol style="list-style-type: none"> 1. Condenser fan motor not operating 2. Condenser coils blocked 3. Evaporator fan motor not operating 4. Internal air flow blocked 5. Sensor not operating properly 6. Door not sealing 7. Evaporator frosted up 8. Sealed system related problem 	<ol style="list-style-type: none"> 1. Check condenser fan motor and wiring circuit 2. Check air flow across condenser 3. Check evaporator fan motor and wiring circuit 4. Check air ducts 5. Check refrigerator and freezer sensors 6. Check for proper door seal 7. Check defrost circuit components
Not defrosting	1. Freezer has too much frost	<ol style="list-style-type: none"> 1. Open in defrost circuit 2. Defrost sensor not operating correctly 3. Defrost drain clogged 	<ol style="list-style-type: none"> 1. Check defrost heater and circuit using Test Key 2. Check sensor 3. Check drain

6-5 REFRIGERATING CYCLE

• Troubleshooting Chart

CAUSE		STATE OF THE UNIT	STATE OF THE EVAPORATOR	TEMPERATURE OF THE COMPRESSOR	REMARKS
LEAKAGE	PARTIAL LEAKAGE	Freezer compartment and Refrigerator don't cool normally.	Low flowing sound of Refrigerant is heard and frost forms in inlet only.	A little higher than ambient temperature.	<ul style="list-style-type: none"> Refrigerant level is low due to a leak. Normal cooling is possible by restoring the normal amount of Refrigerant and repairing the leak.
	COMPLETE LEAKAGE	Freezer compartment and Refrigerator don't cool normally.	Flowing sound of refrigerant is not heard and frost isn't formed.	Equal to ambient temperature.	<ul style="list-style-type: none"> No discharging of Refrigerant. Normal cooling is possible by restoring the normal amount of refrigerant and repairing the leak.
RESTRICTED BY DUST	PARTIAL RESTRICTION	Freezer compartment and Refrigerator don't cool normally.	Flowing sound of refrigerant is heard and frost forms in inlet only.	A little higher than ambient temperature.	<ul style="list-style-type: none"> Normal discharging of the refrigerant. The capillary tube is faulty.
	WHOLE RESTRICTION	Freezer compartment and Refrigerator don't cool.	Flowing sound of refrigerant is not heard and frost isn't formed.	Equal to ambient temperature.	<ul style="list-style-type: none"> Normal discharging of the refrigerant.
MOISTURE RESTRICTION		Cooling operation stops periodically.	Flowing sound of refrigerant is not heard and frost melts.	Lower than ambient temperature.	<ul style="list-style-type: none"> Cooling operation restarts when heating the inlet of the capillary tube.
DEFECTIVE COMPRESSION	COMPRESSION	Freezer and Refrigerator don't cool.	Low flowing sound of refrigerant is heard and frost forms in inlet only.	A little higher ambient temperature.	<ul style="list-style-type: none"> Low pressure at high side of compressor due to low refrigerant level.
	NO COMPRESSION	No compressing operation.	Flowing sound of refrigerant is not heard and there is no frost.	Equal to ambient temperature.	<ul style="list-style-type: none"> No pressure in the high pressure part of the compressor.

Leakage Detection

Check sealed system for leak.

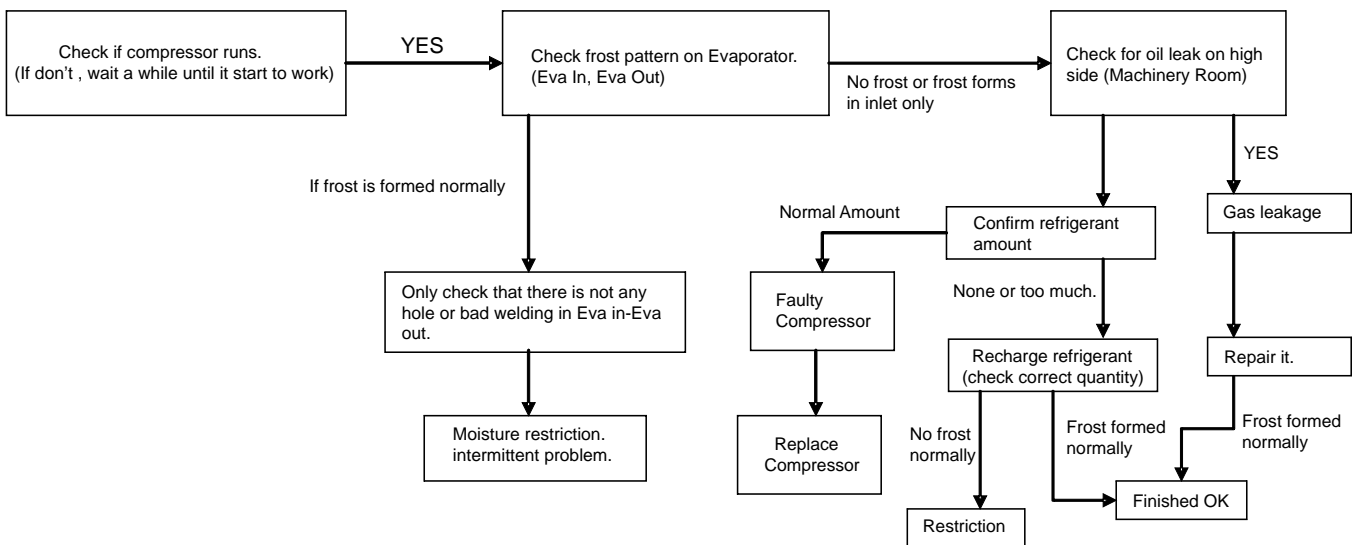

7. OPERATION PRINCIPLE AND REPAIR METHOD OF ICEMAKER

7-1 OPERATION PRINCIPLE

7-1-1 Operation Principle of Icemaker

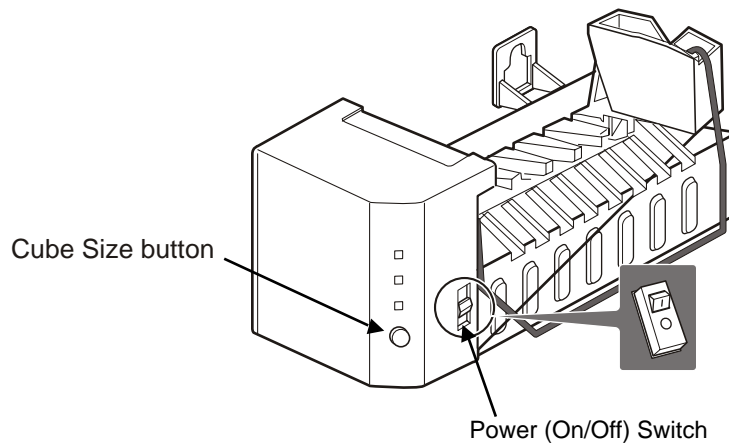
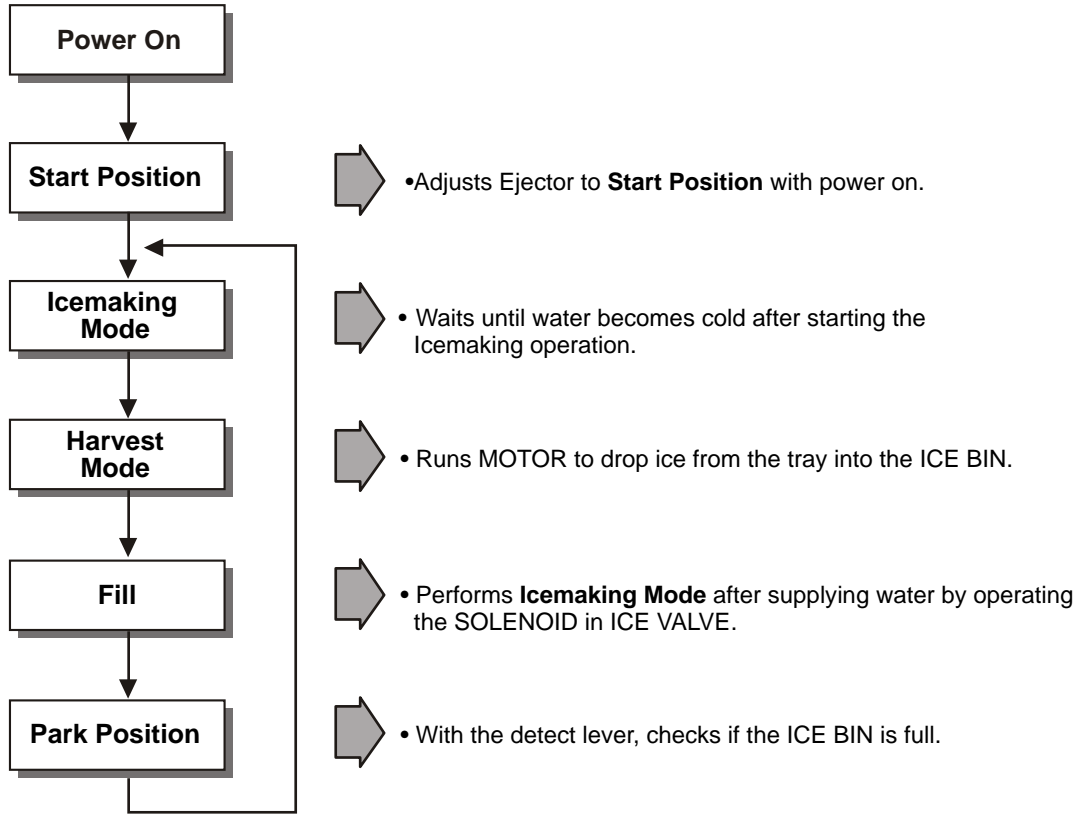

7-2 ICE MAKER FUNCTIONS

7-2-1 Ice Making Mode

1. Icemaking refers to the freezing of supplied water in the ice trays. Complete freezing is assured by measuring the temperature of the Tray with icemaking SENSOR.
2. Icemaking starts after completion of the water fill operation.
3. The icemaking function is completed when the sensor reaches -7°C , 60 to 240 minutes after starting.

NOTE : After icemaker power is ON, the icemaker heater will be on for test for 9 sec.

7-2-2 Harvest Mode

1. Harvest (Ice removing) refers to the operation of dropping ices into the ice bin from the tray when icemaking has completed.
2. Harvest mode:
 - (1) The Heater is ON for 30 seconds, then the motor starts.
 - (2) Harvest mode is completed if it reaches start position again while Heater & Motor are on at the same time.
 - A. ice bin is full : The EJECTOR stops (heater off).
 - B. ice bin is not full : The EJECTOR rotates twice to open for ice.

NOTE : If the EJECTOR does not rotate once within 5 minutes in status (2), separate heater control mode starts operating to prevent the EJECTOR from being constrained. (It is recommended that the user open for ice to return to normal mode.)

8. DESCRIPTION OF FUNCTION & CIRCUIT OF MICOM

8-1 FUNCTION

8-1-1 Function

1. When Appliance is plugged in for first time, is set "3" for the refrigerator. You can adjust the refrigerator control temperature by pressing the ADJUST button.
2. When the power is initially applied or restored a power failure, it is set at the last control temperature selected before the power initially applied or restored a power failure.

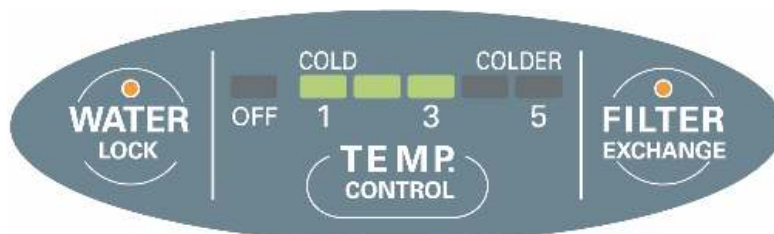

8-1-2 Defrost Cycle

Defrosting starts each time the accumulated COMPRESSOR running time is between 7 and 50 hours. This time is determinate by how long the doors are opened.

For initial power on or for restoring power, defrosting starts when the compressor running time reaches 4 hours.

Defrosting stops if the sensor temperature reaches 50 °F (10 °C) or more. If the sensor doesn't reach the 50 °F (10°C) in 1 hour, the defrost mode is malfunctioning. (Refer to the defect diagnosis function).

Defrosting won't function if the sensor is defective (wires are cut or short circuited)

8-1-3 Electrical Parts Operation in Sequence.

Electrical parts such as COMP, defrost heater, freezer FAN, etc. Operate in the following order to prevent noise and parts damage. Several parts are started at the same time at initial power on and are turned off together when TEST is completed.

	OPERATING	ORDER	REMARKS
INITIAL POWER ON	Temperature of defrost sensor is 113°F (45°C) or more .	<pre> graph LR A[POWER ON] -- "0.5 Sec" --> B[COMP, F-FAN ON] </pre>	
	Temperature of defrost sensor is lower than 113°F (45°C).	<pre> graph LR A[POWER ON] -- "0.5 Sec" --> B[Def-Heater ON] B -.-> C[Def-Heater OFF] C -- "10 Sec" --> D[COMP, F-FAN ON] D -- "0.5 Sec" --> E[] style E fill:none,stroke:none </pre>	

8-1-4 Defect Diagnosis Function

1. If there is a problem, an error code will appear..
2. The buttons will not operate.
3. When the problem is repaired, the display will return to normal.
4. The error code is displayed using the LEDs.

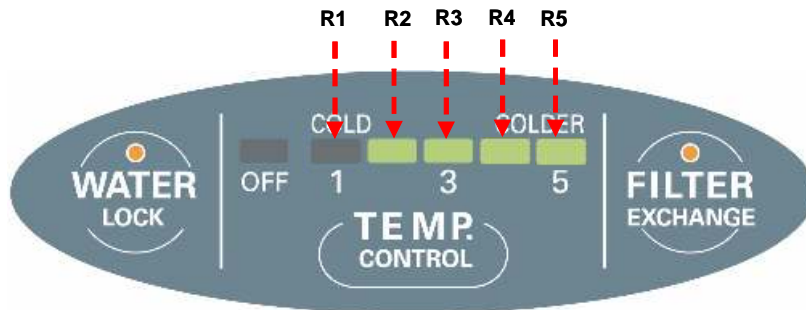

⊙ :ON ● :OFF

• ERROR CODE on Refrigerator Temperature panel

NO	Item	Error Code				Error Description	Remarks
		R2	R3	R4	R5		
1	Ref. Sensor	●	⊙	●	●	Ref. Sensor Open or Short	* Check each sensor
2	Heater Sensor	●	●	⊙	●	Defrost Sensor Open or Short	
3	RT Sensor	●	●	●	⊙	Ambient Sensor Open or Short	
4	Defrosting Problem	⊙	⊙	⊙	⊙	Defrost time last more than one hour and the defrost sensor never reach 10°C or 50°F	Check FUSE-M, DEF-SENSOR, Drain, Heater Drive Relay
5	F-FAN LOCK	●	⊙	⊙	⊙	F-FAN LOCKED	Check if something is locking the F-FAN

8-1-5 OFF Mode

For active this function you have to press the control button until the OFF mode led is ON. The OFF mode will take effect after 10 seconds.

When the OFF mode is active the compressor, the heater, water valve and the fans are inactive. Only the lamps (dispenser and R/F lamps) and the display are active in normal operation (Door open: R/F lamps and display ON).

For disable the function you have to press the control button until the desired Control LED is ON and the "OFF LED" will be inactive.

After 10 sec it will be a reset and the desired notch will be set.

If a Power Failure occur and the OFF MODE was active, it going to start in OFF MODE.



8-1-6 Lock Function

On initially operation the Lock Function is OFF.

If you wish lock the Water Dispenser, push on the WATER LOCK button, after this, the WATER LOCK LED on the Display will be turned ON..

When the Dispenser Lock Function is active the Dispenser lamp don't operate.

If you wish unlock the Water Dispenser, press the WATER LOCK button. Then the WATER LOCK LED on the Display will be turned OFF.



8-1-7 Filter Condition Display Function

There is a replacement indicator light for the water filter cartridge on the dispenser.

Water filter needs replacement once six months.

For reset the counter or turn OFF the filter change indicator press the lock button 3 sec and the counter will start from "0" and the filter change indicator will be OFF.

If the power OFF the data will be save in the memory (Power saving mode).



8-1-8 Dispenser Control (only for Dispenser models)

1. For active the water dispenser press and hold the dispenser switch.
2. For stop water dispenser release the dispenser switch.
3. When the door is open the Dispenser water valve can not be active.
4. If the Dispenser water valve is active and door OPEN the valve turn OFF.
5. When the OFF MODE is active the water valve is disable; only the Dispenser lamp operate normally.

8-1-9 Dispenser Lamp Function

1. Dispenser Lamp is ON while the water valve is active.

8-1-10 Dispenser water valve protection

If the water valve is active for 3 minutes continues, the water valve will turn OFF and can't be active.

If it is release and push again water can be dispensed.

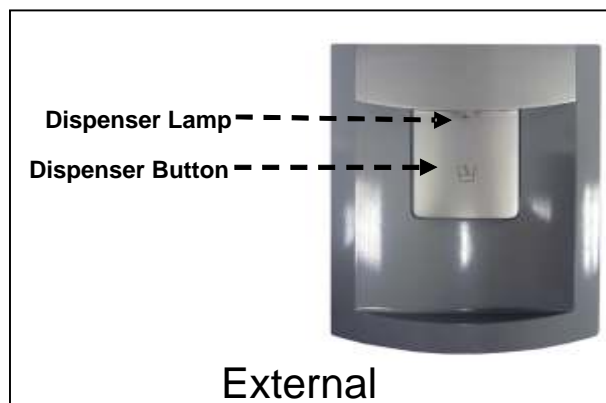

8-1-11 TEST MODE

1. Test mode allows checking the PCB and the function of the product as well as determining the Defective part in case of an error.
2. The test button is on the main PCB of the refrigerator (Test S/W).
- 3 While in the test mode, the ADJUST button will not operate.
4. After exiting the test mode, be sure to reset by unplugging and plugging in the appliance,
5. If an error, such as a sensor failure is detected while in the test mode, the test mode is cleared and the error code is displayed.
6. While an error code is displayed, the test mode will not be activated.

MODE	Key Control	Operation	Remarks									
TEST 1	Push the test button once	1) Continuous operation of the COMP, Freezer FAN and Cooling FAN. 2) DEFROSTING HEATER OFF 3) ALL DISPLAY ON 4) LAMP RELAY ON/OFF OPERATED BY DOOR SWITCH	*The maximum time for TEST 1 is 5 min.									
TEST	Push the test button once while in TEST MODE 1	1) COMP OFF 2) Freezer FAN and Cooling FAN OFF 3) Defrosting Heater ON 4) 1, 3, 5 LED ON	<div style="border: 1px solid black; padding: 5px; width: fit-content;"> <table style="width: 100%; text-align: center;"> <tr> <td>Ref.</td> <td>Temp.</td> <td>Display</td> </tr> <tr> <td>R1</td> <td>R3</td> <td>R5</td> </tr> <tr> <td>○</td> <td>●</td> <td>○</td> </tr> </table> <p>○ : ON ● : OFF</p> <p>Operate max 1 Hr</p> </div>	Ref.	Temp.	Display	R1	R3	R5	○	●	○
Ref.	Temp.	Display										
R1	R3	R5										
○	●	○										
RESET	Push the test button Once while in TEST MODE 2	Reset to the default settings (Compressor will delay 7 minutes for Power ON)										

8-2-1 Power Circuit

Power is supplied to the control board at the pin 11 and 9 of connector #1. (Refer to figure 1)

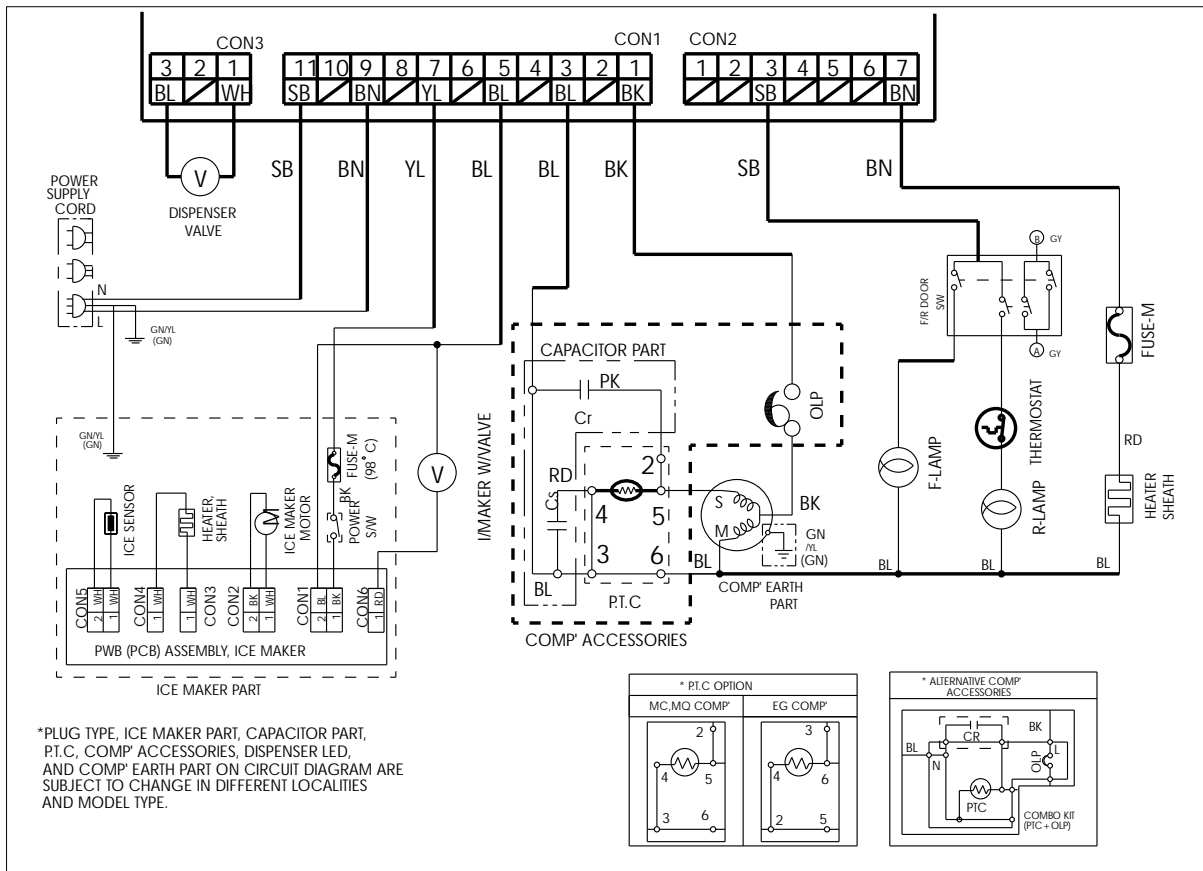

FIGURE 1

8-2-2 Load and Door Light Circuit (HV)

1. Load Drive Condition Check

To measure outputs of the control board, check voltages between the pins for the following components: (Refer to figure 1)

Circuit	Pin Number	Pin Number	Output Voltage
Compressor	Con 1 Pin 1	Con 1 Pin 3	115 VAC
Defrost Heater	Con 2 Pin 7	Con 1 Pin 3	115 VAC
R LAMP	Con 2 Pin 3	Con 1 Pin 3	115 VAC
Ice Maker	Con 1 Pin 7	Con 1 Pin 5	115 VAC
Dispenser Valve	Con 3 Pin 1	Con 3 Pin 3	115 VAC

CONNECTOR 1						
PIN	11	9	7	5	3	1
	N	L1	L(I/M)	N(I/M)	N	COMP

CONNECTOR 2				
PIN	1	3	5	7
	N/C	DOOR LAMP	N/C	DEF-HTR

CONNECTOR 3		
PIN	1	3
	DISP. VALVE	N

NOTE: When the door of the refrigerator is left open for 7 minutes or longer, the lamp of the refrigerator turns off automatically.

2. Door Monitor Circuit (LV)

Refrigerator	Measurement between pins 4 and 3 Con 8
Door Close	5 volts
Door Open	0 volts

CONNECTOR 8				
PIN	1	2	3	4
	RT-SNR		R-DOOR S/W	

8-2-3 Temperature Sensor Circuit (Refer to figure 2)

Voltage supplied to each sensor will range between 0.5 volts -22°F(-30°C) and 4.5 volts 122°F(50°C) depending upon the temperature in the compartments. A measurement of 0 volts indicates a short in the sensor circuit. A measurement of 5 volts indicates an open in the sensor circuit.

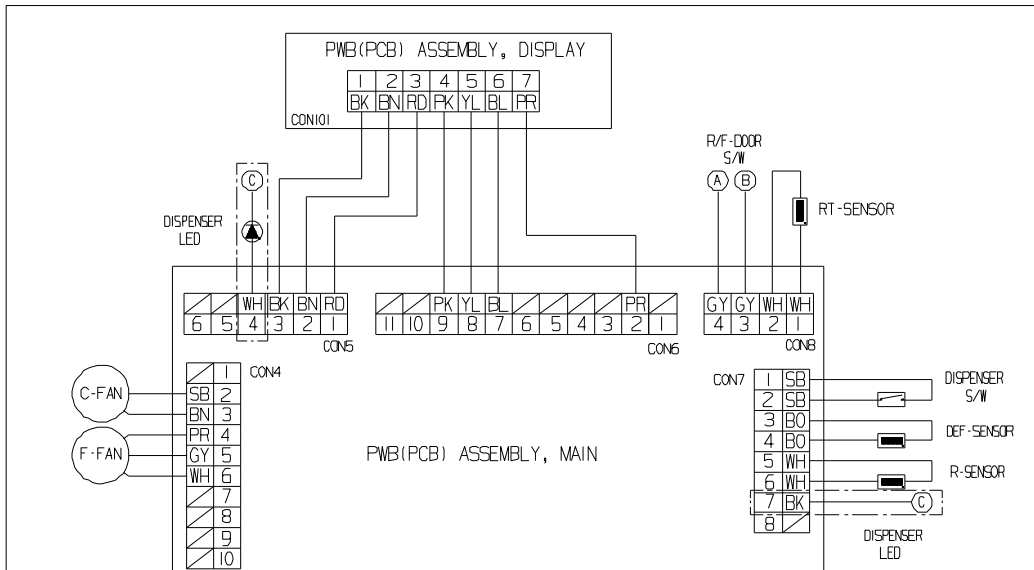

FIGURE 2

CONNECTOR 7								
PIN	1	2	3	4	5	6	7	8
	DISPENSER S/W		D-SNR		R-SNR		DISP LED GND	N/C

Refrigerator	Measurement between pins 1 and 2 Con 7
Disp.S/W ON	0 volts
Disp.S/W OFF	5 volts

CONNECTOR 5						
PIN	1	2	3	4	5	6
	DISPLAY			DISP LED	N/C	

Refrigerator	Measurement between Con 5 pin 4 and Con 7
Disp. LED ON	11 ~ 12 volts
Disp. LED OFF	0 volts

To measure the outputs of the sensors, check the voltages between the pins as in the table. And refer the values in the section **“RESISTANCE SPECIFICATION OF SENSOR”**

SENSOR	Pin Number	Pin Number
D-SNR	Con 7 Pin 3	Con 7 Pin 4
R-SNR	Con 7 Pin 5	Con 7 Pin 6
RT-SNR	Con 8 Pin 1	Con 8 Pin 2

To measure the outputs of the fans on the control boards check the voltages between the pins for the following components:

FAN	PIN NUMBER	PIN NUMBER	OUTPUT VOLTAGE	
			MOTOR ON	MOTOR OFF
Freezer Fan	Con 4 pin 5	Con 4 pin 6	10 - 14 VCD	2 VCD or less
Cooling Fan	Con 4 pin 2	Con 4 pin 3	10 - 14 VCD	2 VCD or less

CONNECTOR 4										
PIN	1	2	3	4	5	6	7	8	9	10
	C-FAN			F-FAN			N/C			
	N/C	G	V	F	G	V	N/C	N/C	N/C	N/C

8-3 RESISTANCE SPECIFICATION OF SENSOR

TEMPERATURE	RESISTANCE OF REFRIGERATOR & DEFROST SENSOR	VOLTAGE
-20 °C (-4 °F)	77 K	3.73
-15 °C (5 °F)	60 K	3.49
-10 °C (14 °F)	47.3 K	3.22
-5 °C (23 °F)	38.4 K	2.95
0 °C (32 °F)	30 K	2.67
5 °C (41 °F)	24.1 K	2.4
10 °C (50 °F)	19.5 K	2.14
15 °C (59 °F)	15.9 K	1.89
20 °C (68 °F)	13 K	1.66
25 °C (77 °F)	11 K	1.46
30 °C (86 °F)	8.9 K	1.27
40 °C (104 °F)	6.2 K	0.96
50 °C (122 °F)	4.3 K	0.72

- The resistance of the SENSOR has a $\pm 5\%$ common difference.
- Temperature of the SENSOR must be stabilized for minimum of 3 minutes before accurate measurement can be taken.

EXPLODED VIEW (External Models)

CASE PARTS

CAUTION: Use the part number to order part, not the position number

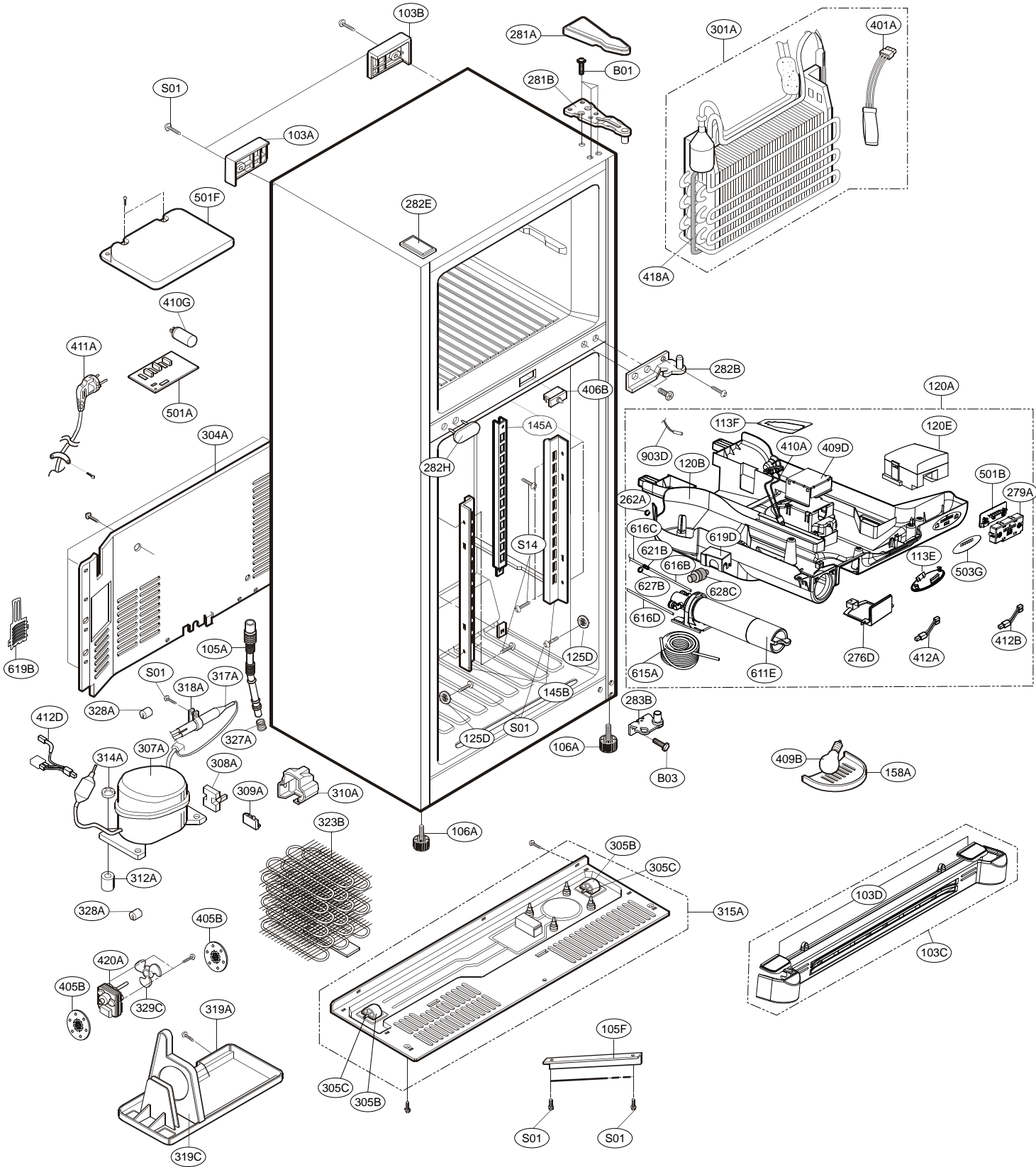

FREEZER PARTS

CAUTION: Use the part number to order part, not the position number

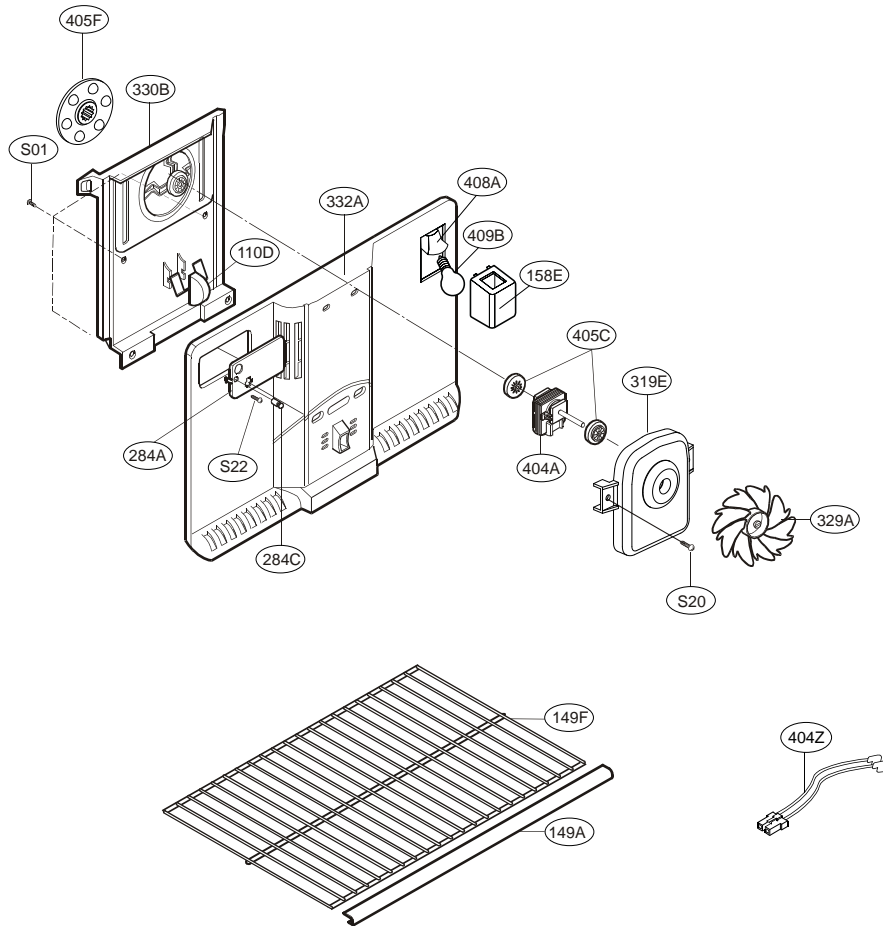

REFRIGERATOR PARTS

CAUTION: Use the part number to order part, not the position number

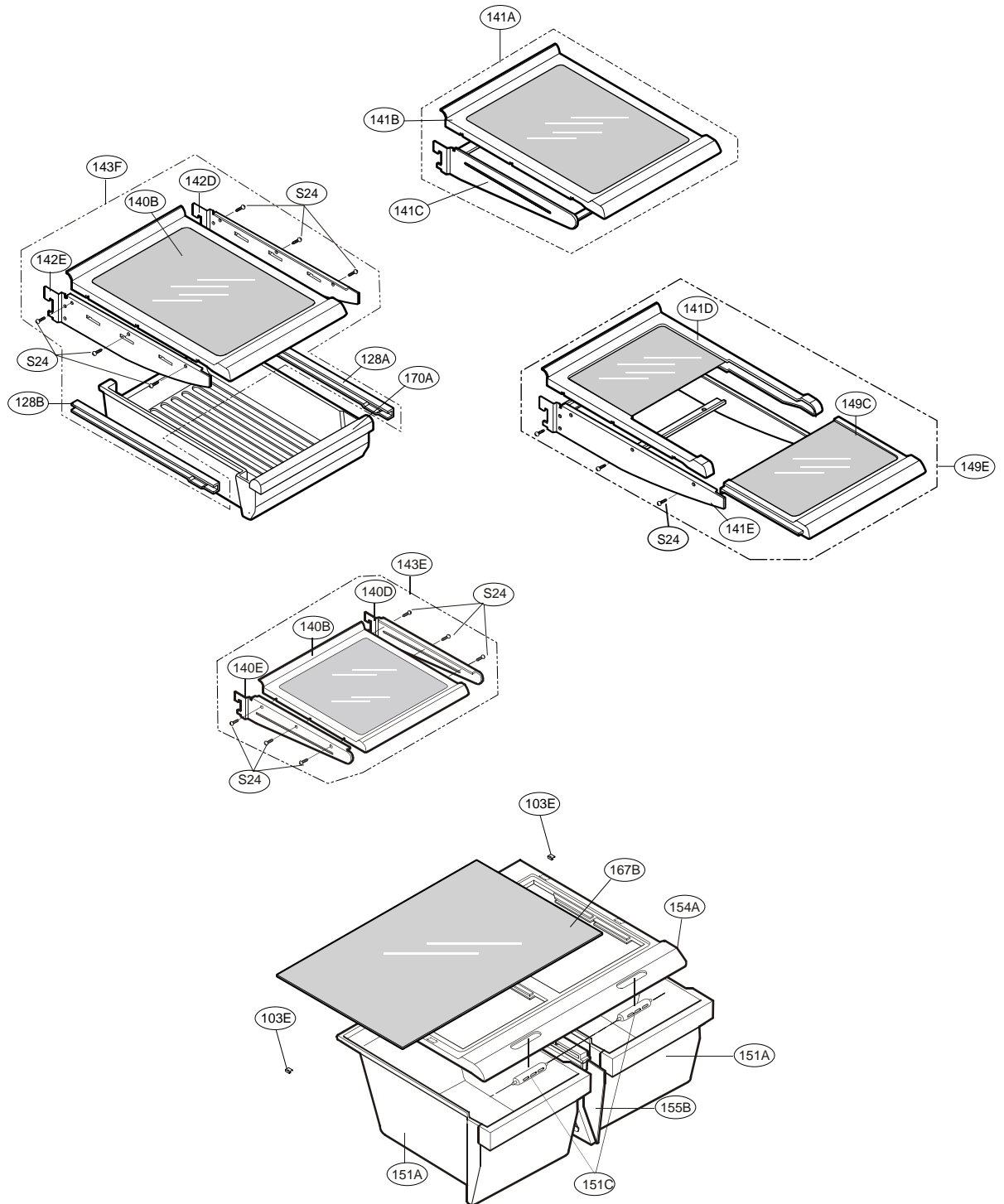

DOOR PARTS

CAUTION: Use the part number to order part, not the position number

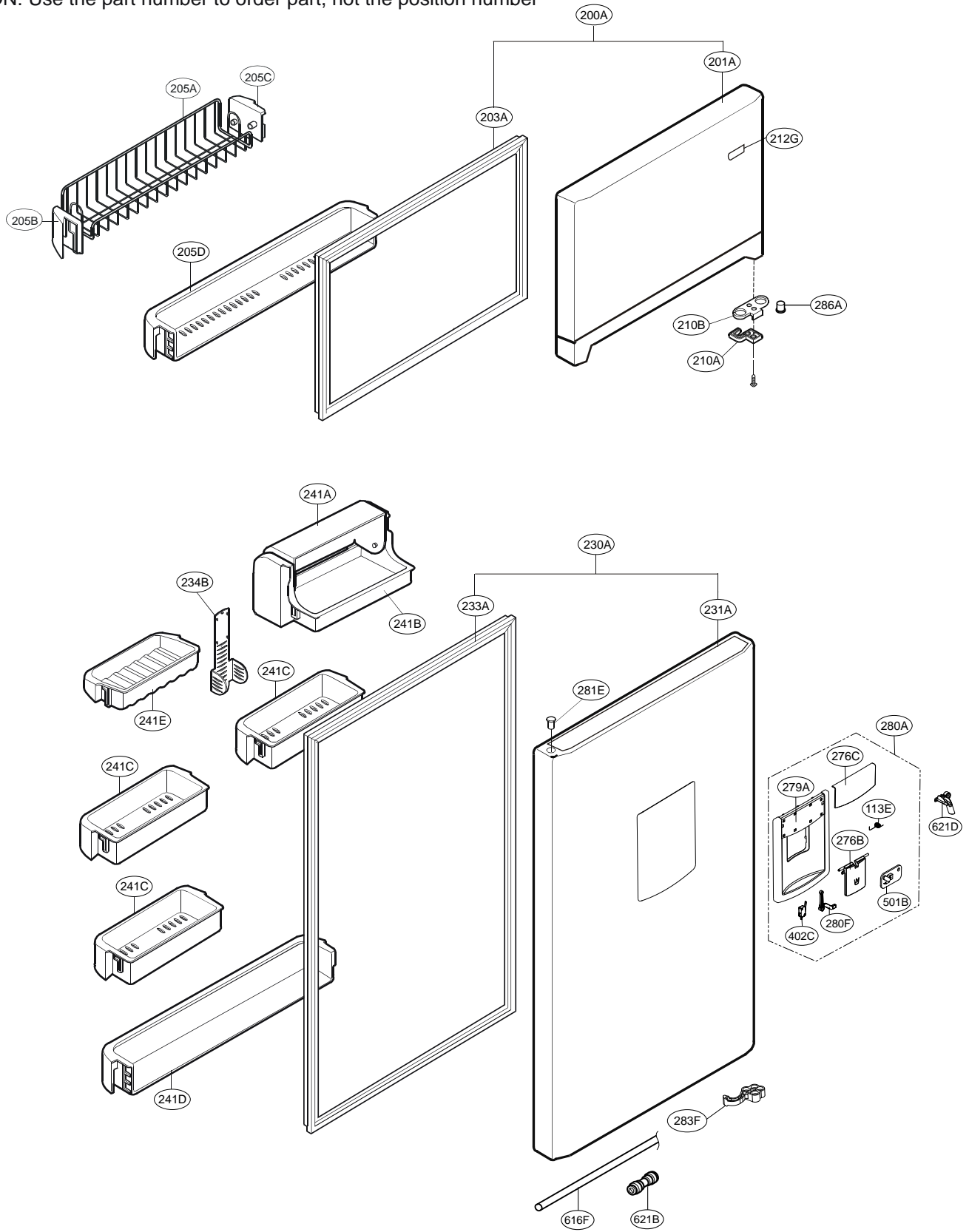

ICE MAKER PARTS

CAUTION: Use the part number to order part, not the position number

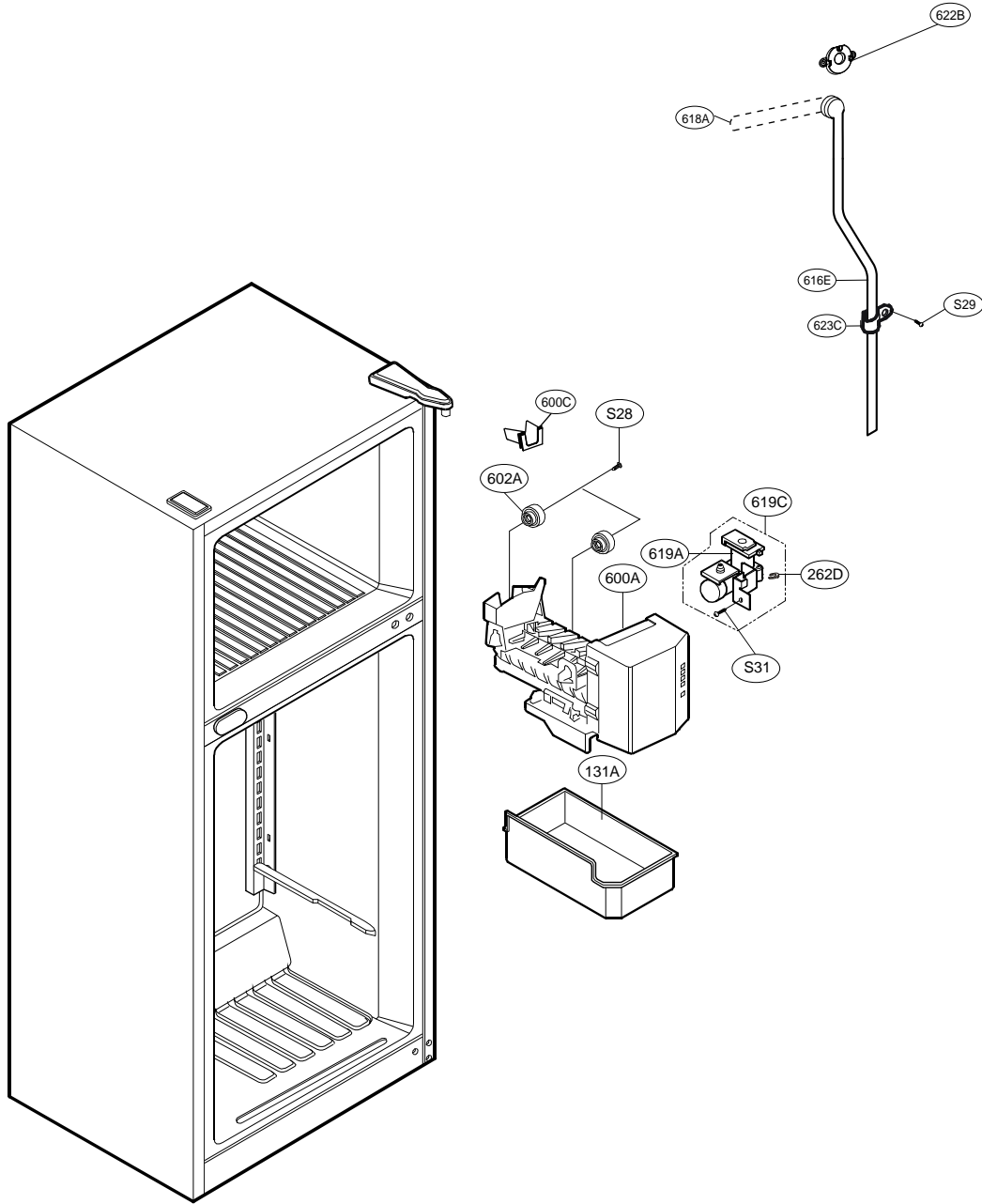

Loc No.	Part No.	Description	Loc No.	Part No.	Description
103A	3650JJ2003E	Handle,Rear	305B	4580JJ3001A	Roller
103B	3650JJ2003A	Handle,Rear	305C	4J04238A	Pin,Common
103C	ACQ74567801	Cover Assembly,Lower	307A	TCA33414101	Compressor,Set Assembly
103D	MCK62049501	Cover,Lower	308A	6748C-0004D	Thermistor Assembly,PTC
103E	5218JJ3001A	Rail,Slide	309A	6750C-0005P	Overload Protect
105A	5251JA3003B	Tube Assembly,Drain	310A	3550JA2042C	Cover,PTC
105F	5070JJ3002A	Skirt,Lower	312A	5040JA3031A	Damper,Compressor
106A	4779JA2003A	Leg Assembly,Adjust	314A	4620JA3009B	Stopper,Compressor
110D	4940JL2001C	Knob,Shutter	315A	3103JJ1001N	Base Assembly,Compressor
113E	MCR60014901	Decor,Control	317A	5851JJ2002F	Drier Assembly
113F	MJH61849501	Supporter	318A	4930JA3034A	Holder,Drier
120A	ABQ72930501	Case Assembly,Control Refrigerator	319A	3390JJ0004A	Tray,Drip
120B	MBN60108701	Case,Control Refrigerator	319C	MEA41997401	Guide,Fan
120E	5209JJ1001C	Duct Assembly,Insulation	319E	4810JJ2005A	Bracket,Motor
125D	4930JJ3007A	Holder,Bracket	323B	5403JJ1008A	Condenser Assembly,Wire
128A	4975JJ2002A	Guide Assembly,Rail	327A	5006JA3034A	Cap,Drain Tube
128B	4975JJ2002B	Guide Assembly,Rail	328A	4J03020A	Damper,Pipe
131A	5074JJ1007A	Bucket,Ice	328A	4J03020A	Damper,Pipe
140B	5027JJ1039A	Shelf Assembly,Refrigerator	329A	5901JJ1003A	Fan Assembly
141A	5027JJ1014F	Shelf Assembly,Refrigerator	329C	ADP36665702	Fan Assembly
141B	5027JJ1038A	Shelf Assembly,Refrigerator	330B	MHN58555001	Shroud,Freezer
141C	5027JJ2005U	Shelf Assembly,Net	332A	3531JJ1005H	Grille Assembly,Fan
141D	5027JJ2011B	Shelf Assembly,Refrigerator	401A	4781JK2001A	Controller Assembly
141E	5027JJ2005V	Shelf Assembly,Net	402C	6600JB3001C	Switch,Micro
142D	5026JJ2001L	Shelf,Net	404A	4681JK1004A	AC Motor
142E	5026JJ2001M	Shelf,Net	404Z	6877JB1223F	Harness Assembly
143F	5027JJ1013S	Shelf Assembly,Refrigerator	405B	5040JJ2001A	Damper,Motor Support
145A	4930JJ2003A	Holder,Shelf	405C	5040JA2009B	Damper,Motor Support
145B	4930JJ2004A	Holder,Shelf	405F	5040JA2004B	Damper,Motor Support
149A	3806JJ3001B	Decor,Shelf	406B	6600JB2004A	Switch,Push Button
149C	5027JJ2010B	Shelf Assembly,Refrigerator	408A	6621JK2001A	Harness Assembly
149E	5027JJ2009D	Shelf Assembly,Refrigerator	409B	6912JK2002E	Lamp,Incandescent
149F	MHL58275201	Shelf,Freezer	409D	MGW61842601	Reflector,Lamp
151A	3391JJ1020B	Tray Assembly,Vegetable	410A	EAD60664701	Harness Assembly
151C	4940JJ2003C	KNOB,SHUTTER	410G	0CZZJB2012J	Capacitor,Electric Appliance Film,Box
154A	MCK61620302	Cover,TV	411A	6411JK1006A	Power Cord Assembly
155B	4980JJ1010A	Supporter,Cover TV	412A	EAD59672202	Harness Assembly
158A	3550JJ2027A	Cover,Lamp	412B	EAD59741301	Harness Assembly
158E	3550JJ2017C	Cover,Lamp	412D	6877JK2011D	Harness Assembly
167B	4890JL1002V	Shelf,Glass	418A	5300JK1003J	Heater,Sheath
170A	3391JJ2004H	Tray Assembly,Meat	420A	4681JB1029J	Motor,DC
200A	ADC71006706	Door Assembly,Freezer	501A	EBR41531308	PCB Assembly,Main
201A	ADD71006806	Door Foam Assembly,Freezer	501B	EBR59400501	PCB Assembly,Display
203A	4987JJ1004T	Gasket Assembly,Door	501C	6871JB2074F	PCB Assembly,Display
205A	5004JJ1017B	Basket,Door	501F	3551JJ1020A	Cover Assembly,PCB
205B	5004JJ2002A	Basket,Tilt	503G	MCR61620401	Decor,Control
205C	5004JJ2003A	Basket,Tilt	600A	5989JA0002P	Ice Maker Assembly,Kit
205D	5004JJ1024A	Basket,Door	600C	MEA32865501	Guide,Tube
210A	4620JJ2009A	Stopper,Door	602A	4931JA3005B	Holder Assembly,Bracket
210B	4974JA3031B	Guide,Stopper	611E	5231JA2005E	Filter Assembly,Head
212G	4140JD1031A	Name Plate	615A	MJM61842001	Tank,Water
230A	ADC71006921	Door Assembly,Refrigerator	616B	5210JA3030W	Tube,Plastic
231A	ADD72914401	Door Foam Assembly,Refrigerator	616C	5210JA3030Y	Tube,Plastic
233A	4987JJ1004U	Gasket Assembly,Door	616D	AJR72929601	Tube Assembly,Inject
241A	3550JL2003M	Cover,Tray	616E	5211JA2003C	Tube Assembly,Inject
241B	5004JJ1036A	Basket,Door	616F	MJU61929202	Tube,Plastic
241C	AAP72909002	Basket Assembly,Door	618A	5210JJ3006B	Tube,Inject
241D	5004JJ1025A	Basket,Door	619A	5220JA2009B	Valve,Water
241E	5004JJ1038A	Basket,Door	619B	3550JJ2024A	Cover,Valve
262A	4930JA3093A	Holder,Bracket	619C	AJU55759302	Valve Assembly,Water
262D	4004JA3002A	Clip	619D	MCK61866101	Cover,Valve
276B	MBG60108801	Button,Lever	621B	4932JA3002F	Connector,Tube
276C	MCR60014801	Decor,Dispenser	621C	MCD38280803	Connector,Tube
276D	MCK62049601	Cover,Front	621D	MJU60108901	Tube,Inject
279A	MBN60007701	Case,Display	622B	MJH61841901	Supporter,Tube Guide
279B	MCK60008101	Cover,Dispenser	623C	4770JA3001A	Band
280A	ACQ74487301	Cover Assembly,Dispenser	627B	4930JA3091A	Holder,Bracket
280F	MFC60678401	Lever,Dispenser	628C	5220JB2001A	Valve,Water
281A	3550JJ2013A	Cover,Hinge	630K	4970JA3022B	Spring,Plate
281B	4775JJ2003B	Hinge Assembly,Upper	903D	6500JK1003A	Sensor, Temperature
281E	5006JJ3003A	Cap,Hinge	B01	J351-00004L	Screw,Customized
282B	4775JJ2002A	Hinge Assembly,Center	B03	J351-00004P	Screw,Customized
282E	5006JJ2001A	Cap,Hinge	S01	4J00415D	Screw,Customized
282H	5006JJ3004A	Cap,Hinge	S14	3J05696W	Screw,Customized
283B	AEH72914701	Hinge Assembly,Lower	S20	4001JA3001A	Screw Assembly
283F	4620JJ2007A	Stopper,Door	S22	J471-00001J	Screw,Customized
284A	3550JJ2023A	Cover,Grille Fan	S24	1SZZJA3011B	Screw,Customized
284C	5006JA3080A	Cap,Screw	S28	1SZZJJ3005E	Screw,Customized
286A	4984JJ3003A	BUSH	S29	4J00415D	Screw,Customized
301A	5421J0002A	Evaporator Assembly	S31	4000W4A003A	Screw,Customized
304A	3551JJ2008B	Cover Assembly,Machinery(Rear)	S38	4J00415D	Screw,Customized

Loc No.	Part No.	Description	Loc No.	Part No.	Description
103A	3650JJ2003H	Handle,Rear	305B	4580JJ3001A	Roller
103B	3650JJ2003D	Handle,Rear	305C	4J04238A	Pin,Common
103C	ACQ74567803	Cover Assembly,Lower	307A	TCA33414101	Compressor,Set Assembly
103D	MCK62049503	Cover,Lower	308A	6748C-0004D	Thermistor Assembly,PTC
103E	5218JJ3001A	Rail,Slide	309A	6750C-0005P	Overload Protect
105A	5251JA3003B	Tube Assembly,Drain	310A	3550JA2042C	Cover,PTC
105F	5070JJ3002A	Skirt,Lower	312A	5040JA3031A	Damper,Compressor
106A	4779JA2003A	Leg Assembly,Adjust	314A	4620JA3009B	Stopper,Compressor
110D	4940JL2001C	Knob,Shutter	315A	3103JJ1001N	Base Assembly,Compressor
113E	MCR60014901	Decor,Control	317A	5851JJ2002F	Drier Assembly
113F	MJH61849501	Supporter	318A	4930JA3034A	Holder,Drier
120A	ABQ72930501	Case Assembly,Control Refrigerator	319A	3390JJ0004A	Tray,Drip
120B	MBN60108701	Case,Control Refrigerator	319C	MEA41997401	Guide,Fan
120E	5209JJ1001C	Duct Assembly,Insulation	319E	4810JJ2005A	Bracket,Motor
125D	4930JJ3007A	Holder,Bracket	323B	5403JJ1008A	Condenser Assembly,Wire
128A	4975JJ2002A	Guide Assembly,Rail	327A	5006JA3034A	Cap,Drain Tube
128B	4975JJ2002B	Guide Assembly,Rail	328A	4J03020A	Damper,Pipe
131A	5074JJ1007A	Bucket,Ice	328A	4J03020A	Damper,Pipe
140B	5027JJ1039A	Shelf Assembly,Refrigerator	329A	5901JJ1003A	Fan Assembly
141A	5027JJ1014F	Shelf Assembly,Refrigerator	329C	ADP36665702	Fan Assembly
141B	5027JJ1038A	Shelf Assembly,Refrigerator	330B	MHN58555001	Shroud,Freezer
141C	5027JJ2005U	Shelf Assembly,Net	332A	3531JJ1005H	Grille Assembly,Fan
141D	5027JJ2011B	Shelf Assembly,Refrigerator	401A	4781JK2001A	Controller Assembly
141E	5027JJ2005V	Shelf Assembly,Net	402C	6600JB3001C	Switch,Micro
142D	5026JJ2001L	Shelf,Net	404A	4681JK1004A	AC Motor
142E	5026JJ2001M	Shelf,Net	404Z	6877JB1223F	Harness Assembly
143F	5027JJ1013S	Shelf Assembly,Refrigerator	405B	5040JJ2001A	Damper,Motor Support
145A	4930JJ2003A	Holder,Shelf	405C	5040JA2009B	Damper,Motor Support
145B	4930JJ2004A	Holder,Shelf	405F	5040JA2004B	Damper,Motor Support
149A	3806JJ3001B	Decor,Shelf	406B	6600JB2004C	Switch,Push Button
149C	5027JJ2010B	Shelf Assembly,Refrigerator	408A	6621JK2001A	Harness Assembly
149E	5027JJ2009D	Shelf Assembly,Refrigerator	409B	6912JK2002E	Lamp,Incandescent
149F	MHL58275201	Shelf,Freezer	409D	MGW61842601	Reflector,Lamp
151A	3391JJ1020B	Tray Assembly,Vegetable	410A	EAD60664701	Harness Assembly
151C	4940JJ2003C	KNOB,SHUTTER	410G	0CZZJB2012J	Capacitor,Electric Appliance Film,Box
154A	MCK61620302	Cover,TV	411A	6411JK1006A	Power Cord Assembly
155B	4980JJ1010A	Supporter,Cover TV	412A	EAD59672202	Harness Assembly
158A	3550JJ2027A	Cover,Lamp	412B	EAD59741301	Harness Assembly
158E	3550JJ2017C	Cover,Lamp	412D	6877JK2011D	Harness Assembly
167B	4890JL1002V	Shelf,Glass	418A	5300JK1003J	Heater,Sheath
170A	3391JJ2004H	Tray Assembly,Meat	420A	4681JB1029J	Motor,DC
200A	ADC71006710	Door Assembly,Freezer	501A	EBR41531308	PCB Assembly,Main
201A	ADD71006809	Door Foam Assembly,Freezer	501B	EBR59400501	PCB Assembly,Display
203A	ADX52752625	Gasket Assembly,Door	501C	6871JB2074F	PCB Assembly,Display
205A	5004JJ1017B	Basket,Door	501F	3551JJ1020A	Cover Assembly,PCB
205B	5004JJ2002A	Basket,Tilt	503G	MCR61620401	Decor,Control
205C	5004JJ2003A	Basket,Tilt	600A	5989JA0002P	Ice Maker Assembly,Kit
205D	5004JJ1024A	Basket,Door	600C	MEA32865501	Guide,Tube
210A	4620JJ2009A	Stopper,Door	602A	4931JA3005B	Holder Assembly,Bracket
210B	4974JA3031B	Guide,Stopper	611E	5231JA2005E	Filter Assembly,Head
212G	4140JD1031A	Name Plate	615A	MJM61842001	Tank,Water
230A	ADC71006923	Door Assembly,Refrigerator	616B	5210JA3030W	Tube,Plastic
231A	ADD72914403	Door Foam Assembly,Refrigerator	616C	5210JA3030Y	Tube,Plastic
233A	ADX52752624	Gasket Assembly,Door	616D	AJR72929601	Tube Assembly,Inject
241A	3550JL2003M	Cover,Tray	616E	5211JA2003C	Tube Assembly,Inject
241B	5004JJ1036A	Basket,Door	616F	MJU61929202	Tube,Plastic
241C	AAP72909002	Basket Assembly,Door	618A	5210JJ3006B	Tube,Inject
241D	5004JJ1025A	Basket,Door	619A	5220JA2009B	Valve,Water
241E	5004JJ1038A	Basket,Door	619B	3550JJ2024A	Cover,Valve
262A	4930JA3093A	Holder,Bracket	619C	AJU55759302	Valve Assembly,Water
262D	4004JA3002A	Clip	619D	MCK61866101	Cover,Valve
276B	MBG60108802	Button,Lever	621B	4932JA3002F	Connector,Tube
276C	MCR60014802	Decor,Dispenser	621C	MCD38280803	Connector,Tube
276D	MCK62049601	Cover,Front	621D	MJU60108904	Tube,Inject
279A	MBN60007701	Case,Display	622B	MJH61841901	Supporter,Tube Guide
279B	MCK60008104	Cover,Dispenser	623C	4770JA3001A	Band
280A	ACQ74487303	Cover Assembly,Dispenser	627B	4930JA3091A	Holder,Bracket
280F	MFC60678401	Lever,Dispenser	628C	5220JB2001A	Valve,Water
281A	3550JJ2013D	Cover,Hinge	630K	4970JA3022B	Spring,Plate
281B	4775JJ2003B	Hinge Assembly,Upper	903D	6500JK1003A	Sensor,Temperature
281E	5006JJ3003F	Cap,Hinge	B01	J351-00004L	Screw,Customized
282B	4775JJ2002A	Hinge Assembly,Center	B03	J351-00004P	Screw,Customized
282E	5006JJ2001G	Cap,Hinge	S01	4J00415D	Screw,Customized
282H	5006JJ3004F	Cap,Hinge	S14	3J05696W	Screw,Customized
283B	AEH72914701	Hinge Assembly,Lower	S20	4001JA3001A	Screw Assembly
283F	4620JJ2007A	Stopper,Door	S22	J471-00001J	Screw,Customized
284A	3550JJ2023A	Cover,Grille Fan	S24	1SZZJA3011B	Screw,Customized
284C	5006JA3080A	Cap,Screw	S28	1SZZJJ3005E	Screw,Customized
286A	4984JJ3003A	BUSH	S29	4J00415D	Screw,Customized
301A	5421JJ0002A	Evaporator Assembly	S31	4000W4A003A	Screw,Customized
304A	3551JJ2008B	Cover Assembly,Machinery(Rear)	S38	4J00415D	Screw,Customized

Loc No.	Part No.	Description	Loc No.	Part No.	Description
103A	3650JJ2003M	Handle,Rear	305B	4580JJ3001A	Roller
103B	3650JJ2003L	Handle,Rear	305C	4J04238A	Pin,Common
103C	ACQ74567802	Cover Assembly,Lower	307A	TCA33414101	Compressor,Set Assembly
103D	MCK62049502	Cover,Lower	308A	6748C-0004D	Thermistor Assembly,PTC
103E	5218JJ3001A	Rail,Slide	309A	6750C-0005P	Overload Protect
105A	5251JA3003B	Tube Assembly,Drain	310A	3550JA2042C	Cover,PTC
105F	5070JJ3002A	Skirt,Lower	312A	5040JA3031A	Damper,Compressor
106A	4779JA2003A	Leg Assembly,Adjust	314A	4620JA3009B	Stopper,Compressor
110D	4940JL2001C	Knob,Shutter	315A	3103JJ1001N	Base Assembly,Compressor
113E	MCR60014901	Decor,Control	317A	5851JJ2002F	Drier Assembly
113F	MJH61849501	Supporter	318A	4930JA3034A	Holder,Drier
120A	ABQ72930501	Case Assembly,Control Refrigerator	319A	3390JJ0004A	Tray,Drip
120B	MBN60108701	Case,Control Refrigerator	319C	MEA41997401	Guide,Fan
120E	5209JJ1001C	Duct Assembly,Insulation	319E	4810JJ2005A	Bracket,Motor
125D	4930JJ3007A	Holder,Bracket	323B	5403JJ1008A	Condenser Assembly,Wire
128A	4975JJ2002A	Guide Assembly,Rail	327A	5006JA3034A	Cap,Drain Tube
128B	4975JJ2002B	Guide Assembly,Rail	328A	4J03020A	Damper,Pipe
131A	5074JJ1007A	Bucket,Ice	328A	4J03020A	Damper,Pipe
140B	5027JJ1039A	Shelf Assembly,Refrigerator	329A	5901JJ1003A	Fan Assembly
141A	5027JJ1014F	Shelf Assembly,Refrigerator	329C	ADP36665702	Fan Assembly
141B	5027JJ1038A	Shelf Assembly,Refrigerator	330B	MHN58555001	Shroud,Freezer
141C	5027JJ2005U	Shelf Assembly,Net	332A	3531JJ1005H	Grille Assembly,Fan
141D	5027JJ2011B	Shelf Assembly,Refrigerator	401A	4781JK2001A	Controller Assembly
141E	5027JJ2005V	Shelf Assembly,Net	402C	6600JB3001C	Switch,Micro
142D	5026JJ2001L	Shelf,Net	404A	4681JK1004A	AC Motor
142E	5026JJ2001M	Shelf,Net	404Z	6877JB1223F	Harness Assembly
143F	5027JJ1013S	Shelf Assembly,Refrigerator	405B	5040JJ2001A	Damper,Motor Support
145A	4930JJ2003A	Holder,Shelf	405C	5040JA2009B	Damper,Motor Support
145B	4930JJ2004A	Holder,Shelf	405F	5040JA2004B	Damper,Motor Support
149A	3806JJ3001B	Decor,Shelf	406B	6600JB2004B	Switch,Push Button
149C	5027JJ2010B	Shelf Assembly,Refrigerator	408A	6621JK2001A	Harness Assembly
149E	5027JJ2009D	Shelf Assembly,Refrigerator	409B	6912JK2002E	Lamp,Incandescent
149F	MHL58275201	Shelf,Freezer	409D	MGW61842601	Reflector,Lamp
151A	3391JJ1020B	Tray Assembly,Vegetable	410A	EAD60664701	Harness Assembly
151C	4940JJ2003C	KNOB,SHUTTER	410G	0CZZJB2012J	Capacitor,Electric Appliance Film,Box
154A	MCK61620302	Cover,TV	411A	6411JK1006A	Power Cord Assembly
155B	4980JJ1010A	Supporter,Cover TV	412A	EAD59672202	Harness Assembly
158A	3550JJ2027A	Cover,Lamp	412B	EAD59741301	Harness Assembly
158E	3550JJ2017C	Cover,Lamp	412D	6877JK2011D	Harness Assembly
167B	4890JL1002V	Shelf,Glass	418A	5300JK1003J	Heater,Sheath
170A	3391JJ2004H	Tray Assembly,Meat	420A	4681JB1029J	Motor,DC
200A	ADC71006707	Door Assembly,Freezer	501A	EBR41531308	PCB Assembly,Main
201A	ADD71006807	Door Foam Assembly,Freezer	501B	EBR59400501	PCB Assembly,Display
203A	4987JJ1004X	Gasket Assembly,Door	501C	6871JB2074F	PCB Assembly,Display
205A	5004JJ1017B	Basket,Door	501F	3551JJ1020A	Cover Assembly,PCB
205B	5004JJ2002A	Basket,Tilt	503G	MCR61620401	Decor,Control
205C	5004JJ2003A	Basket,Tilt	600A	5989JA0002P	Ice Maker Assembly,Kit
205D	5004JJ1024A	Basket,Door	600C	MEA32865501	Guide,Tube
210A	4620JJ2009B	Stopper,Door	602A	4931JA3005B	Holder Assembly,Bracket
210B	4974JA3031B	Guide,Stopper	611E	5231JA2005E	Filter Assembly,Head
212G	4140JD1031A	Name Plate	615A	MJM61842001	Tank,Water
230A	ADC71006922	Door Assembly,Refrigerator	616B	5210JA3030W	Tube,Plastic
231A	ADD72914402	Door Foam Assembly,Refrigerator	616C	5210JA3030Y	Tube,Plastic
233A	4987JJ1004Y	Gasket Assembly,Door	616D	AJR72929601	Tube Assembly,Inject
241A	3550JL2003M	Cover,Tray	616E	5211JA2003C	Tube Assembly,Inject
241B	5004JJ1036A	Basket,Door	616F	MJU61929202	Tube,Plastic
241C	AAP72909002	Basket Assembly,Door	618A	5210JJ3006B	Tube,Inject
241D	5004JJ1025A	Basket,Door	619A	5220JA2009B	Valve,Water
241E	5004JJ1038A	Basket,Door	619B	3550JJ2024A	Cover,Valve
262A	4930JA3093A	Holder,Bracket	619C	AJU55759302	Valve Assembly,Water
262D	4004JA3002A	Clip	619D	MCK61866101	Cover,Valve
276B	MBG60108803	Button,Lever	621B	4932JA3002F	Connector,Tube
276C	MCR60014803	Decor,Dispenser	621C	MCD38280803	Connector,Tube
276D	MCK62049601	Cover,Front	621D	MJU60108902	Tube,Inject
279A	MBN60007701	Case,Display	622B	MJH61841901	Supporter,Tube Guide
279B	MCK60008103	Cover,Dispenser	623C	4770JA3001A	Band
280A	ACQ74487302	Cover Assembly,Dispenser	627B	4930JA3091A	Holder,Bracket
280F	MFC60678401	Lever,Dispenser	628C	5220JB2001A	Valve,Water
281A	3550JJ2013C	Cover,Hinge	630K	4970JA3022B	Spring,Plate
281B	4775JJ2003B	Hinge Assembly,Upper	903D	6500JK1003A	Sensor,Temperature
281E	5006JJ3003E	Cap,Hinge	B01	J351-00004L	Screw,Customized
282B	4775JJ2002A	Hinge Assembly,Center	B03	J351-00004P	Screw,Customized
282E	5006JJ2001F	Cap,Hinge	S01	4J00415D	Screw,Customized
282H	5006JJ3004E	Cap,Hinge	S14	3J05696W	Screw,Customized
283B	AEH72914701	Hinge Assembly,Lower	S20	4001JA3001A	Screw Assembly
283F	4620JJ2007A	Stopper,Door	S22	J471-00001J	Screw,Customized
284A	3550JJ2023A	Cover,Grille Fan	S24	1SZZJA3011B	Screw,Customized
284C	5006JA3080A	Cap,Screw	S28	1SZZJJ3005E	Screw,Customized
286A	4984JJ3003A	BUSH	S29	4J00415D	Screw,Customized
301A	5421J0002A	Evaporator Assembly	S31	4000W4A003A	Screw,Customized
304A	3551JJ2008B	Cover Assembly,Machinery(Rear)	S38	4J00415D	Screw,Customized



*'You Can Count on me . . .
to Work Safely.'*