



# Dehumidifier Users manual



**For Models:  
DH45S  
DH65S**

## FORWARD

The appearance of the units that you purchase might be slightly different from the ones described in the Manual, but will not affect proper operations and usage.

Please read carefully the sections corresponding to the specific model you choose, and keep the Manual in a safe place for reference.

### Attention:

- (1) Keep small children away from Dehumidifier.
- (2) Do not modify or otherwise defeat the plug.
- (3) The appliance shall be installed and operated in accordance with National Electrical Code regulations.
- (4) Do not operate the machine when the ambient temperature is below 35°F or above 102°F.
- (7) If the supply cord is damaged, it must be replaced by a qualified person in order to avoid a hazard.



## Contents

Safety precautions	1
Electrical Requirements	3
Choosing the Proper Location	3
Operation	4
Automatic shut off	7
Emptying the water tank	7
Maintenance	8
Troubleshooting	9
Specifications	11
Warranty	12

# SAFETY PRECAUTIONS

## READ ALL INSTRUCTIONS BEFORE USING.

To prevent injury to the user or other people and property damage the following instructions must be followed.  
Incorrect operation due to not following instructions will cause harm or damage. The seriousness is classified by the following indications.

 <b>WARNING</b>	 <b>CAUTION</b>
This symbol indicates the possibility of death or serious injury.	This symbol indicates the possibility of injury or damage to property only

### **WARNING**

Follow all grounding and electrical requirements on page 3

Disconnect power cord from receptacle prior to servicing or cleaning.

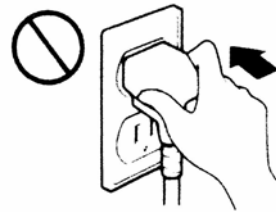

Do not use flammable fluids, solvents, or strong detergents to clean the Dehumidifier.

When cleaning the outside surfaces of the unit do not plug the unit into the receptacle until it is completely dry.



Do not use the water collected in the water tank for drinking or cooking purposes.

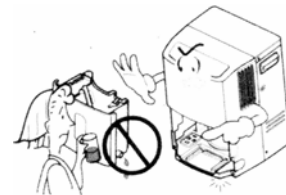

Do not clean the dehumidifier while it is plugged in. This can cause electrical shock.

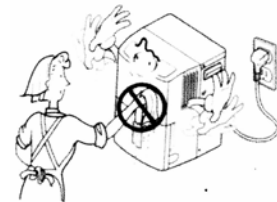

# SAFETY PRECAUTIONS



## CAUTION

Unit can fall if placed on a shelf or table. Be sure to secure Dehumidifier to prevent injury or damage from falling unit. Shelf or table must be able to support the weight of the unit and a full water tank (about 90 lbs).

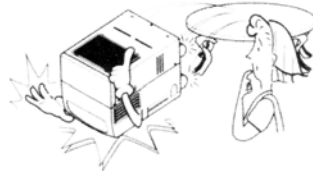

Replace water tank after emptying to prevent water damage to property and unit.

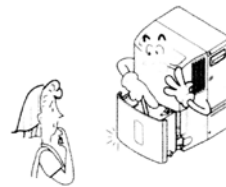

Do not operate unit with wet hands.  
Remove power from unit when it is to be cleaned.

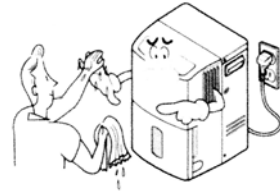

Close all doors and windows to the room where the dehumidifier is to be operated. Dehumidifier will be more effective in enclosed areas. Do not operate the Dehumidifier in areas where the temperature will drop below 65° F.

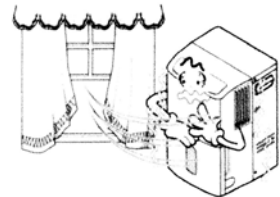

Allow proper clearance for unit when operating. Minimum clearance on sides and back is 20”.

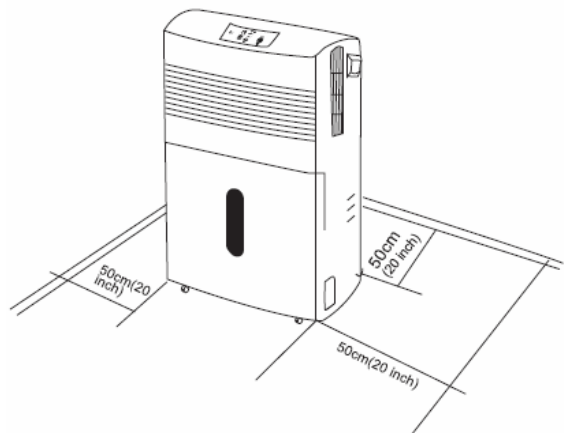

# ELECTRICAL REQUIREMENTS



## WARNING

OBSERVE ALL LOCAL ORDINANCES.

- **DO NOT, UNDER ANY CIRCUMSTANCES, REMOVE THE POWER SUPPLY CORD GROUND PRONG. ELECTRICAL GROUND IS REQUIRED ON THIS APPLIANCE.**
- **USE ONLY UL APPROVED EXTENSION CORD. DO NOT ALLOW WATER OR MOISTURE TO ENTER ELECTRICAL CONNECTIONS.**

**Properly grounded electrical supply is required time delay fuse or time delay circuit breaker is recommended. Use a dedicated circuit, serving only this appliance.**

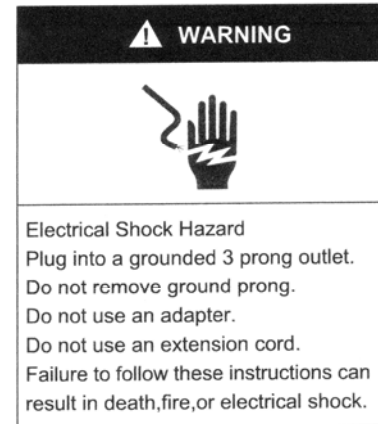

For your personal safety, this appliance must be grounded. This appliance has a power supply cord with a grounding plug. To minimize possible shock hazard, the cord must be plugged into a mating grounding type wall receptacle and grounded in accordance with the National Electrical Code latest edition and all local codes and ordinances. If a mating wall receptacle is not available, it is the personal responsibility and obligation of the customer to have a properly grounded wall receptacle installed by a qualified electrician.

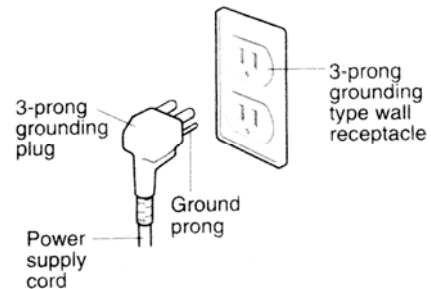

## CHOOSING THE PROPER LOCATION

- Use the dehumidifier in a basement to help prevent moisture damage.
- Use the dehumidifier to prevent moisture damage anywhere books or valuables are stored.
- Put the dehumidifier in a flat location where the air outlets cannot be covered.
- Place the unit no less than 20 inches away from a wall or other obstacle.

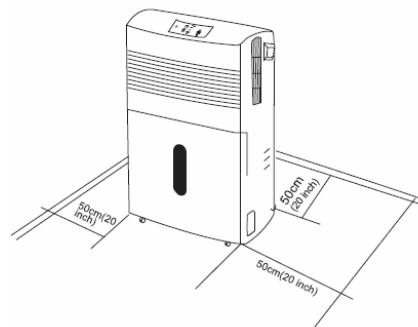

# OPERATION



## WARNING

TO REDUCE THE RISK OF FIRE, ELECTRIC SHOCK, OR INJURY TO PERSONS, READ THE IMPORTANT SAFETY INSTRUCTIONS BEFORE OPERATING THIS APPLIANCE.

- 1. Control panel
- 2. Front grille
- 3. Power cord
- 4. Cabinet
- 5. Air filter
- 6. Water bucket

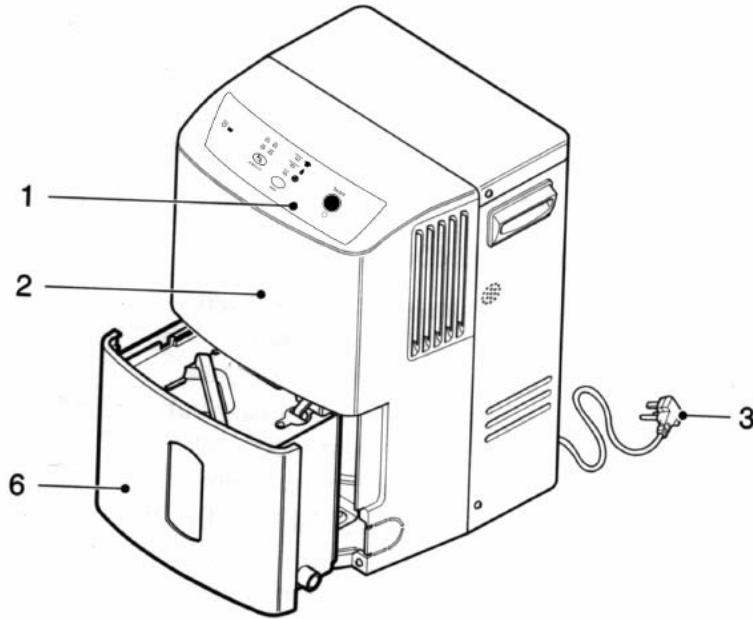

## IMPORTANT:

When unit is first plugged in or after a power outage, there will be approximately a **2 minute delay** before operation begins. Operation resumes at previous settings.

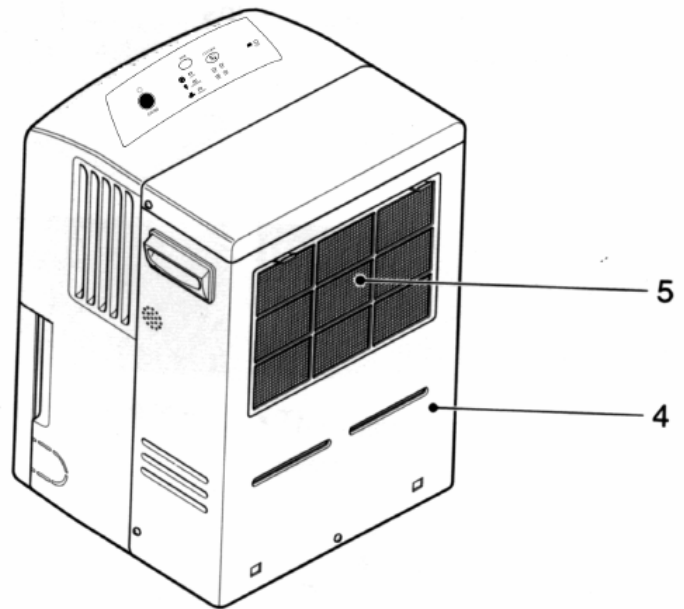

# OPERATION

## CONTROL PANEL

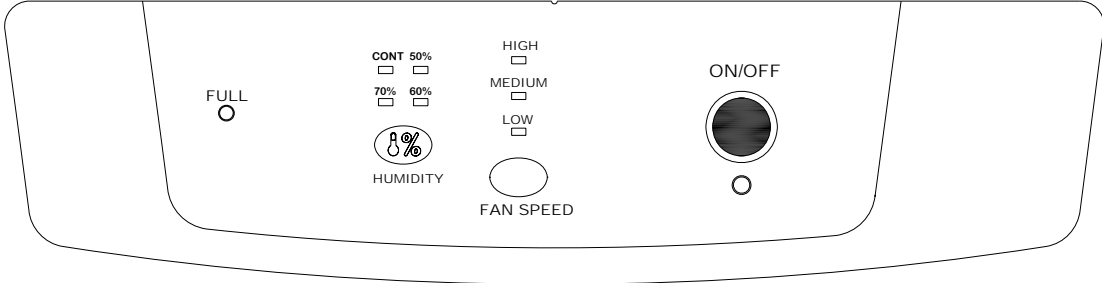

**Indication Lights**

**(POWER) Indication Light:**

When unit is first plugged in, this light will be illuminated.

**(FULL) Indication Light:**

When this light flashes, it indicates that the water tank is full, or that the installation position of the water tank is not correct. In this case, the water in the tank should be emptied or the water tank should be re-installed correctly.

**Fan Speed Light:**

When the High, Medium or Low indication light is on, it shows the Fan Speed selected.

**(50%, 60%, 70%) Humidity Indication Lights:**

When the indication light of 50 %, 60%, or 70 % is illuminated, it shows the corresponding Relative Humidity that has been chosen.

**(CONT)Continuous Dehumidifying Indication Light:**

When this light is on, it shows the unit is in the continuous dehumidification mode.

Humidity Indicator	Range of Relative Humidity
50%	<60%
60%	60%-70%
70%	>70%

## BUTTON FUNCTIONS

**ON/OFF:** Press button once to start unit. Press again to turn off.

**HUMIDITY:**

Pressing this button sets the humidity percentage I.E. 50%, 60%, 70%, and CONT. The corresponding indication light will be illuminated.

When the unit is turned on, the unit will start in the CONT (continuous dehumidifying) mode. The unit will automatically switch off when the water tank is full or the power is turned off.

When the ambient humidity is lower than the set Relative Humidity, the unit will automatically stop operation.

# OPERATION

## OPERATIONAL PROCEDURES:

### Connecting the power

- Firmly plug into the socket to ensure no hazard of electric shock or fire.
- Use caution to not damage the power cable or plug.
- When the power is properly connected, the power indication light will be illuminated.

### Open the Air Guide

- Before the unit is switched on, verify that the air guide is open.
- Adjust the air guide to the angle you want.

### Switching Operational Modes

Press the ON/OFF button and the unit will automatically start the operation in the CONT (continuous) mode.

- **HIGH:** Press the Fan SPEED button until the indication light for this speed is illuminated. The unit will start operating and the air outlet volume will be in High level, which is suitable for strong dehumidification.
- **MEDIUM:** Press the FAN SPEED button until the indication light for this speed is illuminated. The unit will start to operate and the air outlet will be in the Medium level.
- **LOW:** Press the FAN SPEED button until the light for this speed is illuminated. The unit will start operating and the air outlet will be in the low level, which will reduce the noise level and dehumidifying operation. If the room temperature is and humidity is high, PLEASE avoid this selection, as it may reduce the life of the unit.

### NOTE:

When the room temperature is below 50°F or above 95°F the unit will only operate in HIGH FAN SPEED (the air outlet volume will be in the "high" level). Pressing the FAN SPEED button will not change the fan speed .

### STOPPING OPERATION

During operation, press the On/off button.-the dehumidifier will stop operating.

**DO NOT ATTEMPT TO TURN OFF THE UNIT BY UNPLUGGING THE UNIT. USE ON/OFF POWER BUTTON TO TURN THE UNIT OFF, THEN UNPLUG IF DESIRED.**

**A 3 minutes delay will occur when the unit's compressor turns off for any reason.**



# AUTOMATIC SHUT-OFF

## AUTOMATIC SHUT-OFF

When the tank is full, or when the tank is not in the proper position, the FULL light will illuminate and the unit automatically shuts off.

Also, when bucket is out of position, the unit will beep 3 times. Dehumidifier will not operate if tank is not in the proper position, and the TANK FULL light will be illuminated.

## REMOVING AND EMPTYING THE WATER TANK

### Caution:

If the tank is taken out during the operation process or when the unit has just stopped operating, the condensed water might drop to the base plate, it is recommended to take out the bucket for emptying when the unit has stopped operating for some time to prevent the condensed water from spilling into the unit.

### To empty the tank manually

When the tank is full, remove and empty it into a large sink or tub.

When finished, replace tank into unit.

### NOTE:

Use care removing bucket as it can be heavy. Carry bucket by supporting it from the bottom.

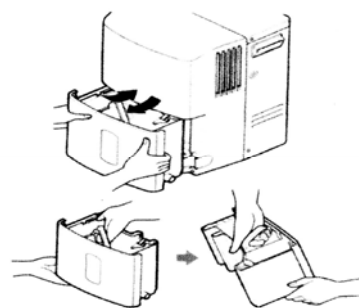

## Permanent Drainage

The bucket has a threaded hose connection which can be attached permanently.

Remove cap on side of tank and attach a section of hose to the threaded connection and direct to desired area, or drain.

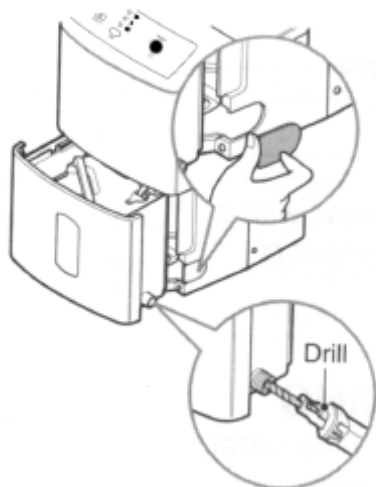

# MAINTENANCE

## GRILL AND CASE

**To clean the case:** use water and a mild detergent. Do not use bleach or an abrasive cleaner.

**To clean the grill:** use a vacuum with an attachment or brush.

## AIR FILTER

The air filter is on the back of the dehumidifier. It should be checked and cleaned at least every 2 weeks or more often if necessary.

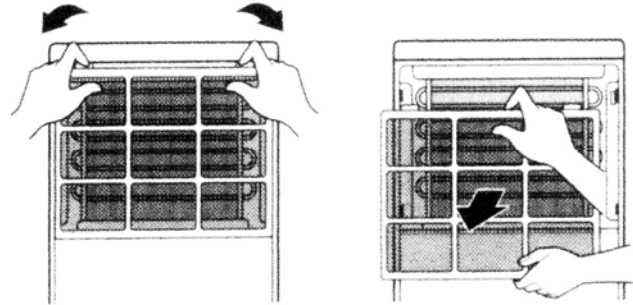

### TO REMOVE:

- Pull out the air filter by pressing the filter hooks, then release two tabs at the bottom side of the filter.
- Wash air filter with warm water and a mild detergent. Rinse and let dry. Once completely dry, re-install filter.

## CLEANING INSIDE THE UNIT

After removing the air filter, clean the coil on the inside of the unit with a soft brush to remove any dirt that may have accumulated.

### NOTE:

- Do not allow water to enter the electrical, machine compartment through the circular opening behind the coil.
- DO NOT SPRAY THE COIL WITH A HOSE.
- USE CAUTION WHEN CLEANING, THE COIL HAS SHARP EDGES

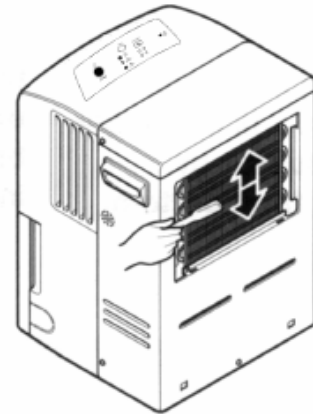

## GENERAL CLEANING

Dust the front grill and the side panels with a soft brush or use the dusting attachment of your vacuum.

## CLEANING THE WATER TANK

Every few weeks, rinse the inside of the water tank with a mild detergent to prevent growth of mold, mildew, and bacteria



# TROUBLESHOOTING

**USE THE CHART BELOW TO DETERMINE OPERATIONAL ISSUES THAT MAY NEED SERVICE**

TROUBLESHOOTING CHART		
PROBLEM	CAUSES	SOLUTIONS
Dehumidifier does not start	Power cord is unplugged	Verify that outlet is working, and that plug is firmly plugged into the outlet
	Blown fuse or circuit breaker	Check and replace/reset circuit breaker
	water tank is full	Empty water tank and replace
	Water tank is not installed properly	Verify that water tank is installed properly
Dehumidifier does not dry the air as well as it should	Unit was not allowed enough time to remove moisture	Allow at least 3-4 days to maintain a desired dryness level.
	Airflow is restricted	Make sure intake louvers aren't blocked, and have proper clearances
	Doors and windows may not be closed tightly	Check that doors, windows, and other openings are securely closed.
	Humidity may be entering the room via other sources I. E. Clothes dryer, etc.	Look for sources of Humidity and correct if necessary
	Ambient temperature to low or too high	This is normal. Protection circuits in the unit prevent operating the unit under unfavorable conditions.
Fan Noise	Air is moving through the Dehumidifier	This is normal
Water leakage	Tank Drain hose may be loose	Check hose connection and tighten if necessary
	Water Tank not installed properly	See removing and emptying the water tank on page 7.

# TROUBLESHOOTING

**THE FOLLOWING ISSUES ARE NOT DEFECTS OR MALFUNCTIONS OF THE UNIT.**

<b>OPERATIONAL ISSUES</b>	
<b>ISSUE</b>	<b>CAUSES</b>
Excessive noise	Compressor starting up, changing modes
Humidity does not drop	Room too large for unit to effectively operate.
Poor dehumidification	room relative humidity is too low
Musty odors emanating from the unit when first turned on	High temperatures of the heat exchanger may cause strange odors
Stains in the water tank	Sometimes stains are left due to factory testing.
Unit only works in High mode	When the ambient temperature is below 50°F or above 95°F the protection devices of the unit prohibit operation in other modes
Fan motor is operating but compressor fails to start	Compressor time delay may have been activated. 3 minutes is required to allow the compressor to stabilize its working pressures before being able to restart

# SPECIFICATIONS

<b>SPECIFICATIONS</b>		
<b>MODEL</b>	<b>DH45S</b>	<b>DH65S</b>
Capacity	45 PINTS/DAY	65 PINTS/DAY
Rated Frequency	60 Hz	60 Hz
Rated Voltage	115VAC	115VAC
Rated Current Input	5.5 A	9.0 A
Rated Input	640W	1050 W
Refrigerant/Wt	R22/ .56 LB	R22/ .62 LB
Weight(net)	44.3 LBS	50.3 LBS
HP. PSIG	319 PSI	377 PSI
LP. PSIG	145 PSI	145 PSI

**PRODUCT SPECIFICATIONS SUBJECT TO CHANGE WITHOUT NOTICE**

# WARRANTY

International Refrigeration Products warrants that the product supplied is free from defects in material and workmanship. This warranty is valid as long as this product is properly handled, installed, operated and serviced in accordance with the Installation and Operating Instructions shipped with this unit, and warranty card is completed and mailed no later than 30 days after date of purchase. All warranty claims must be made within one(1) year (five (5) years for compressor) from date of purchase (unless national regulations require a longer registration period).

This warranty provides free replacement of defective parts only. Labor and replacement as a result of normal wear and tear are not covered under this warranty.

Additional claims are excluded, unless required by national regulations. International Refrigeration Products Inc. is not responsible for incidental, consequential, direct, or indirect damages, or expenses relating to the use of, or the inability to use the product for any purpose. Other implied warranties are excluded.

This constitutes International Refrigeration Products' warranty obligation and replaces any and all prior warranties for this product.

INTERNATIONAL REFRIGERATION PRODUCTS INC.  
11325 Nations Ford Rd. Charlotte, NC 28134-8393  
(704)504-8590 Phone (704)504-3023 Fax