

This Owner's Manual is provided and hosted by [Appliance Factory Parts](#).

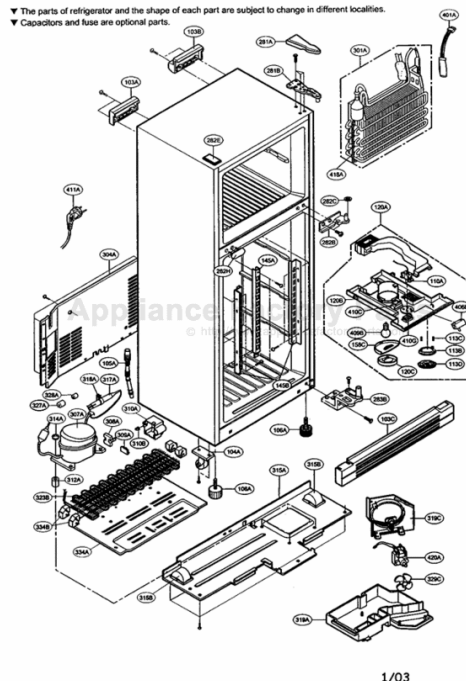

# LG LRTG2011W Owner's Manual

[Shop genuine replacement parts for LG LRTG2011W](#)



[Find Your LG Refrigerator Parts - Select From 834 Models](#)

----- Manual continues below -----

# SERVICING PRECAUTIONS

## AIR RECHARGING IN COMPRESSOR

Test the refrigeration system connecting it electrically before refilling operation. It is necessary to ascertain the function of the motor-compressor and identify the defects immediately. If defects have been found, empty the old system of possible R-134a residue by breaking off the end of the extension piece at its narrow point. (Figure 1)

Replace the filter and any damaged components. Unsolder and pull off the piece remaining inside the service tube and then attach an complete extension with male Hansen and at last, solder it to the same tube again. (Figure 2)

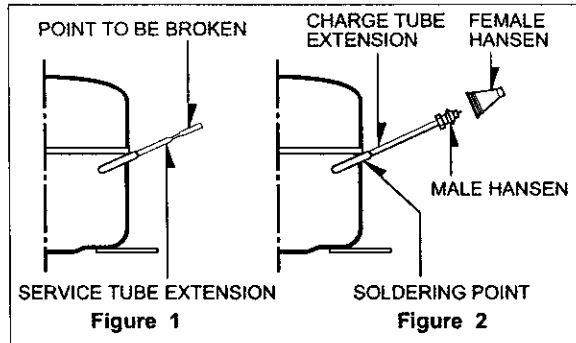

It is necessary to execute the soldering operation with valve open so that the fumes caused by oil residue can come out freely without blowholes between two tubes during the heating of the point to be soldered.

The extension fitted with the male Hansen is connected to the female fitting of the vacuum pump tube. (Figure 3)

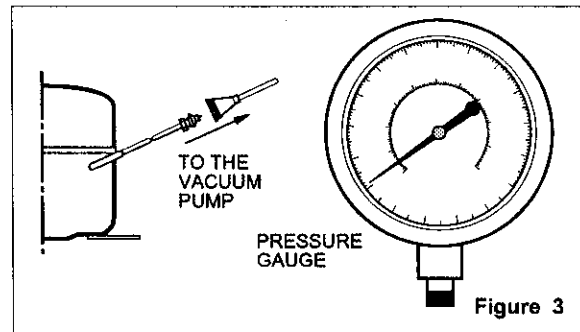

Air evacuating from the system begins as soon as the pump starts. The refrigeration system must be kept under vacuum until the reading on the low-pressure gauge indicates vacuum (0 absolute, -1 atm., -760 mm hg). In any case it is advisable to keep the pump running for about 30 minutes. (Figure 3)

If considerable leakage occurs, it will be necessary to stop the vacuum pump and to add a small quantity of Freon to the system. If vacuum should not be obtained (pressure gauge can't fall to 1 atmosphere), start the refrigeration unit and find the leakage with special leak-finder. When the defective soldering point is visible, repair it after opening the extension tube valve and reestablishing the normal outside pressure inside the group.

Because the melted alloy is sucked into the tubes and blocks them, the pressure must be rebalanced when vacuum is in the system when soldering. As soon as the

vacuum operation is over, add the quantity in grams of R-134a to the refrigeration system. Remember that every system has an exact quantity of R-134a that can be added with a tolerance of  $\pm 5$  grams. (Figure 4)

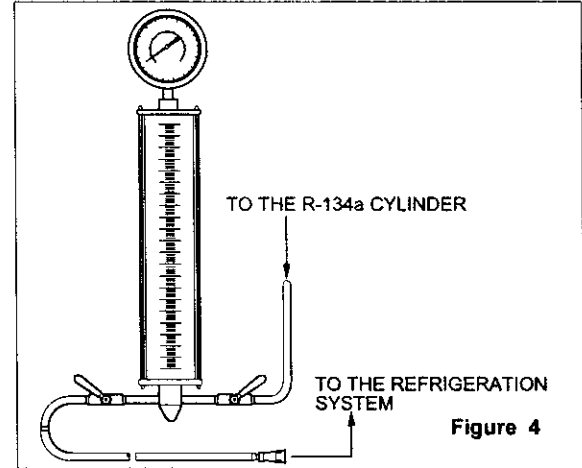

Before performing this operation (if the vacuum pump and refilling cylinder are connected), make sure that the valve placed between the vacuum pump and the refilling tube is closed in order to keep the Freon for addition to the system. (Figure 5)

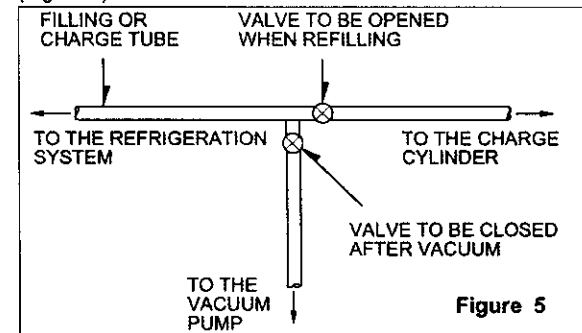

In addition, check the graduated scale on the cylinder for the quantity of R-134a to be added, for example, if we have 750 grams of Freon in the cylinder and must add 140 grams to the group, this amount will be reached when R-134a has dropped to 610 grams, remembering that the indicator shows a lower limit of meniscus. Do this after choosing the scale corresponding to the gas pressure indicated by the pressure gauge on the top of the column. To make R-134a flow into the system, open the valve placed at the base of the cylinder connected to the filling tube. The amount of Freon cannot be added to the system all at once because it may cause a blocking of motor-compressor. Therefore, proceed by adding the original quantity of about 20-30 grams and close the valve immediately.

The pressure rises and the motor compressor must start sucking the gas and lowering the pressure again. Open the valve again, maintaining the same manner until reaching to the quantity of R-134a established for the system being charged. When the system is running, the suction pressure must be stabilized between 0.30 to 0.6 (0.10 to 0.4) atmosphere.

# CIRCUIT DIAGRAM

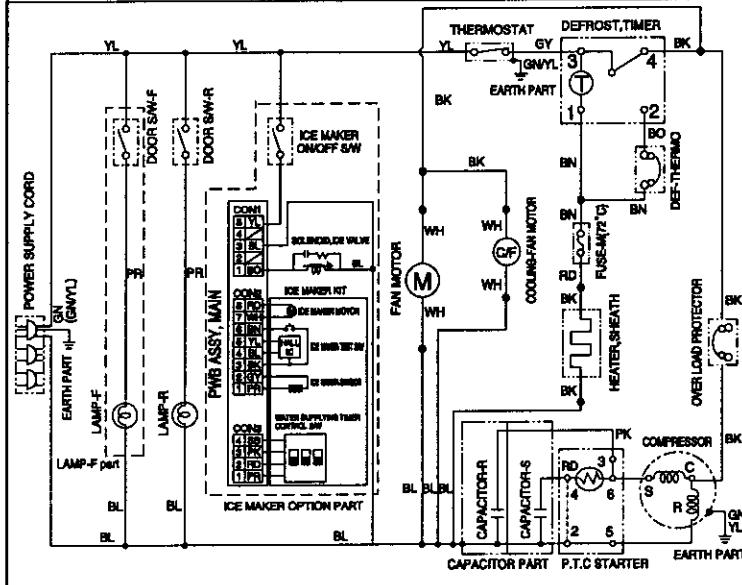

\* LAMP-F PART, CAPACITORS, THE PLUG TYPE, EARTH PART AND ICE MAKER OPTION PART ON CIRCUIT DIAGRAM ARE SUBJECT TO CHANGE IN DIFFERENT LOCALITIES.

WH: WHITE    BL: BLUE    RD: RED    GY: GRAY/PURPLE    YL: YELLOW    BO: BRIGHT ORANGE  
 BK: BLACK    BN: BROWN    PR: PURPLE    PK: PINK    GN: GREEN

## WATER SUPPLYING TIME CONTROL OPTION

▶ CAUTION : Please unplug the power cord from the wall outlet.

SWITCH NO			TIME
SW1	SW2	SW3	
OFF	OFF	OFF	10.5 sec
ON	OFF	OFF	9 sec
OFF	ON	OFF	10 sec
ON	ON	OFF	11 sec
OFF	OFF	ON	12 sec
ON	OFF	ON	13 sec
OFF	ON	ON	14 sec
ON	ON	ON	15 sec

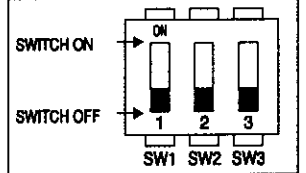

3854JD1046C

## 2. PARTS IDENTIFICATION

### FREEZER COMPARTMENT

Freezer Shelf

General Type  
Ice Tray

Ice Cube Box

Freezer Temperature  
Control Dial

### REFRIGERATOR COMPARTMENT

Temperature  
Control Dial

Lamp

Shelves

Snack Corner

Crisper  
Used to keep fruits  
and vegetables  
fresh and crisp.

**Base Grille**  
Push the grille toward  
the refrigerator  
until it snaps  
into place.

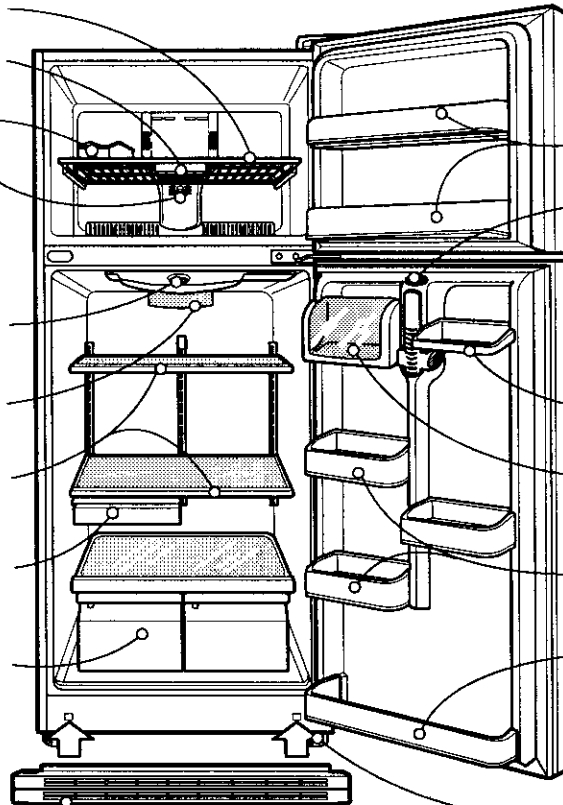

Freezer Door Bin

**Door Cooling**  
On the refrigerator door,  
the cold air passageway is  
installed to supply  
cold air to the doorside of  
the refrigerator  
compartment.

Can Server

Dairy Corner

Adjustable  
Door Bin

Refrigerator Door  
Rack

Leveling Screw  
(Inside)

# 3. DISASSEMBLY

## 3-1 DOOR

### ● Freezer Door

1. Remove the hinge cover by pulling it upwards.
2. Loosen hexagonal bolts fixing the upper hinge to the body and lift the freezer door.

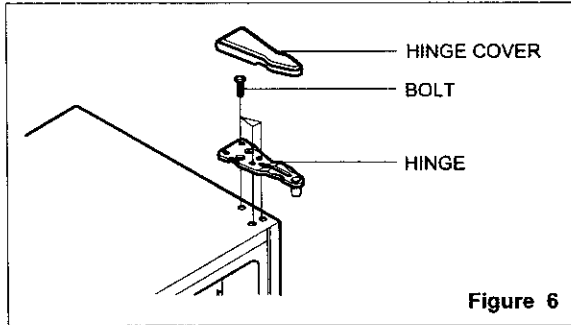

3. Pull out the door gasket to remove from the door foam assembly.

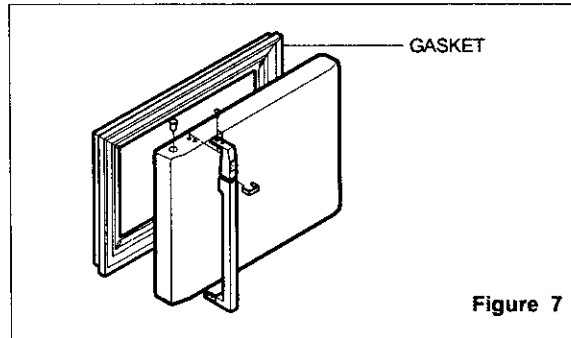

### ● Refrigerator Door

1. Loosen hexagonal bolts attaching the lower hinge to the body to remove the refrigerator door only.

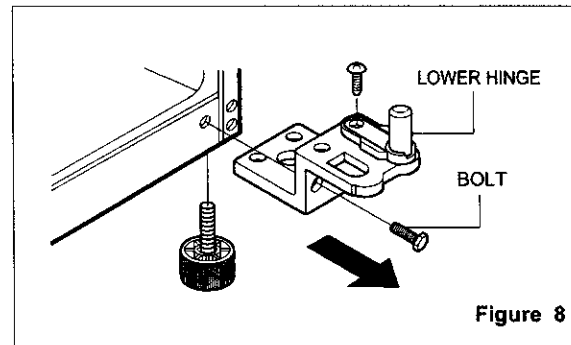

2. Pull out the door gasket to remove from the door foam assembly.

## 3-2 DOOR SWITCH

1. To remove the door switch, pull it out with a slotted type driver as shown in (figure 9).
2. Disconnect the lead wire from the switch.

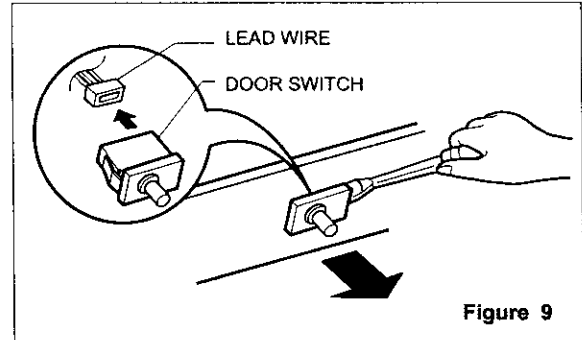

## 3-3 THERMOSTAT

1. Remove Control Box-R by loosening 2 screws attached to ceiling of Refrigerator compartment (Figure 10)
2. Separate the thermostat and dial knob F.
3. Remove the thermostat by disconnecting the lead wire.

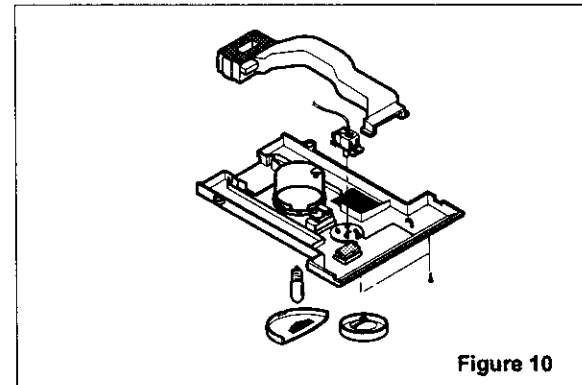

### 3.4 FAN AND FAN MOTOR

1. Remove the freezer shelf. (If your refrigerator have an Ice Maker, disassemble the Ice maker first)
2. Remove the grille by pulling it out and by loosening a screw.
3. Remove the Fan Motor assembly by loosening 4 screws and disassemble the shroud.
4. Pull out the fan and separate the Fan Motor and Bracket.

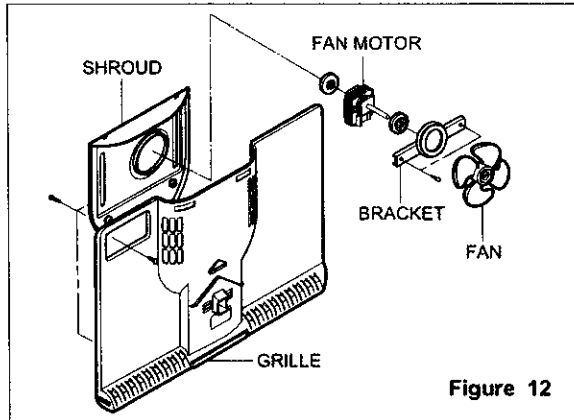

Figure 12

### 3-5 DEFROST CONTROL ASSEMBLY

Defrost control assembly consists of Defrost Thermostat and FUSE-M.

Defrost Thermostat functions to defrost automatically and it is attached to metal side of the Evaporator and senses Temp.

Fuse-M is a safety device for preventing over-heating of the Heater when defrosting.

At the temperature of 77°C, it stops the emission of heat from the Heater.

1. Pull out the grille assembly.
2. Separate the connector connected with the Defrost Control assembly and replace the Defrost Control assembly after cutting the Tie Wrap. (Figure 14)

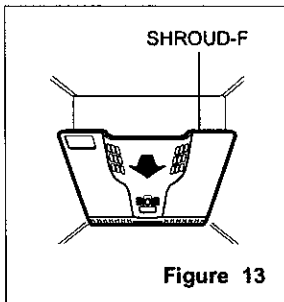

Figure 13

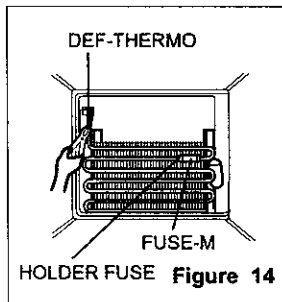

Figure 14

### 3-6 REFRIGERATOR ROOM LAMP

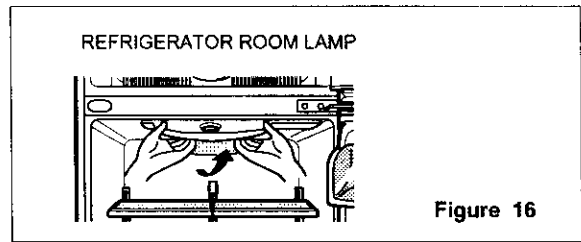

Figure 16

1. Unplug the power cord from the outlet.
2. Remove refrigerator shelves.
3. Release the hooks on both ends of the lamp shield and pull the shield downward to remove it.
4. Turn the lamp counterclockwise.
5. Assemble in reverse order of disassembly. Replacement bulb must be the same specification as original. (Max 40 W)

### 3-7 CONTROL BOX-R

1. First, remove all shelves in the refrigerator and Control Box-R by loosening 2 screws.

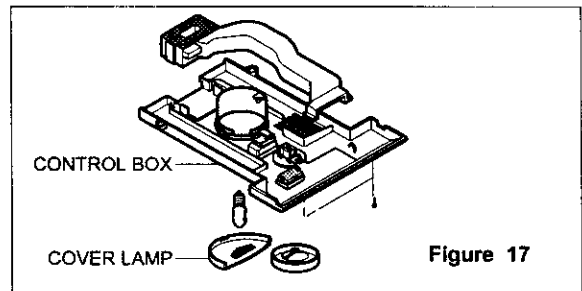

Figure 17

2. Remove the Control Box-R by pulling it downward.
3. Disconnect the lead wire on the right position and separate timer, thermostat, Lamp socket, etc.

# 4. ADJUSTMENT

## 4-1 COMPRESSOR

### 4-1-1 Role

The compressor intakes low temperature and low pressure gas evaporated from evaporator of the refrigerator, and condenses this gas to high temperature and high pressure gas, and then plays delivering role to condenser.

### 4-1-2 Composition

The compressor includes overload protection. The PTC starter and OLP (overload protector) are outside the compressor. Since the compressor is manufactured to tolerances of 1 micron, and is sealed in a dust - and moisture - free environment, use extreme caution when repairing it.

### 4-1-3 Note for Usage

- (1) Be careful not to allow over-voltage and over-current.
- (2) No Strike  
If applying forcible power or strike (dropping or careless handling), poor operation and noise may occur.
- (3) Use proper electric components appropriate to the Compressor.
- (4) Note to Keep Compressor.  
If Compressor gets wet in the rain and rust in the pin of Hermetic Terminal, the result may be poor operation and poor contact may cause.
- (5) Be careful that dust, humidity, and welding flux don't contaminate the compressor inside when replacing the Compressor. Dust, humidity, and flux due to welding which contaminates the cylinder may cause lockage and noise.

## 4-2 PTC-STARTER

### 4-2-1 Composition of PTC-Starter

- (1) PTC (Positive Temperature Coefficient) is a no-contact semiconductor starting device which uses ceramic material consisting of BaTiO<sub>3</sub>.
- (2) The higher the temperature is, the higher the resistance value. These features are used as starting device for the Motor.

### 4-2-2 Role of PTC-Starter

- (1) PTC is attached to Hermetic Compressor used for Refrigerator, Show Case, and starting Motor.
- (2) Compressor for household refrigerator applies to single-phase induction Motor.  
For normal operation of the single-phase induction motor, in the starting operation flows in both main coil and sub-coil. After the starting is over, the current in subcoil is cut off. The proper features of PTC play all the above roles. So, PTC is used as a motor starting device.

### 4-2-3 PTC-Applied Circuit Diagram

#### ● According to Starting Method for the Motor

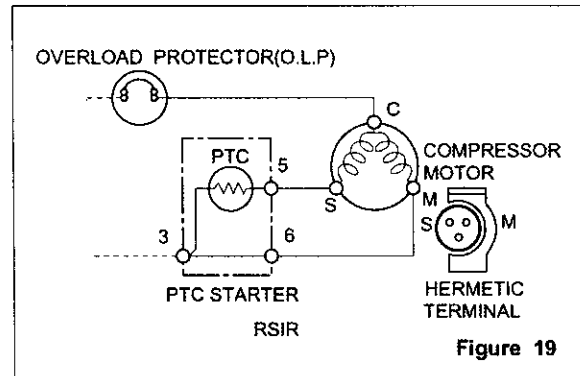

### 4-2-4 Motor Restarting and PTC Cooling

- (1) For restarting after power off during normal Compressor Motor operation, plug the power cord after 5 min. for pressure balance of Refrigerating Cycle and PTC cooling.
- (2) During normal operation of the Compressor Motor, PTC elements generate heat continuously. Therefore, if PTC isn't cooled for a while after the power has been shut off, the motor will not restart.

### 4-2-5 Relation of PTC-Starter and OLP

- (1) If the power is off during operation of Compressor and the power is on before the PTC is cooled, (instant shut-off within 2 min. or unplugging and reconnecting), the PTC isn't cooled and a resistance value grows. As a result, current can't flow to the sub-coil, the Motor can't operate, and the OLP operates by flowing over current in only in the main-coil.
- (2) While the OLP repeats on and off operation about 3-5 times, PTC is cooled and Compressor Motor performs normal operation.  
If OLP doesn't operate when PTC is not cooled, Compressor Motor is worn away and causes circuit-short and fire. Therefore, always use a properly attached OLP.

### 4-2-6 Note to Use PTC-Starter

- (1) Be careful not to allow over-voltage and over-current.
- (2) Do not strike  
Don't apply a forcible power or strike.
- (3) Keep apart from any liquid.  
If liquid, such as oil or water away enters the PTC, PTC materials may fail due to insulation breakdown of the material itself.
- (4) Don't change PTC at your convenience.  
Don't disassemble PTC and case. If the exterior to the PTC-starter is damaged, resistance value is altered and it may cause poor starting of the compressor motor may cause.
- (5) Use a properly attached PTC.

### 4-3 OLP (OVERLOAD PROTECTOR)

#### 4-3-1 Definition of OLP

- (1) OLP (OVERLOAD PROTECTOR) is attached to the Compressor and protects the Motor by cutting the current to the Motor if the temperature rises and activates the bimetal spring in the OLP.
- (2) When over-voltage flows to Compressor motor, the Bimetal works by heating the heater inside the OLP, and the OLP protects Motor by cutting off current which flows to the Compressor Motor.

#### 4-3-2 Role of the OLP

- (1) The OLP is attached to the Hermetic Compressor used for the Refrigerator and prevents the Motor Coil from being started in the Compressor.
  - (2) Do not turn the Adjust Screw of the OLP in any way for normal operation of the OLP.
- (Composition and connection diagram of OLP)

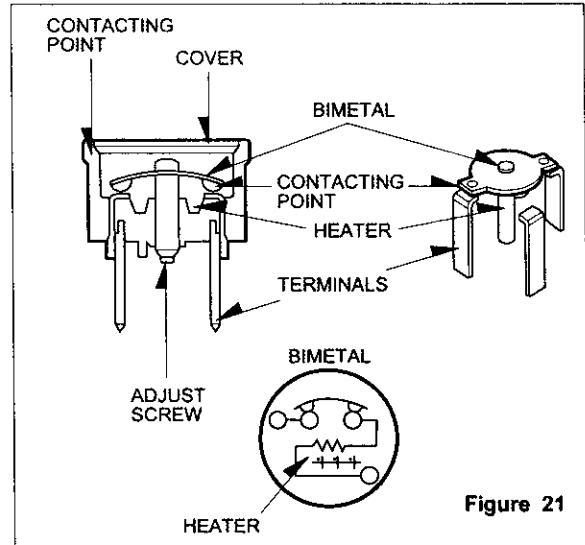
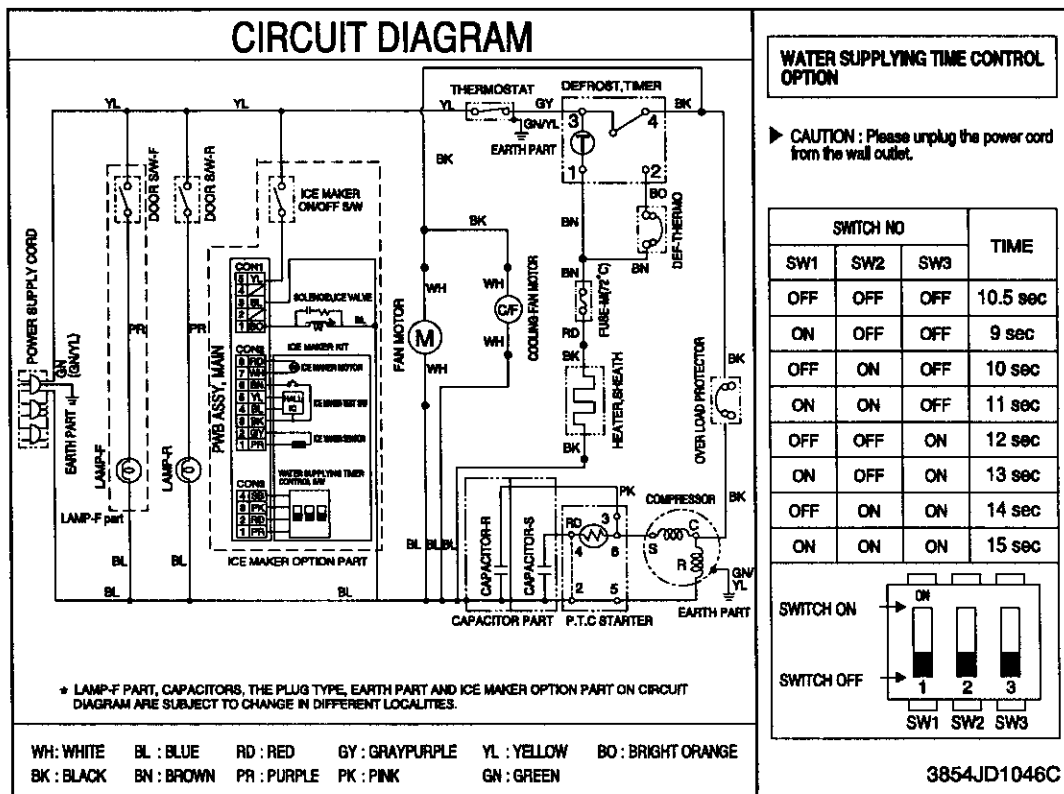

Figure 21

## 5. CIRCUIT DIAGRAM



# 6. TROUBLESHOOTING

## 6-1 COMPRESSOR AND ELECTRIC COMPONENTS

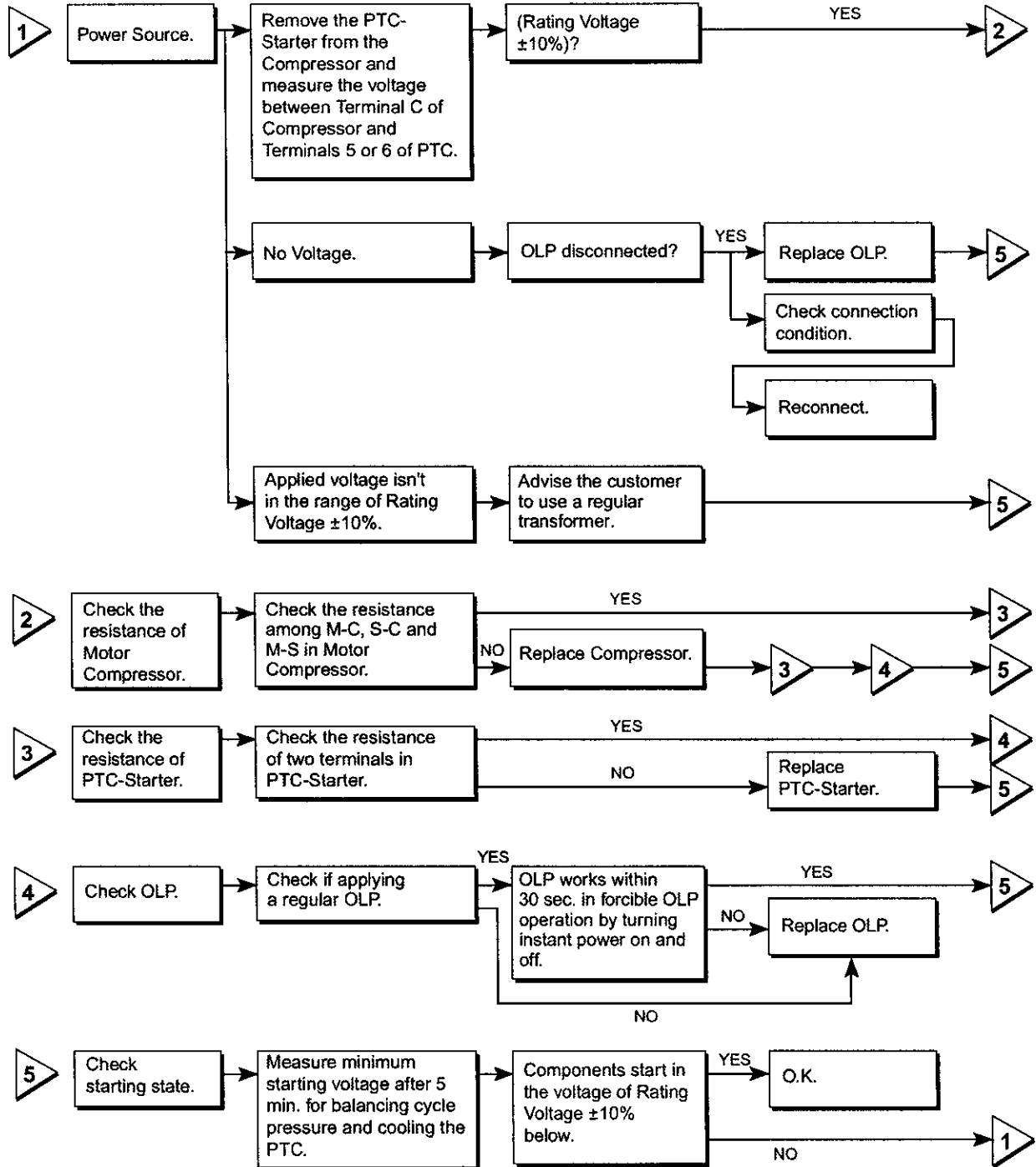

## 6-2 PTC AND OLP

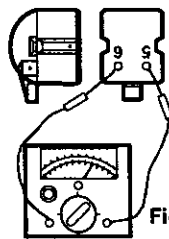
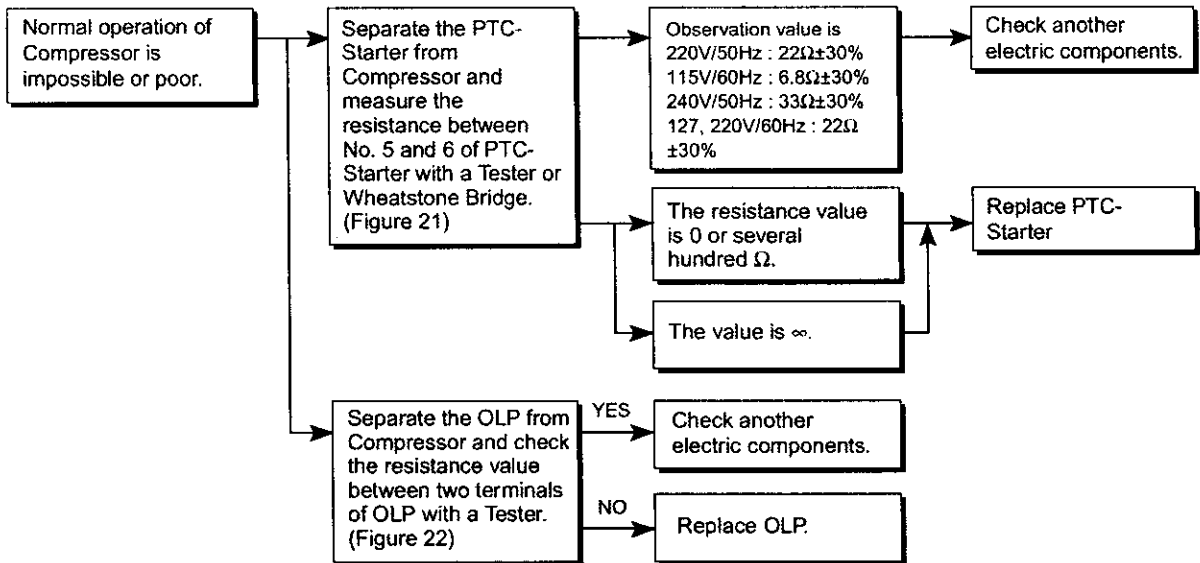

Figure 21

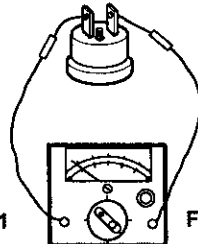

Figure 22

## 6-3 DEFROST TIMER

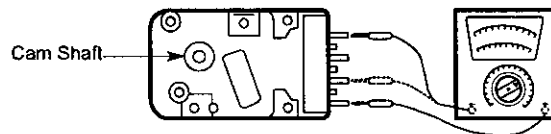
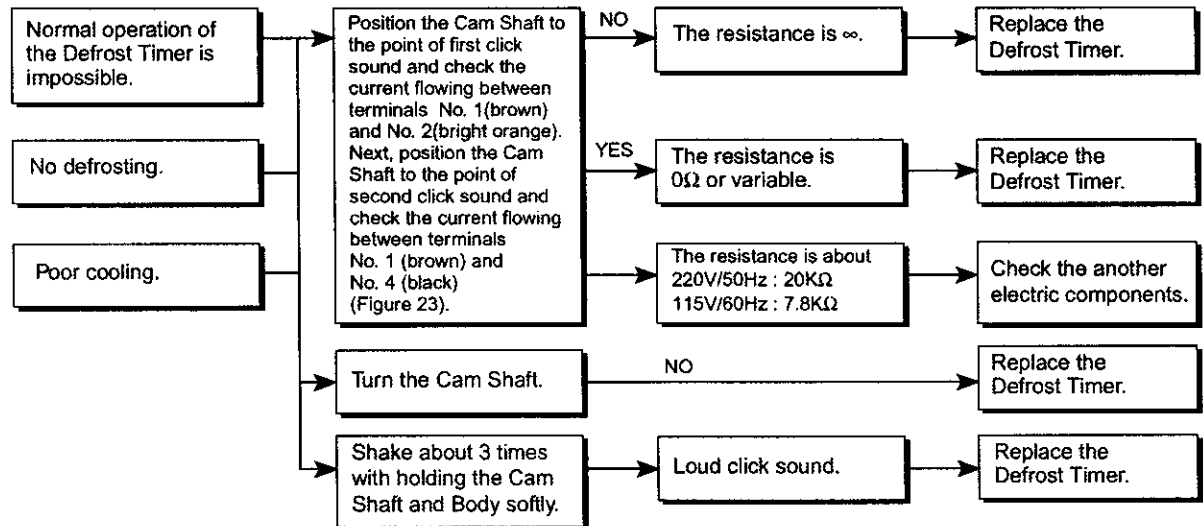
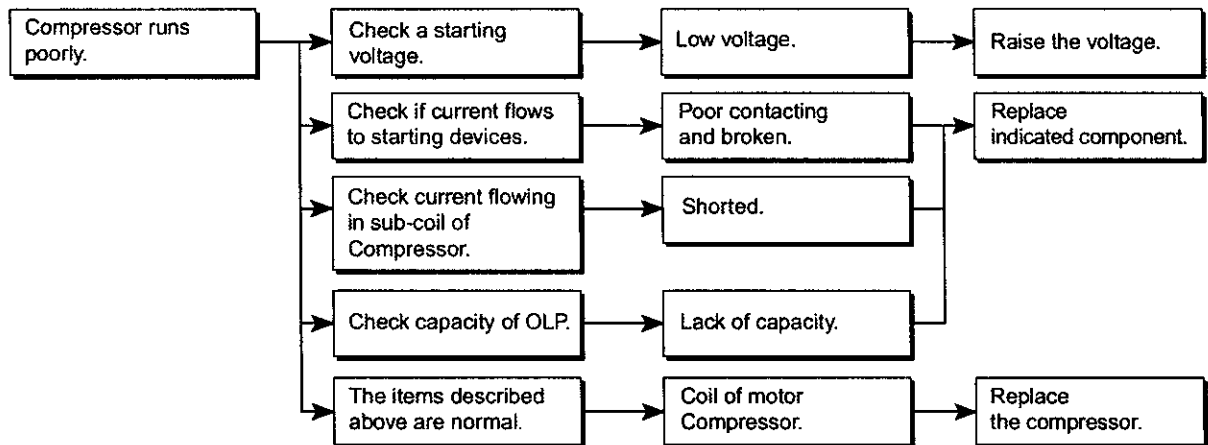
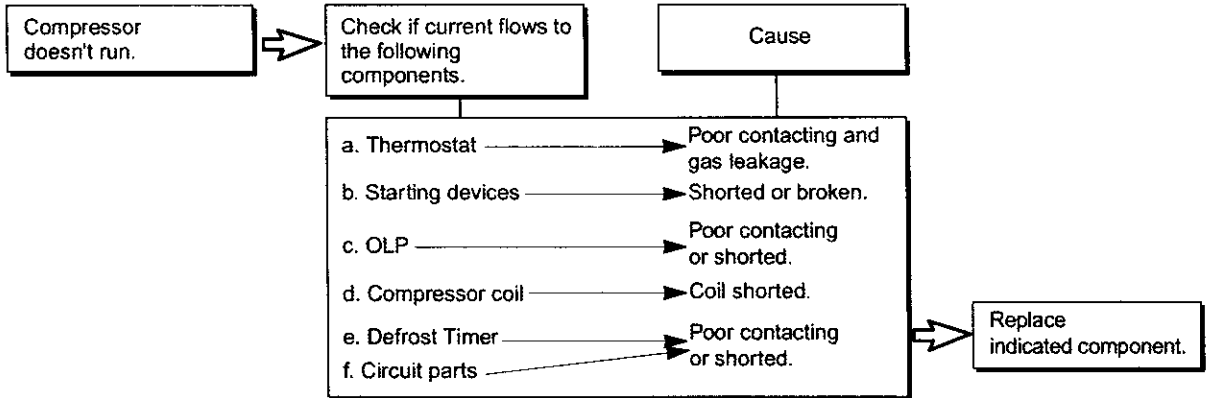

Figure 23

## 6-4 OTHER ELECTRIC COMPONENTS

### ▼ Cooling is impossible



### ▼ Cooling ability is poor

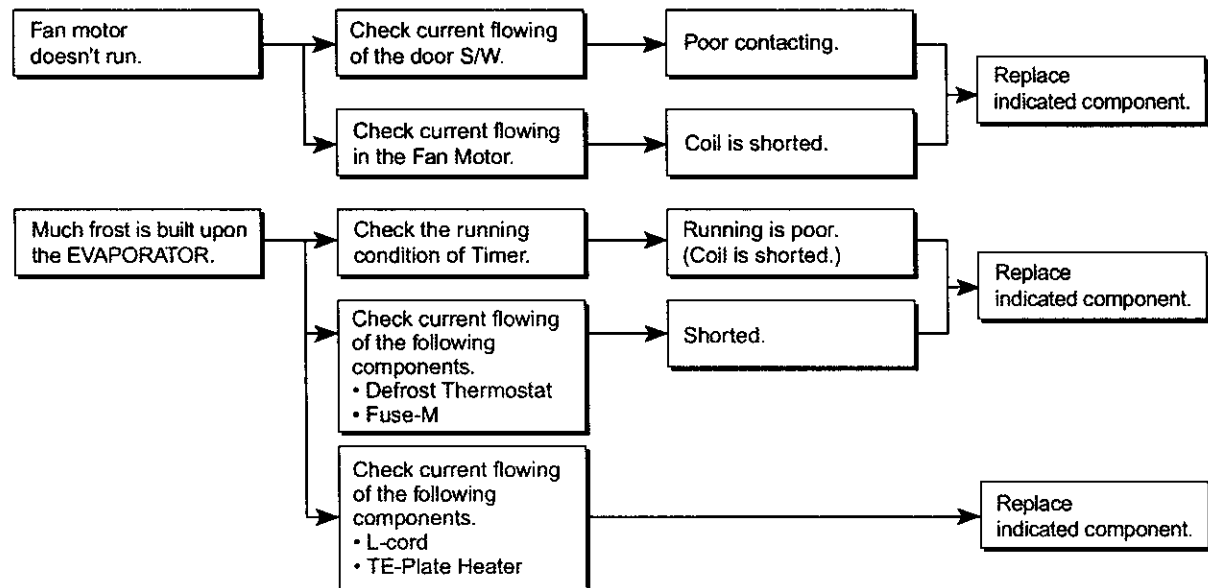

## 6-4 SERVICE DIAGNOSIS CHART

COMPLAINT	POINTS TO BE CHECKED	REMEDY
Cooling is impossible.	<ul style="list-style-type: none"> <li>• Is the power cord unplugged from the outlet?</li> <li>• Check if the power S/W is set to OFF.</li> <li>• Check if the fuse of power S/W is shorted.</li> <li>• Measure the voltage of power outlet.</li> </ul>	<ul style="list-style-type: none"> <li>• Plug to the outlet.</li> <li>• Set the switch to ON.</li> <li>• Replace fuse.</li> <li>• If voltage is low, correct wiring.</li> </ul>
Cooling ability is poor.	<ul style="list-style-type: none"> <li>• Check if the set is placed close to wall.</li> <li>• Check if the set is placed close to stove, gas cooker and direct rays.</li> <li>• Is the ambient temperature high or the room door closed?</li> <li>• Check if put in is hot.</li> <li>• Did you open the door of the set too often or check if the door is closed up?</li> <li>• Check if the Control is set to WARM.</li> </ul>	<ul style="list-style-type: none"> <li>• Place the set with the space of about 10 cm (4 inches).</li> <li>• Place the set apart from these heat appliances.</li> <li>• Make the ambient temperature below.</li> <li>• Put in foods after cooled down.</li> <li>• Don't open the door too often and close it firmly.</li> <li>• Set the control to mid-position.</li> </ul>
Foods in the Refrigerator are frozen.	<ul style="list-style-type: none"> <li>• Is food placed in cooling air outlet?</li> <li>• Check if the Dial is set to COLD.</li> <li>• Is the ambient temperature below 5°C?</li> </ul>	<ul style="list-style-type: none"> <li>• Place foods in high temperature section. (Front Part)</li> <li>• Set the dial to MID.</li> <li>• Set the dial to WARM.</li> </ul>
Dew or ice forms inside the set.	<ul style="list-style-type: none"> <li>• Is liquid food stored?</li> <li>• Check if put in hot.</li> <li>• Did you open the door of the set too often or check if the door is closed.</li> </ul>	<ul style="list-style-type: none"> <li>• Seal up liquid foods with wrap.</li> <li>• Put in foods after cooled down.</li> <li>• Don't open the door too often and close it firmly.</li> </ul>
Dew forms in the Exterior Case.	<ul style="list-style-type: none"> <li>• Check if ambient temperature and humidity of surrounding air are high.</li> <li>• Is there gap in the door gasket?</li> </ul>	<ul style="list-style-type: none"> <li>• Wipe dew with a dry cloth. This occurrence is solved naturally in low temperature and humidity.</li> <li>• Fill up the gap.</li> </ul>
Abnormal noise.	<ul style="list-style-type: none"> <li>• Is the set positioned in a firm and even place?</li> <li>• Are any unnecessary objects set in the back side of the set?</li> <li>• Check if the Drip Tray is not firmly fixed.</li> <li>• Check if the cover of mechanical room in below and front side is taken out.</li> </ul>	<ul style="list-style-type: none"> <li>• Adjust the Adjust Screw, and position in the firm place.</li> <li>• Remove the objects.</li> <li>• Fix it firmly on the original position.</li> <li>• Place the cover at the original position.</li> </ul>
Door does not close well.	<ul style="list-style-type: none"> <li>• Check if the door packing is dirty with filth such as juice.</li> <li>• Is the set positioned in a firm and even place?</li> <li>• Is too much food putted in the set?</li> </ul>	<ul style="list-style-type: none"> <li>• Clean the door packing.</li> <li>• Position in the firm place and level the Adjust Screw.</li> <li>• Keep foods not to reach the door.</li> </ul>
Ice and foods smell unpleasant.	<ul style="list-style-type: none"> <li>• Check if the inside of the set is dirty.</li> <li>• Did you keep fragrant foods without wrapping?</li> <li>• It smells of plastic.</li> </ul>	<ul style="list-style-type: none"> <li>• Clean the inside of the set.</li> <li>• Wrap fragrant foods.</li> <li>• The new products smells of plastic, but it will go away after 1-2 weeks.</li> </ul>

● In addition to the items described left, refer to the followings to solve the complaint.

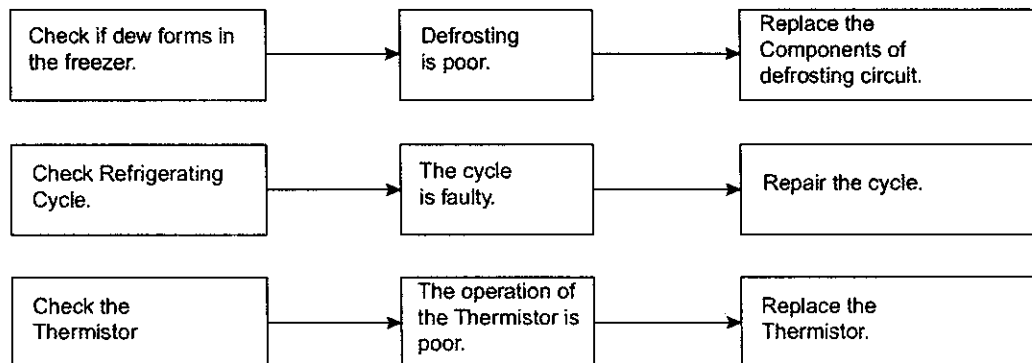

## 6-5 REFRIGERATING CYCLE

### ▼ Troubleshooting Chart

CAUSE		STATE OF THE SET	STATE OF THE EVAPORATOR	TEMPERATURE OF THE COMPRESSOR	REMARKS
LEAKAGE	PARTIAL LEAKAGE	Freezer compartment and Refrigerator don't cool normally.	Low flowing sound of Refrigerant is heard and frost forms in inlet only	A little higher than ambient temperature.	<ul style="list-style-type: none"> <li>Refrigerant level is low due to a leak.</li> <li>Normal cooling is possible when injecting of Refrigerant the regular amount.</li> </ul>
	WHOLE LEAKAGE	Freezer compartment and Refrigerator don't cool normally.	Flowing sound of refrigerant is not heard and frost isn't formed.	Equal to ambient temperature.	<ul style="list-style-type: none"> <li>No discharging of Refrigerant.</li> <li>Normal cooling is possible when injecting of Refrigerant the regular amount.</li> </ul>
CLOGGED BY DUST	PARTIAL CLOG	Freeze compartment and Refrigerator don't cool normally.	Flowing sound of refrigerant is heard and frost forms in inlet only.	A little higher than ambient temperature.	<ul style="list-style-type: none"> <li>Normal discharging of refrigerant.</li> <li>The capillary tube is faulty.</li> </ul>
	WHOLE CLOG	Freezer compartment and Refrigerator don't cool.	Flowing sound of refrigerant is not heard and frost isn't formed.	Equal to ambient temperature.	<ul style="list-style-type: none"> <li>Normal discharging of Refrigerant.</li> </ul>
MOISTURE CLOG		Cooling operation stops periodically.	Flowing sound of refrigerant is not heard and frost melts.	Lower than ambient temperature	<ul style="list-style-type: none"> <li>Cooling operation restarts when heating the inlet of capillary tube.</li> </ul>
DEFECTIVE COMPRESSION	COMP-RESSION	Freezer and Refrigerator don't cool.	Low flowing sound of refrigerant is heard and frost forms in inlet only.	A little higher ambient temperature.	<ul style="list-style-type: none"> <li>Low pressure at high side of compressor due to low refrigerant level.</li> </ul>
	NO COMP-RESSION	No compressing operation.	Flowing sound of refrigerant is not heard and no frost.	Equal to ambient temperature.	<ul style="list-style-type: none"> <li>No pressure of high pressure part in the compressor.</li> </ul>

### ▼ Leakage Detection

- Observe discharging point of refrigerant which may be in the oil discharging part in the compressor and hole of evaporator.

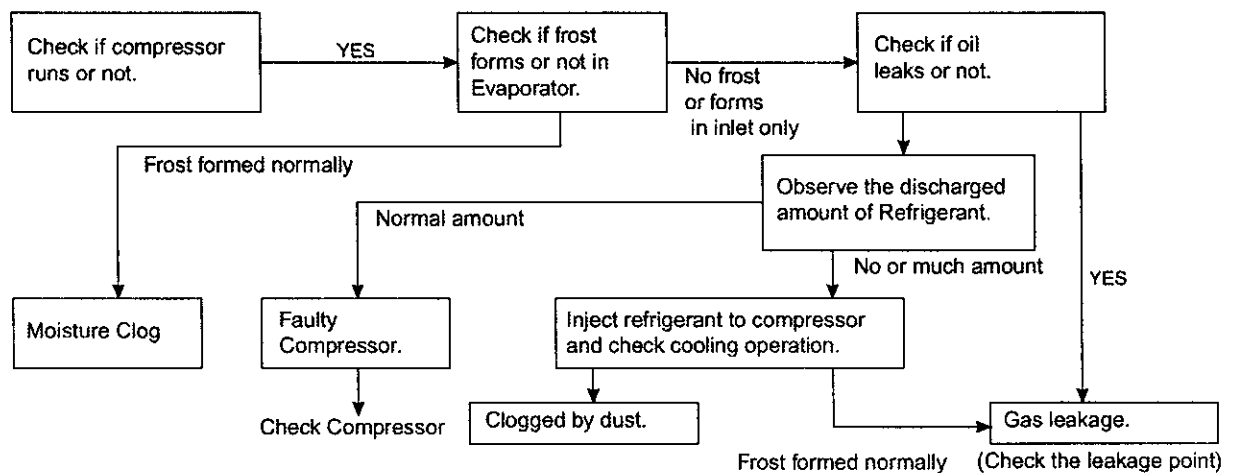

▼ General Control of Refrigerating Cycle

NO.	ITEMS	UNIT	STANDARDS	PURPOSES	REMARKS	
1	Pipe and piping system opening time	Min.	Pipe: within 1 hour. Comp: within 10 minutes. Drier: within 20 minutes.	To protect moisture penetration.	The opening time should be reduced to a half of the standards during rain and rainy seasons (the penetration of water into the pipe is dangerous).	
2	Welding	Nitrogen pressure	Weld under Nitrogen atmosphere. (N <sub>2</sub> pressure: 0.1-0.2 kg/cm <sup>2</sup> )	To protect oxide scale formation.	- Refer to repair note in each part. - R-134a refrigerant is more susceptible to leaks than R-12 and requires more care during welding. - Do not apply force to pipes before and after welding to protect pipe from cracking.	
3	N <sub>2</sub> sealed parts	Confirm N <sub>2</sub> leak	Confirm air leaking sounds when removing rubber cap. Sound: usable No sound: not usable	To protect moisture penetration.	- In case of evaporator parts, if it doesn't make sound when removing rubber cap, blow dry air or N <sub>2</sub> gas for more than 1 min and use the parts.	
4	Refrigeration Cycle	Evacuation time	Min.	More than 40 minutes	To remove moisture.	
		Vacuum degree	Torr	Below 0.03 (ref)		Note: Only applicable to the model equipped with reverse flow protect plate.
		Vacuum	EA	High and low pressure sides are evacuated at the same time for models above 200 l.		Vacuum efficiency can be improved by operating compressor during evacuation.
		Vacuum piping	EA	Use R-134a exclusive manifold.	To protect mixing of mineral and ester oils.	The rubber pipes for R-12 refrigerant shall be melted when they are used for R-134a refrigerant (causes of leak.)
		Pipe coupler	EA	Use R-134a exclusive.	To protect R-12 refrigerant mixing.	
		Outlet (Socket)		R-134a exclusive.	"	
	Plug		R-134a exclusive.	"		
5	Refrigerant weighing	EA	Use R-134a exclusively. Weighing allowance: ±5g Note: Winter: -5g Summer: +5g	Do not mix with R-12 refrigerant.	- Do not weigh the refrigerant at too hot or too cold an area. (77°F[25°C] is adequate.) - Make Copper bombe (Device filling refrigerant) Socket: 2SV Plug: 2PV R-134a Note: Do not burn O-ring (bushing) during welding.	
6	Drier replacement		- Use R-134a exclusively for R-134a refrigerator. - Use R-12 exclusively for R-12 refrigerator. - Replace drier whenever repairing refrigerator cycle piping.	To remove the moisture from pipe inside.		
7	Leak check		- Do not use soapy water for check. It may be sucked into the pipe by vacuum.	Defect refrigerant leak area.	- Check oil leak at refrigerant leak area. Use electronic leak detector if oil leak is not found. - The electronic leak detector is very sensitive to halogen gas in the air. It also can detect R-141b in urethane. Practice many times before using this type of detector.	

# 8. EXPLODED VIEW & REPLACEMENT PARTS LIST

- ▼ The parts of refrigerator and the shape of each part are subject to change in different localities.
- ▼ Capacitors and fuse are optional parts.

**GR-T622, GR-T722**

