

This Owner's Manual is provided and hosted by [Appliance Factory Parts](http://ApplianceFactoryParts.com).

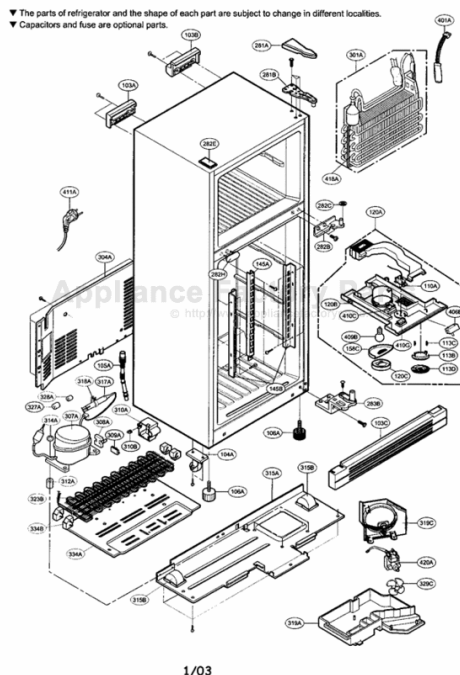

LG LRTPC2031BS Owner's Manual

[Shop genuine replacement parts for LG LRTPC2031BS](#)



[Find Your LG Refrigerator Parts - Select From 834 Models](#)

----- Manual continues below -----

CIRCUIT DIAGRAM

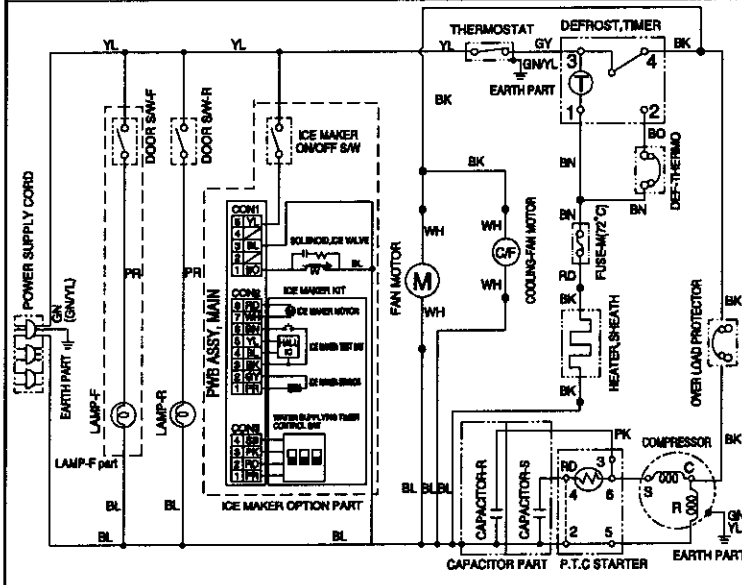

* LAMP-F PART, CAPACITORS, THE PLUG TYPE, EARTH PART AND ICE MAKER OPTION PART ON CIRCUIT DIAGRAM ARE SUBJECT TO CHANGE IN DIFFERENT LOCALITIES.

WH: WHITE BL: BLUE RD: RED GY: GRAY/PURPLE YL: YELLOW BO: BRIGHT ORANGE
 BK: BLACK BN: BROWN PR: PURPLE PK: PINK GN: GREEN

WATER SUPPLYING TIME CONTROL OPTION

▶ CAUTION : Please unplug the power cord from the wall outlet.

| SWITCH NO | | | TIME |
|-----------|-----|-----|----------|
| SW1 | SW2 | SW3 | |
| OFF | OFF | OFF | 10.5 sec |
| ON | OFF | OFF | 9 sec |
| OFF | ON | OFF | 10 sec |
| ON | ON | OFF | 11 sec |
| OFF | OFF | ON | 12 sec |
| ON | OFF | ON | 13 sec |
| OFF | ON | ON | 14 sec |
| ON | ON | ON | 15 sec |

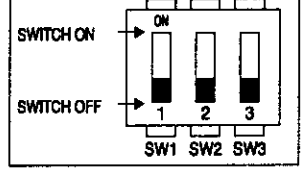

3854JD1046C

2. PARTS IDENTIFICATION

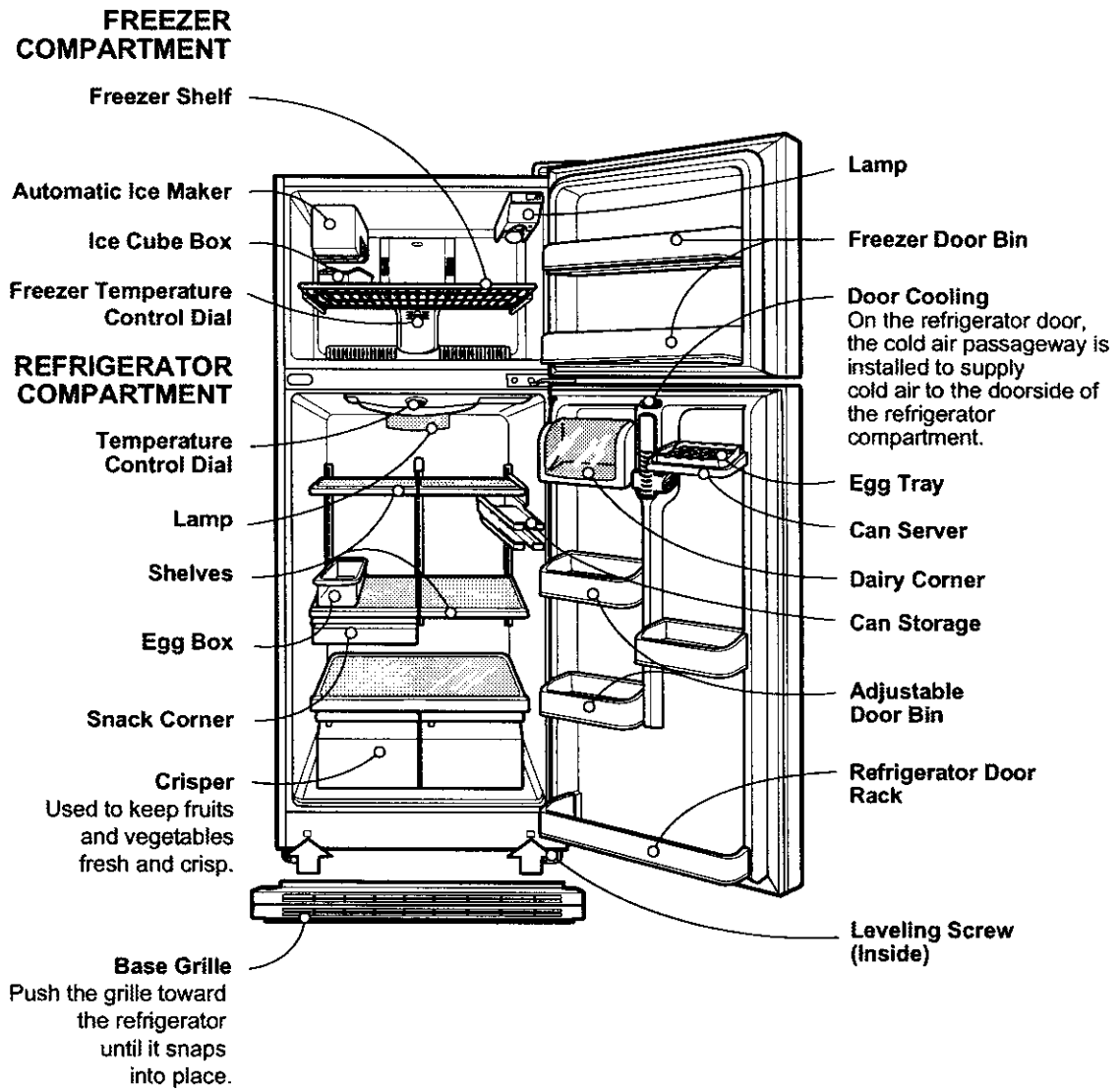

3. DISASSEMBLY

3-1 DOOR

● Freezer Door

1. Remove the hinge cover by pulling it upwards.
2. Loosen hexagonal bolts fixing the upper hinge to the body and lift the freezer door.

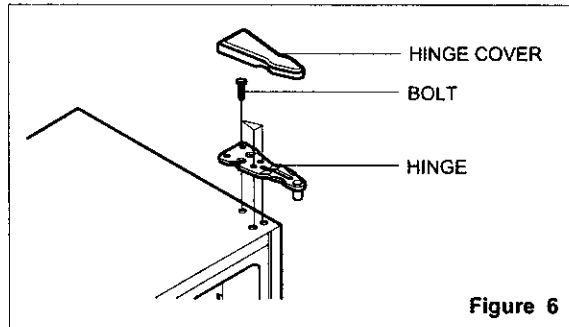

3. Pull out the door gasket to remove from the door foam assembly.

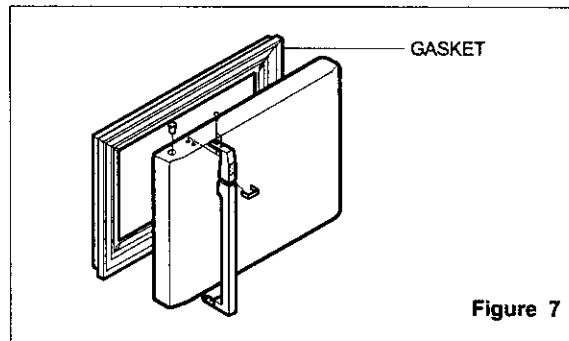

● Refrigerator Door

1. Loosen hexagonal bolts attaching the lower hinge to the body to remove the refrigerator door only.

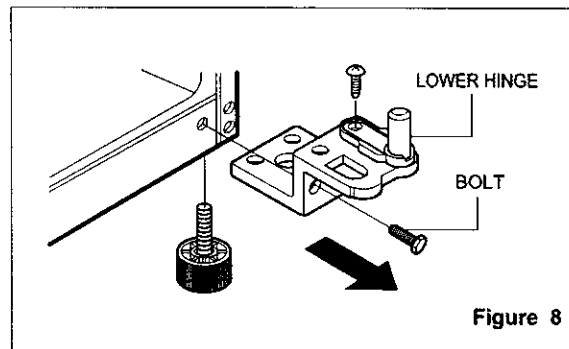

2. Pull out the door gasket to remove from the door foam assembly.

3-2 DOOR SWITCH

1. To remove the door switch, pull it out with a slotted type driver as shown in (figure 9).
2. Disconnect the lead wire from the switch.

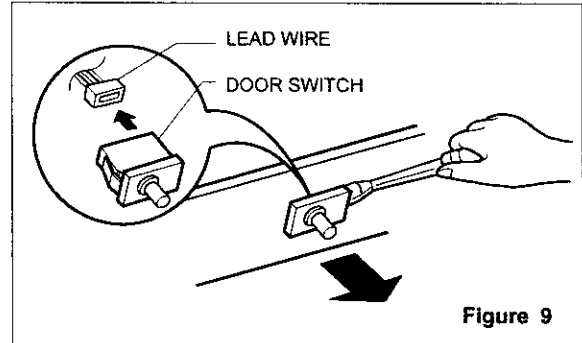

3-3 THERMOSTAT

1. Remove Control Box-R by loosening 2 screws attached to ceiling of Refrigerator compartment (Figure 10)
2. Separate the thermostat and dial knob F.
3. Remove the thermostat by disconnecting the lead wire.

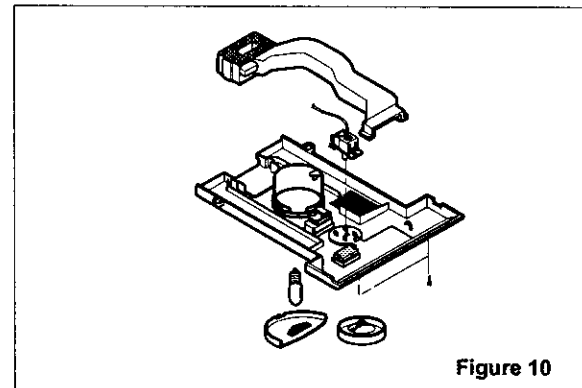

3-4 FAN AND FAN MOTOR

1. Remove the freezer shelf. (If your refrigerator have an Ice Maker, disassemble the Ice maker first)
2. Remove the grille by pulling it out and by loosening a screw.
3. Remove the Fan Motor assembly by loosening 4 screws and disassemble the shroud.
4. Pull out the fan and separate the Fan Motor and Bracket.

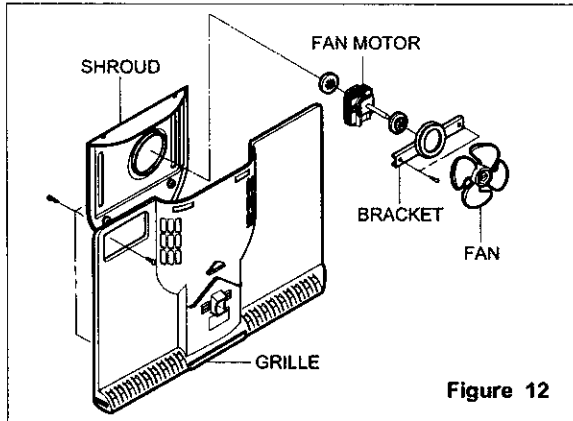

Figure 12

3-5 DEFROST CONTROL ASSEMBLY

Defrost control assembly consists of Defrost Thermostat and FUSE-M.

Defrost Thermostat functions to defrost automatically and it is attached to metal side of the Evaporator and senses Temp.

Fuse-M is a safety device for preventing over-heating of the Heater when defrosting.

At the temperature of 77°C, it stops the emission of heat from the Heater.

1. Pull out the grille assembly.
2. Separate the connector connected with the Defrost Control assembly and replace the Defrost Control assembly after cutting the Tie Wrap. (Figure 14)

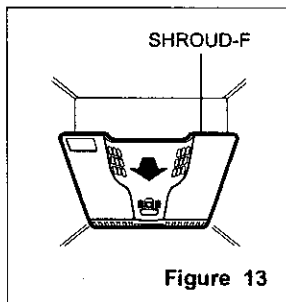

Figure 13

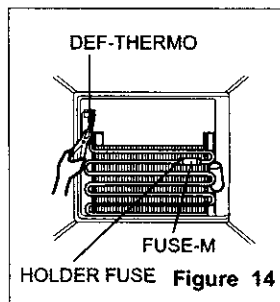

Figure 14

3-6 LAMP

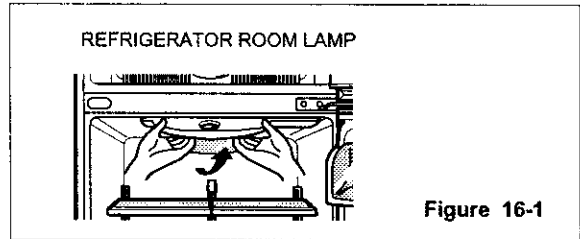

Figure 16-1

3-6-1 Refrigerator room lamp

1. Unplug the power cord from the outlet.
2. Remove refrigerator shelves.
3. Release the hooks on both ends of the lamp shield and pull the shield downward to remove it.
4. Turn the lamp counterclockwise.
5. Assemble in reverse order of disassembly. Replacement bulb must be the same specification as original. (Max 40 W)

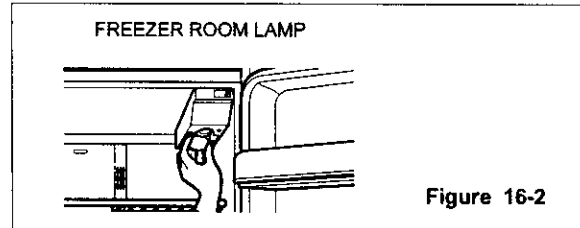

Figure 16-2

3-6-2 Freezer room lamp

1. Unplug refrigerator or disconnect power.
2. Reach behind light shield to remove bulb.
3. Replace bulb with a 25-watt appliance bulb.
4. Plug in refrigerator or reconnect power.

3-7 CONTROL BOX-R

1. First, remove all shelves in the refrigerator and Control Box-R by loosening 2 screws.

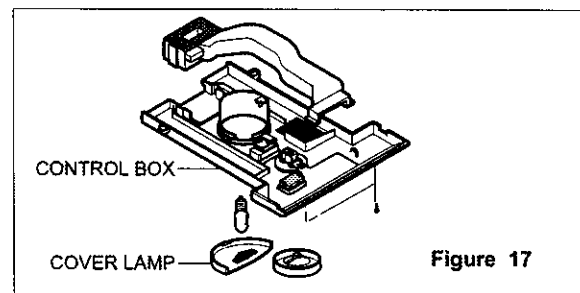

Figure 17

2. Remove the Control Box-R by pulling it downward.
3. Disconnect the lead wire on the right position and separate timer, thermostat, Lamp socket, etc.

4. ADJUSTMENT

4-1 COMPRESSOR

4-1-1 Role

The compressor intakes low temperature and low pressure gas evaporated from evaporator of the refrigerator, and condenses this gas to high temperature and high pressure gas, and then plays delivering role to condenser.

4-1-2 Composition

The compressor includes overload protection. The PTC starter and OLP (overload protector) are outside the compressor. Since the compressor is manufactured to tolerances of 1 micron, and is sealed in a dust - and moisture - free environment, use extreme caution when repairing it.

4-1-3 Note for Usage

- (1) Be careful not to allow over-voltage and over-current.
- (2) No Strike
If applying forcible power or strike (dropping or careless handling), poor operation and noise may occur.
- (3) Use proper electric components appropriate to the Compressor.
- (4) Note to Keep Compressor.
If Compressor gets wet in the rain and rust in the pin of Hermetic Terminal, the result may be poor operation and poor contact may cause.
- (5) Be careful that dust, humidity, and welding flux don't contaminate the compressor inside when replacing the Compressor. Dust, humidity, and flux due to welding which contaminates the cylinder may cause lockage and noise.

4-2 PTC-STARTER

4-2-1 Composition of PTC-Starter

- (1) PTC (Positive Temperature Coefficient) is a no-contact semiconductor starting device which uses ceramic material consisting of $BaTiO_3$.
- (2) The higher the temperature is, the higher the resistance value. These features are used as starting device for the Motor.

4-2-2 Role of PTC-Starter

- (1) PTC is attached to Hermetic Compressor used for Refrigerator, Show Case, and starting Motor.
- (2) Compressor for household refrigerator applies to single-phase induction Motor.
For normal operation of the single-phase induction motor, in the starting operation flows in both main coil and sub-coil. After the starting is over, the current in subcoil is cut off. The proper features of PTC play all the above roles. So, PTC is used as a motor starting device.

4-2-3 PTC-Applied Circuit Diagram

● According to Starting Method for the Motor

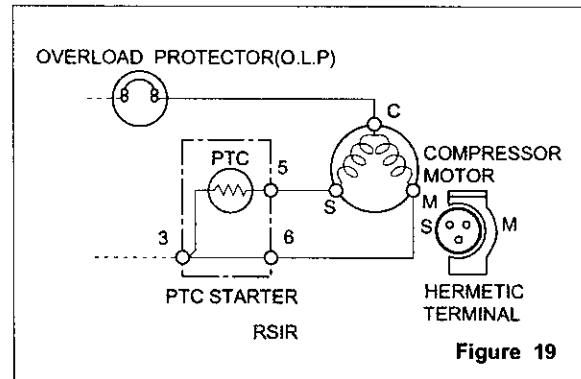

Figure 19

4-2-4 Motor Restarting and PTC Cooling

- (1) For restarting after power off during normal Compressor Motor operation, plug the power cord after 5 min. for pressure balance of Refrigerating Cycle and PTC cooling.
- (2) During normal operation of the Compressor Motor, PTC elements generate heat continuously. Therefore, if PTC isn't cooled for a while after the power has been shut off, the motor will not restart.

4-2-5 Relation of PTC-Starter and OLP

- (1) If the power is off during operation of Compressor and the power is on before the PTC is cooled, (instant shut-off within 2 min. or unplugging and reconnecting), the PTC isn't cooled and a resistance value grows. As a result, current can't flow to the sub-coil, the Motor can't operate, and the OLP operates by flowing over current in only in the main-coil.
- (2) While the OLP repeats on and off operation about 3-5 times, PTC is cooled and Compressor Motor performs normal operation.
If OLP doesn't operate when PTC is not cooled, Compressor Motor is worn away and causes circuit-short and fire. Therefore, always use a properly attached OLP.

4-2-6 Note to Use PTC-Starter

- (1) Be careful not to allow over-voltage and over-current.
- (2) Do not strike
Don't apply a forcible power or strike.
- (3) Keep apart from any liquid.
If liquid, such as oil or water away enters the PTC, PTC materials may fail due to insulation breakdown of the material itself.
- (4) Don't change PTC at your convenience.
Don't disassemble PTC and case. If the exterior to the PTC-starter is damaged, resistance value is altered and it may cause poor starting of the compressor motor may cause.
- (5) Use a properly attached PTC.

4-3 OLP (OVERLOAD PROTECTOR)

4-3-1 Definition of OLP

- (1) OLP (OVERLOAD PROTECTOR) is attached to the Compressor and protects the Motor by cutting the current to the Motor if the temperature rises and activates the bimetal spring in the OLP.
- (2) When over-voltage flows to Compressor motor, the Bimetal works by heating the heater inside the OLP, and the OLP protects Motor by cutting off current which flows to the Compressor Motor.

4-3-2 Role of the OLP

- (1) The OLP is attached to the Hermetic Compressor used for the Refrigerator and prevents the Motor Coil from being started in the Compressor.
 - (2) Do not turn the Adjust Screw of the OLP in any way for normal operation of the OLP.
- (Composition and connection diagram of OLP)

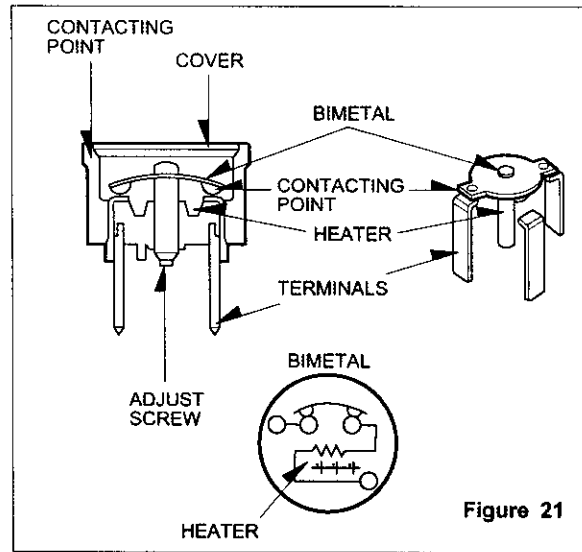
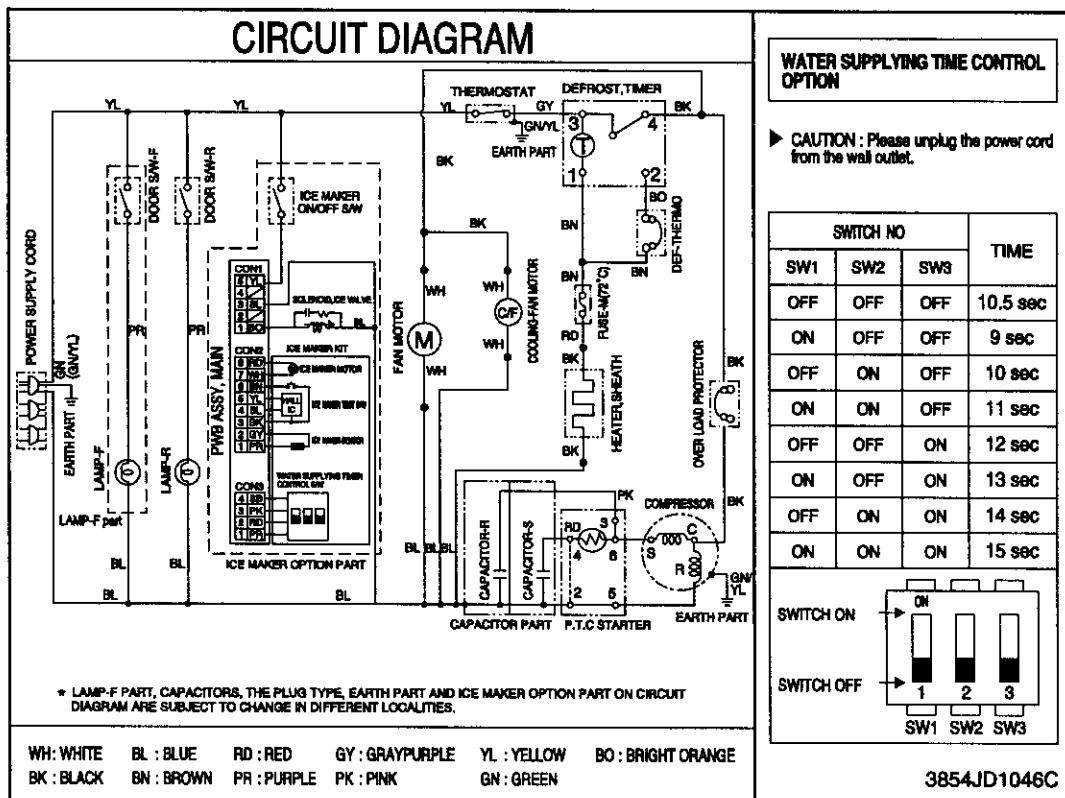

Figure 21

5. CIRCUIT DIAGRAM



6. TROUBLESHOOTING

6-1 COMPRESSOR AND ELECTRIC COMPONENTS

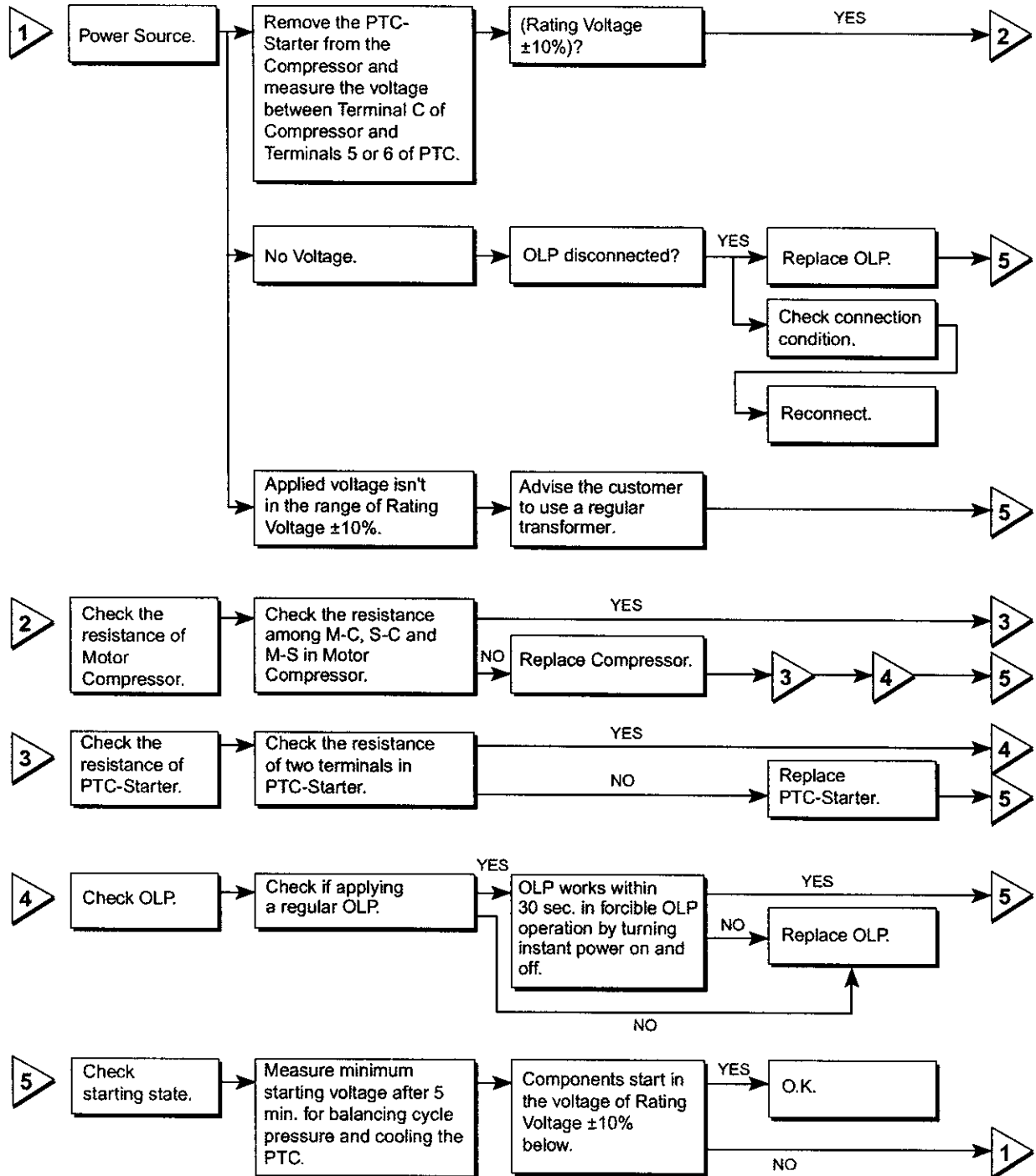

6-2 PTC AND OLP

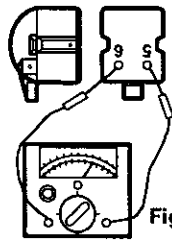
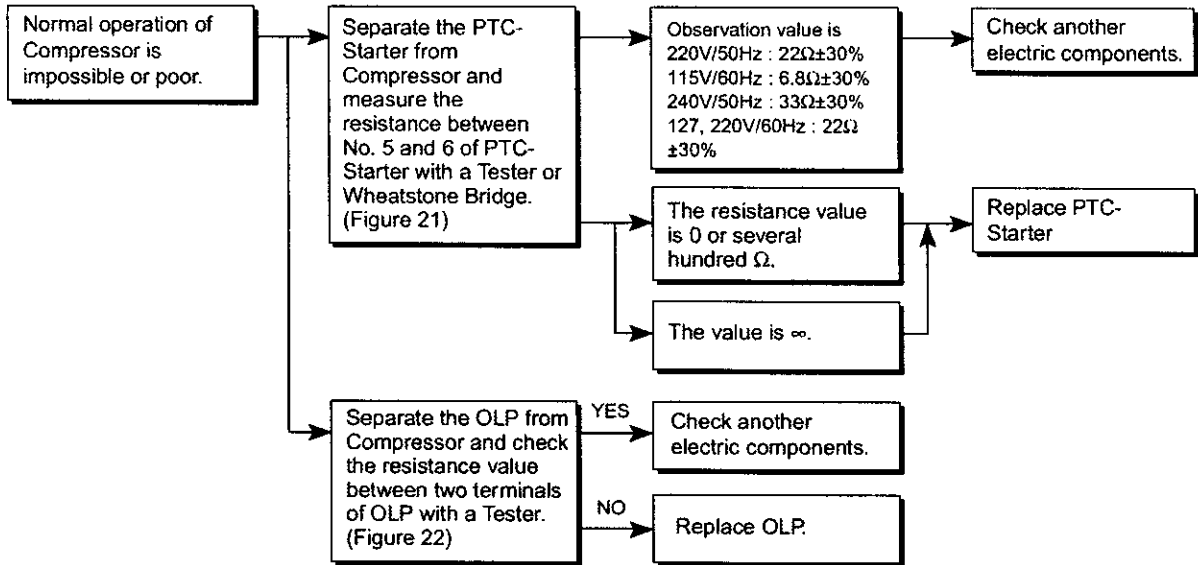

Figure 21

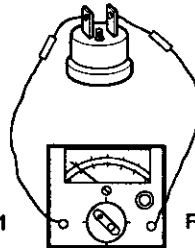

Figure 22

6-3 DEFROST TIMER

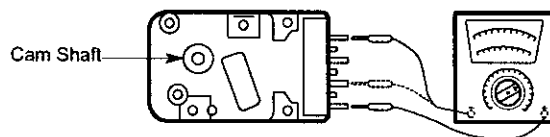
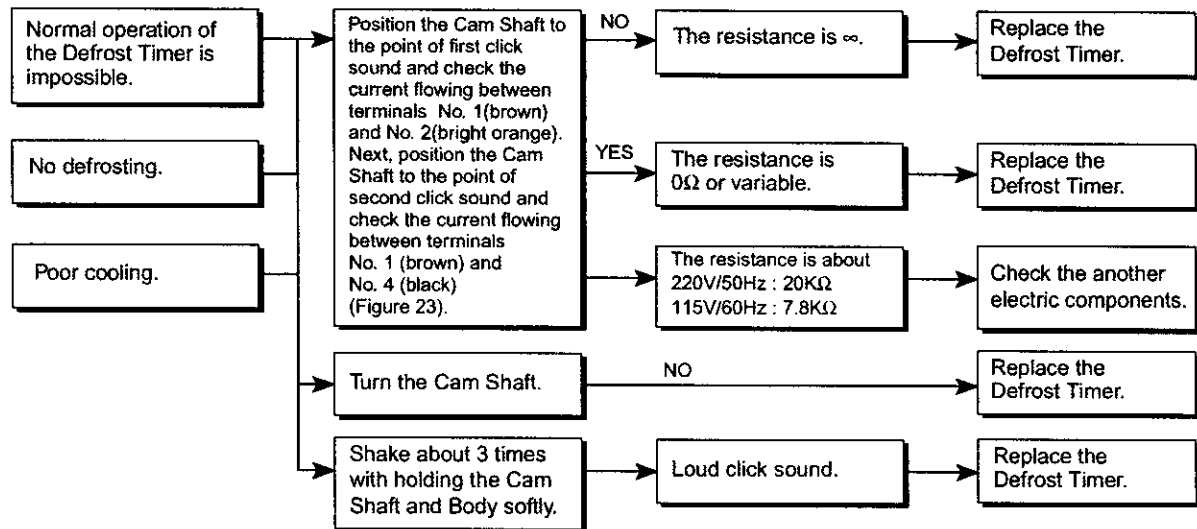
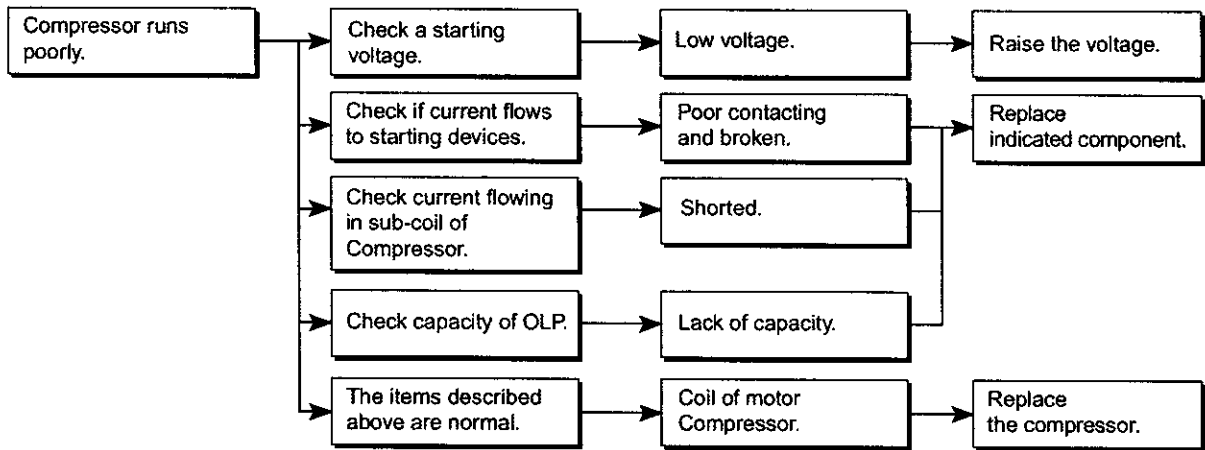
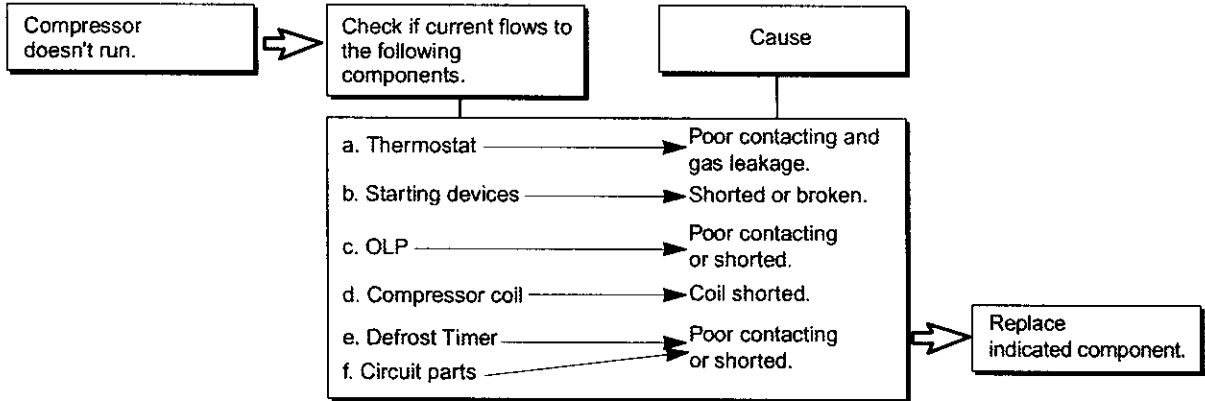

Figure 23

6-4 OTHER ELECTRIC COMPONENTS

▼ Cooling is impossible



▼ Cooling ability is poor

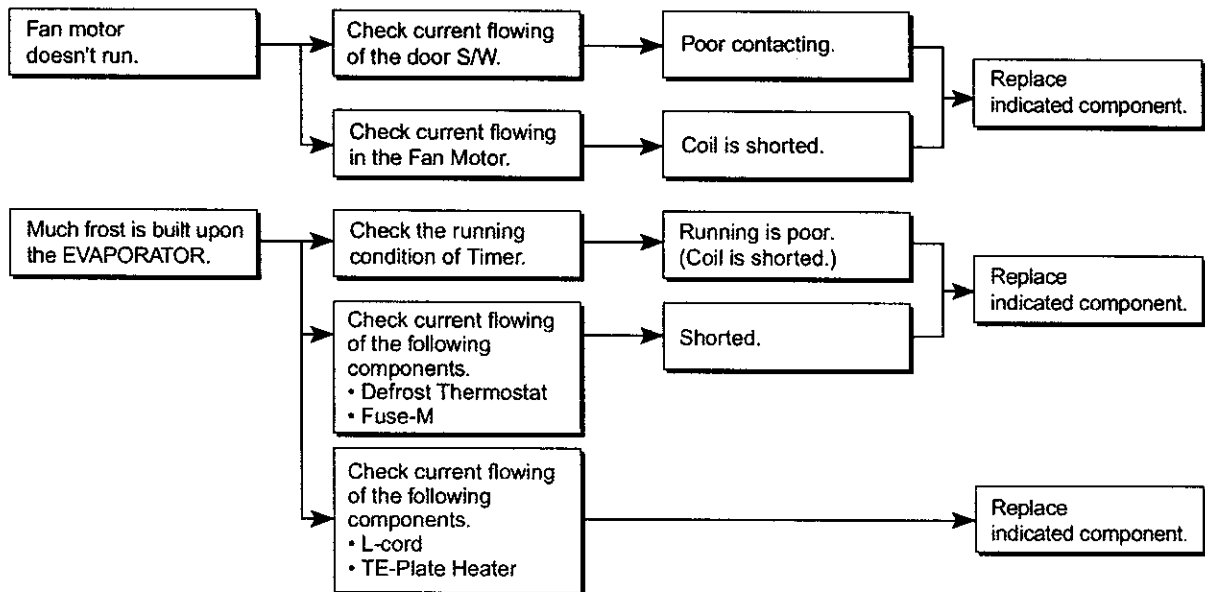

6-4 SERVICE DIAGNOSIS CHART

| COMPLAINT | POINTS TO BE CHECKED | REMEDY |
|---------------------------------------|---|--|
| Cooling is impossible. | <ul style="list-style-type: none"> Is the power cord unplugged from the outlet? Check if the power S/W is set to OFF. Check if the fuse of power S/W is shorted. Measure the voltage of power outlet. | <ul style="list-style-type: none"> Plug to the outlet. Set the switch to ON. Replace fuse. If voltage is low, correct wiring. |
| Cooling ability is poor. | <ul style="list-style-type: none"> Check if the set is placed close to wall. Check if the set is placed close to stove, gas cooker and direct rays. Is the ambient temperature high or the room door closed? Check if put in is hot. Did you open the door of the set too often or check if the door is closed up? Check if the Control is set to WARM. | <ul style="list-style-type: none"> Place the set with the space of about 10 cm (4 inches). Place the set apart from these heat appliances. Make the ambient temperature below. Put in foods after cooled down. Don't open the door too often and close it firmly. Set the control to mid-position. |
| Foods in the Refrigerator are frozen. | <ul style="list-style-type: none"> Is food placed in cooling air outlet? Check if the Dial is set to COLD. Is the ambient temperature below 5°C? | <ul style="list-style-type: none"> Place foods in high temperature section. (Front Part) Set the dial to MID. Set the dial to WARM. |
| Dew or ice forms inside the set. | <ul style="list-style-type: none"> Is liquid food stored? Check if put in hot. Did you open the door of the set too often or check if the door is closed. | <ul style="list-style-type: none"> Seal up liquid foods with wrap. Put in foods after cooled down. Don't open the door too often and close it firmly. |
| Dew forms in the Exterior Case. | <ul style="list-style-type: none"> Check if ambient temperature and humidity of surrounding air are high. Is there gap in the door gasket? | <ul style="list-style-type: none"> Wipe dew with a dry cloth. This occurrence is solved naturally in low temperature and humidity. Fill up the gap. |
| Abnormal noise. | <ul style="list-style-type: none"> Is the set positioned in a firm and even place? Are any unnecessary objects set in the back side of the set? Check if the Drip Tray is not firmly fixed. Check if the cover of mechanical room in below and front side is taken out. | <ul style="list-style-type: none"> Adjust the Adjust Screw, and position in the firm place. Remove the objects. Fix it firmly on the original position. Place the cover at the original position. |
| Door does not close well. | <ul style="list-style-type: none"> Check if the door packing is dirty with filth such as juice. Is the set positioned in a firm and even place? Is too much food putted in the set? | <ul style="list-style-type: none"> Clean the door packing. Position in the firm place and level the Adjust Screw. Keep foods not to reach the door. |
| Ice and foods smell unpleasant. | <ul style="list-style-type: none"> Check if the inside of the set is dirty. Did you keep fragrant foods without wrapping? It smells of plastic. | <ul style="list-style-type: none"> Clean the inside of the set. Wrap fragrant foods. The new products smells of plastic, but it will go away after 1-2 weeks. |

• In addition to the items described left, refer to the followings to solve the complaint.

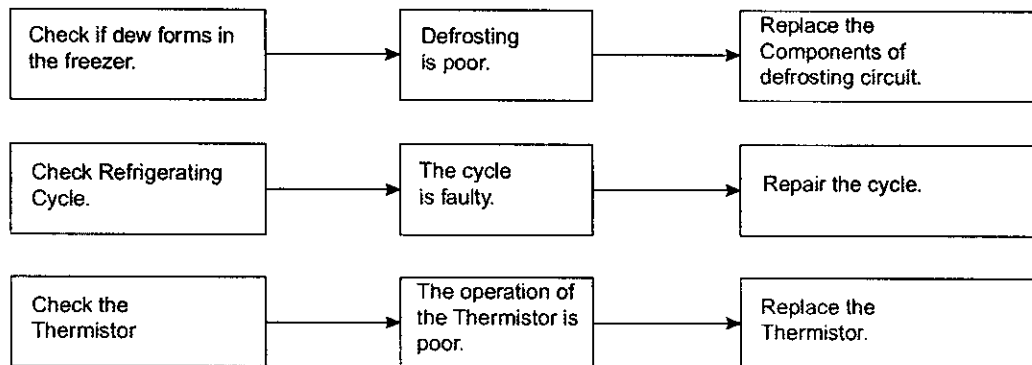

6-5 REFRIGERATING CYCLE

▼ Troubleshooting Chart

| CAUSE | | STATE OF THE SET | STATE OF THE EVAPORATOR | TEMPERATURE OF THE COMPRESSOR | REMARKS |
|-----------------------|-----------------|---|--|---|---|
| LEAKAGE | PARTIAL LEAKAGE | Freezer compartment and Refrigerator don't cool normally. | Low flowing sound of Refrigerant is heard and frost forms in inlet only | A little higher than ambient temperature. | <ul style="list-style-type: none"> Refrigerant level is low due to a leak. Normal cooling is possible when injecting of Refrigerant the regular amount. |
| | WHOLE LEAKAGE | Freezer compartment and Refrigerator don't cool normally. | Flowing sound of refrigerant is not heard and frost isn't formed. | Equal to ambient temperature. | <ul style="list-style-type: none"> No discharging of Refrigerant. Normal cooling is possible when injecting of Refrigerant the regular amount. |
| CLOGGED BY DUST | PARTIAL CLOG | Freeze compartment and Refrigerator don't cool normally. | Flowing sound of refrigerant is heard and frost forms in inlet only. | A little higher than ambient temperature. | <ul style="list-style-type: none"> Normal discharging of refrigerant. The capillary tube is faulty. |
| | WHOLE CLOG | Freezer compartment and Refrigerator don't cool. | Flowing sound of refrigerant is not heard and frost isn't formed. | Equal to ambient temperature. | <ul style="list-style-type: none"> Normal discharging of Refrigerant. |
| MOISTURE CLOG | | Cooling operation stops periodically. | Flowing sound of refrigerant is not heard and frost melts. | Lower than ambient temperature | <ul style="list-style-type: none"> Cooling operation restarts when heating the inlet of capillary tube. |
| DEFECTIVE COMPRESSION | COMP-RESSION | Freezer and Refrigerator don't cool. | Low flowing sound of refrigerant is heard and frost forms in inlet only. | A little higher ambient temperature. | <ul style="list-style-type: none"> Low pressure at high side of compressor due to low refrigerant level. |
| | NO COMP-RESSION | No compressing operation. | Flowing sound of refrigerant is not heard and no frost. | Equal to ambient temperature. | <ul style="list-style-type: none"> No pressure of high pressure part in the compressor. |

▼ Leakage Detection

- Observe discharging point of refrigerant which may be in the oil discharging part in the compressor and hole of evaporator.

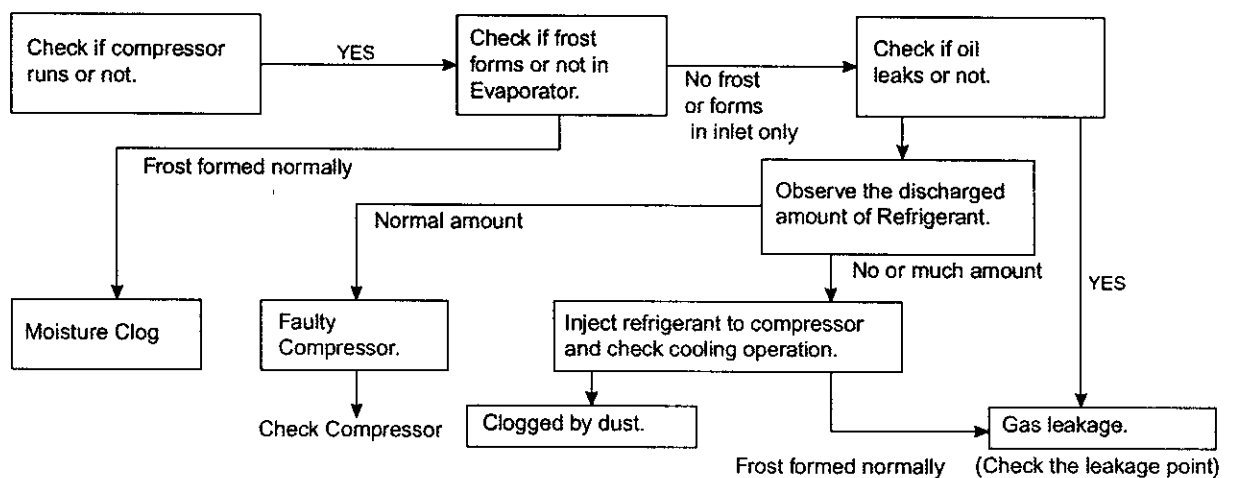

▼ General Control of Refrigerating Cycle

| NO. | ITEMS | UNIT | STANDARDS | PURPOSES | REMARKS | |
|-----|-------------------------------------|-----------------------------|---|--|---|---|
| 1 | Pipe and piping system opening time | Min. | Pipe: within 1 hour. Comp: within 10 minutes. Drier: within 20 minutes. | To protect moisture penetration. | The opening time should be reduced to a half of the standards during rain and rainy seasons (the penetration of water into the pipe is dangerous). | |
| 2 | Welding | Nitrogen pressure | Weld under Nitrogen atmosphere. (N ₂ pressure: 0.1~0.2 kg/cm ²) | To protect oxide scale formation. | - Refer to repair note in each part. - R-134a refrigerant is more susceptible to leaks than R-12 and requires more care during welding. - Do not apply force to pipes before and after welding to protect pipe from cracking. | |
| 3 | N ₂ sealed parts | Confirm N ₂ leak | Confirm air leaking sounds when removing rubber cap. Sound: usable No sound: not usable | To protect moisture penetration. | - In case of evaporator parts, if it doesn't make sound when removing rubber cap, blow dry air or N ₂ gas for more than 1 min and use the parts. | |
| 4 | Refrigeration Cycle | Evacuation time | Min. | More than 40 minutes | To remove moisture. | |
| | | Vacuum degree | Torr | Below 0.03 (ref) | | Note: Only applicable to the model equipped with reverse flow protect plate. |
| | | Vacuum | EA | High and low pressure sides are evacuated at the same time for models above 200 l. | | Vacuum efficiency can be improved by operating compressor during evacuation. |
| | | Vacuum piping | EA | Use R-134a exclusive manifold. | To protect mixing of mineral and ester oils. | The rubber pipes for R-12 refrigerant shall be melted when they are used for R-134a refrigerant (causes of leak.) |
| | | Pipe coupler | EA | Use R-134a exclusive. | To protect R-12 refrigerant mixing. | |
| | | Outlet (Socket) | | R-134a exclusive. | " | |
| | Plug | | R-134a exclusive. | " | | |
| 5 | Refrigerant weighing | EA | Use R-134a exclusively. Weighing allowance: ±5g Note: Winter: -5g Summer: +5g | Do not mix with R-12 refrigerant. | - Do not weigh the refrigerant at too hot or too cold an area. (77°F[25°C] is adequate.) - Make Copper bombe (Device filling refrigerant) Socket: 2SV Plug: 2PV R-134a Note: Do not burn O-ring (bushing) during welding. | |
| 6 | Drier replacement | | - Use R-134a exclusively for R-134a refrigerator. - Use R-12 exclusively for R-12 refrigerator. - Replace drier whenever repairing refrigerator cycle piping. | To remove the moisture from pipe inside. | | |
| 7 | Leak check | | - Do not use soapy water for check. It may be sucked into the pipe by vacuum. | Defect refrigerant leak area. | - Check oil leak at refrigerant leak area. Use electronic leak detector if oil leak is not found. - The electronic leak detector is very sensitive to halogen gas in the air. It also can detect R-141b in urethane. Practice many times before using this type of detector. | |

7. OPERATION PRINCIPLE AND REPAIR METHOD OF ICE MAKER

This manual describes function of models adhering Ice Maker.

7-1 OPERATION PRINCIPLE

7-1-1 Operation principle of Ice Maker

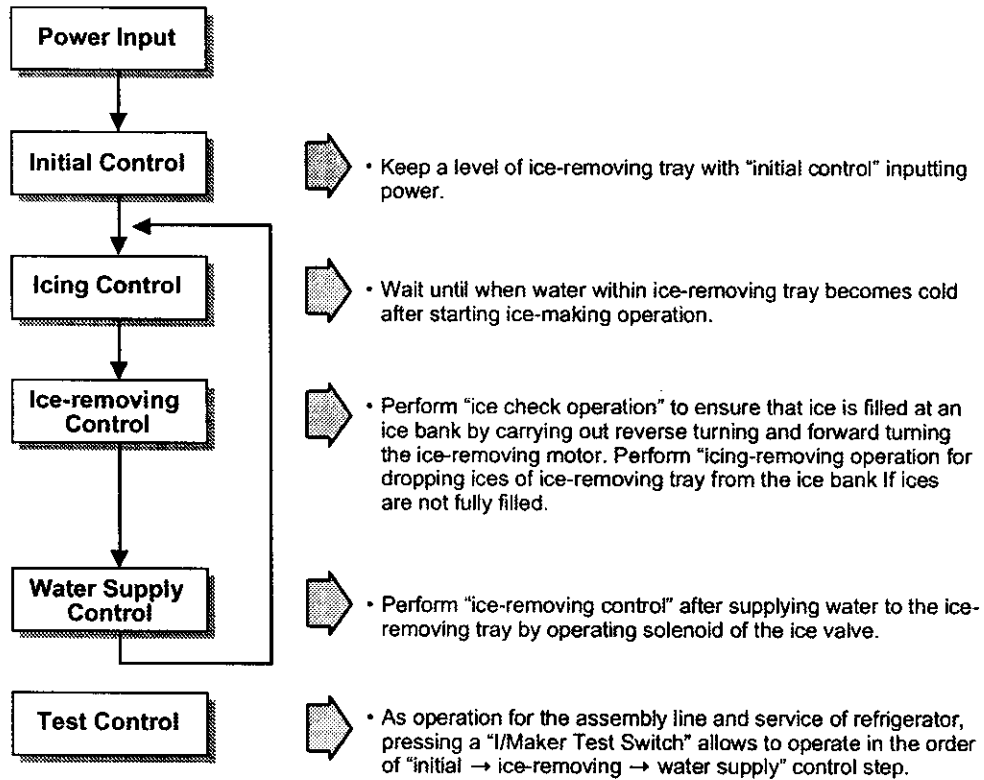

1. Turning the ice-making stop switch off stops ice-making function of the ice-maker and thus no ice is made .
2. Ice-making function stops at the time of selecting ice-making function and release of the ice-making function allows to perform the initial control function again.

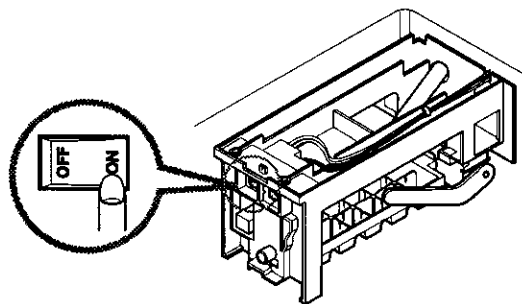

* Make sure the switch on the ice maker assy is turned "on".

7-2 Function of Ice maker

7-2-1 Initial control function

1. The level of the ice-removing tray (ice-removing container) after completing the MICOM initialization in the initial POWER ON, returning to electricity failure and turning-off of ice-making stop switches. Namely, detection lever operates up and down.
2. The level of ice-removing container is detected with high / low output signal of hall sensor.
In another words, operation is performed in order to keep a level by operating ice-removing motor so that high or low voltage could be applied in the MICOM PIN.
3. No signal change of hall sensors until a minute after operating the ice-removing motor should be considered as failure. In this case, stop the automatic ice-remover and then reset the ice-maker initialization if considered as normal after performing continuous check in a cycle of an hour.
4. Keeping of the ice-removing tray (ice-removing container) should be considered initial control is completed.

7-2-2 Water supply control function

1. Supply water into the ice-removing tray by operating the ice solenoid placed at the machine room of refrigerator using the time check function if considered as the level is kept after performing a horizontal operation of the ice-making tray after the ice-removing control (normal ice-removing control, ice-removing control of test function) is completed.
2. The quantity of water supply is determined by supplying water for a constant using the dip switch.

<Water Supply Quantity Table>

| SWITCH NO | | | | TIME | Remarks |
|-----------|-----|-----|--|----------|---|
| SW1 | SW2 | SW3 | | | |
| OFF | OFF | OFF | | 10.5 sec | The quantity of water supply may differ depending on the setting status of the dip switch or on water pressure as water supply method is of a pattern of direct connection to water cock. |
| ON | OFF | OFF | | 9 sec | |
| OFF | ON | OFF | | 10 sec | |
| ON | ON | OFF | | 11 sec | |
| OFF | OFF | ON | | 12 sec | |
| ON | OFF | ON | | 13 sec | |
| OFF | ON | ON | | 14 sec | |
| ON | ON | ON | | 15 sec | |

3. The change of the quantity of water supply setting may be done according to the changed time even after changing it without powering off. In the change of dip switch during water supply, it is done according to the water supply time previously established and then done according to the additionally changed time from the next water supply.

Water supply control switch

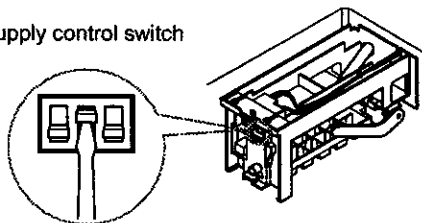

* Adjust the water supply control switch to adjust the amount of water being supplied.

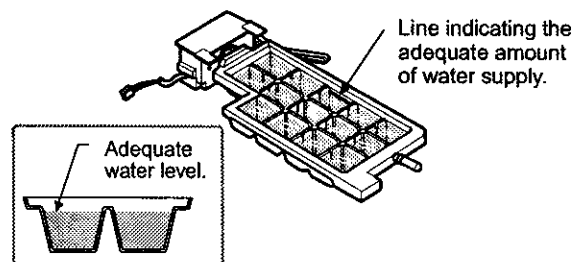

* Make sure it is adjusted to meet the line indicating the adequate amount of water supply.

7-2-3 Ice-making control function

1. Ice-making control is related with when considered as water within ice-making tray (ice container) turns into ice completely after completing water supply operation and performs ice-making completion operation by detecting temperature of ice-making tray. (ice-making sensor is mounted on the bottom of the ice-making tray).
2. Ice-making control begins after completing water supply control or initial control.
3. It is considered that ice-making is completed if temperature of ice-making sensor arrives at -6°C after 60 minutes pass from the time water is supplied to the ice-making tray.
4. It is considered that ice-making is completed if temperature of ice-making sensor arrives at below -7°C after 10 minutes pass at the above status.

7-2-4 Ice-removing control function

1. Ice-removing control means operation to separate ice within ice-making tray (ice-making container) after ice-making is completed.
2. Step to check ices stored at the ice bank (container for storing ice) are fully filled. It is considered as they are fully filled if signals of the hall sensor are at the On status ("high") before 3.6seconds after rotating positively the ice-making motor. In this case, the ice-making motor remains at the waiting status without performing ice-removing function. Perform ice-detecting operation after rotating positively the ice-making motor in the cycle of an hour if the full ice status is detected. Perform water supply control function after completing ice-removing function in the short of ices stored. Reversely rotating the ice-removing motor in the storage of full ices and then let the motor stop at the position of the ice-making or waiting status.
3. Ice-removing control performs ice-removing operation immediately if ices stored at the ice bank (container for storing ice) are not fully filled (the hall sensor are at the Off status ("low") within 3.6seconds after rotating positively the ice-making motor). In this case, it positively rotates (CW) the ice-removing motor and keeps the ice-making tray at the maximum distortion status and makes ices be separated from the ice-making tray. In this case, ice-detecting lever automatically operates lifting operation with ice-removing operation.
4. Ice-removing control positively rotates (CW) the ice-removing motor and stops it for a second as it considers as maximum distortion point (ice-detecting axle = 160°) if the sensor signal changes from the Off status ("low") to the On status ("high") after 3.6 seconds pass.
5. Ice-removing control positively rotates (CW) the ice-removing motor at the cycle of an hour if problems in ice-making motor or hall sensor are found and performs initial operation or operates initialization of product if normal.
6. Ice-removing control stops for a second at the maximum distortion status of the ice-removing tray (container for storing ice).
7. Step that the ice-removing tray stops for a second and then returns to the level. It returns to the level status returns to the ice-removing tray by reversely rotating the ice-making motor.
8. The cycle of "water supply → ice-making → ice-removing → returning to the level" if becoming the level status.

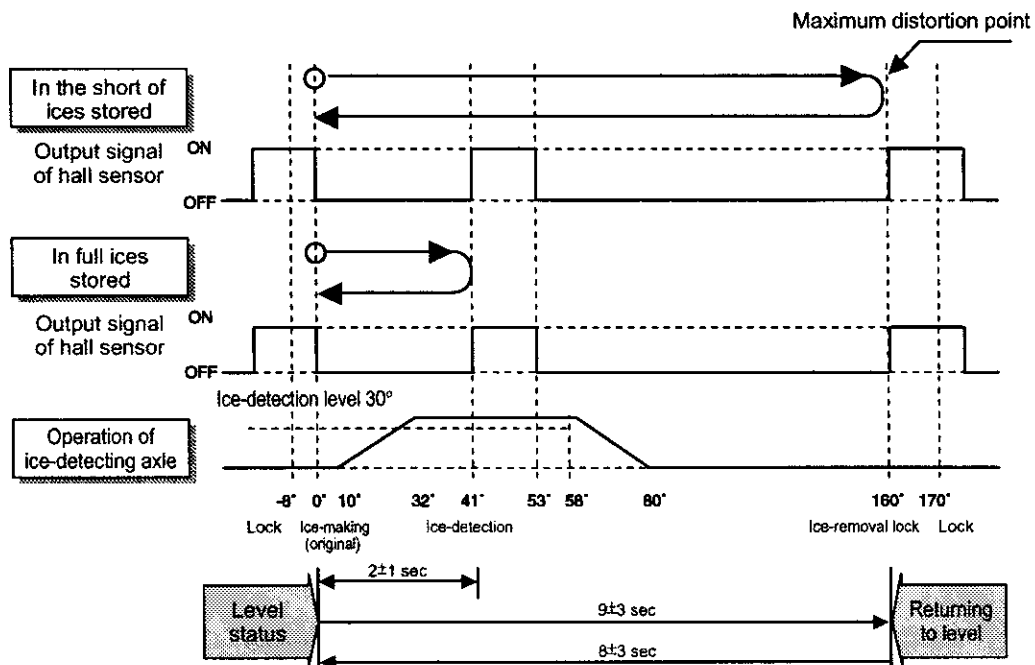

<Timing chart for ice-removal>

7-2-5 Test Function

1. Function used compulsory operation for the purpose of performing operation test, service and cleaning. This test function is performed if pressing the test switch mounted on the automatic ice-maker itself for 0.5 second or more.
2. The test button operates when the test function is not input but at the level status. It does not perform ice-removal control and water supply control if ices are full during operation of test function
3. Pressing the test button for more than 0.5 seconds at the level the status immediately performs ice-removing operation irrespective of the ice generation conditions of the ice-making tray.
Caution shall be exercised as water may overflow if operating the test function at the water status that ice-making is not done. A cycle of water supply is performed at the level adjusting operation after ice-removing operation.
Therefore, the test button allows to check problems in ice-removing operation, level operation and water supply.
4. The test function operates in the normal cycle of ice-making → ice-removal → returning to the level → water supply if water supply is completed.

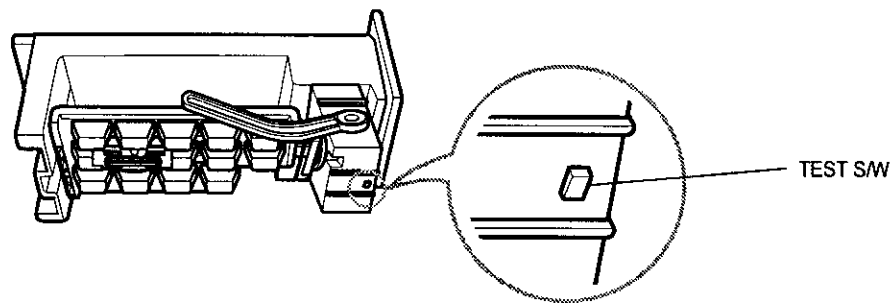

* To check on the amount of water being supplied, press the Test button. (Hold for 0.5 seconds)

7-3 Failure diagnosis method of ice maker

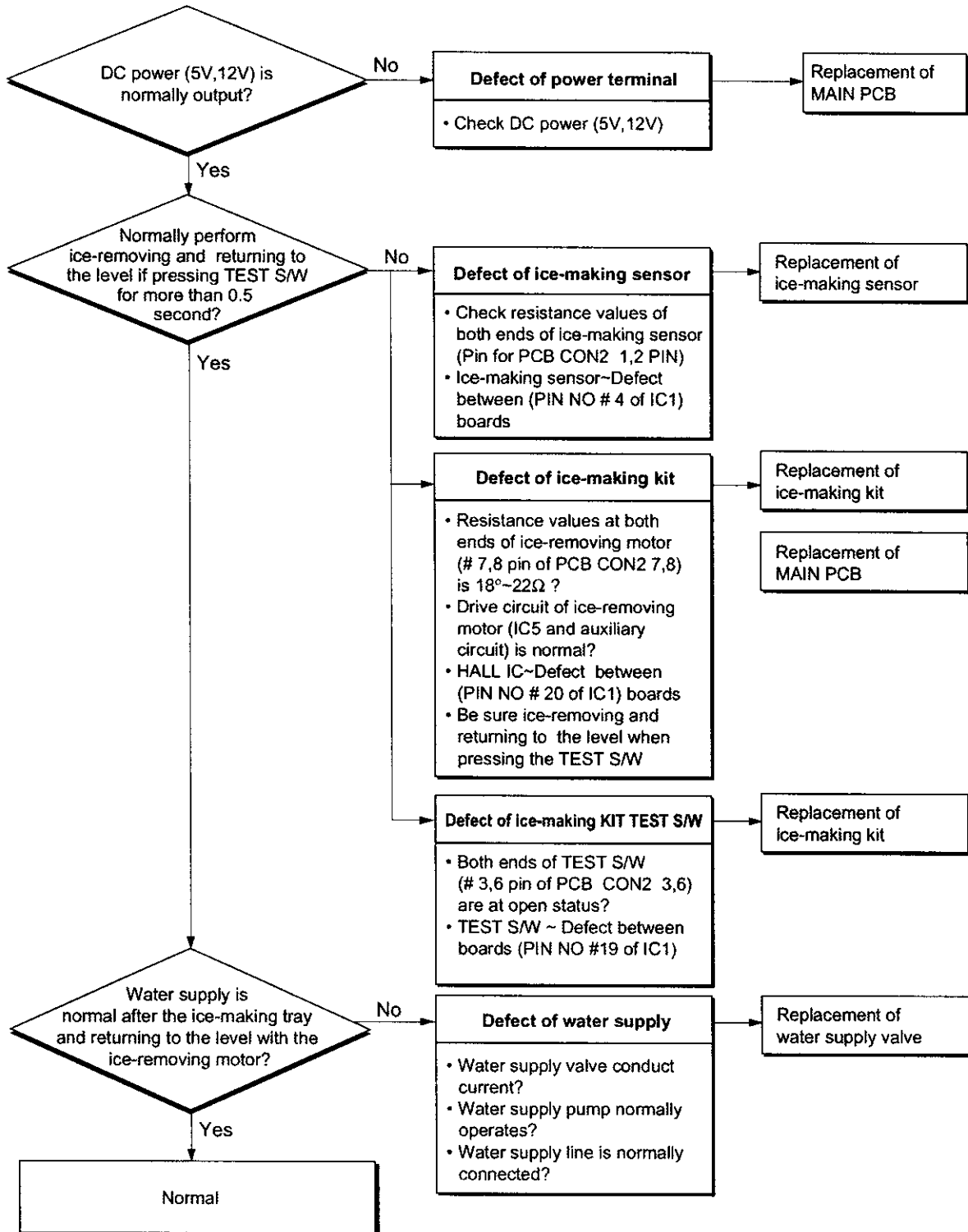

7-4 Explanation of ice maker circuits

7-4-1 Power circuit

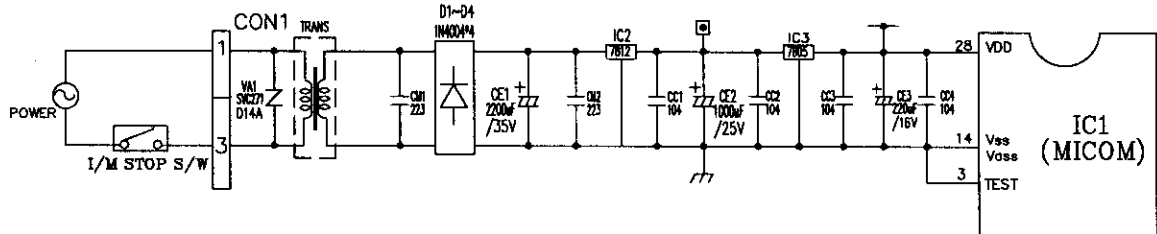

The secondary party of transformer consists of power (12Vdc) for driving display and relay and power (5Vdc) supplying power to MICOM and IC.

In this case, voltage at each part is as follows:

| Part | Both ends of VA1 | Both ends of CE2 | Both ends of CE3 |
|---------|------------------|------------------|------------------|
| Voltage | 115Vac | 12Vdc | 5Vdc |

VA1 is parts for preventing over-voltage and noise and plays a role of protecting elements of the secondary part of transformer as the inside of element becomes short and is broken and power fuse is cut off when power of more than 175V is applied.

7-4-2 Vibration circuit

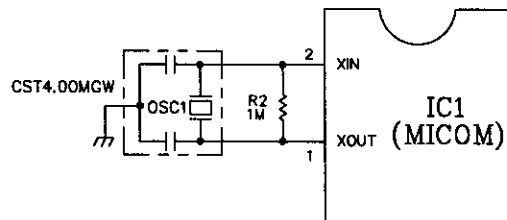

Circuit used for synchronous clock generation for transmitting/receiving information of the inside logic elements of IC and basic time generation for calculating time. Rated parts must be used as counting time is changed at the IC1 or the OSC1 does not operate if SPEC would be changed.

7-4-3 Reset circuit

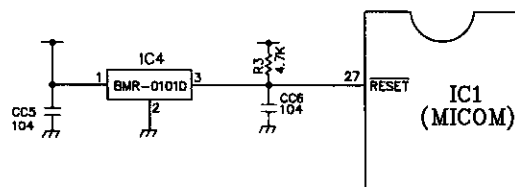

The reset circuit is a circuit that initializes various parts such as RAM, etc inside of the MICOM (IC1) and starts the whole of function from the initial status and 'low' voltage is applied for a constant time (10ms) at the reset terminal of the MICOM at the start of power input.

The reset terminal is at 5V during general operation (the MICOM does not operate in the defect of the reset IC).

7-4-4 Load drive circuit

1. Load drive status check

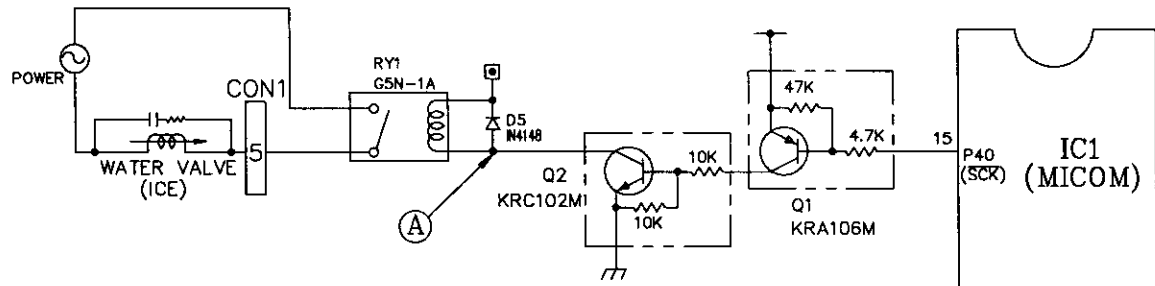

| Load Type | | Water Valve |
|----------------------|-----|-------------|
| Measurement Location | | (A) |
| Condition | ON | 1V below |
| | OFF | 12V |

7-4-5 ICE MAKER drive/circuit

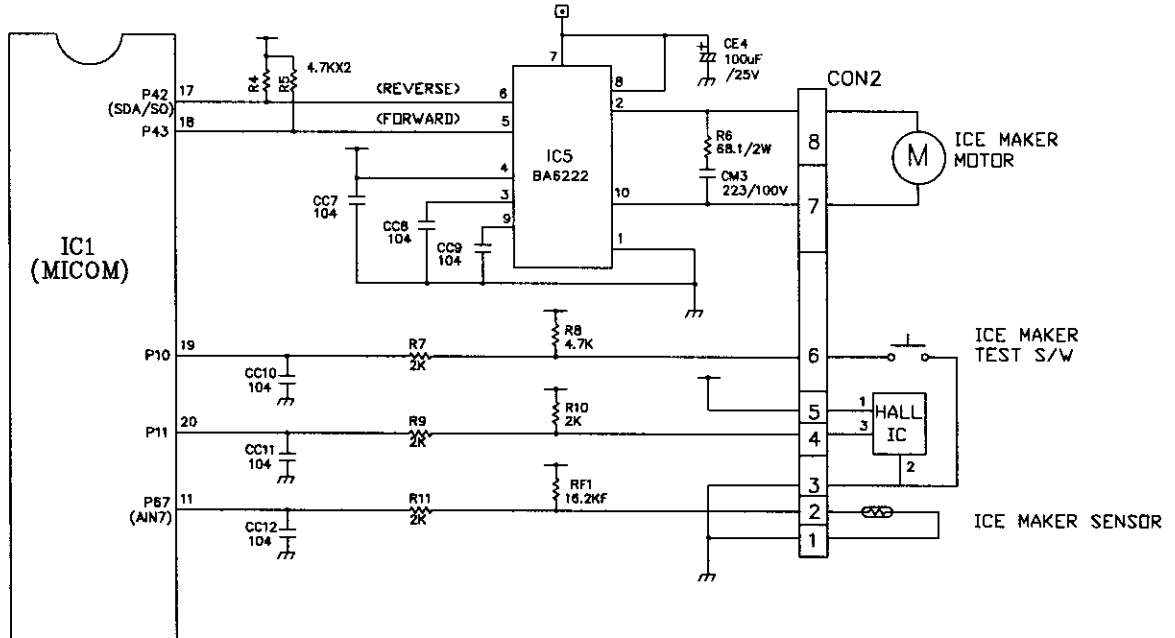

This circuit is a circuit used to embody functions such as ice-removing, full-ice detection, level noise, and ice-making temperature detection of ice-making tray (ice-making container).

7-5 Main PWB Assembly and Parts List

7-5-1 MAIN PWB

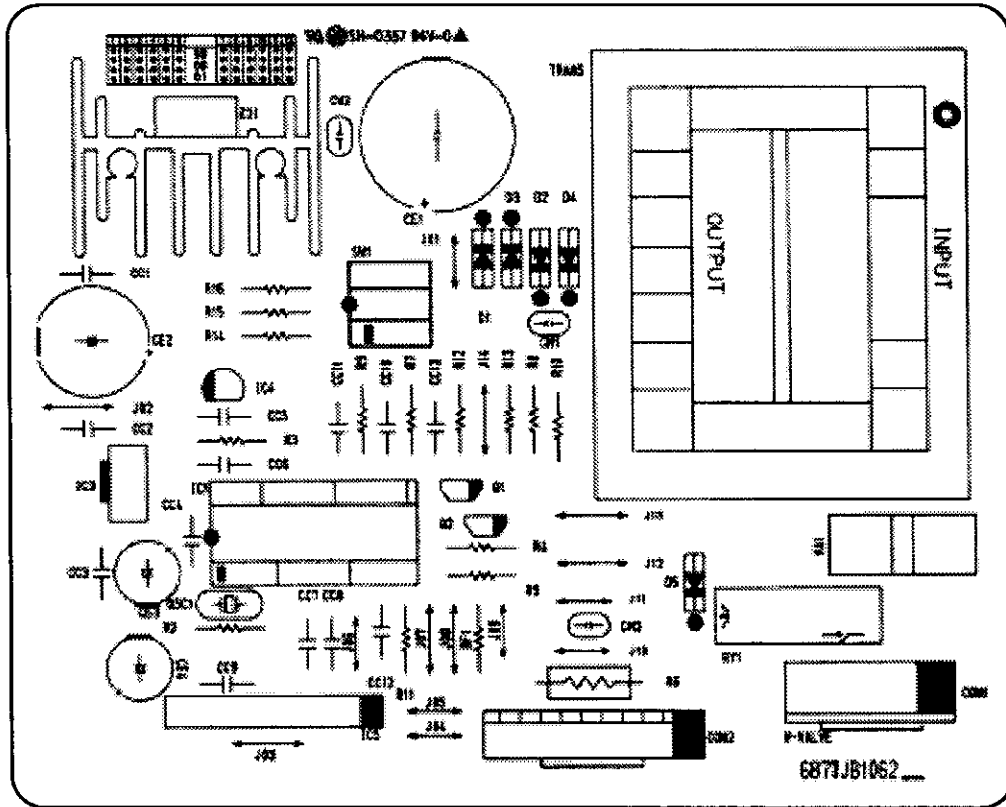

7-5-2 Replacement Part List

| NO. | DWG. NO. | DESCRIPTION | SPEC | MAKER | REMARK |
|-----|------------------------------|------------------|--|---------------------------|---|
| 1 | 8870.B2039 | PWB,MAIN | FR-(05-1107A) | DOO SAN | L=1.6 |
| 2 | 8170.B2002 | TRANS PCB | I:117V,O:15V | TAE SUNG | TRANS |
| 3 | 6630.B8001B | WAFER | 4202-IT-0(P-24) | JAE EUH | CON1 |
| 4 | 6630.B8004G | | SMW250-08 | YEON HD | CON2 |
| 6 | 6630.B8004D | | SMW250-04 | YEON HD | CON3 |
| 7 | 00ZZ.B2004A | MICOM CHIP | TMP87C409N | TOSHIBA | IC1(-00Z.B2004B) |
| 8 | 00RH78050B 00RE780500A | REGULATOR | (1)BA17805T (2)KA7805SP | ROHM REC | IC3 |
| 9 | 00RH178120A 00RE781200B | REGULATOR | (1)BA17812T uPC7812AHF | ROHM NEC | IC2 |
| 10 | 00RE704200A 00KD010100A | RESET IC | K1A7042P BMR-0101D | K.E.C KODENSHI | IC4 |
| 11 | 6920.B2003A | RELAY | G5N-1 | OMRON | RY1 |
| 12 | 570-00012A 570-00012B | RESONATOR | GST4.00MGW GST4.00MGW-1F01 | MURATA | OSC1 (=6212A09002B) |
| 13 | 572-00001C (=6102.B8003A) | VARISTOR | (1)INR14D471 (2)SVC4710-14A | L JIN SAMHWA | VA1 |
| 14 | 6102.B8001B | | (1)INR14D621 | L JIN | |
| 15 | 6102.B8001A | | (2)SVC6210-14A | SAMHWA | |
| 16 | 572-00001D 6102.B8003A | VARISTOR | (1)SVC2710-14A (2)INR14D271 | SAMHWA L JIN | |
| 17 | 00D414808B | | SWITCHING DIODE | 1N4148 | (1)P C (2)ROHM |
| 18 | 00D400408CC | DIODE,RECTIFER | 1N4004 | (1)P C (2)ROHM | D1~D4 |
| 19 | 6600.B8003A | DIP S/W | 3P,DIP | OTAX | SW1 |
| 20 | 00RH622200A | DRIVE IC | BA6222 | ROHM | IC5 |
| 21 | 00CE2208J618 | ELE CAPACITOR | 2200uF/35V | | CE1 |
| 22 | 00CE1081H618 | | 1000uF/25V | | CE2 |
| 23 | 00CE1071H638 | | 100uF/25V | (1)SAM HWA | CE4 |
| 24 | 00CE4771H618 | | 470uF/25V | TAE YANG | |
| 25 | 00CE2271F638 | | 220uF/16V | | CE3 |
| 26 | 00CE4781H638 | | 47uF/25V | | |
| 27 | 00CE2231H409 | MINI CAPACITOR | 223/100V | SEEL | CM1~CM3 |
| 28 | 00CK1020H908 | ELE CAPACITOR | 102/25V | | |
| 29 | 00CK2230H908 | | 223/25V | TAE YANG | |
| 30 | 00CK1040H908 | | 104/50V | | CC1~12 |
| 31 | | | | | |
| 32 | 00RD0682H609 | R,CARBON FILM | 68J 1/2W | | R6 |
| 33 | 00RD2001G608 | | 2KJ 1/4W | (1)DO YANG (2)K-OHM | R7,R9~11 |
| 34 | 00RD4701G609 | | 4.7K 1/4W | (3)DOONG HO (4)SUNG YO | R3~5,8 R14~16 |
| 35 | 00RD1004G608 | | 1MJ 1/4W | | R2 |
| 36 | 00RH612G408 | R,METAL FILM | 16.2KF 1/4W | | RF1 |
| 37 | | | | | |
| 38 | | | | | |
| 39 | 0TR106009AC | TRANSISTOR | KRA106M(KR2206) | K.E.C | Q1 |
| 40 | 0TR102009AB | TRANSISTOR | KRC102M(KRC1202) | K.E.C | Q2 |
| 41 | 43607015 | JUMP WIRE | 0.6*5mm 0.6*8mm 0.6*10mm 0.6*12.5mm 0.6*15mm | | J01,J04~J08 J09~J11,CC13 J02,J03,J07 J05,J12~J14 |
| 42 | 4920.B3003A | HEAT SINK(12V) | (=572-00004A) | | (IC2) |
| 43 | 4920.B3001A | HEAT SINK(5V) | (=572-00002A) | | |
| 44 | 138FD302418 | SCREW | ASSEMBLE WITH H/SINK | | |
| 45 | 491111004 | SOLDER | ALMIT KR-190MA | | HEE SUNG SOLD |
| 46 | 491111004 | SOLDER LEAD BOND | H63A | | |
| 47 | 583333105 | FLUX AUTO | JS71 | KOKI | |
| 48 | | | | | |

7-6 PWB DIAGRAM

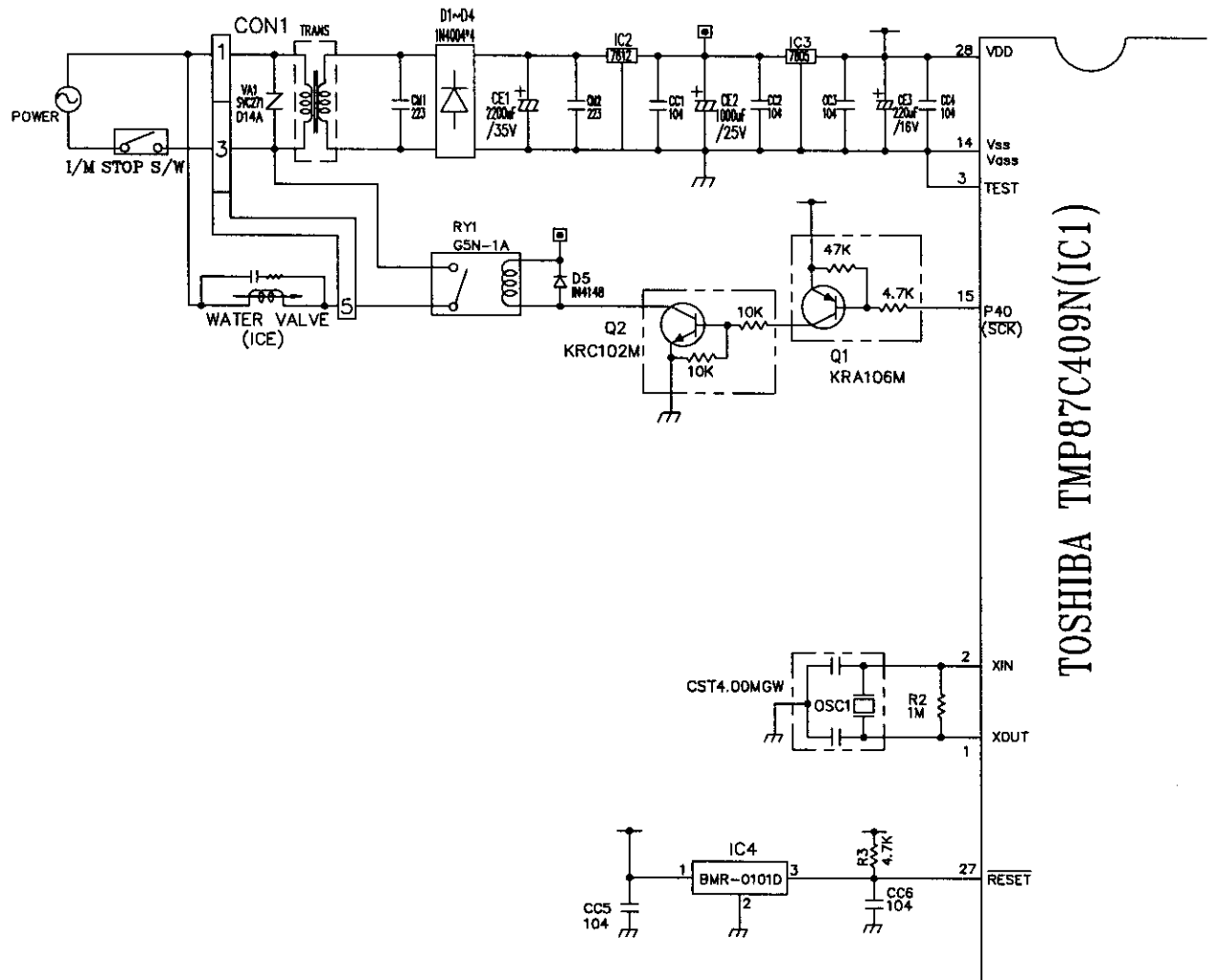

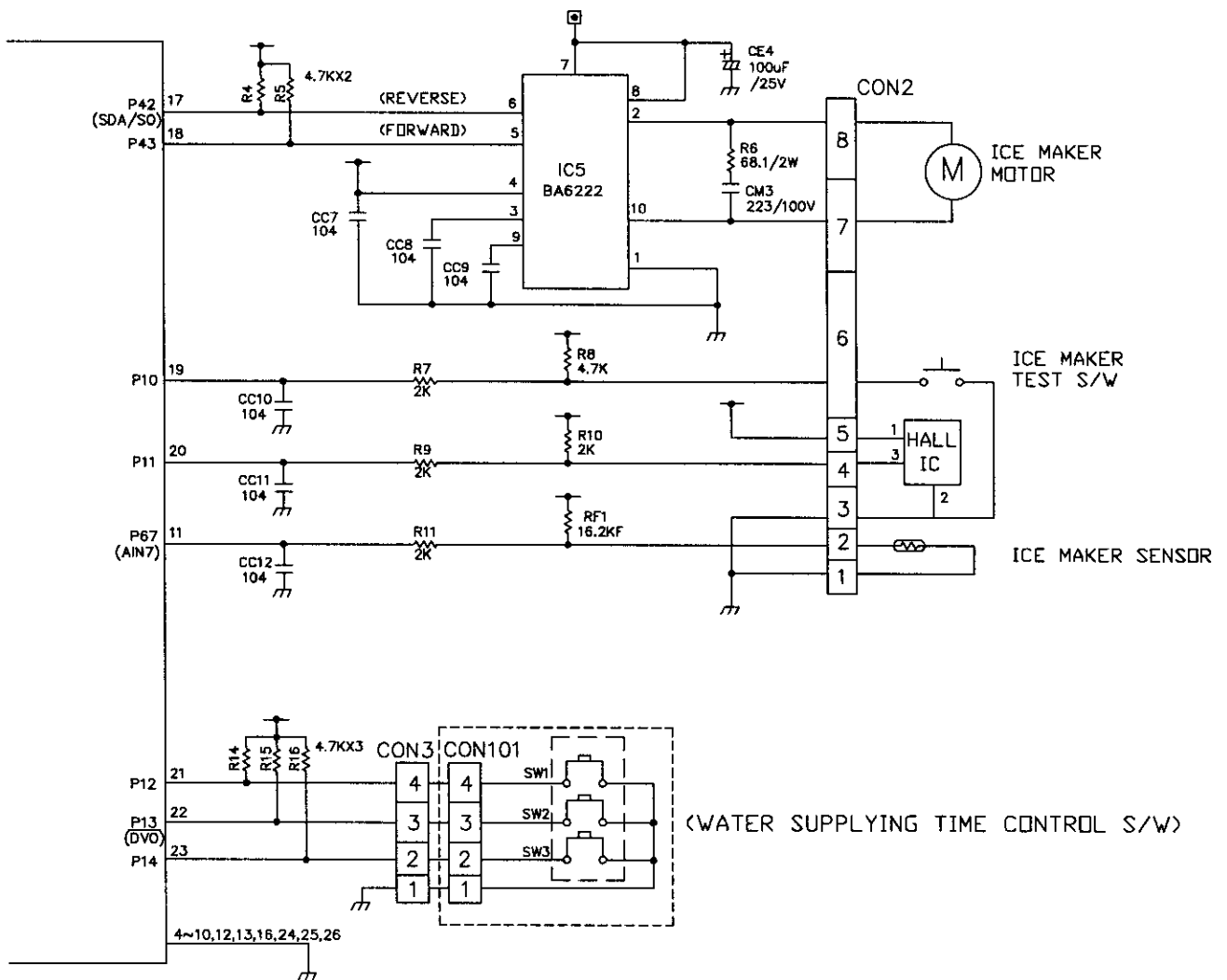

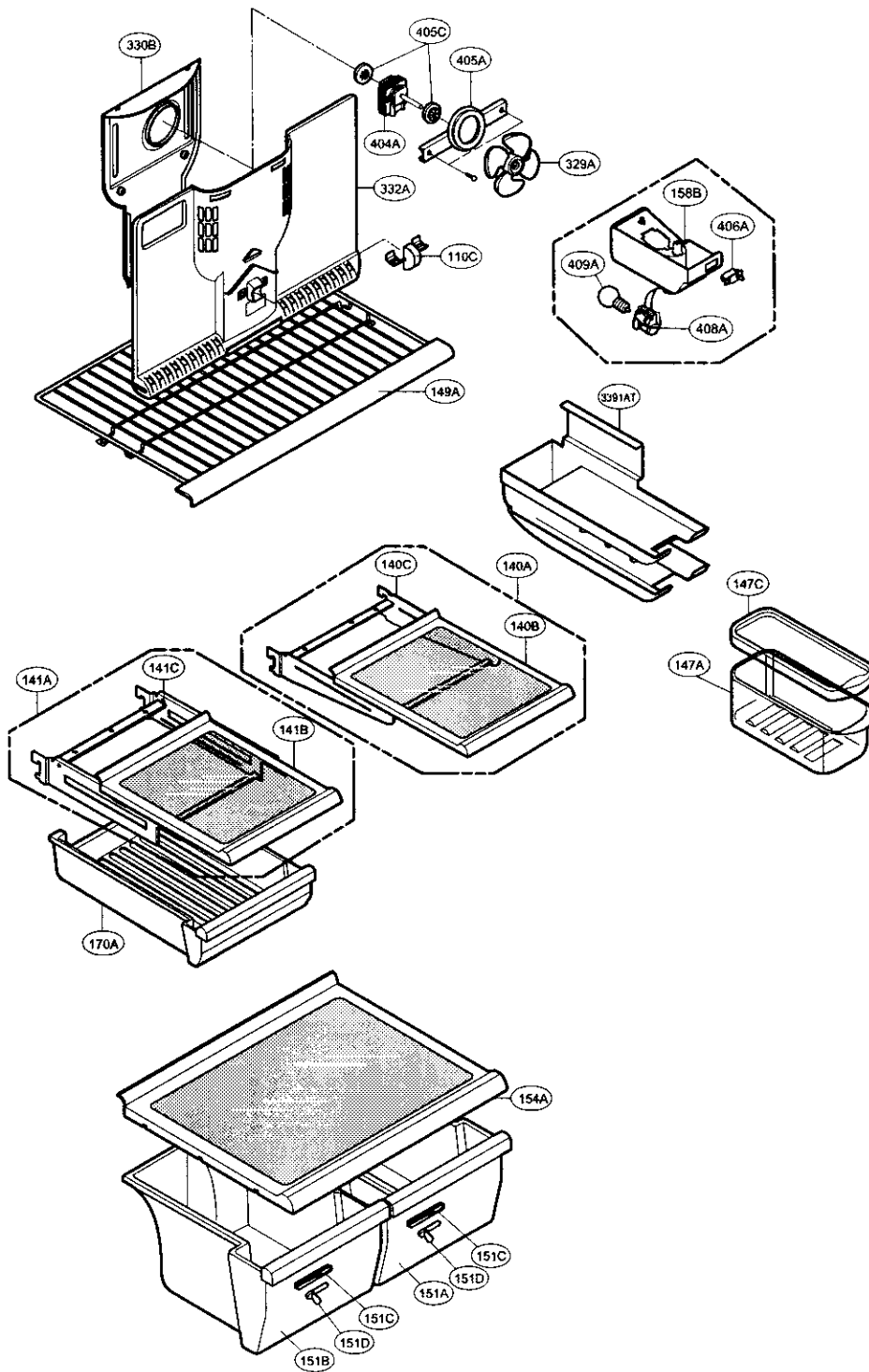

ICE MAKER PART

