

This Owner's Manual is provided and hosted by [Appliance Factory Parts](http://www.appliancefactoryparts.com).



# PITCO FBG24 Owner's Manual

[Shop genuine replacement parts for PITCO FBG24](#)



[Find Your PITCO Deep Fryer Parts - Select From 19 Models](#)

----- Manual continues below -----



**IMPORTANT FOR FUTURE REFERENCE**

Please complete this information and retain this manual for the life of the equipment:

Model #: \_\_\_\_\_

Serial #: \_\_\_\_\_

Date Purchased: \_\_\_\_\_

# Installation and Operation Manual

## Covering Models

### FBG18 and FBG24



**THIS MANUAL MUST BE RETAINED FOR FUTURE REFERENCE**

## **FOR YOUR SAFETY**

**DO NOT store or use gasoline or other flammable vapors or liquids in the vicinity of this or any other appliance.**

## **WARNING**

**Improper installation, alteration, service or maintenance can cause property damage, injury or death. Read the installation, operating and maintenance instructions thoroughly before installing or servicing this equipment.**

### **TO THE PURCHASER**

Post in a prominent location the instructions to be followed in the event that an operator smells gas. Obtain this information from your local gas supplier.

### **WARNING**

There is an open flame inside this appliance. The unit may get hot enough to set nearby materials on fire. Keep the area around the appliance free from combustibles.

### **WARNING**

**DO NOT** supply the appliance with a gas that is not indicated on the data plate. If you need to convert the appliance to another type of fuel, contact your dealer.

### **WARNING**

**DO NOT** use an open flame to check for gas leaks!

### **WARNING**

If gas flow to appliance is interrupted, or pilots extinguish, wait 5 minutes before attempting to relight the pilot to allow any residual gas in appliance to dissipate.

### **WARNING**

Ensure that the appliance can get enough air to keep the flame burning correctly. If the flame is starved for air, it can give off a dangerous carbon monoxide gas. Carbon monoxide is a clear odorless gas that can cause suffocation.

### **WARNING**

Adequate means must be provided to limit the movement of this appliance without depending on the gas line connection. Single appliances equipped with legs must be stabilized by installing anchor straps. All appliances equipped with casters must be stabilized by installing restraining

chains. If a flexible gas line is used, an additional restraining cable must be connected at all times when the appliance is in use.

### **WARNING**

An appliance equipped with casters and a flexible gas line must be connected to the gas supply with a quick disconnect device. This quick disconnect must comply with ANSI Z24.41. To limit the movement of the appliance without depending on the connector or quick disconnect, a restraining cable must also be installed.

### **WARNING**

Models with electric controls are equipped with an oil proof electrical supply cord, with a three-prong safety plug. This is to protect operators from electrical shock hazard in the event of an equipment malfunction. **DO NOT** cut or remove the grounding (third) prong from this plug.

### **WARNING**

This appliance, when installed, must be electrically grounded in accordance with local codes, or in the absence of local codes, with the *National Electrical Code, ANSI/NFPA 70, or the Canadian Electrical Code, CSA C22.2*, as applicable.

### **WARNING**

The power supply must be disconnected before servicing or cleaning this appliance.

### **WARNING**

Do not attempt to move this appliance when the unit is at operating temperature. Serious personal injury could result if skin comes in contact with the hot surfaces.

### **WARNING**

**DO NOT** sit or stand on this appliance. Serious injury could result from falling or contact with hot shortening/oil.

# Table of Contents

<b><u>Section</u></b>	<b><u>Page</u></b>
Installation	
Checking your new Pitco Appliance . . . . .	1
<u>Assembly and Leveling</u>	
Leg and Caster Adjustment . . . . .	1
Installation Clearances . . . . .	2
Gas Connection . . . . .	2
Quick Disconnect Gas Connection . . . . .	3
Fuel Supply Line Leak and Pressure Testing . . . . .	3
Electrical Connection . . . . .	3
Ventilation and Fire Safety Systems . . . . .	3
<u>Initial Adjustments</u>	
Burner Ignition Systems . . . . .	5
Lighting Instructions . . . . .	5
Pilot Flame Adjustment . . . . .	5
Main Burner System Adjustment . . . . .	6
Initial Cleaning . . . . .	6
Operation	
<u>Filling the Tank</u>	
Filling the Tank with Liquid Shortening/oil . . . . .	8
Filling the Tank with Solid Shortening/oil . . . . .	8
<u>Operating Instructions</u>	
Appliance Start-Up . . . . .	9
Appliance Shut-Down . . . . .	9
Power Failure . . . . .	9
Filtering Instructions . . . . .	10
Maintenance and Adjustments	
<u>Daily Cleaning</u> . . . . .	11
Filter pan and Pickup Assembly Cleaning . . . . .	11
<u>Thermostat Calibration</u>	
Thermostat Calibration Check (Standard) . . . . .	11
<u>Weekly Cleaning</u>	
General Cleaning . . . . .	12
Weekly Boil Out Procedure . . . . .	12
Ventilation Hood Maintenance . . . . .	13
Troubleshooting	
<u>Basic Troubleshooting Flow Chart</u> . . . . .	14



## **CHECKING YOUR NEW PITCO APPLIANCE**

Your new Pitco appliance has been carefully packed into one crate. Every effort has been made to ensure that it is delivered to you in perfect condition. As you unpack your new appliance, inspect each of the pieces for damage. If something is damaged, DO NOT sign the bill of lading. Contact the shipper immediately; the shipper is only responsible for 15 days after delivery. Check the packing list enclosed with your appliance to ensure that you have received all the parts to the appliance. If you are missing any parts, contact the dealer from whom the appliance was purchased. As you unpack the appliance and its accessories be careful to keep the weight of the appliance evenly distributed.

### **CAUTION**

**To prevent equipment damage and/or personal injury, do not tilt the appliance onto any two of its casters or legs, or pull the appliance by the flue vent.**

Locate your Pitco warranty and fill in the serial number of the appliance and the date received. You will find the serial number on the date plate located inside the door. Put your warranty card in a safe place for future reference. DO NOT return the card to Pitco.

## **ASSEMBLY**

When you receive your appliance it is completely assembled with the possible exception of the legs (or casters).

### **Leg/Caster Installation and Leveling**

This appliance must be installed with legs or casters; it cannot be curb mounted. Curb mounting will seriously inhibit this appliance's ability to effect proper combustion.

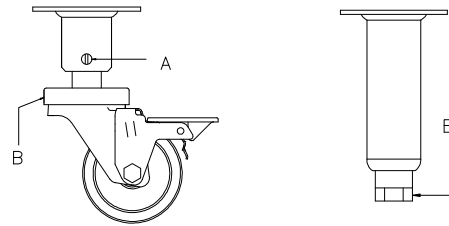

### **WARNING**

**This appliance must be installed with the legs or casters provided by the manufacturer.**

### **WARNING**

**Do not install legs or casters, or perform leveling procedure when unit is in operation or full of cooking medium. Serious injury could result.**

Required tools: 7/16 " wrench and socket and a large pair of water pump pliers. The legs/casters must be installed before connecting the appliance to the gas supply. The legs provide the necessary height to meet sanitation requirements and assure adequate air supply to the combustion system. Use the following procedure.

- a. Lay the appliance on its back, being careful not to damage the flue area by pulling on it. Protect the outside of the appliance with cardboard or a drop cloth when laying it down.
- b. Attach each leg/caster with the hex head screws and nuts supplied. Each leg/caster requires four 1/4-20 x 5/8" hex head screws and nuts. Insure that all screws are tight.
- c. Mount the screws from the inside of the appliance with the nut on the outside (bottom) of the appliance. The nuts have lock washers attached to them, therefore it is not necessary to use lock washers
- d. When all four legs/casters are securely mounted, stand the unit up, being careful not to put too much weight on any one leg. Adjust the height and level the appliance by adjusting the leveling devices (B) with water pump pliers. On casters, loosen 2 screws (A) before leveling, then retighten.

## **INSTALLATION**

If you have completed the above steps that are applicable to the appliance you purchased, the appliance is now ready to be installed. Although it may be possible for you to install and set up your new appliance, it is **STRONGLY** recommended that you have this done by qualified professionals. A qualified professional will ensure that the installation is safe and meets local building and fire codes.

### **WARNING**

**DO not obstruct the flow of combustion, ventilation or air openings around the appliance. Adequate clearance around the appliance is necessary for servicing and proper burner operation. Ensure that you meet the minimum clearance requirements specified in this manual.**

### **Installation Clearances**

The clearances shown below are for combustible and non-combustible installations and will allow for safe and proper operation of your appliance.

	Combustible Construction	Non-Combustible Construction
Back	6 in. (15 cm)	0
Sides	6 in. (15 cm)	0
Floor	4 <sup>3</sup> / <sub>4</sub>	4 <sup>3</sup> / <sub>4</sub>

In addition to the above clearances there must also be at least 28 inches of aisle space in front of the unit.

### **Gas Connection**

Your appliance will give you peak performance when the gas supply line is of sufficient size to provide the correct gas flow. The gas line must be installed to meet the local building codes or National Fuel Gas Code ANS Z223.1 and NFPA 54 (latest editions). In Canada, install the appliance in accordance with CSA B149.1 or .2 and local codes. Gas line sizing requirements can be determined by a qualified installation professional, your local gas company or by referring to the National Gas Fuel Code, Appendix C, Table C-4 (for natural gas) and Table C-16 (for propane). The gas line needs to be large enough to supply the necessary amount of fuel to all appliances without losing pressure to any appliance. A properly sized and installed gas line will deliver a minimum supply pressure of 7.0 inches w.c. (natural gas) and 12.0 inches (propane) to all appliances connected to the supply line, operating simultaneously at full demand.

Each appliance is equipped to operate on one certain fuel type. The type of fuel with which the appliance is intended to operate is stamped on the data plate, which is attached to the inside of the door.

### **WARNING**

**NEVER supply the appliance with a gas other than the one that is indicated on the data plate. Using the incorrect gas type will cause improper operation and could result in serious injury or death. If you need to convert the appliance to another type of fuel, contact the dealer you purchased it from.**

### **NOTICE**

**NEVER use an adaptor to make a smaller gas supply line fit the appliance connection. This may not allow proper gas flow for optimum burner operation, resulting in poor performance and improper operation.**

# INSTALLATION



## Quick Disconnect Gas Connection

Gas appliances equipped with casters must be installed with connectors that comply with the Standard for Movable Gas Appliances, ANSI Z21.69 • CSA 6.16 latest edition. This connection should include a quick disconnect device that complies with the Standard for Quick Disconnect Devices for Use With Gas Fuel, ANSI Z21.41 • CSA 6.9 latest edition. When installing a quick disconnect you must also install adequate means for limiting the movement of the appliance without depending on the connector and quick-disconnect device or it's associated piping to limit the movement of the appliance. The restraining device should be attached to the appliance on the back panel.

## Fuel Supply Line Leak and Pressure Testing

The fuel supply system must be tested before the appliance is used. If the fuel line is going to be tested at a pressure greater than ½ PISG (3.45 kPa), insure that that appliance is disconnected from the fuel line. If the fuel line is to be tested at a pressure equal to or less than ½ PSIG (3.45 kPa), the appliance can be connected during the test, but the unit's gas valve must be shut. Test all gas line connections for leaks with a solution of soap and water when pressure is applied.

## Electrical Connection

The electrical connection used by this appliance must comply with local codes. If there are no local codes that apply, refer to the National Electrical Code (NEC), ANSI/NFPA 70 to install the service. In Canada, refer to CSA Standard C22.2 and local codes. If your appliance is equipped with electrical or electronic controls, the power requirements are listed below.

	North America	International
Input Voltage	120 VAC, 50/60 Hz	220, 230 or 240 VAC 50/60 Hz
Current per unit	1.0 Amp	0.5 Amps
Filter System Current	7.0 Amps	4.0 Amps

The appliance must be grounded in accordance with local code; if there is no local code, comply with the NEC and ANSI/NFPA No. 70 latest edition. It is advised that this power supply be plugged into a wall receptacle that is controlled by the ventilation control. This will prevent the appliance from being operated without the ventilator on.

### WARNING

**If your appliance is uses line current, it is equipped with an oil proof, electrical supply cord with a three-prong safety plug. This is to protect operators from electrical shock hazard in the event of an equipment malfunction. DO NOT cut or remove the grounding (third) prong from this plug; it should be plugged into a properly grounded three-prong receptacle.**

## Ventilation and Fire Safety Systems

Your new appliance must have proper ventilation to function safely and properly. Exhaust gas temperatures can reach as high as 1100 °F (593 °C). Therefore, it is very important to install a fire safety system. Your ventilation system should be designed to allow for easy cleaning. Frequent cleaning and proper maintenance of the ventilation system and the appliance will reduce the chances of fire. The following tables contain a list of reference documents that will provide guidance on ventilation and fire safety systems. It is not necessarily complete. Additional information can be obtained from CSA International, 8501 East Pleasant Valley Road, Cleveland, OH, 44131 or visit their website at [www.csa-international.org](http://www.csa-international.org).

### Hoods and Ventilation Systems

TOPIC	UL Document	National Fuel Gas Code Document
Exhaust Hoods	ANSI/UL 70	ANSI/NFPA 96
Power Ventilators	ANSI/UL 705	ANSI/NFPA 96
Filter Units	ANSI/UL 900	ANSI/NFPA 96

### Types of Fire Extinguishers and Detection Equipment

Topic	UL Document	National Fuel Gas Code Document
CO <sub>2</sub> Type Extinguishers	ANSI/UL 154	ANSI/NFPA 12
Dry Chemical Type Extinguishers	ANSI/UL 299	ANSI/NFPA 17
Water Type Extinguishers	ANSI/UL 626	ANSI/NFPA 13
Foam Type Extinguishers	ANSI/UL 8	ANSI/NFPA 11
Sprinklers	ANSI/UL 199	ANSI/NFPA 13
Smoke Detectors	ANSI/UL 268	ANSI/NFPA 72
Fire Detection Thermostats	ANSI/UL 521	ANSI/NFPA 72

It is essential that the appliance be operated only when adequate ventilation is provided. Your ventilation hood should be properly maintained. A qualified installation professional should ensure that the hood is operating properly in conjunction with the appliance. Inadequate ventilation may not properly evacuate appliance all emissions. Excessive or unbalanced ventilation may cause drafts, which could interfere with proper operation of the pilot and burners. Leave at least 18 inches of open space between the flue of the appliance and the intake of the exhaust hood.

#### CAUTION

**Ensure that your ventilation system does not cause a down draft at the appliance's flue opening. A down draft will not allow the appliance to exhaust properly and will cause overheating, which may cause permanent damage. Damage caused by down drafts will not be covered by the warranty. NEVER allow anything to obstruct the flow of combustibles or ventilation exiting the appliance. NEVER place anything on top of the flue area, or block the flue in any way.**

#### NOTICE

**NEVER connect the ventilation blower or hood directly to the flue of this appliance. The resulting increased flow of air through the combustion system will cause improper operation, poor temperature recovery, poor ignition and could extinguish the pilot.**

### INITIAL ADJUSTMENTS

After your appliance has been properly installed as described in the installation section of this manual, it will need to be adjusted to ensure that it will perform as designed. These adjustments must be performed by a qualified person. To perform these adjustments the following tools will be needed:

- Manometer
- DC Milliammeter
- Digital Thermometer (Temperature Probe)

Before you begin filling and adjusting the appliance, perform the following visual checks:

- a. After the appliance is in its permanent location, check the levelness. Any additional leveling that is necessary can be performed as previously described.
- b. Check the temperature probe and high limit bulb (in the tank) to ensure that the mounting screws are tight.

# INSTALLATION



- c. Review the installation portion of this manual and ensure that all steps have been followed and executed properly.

## Burner Ignition Systems

### CAUTION

Before proceeding any further, fill the tank with WATER. Water is used for the installation adjustments because the temperature will never exceed 212°F (100°C), thereby allowing plenty of adjustment time. Never let the water level go below the MIN LEVEL mark stamped on the tank.

### WARNING

During operation there is an open flame inside this appliance. The unit may get hot enough to set near by materials on fire. Keep the area around the appliance free from combustibles.

## Lighting Instructions

For Electronic Pilot refer to the following instructions.

NOTE: There is nothing to manually light on the electronic ignition system. Pilot ignition is performed and controlled by the electronic ignition system.

- a. Open the gas supply valves to the appliance.
- b. Turn the thermostat control knob counterclockwise to the OFF position.
- c. Turn the gas valve knob to the ON position.
- d. Turn the appliance ON/OFF switch to the ON position. If the appliance is equipped with the optional melt cycle place the switch in the MELT ON position.
- e. Turn the thermostat to the desired temperature setting. The main burners will light and be controlled by the thermostat.
- f. The POWER ON light will come on and remain on as long as the power switch is in the ON position. The HEATING light will be illuminated when the main burners are on.

## Pilot Flame Adjustment

For electronic pilots, refer to the following instructions. Perform this procedure with the pilot lit

Note: This procedure requires the use of a DC milliammeter.

- a. Connect the DC milliammeter between the flame sensor terminal and the flame sensor lead. Observe proper polarity: if the meter needle goes below 0, reverse the leads. The current reading must be 0.15 mA or greater.
- b. Adjust the current reading to the required level by adjusting the pilot flame. Remove the cap screw to expose the pilot adjustment screw. Turning the pilot adjustment screw clockwise will decrease the size of the pilot flame and flame sense current. Turning the pilot adjustment screw counterclockwise will increase the pilot flame size and the flame sense current.

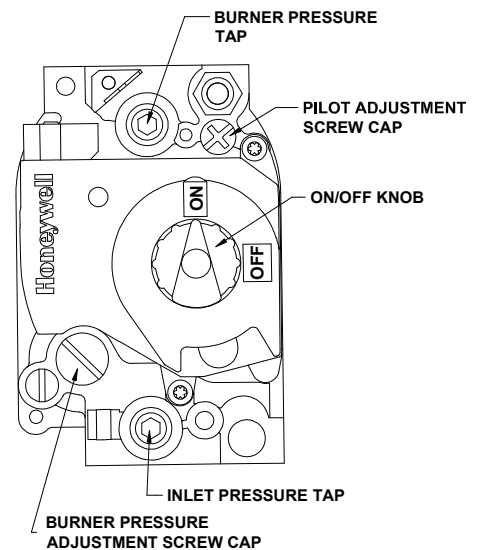

- c. Rotate the screw in the direction needed to achieve a reading of 0.15 mA or greater.

**Note:** Allow 3 to 5 minutes between flame adjustments to allow the reading to stabilize.

- d. Once the pilot flame has been adjusted properly, replace the cap screw and remove the milliammeter.

## Main Burner System Adjustment

For the main burners to operate the gas supply valve must be open and the thermostat must be turned on. For models with electric controls, the main power switch must be on. The main burners receive gas from the main gas supply through the thermostatically controlled valve. When the thermostat is turned up the gas control valve opens.

The main burners must be adjusted to deliver optimum flame. Refer to the following procedure to adjust the main burners.

### CAUTION

**Before proceeding any further, fill the tank with WATER. Water is used for the installation adjustments because the temperature will never exceed 212°F (100°C), thereby allowing plenty of adjustment time. Never let the water level go below the MIN LEVEL mark stamped on the tank.**

- a. Ensure that the main gas valve is shut off, remove the manifold pressure tap plug and connect an accurate pressure gauge (range of 0-16 " w.c. in 0.1" increments) or manometer.
- b. Turn on this and all appliances connected to the gas supply line and light their main burners. The pressure reading of the installed pressure gauge should not drop from the required installation pressure. Any loss of pressure indicates inadequate supply line installation, which will cause poor performance of all appliances during peak usage.
- c. The installed pressure gauge should be the same,  $\pm 0.1$ " W.C., as that marked on the data plate on the inside door of the appliance. If the pressure is correct, go to step e, if it is not, adjust the pressure as outlined in step d.
- d. To adjust the pressure, remove the regulator adjustment screw cap and, with a flat head screwdriver, adjust the regulator screw until the proper burner pressure is reached. Turning the screw clockwise will increase the burner pressure. Turning the screw counterclockwise will decrease the burner pressure.
- e. When the pressure is correct, replace the regulator adjustment screw cover.
- f. Turn off the ALL appliances, shut the main gas valve to your Pitco appliance and remove the pressure gauge. Apply pipe joint compound to the manifold pressure tap plug and reinstall it.

## Initial Cleaning

When your appliance is shipped, many of its parts are covered with a thin coat of oil for protection. Before the appliance is ready for cooking it must be cleaned. This will remove the oil coating and any foreign matter that may have accumulated during storage and shipment. Refer to the following procedure to clean the appliance.

- a. Fill the tank with water. Light the pilot, turn the appliance on and set the thermostat to 200°F (93 °C).
- b. Allow the appliance to heat for 15 minutes. Add Pitco cleaner to the water, stirring with the cleaning brush to ensure that the cleaner dissolves thoroughly.



## **CAUTION**

**DO NOT leave the appliance unattended during cleaning. Never let the water level go below the “Min Level” mark stamped on the tank.**

- c. Using the cleaning brush, scrub the inside of the tank to remove the protective coating.
- d. When cleaning is complete turn the appliance off and drain the water into a container suitable for hot water and dispose of it.

## **WARNING**

**Wear protective gloves and clothing when cleaning and draining the appliance and when disposing of water. The water is extremely hot and can cause severe injuries.**

- e. When the tank has cooled, rinse thoroughly with cool water. Continue to rinse the tank until the cleaner has been completely and thoroughly rinsed from the tank.
- f. Using a clean dry cloth, wipe out all of the water. Be very thorough when removing the water, as any residual water will cause hot shortening/oil to splatter out of the appliance.

## **NOTICE**

**Mild steel tanks must be wiped down/coated thoroughly with oil to keep the tank from rusting**



## FILLING THE TANK

Both liquid and solid shortening/oil can be used in this appliance, but liquid is preferred. If solid shortening/oil is used it is recommended that you melt the shortening/oil before adding it to the appliance. You can melt solid shortening/oil in the appliance, but you must be very careful not to scorch the shortening/oil.

### Filling the tank with liquid shortening/oil

To fill the tank with liquid shortening/oil refer to the following procedure.

- a. Ensure that the drain valve is completely closed and that there is no residual moisture in the tank.
- b. Fill the tank with shortening/oil. You may fill the tank to the LEVEL mark or slightly below: the shortening/oil will expand slightly when it heats up, raising the level slightly.

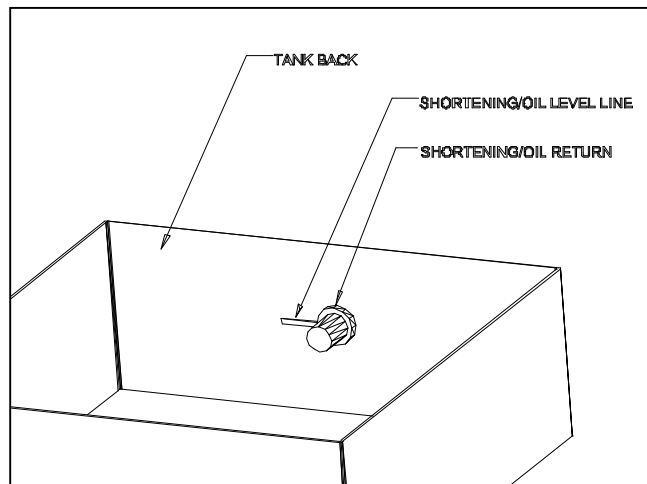

### Filling the tank with solid shortening/oil

To fill the tank with solid shortening/oil refer to the following procedure.

#### **WARNING**

**NEVER melt blocks of solid shortening/oil without first cutting it into small cubes and packing firmly into tank. This will cause a fire and could result in personal injury.**

- a. Ensure that drain valve is completely closed and that there is no residual moisture in the tank.
- b. Cut the solid shortening/oil into cubes no larger than one inch. **ALWAYS** pack the shortening/oil firmly into the tank. **DO NOT** leave any large air gaps. Use care when packing the solid shortening/oil into the tank. **DO NOT** bend or break the temperature or high limit sensor probes. If these are damaged the appliance will not function properly.
- c. Once the appliance tank is firmly packed with shortening/oil, the shortening/oil must be melted. Melt the shortening/oil by following the Appliance Start Up procedure and choosing the Melt Cycle function.

## OPERATING INSTRUCTIONS

To ensure the quality of the food you cook in this appliance, follow the preparation instructions from the food manufacturer. Using the best shortening/oil makes the best fried foods. The best shortening/oil will last longer than lower grade shortening/oil and save you money. When not in use, the shortening/oil should be cooled and covered to prevent contamination.

**WARNING**

This appliance has been installed using restraining devices to prevent accidental tipping or movement. **DO NOT** attempt to move the appliance when it is in use or has hot liquid in it. Splashing hot liquids can cause severe burns.

**WARNING**

Water and shortening/oil **DO NOT** mix. Keep liquids away from hot shortening/oil. Dropping liquid frozen foods into the hot shortening/oil will cause violent boiling.

**Appliance Start-Up**

**WARNING**

**DO NOT start the appliance without filling the tank with shortening/oil first!**

To start up the appliance refer to the following instructions.

- a. Ensure that the tank is full of shortening/oil. If using solid shortening/oil, make sure that it is packed properly, leaving no voids or excessive air gaps (refer to section in this manual for filling the tank with solid shortening/oil).
- b. Ensure that drain valve is fully closed.
- c. On controller, switch melt switch to melt position. Turn the thermostat knob to desired temperature. Turn the power switch (I/O) to the ON ( I ) position. The appliance will execute its melt cycle and then bring the shortening/oil to the chosen setpoint.

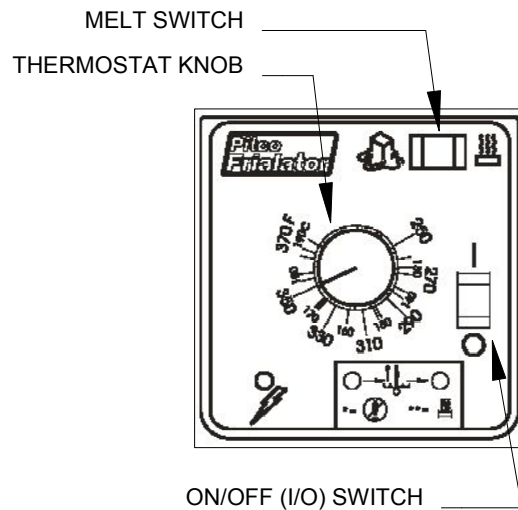

**Appliance Shutdown**

There are two shutdown modes of appliance operation: STANDBY and COMPLETE. The standby mode removes the ability of the appliances main burners to operate. Complete shutdown turns off the gas supply to the appliance.

**STANDBY** Turn the power switch (I/O) on the controller to the OFF (O) position. The cooker is now in Standby and can remain this way for only brief periods of time. NEVER leave the appliance in standby mode for prolonged periods or overnight.

**COMPLETE** Turn the power switch (I/O) on the controller to the OFF (O) position. Turn the ON/OFF knob on the gas valve clockwise to the OFF position. The appliance is now completely shut down and can be cleaned and filtered if desired.

**Power Failure**

**CAUTION**

**DO NOT attempt to operate this appliance during a power outage.**

If your appliance is supplied with AC power and it is interrupted or removed for any reason during operation, the appliance will shut down. Wait five minutes after the power is restored before attempting to restart the appliance. This will allow time for any gas that may have accumulated in the burner or tubes to dissipate. To restart the appliance, follow the appliance start up procedure in this manual.



## **FILTERING INSTRUCTIONS**

It is recommended that the shortening/oil be filtered, at a minimum, on a daily basis. Filtering removes suspended food particles from the shortening/oil, preventing them from burning and imparting an undesirable taste to your food products. Proper filtering will increase the usable life of your shortening/oil. Old shortening/oil has a lower flash point and foams up more than clean oil.

For models with filter option refer to the following instructions.

### **WARNING**

**Shortening/oil, when it is at operating temperatures, is very hot and dangerous! Use extreme caution when filtering! Use proper protective gear, such as insulated gloves, aprons, face shield and sleeves when filtering or otherwise handling hot shortening/oil.**

- a. Ensure that filter pan is placed properly in appliance and that filter pickup is clean and serviceable. If the filter pickup is not serviceable, clean it per the instructions in this manual.

**DO NOT run the filter without a filter paper on the pickup assembly.**

- b. Ensure that the pickup tube assembly is placed snugly into the pickup block located on the floor of the appliance.
- c. Perform the appropriate appliance shut down for your appliance per the instructions in this manual.

### **WARNING**

**Ensure that the appliance is turned OFF before opening the drain valve.**

- d. Open the drain valve for the fryer to be filtered and allow the shortening/oil to drain into the filter pan.

### **WARNING**

**NEVER drain more than one tank at a time into the filter pan. The filter pan will only hold one (1) tank at a time.**

- e. Place Filter ON/OFF ( I/O ) switch in the ON ( I ) position. Pull the red return handle under the tank that the shortening/oil will be returned to forward. The pump will begin to return shortening/oil to the tank.
- f. Allow any debris in the tank to be rinsed into the filter pan with stream of returning shortening/oil. You can use the cleaning brush and cleaning rod to aid in removing debris from the tank.
- g. Once all debris has been rinsed from the tank, close the drain valve and allow the tank to refill. To ensure that filter lines are purged, allow the filter to run for 15 seconds after all shortening is returned to the tank. Additionally, it may be necessary to add a small amount of shortening/oil to bring the shortening/oil back to the OIL LEVEL line.
- h. It may be necessary to repeat steps d through g if shortening/oil quality is not acceptable. Otherwise, you may now turn the appliance on per the instructions in this manual and resume operation.

To ensure proper operation and sanitary conditions, the filter system should be disassembled and cleaned with hot water and mild detergent daily. Refer to the CLEANING AND MAINTENANCE section of this manual for instructions.

## MAINTENANCE and ADJUSTMENTS

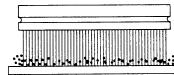

### **DAILY CLEANING**

Your appliance should be cleaned every day to maintain peak performance, proper sanitation and appearance. Perform the following procedures daily.

- a. Wipe up any shortening/oil that spills onto the exterior of the appliance. This should be done with a clean soft cloth while the shortening/oil is still warm.
- b. Use warm water with a mild detergent to clean surfaces. Be careful not to get water into the shortening/oil and be sure to completely remove any detergent from the fry tank.
- c. Use a non-abrasive scouring powder or pad to clean stains if necessary.

#### **NOTICE**

**Maintenance and repairs should be performed by qualified personnel. If you are unsure, contact the factory, factory representative to locate the nearest qualified Service Company.**

### **Filter Pan and Filter Pickup Assembly Cleaning**

Your filter pan and pickup assembly should be cleaned every day to maintain peak performance and proper sanitation. Perform the following procedures daily.

- a. Remove filter pan and filter pickup assembly from the appliance
- b. Disassemble the filter pickup assembly
- c. Soak filter pan, flush hose and all pickup assembly components in hot water and mild, grease-cutting detergent and scrub thoroughly with a non-abrasive scouring pad.
- d. Thoroughly rinse all parts and allow them to dry completely.

#### **WARNING**

**Hot shortening/oil and water, if mixed react violently. Ensure that your filter pan and components are thoroughly and completely dry before attempting to filter.**

### **Thermostat Calibration**

#### **Thermostat Calibration Check (Standard)**

#### **NOTICE**

**Thermostat calibration requires that the temperature of the appliance be raised above boiling. If you have water in the tank you will need to drain it, dry it and fill it with shortening/oil. Follow the filling instructions in this manual.**

To check the calibration of your appliance, refer to the following procedure.

- a. Place the tip of a digital thermometer probe in the shortening/oil approximately one inch above the temperature sensor.
- b. Perform the Appliance Startup procedure as described in this manual, set the thermostat to 325°F (163 °C) and allow the shortening/oil to come up to temperature. Watch the thermometer closely as the temperature rises.
- c. If the shortening/oil temperature reaches 350°F (167 °) and the burners do not turn off, turn the thermostat down. Keep lowering the thermostat setting until the burners go out.

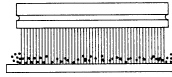

### CAUTION

If the burners do not shut off at the **LOWEST** thermostat setting, the thermostat may be defective. Contact your local service company.

- d. Let the appliance cycle 4 to 6 times before checking the temperature. Compare the thermometer temperature against the thermostat setting. If the values are more than 5°F (3 °C) apart, calibrate the thermostat using procedure in this manual.

### Weekly Cleaning

The appliance should be thoroughly cleaned AT LEAST once a week. This should include a thorough wipe down of the entire appliance with a rag and mild detergent.

### WARNING

**The power supply must be disconnected before cleaning and servicing this appliance!**

### WARNING

**NEVER spray cleaner into the main burners or pilot. This could act as a magnet for dust and other debris, causing it to accumulate and inhibit the proper operation of your appliance.**

### Boil Out Procedure

The appliance should be boiled out AT LEAST once a week to remove food debris and shortening/oil build up. You will need a container large enough to hold 1 ½ times the shortening/oil in the tank. Refer to the following procedure for weekly boil out.

### WARNING

**Completely shut the appliance down when the shortening/oil is being drained and replaced with water. This will prevent the main burners from coming on during the draining and filling procedure.**

### WARNING

**At operating temperatures, the shortening/oil in the appliance is VERY HOT and can cause severe burns. Do not let the hot shortening/oil touch your skin or clothing. ALWAYS wear insulated, oil proof gloves, protective clothing and eyewear when working on a hot appliance.**

- a. Drain the shortening/oil from the appliance and discard or save for reuse. Remove the tube screen. Close the drain valve and fill the tank with warm water and non-caustic detergent. For best results, use Pitco Cleaner. A sample packet is included with your new appliance.
- b. Restart the appliance as described in this manual and set the thermostat to 200°F (93 °C). Bring the water to a slow boil. DO NOT allow the water to boil excessively as this will cause excessive foaming and boil over.
- c. Allow the appliance to soak for 20 minutes to soften shortening/oil deposits. Use the cleaning brush to scrub and remove any residue from the tank, tubes and side walls.
- d. When finished drain the water and wipe the tank dry with a soft clean cloth.
- e. Ensure that the drain valve is closed and replace the tube screen.
- f. You may now refill the tank with shortening/oil per the filling instructions in this manual.

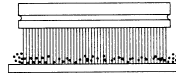

### Ventilation Hood Maintenance

Proper ventilation hood operation is very important for the correct operation of this appliance and the safety of personnel. The ventilation hood should be inspected at the time of installation of this appliance to insure that it will operate properly in conjunction with the appliance. A regular schedule of examination, in accordance with ANSI/NFPA 96 latest edition and/or local codes must be followed.

**To ensure peak performance and efficiency you must ensure proper operation of your appliance. It is recommended that you follow the operation instructions in this manual. Contact a qualified, local service representative to perform maintenance and repairs.**



# TROUBLE SHOOTING

Refer to this section to correct common problems that may be encountered during the course of normal operation. If applicable, a schematic is provided behind the panel containing the electrical components.

