

This Owner's Manual is provided and hosted by [Appliance Factory Parts](#).



PITCO SRTE14S Owner's Manual

[Shop genuine replacement parts for PITCO SRTE14S](#)



[Find Your PITCO Water Cooler Parts - Select From 4 Models](#)

----- Manual continues below -----



IMPORTANT FOR FUTURE REFERENCE
Please complete this information and retain this manual for the life of the equipment:

Model #: _____
Serial #: _____
Date Purchased: _____

ENGLISH

Installation & Operation Manual

Model SRTE

Floor Model Electric Rethermalizer

Built after 8/2005



L20-292, rev. 0 (1/06)

TO THE PURCHASER, OWNER AND STORE MANAGER

Please review these warnings prior to posting them in a prominent location for reference.

WARNING

DO NOT store or use gasoline or other flammable vapors and liquids in the vicinity of this or any other appliance.

WARNING

Improper installation, alteration, service or maintenance can cause property damage, injury or death. Read the installation, operating and maintenance instructions thoroughly before installing or servicing this appliance.

WARNING

Installation, maintenance and repairs should be performed by a Pitco Authorized Service and Parts (ASAP) company technician or other qualified personnel. Installation, maintenance or repairs by an unauthorized and unqualified personnel will void the warranty.

WARNING

Installation and all connections must be made according to national and local regulations and codes in force.

WARNING

A country approved all pole circuit breaker with a minimum open contact gap of 3mm must be used for proper installation. (CE countries)

WARNING

During the warranty period if a customer elects to use a non-original part or modifies an original part purchased from Pitco and/or its Authorized Service and Parts (ASAP) companies, this warranty will be void. In addition, Pitco and its affiliates will not be liable for any claims, damages or expenses incurred by the customer which arises directly or indirectly, in whole or in part, due to the installation of any modified part and/or received from an unauthorized service center.

WARNING

This appliance, when installed, must be electrically grounded in accordance with local codes, or in the absence of local codes, with the National Electrical Code, ANSI/NFPA 70, or the Canadian Electrical Code, CSA C22.2, as applicable.

WARNING

Adequate means must be provided to LIMIT the movement of this appliance without depending on the electrical cord connection. Single appliances equipped with legs must be stabilized by installing anchor straps. All appliances equipped with casters must be stabilized by installing restraining chains.

WARNING

DO NOT alter or remove structural material on the appliance to accommodate placement under a ventilation hood.

WARNING

This appliance is intended for professional use only and should be operated by fully trained and qualified personnel.

WARNING

If the supplied power cord is damaged, it must be replaced by a Pitco Authorized Service and Parts (ASAP) company technician, or a similarly qualified person in order to avoid a hazard.

WARNING

The power supply must be disconnected before servicing, maintaining or cleaning this appliance.

WARNING

The appliance is NOT jet stream approved. DO NOT clean the appliance with a water jet.

WARNING

DO NOT attempt to move this appliance or transfer hot liquids from one container to another when the unit is at operating temperature or filled with hot liquids. Serious personal injury could result if skin comes in contact with the hot surfaces or liquids.

WARNING

DO NOT sit or stand on this appliance. The appliance's front panel, tank, splash back, tank cover, workshelf, drain board is not a step. Serious injury could result from slipping, falling or contact with hot liquids.

WARNING

NEVER use the appliance as a step for cleaning or accessing the ventilation hood. Serious injury could result from slips, trips or from contacting hot liquids.

WARNING

The water level should be maintained at the level line. DO NOT turn the appliance on until the heating elements are fully covered with water at all times. Serious injury could result from hot steam vapors off the heating element.

WARNING

If overflow drain is not equipped or if overflow drain stop is used, do not leave appliance unattended while filling with water. Over filling the appliance can cause serious injuries and damage the equipment.

WARNING

Completely shut the appliance down when the water is being drained from the appliance. This will prevent the appliance from heating up during the draining and filling process. Serious injury and heating element damage can occur.

WARNING

This appliance is intended for indoor use only.

WARNING

DO NOT operate appliance unless all panels and access covers are attached correctly.

WARNING

It is recommended that this appliance be inspected by a qualified service technician for proper performance and operation on a yearly basis.

1. INSTALLATION..... 1

1.1. CHECKING YOUR NEW APPLIANCE..... 1

1.2. INSTALLATION CLEARANCES 2

1.3. LEG/CASTER INSTALLATION AND LEVELING 2

1.4. PLUMBING CONNECTIONS..... 3

1.4.1. WATER INLET CONNECTIONS..... 3

1.4.2. DRAIN CONNECTIONS..... 3

1.5. ELECTRICAL CONNECTIONS 4

1.6. VENTILATION AND FIRE SAFETY SYSTEMS 5

1.7. INSPECTION..... 5

1.8. INITIAL CLEANING 5

2. OPERATION..... 6

2.1. FILLING THE APPLIANCE..... 8

2.1.1. FILLING THE COOKER TANK 8

2.1.2. FILLING THE COOKER TANK WITHOUT THE AUTOMATIC LEVEL SYSTEM..... 8

2.2. APPLIANCE START UP 9

2.3. COOKING..... 9

2.3.1. SIMMER MODE 9

2.3.2. BOIL MODE..... 9

2.3.3. TIMER OPERATION 10

2.3.4. ADDITIONAL CONTROLLER FUNCTIONS 10

2.3.5. COOKING TIPS..... 10

2.4. APPLIANCE SHUTDOWN..... 10

3. PREVENTATIVE MAINTENANCE 11

3.1. DAILY PREVENTATIVE MAINTENANCE 11

3.1.1. APPLIANCE INSPECTION 11

3.1.2. CLEANING THE COOK TANK..... 11

3.1.3. CLEANING THE CABINET 11

TABLE OF CONTENTS



3.2. MONTHLY PREVENTATIVE MAINTENANCE	12
3.2.1. DELIMITING	12
3.3. ANNUAL/PERIODIC PREVENTATIVE MAINTENANCE AND INSPECTION.....	12
3.3.1. HEATING ELEMENT	12
3.3.2. TEMPERATURE PROBE & HIGH LIMIT PROBE	12
3.3.3. CONTROLLER.....	12
3.3.4. CONTROL BOX & ELECTRICAL COMPONENTS.....	12
3.3.5. TANK.....	13
3.3.6. DRAIN SYSTEM	13
4. TROUBLESHOOTING	14
4.1. POWER FAILURE.....	14
4.2. HIGH TEMPERATURE LIMIT	14
4.3. DRAIN VALVE INTERLOCK	14
4.4. TROUBLESHOOTING CHART	15
4.5. CONTROLLER WARNING DISPLAYS.....	15

1. INSTALLATION

1.1. CHECKING YOUR NEW APPLIANCE

Your new Pitco appliance has been carefully packed into one crate. Every effort has been made to ensure that it is delivered to you in perfect condition. As you unpack your new appliance, inspect each of the pieces for damage. If something is damaged, DO NOT sign the bill of lading. Contact the shipper immediately; the shipper is only responsible for 15 days after delivery. Check the packing list enclosed with your appliance to ensure that you have received all the parts to the appliance. If you are missing any parts, contact the dealer from whom the appliance was purchased. As you unpack the appliance and its accessories be careful to keep the weight of the appliance evenly distributed. Refer to the table below to identify which accessories should be included with your appliance.

Locate your Pitco model number and serial number on the inner door of the appliance and find the date purchased. Write this information on the front cover of this manual for future reference.

If you have completed the above steps that are applicable to the appliance you purchased, the appliance is now ready to be installed. Although it may be possible for you to install and set up your new appliance, it is STRONGLY recommended that you have this done by qualified professionals. A qualified professional will ensure that the installation is safe and meets local building and fire codes.

Accessories		
#	Description	SRTE
1	Cleaning brush	Standard
2	Tube Rack	Standard
3	8 Product Vertical Food Rack	Optional
4	8 Product Rack	Optional
5	6 Product Food Rack	Optional
6	Wide Product Suitcase	Optional
7	Narrow Product Suitcase	Optional
8	Tall Wide Product Suitcase	Optional
9	Tall Narrow Product Suitcase	Optional
10	Wide basket	Optional
11	Narrow Basket	Optional
12	8 Product basket	Optional
13	Water Quick Disconnect & Lanyard	Optional
14	1/3 Pan Rails	Optional

WARNING

DO NOT sit or stand on this appliance. The appliance's front panel, tank, splash back, tank cover, workshelf, drain board is not a step. Serious injury could result from slipping, falling or contact with hot liquids.

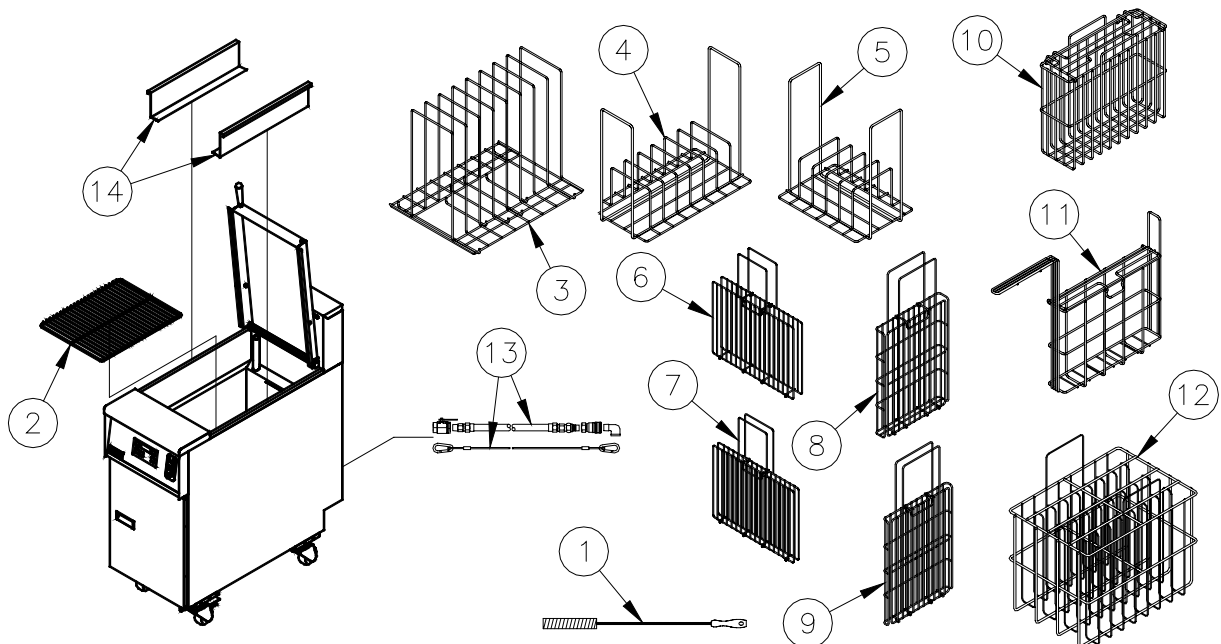

1.2. INSTALLATION CLEARANCES

The clearances shown below are for combustible and non-combustible installations and will allow for safe and proper operation of your appliance.

	Combustible Construction Inches (centimeters)	Non Combustible Construction Inches (centimeters)
Back	6.0" (15.24cm)	0.0" (0.0cm)
Sides	6.0" (15.24cm)	0.0" (0.0cm)
Counter	6.0" (15.24cm)	6.0" (15.24cm)

In addition to the above clearances there must also be at least 16 inches (40.64cm) of aisle space in front of the unit.

WARNING DO NOT obstruct the flow of ventilation, or air openings around the appliance. Adequate clearance around the appliance is necessary for servicing and proper component ventilation. Ensure that you meet the minimum clearance requirements specified in this manual.	WARNING DO NOT install this appliance next to a deep fat fryer. A splash over of water into the hot oil may cause a flash fire.
CAUTION To prevent equipment damage and/or personal injury, do not tilt the appliance onto any two of its casters or legs, or pull the appliance by the splash back.	WARNING This appliance <u>must</u> be installed with the legs or casters provided by the manufacturer.

1.3. LEG/CASTER INSTALLATION AND LEVELING

When you receive your appliance it is completely assembled with the possible exception of the legs (or casters). This appliance must be installed with legs or casters; it cannot be curb mounted. Curb mounting will seriously inhibit this appliance's ability to effect proper component ventilation. The legs/casters must be installed before connecting the appliance to the power supply. The legs provide the necessary height to meet sanitation requirements and assure adequate air supply for the electrical component ventilation. Use the following procedure.

Required tools: 7/16 " wrench and socket and a large pair of water pump pliers.

1. Lay the appliance on its back, being careful not to damage the splash back by pulling on it. Protect the outside of the appliance with cardboard or a drop cloth when laying it down.
2. Attach each leg/caster with the hex head screws and nuts supplied. Each leg/caster requires four ¼-20 x 5/8" hex head screws and nuts. Insure that all screws are tight.
3. Mount the screws from the inside of the appliance with the nut on the outside (bottom) of the appliance. The nuts have lock washers attached to them, therefore it is not necessary to use separate lock washers.

WARNING DO NOT install legs or casters, or perform leveling procedure when appliance is in operation or full of hot liquids. Serious injury could result.
--

4. When all four legs/casters are securely mounted, stand the unit up, being careful not to put too much weight on any one leg. Adjust the height and level the appliance by adjusting the leveling devices (B) with water pump pliers. On casters, loosen 2 screws (A) before leveling, make your height adjustments, then retighten.

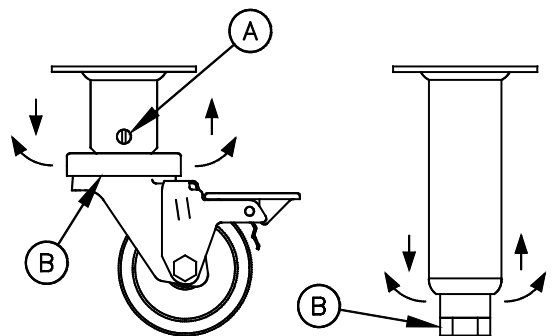

1.5. ELECTRICAL CONNECTIONS

It is advised that this power supply be plugged into a wall receptacle that is controlled by the ventilation control. This will prevent the appliance from being operated without the ventilator on. If your appliance requires an electrical connection, the power requirements are listed below.

Voltage/Phase	KW	Amps
200VAC, single phase	7.4	37
208VAC, single phase	8.0	38
220VAC, single phase	8.9	41
240VAC, single phase	10.7	44
200VAC, three phase	7.4	21
208VAC, three phase	8.0	22
220VAC, three phase	8.9	24
240VAC, three phase	10.7	26
346/200VAC, three phase	7.4	12
380/220VAC, three phase	8.9	14
400/230VAC, three phase	9.8	14
415/240VAC, three phase	10.7	15

<p>WARNING</p> <p>A country approved all pole circuit breaker with a minimum open contact gap of 3mm must be used for proper installation. (CE countries)</p>
<p>CAUTION</p> <p>Connecting the appliance to the wrong power supply may damage the appliance and void the warranty.</p>
<p>WARNING</p> <p>This appliance must be connected to a power supply having the same voltage and phase as specified on the data plate located on the inside of the appliance door.</p>

WARNING

DO NOT attempt to connect the appliance to an electrical supply other than that indicated on the data plate. Electrical connection should be performed by qualified personnel.

WARNING

The appliance must be grounded in accordance with local code; if there is no local code, comply with the NEC and ANSI/NFPA No. 70 latest edition (for US and Canadian installations). In all other cases, refer to local and national codes and regulations. To comply with European requirements, European models are equipped with an equalization-bonding clamp. An equalization bonding lead must be connected to this clamp to provide sufficient protection against potential difference. This clamp, located on the rear of the appliance is marked with the following universal symbol.

WARNING

All copper wiring for this appliance must be made in accordance with the wiring diagram(s) located on the appliance.

WARNING

If this appliance is permanently connected to fixed wiring, it must be connected by means of copper wires having a temperature

WARNING

The electrical connection used by this appliance must comply with local codes. If there are no local codes that apply, refer to the National Electrical Code (NEC), ANSI/NFPA 70 for installation in the US. In Canada, refer to CSA Standard C22.2 and local codes. In all other cases, refer to local and national codes and regulations.

WARNING

This equipment must be installed so that the plug is accessible unless other means for disconnection from the power supply (e.g. a circuit breaker) is provided.

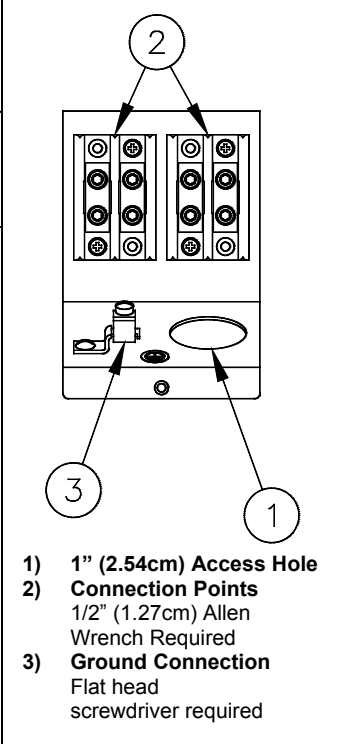
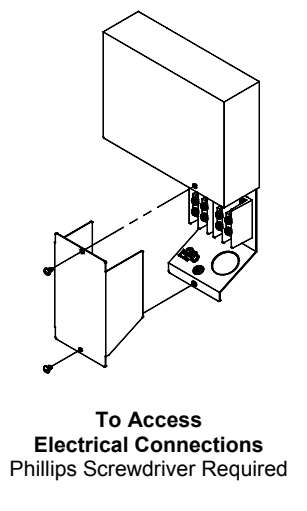

1.6. VENTILATION AND FIRE SAFETY SYSTEMS

Your new appliance must have proper ventilation to function safely and properly. It is very important to install a fire safety system. Your ventilation system should be designed to allow for easy cleaning. Frequent cleaning and proper maintenance of the ventilation system and the appliance will reduce the chances of fire. Ventilation and fire safety systems must comply to local and national codes. Refer to ANSI 83.11 for a list of reference documents that will provide guidance on ventilation and fire safety systems.

1.7. INSPECTION

Before you begin filling and operating the appliance, perform the following visual checks:

- ✓ After the appliance is in its permanent location, check the levelness. Any additional leveling that is necessary can be performed as previously described.
- ✓ Ensure that the probe, heating element and high temperature limit is in place and secure. Check the high limit bulb mounting screws to ensure that they are tight.
- ✓ Review the installation portion of this manual and ensure that all steps have been followed and executed properly.

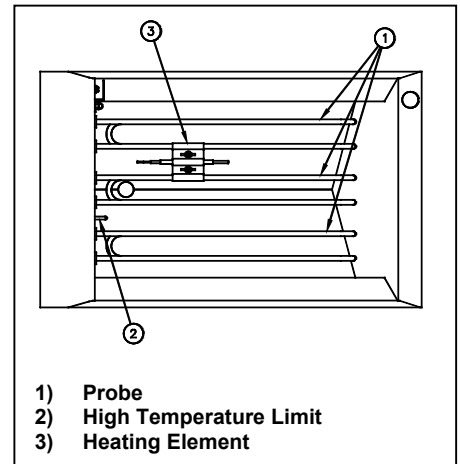

CAUTION

Be careful not to disturb the probe and high temperature limit during operation and cleaning of this appliance.

1.8. INITIAL CLEANING

When your appliance is shipped, many of its parts are covered with a thin coat of oil for protection. Before the appliance is ready for cooking it must be cleaned. This will remove the oil coating and any foreign matter that may have accumulated during storage and shipment. Refer to the following procedure to clean the appliance.

WARNING

Wear protective gloves and clothing when cleaning and draining the appliance and when disposing of water. The water is extremely hot and can cause severe injuries.

CAUTION

DO NOT leave the appliance unattended during cleaning. Never let the water level go below the heating element.

1. Read the "operation" section of this manual prior to filling or operating the appliance.
2. The following steps should be followed using a grease dissolving commercial cleaner.

WARNING

Use a commercial grade cleaner formulated to effectively clean and sanitize food contact surfaces. Read the directions and precautionary statements before use. Particular attention must be paid to the concentration of cleaner and the length of time the cleaner remains on the food contact surfaces.

3. Following the manufacturer's directions, clean the tank interior and all other food contact surfaces.
4. When cleaning is complete, rinse the inside of the tank thoroughly with cool water. Continue to rinse the tank until the cleaner has been completely and thoroughly rinsed from the tank.
5. Using a clean dry cloth, wipe out all of the water.

2. OPERATION

An operator's manual for your appliance's specific control type should be included with this manual. Refer to that manual prior to operating this appliance.

2.1. OPERATIONAL FEATURES

The diagram below outlines some of the key operational components of your appliance. Refer to the following sections of this manual to learn more about these features.

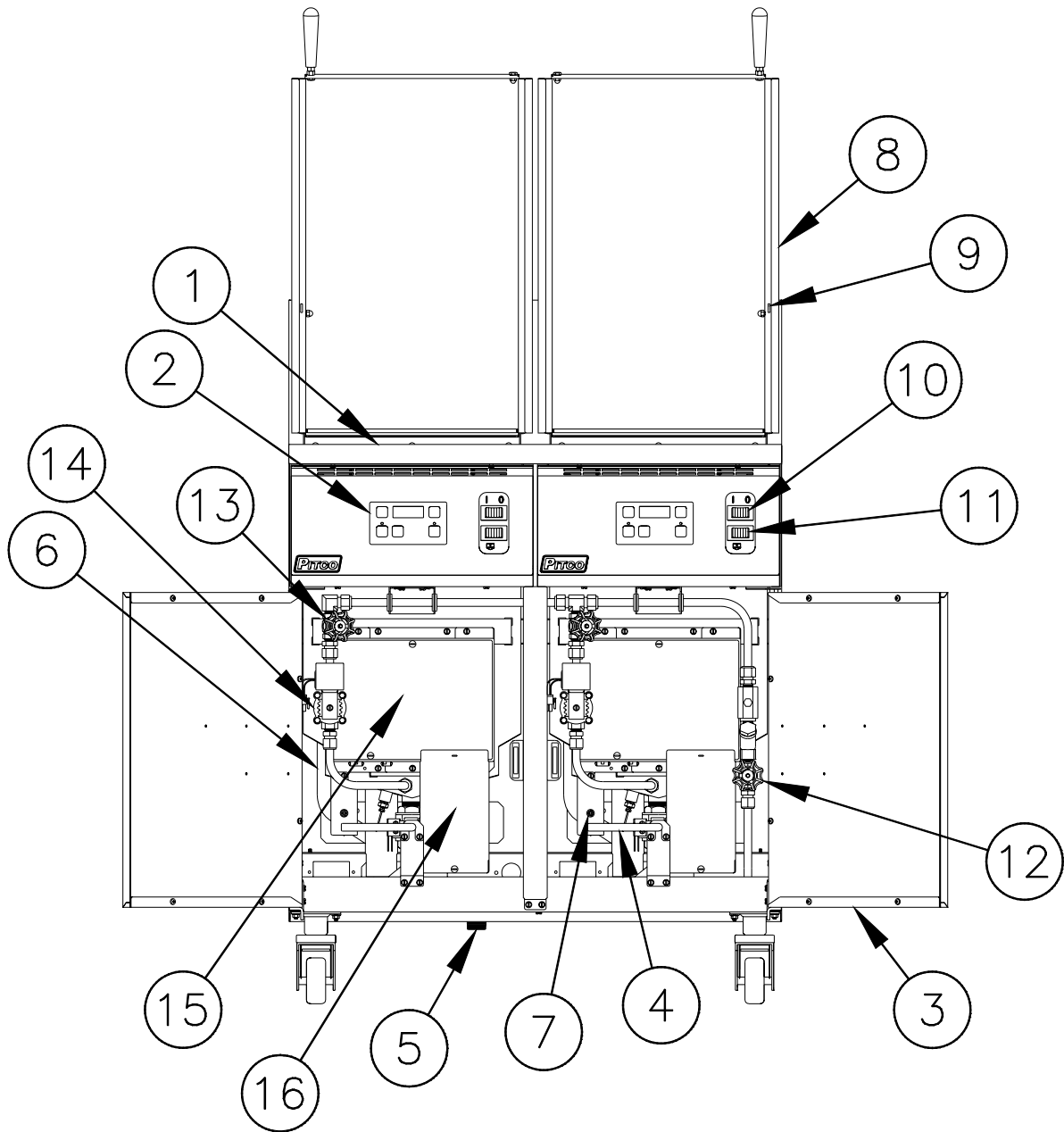

1. **Cook Tank**
2. **Controller (*Not on all Models*)**

Controls the water temperature inside the cook tank.
Optional timers are located on the controller (if equipped).
If the controller has an ON/OFF button, it will be used to turn ON the controller as well as other features on the appliance.
3. **Door (*Shown Open*)**

Provides access to the drain valve handle, high temperature reset button and gas valve, pilot, burners and shutoff valves.
4. **Drain Valve Handle (*Shown in the closed position*)**

Opens the drain valve so water can be drained from the cook tank.
The drain valve interlock feature will stop the appliance from heating if the drain valve is opened.
5. **Drain Outlet**

Water exits the cook tank through the drain outlet when draining or overflowing.
6. **Overflow Line**

When the cook tank water level reaches the overflow, water will flow unobstructed through the overflow line and eventually exit the appliance through the drain outlet.
7. **High Temperature Reset Button**

This button may need to be pressed in the event that the high temperature limit has tripped.
8. **Tank Cover (*shown in UP position*)**

Keeps heat inside and debris outside of the cook tank.
9. **Tank Cover Latch**

Holds the tank cover in the up position when adding or removing product from the cook tank.
10. **ON/OFF Switch**

Turns the appliance ON and OFF. Some controllers require that they are turned ON by another button after the ON/OFF switch is in the ON position.
11. **Fill Bypass Switch**

When this switch is held down the cook tank will fill with water regardless of the water level.
12. **Main Water Shutoff Valve**

Shuts off the water supply to all tanks inside the cabinet.
13. **Tank Water Shutoff Valve**

Shuts off the water supply to the closest tank.
14. **Solenoid Water Valve**

Turns the supply of water to the tank ON and OFF.
This valve is controller by the water level sensors inside the tank.
Valve can also be controlled by the fill bypass switch.
15. **Electrical Control Box**

DANGER: High voltage present. Do NOT open.
Electrical components that control the heating elements are located inside this box.
16. **Entrance Box**

DANGER: High voltage present. Do NOT open.
The main power for the appliance is connected inside this box.

2.2. FILLING THE APPLIANCE

2.2.1. FILLING THE COOKER TANK

It is recommended that the cooker tank is filled with hot water. This will greatly decrease the time it takes for the appliance to reach operating temperature. Refer to the following procedure to fill the cook tank prior to operation.

CAUTION
This appliance is not designed for cooking with oil. Fill with potable water only.

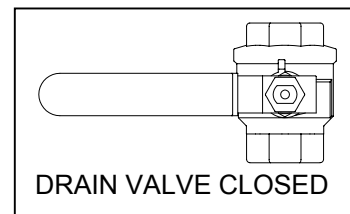

1. Ensure that the drain valve is closed.
2. Fill the tank with water until the water reaches the water level line(s).
3. This appliance is equipped with an automatic water level maintaining system. To fill the tank with water, Press the unit's I/O (ON/OFF) switch to the I (ON) position. This will cause the tank to fill with water. The tank will continue to fill until the water level reaches the level sensors. When both of the active water level sensors are covered the solenoid valve will close stopping the flow of water. During normal operation the automatic fill system will maintain the water level at the proper height.

Tank Capacity	
Model	Capacity
SRTE	17-1/2 Gal. (66.2 Liters)

NOTE: If the water control system turns on while the main burners are running, the main burners will turn off. This is Normal and will not affect the operation of the appliance. When the tank refills to the high level probe, the main burners will relight.

2.2.2. FILLING THE COOKER TANK WITHOUT THE AUTOMATIC LEVEL SYSTEM

Although the water fill system is completely automatic, the tank can be filled without putting the appliance into full operational mode. To fill the tank without operating the appliance press the rocker switch to the symbol. Continue to hold down the switch until the appliance is completely filled.

WARNING
Water must completely cover the heating elements at all times while appliance is on.

2.3. APPLIANCE START UP

Refer to the following procedure to start the appliance prior to operation.

1. Ensure that the drain valve is closed.
2. Fill the cook tank with water. (See section 2.1 “Filling the Appliance”)
3. Turn the I/O (ON/OFF) switch to the I (ON) position.

WARNING

NEVER operate the appliance with an empty cook tank. It may void the warranty. Adding water after the elements have been heated may cause injuries from hot splattering liquids and steam.

4. The controller may need to be turned on. Press the * button to turn the controller on.

**The specified button may appear slightly different than shown. Refer to the operator’s manual for your appliance’s specific control type to determine the exact appearance of each button and display.*

5. The appliance is now on and heating the water in the cook tank.

WARNING

Water must completely cover the heating elements at all times while appliance is on.

2.4. COOKING

It is important to keep the cook tank full of water to minimize the chance of boiling the appliance dry and to keep the water at a level that will provide optimum cooking performance. To ensure the quality of the food you cook in this appliance, follow the preparation instructions from the food manufacturer.

WARNING

Dry fired elements are extremely hot, will shorten its service life and may void your warranty.

Maximum Recommended Product Capacity (after 195°F preheat)
2160 in³ Total (12x 180 in³ bags or equivalent) per tank

2.4.1. SIMMER MODE

Simmer mode maintains the water temperature to just below boiling. This mode is used to reheat food or as a “stand by” mode. When the appliance is turned on, it will be in simmer mode.

2.4.2. BOIL MODE

Boil mode consistently heats the water so that the water will boil. Use of this mode is not recommended for your appliance. Not all control types include boil mode.

2.4.3. TIMER OPERATION

Not all control types include timers. Timers provide accurate cook times for multiple product quantities and types. Refer to the operator's manual for your appliance's specific control type to determine how to set the cook timers if equipped.

To start a timer: Press the appropriate timer button.

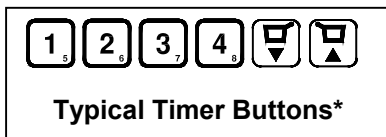

**Timer buttons may appear slightly different than shown. Refer to the operator's manual for your appliance's specific control type to determine the exact appearance of each timer button.*

2.4.4. ADDITIONAL CONTROLLER FUNCTIONS

Some controllers have additional functions not described in this manual. If your appliance's controller has additional functions, refer to the controller's operation manual to access these functions.

2.4.5. COOKING TIPS

- ✓ Always follow the food manufacturer's directions and only use vacuum-sealed products in this appliance.
- ✓ Some products can be reheated and held at the same temperature. If this is the case, the product may be held in this appliance while still in its vacuum-sealed bag. No separate holding device required.
- ✓ Product bag size can be important in reaching the shortest retherm times. Thin bags typically retherm faster than thicker ones.
- ✓ Always allow a gap between product bags. This will allow the hot water to circulate around the entire surface of the product bag, creating good heat transfer and ultimately shorter retherm times.
- ✓ Do NOT retherm in boiling water. Boiling water increases your energy and water consumption and furthermore this appliance is NOT recommended for boiling.
- ✓ Always follow proper food safety. Refer to FDA and the food manufacturer's guidelines for proper handling of the vacuum-sealed product.

Product	Appliance Temperature	
	140F	200F
Frozen	40 min.	9-10 min.
Thawed	30 min.	7-8 min.

This table is for reference only. Please refer to the product manufacturer's specifications to determine exact cook times.

2.5. APPLIANCE SHUTDOWN

Refer to the following procedure to shutdown the appliance.

1. If the appliance is equipped with a controller it should be turned OFF. Refer to the operator's manual for your appliance's specific control type to determine how to do this.
2. If the appliance is equipped with a I/O (ON/OFF) switch, turn it to the 0 (OFF) position.

3. PREVENTATIVE MAINTENANCE

3.1. DAILY PREVENTATIVE MAINTENANCE

Performing the preventative maintenance steps below on a daily basis will keep your equipment safe and at peak performance. During the cooking process, starch build up will form on the temperature probes, tank and heating element. It may be necessary to clean these components more than once a day.

WARNING

The power supply must be disconnected before cleaning and servicing this appliance!

3.1.1. APPLIANCE INSPECTION

- ✓ Check that the high temperature limit, temperature probe and elements are in the correct position and secured in place.
- ✓ Check that wires and cords are not frayed or loose in and out of the cabinet.
- ✓ Check around the appliance for loose parts or accessories that need to be secured or other foreign items (ex: Aerosol cans) that should be removed from the area.
- ✓ Check for water leaks around the drain lines and water supply in and out of the cabinet and around the appliance.

WARNING

Wear protective gloves and clothing when cleaning and draining the appliance and when disposing of water. The water is extremely hot and can cause severe injuries.

3.1.2. CLEANING THE COOK TANK

1. Turn the appliance off.

WARNING

Read the operation section of this manual prior to filling or operating the appliance.

2. Scrub the tank, basket hanger, baskets, heating element and temperature probe using a Scotchbrite™ or other abrasive pad with a commercial type cleaner specifically designed for cleaning and sanitizing food contact surfaces. Follow the directions and familiarize yourself with the safe use of this cleaner prior to using it to clean the appliance. Care must be taken to remove all the foreign material on the tank and on components in the tank.

WARNING

DO NOT leave the appliance unattended during cleaning.

3. When cleaning is complete, rinse the inside of the tank and its components thoroughly with cool water. Continue to rinse at least twice or until the cleaner has been completely and thoroughly rinsed from the tank.

3.1.3. CLEANING THE CABINET

1. The inside of the cabinet should be cleaned with a clean dry cloth removing oil, dust, dirt and cooking debris on all accessible surfaces and components.
2. The outside of the cabinet should be cleaned with a wetted cloth and mild detergent to remove oil, dust, dirt and debris. Be careful not to introduce the detergent into the tank and food zone regions of the appliance.

3.2. MONTHLY PREVENTATIVE MAINTENANCE

Water can leave mineral deposits inside the tank. Performing the monthly preventative maintenance steps below will keep your equipment safe and at peak performance. It may be necessary to clean these components more than once a month.

3.2.1. DELIMING

1. Read the “operation” section of this manual prior to filling or operating the appliance.
2. Following the manufacturer’s deliming instructions, remove deposits from the tank’s interior.
3. When cleaning is complete, rinse the inside of the tank and its components thoroughly with cool water. Continue to rinse at least twice or until the cleaner has been completely and thoroughly rinsed from the tank.
4. Using a clean dry cloth, wipe out all of the water.

3.3. ANNUAL/PERIODIC PREVENTATIVE MAINTENANCE AND INSPECTION

This section should ONLY be performed by a qualified service technician as part of a regular kitchen maintenance program. This inspection should take place a minimum of once a year by an Authorized Service Technician recommended by Pitco. It may be necessary perform this inspection more than once a year.

WARNING
The power supply must be disconnected before cleaning and servicing this appliance!

3.3.1. HEATING ELEMENT

- ✓ Check if the element is mechanically strong and in good condition. Look for scale build up and inspect for signs of repeated dry firing.
- ✓ Verify element wires are in good working condition. Look for damage to wires or frayed insulation. Check that the insulation is dry.
- ✓ Verify that bulkhead connections/nut is tight and leak free. Look for water stains and wet surfaces.
- ✓ Verify amp-draw is within range as compared to the information on the data plate.

3.3.2. TEMPERATURE PROBE & HIGH LIMIT PROBE

- ✓ Verify probes are in good working condition. Check for damage and that the fasteners are tightly secured to the tank.
- ✓ Verify compression fittings are leak free.
- ✓ Check wiring for loose electrical connections.

3.3.3. CONTROLLER

Perform the following inspection if the appliance is equipped with a temperature controller.

- ✓ Verify that the controller is in good mechanical condition. Check all lights, displays and switches to assure that they are working properly. Examine overlay for damage that could allow moisture to enter.
- ✓ Check for loose electrical connections.
- ✓ Verify simmer temperature. Check temperature 1” above controller probe, if necessary check probe resistance.
- ✓ Check drain valve interlock (if provided) to ensure that the appliance stops heating when the drain valve is open.

3.3.4. CONTROL BOX & ELECTRICAL COMPONENTS

- ✓ Verify that heating contactors are in good condition. Check for worn or pitted contacts. Verify that wires are tight and in good condition.
- ✓ Verify that all components (transformer, terminal block, relays, drain switches, etc...) are in good condition. Verify that wires are tight and in good condition.
- ✓ Verify enclosures are free of leaks. Check for water stains and wet surfaces.
- ✓ Verify that the covers and panels are in tact and provide a safe condition. Check for loose parts.
- ✓ Verify power cord is in good condition. Check for frayed or exposed wires. Verify that the insulation is in good condition and the attachment to the appliance is tight.

3.3.5. TANK

- ✓ Verify that the tank is in good condition. Check for scale build up and inspect for signs of corrosion. Verify that tank is leak free. Check drain overflow (if equipped) for scale build up and debris blockage.

3.3.6. DRAIN SYSTEM

- ✓ Verify that drain valve is in good condition. Check for leaks in the seal area and fitting region.
- ✓ Verify that drain lines are leak free, kink free and in good condition. Check for scale build up and debris blockage. Verify that the clamps and connections are securely tightened.

4. TROUBLESHOOTING

4.1. POWER FAILURE

If electric power is removed for any reason, the appliance will shut down. To restart the appliance, follow the appliance start up procedure in section 2.2.

CAUTION
DO NOT attempt to operate this appliance during a power outage.

4.2. HIGH TEMPERATURE LIMIT

This appliance is equipped with a high temperature limit switch. The high temperature limit switch will stop the appliance from functioning if the internal cook tank reaches an unsafe temperature. In the event that the high temperature limit has tripped, Please refer to the following procedure to reset the switch.

1. Turn the appliance off.
2. Allow the appliance ample time to cool to room temperature.
3. Add water to the cook tank as needed.
4. Press the high temperature reset button if equipped.
5. The high limit switch is now reset and the appliance is ready for start up.

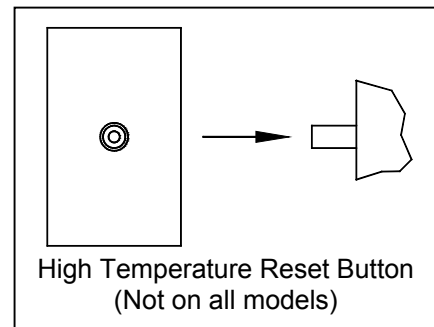

WARNING
DO NOT add water to the tank until it has been given ample time to cool down. Failure to do so may result in damage to the appliance and/or injury to the operator.

4.3. DRAIN VALVE INTERLOCK

If your appliance is equipped with a drain valve interlock circuit, the appliance will stop heating if the tank drain valve is opened. In some cases the appliance will turn off. Refer to the following procedure to resume operation after the drain valve interlock is tripped.

1. Turn the appliance OFF (if not already OFF).
2. Close the tank drain valve and fill the tank with water.
3. Turn the appliance ON.

4.4. TROUBLESHOOTING CHART

Problem	Probable Causes	Corrective Actions
Controller does not activate.	No power to appliance.	Check main building power supply.
	Circuit Breaker tripped.	Reset circuit breaker.
	I/O Switch in 0 position.	Flip I/O switch to I position and turn on controller.
	Controller not turned on.	Turn on controller.
	Power Cord loose or not connected.	Connect power cord.
Autofill does not add water.	Water not turned on.	Turn on water.
	Lower water level sensor is wet.	Dry off sensor.
Autofill does not shut off when full.	Dirty upper water level sensor.	Clean upper water level sensor.
	Insufficient mineral content in water.	Add 1/8 cup baking soda to cook tank.
Controller displays that it is heating but water will not heat.	Autofill system has cutoff heat.	Allow Autofill system to fill tank and restore heat.
	High temperature limit has tripped	Allow appliance to cool and reset High temperature limit.

4.5. CONTROLLER WARNING DISPLAYS

If your appliance is equipped with a temperature controller it may display the following warnings on its display.

Display	Problem	Action
	Water temperature is low.	Wait for appliance to heat up.
	Incorrect probe reading.	Contact Authorized Service Company.
	Water level is low.	Turn off appliance. Allow ample time for appliance to cool before filling with water and turning on.
	Incorrect probe reading.	Contact Authorized Service Company.
	Drain valve is open while controller is on.	Turn off appliance. Close drain valve before turning appliance back on.



In the event of problems with or questions about your order, please contact the Pitco Frialator factory at:
(800) 258-3708 US and Canada only or
(603) 225-6684 World Wide
Website Address: www.pitco.com

In the event of problems with or questions about your equipment, please contact the Pitco Frialator Authorized Service and Parts representative (ASAP) covering your area, or contact Pitco at the numbers listed to the left.

MAILING ADDRESS – P.O. BOX 501, CONCORD, NH 03302-0501
SHIPPING ADDRESS – 10 FERRY ST., CONCORD, NH 03301