

This Owner's Manual is provided and hosted by [Appliance Factory Parts](#).



LG LRDN22734TT Owner's Manual

[Shop genuine replacement parts for LG LRDN22734TT](#)



Appliance Factory Parts
<http://www.appliancefactoryparts.com>

[Find Your LG Refrigerator Parts - Select From 834 Models](#)

----- Manual continues below -----



REFRIGERATOR SERVICE MANUAL

CAUTION
BEFORE SERVICING THE UNIT,
READ THE SAFETY PRECAUTIONS IN THIS MANUAL.

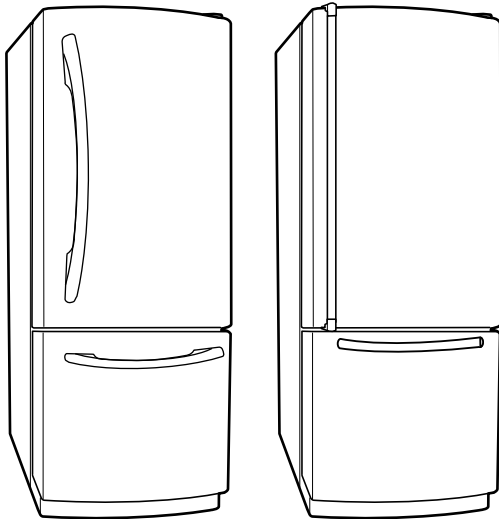

Models:
LRDN22734SB
LRDN22734ST
LRDN22734TT
LRDN22734WW

CONTENTS

SAFETY PRECAUTIONS	2
SPECIFICATIONS.....	3
PARTS IDENTIFICATION	4-7
DISASSEMBLY.....	8-9
DOOR.....	8
DOOR SWITCH.....	8
FAN AND FAN MOTOR.....	9
DEFROST CONTROL ASSEMBLY.....	9
LAMP.....	9
CONTROL BOX-REFRIGERATOR.....	9
MULTI DUCT.....	9
ADJUSTMENT.....	10-11
COMPRESSOR.....	10
PTC-STARTER.....	10
OLP (OVERLOAD PROTECTOR).....	11
TO REMOVE THE COVER PTC.....	11
CIRCUIT DIAGRAM.....	12-13
TROUBLESHOOTING.....	14-19
COMPRESSOR AND ELECTRIC COMPONENTS	14
PTC AND OLP.....	15
OTHER ELECTRICAL COMPONENTS	16
SERVICE DIAGNOSIS CHART.....	17
REFRIGERATION CYCLE.....	18-19
OPERATION PRINCIPLE & REPAIR METHOD OF ICEMAKER	20-23
DESCRIPTION OF FUNCTION & CIRCUIT OF MICOM (BEST, DISPENSER)	24-44
DESCRIPTION OF FUNCTION & CIRCUIT OF MICOM (GOOD, BETTER)	45-64
REFRIGERATOR EXPLODED VIEW & SERVICE PARTS LIST.....	65-102

SAFETY PRECAUTIONS

Please read the following instructions before servicing your refrigerator.

1. Check the refrigerator for electrical faults.
2. To prevent electric shock, unplug before servicing.
3. Always check line voltage and amperage.
4. Use standard electrical components.
5. Don't touch metal products in the freezer with wet hands. This may cause frostbite or cause your skin to freeze and stick to the surfaces inside the freezer.
6. Prevent water from flowing onto electric elements in the mechanical parts.
7. Close the top door before opening the bottom door. Otherwise, you might hit your head when you stand up.
8. When tilting the refrigerator, remove any materials on the refrigerator, especially the glass shelves and stored foods.
9. When servicing the evaporator, wear cotton gloves. This is to prevent injuries from the sharp evaporator fins.
10. Disassembly, repair, and servicing the sealed refrigeration system should be performed only by qualified and certified personnel. Refrigerant should not be vented into the atmosphere; proper recovery equipment should be used.

1. SPECIFICATIONS

20 cu. ft. / 22 cu. ft.

ITEMS	SPECIFICATIONS	ITEMS	SPECIFICATIONS	
DOOR DESIGN	Side Rounded	VEGETABLE TRAY	Opaque Drawer Type	
DIMENSIONS (inches)	29 7/8 x 31 3/4 x 67 7/8 (WxDxH) 20cu.ft	COMPRESSOR	PTC Starting Type	
	32 7/8 x 31 3/4 x 69 1/2 (WxDxH) 22cu.ft Dispenser	EVAPORATOR	Fin Tube Type	
	32 7/8 x 31 3/4 x 68 1/2 (WxDxH) 22cu.ft	CONDENSER	Wire Condenser	
NET WEIGHT (pounds)	238.4 (20cu.ft)	REFRIGERANT	R-134a (115 g)	
	246.9 (22cu.ft)	LUBRICATING OIL	Freol @ 10G (310 cc)	
COOLING SYSTEM	Fan Cooling	DEFROSTING DEVICE	SHEATH HEATER	
TEMPERATURE CONTROL	Micom Control	LAMP	REFRIGERATOR	60 W (2EA)
DEFROSTING SYSTEM	Full Automatic Heater Defrost		FREEZER	60 W (2EA)
DOOR FINISH	Embossed Metal, VCM, Stainless			
HANDLE TYPE	Bar, Al			
INNER CASE	ABS Resin			
INSULATION	Polyurethane Foam			

2. PARTS IDENTIFICATION

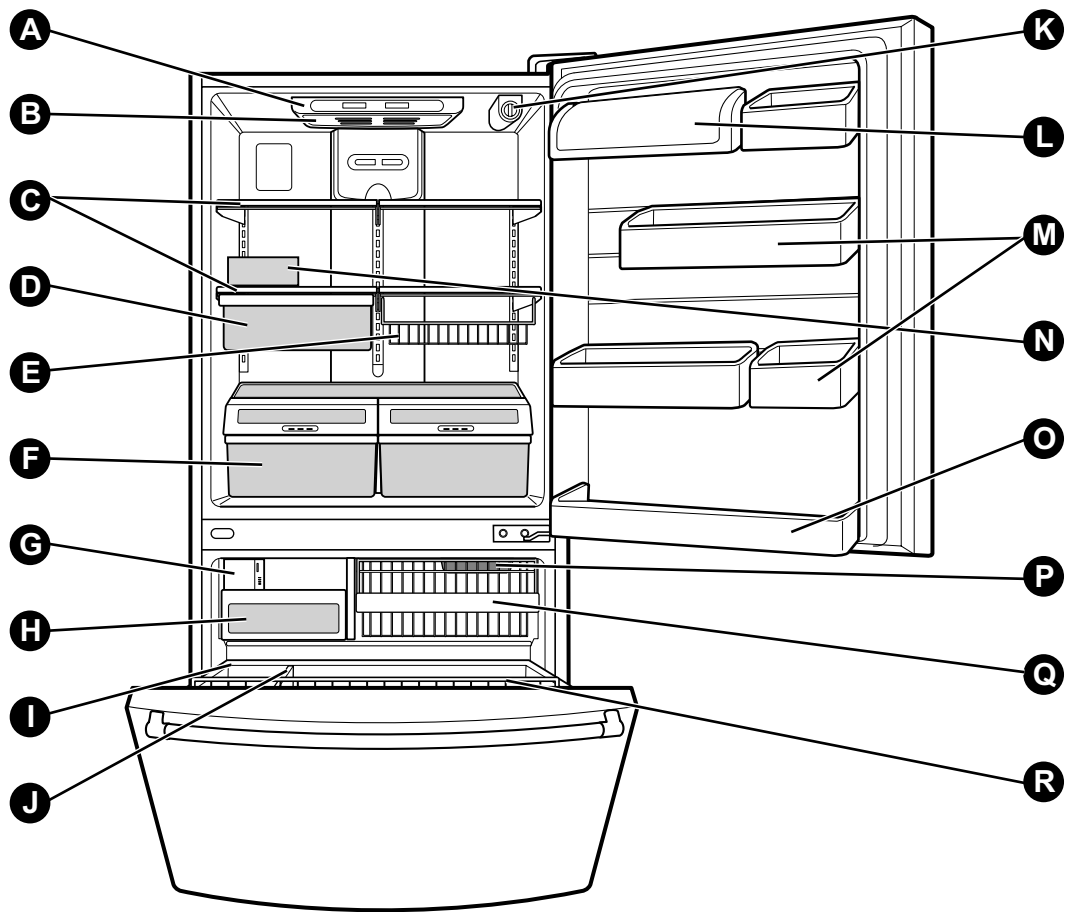

NOTE: This guide covers several different models. The refrigerator you have purchased may have some or all of the items listed below. The locations of the features shown below may not match your model.

A Digital Sensor Control

B Refrigerator Light

C Shelves

D Chef Fresh / Snack Pan*

E Can Dispenser*

F Optibin Crisper
Keeps fruits and vegetable fresh and crisper

G Customcube Icemaker

H Ice Bin

I Durabase

J Divider

K Filter (inside)*

L Dairy Bin

M Design-A-Door

N Egg Box

O Refrigerator Door Rack

P Freezer Light

Q Wire Basket

R Freezer Door Rack (Tilting*)

*on some models

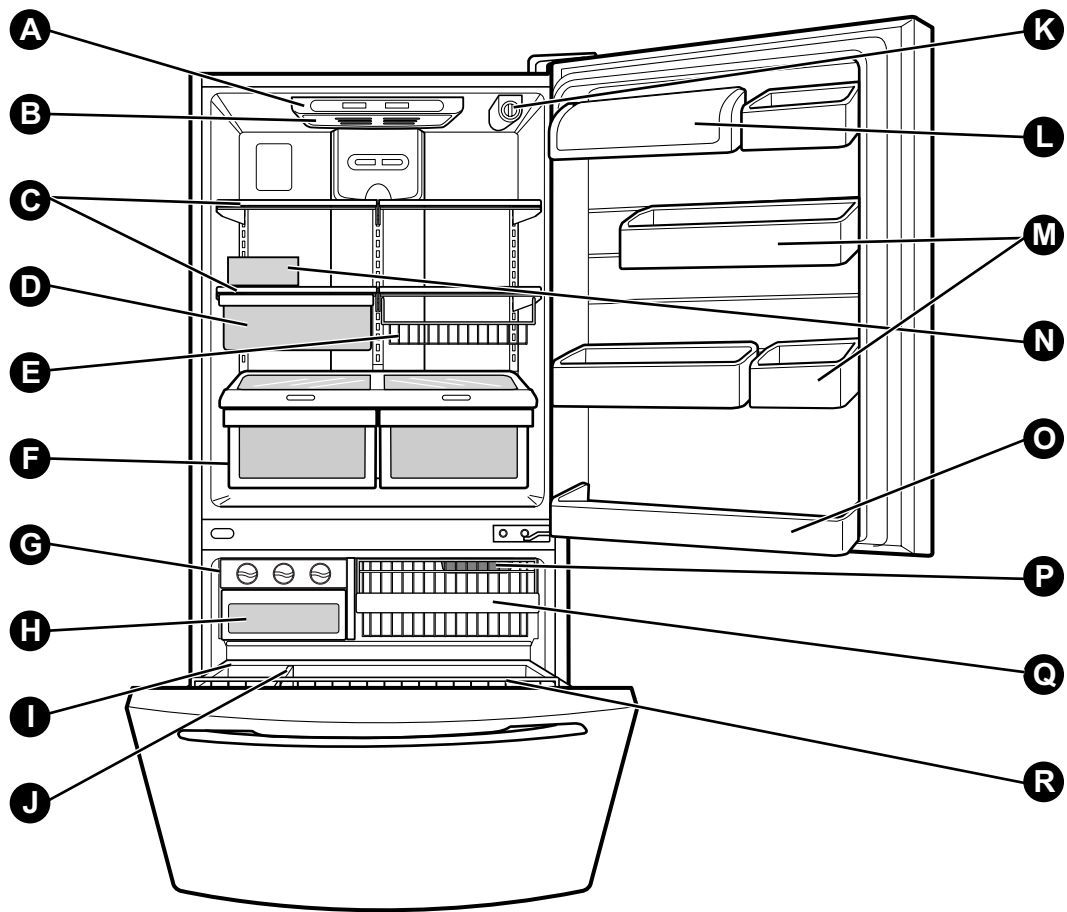

NOTE: This guide covers several different models. The refrigerator you have purchased may have some or all of the items listed below. The locations of the features shown below may not match your model.

A Digital Sensor Control

B Refrigerator Light

C Shelves

D Chef Fresh / Snack Pan*

E Can Dispenser*

F Optibin Crisper
Keeps fruits and vegetable fresh and crisper

G Triple Ice Tray

H Ice Bin

I Durabase

J Divider

K Filter (inside)*

L Dairy Bin

M Design-A-Door

N Egg Box

O Refrigerator Door Rack

P Freezer Light

Q Wire Basket

R Freezer Door Rack (Tilting*)

*on some models

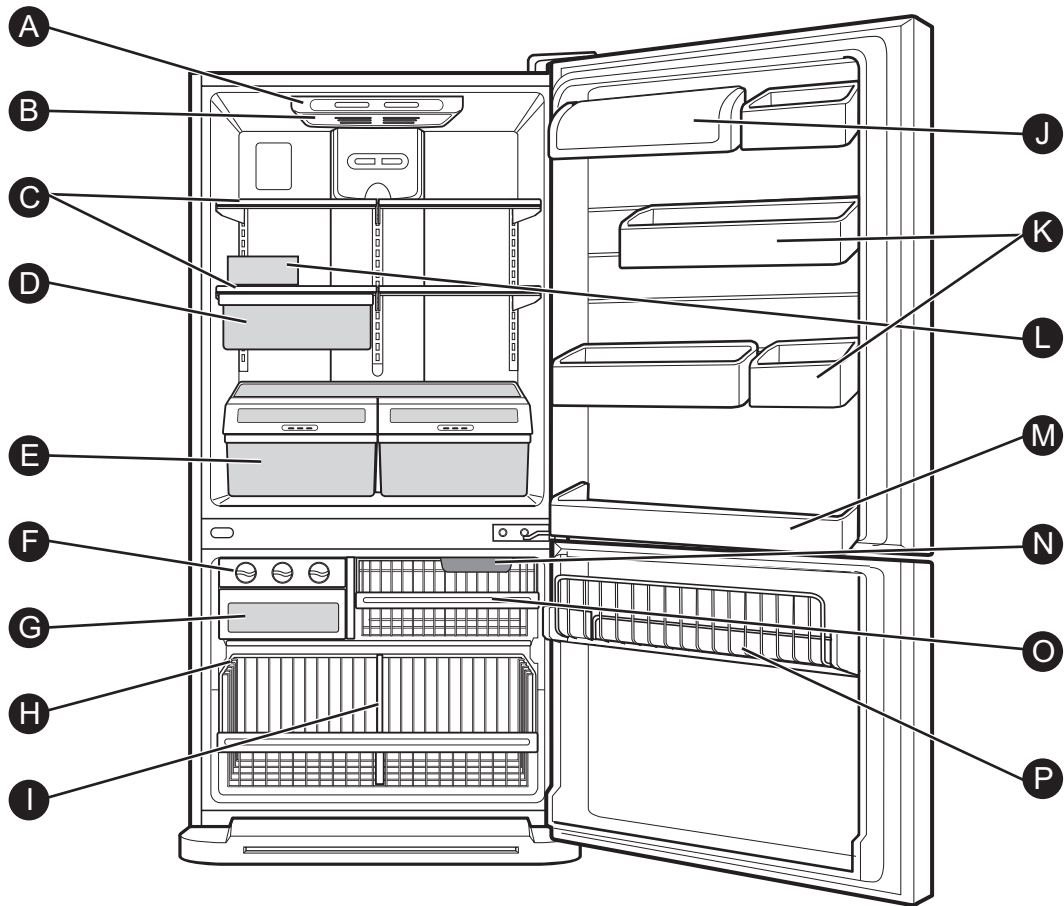

NOTE: This guide covers several different models. The refrigerator you have purchased may have some or all of the items listed below. The locations of the features shown below may not match your model.

- | | |
|---|--------------------------|
| Ⓐ Digital Sensor Control | Ⓘ Divider |
| Ⓑ Refrigerator Light | Ⓝ Dairy Bin |
| Ⓒ Shelves | Ⓚ Design-A-Door |
| Ⓓ Snack Pan | Ⓛ Egg Box |
| Ⓔ Optibin Crisper
Keeps fruits and vegetable fresh and crisp | Ⓜ Refrigerator Door Rack |
| Ⓣ Triple Twist Ice Tray | Ⓝ Freezer Light |
| Ⓝ Ice Bin | Ⓞ Wire Basket |
| Ⓞ Wire Durabase | Ⓟ Freezer Wire Door Rack |

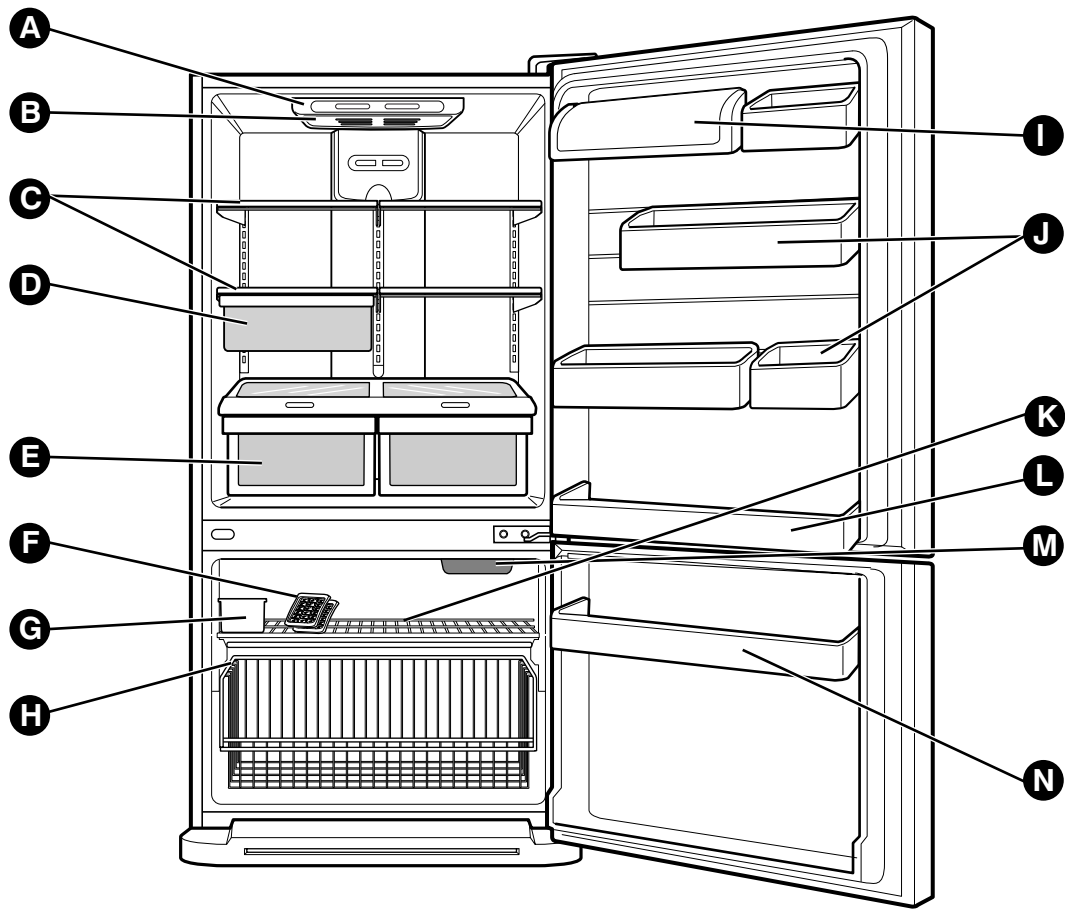

NOTE: This guide covers several different models. The refrigerator you have purchased may have some or all of the items listed below. The locations of the features shown below may not match your model.

- A** Digital Sensor Control
- B** Refrigerator Light
- C** Shelves
- D** Snack Pan
- E** Optibin Crisper
Keeps fruits and vegetable fresh and crisp
- F** Ice Trays
- G** Ice Bin
- H** Wire Durabase
- I** Dairy Bin
- J** Design-A-Door
- K** Wire Freezer Shelf
- L** Refrigerator Door Rack
- M** Freezer Light
- N** Freezer Door Rack

3. DISASSEMBLY

3-1 DOOR

● Refrigerator Door

1. Remove the hinge cover by pulling it upwards.
2. Loosen the hexagonal bolts attaching the upper hinge to the body and lift the freezer door.

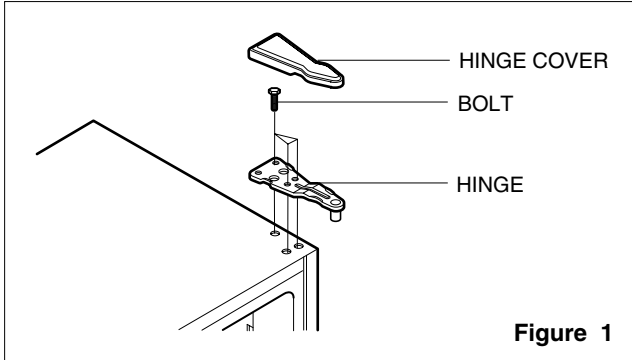

3. Pull out the door gasket to remove from the door foam assembly.

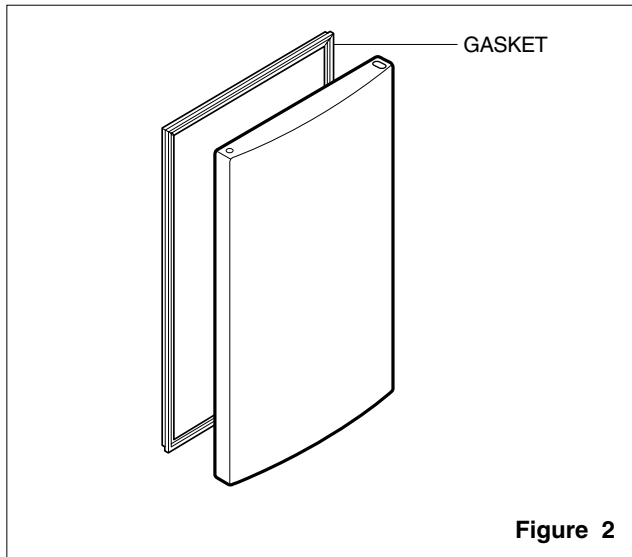

● Freezer Door

1. Loosen the hexagonal bolts attaching the lower hinge to the body to remove the refrigerator door only.

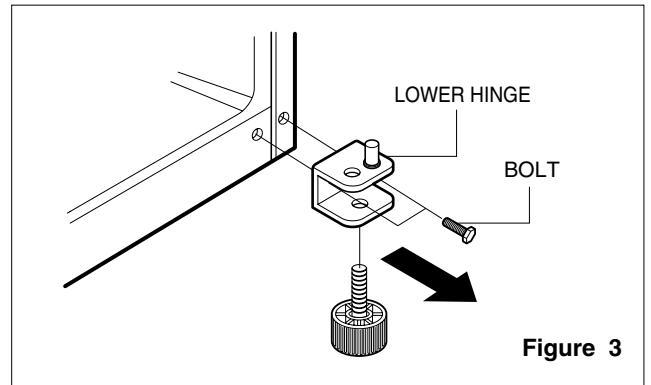

2. Pull out the door gasket to remove from the door foam assembly.

3-2 DOOR SWITCH

1. To remove the door switch, pry it out with a slotted-type driver, as shown in (Figure 4).
2. Disconnect the lead wire from the switch.

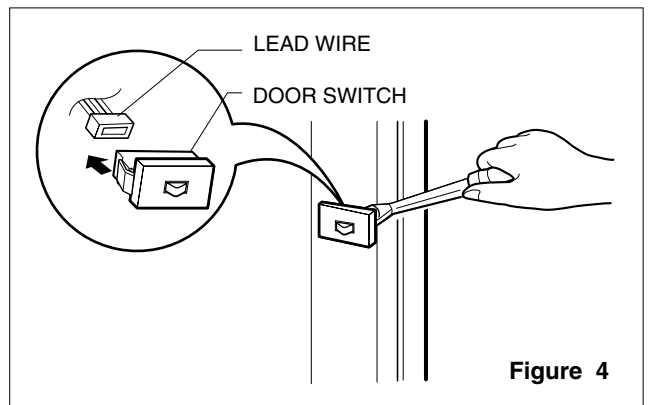

3-3 FAN AND FAN MOTOR

1. Remove the freezer shelf. (If your refrigerator has an icemaker, remove the icemaker first)
2. Remove the grille by pulling it out and by loosening a screw.
3. Remove the Fan Motor assembly by loosening 2 screws and disassemble the shroud.
4. Pull out the fan and separate the Fan Motor and Bracket.

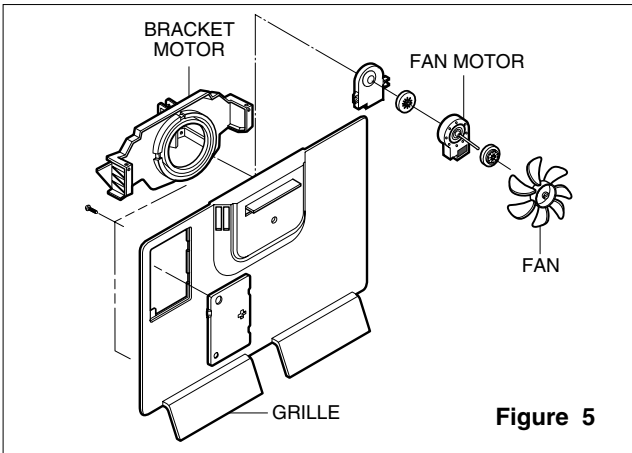

Figure 5

3-4 DEFROST CONTROL ASSEMBLY

Defrost Control assembly consists of Defrost Sensor and FUSE-M.

The Defrost Sensor works to defrost automatically. It is attached to the metal side of the Evaporator and senses its temperature. At 72°C, it turns the Defrost Heater off. Fuse-M is a safety device for preventing over-heating of the Heater when defrosting.

1. Pull out the grille assembly. (Figure 6)
2. Separate the connector with the Defrost Control assembly and replace the Defrost Control assembly after cutting the Tie Wrap. (Figure 7)

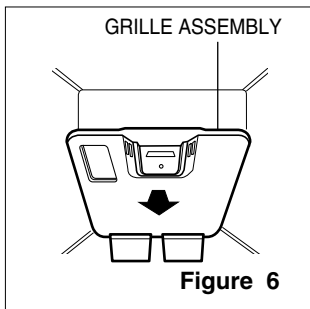

Figure 6

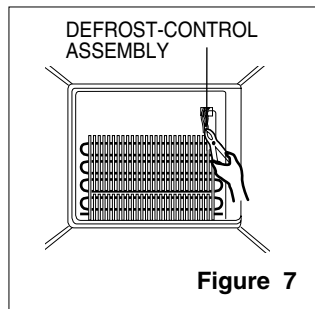

Figure 7

3-5 LAMP

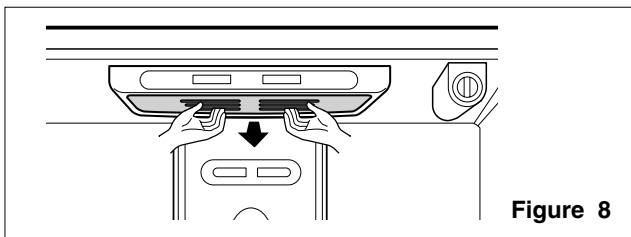

Figure 8

3-5-1 Refrigerator Compartment Lamp

1. Unplug the power cord from the outlet.
2. Remove refrigerator shelves.
3. Release the hooks on both ends of the lamp shield and pull the shield downward to remove it.
4. Turn the lamp counterclockwise.
5. Assemble in reverse order of disassembly. Replacement bulb must be the same specification as the original (Max. 60 W-2EA).

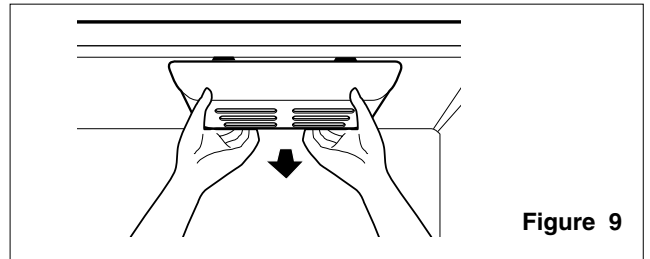

Figure 9

3-5-2 Freezer Compartment Lamp

1. Unplug refrigerator or disconnect power.
2. Reach behind light shield to remove bulb.
3. Replace bulb with a 60-watt appliance bulb.
4. Plug in refrigerator or reconnect power.

3-6 CONTROL BOX-REFRIGERATOR

1. First, remove all shelves in the refrigerator, then remove the Refrigerator control Box by loosening 2 screws.

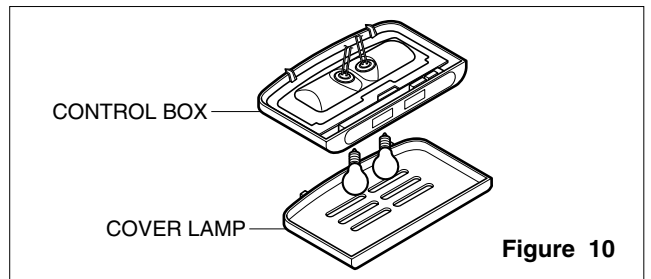

Figure 10

2. Remove the Refrigerator Control Box by pulling it downward.
3. Disconnect the lead wire on the right position and separate the lamp sockets.

3-7 MULTI DUCT

1. Remove an upper and lower Cap by using a flat screwdriver, and loosen 3 screws. (Figure 11)
2. Disconnect the lead wire on the bottom position.

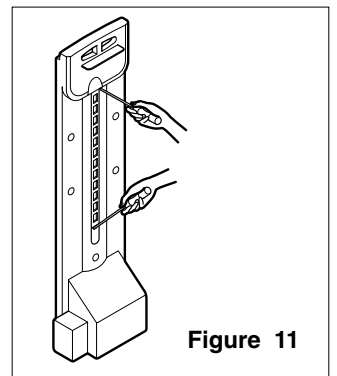

Figure 11

4. ADJUSTMENT

4-1 COMPRESSOR

4-1-1 Role

The compressor intakes low temperature and low pressure gas from the evaporator of the refrigerator and compresses this gas to high-temperature and high-pressure gas. It then delivers the gas to the condenser.

4-1-2 Composition

The compressor includes overload protection. The PTC starter and OLP (overload protector) are attached to the outside of the compressor. Since the compressor is manufactured to tolerances of 1 micron and is hermetically sealed in a dust and moisture-free environment, use extreme caution when repairing it.

4-1-3 Note for Usage

- (1) Be careful not to allow over-voltage and over-current.
- (2) If compressor is dropped or handled carelessly, poor operation and noise may result.
- (3) Use proper electric components appropriate to the Particular Compressor in your product.
- (4) Keep Compressor dry.
If the Compressor gets wet (in the rain or a damp environment) and rust forms in the pin of the Hermetic Terminal, poor operation and contact may result.
- (5) When replacing the Compressor, be careful that dust, humidity, and soldering flux don't contaminate the inside of the compressor. Dust, humidity, and solder flux contaminate the cylinder and may cause noise, improper operation or even cause it to lock up.

4-2 PTC-STARTER

4-2-1 Composition of PTC-Starter

- (1) PTC (Positive Temperature Coefficient) is a no-contact semiconductor starting device which uses ceramic material consisting of BaTiO₃.
- (2) The higher the temperature is, the higher the resistance value. These features are used as a starting device for the Motor.

4-2-2 Role of PTC-Starter

- (1) The PTC is attached to the Sealed Compressor and is used for starting the Motor.
- (2) The compressor is a single-phase induction motor. During the starting operation, the PTC allows current flow to both the start winding and main winding.

4-2-3 PTC-Applied Circuit Diagram

● Starting Method for the Motor

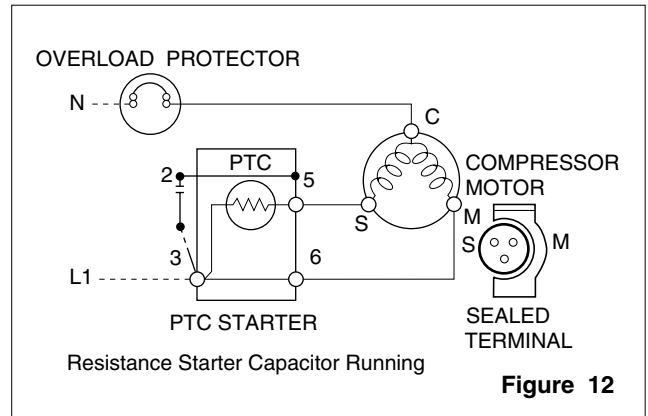

4-2-4 Motor Restarting and PTC Cooling

- (1) It requires approximately 5 minutes for the pressure to equalize before the compressor can restart.
- (2) The PTC device generates heat during operation. Therefore, it must be allowed to cool before the compressor can restart.

4-2-5 Relation of PTC-Starter and OLP

- (1) If the compressor attempts to restart before the PTC device is cooled, the PTC device will allow current to flow only to the main winding.
- (2) The OLP will open because of the over current condition. This same process will continue (3 to 5 times) when the compressor attempts to restart until the PTC device has cooled. The correct OLP must be properly attached to prevent damage to the compressor.

Parts may appear physically identical but could have different electrical ratings. Replace parts by part number and model number. Using an incorrect part could result in damage to the product, fire, injury, or possibly death.

4-2-6 Note for Using the PTC-Starter

- (1) Be careful not to allow over-voltage and over-current.
- (2) Do not drop or handle carelessly.
- (3) Keep away from any liquid.
If liquid such as oil or water enters the PTC, PTC materials may fail due to breakdown of their insulating capabilities.
- (4) If the exterior of the PTC is damaged, the resistance value may be altered. This can cause damage to the compressor and result in a no-start or hard-to-start condition.
- (5) Always use the PTC designed for the compressor and make sure it is properly attached to the compressor. Parts may appear physically identical but could have different electrical ratings. Replace parts by part number and model number. Using an incorrect part could result in damage to the product, fire, injury, or possibly death.

4-3 OLP (OVERLOAD PROTECTOR)

4-3-1 Definition of OLP

- (1) OLP (OVERLOAD PROTECTOR) is attached to the Compressor and protects the Motor by opening the circuit to the Motor if the temperature rises and activating the bimetal spring in the OLP.
- (2) When high current flows to the Compressor motor, the Bimetal works by heating the heater inside the OLP, and the OLP protects the Motor by cutting off the current flowing to the Compressor Motor.

4-3-2 Role of the OLP

- (1) The OLP is attached to the Sealed Compressor used for the Refrigerator. It prevents the Motor Coil from being started in the Compressor.
- (2) For normal operation of the OLP, do not turn the Adjust Screw of the OLP in any way.

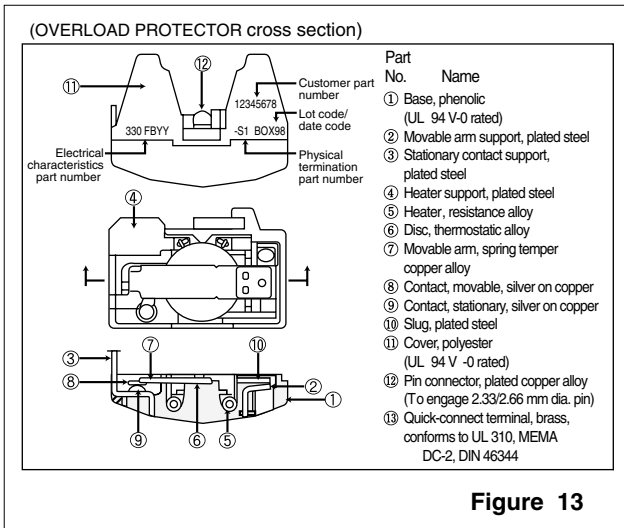

4-4 TO REMOVE THE COVER PTC

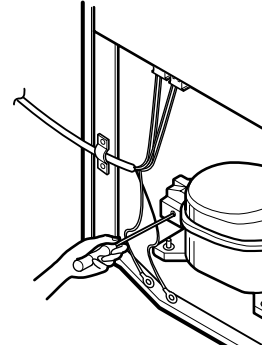

- 1) Remove the Cover Back M/C.
- (2) Remove the screw on Cover PTC.

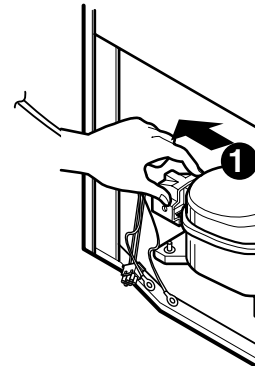

- (3) Remove two Housings on upper part of Cover PTC.
- (4) Take out the cover PTC from upper to lower position like ①.

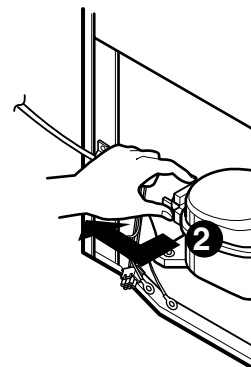

- (5) Turn 45° in the direction of ② and take it out.
- (6) Assembly in reverse order of disassembly.

5. CIRCUIT DIAGRAM

Best / Best dispenser



DIAGRAMA ELECTRICO - CIRCUIT DIAGRAM

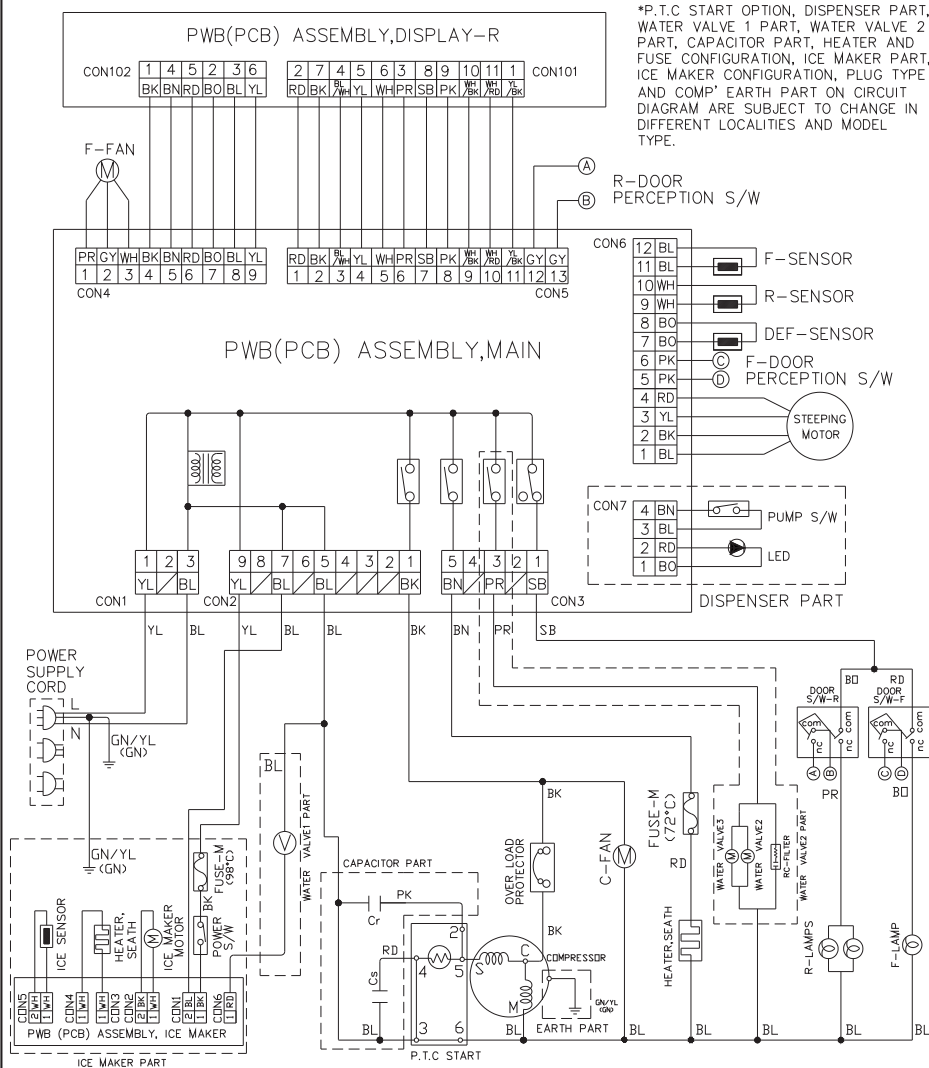

*P.T.C START OPTION, DISPENSER PART, WATER VALVE 1 PART, WATER VALVE 2 PART, CAPACITOR PART, HEATER AND FUSE CONFIGURATION, ICE MAKER PART, ICE MAKER CONFIGURATION, PLUG TYPE AND COMP' EARTH PART ON CIRCUIT DIAGRAM ARE SUBJECT TO CHANGE IN DIFFERENT LOCALITIES AND MODEL TYPE.

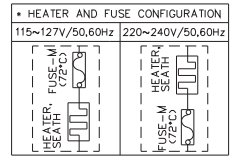
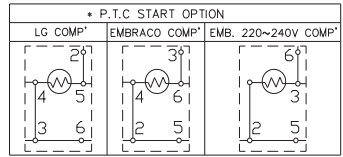
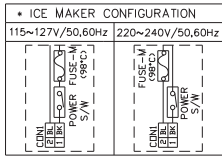

- BK: NEGRO/BLACK BN: CAFE/BROWN RD: ROJO/RED BO: NARANJA/BRIGHT ORANGE
- YL: AMARILLO/YELLOW GN: VERDE/GREEN BL: AZUL/BLUE PR: VIOLETA/PURPLE GY: GRIS/GRAY
- WH: BLANCO/WHITE SB: AZUL CIELO/SKY BLUE PK: ROSA/PINK

Good / Better

DIAGRAMA ELECTRICO - CIRCUIT DIAGRAM

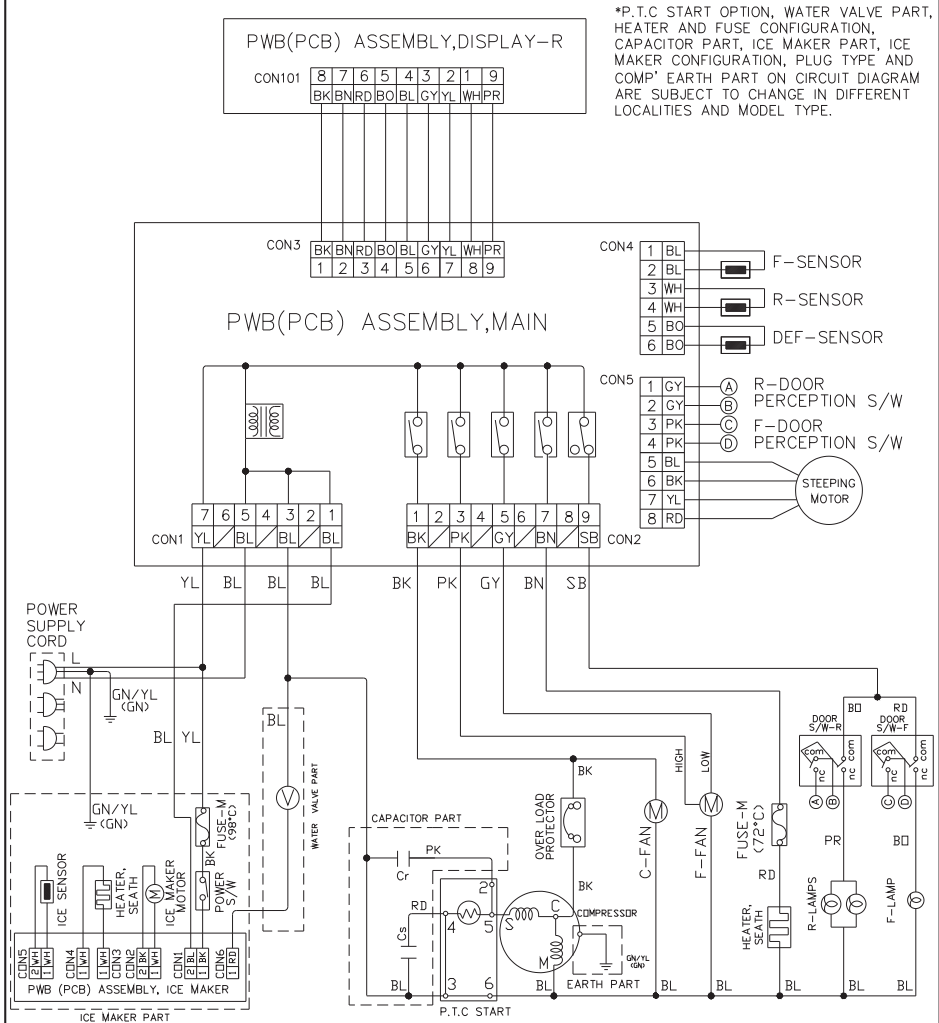

*P.T.C START OPTION, WATER VALVE PART, HEATER AND FUSE CONFIGURATION, CAPACITOR PART, ICE MAKER PART, ICE MAKER CONFIGURATION, PLUG TYPE AND COMP' EARTH PART ON CIRCUIT DIAGRAM ARE SUBJECT TO CHANGE IN DIFFERENT LOCALITIES AND MODEL TYPE.

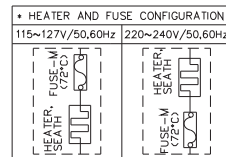
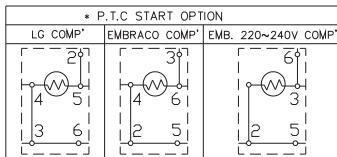
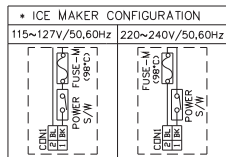

- BK: NEGRO/BLACK BN: CAFE/BROWN RD: ROJO/RED BO: NARANJA/BRIGHT ORANGE
- YL: AMARILLO/YELLOW GN: VERDE/GREEN BL: AZUL/BLUE PR: VIOLETA/PURPLE GY: GRIS/GRAY
- WH: BLANCO/WHITE SB: AZUL CIELO/SKY BLUE PK: ROSA/PINK

6. TROUBLESHOOTING

6-1 COMPRESSOR AND ELECTRIC COMPONENTS

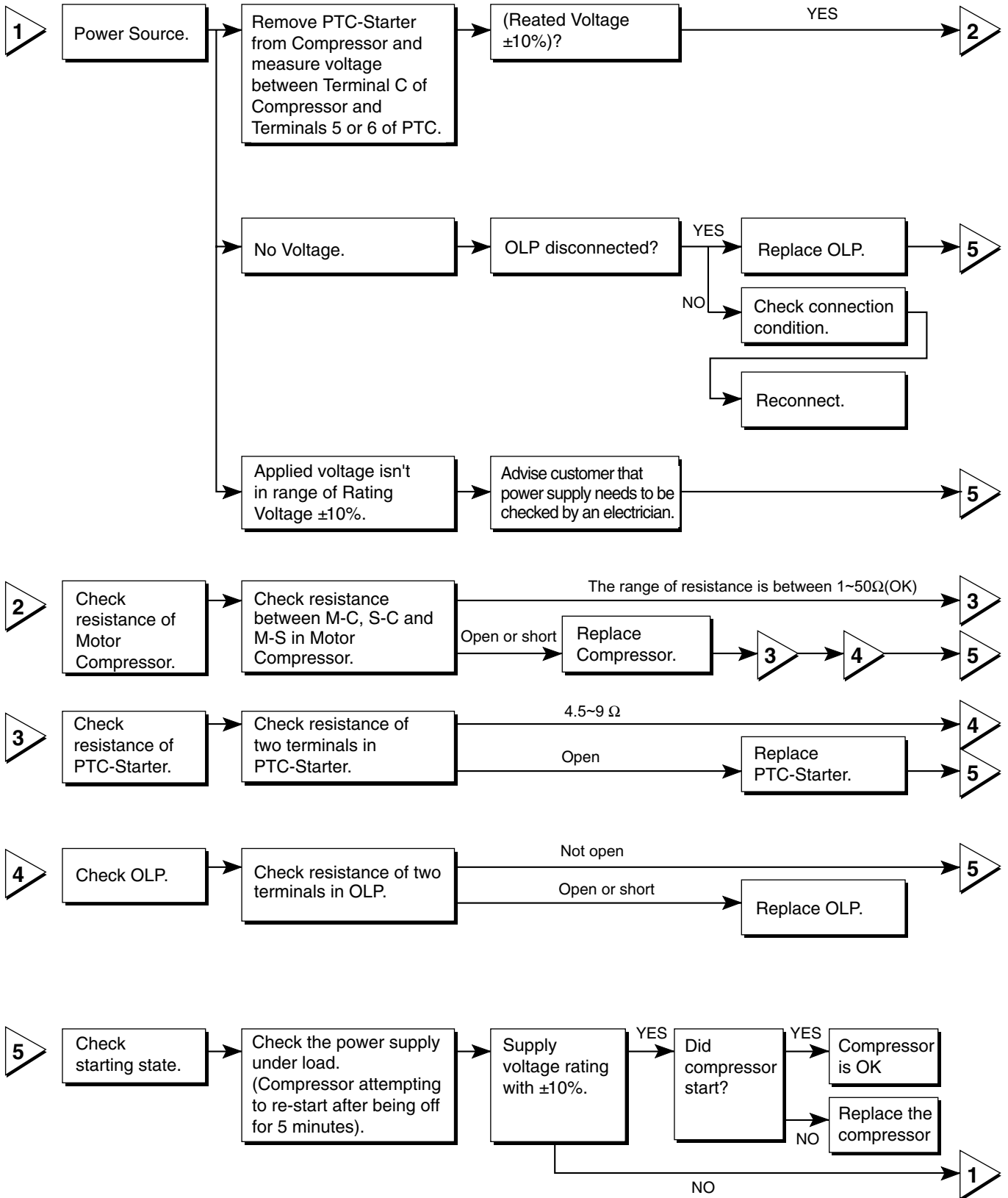

6-2 PTC AND OLP

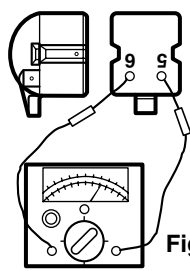
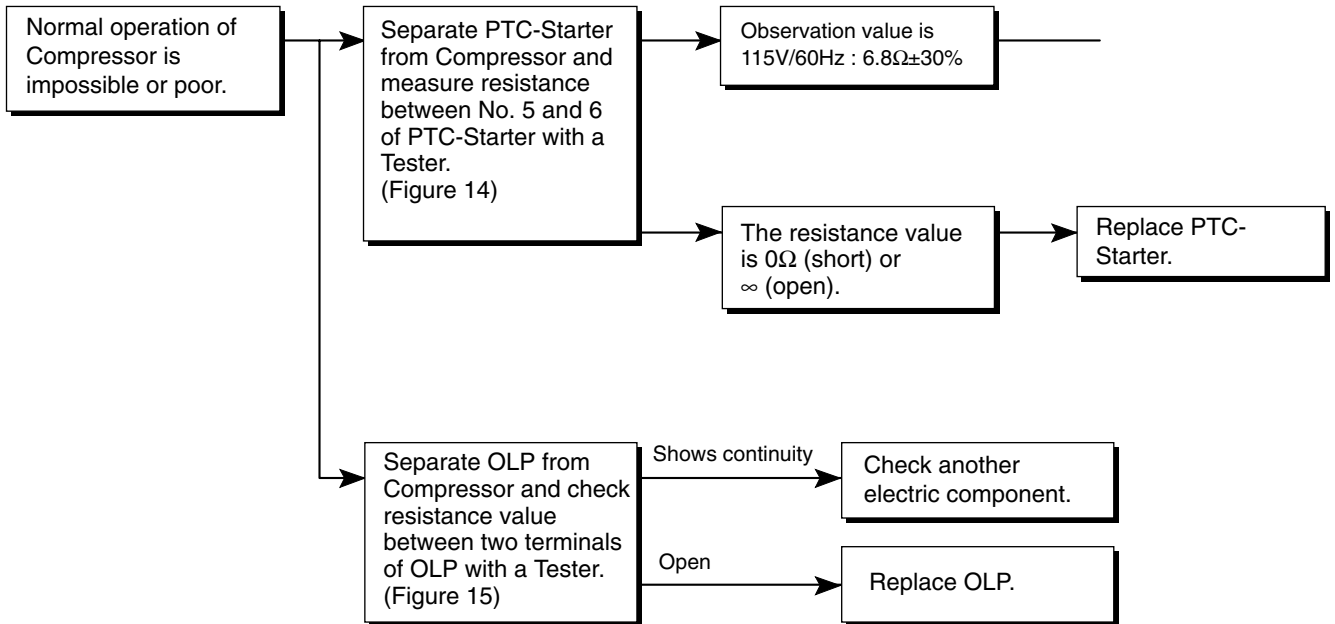

Figure 14

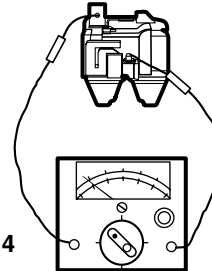
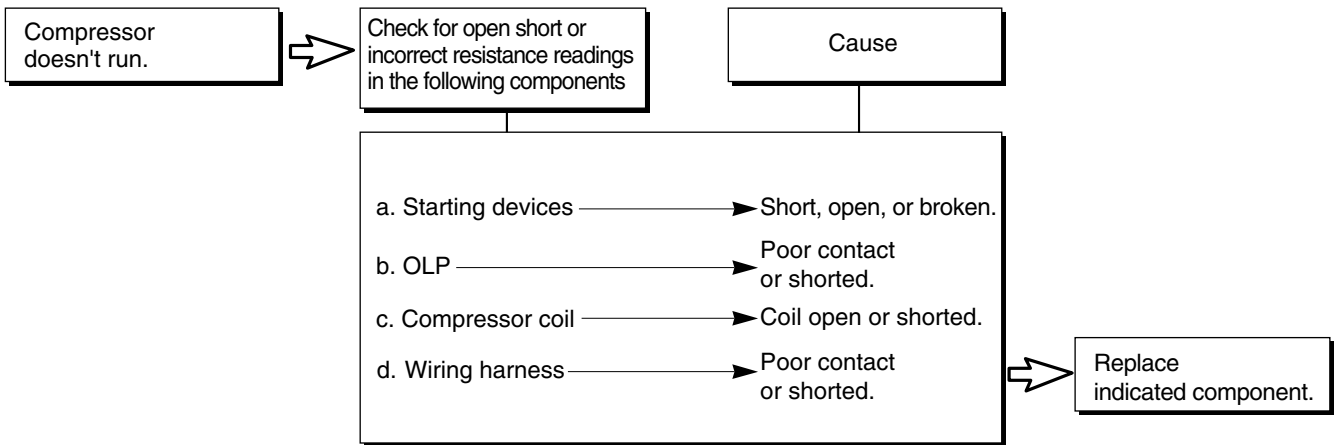

Figure 15

6-3 OTHER ELECTRICAL COMPONENTS

▼ Not cooling at all



▼ Poor cooling performance

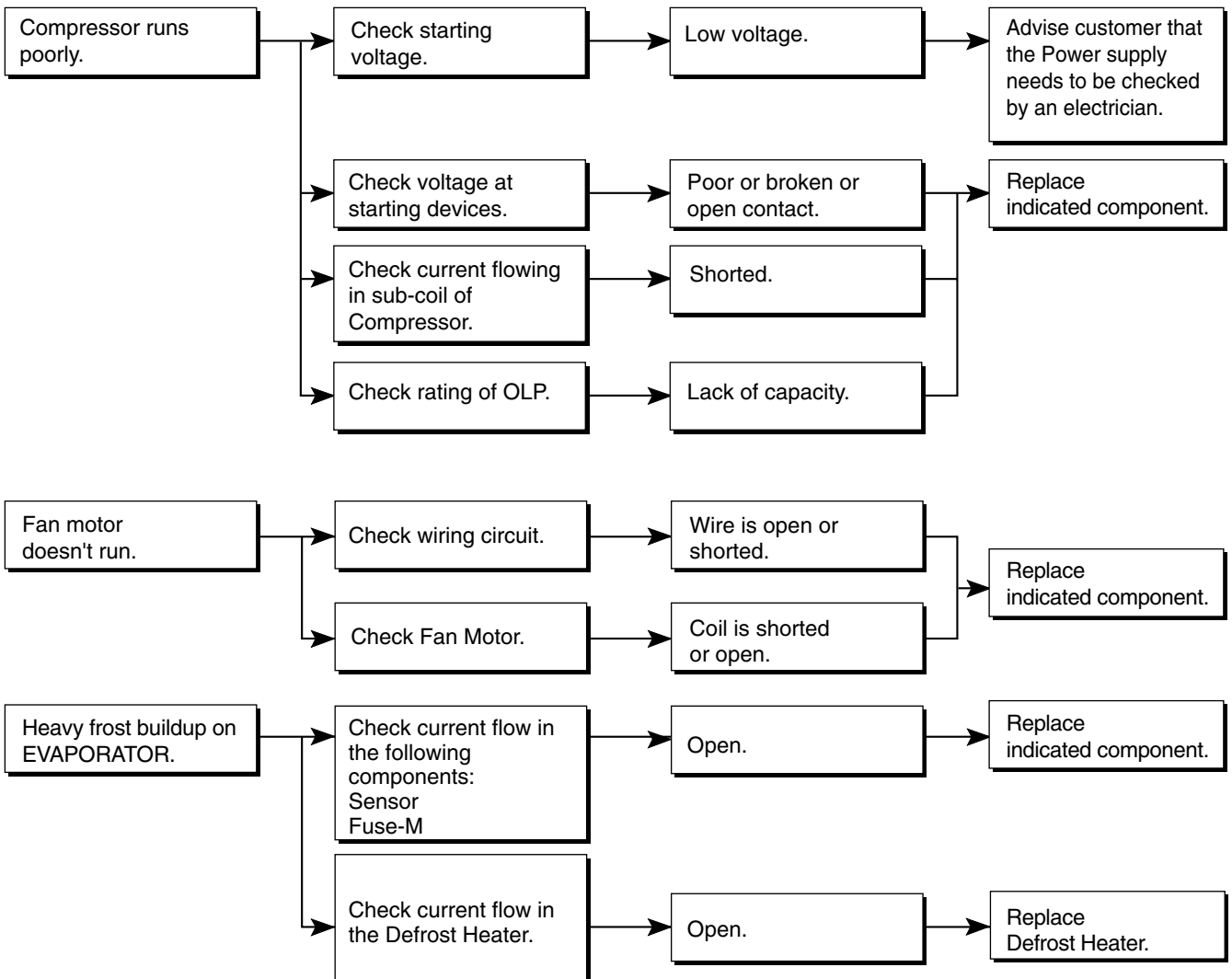

6-4 SERVICE DIAGNOSIS CHART

COMPLAINT	POINTS TO BE CHECKED	REMEDY
No Cooling.	<ul style="list-style-type: none"> • Is the power cord unplugged from the outlet? • Check if the power switch is set to OFF. • Check if the fuse of the power switch is shorted. • Measure the voltage of the power outlet. 	<ul style="list-style-type: none"> • Plug into the outlet. • Set the switch to ON. • Replace the fuse. • If the voltage is low, correct the wiring.
Cools poorly.	<ul style="list-style-type: none"> • Check if the unit is placed too close to the wall. • Check if the unit is placed too close to the stove, gas cooker, or in direct sunlight. • Is the ambient temperature too high or the room door closed? • Check if food put in the refrigerator is hot. • Did you open the door of the unit too often or check if the door is sealed properly? • Check if the Control is set to Warm position. 	<ul style="list-style-type: none"> • Place the unit about 4 inches (10 cm) from the wall. • Place the unit away from these heat sources. • Lower the ambient temperature. • Put in foods after they have cooled down. • Don't open the door too often and close it firmly. • Set the control to Recommended position.
Foods in the Refrigerator are frozen.	<ul style="list-style-type: none"> • Is food placed in the cooling air outlet? • Check if the control is set to colder position. • Is the ambient temperature below 41°F(5°C)? 	<ul style="list-style-type: none"> • Place foods in the high-temperature section. (front part) • Set the control to Recommended position. • Set the control to Warm position.
Condensation or ice forms inside the unit.	<ul style="list-style-type: none"> • Is liquid food sealed? • Check if food put in the refrigerator is hot. • Did you open the door of the unit too often or check if the door is sealed properly? 	<ul style="list-style-type: none"> • Seal liquid foods with wrap. • Put in foods after they have cooled down. • Don't open the door too often and close it firmly.
Condensation forms in the Exterior Case.	<ul style="list-style-type: none"> • Check if the ambient temperature and humidity of the surrounding air are high. • Is there a gap in the door gasket? 	<ul style="list-style-type: none"> • Wipe moisture with a dry cloth. It will disappear in low temperature and humidity. • Fill up the gap.
There is abnormal noise.	<ul style="list-style-type: none"> • Is the unit positioned in a firm and even place? • Are any unnecessary objects placed in the back side of the unit? • Check if the Drip Tray is not firmly fixed. • Check if the cover of the compressor enclosure in the lower front side is taken out. 	<ul style="list-style-type: none"> • Adjust the Leveling Screw, and position the refrigerator in a firm place. • Remove the objects. • Fix the Drip Tray firmly in the original position. • Place the cover in its original position.
Door does not close well.	<ul style="list-style-type: none"> • Check if the door gasket is dirty with an item like juice. • Is the refrigerator level? • Is there too much food in the refrigerator? 	<ul style="list-style-type: none"> • Clean the door gasket. • Position in the firm place and level the Leveling Screw. • Make sure food stored in shelves does not prevent the door from closing.
Ice and foods smell unpleasant.	<ul style="list-style-type: none"> • Check if the inside of the unit is dirty. • Are foods with a strong odor unwrapped? • The unit smells of plastic. 	<ul style="list-style-type: none"> • Clean the inside of the unit. • Wrap foods that have a strong odor. • New products smell of plastic, but this will go away after 1-2 weeks.

● Other possible problems:

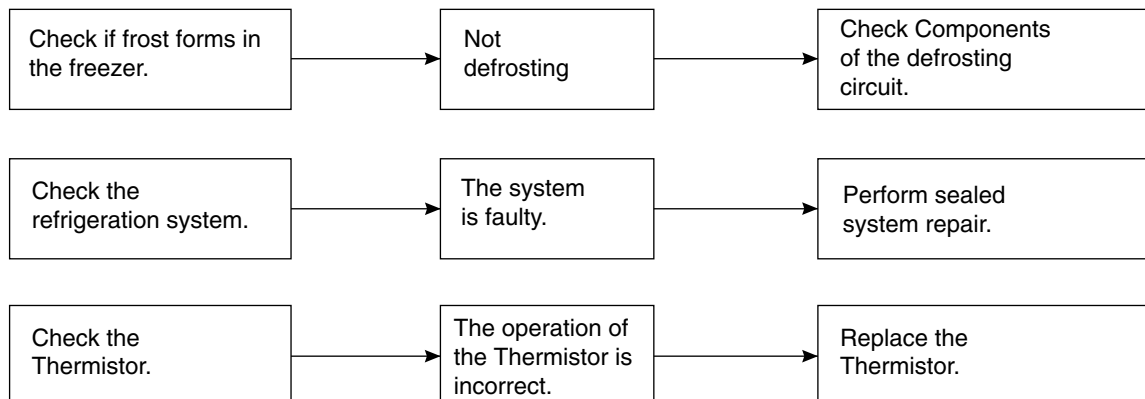

6-5 REFRIGERATION CYCLE

▼ Troubleshooting Chart

CAUSE		STATE OF THE UNIT	STATE OF THE EVAPORATOR	TEMPERATURE OF THE COMPRESSOR	REMARKS
LEAKAGE	PARTIAL LEAKAGE	Freezer compartment and Refrigerator don't cool normally.	Low flowing sound of Refrigerant is heard and frost forms in inlet only.	A little higher than ambient temperature.	<ul style="list-style-type: none"> Refrigerant level is low due to a leak. Normal cooling is possible by restoring the normal amount of refrigerant and repairing the leak.
	COMPLETE LEAKAGE	Freezer compartment and Refrigerator don't cool normally.	Flowing sound of refrigerant is not heard and frost isn't formed.	Equal to ambient temperature.	<ul style="list-style-type: none"> No discharging of Refrigerant. Normal cooling is possible by restoring the normal amount of refrigerant and repairing the leak.
CLOGGED BY DUST	PARTIAL CLOG	Freezer compartment and Refrigerator don't cool normally.	Flowing sound of refrigerant is heard and frost forms in inlet only.	A little higher than ambient temperature.	<ul style="list-style-type: none"> Normal discharging of the refrigerant. The capillary tube is faulty.
	WHOLE CLOG	Freezer compartment and Refrigerator don't cool.	Flowing sound of refrigerant is not heard and frost isn't formed.	Equal to ambient temperature.	<ul style="list-style-type: none"> Normal discharging of the Refrigerant.
MOISTURE CLOG		Cooling operation stops periodically.	Flowing sound of refrigerant is not heard and frost melts.	Lower than ambient temperature.	<ul style="list-style-type: none"> Cooling operation restarts when heating the inlet of the capillary tube.
DEFECTIVE COMPRESSION	COMP-RESSION	Freezer and Refrigerator don't cool.	Low flowing sound of refrigerant is heard and frost forms in inlet only.	A little higher ambient temperature.	<ul style="list-style-type: none"> Low pressure at high side of compressor due to low refrigerant level.
	NO COMP-RESSION	No compressing operation.	Flowing sound of refrigerant is not heard and there is no frost.	Equal to ambient temperature.	<ul style="list-style-type: none"> No pressure in the high pressure part of the compressor.

▼ Leakage Detection

- Observe the discharging point of the refrigerant, which may be in the oil discharging part of the compressor and in a hole in the evaporator.

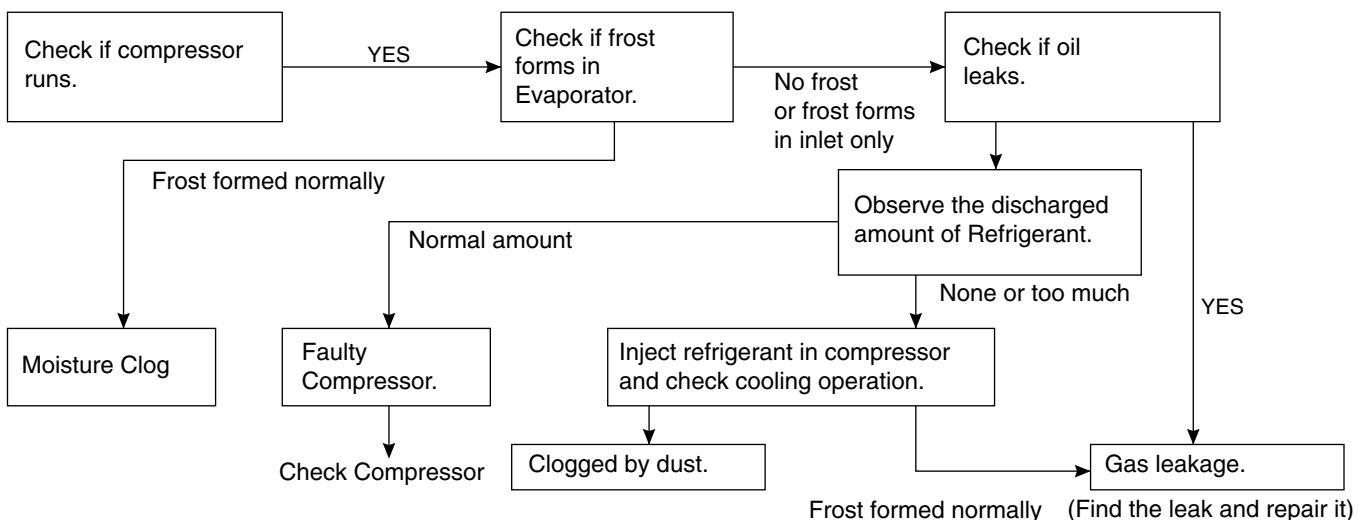

▼ General Control of Refrigerating Cycle

NO.	ITEMS	UNIT	STANDARDS	PURPOSES	REMARKS	
1	Pipe and piping system opening time	Min.	Pipe: within 1 hour. Comp: within 10 minutes. Drier: within 20 minutes.	To protect moisture penetration.	The opening time should be reduced to a half of the standards during rain and rainy seasons (the penetration of water into the pipe is dangerous).	
2	Welding	Nitrogen pressure	Weld under Nitrogen atmosphere. (N ₂ pressure: 0.1~0.2 kg/cm ²)	To protect oxide scale formation.	- Refer to repair note in each part. - R-134a refrigerant is more susceptible to leaks than R-12 and requires more care during welding. - Do not apply force to pipes before and after welding to protect pipe from cracking.	
3	N ₂ sealed parts	Confirm N ₂ leak	Confirm the sound of pressure relief when removing the rubber cap. Sound: usable No sound: not usable	To protect moisture penetration.	- In case of evaporator parts, if it doesn't make sound when removing rubber cap, blow dry air or N ₂ gas for more than 1 min. and then use the parts.	
4	Refrigeration Cycle	Evacuation time	Min.	More than 40 minutes	To remove moisture.	
		Vacuum degree	Torr	Below 0.03 (ref)		Note: Only applicable to the model equipped with reverse flow protect plate.
		Vacuum	EA	High and low pressure sides are evacuated at the same time for models above 200 l.		Vacuum efficiency can be improved by operating compressor during evacuation.
		Vacuum piping	EA	Use R-134a manifold exclusively.	To protect mixing of mineral and ester oils.	The rubber pipes for R-12 refrigerant will be melted when they are used for R-134a refrigerant (causes of leak.)
		Pipe coupler	EA	Use R-134a manifold exclusively.	To protect R-12 refrigerant mixing.	
		Outlet (Socket)		R-134a manifold exclusively.	To protect R-12 refrigerant mixing.	
		Plug		R-134a manifold exclusively.	To protect R-12 refrigerant mixing.	
5	Refrigerant weighing	EA	Use R-134a exclusively. Weighing allowance: ±5g Note: Winter: -5g Summer: +5g	Do not mix with R-12 refrigerant.	- Do not weigh the refrigerant at too hot or too cold an area. (77°F [25°C] is adequate.) - Make Copper charging canister (Device filling refrigerant) Socket: 2SV Plug: 2PV R-134a Note: Do not burn O-ring (bushing) during welding.	
6	Drier replacement		- Use R-134a exclusively for R-134a refrigerator. - Replace drier whenever repairing refrigerator cycle piping.	To remove the moisture from pipe inside.		
7	Leak check		- Do not use soapy water for check. It may be sucked into the pipe by a vacuum.	Defect in refrigerant leak area.	- Check for an oil leak at the refrigerant leak area. Use an electronic leak detector if an oil leak is not found. - The electronic leak detector is very sensitive to halogen gas in the air. It also can detect R-141b in urethane. Practice many times before using this type of detector to avoid false readings.	

7. OPERATION PRINCIPLE AND REPAIR METHOD OF ICEMAKER

7-1 OPERATION PRINCIPLE

7-1-1 Operation Principle of IceMaker

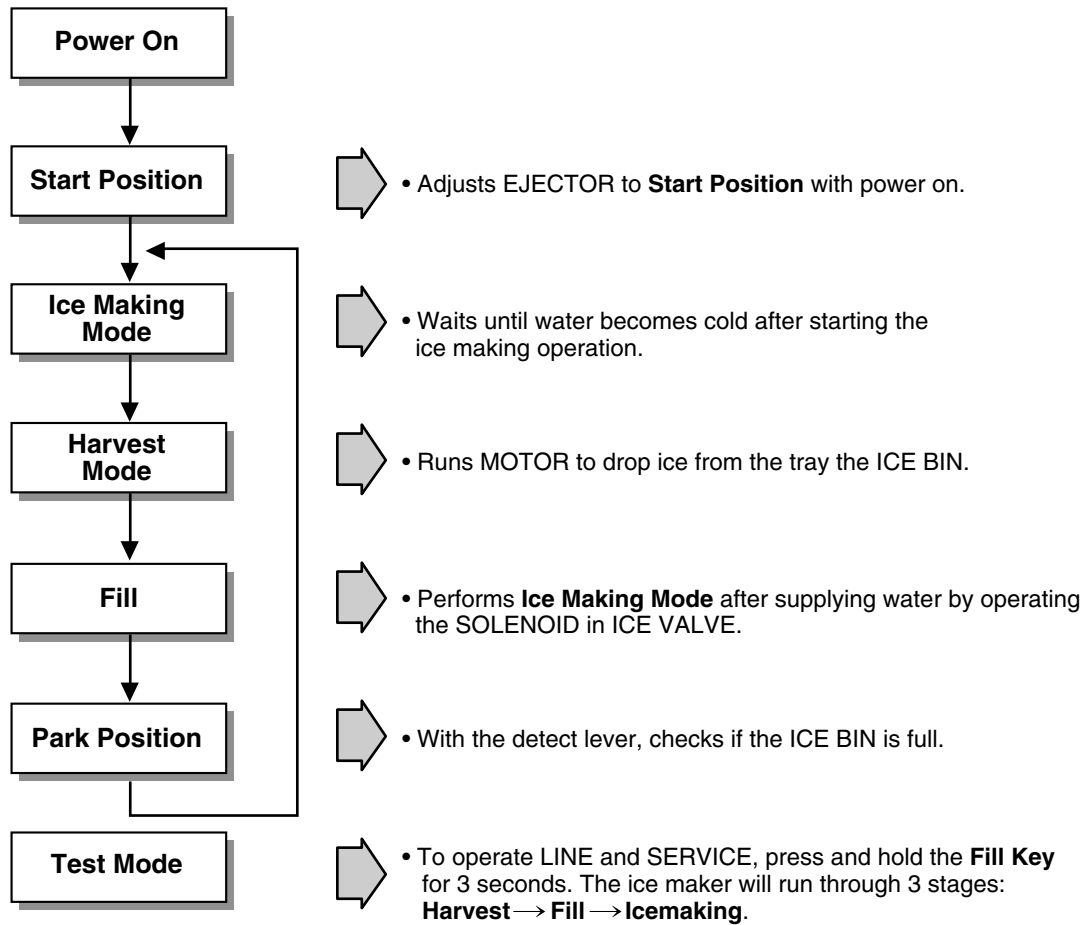

1. Turning the Icemaker stop switch off (O) stops the ice making function.
2. Setting the Icemaker switch to OFF and then turning it back on will reset the icemaker control.

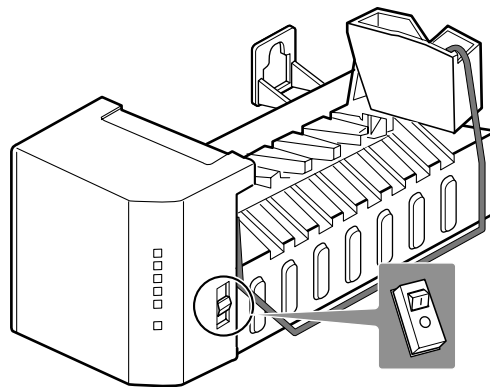

7-2 CONTROL METHOD ACCORDING TO FUNCTIONS

7-2-1 Start Position

1. After POWER OFF or Power Outage, check the EJECTOR's position with MICOM initialization to restart.
2. How to check if it is in place:
 - Check **HIGH/LOW** signals from HALL SENSOR in MICOM PIN.
3. Control Method to check if it is in place:
 - (1) EJECTOR is in place,
 - It is an initialized control, so the mode can be changed to ice making control.
 - (2) EJECTOR isn't in place:
 - A. If EJECTOR is back in place within 2 minutes with the motor on, it is being initialized. If not, go to Step B.
 - B. If EJECTOR is back in place within 18 minutes with the heater on (to control Heater on its OFF condition), it is being initialized. If not, it is not functioning. Repeat Step B with Heater and Motor off.

7-2-2 Ice Making Mode

1. Ice Making control refers to the freezing of supplied water in the ice trays. Complete ice making operations by measuring the temperature of the Tray with Ice-Making SENSOR.
2. Ice Making starts after completing fulfilled ice control and initial control.
3. The Ice Making function is completed when the sensor reaches 19°F(-7°C), 60 to 240 minutes after starting.
4. If the temperature sensor is defective, the ice-making function will be completed in 4 hours.

7-2-3 Harvest Mode

1. Ice-removing control refers to the operation of dropping cubes into the ice bin from the tray when ice-making has completed.
2. Ice removing control mode:
 - (1) Operates Heater for 30 seconds; then operate MOTOR.
 - (2) After performing Step 1 (to control the Heater on its off condition), Ice-Removal control will be back in place within 18 minutes. (Hall SENSOR sign = OV). Ice removal is then complete. Then change the mode to the water supply control. If this control phase fails to start, it is not functioning. Put the Heater and Motor in the off position. Restart every 2 hours. (Refer to fig.1)



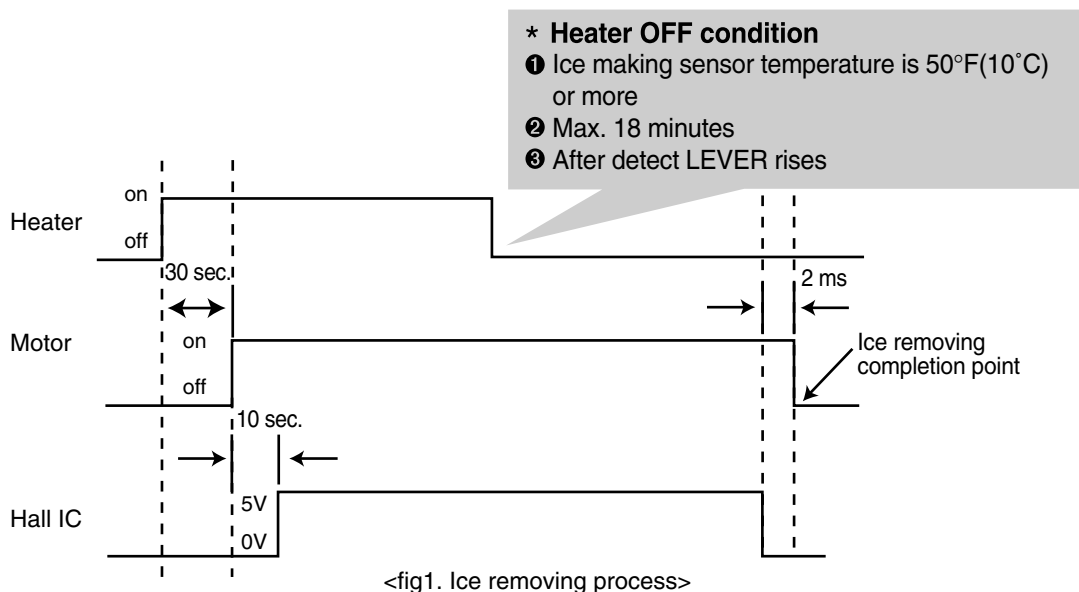

NOTE : If the motor malfunctions and starts before the detect lever rises, MICOM regards the Ice-Removing phase as completed. Water then starts flowing. To prevent this, MICOM doesn't switch to water-supply mode, but restarts the ice-removing mode. If this happens 3 times, the motor is malfunctioning and you should stop the loads (Heater, Motor). Then restart the Ice-Removing mode every 2 hours. (See Step 2 above.)



7-2-4 Fill / Park Position

1. When Ice-Removing control (Normal Ice-Removing control, Ice-Removing control for test) has completed, and the EJECTOR is in place, this control operates the ICE SOLENOID by time check in the compressor enclosure of the refrigerator. Then it supplies water to the ice making tray.
2. Water supply level is adjustable in levels 1-5 by pressing the water supply control Switch and fill time will be determined by the selected level.

Water supply amount TABLE

STAGE	TIME TO SUPPLY	INDICATIONS	REMARKS
1	6 sec.		The water amount will vary depending on the water control Switch setting, as well as the water pressure of the connected water line.
2	7 sec.		
3	8 sec.		
4	9 sec.		
5	10 sec.		



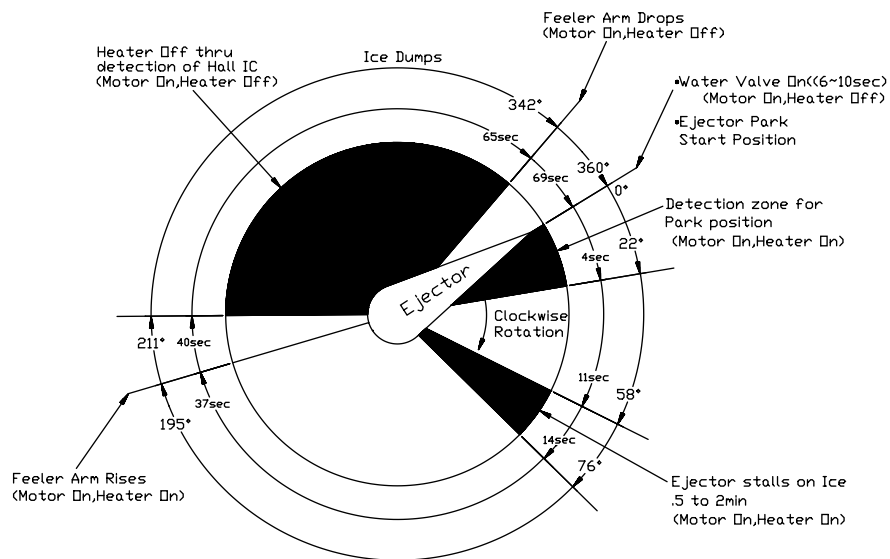

NOTE : Below is an example used by another vendor as an explanation of what is taking place.



7-2-5 Function TEST



1. This is a compulsory operation for TEST, SVC, cleaning, etc. It is operated by pressing the water supply control KEY for 3 seconds.
2. It operates in the Ice Making mode, but not in the Ice-Removing mode or water supply process. (If there is an ERROR, it can only be checked in the TEST mode.)
3. If the water supply control KEY is pressed for 3 seconds in the Ice-Making mode (no matter what condition the Ice-Making tray is in) the Ice-Removing operation starts immediately. Water is not yet frozen, so water is poured instead of ice. If the control doesn't operate normally in the TEST mode, check and repair as needed.
4. After water is supplied, the normal CYCLE is followed: **ice making** → **Harvest** → **Fill** → **Park Position**.
5. When Stage 5 is completed in the TEST mode, minimize MICOM in 5 seconds, the time needed to supply water resets to the previous status in the TEST mode.

Diagnosis TABLE

STAGE	ITEMS	INDICATOR	REMARKS
1	HEATER		Five seconds after heater starts, heater will go off if temperature recorded by sensor is 10°C or lever is in up position.
2	MOTOR		Five seconds after heater starts, you can confirm that motor is moving.
3	HALL IC (detection of position) I		You can confirm Hall Ic detection of position.
4	VALVE		Two seconds after detection of initial position, you can confirm that valve is on.
5	HALL IC (detection of full-filled Ice) II		You can check whether hall is sensing Full ice condition. (If there is a full-filled error, the fifth LED is not on.)
6	reset	Mark previous status on TEST mode	Five seconds after fifth stage is completed, the icemaker reset at initial status.

7-3 DEFECT DIAGNOSIS FUNCTION

7-3-1 ERROR CODES shown on Ice Maker water supply control panel

NO	DIVISION	INDICATOR	CONTENTS	REMARKS
1	Normal	Mark time to supply	None	Display switch operates properly
2	Ice-Making Sensor malfunction		Cut or short-circuited wire	Make sure that the wire on each sensor is connected.
3	Ice Maker Kit malfunction		When ejector blades don't reach park position over 18 minutes since Harvest Mode starts.	Defects of HALL IC/MOTOR/HEATER/RELAY

ERROR indicators in table can be checked only in TEST mode.

8. DESCRIPTION OF FUNCTION & CIRCUIT OF MICOM

8-1 FUNCTION

8-1-1 Function

1. When the appliance is plugged in, it is set to 37 °F for the Refrigerator and 0 °F for the Freezer.
You can adjust the Refrigerator and the Freezer control temperature by pressing the COLDER button or the WARMER button.
2. When the power is initially applied or restored after a power failure, it is set to the setting temperature as you set before power off. (applied to DISPENSER MODEL)

DISPENSER MODEL

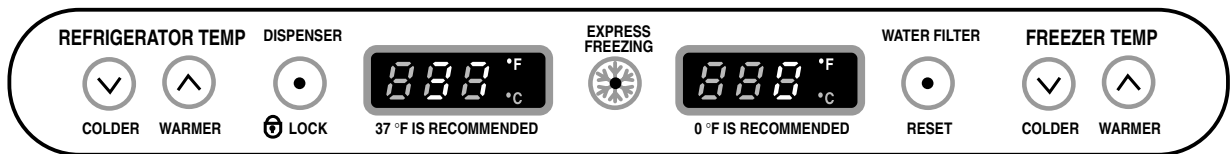

Control range : 32°F ~ 46°F
0°C ~ 8°C

Control range : -6°F ~ 9°F
-21°C ~ -13°C

BEST MODEL

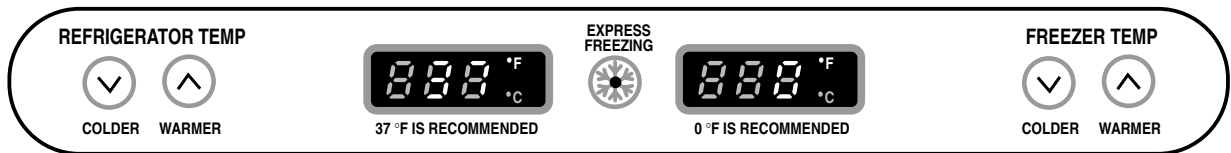

Control range : 32°F ~ 46°F
0°C ~ 8°C

Control range : -6°F ~ 9°F
-21°C ~ -13°C

8-1-2 How to Change the Temperature Mode to °F / °C

1. The setting temperature mode can be changed to °F / °C by pressing and holding COLDER key of Freezer and COLDER key of Refrigerator over 1 seconds. at the same time.
2. The initial setting is °F. Whenever the mode is changed, the LED lights are changed.

8-1-3 Dispenser Lock

1. Press and hold the DISPENSER LOCK button for 3 seconds to lock the dispenser.
2. When locked, the LED is off and the dispenser function is turned off.
3. Press and hold the DISPENSER LOCK button again for 3 seconds to unlock the dispenser. The LED will be on and the dispenser will function normally.

8-1-4 CONTROL OF FREEZER FAN MOTOR

1. Freezer fan motor has high and standard speeds.
2. High speed is used at power-up, for express freezing, and when refrigerator is overloaded.
Standard speeds is used for general purposes.
3. To improve cooling speed, the RPM of the freezer fan motor change from normal speed to high.
4. High speed (2700RPM) : Initial power on or load corresponding operation, express freezing.
Normal speed (2400RPM) : General working conditions.
5. Fan motor stops when refrigerator or freezer door opens.

8-1-5 EXPRESS FREEZING

1. The purpose of this function is to intensify the cooling speed of freezer and to increase the amount of ice.
2. Whenever selection switch is pressed, selection/release, the LED will turn ON or OFF.
3. If there is a power cutage and the refrigerator is power on again, EXPRESS FREEZING function will be canceled.
4. To activate these function, to press the Express Freezing key and the LED will turn ON. This function will remain activated for 24 hrs. The first three hours the compressor and Freezer Fan will be ON. The next 21 hours the freezer will be controlled at the lowest temperature. After 24 hours or if the Express Freezing key is pressed again, the freezer will return to its previous temperature.
5. For the first three hours notice the following cases:
 - (1) Compressor and freezer fan (HIGH RPM) continuously operate for three hours.
 - (2) If defrost starts during EXPRESS FREEZING, EXPRESS FREEZING operates for the rest of time after defrost is completed, when EXPRESS FREEZING operation time is less than 90 minutes.
If EXPRESS FREEZING operates for more than 90 minutes, the EXPRESS FREEZING will operate for two hours after defrost is completed.
 - (3) If EXPRESS FREEZING is pressed during defrost, EXPRESS FREEZING LED is on but this function will start seven minutes after defrost is completed and it shall operate for three hours.
 - (4) If EXPRESS FREEZING is selected within seven minutes after compressor has stopped, the compressor (compressor delays seven minutes) shall start after the balance of the delay time.
 - (5) The fan motor in the freezer compartment runs at high speed during EXPRESS FREEZING .
6. For the rest of the 21 hours, the freezer will be controlled at the lowest temperature.

8-1-6 REFRIGERATOR LAMP AUTO OFF

1. To avoid heat damage caused by the lamp, it is turned off automatically when the refrigerator door is open for more than 7 minutes.

8-1-7 Alarm for Open Door

1. This feature sounds a buzzer when the freezer or refrigerator door is not closed within 1 minute after it is opened.
2. One minute after the door is opened, the buzzer sounds three times each for 1/2 seconds. These tones repeat every 30 seconds.
3. The alarm is cancelled when the freezer or the refrigerator is closed while the buzzer sounds.

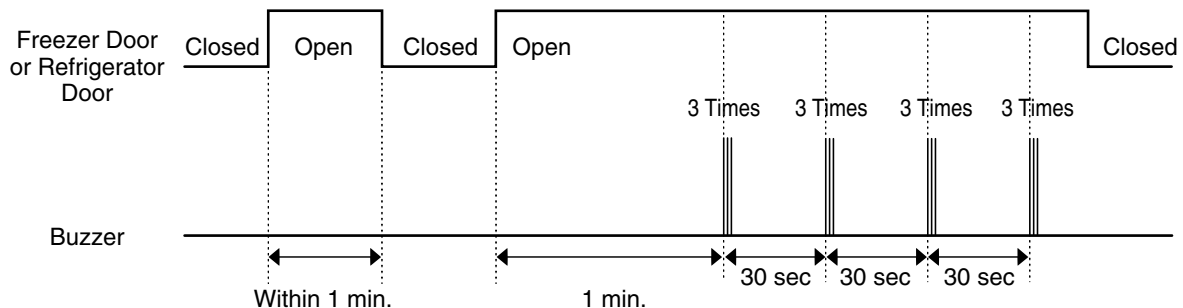

8-1-8 Buzzer Sound

When the button on the front Display is pushed, a Ding~ Dong~ sound is produced.
(Refer to the Buzzer Circuit 8-2-4 No. 3)

8-1-9 Defrosting (removing frost)

1. Defrosting starts each time the COMPRESSOR running time reaches 7 hours.
2. For initial power on or for restoring power, defrosting starts when the compressor running time reaches 4 hours.
3. Defrosting stops if the sensor temperature reaches 46.4°F(8°C) or more. If the sensor doesn't reach 46.4°F(8°C) in 2 hours, the defrost mode is malfunctioning. (Refer to the defect diagnosis function, 8-1-13.)
4. Defrosting won't function if its sensor is defective (wires are cut or short circuited)

8-1-10 Filter Replacement Indication

1. In 6 months after the UNIT (refrigerator) is power on, or after 28,000 seconds of dispenser use, the water filter Indicator LED (red color) will be ON.
2. When the water filter indicator LED is illuminated, you should change the water filter. After this, you must press the water filter button for three seconds and you will hear a ding-dong sound.
The LED will be OFF. This operation will indicate that the UNIT is reset to its initial conditions, so this process is restarted.

8-1-11 Power Failure Compensation Function

1. When the UNIT is power off, the Fresh Food and Freezer Temperature notches, the filter elapsed time for replacement, the temperature mode (°C or °F) and the dispenser lock mode are saved in the EEPROM.
2. When the UNIT is power on, the MICOM will read the specified EEPROM addresses to restore the values indicated in the previous paragraph.

8-1-12 Electrical Parts Are Turned On Sequentially

Electrical parts such as COMP, defrosting heater, freezer FAN, etc. are turned on in the following order to prevent noise and parts damage. Several parts are started at the same time at initial power on and are turned off together when TEST is completed.

OPERATING		ORDERS				
Initial power on	Temperature of Defrosting Sensor is 113°F(45°C) or more (when unit is newly purchased or when moved)	POWER ON	in 1/2 second →	COMP ON	in 1/2 second →	Freezer FAN ON
	Temperature of defrosting sensor is lower than 113°F(45°C) (when power cuts, SERVICE)	POWER ON	in 1/2 second →	Defrosting heater ON	in 10 second →	Defrosting heater OFF
		in 1/2 second →	COMP ON	in 1/2 second →	Freezer FAN ON	
	Reset to normal operation from TEST MODE	Total load OFF	in 7 minute →	COMP ON	in 1/2 second →	Freezer FAN ON

8-1-13 Defect Diagnosis Function

1. Automatic diagnosis makes servicing the refrigerator easy.
2. When a defect occurs, the buttons will not operate; but the tones. such as ding. will sound.
3. When the defect CODE removes the sign, it returns to normal operation (RESET).
4. The defect CODE shows on the Refrigerator and Freezer Display.

DISPENSER MODEL

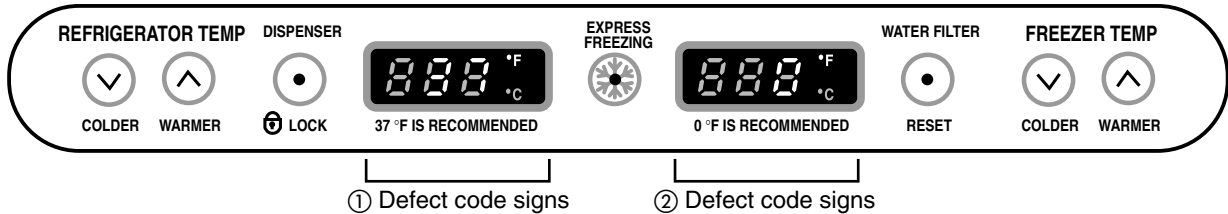

BEST MODEL

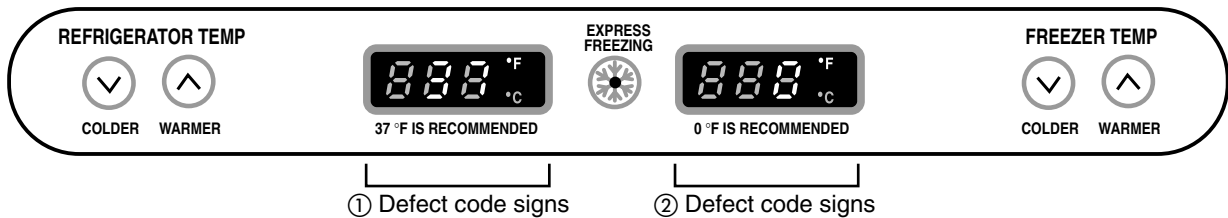

ERROR CODE on display panel

NO	ITEM	ERROR CODE		CONTENTS	REMARKS
		①	②		
1	Failure of freezer sensor	Er	F5	Cut or short circuit wire	Inspect Connecting wires on each sensor
2	Failure of Refrigerator sensor	Er	r5	Cut or short circuit wire	
3	Failure of defrost sensor	Er	d5	Cut or short circuit wire	
4	Failure of defrost mode	Er	dH	When defrost sensor doesn't reach 8°C within 2 hours after starting defrost.	Snapping of defrost heater or Temperature fuse, pull-out of Connector (indicated minimum 2 Hours after failure occurs)
5	Failure of BLDC FAN MOTOR at freezing compartment.	Er	FF	If there is no fan motor signal For more than 65sec. in Operation fan motor	Poor motor, hooking to Wires of fan, contact of structures to fan, snapping or short circuit of Lead wire

8-1-14 TEST Mode

1. The Test mode allows checking the PCB and the function of the product as well as finding out the defective part in case of an error.
2. The test mode is operated by pressing two buttons at Display panel.
3. While in the test mode, the function control button is not recognized, but the recognition tone (beep~) sounds.
4. After exiting the test mode, be sure to reset by unplugging and then plugging in the appliance.
5. If an error, such as a sensor failure, is detected while in the test mode, the test mode is cleared and the error code is displayed.
6. While an error code is displayed, the test mode will not be activated.

MODE	MANIPULATION	CONTENTS	REMARKS
TEST1	Push Express Freezing key and COLDER KEY of Freezer Temp. at the same time over 3 seconds.	<ol style="list-style-type: none"> 1. Continuous operation of the COMPRESSOR 2. Continuous operation of the freezer fan 3. STEPPING DAMPER OPEN 4. Defrosting Heater OFF 5. Every DISPLAY LED ON 	
TEST2	Push Express Freezing key and COLDER KEY of Freezer Temp. at the same time over 3 seconds in TEST MODE 1	<ol style="list-style-type: none"> 1. COMP OFF 2. Freezer FAN OFF 3. STEPPING DAMPER CLOSE 4. Defrosting heater ON 5. DISPLAY LED shows 222 	Reset if the temperature of the Defrosting sensor is 46°F(8°C) or more.
Reset	Push Express Freezing key and COLDER KEY of Freezer Temp. at the same time over 3 seconds. in TEST MODE 2	Reset to the previously setting before TEST MODE	The compressor will Start after a 7-minute delay.

NOTE : LED CHECK MODE: When the WARMER button in the refrigerator temperature control and the WARMER button in the freezer temperature control are pushed and held for 1 second or longer, every LED on the display turns on at the same time. When the buttons are released, the previous mode is restored.

* Freezer Fan RPM Variable Check:

In case the freezer fan is in operation when the WARMER KEY in Refrigerator and Freezer Temp. Control are pressed for more than one second at the same time freezer fan RPM changes. (for example if high speed, to normal speed or if normal speed, to high speed for 30 seconds)
After 30 seconds, it turns to its original RPM.

* Demonstration MODE:

1. When the WARMER KEY of refrigerator Temp. control or of freezer Temp. control in the the warmest temperature's status are pushed and held for 3 seconds or longer, It converts to Demonstration Mode.
2. It shows **OFF** on the display panel.
3. In this status, all Loads are off (Compressor / Fan / Damper / Heater)
(Even is Demonstration Mode, the refrigerator Lamp automatic off function works normally and can be demonstrated)
4. Exit the test mode and reset the display by pressing the COLDER and WARMER buttons.

8-2 PCB FUNCTION

8-2-1 Power Circuit

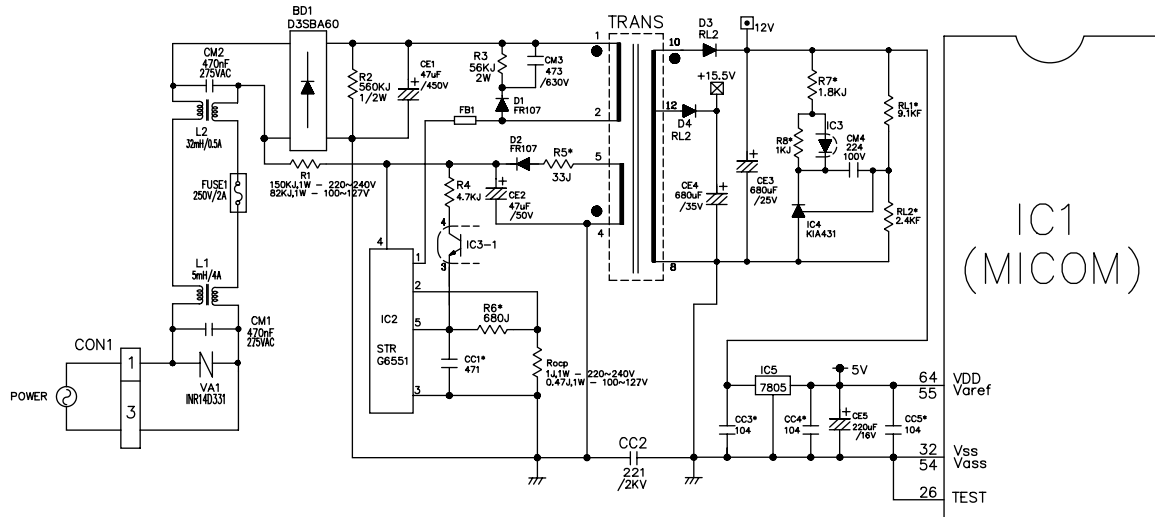

The secondary part of the TRANSFORMER is composed of the power supply for the display, the BLDC FAN Motor drive (15.5 V), the relay drive (12 Vdc) and the MICOM and IC (5 Vdc).

The voltage for each part is as follows:

PART	VA 1	CE 3	CE 4	CE 5
VOLTAGE	115 Vac	12 Vdc	15.5 Vdc	5 V

VA1 is a part for preventing over voltage and noise. When 385V or higher power is applied, the inside elements are short-circuited and broken, resulting in blowout of the fuse in order to protect the elements of the secondary part of the TRANSFORMER.

8-2-2 Oscillation Circuit

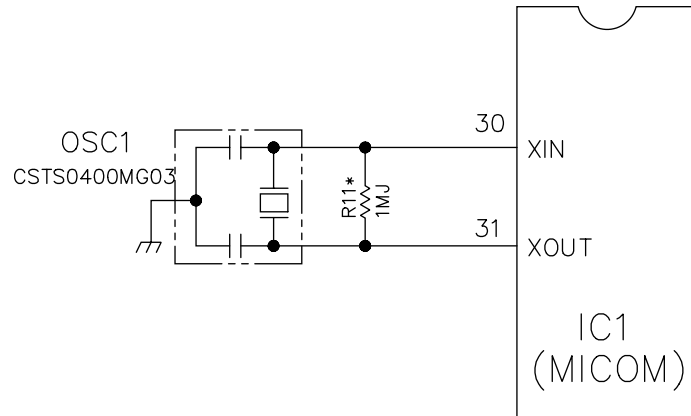

This circuit generates the base clock for calculating time and the synchro clock for transmitting data from and to the inside logic elements of the IC1 (MICOM). Be sure to use specific replacement parts, since calculating time by the IC1 may be changed. If changed, the OSC1 SPEC will not work.

8-2-3 Reset Circuit

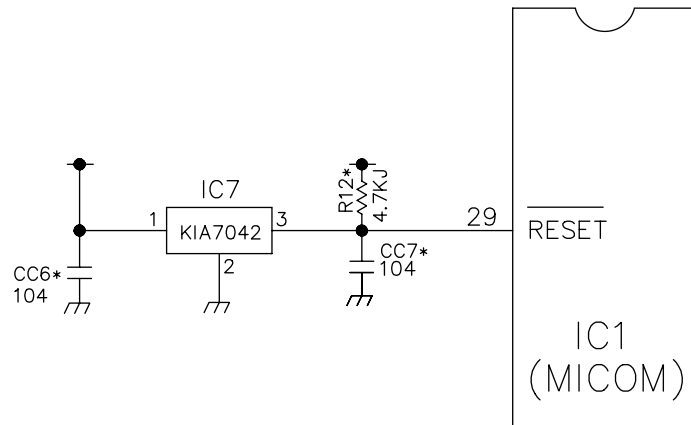

The RESET circuit allows all the functions to start at the initial conditions by initializing various parts, including the RAM inside the MICOM (IC1) when the power is initially supplied or the power supply to the MICOM is restored after a momentary power failure. For the initial 10ms of power supply, LOW voltage is applied to the MICOM RESET terminal. During a normal operation, 5V is applied to the RESET terminal. (If a malfunction occurs in the RESET IC, the MICOM will not operate.)

8-2-4 Load / Buzzer Drive & Open Door Detection Circuit

1. Load Drive Condition Check

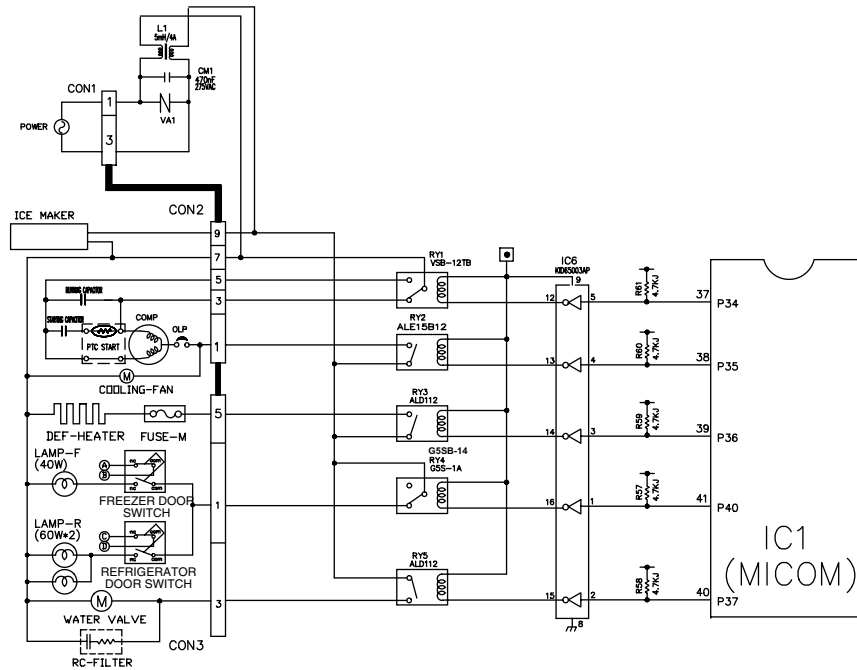

LOAD TYPE		COMP	DEFROSTING HEATER	LAMP	TCM POWER MODE (OPTIONAL)	VALVE (DISPENSER MDL)
Measurement Location (IC6)		NO.13	NO.14	NO.16	NO.12	NO.15
Condition	ON	1V or below				
	OFF	12V				

2. Fan motor driving circuit (freezing compartment fan)

1. This circuit makes standby power 0 by cutting off power supplied to ISs inside of the fan motor in the fan motor OFF.
2. This is a circuit to perform a temporary change of speed for the fan motor and applies DC voltage up to 7.5V ~ 16V to motor.
3. This circuit prevents over-driving the fan motor by cutting off power applied to the fan motor in the lock of fan motor by sensing the operation RPM of the fan motor.

	Ⓐ part	Ⓑ part	Ⓒ part
MOTOR OFF	2V or less	0V	5V
MOTOR ON	13V~15V	0V	2V~3V

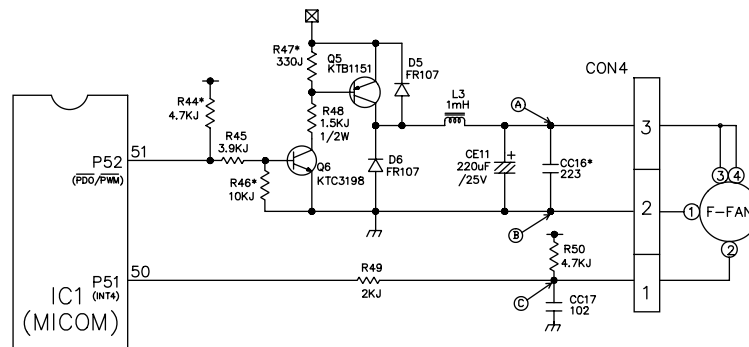

3. Buzzer Drive Condition Check

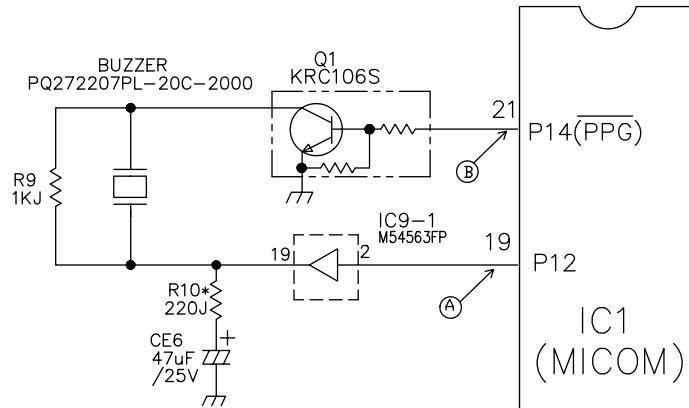

Condition Measurement Location	Tone (Ding~Dong~) when the button on the display is pushed.	Alarm for open door (beep-beep-beep)	OFF
IC1 (A)			0 V
IC1 (B)			0 V

4. Open Door Detection Circuit Check

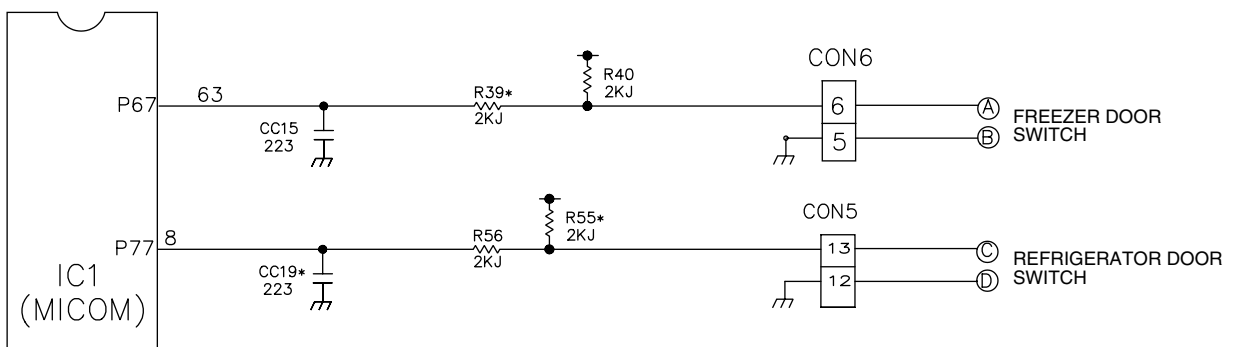

Measurement Location	(PIN NO.63 & PIN NO.8)
Closed	5 V
Open	0 V

8-2-5 Temperature Sensor Circuit

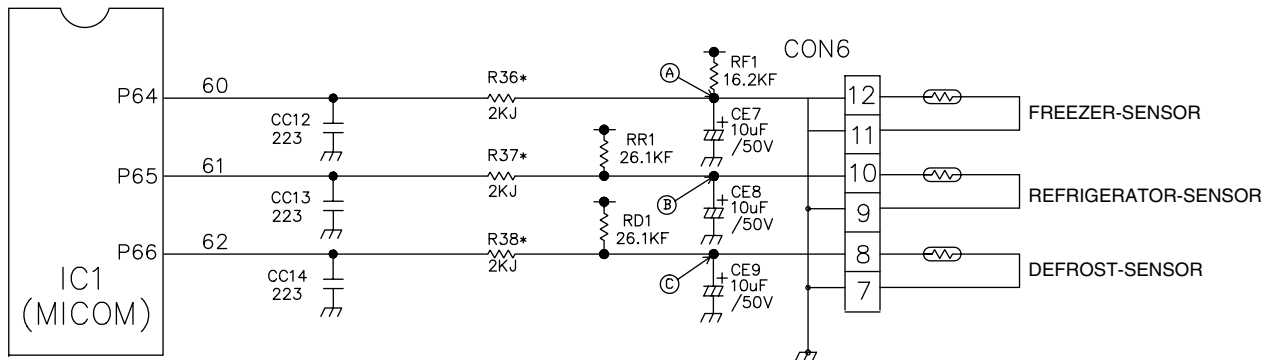

The upper CIRCUIT reads REFRIGERATOR temperature, FREEZER Temperature, and DEFROST-SENSOR temperature for defrosting and the indoor temperature for compensating for the surrounding temperature into MICOM. OPENING or SHORT state of each TEMPERATURE SENSOR are as follows:

SENSOR	CHECK POINT	NORMAL (-30°C ~ 50°C)	SHORT-CIRCUITED	OPEN
Freezer Sensor	POINT (A) Voltage	0.5 V ~ 4.5 V	0 V	5 V
Refrigerator Sensor	POINT (B) Voltage			
Defrosting Sensor	POINT (C) Voltage			

8-2-6 Refrigeration Compartment Stepping Motor Damper Circuit

* The circuit shown below is the damper circuit to regulate the refrigerator temperature.

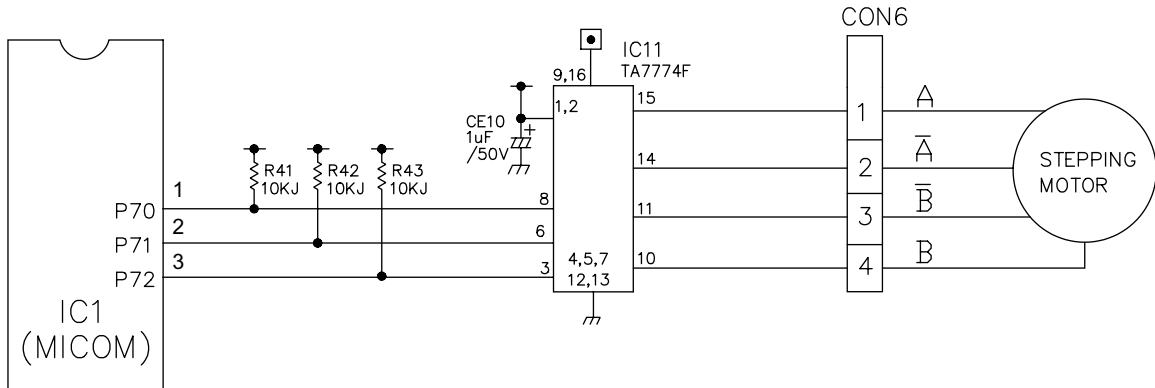

8-2-7 Dispenser Input/LED Output Circuit

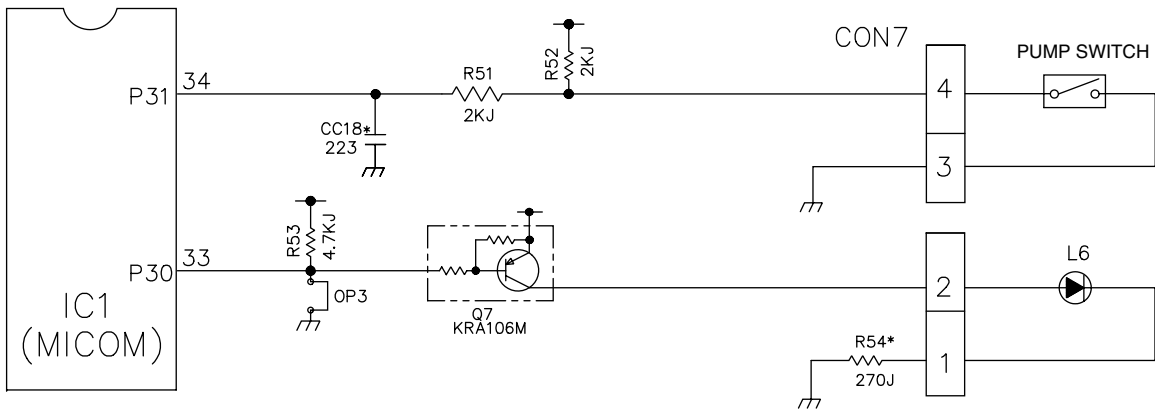

8-2-8 Temperature Compensation & Overcooling/Undercooling Compensation Circuit

1. Refrigerator Temperature Compensation

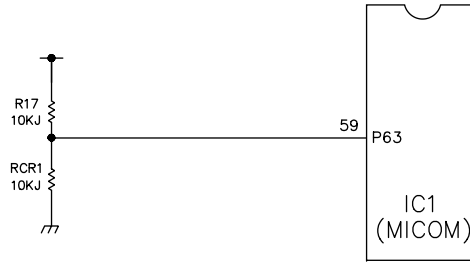

Refrigerator		Remark
Resistance (RCR)	Temperature Compensation	
180 KΩ	+2.5°C	Compensation by raising the temperature ↑
56 KΩ	+2.0°C	
33 KΩ	+1.5°C	
18 KΩ	+1.0°C	
12 KΩ	+0.5°C	
10 KΩ	0 °C	Standard Temperature
8.2 KΩ	-0.5°C	Compensation by lowering the temperature ↓
5.6 KΩ	-1.0°C	
3.3 KΩ	-1.5°C	
2 KΩ	-2.0°C	
470 Ω	-2.5°C	

Table of Temperature Compensation by adjusting the resistance (difference from the current temperature) e.g., If the refrigerator compensation resistance (RCR) is changed from 10K (the current resistance) to 18K (the adjustment resistance), the temperature of the refrigerator rises 33.8°F(+1°C).

2. The temperature compensation for refrigerator compartment is in the following table:

		Revised resistance	470Ω	2kΩ	3.3kΩ	5.6kΩ	8.2kΩ	10kΩ	12kΩ	18kΩ	33kΩ	56kΩ	180kΩ
		Present resistance											
Refrigerator (RCR)	470Ω	No change	0.5°C Up	1°C Up	1.5°C Up	2°C Up	2.5°C Up	3°C Up	3.5°C Up	4°C Up	4.5°C Up	5°C Up	
	2kΩ	0.5°C Down	No Change	0.5°C Up	1°C Up	1.5°C Up	2°C Up	2.5°C Up	3°C Up	3.5°C Up	4°C Up	4.5°C Up	
	3.3kΩ	1°C Down	0.5°C Down	No Change	0.5°C Up	1°C Up	1.5°C Up	2°C Up	2.5°C Up	3°C Up	3.5°C Up	4°C Up	
	5.6kΩ	1.5°C Down	1°C Down	0.5°C Down	No Change	0.5°C Up	1°C Up	1.5°C Up	2°C Up	2.5°C Up	3°C Up	3.5°C Up	
	8.2kΩ	2°C Down	1.5°C Down	1°C Down	0.5°C Down	No Change	0.5°C Up	1°C Up	1.5°C Up	2°C Up	2.5°C Up	3°C Up	
	10kΩ	2.5°C Down	2°C Down	1.5°C Down	1°C Down	0.5°C Down	No Change	0.5°C Up	1°C Up	1.5°C Up	2°C Up	2.5°C Up	
	12kΩ	3°C Down	2.5°C Down	2°C Down	1.5°C Down	1°C Down	0.5°C Down	No Change	0.5°C Up	1°C Up	1.5°C Up	2°C Up	
	18kΩ	3.5°C Down	3°C Down	2.5°C Down	2°C Down	1.5°C Down	1°C Down	0.5°C Down	No Change	0.5°C Up	1°C Up	1.5°C Up	
	33kΩ	4°C Down	3.5°C Down	3°C Down	2.5°C Down	2°C Down	1.5°C Down	1°C Down	0.5°C Down	No Change	0.5°C Up	1°C Up	
	56kΩ	4.5°C Down	4°C Down	3.5°C Down	3°C Down	2.5°C Down	2°C Down	1.5°C Down	1°C Down	0.5°C Down	No Change	0.5°C Up	
180kΩ	5°C Down	4.5°C Down	4°C Down	3.5°C Down	3°C Down	2.5°C Down	2°C Down	1.5°C Down	1°C Down	0.5°C Down	No Change		

NOTE: This circuit is designed to input the necessary temperature compensation values into the MICOM. This adjusts the refrigerator temperature, which is different in each model.

8-2-9 Key Button Input & Display Light-On Circuit

▶ The circuit shown above determines whether a function control key on the operation display is pushed. It also turns on the corresponding function indication LED (LED Module) SEVEN SEGMENT DISPLAY (SEVEN SEGMENT DISPLAY MODULE). The drive type is the scan type

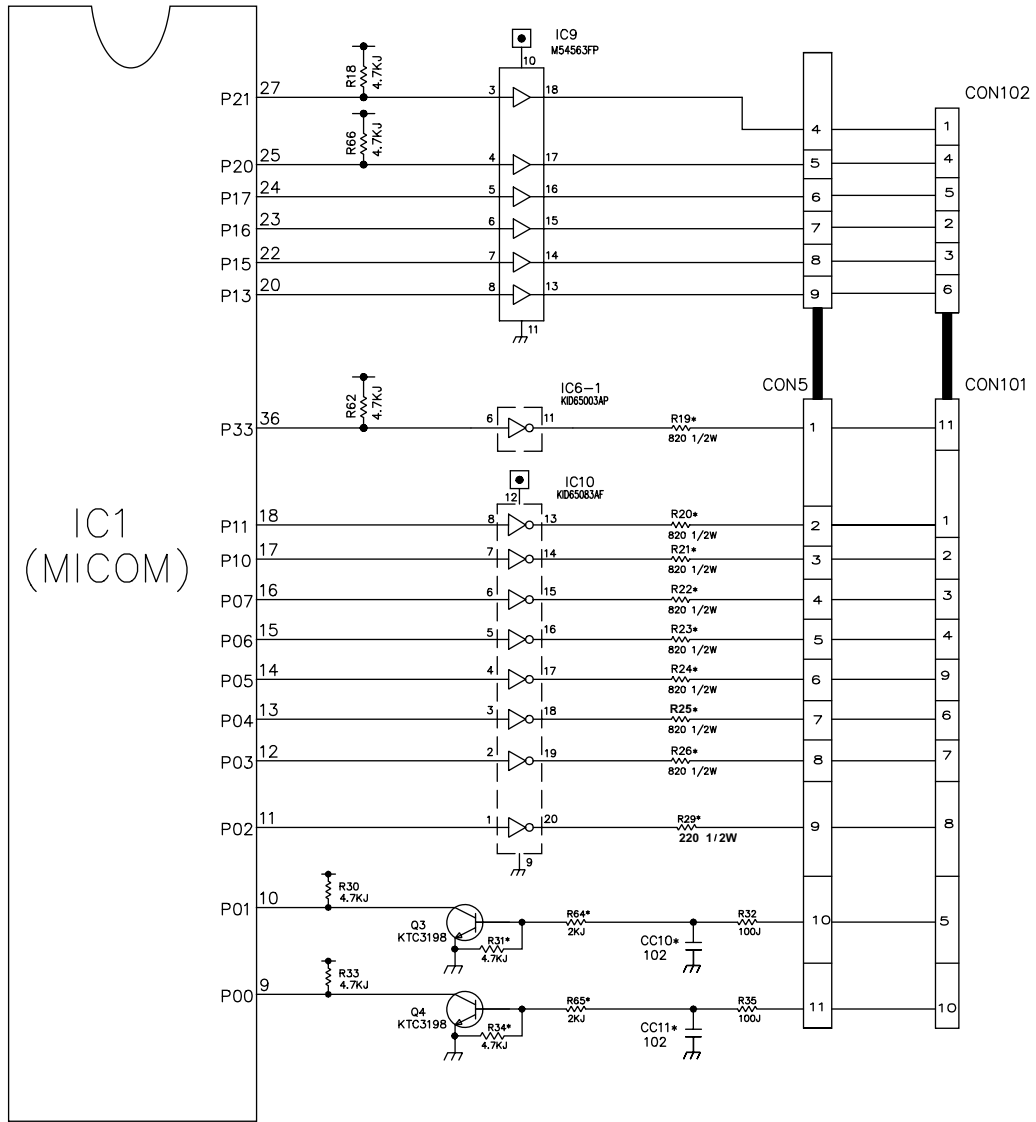

8-2-10 Power Failure Compensation Circuit (DISPENSER MODEL)

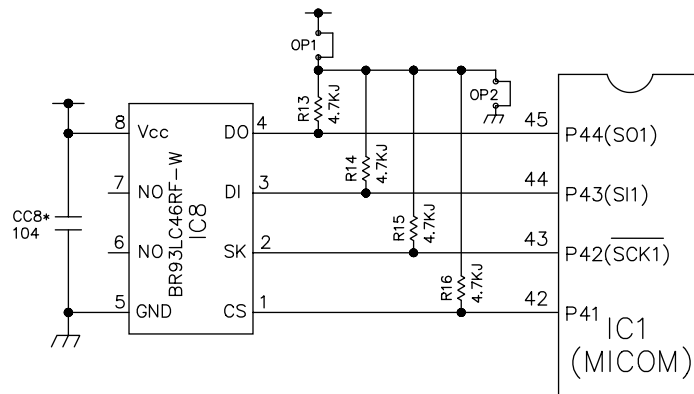

8-3 RESISTANCE SPECIFICATION OF SENSOR

TEMPERATURE DETECTED BY SENSOR	RESISTANCE OF FREEZER SENSOR	RESISTANCE OF REFRIGERATOR & DEFROST SENSOR & ROOM SENSOR
- 20 °C	22.3 KΩ	77 KΩ
- 15 °C	16.9 KΩ	60 KΩ
- 10 °C	13.0 KΩ	47.3 KΩ
- 5 °C	10.1 KΩ	38.4 KΩ
0 °C	7.8 KΩ	30 KΩ
+ 5 °C	6.2 KΩ	24.1 KΩ
+ 10 °C	4.9 KΩ	19.5 KΩ
+ 15 °C	3.9 KΩ	15.9 KΩ
+ 20 °C	3.1 KΩ	13 KΩ
+ 25 °C	2.5 KΩ	11 KΩ
+ 30 °C	2.0 KΩ	8.9 KΩ
+ 40 °C	1.4 KΩ	6.2 KΩ
+ 50 °C	0.8 KΩ	4.3 KΩ

- The resistance of the SENSOR has a $\pm 5\%$ common difference.
- Measure the resistance of the SENSOR after leaving it for over 3 minutes in the measuring temperature. This delay is necessary due to sensor response speed.

8-4 TROUBLESHOOTING

PROBLEM	INDICATED BY	CHECK	CHECKING METHOD	CAUSE	SOLUTION				
POWER SOURCE is poor.	1. The whole DISPLAY LED/SEVEN SEGMENT DISPLAY is off. 2. DISPLAY LED/SEVEN SEGMENT DISPLAY operates abnormally	1. FREEZER/REFRIGERATOR.	Check if FREEZER/REFRIGERATOR DOOR IS OPEN and check display.	POWER SOURCE is poor.	Check outlet Voltage.				
		2. If LAMP is dim.	Check visually.	Applied voltage error.	Use boosting TRANS.				
		3. The connection of the MAIN PWB CONNECTOR.	Check connection of CONNECTOR.	CONNECTOR connection is poor.	Reconnect CONNECTOR.				
COOLING is poor.	NO COOLING.	1. If the COMPRESSOR operate.	USE TEST MODE 1 (forced COOLING). If less than 7 minutes pass after compressor shuts off, don't press the KEY and wait.	TRANS FUSE is open.	Replace TRANS.				
				COMPRESSOR locked or blocked.	Replace COMPRESSOR.				
				OLP, PTC is poor. COMPRESSOR RELAY is poor.	Replace OLP, PTC. Replace MAIN PWB.				
FREEZER TEMPERATURE is incorrect	1. If FAN MOTOR operates.	2. If refrigerant is leaking.	Measure the amount of frost sticking on EVAPORATOR and the surface temperature of the condenser pipe.	THE CONNECTING WIRE is poor.	Check the connection of the black wire of the MAIN PWB CONNECTOR (CON2).				
				Refrigerant leakage.	Replace the leaking part and replace any lost refrigerant.				
				FAN MOTOR is poor.	Replace the FAN MOTOR.				
FREEZER TEMPERATURE is incorrect	1. If FAN MOTOR operates.	2. If DEFROSTING is normal.	Check the amount of frost sticking on the EVAPORATOR.	CONNECTING WIRE is poor.	Certify the MOTOR and the connection of the black wire of the MAIN PWB CONNECTOR (CON2).				
				DEFROSTING is poor.	See DEFROSTING is poor.				
				SENSOR RESISTANCE is poor.	Replace SENSOR.				
				Door liner damaged.	Replace door liner.				
FREEZER TEMPERATURE is incorrect	1. If FAN MOTOR operates.	3. If SENSOR is normal.	Check the resistance of the Refrigerator SENSOR.	Door liner damaged.	Replace door liner.				
						4. Door Line contact.	Check the seal when the door is closed.		
								1. If FAN MOTOR operates.	USE TEST MODE 1 (forced COOLING).
3. If SENSOR is normal.	Check the resistance of the Refrigerator SENSOR.								
		4. Door Line contact.	Check the seal when the door is closed.						

PROBLEM	INDICATED BY	CHECK	CHECKING METHOD	CAUSE	SOLUTION
COOLING is poor.	If REFRIGERATOR TEMPERATURE is too low.	1. If FREEZER TEMPERATURE is normal.	Check is FREEZER TEMPERATURE is too low.		Make sure the DOOR is attached. Replace FAN MOTOR.
		2. If amount of cool air from FAN MOTOR is sufficient.	Make sure that the amount and speed of cool air are sufficient by touching the check supplied on the REFRIGERATOR.	FAN MOTOR is poor. Passage of cool air is blocked. EVA frozen.	Remove impurities. See DEFROSTING is poor.
		3. Door Line contact.	Check door seal when door is closed.	Door liner damaged.	Replace Door liner.
DEFROSTING is poor.	NO DEFROSTING.	1. If HEATER emits heat.	USE TEST MODE2 (forced DEFROSTING).	HEATER disconnection.	Replace HEATER.
				TEMPERATURE FUSE disconnection.	Replace TEMPERATURE FUSE.
				Connection is poor.	Check EVAPORATOR connection and wire of MAIN PWB CONNECTOR.
				DEFROST-SENSOR is poor.	Replace DEFROST-SENSOR.
				HEATER RELAY is poor.	Replace RY3 of MAIN PWB.
				DRAIN PIPE is blocked.	Remove ice and impurities. Check HEATER PLATE resistance.
		2. If DRAIN PIPE is blocked.	Check DRAIN PIPE.		
		3. If ice remains after DEFROSTING.	Make sure that DEFROST SENSOR is connected. Make sure that FREEZER/REFRIGERATOR DOOR is closed.	Connection is poor. DOOR does not close properly.	Reassemble the DEFROST-SENSOR. Reassemble DOOR. Replace GASKET.

8-5-2 Replacement Parts List

No	P/N/O	DESCRIPTION	SPEC	MAKER	REMARK
1	6670_BB087D	PWB(PCB)	KS-PJT BEST	DOO SAN	T-1,6
2	6170_BB2012A	TRANSFORMER, SMPS COIL 1	KS-PJT 220-240V	SAM IL	TRANS
3	6170_BB2012B	TRANSFORMER, SMPS COIL 1	KS-PJT 100-127V	SAM IL	TRANS
4	6630A09106A	CONNECTOR (ICIRC1), WAFER	YK36-03AV	YEON HO	CON2
5	6630A09106B	CONNECTOR (ICIRC1), WAFER	YK396 YEONHO 9P 3.96MM AV	YEON HO	CON2
6	6630A09106H	CONNECTOR (ICIRC1), WAFER	YK396 YEONHO 9P 3.96MM AV	YEON HO	CON3
7	6630_BB007H	CONNECTOR (ICIRC1), WAFER	917787-1 AMP 9P 2.5MM STRAIGHT SN	AMP	CON4
8	6630_BB007A	CONNECTOR (ICIRC1), WAFER	917791-1 AMP 13PIN 2.5MM STRAIGHT SN	AMP	CON5
9	6630_BB007L	CONNECTOR (ICIRC1), WAFER	917790-1 AMP 12P 2.5MM STRAIGHT SN	AMP	CON6
10	6630_BB007C	CONNECTOR (ICIRC1), WAFER	917782-1 AMP 4P 2.5MM STRAIGHT SN	AMP	CON7
11	01SK655100A	IC, SANKEN	STR-6551 5PIN BK SMPS 2,4PIN FORM	SANKEN	IC2
12	01ZZ_BB2024D	IC, DRAWING	TMF870X40AN 64PIN, SDIP BK KS-PJT MASK 1	TOSHIBA	IC11-01ZZ_BB2024R1
13	-	-	-	-	-
14	01PM6NE001A	IC, TOSHIBA	1TL727F 4P BK PHOTO COUPLER	TOSHIBA	IC3
15	01KE431000A	IC, KEC	K1A43L 3 PIN TP - -	KEC	IC4
16	01KE780500W	IC, KEC	K1A7805P1 - - -	KEC	IC5
17	01KE650830B	IC, KEC	K1D6508AE 2050P LED DRIVER	KEC	IC10
18	01KE650030B	IC, KEC	K1D65003AP 16P SDIP BK DRIVE	KEC	IC6
19	01STLM001A	IC, STANDARD LOGIC	M54563P 20 R/TIP CONVERT	MITSUBISHI	IC9
20	01KE704200A	IC, KEC	K1A7042P 3P BK RESET	KEC	IC7
21	01U777400A	IC, TOSHIBA	1A7774AP 16, SDIP BK DRIVE IC STEPPING M	TOSHIBA	IC8
22	01R4934600D	IC, ROHM	R49346GF W SPAN SOP BK EEPROM -	ROHM	IC9
23	000000001A	RELAY	AL16312 MATSUSHITA 12V 16A 15.6V 1A	NAIS	RY2
24	6920AL2001A	RELAY	AL212B12 NAIS 250VAC 16A 12VDC IC NO VENTING	NAIS	-
25	6920_BB2005B	RELAY	G58B-14 250VAC 5A 12VDC IC	OMRON	RY4
26	6920_BB2007A	RELAY	V58-121B TAKAMISAWA DC12V 60MA 250V IC	FUJITSU	RY1
27	6920A90002A	RELAY	ALD112 NAIS1TH(A)DC12V 3A 12V 16.6mA 1A	NAIS	RY3
28	6212_BB001B	RESONATOR, CERAMIC	CST50400M03 MURATA 4MHZ TP	MURATA	RY5
29	6102_BB003A	VARIABLE	INR14D271 ILJIN UL/VDE TP 270V	ILJIN	OSC1
30	6102_BB001B	VARIABLE	INR14D261 ILJIN UL/VDE BK 620V	ILJIN	VA1
31	00R107009AA	DIODE, RECTIFIERS	FR107 TP DELTA D041 1000V 1A 3	DELTA	DI, D2, D5, D6
32	00RS400070A	DIODE, RECTIFIERS	RL2 SANKEN BK NON 400V 2A 40A 50NSEC 10UA	SANKEN	D3, D4
33	00B360000AA	DIODE, RECTIFIERS	D3BAG60 BK SHINDENGEN 600V 4A	SHINDENGEN	BD1
34	6102W5V006A	VARIABLE	INR14D31K ILJIN UL/CSA/VDE BK	ILJIN	VA1
35	0CE476ZV6E0	CAPACITOR, FIXED ELECTROLYTIC	47UF HE 450V 20% BULK SNAP INT1051	SAM WHA	CE1
36	0CE476BK63B	CAPACITOR, FIXED ELECTROLYTIC	47UF KME TYPE 50V 20% FMS TP 5 (11051)	SAM WHA	CE2
37	0CE1076F63B	CAPACITOR, FIXED ELECTROLYTIC	100UF SMS, S6 25V 20% FMS TP 5	SAM WHA	CE12
38	0CE687H4E00	CAPACITOR, FIXED ELECTROLYTIC	680UF RK 250V 20% BULK SNAP INT1051	SAM WHA	CE3
39	0CE687YJ61B	CAPACITOR, FIXED ELECTROLYTIC	680UF RK 35V 0.2 TP 5 FL11051	SAM WHA	CE4
40	0CE227B6F63B	CAPACITOR, FIXED ELECTROLYTIC	220UF KME TYPE 16V 20% FMS TP 5(11051)	SAM WHA	CE5
41	0CE227B6E3B	CAPACITOR, FIXED ELECTROLYTIC	220UF RS TYPE 25V 20% FMS TP 5(11051)	SAM WHA	CE11
42	0CE105BK63B	CAPACITOR, FIXED ELECTROLYTIC	1UF KME TYPE 50V 20% FMS TP 5(11051)	SAM WHA	CE10
43	0CE476BK63B	CAPACITOR, FIXED ELECTROLYTIC	47UF KME TYPE 25V 20% FMS TP 5(11051)	SAM WHA	CE6
44	0CE106EK63B	CAPACITOR, FIXED ELECTROLYTIC	10UF KMG 50V 20% FMS TP 5(11051)	SAM WHA	CE7-CE9
45	00H471K1562	CAPACITOR, FIXED CERAMIC (HIGH DIELECTRIC)	470PF 50V K X7R1X1 1608 R/TP	MURATA	CC1
46	00X2210R61A	CAPACITOR, FIXED CERAMIC (HIGH DIELECTRIC)	250PF D 250V 10% -10% B1V5P1 R/TP	SAM WHA	CC2
47	00X104K94A	CAPACITOR, FIXED CERAMIC (HIGH DIELECTRIC)	100NF 2012 50V R/TP (GRM40X7R104K50PE)	MURATA	CC3-CC7
48	00X102K959	CAPACITOR, FIXED CERAMIC (HIGH DIELECTRIC)	1000PF 50V K B T AS2	MURATA	CC17
49	00X2230K96A	CAPACITOR, FIXED CERAMIC (HIGH DIELECTRIC)	22NF 2012 50V 80%, -20% R/TP X7R	MURATA	CC16, CC18, CC19
50	00X2230K949	CAPACITOR, FIXED CERAMIC (HIGH DIELECTRIC)	22NF 50V Z F AS2	MURATA	CC12-CC15
51	00X102K96A	CAPACITOR, FIXED CERAMIC (HIGH DIELECTRIC)	1NF 2012 50V 80%, -20% R/TP X7R	MURATA	CC10
52	00C47418670	CAPACITOR, FIXED FILM	0.47UF D 275V M/PP NI R	PILKOR	CM1, CM2
53	00F22408670	CAPACITOR, FIXED FILM	220NF O 275V 20% BULK M/PP NI	PILKOR	-
54	00A47321430	CAPACITOR, FIXED FILM	47000PF S 630V -10%PE NI R	SAM WHA	CM3
55	00C2241E630	CAPACITOR, FIXED FILM	0.22UF D 100V M/PP NI R	SAM WHA	CM4
56	00C2231N409	CAPACITOR, POLYESTER	0.022UF D 100V J PE TP	SAM WHA	CM5
57	OR_2200H672	RESISTOR, METAL GLAZED (CHIP)	220 OHM 1/2 W 5%, 2012 R/TP	SMART, CHOHYANG	R29
58	OR51503J609	RESISTOR, FIXED METAL OXIDE FILM	150K OHM 1W 5.00% TA52	SMART, CHOHYANG	R1
59	OR58202609	RESISTOR, FIXED METAL OXIDE FILM	82K OHM 1W 5.00% TA52	SMART, CHOHYANG	R1
60	OR50101J609	RESISTOR, FIXED METAL OXIDE FILM	1 OHM 1 W 5.00% TA52	SMART, CHOHYANG	ROCP
61	OR50470J609	RESISTOR, FIXED METAL OXIDE FILM	0.47 OHM 1 W 5.00% TA52	SMART, CHOHYANG	ROCP
62	OR55502K641	RESISTOR, FIXED METAL OXIDE FILM	56K OHM 2 W 5.00% TA52	SMART, CHOHYANG	R3
63	OR_8200H672	RESISTOR, METAL GLAZED (CHIP)	820 OHM 1/2 W 5%, 2012 R/TP	SMART, CHOHYANG	R19-R26
64	OR05010H609	RESISTOR, FIXED CARBON FILM	560K OHM 1/2 W 5.00% TA52	SMART, CHOHYANG	R19
65	OR05010H609	RESISTOR, FIXED CARBON FILM	1.5K OHM 1/2 W 5.00% TA52	SMART, CHOHYANG	R48
66	OR01000G609	RESISTOR, FIXED CARBON FILM	100 OHM 1/4 W 5.00% TA52	SMART, CHOHYANG	R32
67	OR_2200L622	RESISTOR, METAL GLAZED (CHIP)	220 OHM 1/8 W 2012 5.00% D	ROHM	R36
68	ORH4701L622	RESISTOR, METAL GLAZED (CHIP)	4.7K OHM 1/8 W 2012 5.00% D	ROHM	R10, R12, R44, R31, R18
69	ORH002L622	RESISTOR, METAL GLAZED (CHIP)	10K OHM 1/8 W 2012 5.00% D	ROHM	R34
70	OR_0332E672	RESISTOR, FIXED CARBON FILM	33 OHM 1/8 W 5%, 2012 R/TP	SMART, CHOHYANG	R46
71	OR01001G609	RESISTOR, FIXED CARBON FILM	1K OHM 1/4 W 5.00% TA52	SMART, CHOHYANG	R5
72	ORH1001L622	RESISTOR, METAL GLAZED (CHIP)	1K OHM 1/8 W 2012 5.00% D	ROHM	R9
73	OR_2001L622	RESISTOR, METAL GLAZED (CHIP)	2K OHM 1/8 W 2012 5.00% D	ROHM	R55, R64, R36-R39
74	OR02001G609	RESISTOR, FIXED CARBON FILM	2K OHM 1/4 W 5.00% TA52	SMART, CHOHYANG	R55
75	OR_0330L622	RESISTOR, METAL GLAZED (CHIP)	330 OHM 1/8 W 2012 5.00% D	ROHM	R40, R49, R51, R52, R56
76	ORH1004L622	RESISTOR, METAL GLAZED (CHIP)	1M OHM 1/8 W 2012 5.00% D	ROHM	R47
77	ORH6226409	RESISTOR, FIXED CARBON FILM	16.2K OHM 1/4 W 1.00% TA52	SMART, CHOHYANG	R11
78	ORH2612409	RESISTOR, FIXED CARBON FILM	26.1K OHM 1/4 W 1.00% TA52	SMART, CHOHYANG	RF1
79	OR03501G609	RESISTOR, FIXED CARBON FILM	3.9K OHM 1/4 W 5.00% TA52	SMART, CHOHYANG	RF1, RF1
80	OR04701G609	RESISTOR, FIXED CARBON FILM	4.7K OHM 1/4 W 5.00% TA52	SMART, CHOHYANG	R45
81	OR_6800E672	RESISTOR, METAL GLAZED (CHIP)	680 OHM 1/8 W 5%, 2012 R/TP	SMART, CHOHYANG	R4, R30, R33, R50, R57-R62, R66
82	OR01002G609	RESISTOR, FIXED CARBON FILM	10K OHM 1/4 W 5.00% TA52	SMART, CHOHYANG	R13-R16, R53
83	ORH010L622	RESISTOR, METAL GLAZED (CHIP)	1.0K OHM 1/8 W 2012 5.00% D	ROHM	R6
84	OR02702G609	RESISTOR, FIXED CARBON FILM	27K OHM 1/4 W 5.00% TA52	SMART, CHOHYANG	R17, RCR1, R41-R43
85	OR04702G609	RESISTOR, FIXED CARBON FILM	47K OHM 1/4 W 5.00% TA52	SMART, CHOHYANG	R7
86	OR_910E472	RESISTOR, FIXED METAL FILM	9.1K OHM 1/8 W 1%, 2012 R/TP	ROHM	-
87	OR_240E472	RESISTOR, FIXED METAL FILM	2.4K OHM 1/8 W 1%, 2012 R/TP	ROHM	RL1
88	OR_270E672	RESISTOR, METAL GLAZED (CHIP)	270 OHM 1/8 W 2012 5.00% D	ROHM	RL2
89	OTRKE00098A	TRANSISTOR, BIPOLAR	KEC K1B151 BK 10126 60V 5A	KEC	RS4
90	OTR319809AA	TRANSISTOR	KTC3198-TP-Y (KTC1B151)KEC	KEC	OS, OS6
91	OTRKE80016A	TRANSISTOR, BIPOLAR	KEC KR6105 R/TP S0123 50V 100MA	KEC	O1
92	OTR106009AC	TRANSISTOR, BIPOLAR	KRA 106M KEC	KEC	O7
93	-	-	-	-	-
94	6210_BB001A	SIL, THER (CIRC), EMC	BF5350AD SAMMHA 52	SAM WHA	FBI
95	6600R1001Z	SIL, THER (CIRC), EMC	J1P123046 JEIL 12V DC 50MA	JEIL	SM1
96	6854B50001A	JUMP WIRE	0.6MM 52MM TP TAPING SNT10MM	DAE A LEAD	J01-J04, J06-J13, J14, J01
97	6854B50001A	JUMP WIRE	0.6MM 52MM TP TAPING SNT10,5MM	DAE A LEAD	J05
98	6854B50001A	JUMP WIRE	0.6MM 52MM TP TAPING SNT10MM	DAE A LEAD	OPI
99	6854B50001A	JUMP WIRE	0.6MM 52MM TP TAPING SNT10MM	DAE A LEAD	OP2, OP3, R13-R16
100	6200_BB004A	FILTER (CIRC), EMC	CV940050 TNC BK	TNC	L1
101	6200_BB007X	FILTER (CIRC), EMC	UV11-05320 TNC BK 0.5A 32MH	TNC	L2
102	OLR001M4F0	INDUCTOR, RADIAL LEAD	1000UH 20% R 5X12.5 BULK	TNC	L3
103	0F18001E521	FUSE, FAST BLOW	9300MA 250V 6.3X31.8 CY/GL KS	SAM JU	FUSE1
104	6901_BB001A	FUSE ASSEMBLY	KORE-PTJ N'S	SAM JU	FUSE HOLDER
105	0FZZ_BB3001A	FUSE, DRAWING	2A 250V SLOW-BLOW LITTLE FUSE, TRIAD	SAM JU	FUSE1
106	6908_BB3002F	BUZZER	0E2228P DAE YOUNG PE20 2W 755(OHMA)	DAE YOUNG	BUZZER
107	4920_BB3007A	HEAT SINK	23.3*17*25 DRIVE IC STR	-	(IC2)
108	158F0302418	SCREW TAP TITE (S), BINDING HE	+03.0 LB. 0 MSWR3/FZY	SHAN	(IC2)
109	9WIF0120000	SOLDER (ROSN WIRE) R50	DI.20	-	-
110	49H1004	SOLDER, SOLDERING	H63A	HISUNG	-
111	59333105	FLUX	SG101.825-0.830 KOREA F.H-206	KOKI	-
112	00C03H609	CAPACITOR, FIXED FILM	0.01UF D 100V 10% PE 1P5	SAM WHA	CM4

8-5-3 PWB Assembly, Display, And Parts List

Dispenser Model

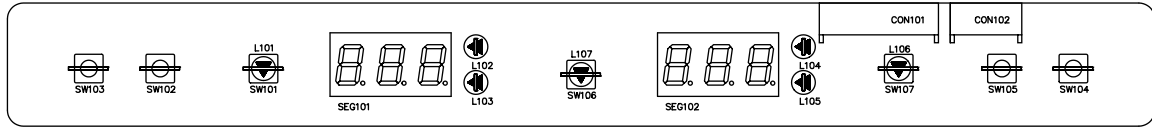

No	P/NO	DESCRIPTION	SPEC	MAKER	REMARK
1	6870JB8090A	PWB(PCB)	KS-PJT DISPENSER DISPLAY	DDO SAN	-
2	-	-	-	-	-
3	6630JB8005D	WAFER	SMAW250-11	YEON HO	CON101
4	6630JB8004U	WAFER	SMAW250-06	YEON HO	CON102
5	6600JB8005A	SWITCH,TACT	KPT-1105A	KYUNG IN	SW102~105
6	6600RRT002K	SWITCH,TACT	JTP1230A JEIL 12V DC 50MA	JEIL	SW102~105
7	6600JB8004A	TACT S/W	KPT-1109R	KYUNG IN	SW101,SW107
8	-	TACT S/W	KPT-1109G	KYUNG IN	SW106
9	6327JB8001A	DISPLAY LED ASSEMBLY	LN4023-13EWRS GREEN 2.1V 1.7MCD	LEDTECH	SEG1,SEG2
10	0DLLE0059AA	LED	LT8323-41-BCN 2.1V D3 TP GREEN	LEDTECH	L102~105
11	0DD414809AA	DIODE,SWITCHING	1N4148 26MM	PYUNG CHANG	D107~113
12	0DD400400A	DIODE,SWITCHING	1N4004	DELTA	D101~106
13	6854B50001A	JUMP WIRE	0.6MM 52MM TP TAPING SN(10MM)	-	J01~06,J08~13
14	9VWF0120000	SOLDER<ROSIN WIRE> RSO	D1.20	HEE SUNG	-
15	49111004	SOLDER,SOLDERING	H63A	-	-
16	59333105	FLUX	SGJ0.825-0.830 KOREA F.H-206	KOKI	-

Best Model

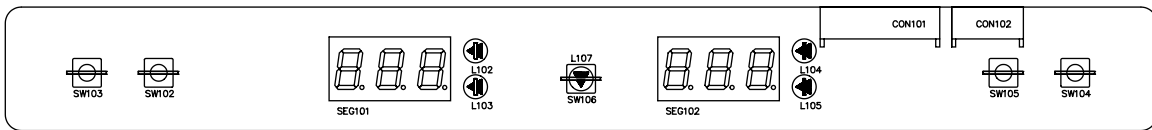

No	P/NO	DESCRIPTION	SPEC	MAKER	REMARK
1	6870JB8090A	PWB(PCB)	KS-PJT DISPENSER DISPLAY	DDO SAN	-
2	-	-	-	-	-
3	6630JB8005D	WAFER	SMAW250-11	YEON HO	CON101
4	6630JB8004U	WAFER	SMAW250-06	YEON HO	CON102
5	6600JB8005A	SWITCH,TACT	KPT-1105A	KYUNG IN	SW102~105
6	6600RRT002K	SWITCH,TACT	JTP1230A JEIL 12V DC 50MA	JEIL	SW102~105
7	6600JB8004A	TACT S/W	KPT-1109R	KYUNG IN	SW101,SW107
8	-	TACT S/W	KPT-1109G	KYUNG IN	SW106
9	6327JB8001A	DISPLAY LED ASSEMBLY	LN4023-13EWRS GREEN 2.1V 1.7MCD	LEDTECH	SEG1,SEG2
10	0DLLE0059AA	LED	LT8323-41-BCN 2.1V D3 TP GREEN	LEDTECH	L102~105
11	0DD414809AA	DIODE,SWITCHING	1N4148 26MM	PYUNG CHANG	D107~113
12	0DD400400A	DIODE,SWITCHING	1N4004	DELTA	D101~106
13	6854B50001A	JUMP WIRE	0.6MM 52MM TP TAPING SN(10MM)	-	J01~06,J08~13
14	9VWF0120000	SOLDER<ROSIN WIRE> RSO	D1.20	HEE SUNG	-
15	49111004	SOLDER,SOLDERING	H63A	-	-
16	59333105	FLUX	SGJ0.825-0.830 KOREA F.H-206	KOKI	-

8-6 PWB DIAGRAM

8-6-1 PWB Main Assembly

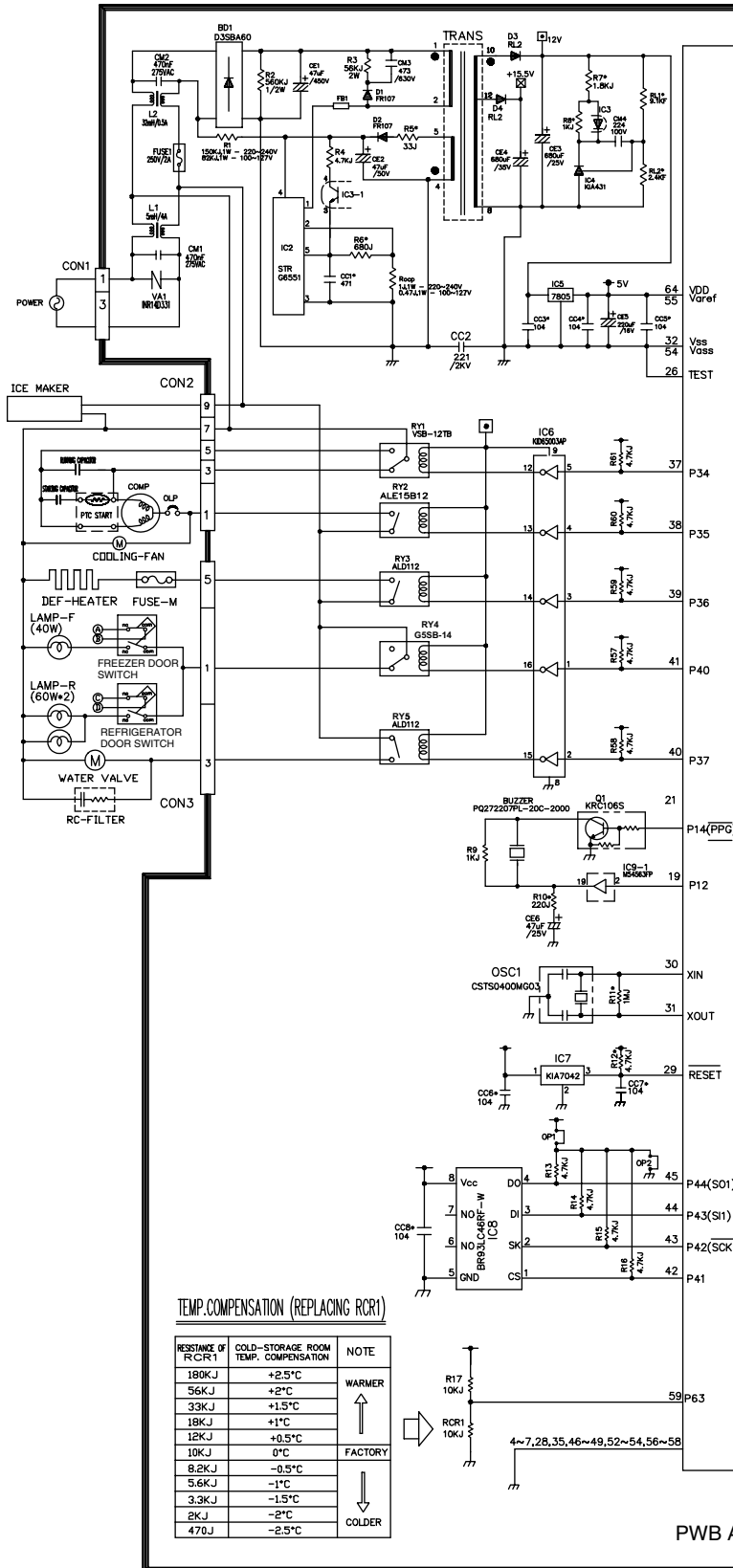

TOSHIBA TMP87C840N(1C1)

PWB ASSEMBLY

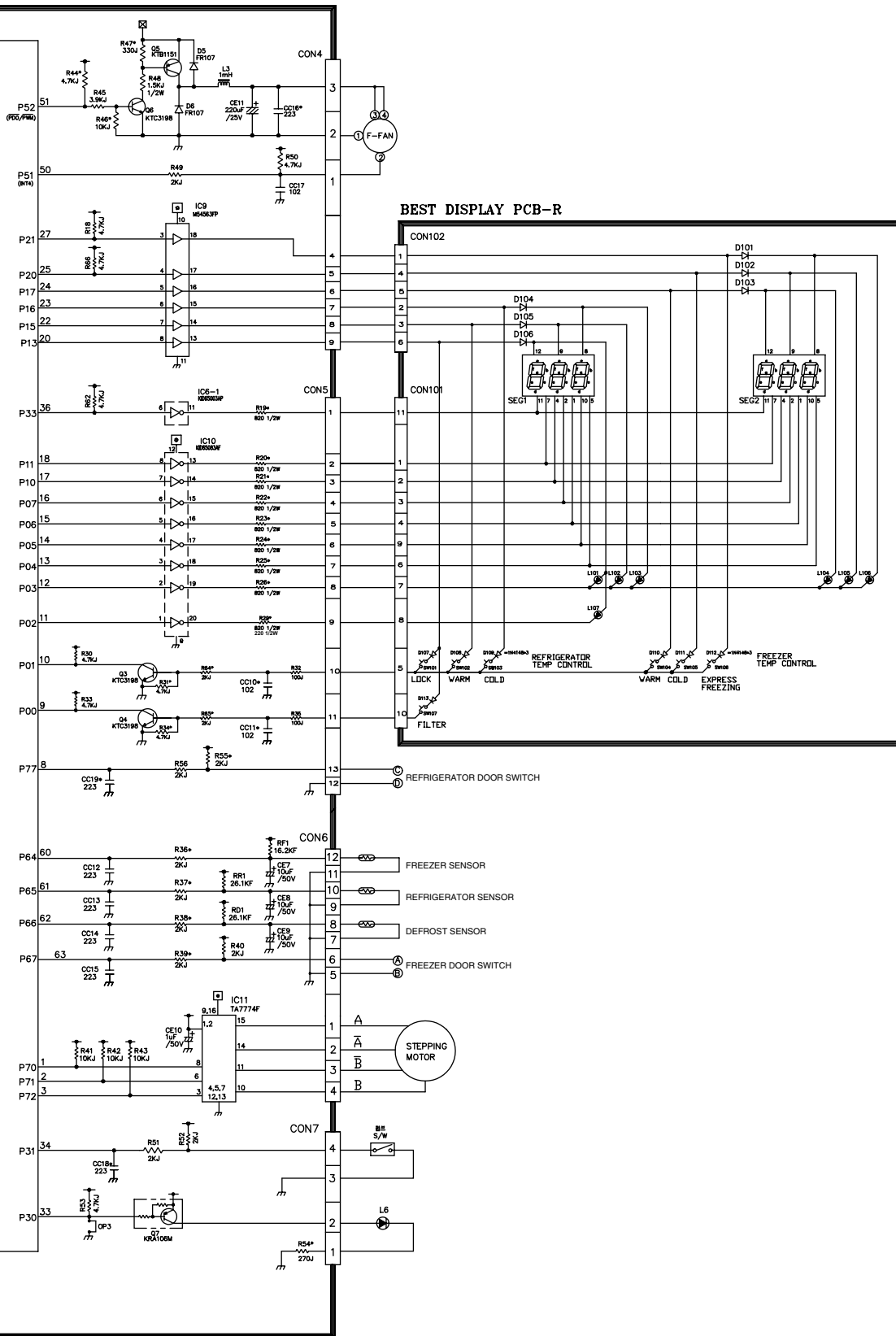

9. DESCRIPTION OF FUNCTION & CIRCUIT OF MICOM

9-1 FUNCTION

9-1-1 Function

1. When the appliance is plugged in, it is set to "4" for Refrigerator and "4" for freezer.
You can adjust the Refrigerator and the Freezer control temperature by pressing the ADJUST button.
2. When the power is initially applied or restored after a power failure, it is automatically set to "4" & "4".

BETTER / GOOD MODEL

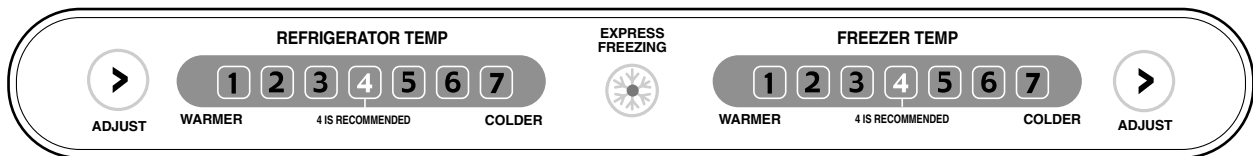

9-1-2 Control of freezer fan motor

1. Freezer fan motor has high and standard RPMs.
2. High RPM is used when electricity is first on, for express freezing, and when refrigerator is overloaded.
But standard RPM is used for general purposes.
3. To improve cooling speed and load corresponding speed, the RPM of freezer fan motor shall change from normal speed to high speed.
4. High speed (2500RPM) : Initial power on or load corresponding operation, express freezing Normal speed (2200RPM) : General working conditions.
5. Fan motor stops when refrigerator or freezer door opens.

9-1-3 EXPRESS FREEZING

1. The purpose of this function is to intensify the cooling speed of freezer and to increase the amount of ice.
2. Whenever selection switch is pressed, selection/release, the LED will turn ON or OFF.
3. If there is a power cut and the refrigerator is power on again, EXPRESS FREEZING function will be canceled.
4. To activate these function you need to press the Express Freezing key and the LED will turn ON. This function will remain activated for 24 hrs. The first three hours the compressor and Freezer Fan will be ON. The next 21 hours the freezer will be controlled at the lowest temperature. After 24 hours or if the Express Freezing key is pressed again, the freezer will return to its previous temperature.
5. For the first three hours notice the following cases:
 - (1) Compressor and freezer fan(HIGH RPM) continuously operate for three hours.
 - (2) If defrost starts during EXPRESS FREEZING, EXPRESS FREEZING operates for the rest of time after defrost is completed, when EXPRESS FREEZING operation time is less than 90 minutes.
If EXPRESS FREEZING operates for more than 90 minutes, the EXPRESS FREEZING will operate for two hours after defrost is completed.
 - (3) If EXPRESS FREEZING is pressed during defrost, EXPRESS FREEZING LED is on but this function will start seven minutes after defrost is completed and it shall operate for three hours.
 - (4) If EXPRESS FREEZING is selected within seven minutes after compressor has stopped, the compressor (compressor delays seven minutes) shall start after the balance of the delay time.
 - (5) The fan motor in the freezer compartment rotates at high speed during EXPRESS FREEZING.
6. For the rest of 21 hours, the freezer will be controlled at the lowest temperature.

9-1-4. REFRIGERATOR LAMP AUTO OFF

1. To protect the risk of lamp heat, when Refrigerator door opens for 7 min., refrigerator lamp is auto off.

9-1-5 Alarm for Open Door

1. This feature sounds a buzzer when the freezer or refrigerator door is not closed within 1 minute after it is opened.
2. One minute after the door is opened, the buzzer sounds three times each for 1/2 seconds. These tones repeat every 30 seconds.
3. The alarm is cancelled when the freezer or the refrigerator is closed while the buzzer sounds.

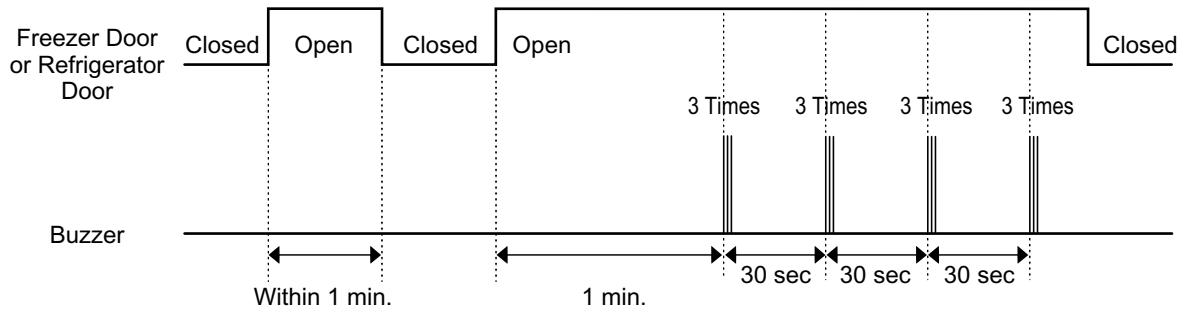

9-1-6 Buzzer Sound

When the button on the front Display is pushed, a Ding~ Dong~ sound is produced.
(Refer to the Buzzer Circuit 7-2-4 No. 2)

9-1-7 Defrosting (removing frost)

1. Defrosting starts each time the COMPRESSOR running time reaches 7 hours.
2. For initial power on or for restoring power, defrosting starts when the compressor running time reaches 4 hours.
3. Defrosting stops if the sensor temperature reaches 46.4°F(8°C) or more. If the sensor doesn't reach 46.4°F(8°C) in 2 hours, the defrost mode is malfunctioning. (Refer to the defect diagnosis function, 7-1-9.)
4. Defrosting won't function if its sensor is defective (wires are cut or short circuited)

9-1-8 Electrical Parts Are Turned On Sequentially

Electrical parts such as COMP, defrosting heater, freezer FAN, etc. are turned on in the following order to prevent noise and parts damage. Several parts are started at the same time at initial power on and are turned off together when TEST is completed.

OPERATING		ORDERS				
Initial power on	Temperature of Defrosting Sensor is 45°C or more (when unit is newly purchased or when moved)	POWER ON	in 1/2 second →	COMP ON	in 1/2 second →	Freezer FAN ON
	Temperature of defrosting sensor is lower than 45°C (when power cuts, SERVICE)	POWER ON	in 1/2 second →	Defrosting heater ON	in 10 second →	Defrosting heater OFF
		in 1/2 second →	COMP ON	in 1/2 second →	Freezer FAN ON	
	Reset to normal operation from TEST MODE	Total load OFF	in 7 minute →	COMP ON	in 1/2 second →	Freezer FAN ON

9-1-9 Defect Diagnosis Function

1. Automatic diagnosis makes servicing the refrigerator easy.
2. When a defect occurs, the buttons will not operate; but the tones. such as ding. will sound.
3. When the defect CODE removes the sign, it returns to normal operation (RESET).
4. The defect CODE shows on the Refrigerator and Freezer Display.

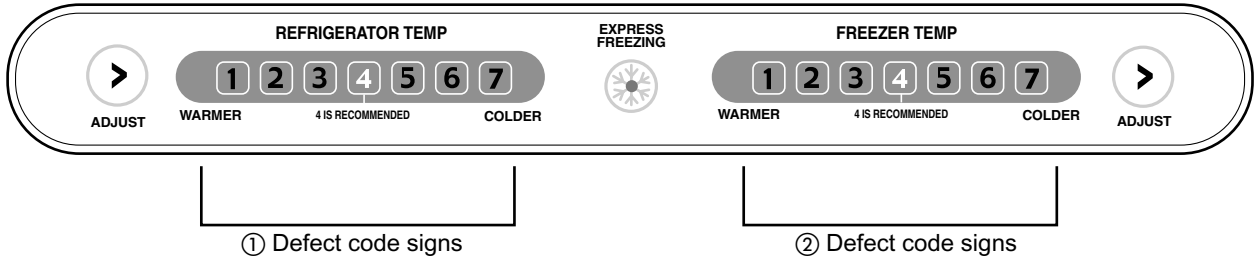

ERROR CODE on display panel

● LED OFF

○ LED ON

NO	ITEM	ERROR CODE		CONTENTS	REMARKS
		①	②		
1	Failure of freezer sensor	All off	● ○ ○ ○ ○ ○ ○ ○	Cut or short circuit wire	Inspect Connecting wires on each sensor
2	Failure of Refrigerator sensor	All off	○ ● ○ ○ ○ ○ ○ ○	Cut or short circuit wire	
3	Failure of defrost sensor	All off	○ ○ ● ○ ○ ○ ○ ○	Cut or short circuit wire	
4	Poor of defrost	All off	● ● ● ● ○ ○ ○	2hours later After starting defrost, If sensor doesn't be over 46°F (8°C)	Snapping of defrost heater or Temperature fuse, pull-out of Connector (indicated minimum 2 Hours after failure occurs)

9-1-10 TEST Mode

1. The Test mode allows checking the PCB and the function of the product as well as finding out the defective part in case of an error.
2. The test mode is operated by pressing two buttons at Display panel.
3. While in the test mode, the function control button is not recognized, but the recognition tone (beep~) sounds.
4. After exiting the test mode, be sure to reset by unplugging and then plugging in the appliance.
5. If an error, such as a sensor failure, is detected while in the test mode, the test mode is cleared and the error code is displayed.
6. While an error code is displayed, the test mode will not be activated.

MODE	MANIPULATION	CONTENTS	REMARKS
TEST1	Push Express Freezing key and COLDER KEY of Freezer Temp. at the same time over 3 seconds.	<ol style="list-style-type: none"> 1. Continuous operation of the COMPRESSOR 2. Continuous operation of the freezer fan 3. STEPPING DAMPER OPEN 4. Defrosting Heater OFF 5. Every DISPLAY LED ON 	
TEST2	Push Express Freezing key and COLDER KEY of Freezer Temp. at the same time over 3 seconds in TEST MODE 1	<ol style="list-style-type: none"> 1. COMP OFF 2. Freezer FAN OFF 3. STEPPING DAMPER CLOSE 4. Defrosting heater ON 5. DISPLAY LED 1, 3, 5, 7 ON 	Reset if the temperature of the Defrosting sensor is 46°F (8°C) or more.
Reset	Push Express Freezing key and COLDER KEY of Freezer Temp. at the same time over 3 seconds. in TEST MODE 2	Reset to the previously setting before TEST MODE	The compressor will Start after a 7-minute delay.

NOTE : LED CHECK MODE: When the refrigerator temperature control and the freezer temperature control button at the same time are hold for 1 second or longer, every LED on the display turns on at the same time. when the button are released, the previous mode is restored.

* Freezer Fan RPM Variable Check:

In case the freezer fan is in operation when the WARMER KEY in Refrigerator and Freezer Temp. Control are pressed for more than one second at the same time freezer fan RPM changes. (for example if high speed, to normal speed or if normal speed, to high speed for 30 seconds)
After 30 seconds, it turns to its original RPM.

* Demonstration MODE:

1. When the KEY of refrigerator Temp. control or of freezer Temp. control is pushed and held over 5 seconds, warmest temperature's It converts to Demonstration Mode.
2. In this status, each LED is rotated with 1 second interval.
3. In this status, all Loads are off (Compressor / Fan / Damper / Heater)
(Even is Demonstration Mode, the refrigerator Lamp automatic off function works normally and can be demonstrated)
4. It reset if you do again as clause.

9-2 PCB FUNCTION

9-2-1 Power Circuit

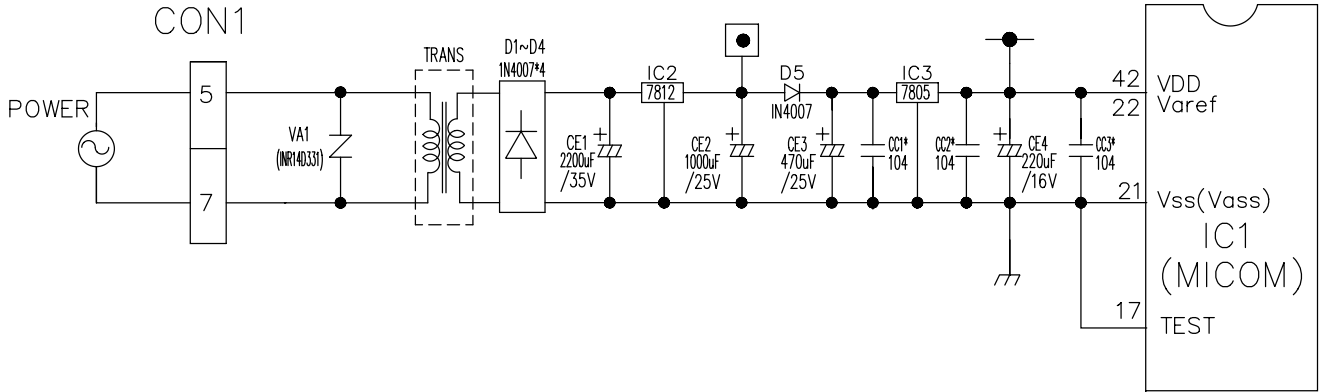

The secondary part of the TRANSFORMER is composed of the power supply for the display, the BLDC FAN Motor drive (15.5 V), the relay drive (12 Vdc) and the MICOM and IC (5 Vdc).

The voltage for each part is as follows:

PART	VA 1	CE 2	CE 1	CE 4
VOLTAGE	115 Vac	12 Vdc	15.5 Vdc	5 V

VA1 is a part for preventing over voltage and noise. When 385V or higher power is applied, the inside elements are short-circuited and broken, resulting in blowout of the fuse in order to protect the elements of the secondary part of the TRANSFORMER.

9-2-2 Oscillation Circuit

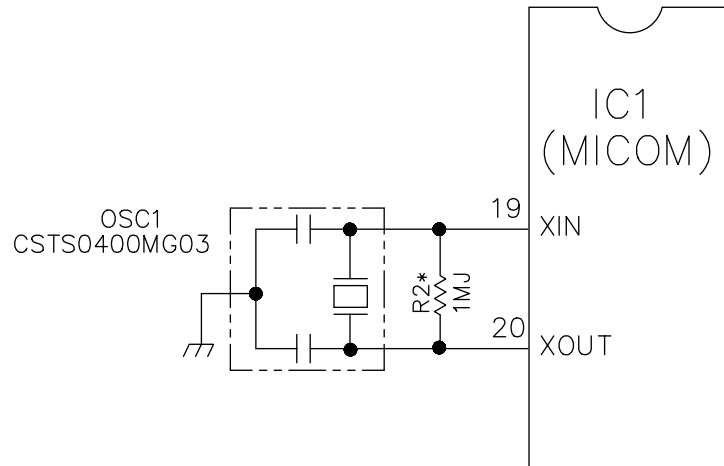

This circuit generates the base clock for calculating time and the synchro clock for transmitting data from and to the inside logic elements of the IC1 (MICOM). Be sure to use specific replacement parts, since calculating time by the IC1 may be changed. If changed, the OSC1 SPEC will not work.

9-2-3 Reset Circuit

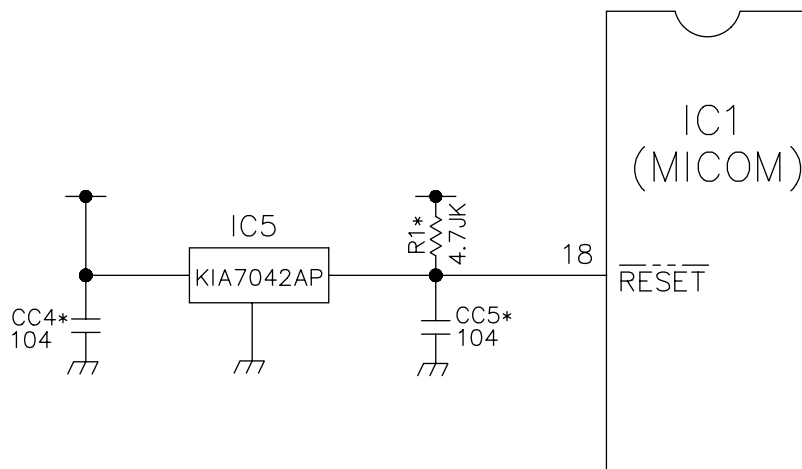

The RESET circuit allows all the functions to start at the initial conditions by initializing various parts, including the RAM inside the MICOM (IC1) when the power is initially supplied or the power supply to the MICOM is restored after a momentary power failure. For the initial 10ms of power supply, LOW voltage is applied to the MICOM RESET terminal. During a normal operation, 5V is applied to the RESET terminal. (If a malfunction occurs in the RESET IC, the MICOM will not operate.)

9-2-4 Load / Buzzer Drive & Open Door Detection Circuit

1. Load Drive Condition Check

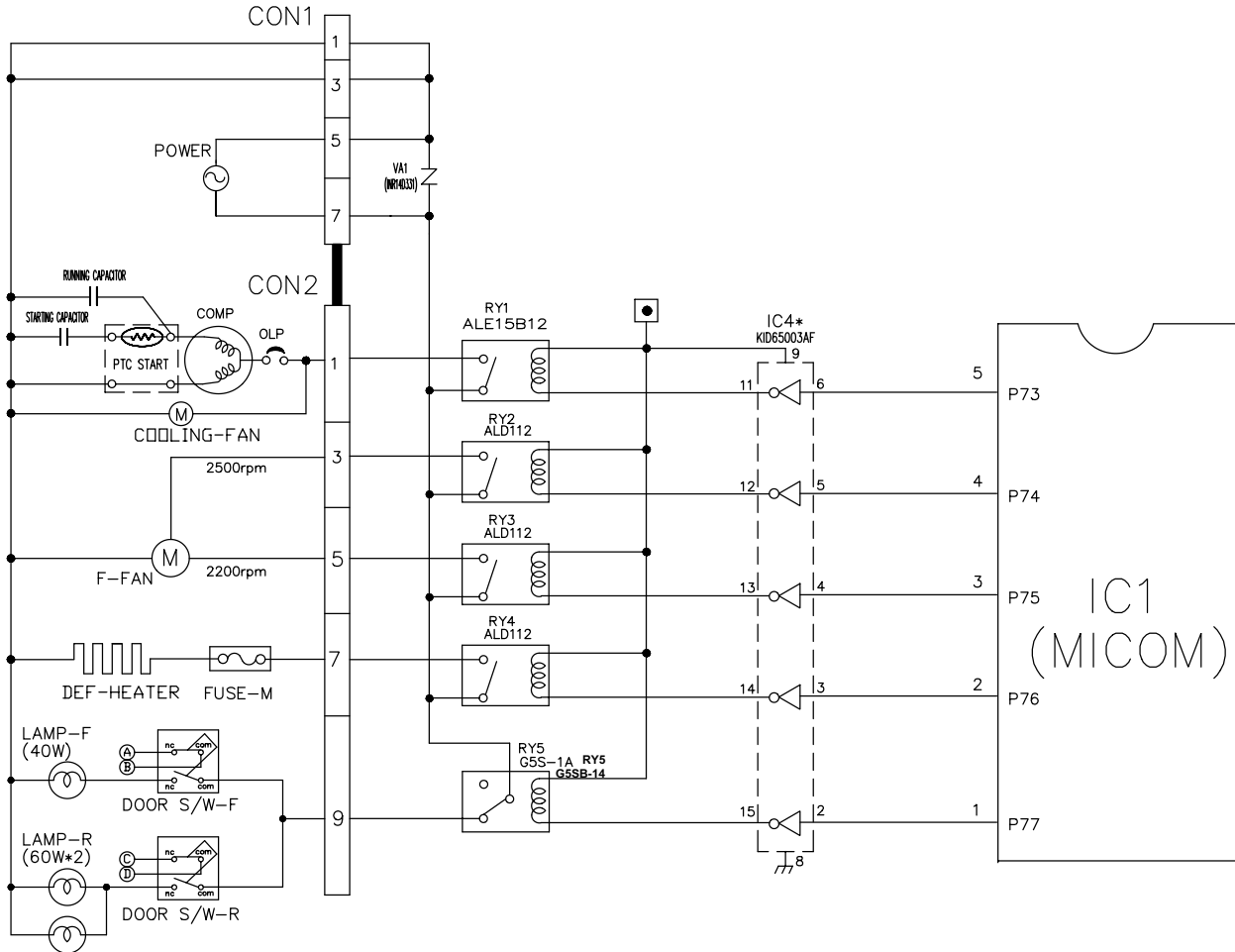

LOAD TYPE		COMP	DEFROSTING HEATER	LAMP	FREEZER FAN MOTOR (HIG RPM)	FREEZER FAN MOTOR (LOW RPM)
Measurement Location (IC4)		NO.11	NO.14	NO.15	NO.12	NO.13
Condition	ON	1V or below				
	OFF	12V				

2. Buzzer Drive Condition Check

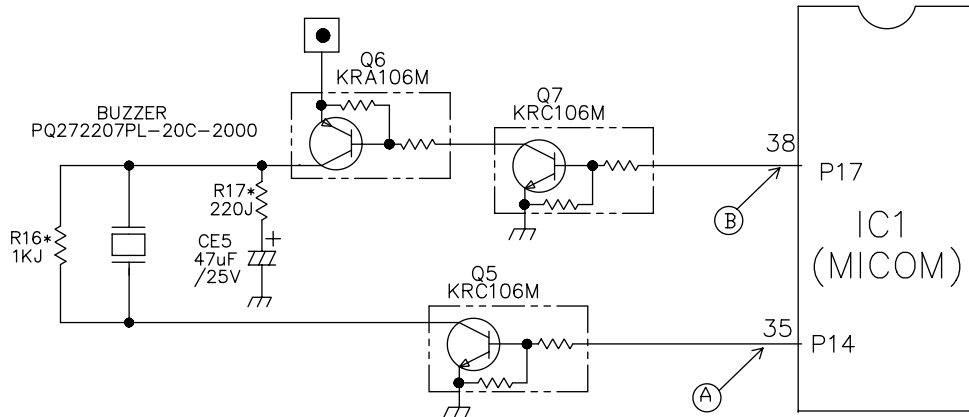

Condition Measurement Location	Tone (Ding~Dong~) when the button on the display is pushed.	Alarm for open door (beep-beep-beep)	OFF
IC1 (A)			0 V
IC1 (B)			0 V

3. Open Door Detection Circuit Check

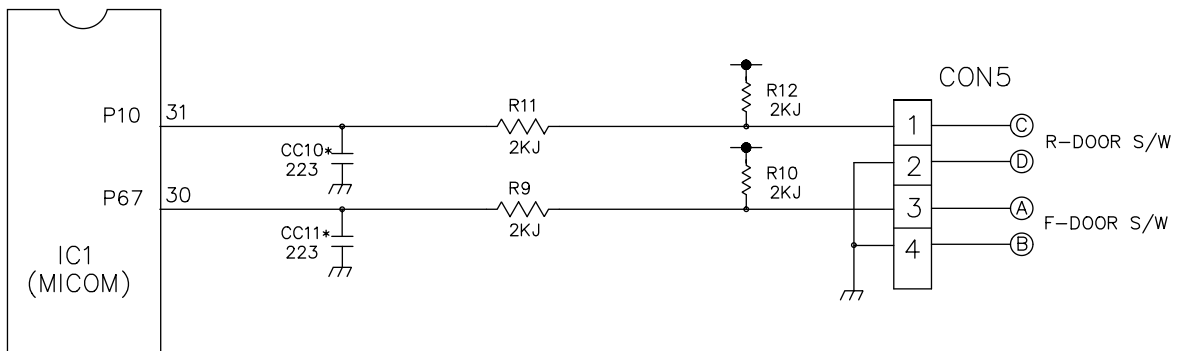

Measurement Freezer/ Refrigerator Door	(PIN NO.31 & PIN NO.30)
Closed	5 V
Open	0 V

9-2-5 Temperature Sensor Circuit

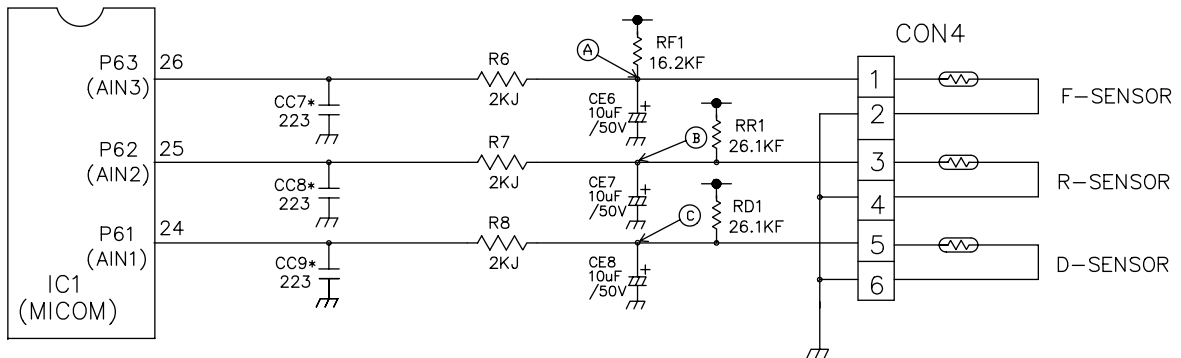

The upper CIRCUIT reads REFRIGERATOR temperature, FREEZER Temperature, and DEFROST-SENSOR temperature for defrosting and the indoor temperature for compensating for the surrounding temperature into MICOM. OPENING or SHORT state of each TEMPERATURE SENSOR are as follows:

SENSOR	CHECK POINT	NORMAL (-30°C ~ 50°C)	SHORT-CIRCUITED	OPEN
Freezer Sensor	POINT (A) Voltage	0.5 V ~ 4.5 V	0 V	5 V
Refrigerator Sensor	POINT (B) Voltage			
Defrosting Sensor	POINT (C) Voltage			

9-2-6 Refrigeration Compartment Stepping Motor Damper Circuit

* The circuit shown below is the damper circuit to regulate the refrigerator temperature.

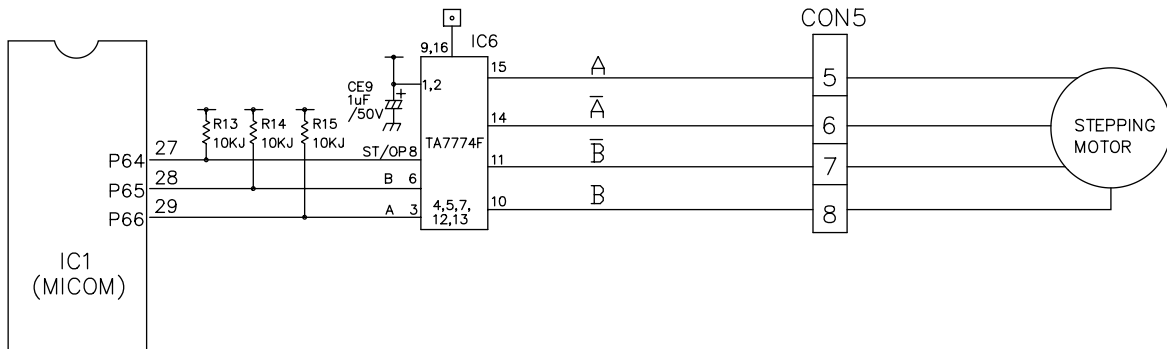

9-2-7 Temperature Compensation & Overcooling/Undercooling Compensation Circuit

1. Refrigerator Temperature Compensation

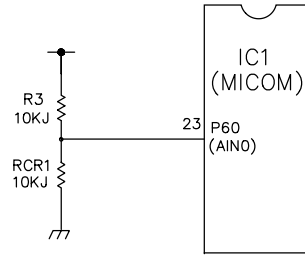

Refrigerator		Remark
Resistance (RCR)	Temperature Compensation	
180 KΩ	+2.5°C	Compensation by raising the temperature ↑
56 KΩ	+2.0°C	
33 KΩ	+1.5°C	
18 KΩ	+1.0°C	
12 KΩ	+0.5°C	
10 KΩ	0 °C	Standard Temperature
8.2 KΩ	-0.5°C	Compensation by lowering the temperature ↓
5.6 KΩ	-1.0°C	
3.3 KΩ	-1.5°C	
2 KΩ	-2.0°C	
470 Ω	-2.5°C	

◆ Table of Temperature Compensation by adjusting the resistance (difference from the current temperature) e.g., If the refrigerator compensation resistance (RCR) is changed from 10K (the current resistance) to 18K (the adjustment resistance), the temperature of the refrigerator rises 33.8°F(+1°C).

2. The temperature compensation for refrigerator compartment is in the following table:

		Revised resistance	470Ω	2kΩ	3.3kΩ	5.6kΩ	8.2kΩ	10kΩ	12kΩ	18kΩ	33kΩ	56kΩ	180kΩ
		Present resistance											
Refrigerator (RCR)	470Ω	No change	0.5°C Up	1°C Up	1.5°C Up	2°C Up	2.5°C Up	3°C Up	3.5°C Up	4°C Up	4.5°C Up	5°C Up	
	2kΩ	0.5°C Down	No Change	0.5°C Up	1°C Up	1.5°C Up	2°C Up	2.5°C Up	3°C Up	3.5°C Up	4°C Up	4.5°C Up	
	3.3kΩ	1°C Down	0.5°C Down	No Change	0.5°C Up	1°C Up	1.5°C Up	2°C Up	2.5°C Up	3°C Up	3.5°C Up	4°C Up	
	5.6kΩ	1.5°C Down	1°C Down	0.5°C Down	No Change	0.5°C Up	1°C Up	1.5°C Up	2°C Up	2.5°C Up	3°C Up	3.5°C Up	
	8.2kΩ	2°C Down	1.5°C Down	1°C Down	0.5°C Down	No Change	0.5°C Up	1°C Up	1.5°C Up	2°C Up	2.5°C Up	3°C Up	
	10kΩ	2.5°C Down	2°C Down	1.5°C Down	1°C Down	0.5°C Down	No Change	0.5°C Up	1°C Up	1.5°C Up	2°C Up	2.5°C Up	
	12kΩ	3°C Down	2.5°C Down	2°C Down	1.5°C Down	1°C Down	0.5°C Down	No Change	0.5°C Up	1°C Up	1.5°C Up	2°C Up	
	18kΩ	3.5°C Down	3°C Down	2.5°C Down	2°C Down	1.5°C Down	1°C Down	0.5°C Down	No Change	0.5°C Up	1°C Up	1.5°C Up	
	33kΩ	4°C Down	3.5°C Down	3°C Down	2.5°C Down	2°C Down	1.5°C Down	1°C Down	0.5°C Down	No Change	0.5°C Up	1°C Up	
	56kΩ	4.5°C Down	4°C Down	3.5°C Down	3°C Down	2.5°C Down	2°C Down	1.5°C Down	1°C Down	0.5°C Down	No Change	0.5°C Up	
180kΩ	5°C Down	4.5°C Down	4°C Down	3.5°C Down	3°C Down	2.5°C Down	2°C Down	1.5°C Down	1°C Down	0.5°C Down	No Change		

NOTE: This circuit is designed to input the necessary temperature compensation values into the MICOM. This adjusts the refrigerator temperature, which is different in each model.

9-2-8 Key Button Input & Display Light-On Circuit

▶ The circuit shown above determines whether a function control key on the operation display is pushed. It also turns on the corresponding function indication LED DISPLAY. The drive type is the scan type.

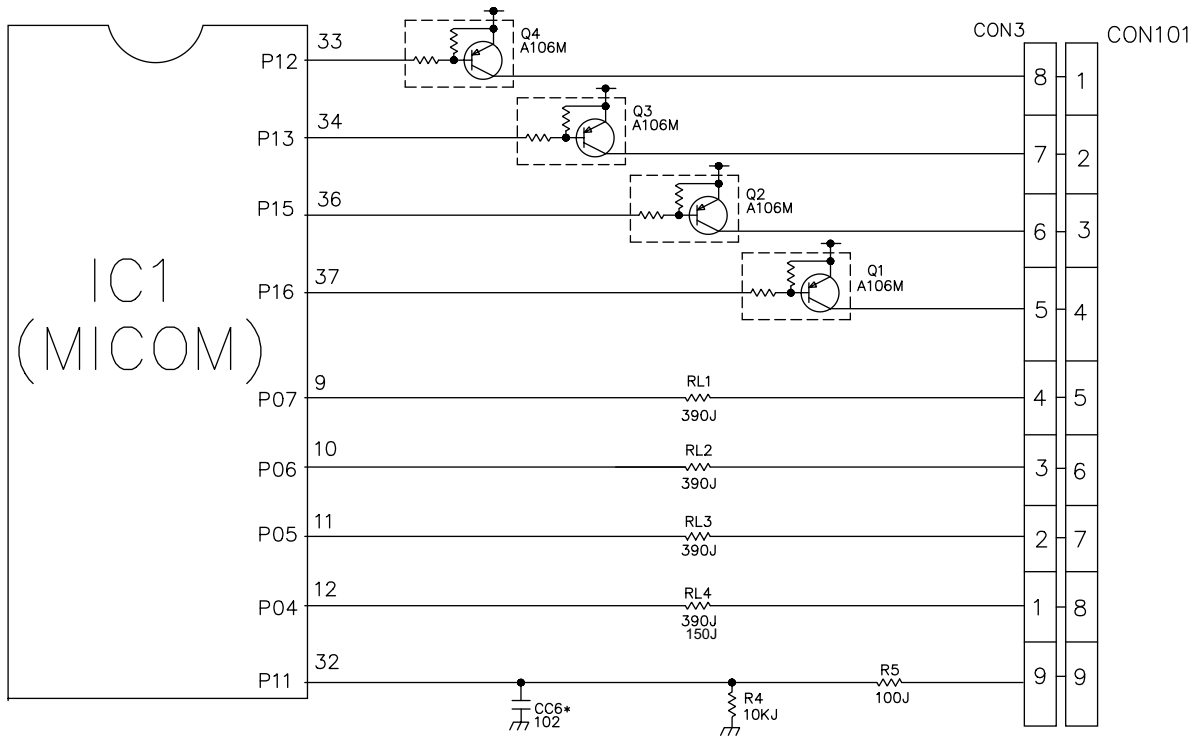

9-3 RESISTANCE SPECIFICATION OF SENSOR

TEMPERATURE DETECTED BY SENSOR	RESISTANCE OF FREEZER SENSOR	RESISTANCE OF REFRIGERATOR & DEFROST SENSOR & ROOM SENSOR
- 20 °C	22.3 KΩ	77 KΩ
- 15 °C	16.9 KΩ	60 KΩ
- 10 °C	13.0 KΩ	47.3 KΩ
- 5 °C	10.1 KΩ	38.4 KΩ
0 °C	7.8 KΩ	30 KΩ
+ 5 °C	6.2 KΩ	24.1 KΩ
+ 10 °C	4.9 KΩ	19.5 KΩ
+ 15 °C	3.9 KΩ	15.9 KΩ
+ 20 °C	3.1 KΩ	13 KΩ
+ 25 °C	2.5 KΩ	11 KΩ
+ 30 °C	2.0 KΩ	8.9 KΩ
+ 40 °C	1.4 KΩ	6.2 KΩ
+ 50 °C	0.8 KΩ	4.3 KΩ

- The resistance of the SENSOR has a $\pm 5\%$ common difference.
- Measure the resistance of the SENSOR after leaving it for over 3 minutes in the measuring temperature. This delay is necessary due to sensor response speed.

9-4 TROUBLESHOOTING

PROBLEM	INDICATED BY	CHECK	CHECKING METHOD	CAUSE	SOLUTION
POWER SOURCE is poor.	1. The whole DISPLAY LED/SEVEN SEGMENT DISPLAY is off. 2. DISPLAY LED/SEVEN SEGMENT DISPLAY operates abnormally	1. FREEZER/REFRIGERATOR.	Check if FREEZER/REFRIGERATOR DOOR IS OPEN and check display.	POWER SOURCE is poor.	Check outlet Voltage.
		2. If LAMP is dim. 3. The connection of the MAIN PWB CONNECTOR.	Check visually. Check connection of CONNECTOR.	Applied voltage error. CONNECTOR connection is poor. TRANS FUSE is open.	Use boosting TRANS. Reconnect CONNECTOR. Replace TRANS.
COOLING is poor.	NO COOLING.	1. If the COMPRESSOR operate.	USE TEST MODE 1 (forced COOLING). If less than 7 minutes pass after compressor shuts off, don't press the KEY and wait.	COMPRESSOR locked or blocked. OLP, PTC is poor. COMPRESSOR RELAY is poor.	Replace COMPRESSOR. Replace OLP, PTC. Replace MAIN PWB.
		2. If refrigerant is leaking.	Measure the amount of frost sticking on EVAPORATOR and the surface temperature of the condenser pipe.	Refrigerant leakage.	Check the connection of the black wire of the MAIN PWB CONNECTOR (CON2). Replace the leaking part and replace any lost refrigerant.
FREEZER TEMPERATURE is incorrect	1. If FAN MOTOR operates. USE TEST MODE 1 (forced COOLING).	1. If FAN MOTOR operates.	FAN MOTOR is poor.	FAN MOTOR is poor.	Replace the FAN MOTOR.
		2. If DEFROSTING is normal.	Check the amount of frost sticking on the EVAPORATOR.	DEFROSTING is poor.	Certify the MOTOR and the connection of the black wire of the MAIN PWB CONNECTOR (CON2). See DEFROSTING is poor.
		3. If SENSOR is normal.	Check the resistance of the Refrigerator SENSOR.	SENSOR RESISTANCE is poor.	Replace SENSOR.
		4. Door Line contact.	Check the seal when the door is closed.	Door liner damaged.	Replace door liner.

PROBLEM	INDICATED BY	CHECK	CHECKING METHOD	CAUSE	SOLUTION
COOLING is poor.	If REFRIGERATOR TEMPERATURE is too low.	1. If FREEZER TEMPERATURE is normal.	Check is FREEZER TEMPERATURE is too low.		Make sure the DOOR is attached. Replace FAN MOTOR.
		2. If amount of cool air from FAN MOTOR is sufficient.	Make sure that the amount and speed of cool air are sufficient by touching the check supplied on the REFRIGERATOR.	FAN MOTOR is poor. Passage of cool air is blocked. EVA frozen.	Remove impurities. See DEFROSTING is poor.
		3. Door Line contact.	Check door seal when door is closed.	Door liner damaged.	Replace Door liner.
DEFROSTING is poor.	NO DEFROSTING.	1. If HEATER emits heat.	USE TEST MODE2 (forced DEFROSTING).	HEATER disconnection.	Replace HEATER.
				TEMPERATURE FUSE disconnection.	Replace TEMPERATURE FUSE.
				Connection is poor.	Check EVAPORATOR connection and wire of MAIN PWB CONNECTOR.
				DEFROST-SENSOR is poor.	Replace DEFROST-SENSOR.
				HEATER RELAY is poor.	Replace RY3 of MAIN PWB.
				DRAIN PIPE is blocked.	Remove ice and impurities. Check HEATER PLATE resistance.
				Connection is poor.	Reassemble the DEFROST-SENSOR.
				DOOR does not close properly.	Reassemble DOOR. Replace GASKET.
				Make sure that DEFROST SENSOR is connected.	
				Make sure that FREEZER/ REFRIGERATOR DOOR is closed.	

9-5 MAIN PWB ASSEMBLY AND PARTS LIST

9-5-1 Main PWB Assembly

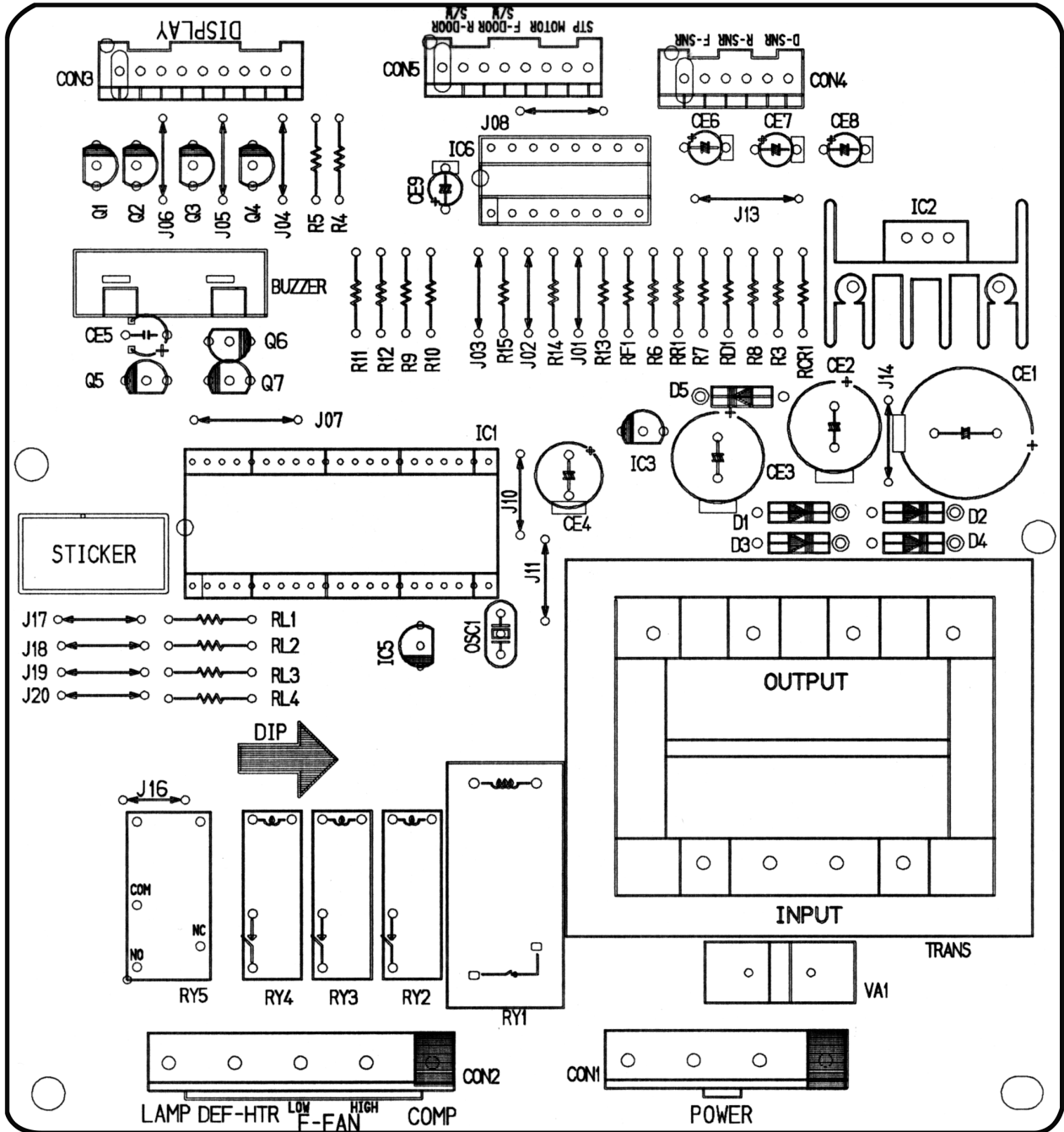

9-5-2 Replacement Parts List

No	P/NO	DESCRIPTION	SPEC	MAKER	REMARK
1	6670_BB889A = C	PWB(PCB)	KS-PJT GOOD MDL	DOO SAN	T-1,6
2	-	-	-	-	-
3	6170_JB2002H	TRANSFORMER,LOW VOLTAGE	240V 15V YES GR-MICOM ONE TAB	TAE SUNG	TRANS
4	6170_JB2002M	TRANSFORMER,LOW VOLTAGE	260V 15V YES GR-MICOM ONE TAB	TAE SUNG	TRANS
5	6170_JB2002R	TRANSFORMER,LOW VOLTAGE	140V 15V YES GR-MICOM ONE TAB	TAE SUNG	TRANS
6	6170_JB2002W	TRANSFORMER,LOW VOLTAGE	115V 15V YES GR-MICOM ONE TAB	TAE SUNG	TRANS
7	-	-	-	-	-
8	6630A09106C	CONNECTOR (ICIRC),WAFER	YH396-07AV YEONHO 7PIN 3.96MM STRAIGHT SN	YEON HO	CON1
9	6630A09106D	CONNECTOR (ICIRC),WAFER	YH396-09AV	YEON HO	CON2
10	6630A09106B	CONNECTOR (ICIRC),WAFER	YH396-05AV	YEON HO	-
11	6630_BB8007G	CONNECTOR (ICIRC),WAFER	917786-1 AMP 8PIN 2.5MM STRAIGHT SN	AMP	CON5
12	6630_BB8007H	CONNECTOR (ICIRC),WAFER	917787-1 AMP 9PIN 2.5MM STRAIGHT SN	AMP	CON3
13	6630_BB8007E	CONNECTOR (ICIRC),WAFER	917784-1 AMP 6PIN 2.5MM STRAIGHT SN	AMP	CON4
14	-	-	-	-	-
15	01ZZ_JB2023L	IC,DRAWING	TM97C84GN 42 SDIP BK KS-BETTER/GOOD(MASK)	TOSHIBA	IC1(01ZZ_JB2022M)
16	01ZZ_JB2022	IC,DRAWING	-	TOSHIBA	IC1(01ZZ_JB2022)
17	01ZZ_JB2022	IC,DRAWING	-	TOSHIBA	IC1(01ZZ_JB2022)
18	-	-	-	-	-
19	OIKE781200B	IC,KEC	K1A7812P1 12V IA,KEC - - - -	KEC	IC2
20	OIKE781200M	IC,KEC	K1A7812P1 30IP BK 12V IA REFORM	KEC	-
21	OIKE780500A	IC,KEC	K1A7805P,3PIN,DIP - KEC	KEC	IC3
22	O1STLM001A	IC,STANDARD LOGIC	M54563P MITSUBISHI 20 R/TP CONVERT	MITSUBISHI	-
23	O1T0777400A	IC,TOSHIBA	TA7774AP 16 SDIP BK STEPPING MOTOR	TOSHIBA	IC6
24	OIKE650030C	IC,KEC	K1D65003AF 16SOP BK 7CH DRIVER	KEC	IC4
25	OIKE704200A	IC,KEC	K1A7042P 3P BK RESET	KEC	IC5
26	O1FH934600D	IC,ROHM	BR93LC46FF-W 8PIN SOP BK EEPROM -	ROHM	-
27	-	-	-	-	-
28	6920000001A	RELAY	ALE15B12 MATSUSHITA 250VAC 16A 12VDC IA NO VENTING	NAIS	RY1
29	6920W0010A	RELAY	US11-125 YUYU 250VAC 3A 12VDC IA	YUYU	-
30	6920_JB2003B	RELAY	ALD112 MATSUSHITA 250VAC 3A 12VDC IA	OMRON	RY2-RY4
31	6920_JB2009A = B	RELAY	696B-14 250VAC 5A 12VDC IC	OMRON	RY5
32	-	-	-	-	-
33	-	-	-	-	-
34	6212_JB8001B	RESONATOR,CERAMIC	CST90400 MURATA 4MHZ +/- 0.5% 15PF TP NONE	MURATA	OSC1(J570-00012B)
35	6102W5V006A	VARIABLE	INR14D331 ILJIN UL/CSA/VDE BK	ILJIN	VA1
36	6102_JB8003A	VARIABLE	INR14D271 ILJIN UL/VDE TP 270V	ILJIN	VA1
37	6102_JB8001B	VARIABLE	INR14D621 ILJIN UL/VDE BK 620V	ILJIN	VA1
38	0DD400709AA	DIODE,RECTIFIERS	IN4007 TP MOTOROLA - - IA - - -	DELTA	DI-05
39	-	-	-	-	-
40	-	-	-	-	-
41	OCE2285J610	CAPACITOR,AL.,ELECTROLYTIC	2200 UF 5MS,SG 35V M FL BULK	SAM HWA	CE1
42	OCE1086J610	CAPACITOR,FIXED ELECTROLYTIC	1000UF 5MS,SG 35V 20% FL BULK	SAM HWA	-
43	OCE1086H618	CAPACITOR,AL.,ELECTROLYTIC	1000 UF 5MS,SG 25V M FL TP 5	SAM HWA	CE2
44	OCE4776H618	CAPACITOR,FIXED ELECTROLYTIC	470UF 5MS,SG 25V 20% FL TP 5	SAM HWA	CE3
45	OCE2276F638	CAPACITOR,FIXED ELECTROLYTIC	220UF 5MS,SG 16V 20% FM5 TP 5	SAM HWA	CE4
46	OCE1076H638	CAPACITOR,FIXED ELECTROLYTIC	100UF 5MS,SG 25V 20% FM5 TP 5	SAM HWA	-
47	OCE1066K638	CAPACITOR,FIXED ELECTROLYTIC	100UF 5MS,SG 50V 20% FM5 TP 5	SAM HWA	CE6-CE8
48	OCE1056K638	CAPACITOR,FIXED ELECTROLYTIC	10UF 5MS,SG 50V 20% FM5 TP 5	SAM HWA	CE9
49	OCE476H638	CAPACITOR,FIXED ELECTROLYTIC	47UF 5MS,SG 25V 20% FM5 TP 5	SAM HWA	CE5
50	0C02231N409	CAPACITOR,POLYESTER	0,022 UF D 100V J PE TP	SAM HWA	-
51	0CK1020K96A	CAPACITOR,FIXED CERAMIC(HIGH DIELECTRIC)	10NF 2012 50V 80%, -20% R/TP X7R	-	CC6
52	0CK2230K96A	CAPACITOR,FIXED CERAMIC(HIGH DIELECTRIC)	22NF 2012 50V 80%, -20% R/TP X7R	MURATA	CC7-CC11
53	-	-	-	-	-
54	0CK1040K94A	CAPACITOR,FIXED CERAMIC(HIGH DIELECTRIC)	100NF 2012 50V R/TP (GRM40X7R104K50PE1)	MURATA	CC1-CC5
55	-	-	-	-	-
56	0CK1040K949	CAPACITOR,FIXED CERAMIC(HIGH DIELECTRIC)	0,1UF D 50V 80%, -20% F1Y5V1 TA52	-	-
57	-	-	-	MURATA	-
58	-	-	-	-	-
59	0RD15006609	RESISTOR,FIXED CARBON FILM	150 OHM 1/4W 5.00% TA52	SMART	RL4
60	0RD39006609	RESISTOR,FIXED CARBON FILM	390 OHM 1/4 W 5.00% TA52	SMART	RL1-RL3
61	0RD10006609	RESISTOR,FIXED CARBON FILM	100 OHM 1/4 W 5.00% TA52	SMART	R5
62	0RJ1001E672	RESISTOR,METAL GLAZED(CHIP)	1K OHM 1/8 W 5% 2012 R/TP	ROHM	R16
63	0RJ2001E672	RESISTOR,METAL GLAZED(CHIP)	2K OHM 1/8 W 5% 2012 R/TP	ROHM	-
64	0RD20016609	RESISTOR,FIXED CARBON FILM	2K OHM 1/4 W 5.00% TA52	SMART	R6-R12
65	0RH2200L622	RESISTOR,METAL GLAZED(CHIP)	220 OHM 1/8 W 5% 2012 5.00% D	ROHM	R17
66	0RJ2201E672	RESISTOR,METAL GLAZED(CHIP)	2.2K OHM 1/8 W 5% 2012 R/TP	ROHM	R7
67	0RJ4701E672	RESISTOR,METAL GLAZED(CHIP)	4.7K OHM 1/8 W 5% 2012 R/TP	ROHM	R1
68	0RJ4701E672	RESISTOR,METAL GLAZED(CHIP)	4.7K OHM 1/8 W 5% 2012 R/TP	ROHM	-
69	0RD47016609	RESISTOR,FIXED CARBON FILM	4.7K OHM 1/4 W 5.00% TA52	SMART	-
70	0RJ1002E672	RESISTOR,METAL GLAZED(CHIP)	10K OHM 1/8 W 5% 2012 R/TP	ROHM	-
71	0RJ1002E672	RESISTOR,METAL GLAZED(CHIP)	10K OHM 1/8 W 5% 2012 R/TP	ROHM	-
72	0RD10026609	RESISTOR,FIXED CARBON FILM	10K OHM 1/4 W 5.00% TA52	SMART	R3,R4,RCR1,R13-R15
73	0RJ2702E672	RESISTOR,METAL GLAZED(CHIP)	27K OHM 1/8 W 5% 2012 R/TP	ROHM	-
74	0RJ1004E672	RESISTOR,METAL GLAZED(CHIP)	1M OHM 1/8 W 5% 2012 R/TP	ROHM	R2
75	0RJ2612E472	RESISTOR,FIXED METAL FILM	26.1K OHM 1/4 W 1.00% TA52	SMART	RR1, RD1
76	0RJ1622E472	RESISTOR,FIXED METAL FILM	16.2K OHM 1/4 W 1.00% TA52	SMART	RF1
77	-	-	-	-	-
78	-	-	-	-	-
79	3J03565D	FUSE,DRAWING	9A 250V - -	SAM JU	-
80	OTR106009AC	TRANSISTOR	KRA106MIKRA22061 TP KEC	KEC	Q1-Q4
81	OTR106009AF	TRANSISTOR	KRC 106M KEC	KEC	Q5,Q7
82	OTR319009AA	TRANSISTOR	KTC319B-TP-Y (KTC1815)KEC	KEC	-
83	6908_B3002F	BUZZER	CBE2220BP DAE YOUNG P1E20 2KHZ 750B1CH1NA1	DAE YOUNG	BUZZER
84	6600RRT001Z	SWITCH,TACT	JTP1280AG JEIL 12V DC 50MA	JEIL	-
85	6854B50001A	JUMP WIRE	0,6MM 52MM TP TAPING SN(6MM)	-	J16
86	6854B50001A	JUMP WIRE	0,6MM 52MM TP TAPING SN(10MM)	-	J1-J6,J8,J10,J14,J17-J20
87	6854B50001A	JUMP WIRE	0,6MM 52MM TP TAPING SN(12,5MM)	-	J13
88	6854B50001A	JUMP WIRE	0,6MM 52MM TP TAPING SN(12,5MM)	-	J07
89	6854B50001A	JUMP WIRE	0,6MM 52MM TP TAPING SN	-	-
90	6854B50001A	JUMP WIRE	0,6MM 52MM TP TAPING SN	-	-
91	4920_B3003A	HEAT SINK	30*25*30 IC-12V R-B50,51,52,53,54,55,56 2PIN 1-SCREW 3	-	HC2
92	15BF030241B	SCREW TAP TITE(S),BINDING HEAD	+ D3.0 LB.0 M5WR3/FZY	-	HC2
93	9WVF0120000	SOLDER(ROSN WIRE) R50	DI.20	HEE SUNG	-
94	49111004	SOLDER,SOLDERING	H63A	-	-
95	59333105	FLUX	SG;0.825-0.830 KOREA F.H-206	KOKI	-

9-5-3 PWB Assembly, Display, And Parts List

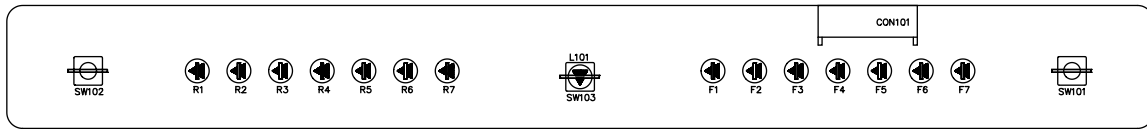

Qty	No	P/NO	DESCRIPTION	SPEC	MAKER	REMARK
1	1	6870JB8091A	PWB(PCB)	KS-PJT GOOD/BETTER DISPLAY	DOO SAN	t=1.6
	2					
1	3	6630AQ9159H	WAFER	SMAW250-09	YEON HO	CON101
	4					
2	5	6600RRT002K 6600JB8005A	SWITCH,TACT	JTP1230A JEIL 12V DC 50MA KPT-1105A	JEIL KYUNG IN	SW101,102
1	6	-	TACT S/W	KPT-1109G	KYUNG IN	SW103
14	7	0DLLE0019AA	LED	LT1824-81-BCM TP GREEN 2		R1~R7,F1~F7
3	8	0DD414809AA	DIODE,SWITCHING	1N4148 26MM	PYUNG CHANG DELTA	D101,102,103
12	10	6854B50001A	JUMP WIRE	0.6MM 52MM TP TAPING SN <10MM	-	J101~J112
	11					
-	12	9VWF0120000	SOLDER(ROSN WIRE) RSO	D1.20	HEE SUNG	-
0.001	13	49111004	SOLDER,SOLDERING	H63A	-	-
0.0005	14	59333105	FLUX	SG;0.825-0.830 KOREA F.H-206	KOKI	-

9-6 PWB DIAGRAM

9-6-1 PWB Main Assembly

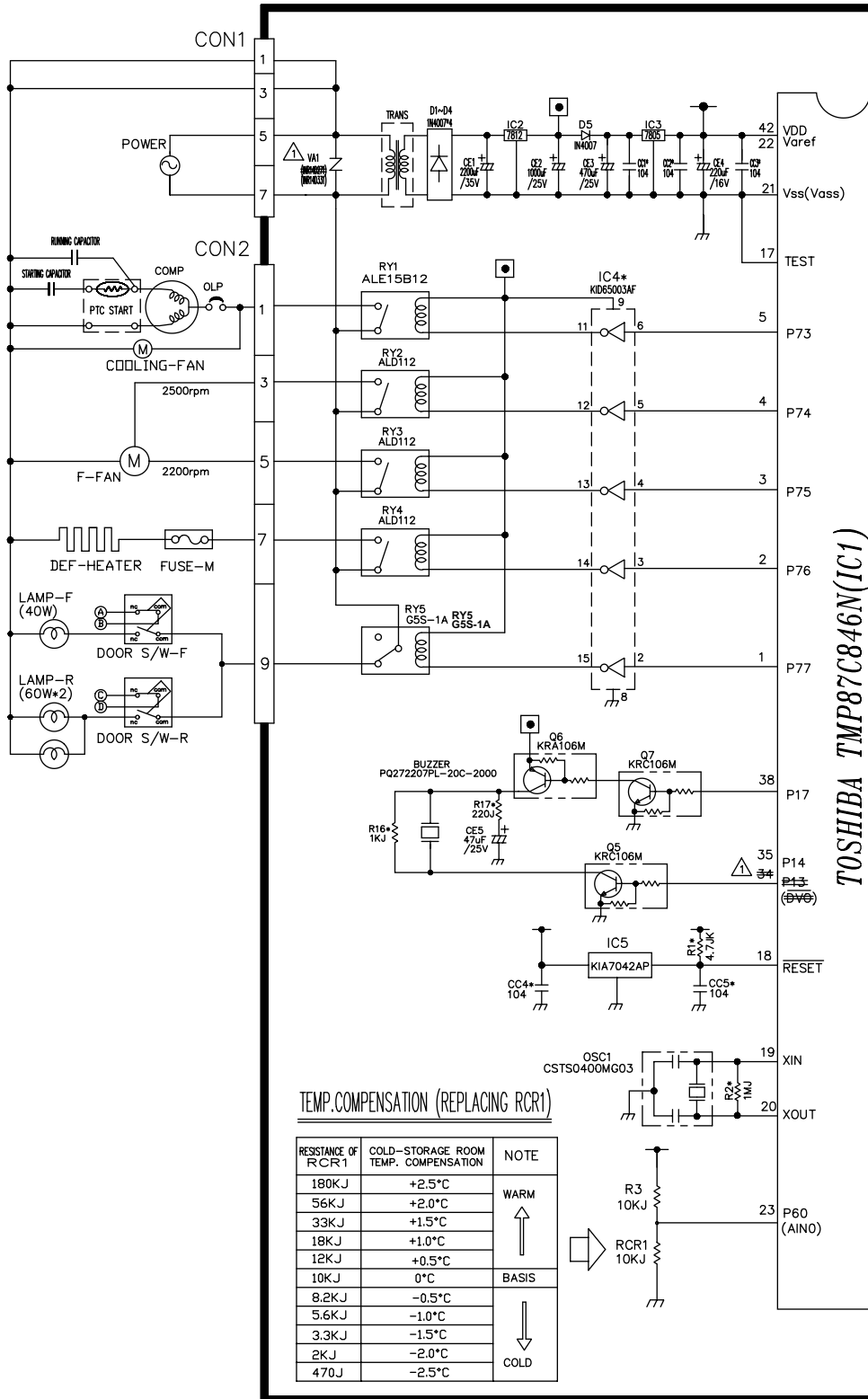
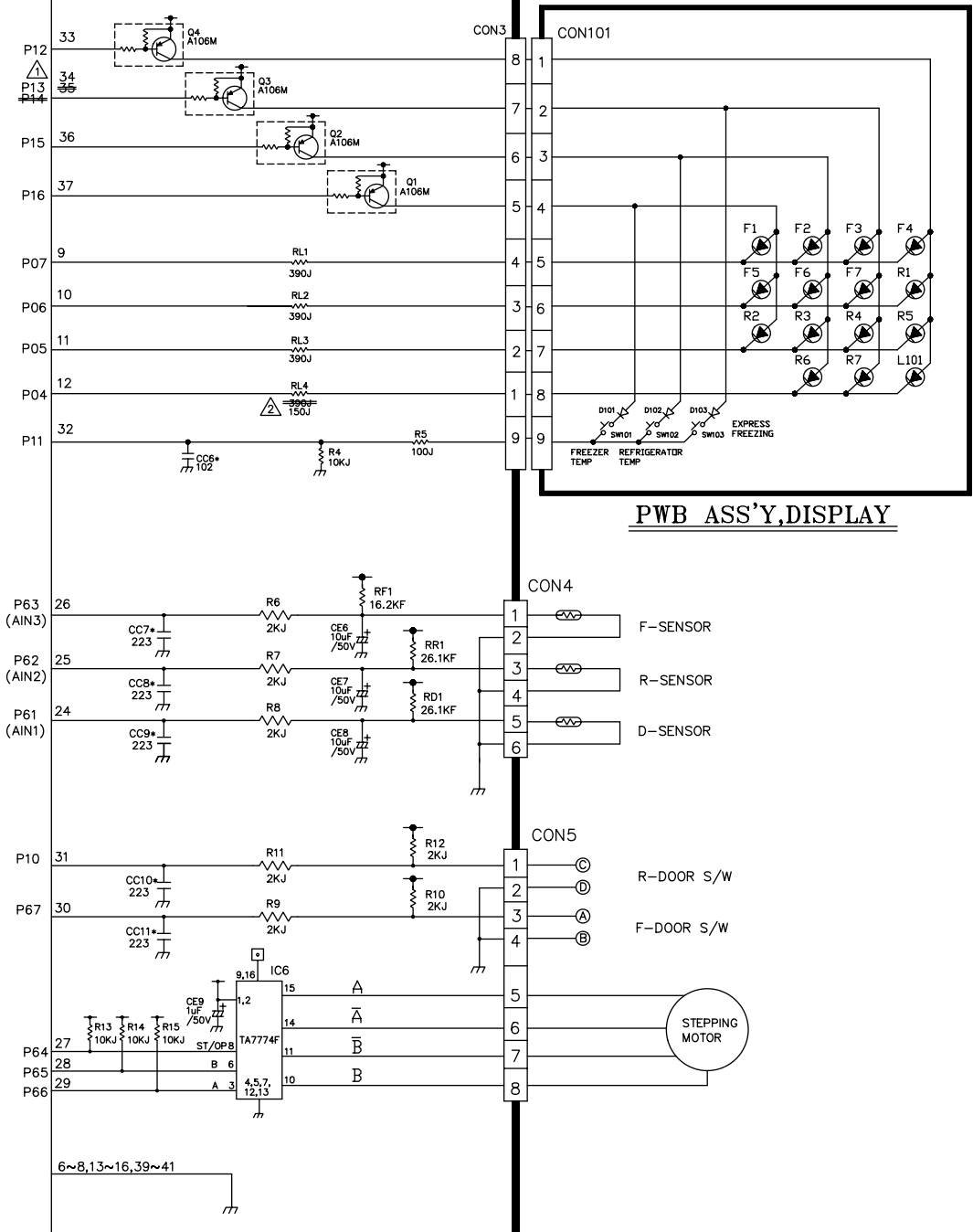

FIG.1 CIRCUIT DIAGRAM



PWB ASS'Y, DISPLAY

EXPLODED VIEW

CASE PARTS

CAUTION: Use the part number to order part, not the position number.

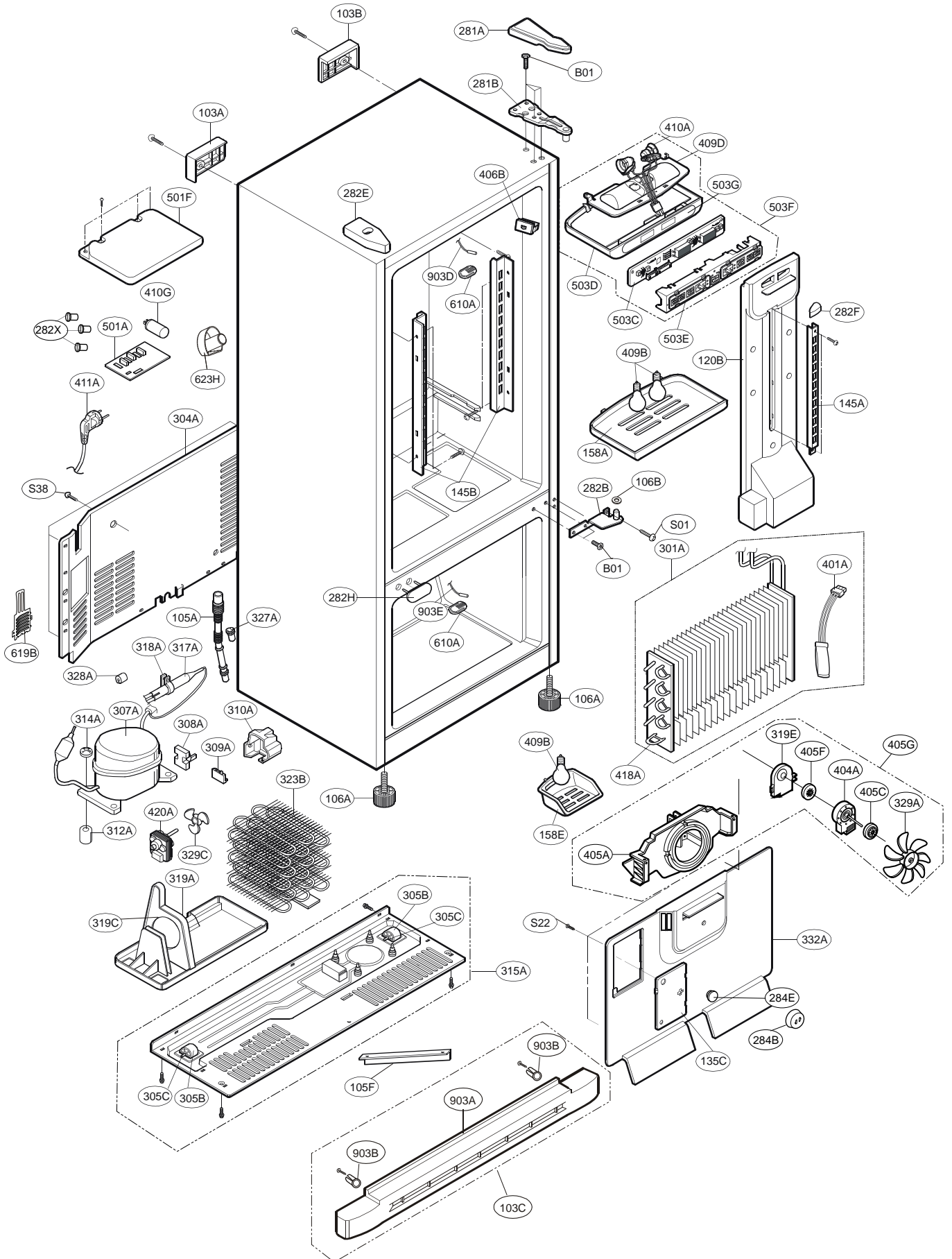

FREEZER PARTS

CAUTION: Use the part number to order part, not the position number.

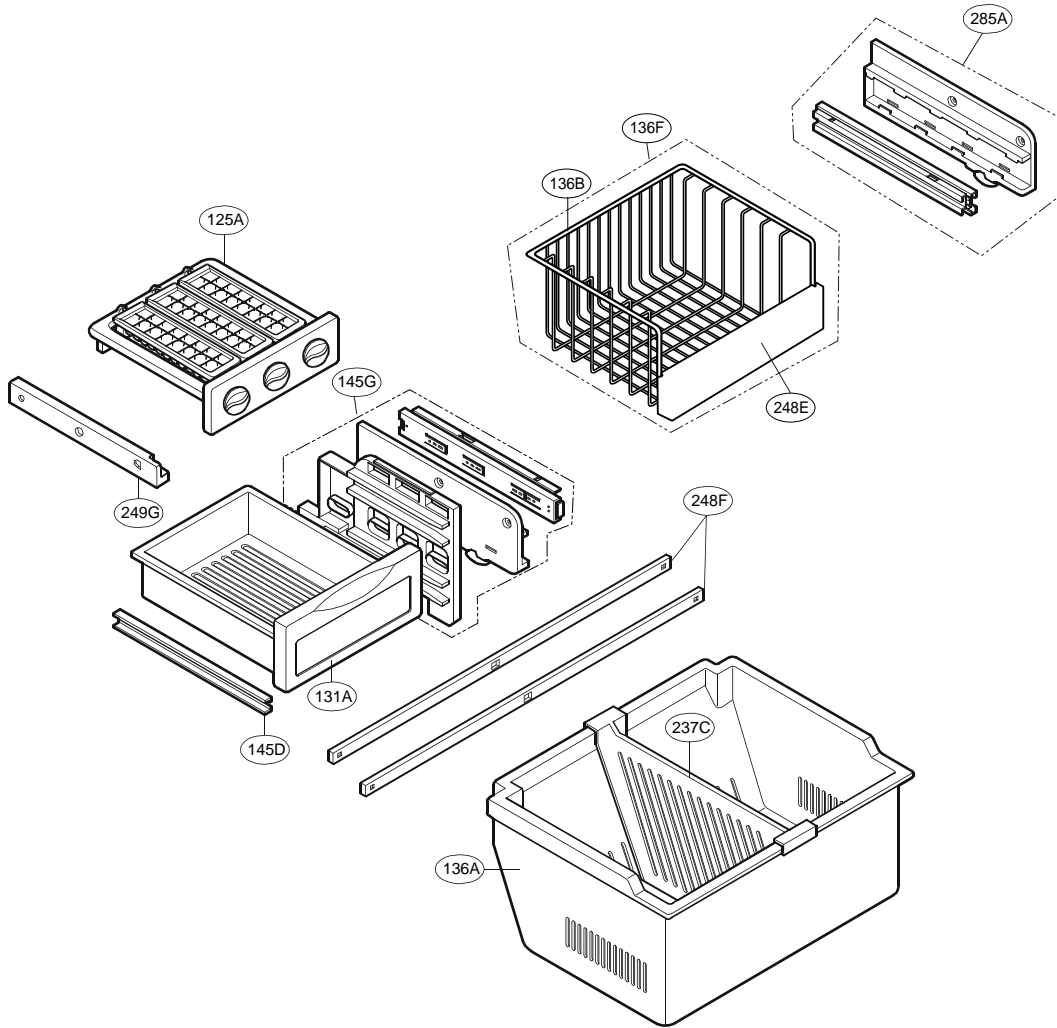

REFRIGERATOR PARTS

CAUTION: Use the part number to order part, not the position number.

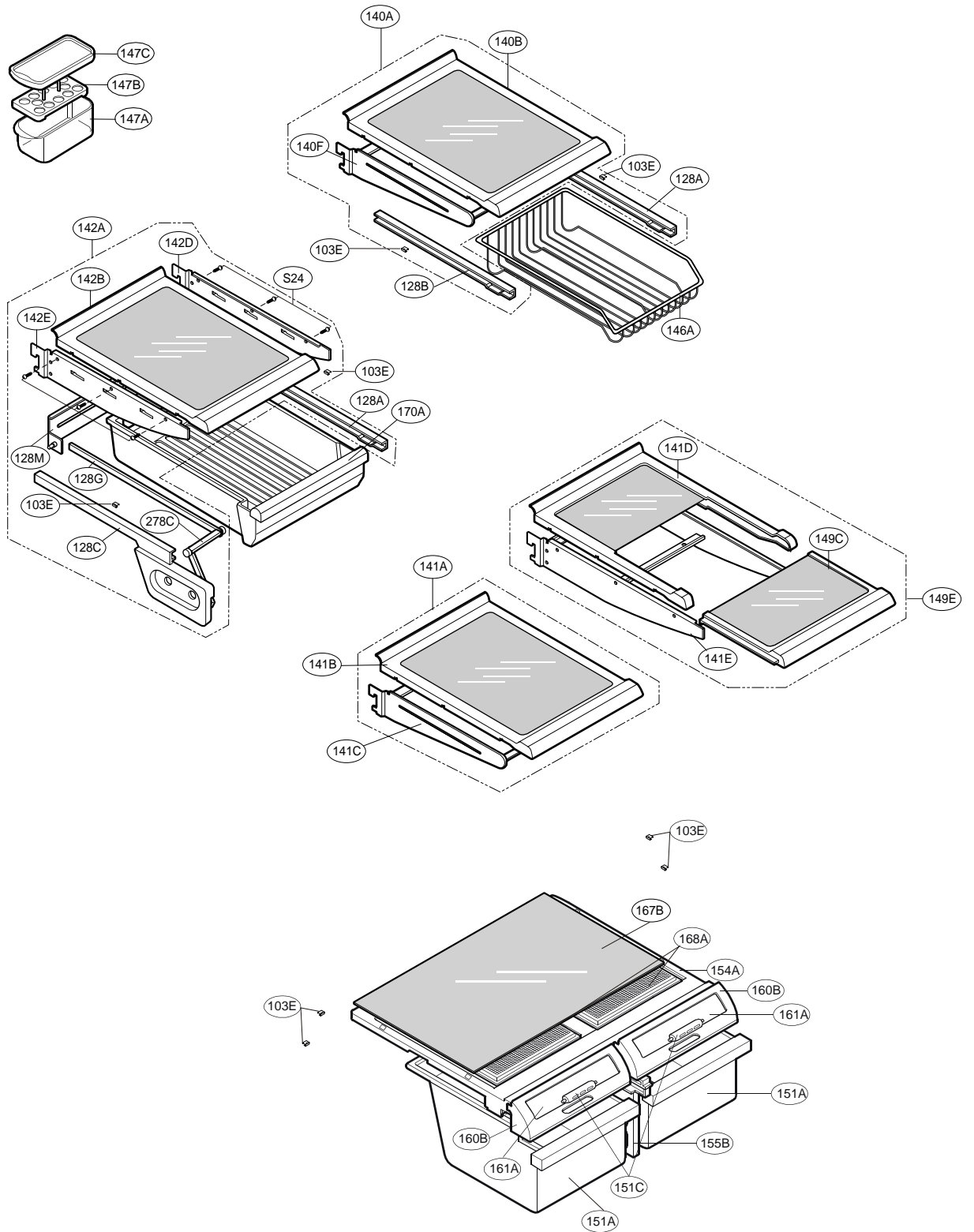

DOOR PARTS

CAUTION: Use the part number to order part, not the position number.

Models:
LRDN22734WW

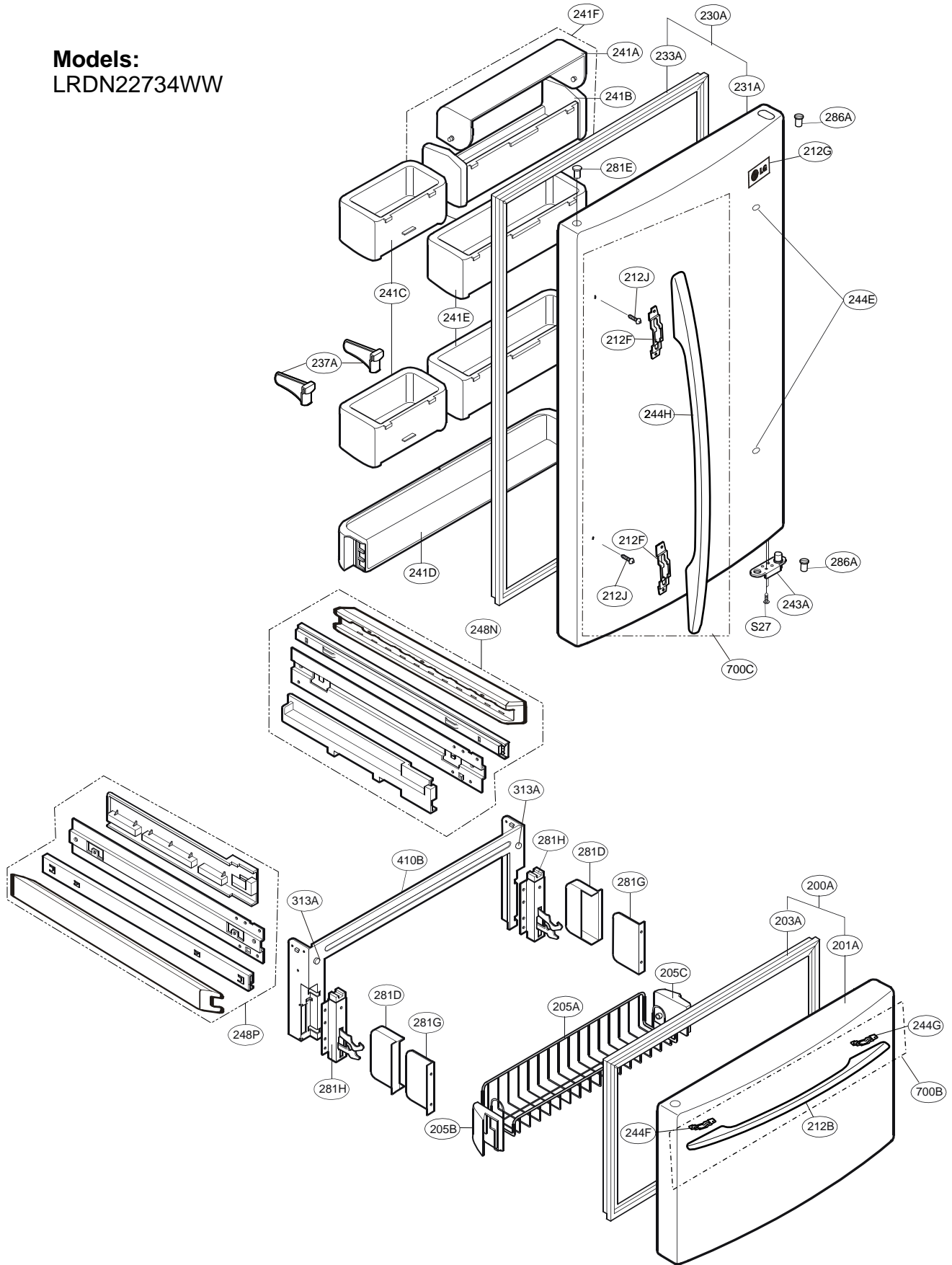

DOOR PARTS

CAUTION: Use the part number to order part, not the position number.

Models:

LRDN22734SB

LRDN22734ST

LRDN22734TT

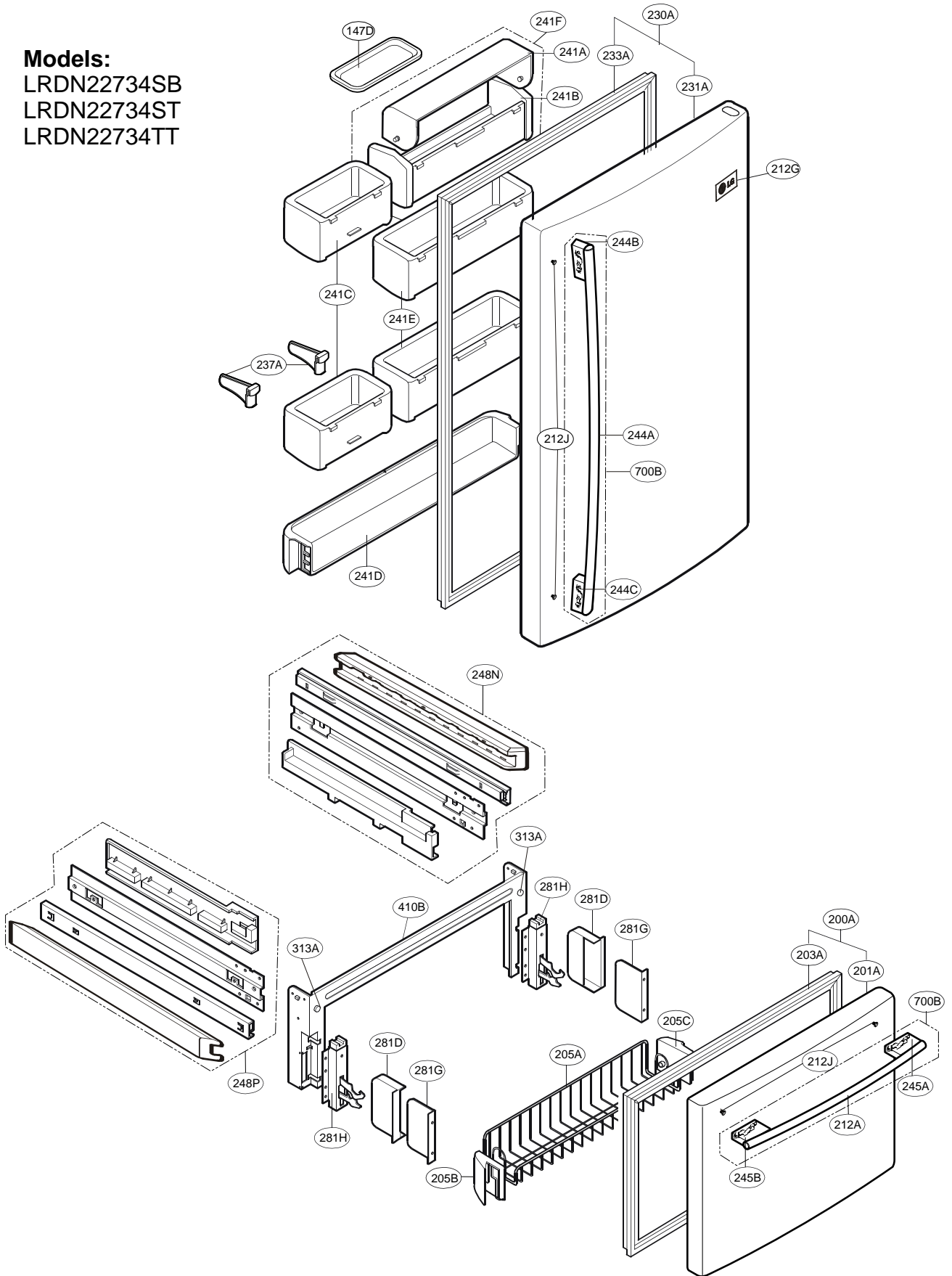



June, 2009