

This Owner's Manual is provided and hosted by [Appliance Factory Parts](http://www.appliancefactoryparts.com).



CUISINART DCC-2600 Owner's Manual

[Shop genuine replacement parts for CUISINART
DCC-2600](#)



[Find Your CUISINART Small Appliance Parts - Select From 213 Models](#)

----- Manual continues below -----

Cuisinart®

INSTRUCTION BOOKLET



Brew Central® 14-Cup Programmable Coffeemaker

DCC-2600 Series

For your safety and continued enjoyment of this product, always read the instruction book carefully before using.

IMPORTANT SAFEGUARDS

When using electrical appliances, basic safety precautions should always be followed to reduce the risk of fire, electric shock and/or injury to persons, including the following:

- 1. READ ALL INSTRUCTIONS.**
2. Do not touch hot surfaces. Use handles and knobs.
3. To protect against electric shock, do not place cord, plug, or base unit in water or other liquids.
4. This appliance should not be used by or near children or individuals with certain disabilities.
5. Always unplug from outlet when not in use and before cleaning. Allow to cool before putting on or taking off parts and before cleaning the appliance.
6. Do not operate any appliance with a damaged cord or plug or after the appliance malfunctions or has been dropped or damaged in any manner. Return appliance to the nearest Cuisinart Repair Center for examination, repair, and electrical or mechanical adjustment.
7. The use of accessory attachments not recommended by Cuisinart may cause injuries.
8. Do not use outdoors.
9. Do not let cord hang over edge of table or counter, or touch hot surface.
10. Do not place on or near a hot gas or electric burner, or in a heated oven.
11. Always fill water reservoir first, then plug cord into the wall outlet. To disconnect, push the Off button, then remove plug from wall outlet.
12. Do not use appliance for other than intended use.
13. Snap lid securely onto carafe before serving any beverages.
14. Scalding may occur if the lid is removed during the brewing cycle.
15. The glass carafe is designed for use with these appliances only. It must never be used on the range top.
16. Do not set a hot carafe on a wet or cold surface.
17. Do not use a cracked carafe or a carafe having a loose or weakened handle.
18. Do not clean carafe or heating plate with cleansers, steel wool pads, or other abrasive materials.
19. **WARNING: TO REDUCE THE RISK OF FIRE OR ELECTRIC SHOCK, DO NOT REMOVE THE BASE PANEL. NO USER SERVICEABLE PARTS ARE INSIDE. REPAIR SHOULD BE DONE ONLY BY AUTHORIZED PERSONNEL.**
20. Avoid contact with moving parts.
21. Do not place cloth or otherwise restrict airflow beneath coffeemaker.
22. Use only the Cuisinart® Gold Tone Commercial Style Filter or standard basket paper filter with this unit. **OTHER GOLD TONE PERMANENT FILTERS MAY CAUSE THE COFFEEMAKER TO OVERFLOW.**

SAVE THESE INSTRUCTIONS

FOR HOUSEHOLD USE ONLY

WARNING: RISK OF FIRE OR ELECTRIC SHOCK



The lightning flash with arrowhead symbol within an equilateral triangle is intended to alert the user to the presence of uninsulated dangerous voltage within the product's enclosure that may be of sufficient magnitude to constitute a risk of fire or electric shock to persons.



The exclamation point within an equilateral triangle is intended to alert the user to the presence of important operating and maintenance (servicing) instructions in the literature accompanying the appliance.

SPECIAL CORD SET INSTRUCTIONS

A short power-supply cord is provided to reduce the risks resulting from becoming entangled in or tripping over a longer cord.

Longer extension cords are available and may be used if care is exercised in their use.

If a long extension cord is used, the marked electrical rating of the extension cord must be at least as great as the electrical rating of the appliance, and the longer cord should be arranged so that it will not drape over the countertop or tabletop where it can be pulled on by children or tripped over.

NOTICE

This appliance has a polarized plug (one blade is wider than the other). To reduce the risk of electric shock, this plug will fit into a polarized outlet only one way. If the plug does not fit fully into the outlet, reverse the plug. If it still does not fit, contact a qualified electrician. Do not modify the plug in any way.

OPERATING NOTICE

Clogging and backing up of water and/or coffee in the filter basket can occur under any or a combination of any of the following conditions: The use of too finely ground coffee, using two or more paper filters, using the gold tone filter in conjunction with a paper filter or not properly cleaning coffee grounds from the gold tone filter, or allowing coffee grounds to spill over the filter.

Caution: Never open the filter basket during the brewing cycle, even if no water is draining from the filter basket, since extremely hot water/coffee can spill out from the filter basket and cause injury. If water/coffee is not draining from the filter basket during the brewing cycle, unplug the unit and wait 10 minutes before opening and checking the filter basket.



CONTENTS

Important Safeguards	2
Important Unpacking Instructions	4
The Quest for the Perfect Cup of Coffee	4
Features and Benefits	5
Control Panel	6
Programming Your Coffeemaker	7
Before Brewing your First Pot	7
Charcoal Water Filter	8
Brew Pause Feature	8
Cleaning and Maintenance	9
Warranty	10

IMPORTANT UNPACKING INSTRUCTIONS

1. Place the box on a large, sturdy, flat surface.
2. Remove the instruction book and any other literature.
3. Turn the box so that the back side of the coffeemaker is down and slide the coffeemaker from the box.
4. After the coffeemaker has been removed, place the box out of the way and lift off the left and right polyfoam insert.
5. Grasp the carafe by its handle, remove it from the heating plate, and remove the polybag.
6. Remove the polybag covering the coffeemaker.

Save all packing materials in case you have to ship the machine in the future.

KEEP ALL PLASTIC BAGS AWAY FROM CHILDREN.

THE QUEST FOR THE PERFECT CUP OF COFFEE

Element 1: Water

Coffee is 98% water. The quality of that water is as important as the quality of your coffee. If water doesn't taste good from the tap, it won't taste good in your coffee. Cuisinart includes a charcoal water filter to remove chlorine, bad tastes and odors, for the purest coffee flavor, every time you brew.

Element 2: Coffee

While coffee is 98% water, all of the flavor comes from the beans. To achieve the same great taste you enjoy at a coffee bar, you need to use the same quality of coffee. If you choose to grind your own beans, buy them fresh and whole. Buy only about a two-week supply at a time, because once the bean is broken, its flavor degrades quickly.

Element 3: Grind

The grind is critical for proper flavor extraction. If the grind is too fine, over-extraction and bitterness will result. Too fine a grind may also clog the filter. If grind is too coarse, the water will pass through too quickly and the maximum flavor will not be extracted. When grinding your own beans, we recommend a medium-fine grind.

Element 4: Proportion

Coffee that is too strong or too weak is always a disappointment. Follow the recommended portions of ground coffee in the instructions under MAKING COFFEE below, and later adjust the amount to suit your taste.

FEATURES AND BENEFITS

1. Reservoir Cover

Flips back for easy filling.

2. Water Reservoir with Water Level Indicator Window

3. Showerhead

Distributes water evenly over coffee, reducing temperature loss as water passes through grounds.

4. Charcoal Water Filter

Charcoal water filter eliminates chlorine, calcium and bad tastes and odors from tap water.

5. Filter Basket

Holds a #4 paper filter or a permanent filter.

6. Filter Basket Holder

7. Control Panel

See detailed illustration, page 6.

8. Brew Pause

Stops flow of coffee from basket when carafe is removed from the heater plate, so a cup can be poured in mid-brew.

9. Carafe

The easy-pour, no-drip 14-cup carafe has an ergonomic handle and brewed coffee markings for two to fourteen cups.

10. Adjustable Heater Plate

Allows you to keep brewed coffee at desired temperature. Scratch-resistant with black, nonstick coating.

11. Ready Tone

Signals the end of the brew cycle with five beeps.

12. Cord Storage

13. Power Loss Back-up System

One-minute protection in case a breaker trips, the unit is unplugged, or the power fails. It holds all programmed information, including time of day, auto on time and auto off time.

14. Measuring Scoop

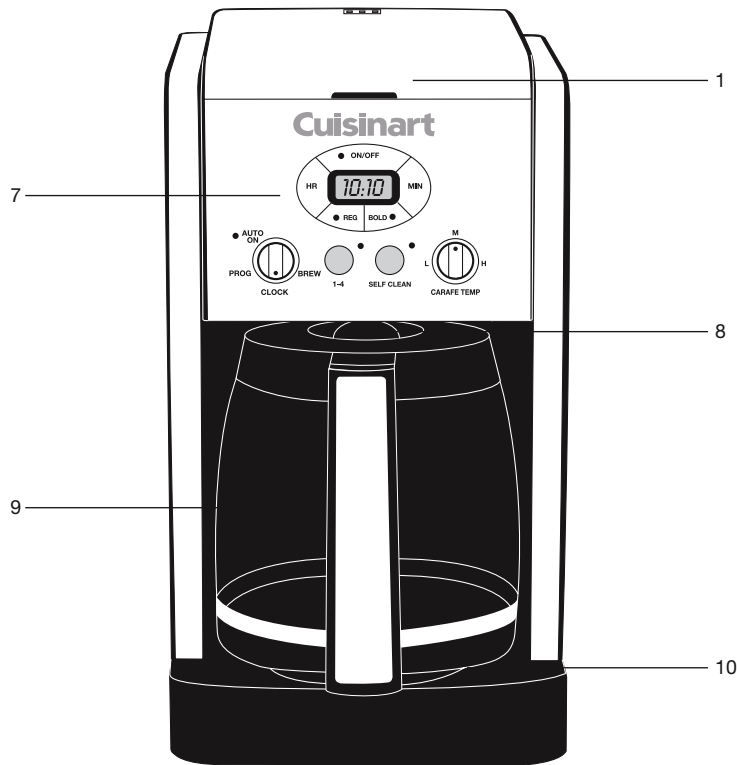

GETTING TO KNOW YOUR CONTROL PANEL

Detailed programming and use instructions are on pages 7 and 8.

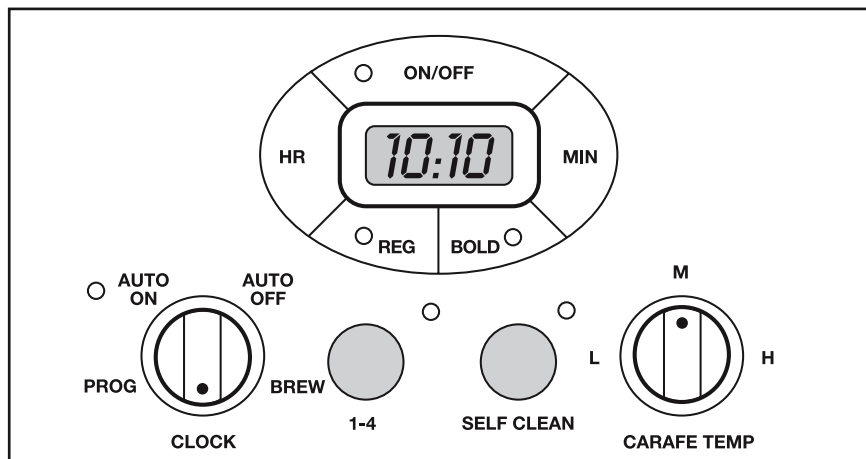

1. On/Off Button

Use to turn your coffeemaker on and off.
Works in tandem with the function knob.

2. Clock Display

Displays time of day, Auto On, and Auto Off times.

3. Hour and Minute Buttons

Use to set hours and minutes for time of day, Auto On, and Auto Off time.

4. Strength Selector

Regular and Bold buttons let you choose the intensity of coffee flavor you prefer.

5. 1-4 Cup Setting

Improves extraction, flavor and temperature when brewing fewer than 5 cups.

6. Self-Clean Setting

Indicates time to clean coffeemaker to remove calcium buildup.

7. Carafe Temperature Knob

Set the heater plate to Low(L), Medium(M), or High(H) to keep coffee in the carafe at the temperature you prefer.

8. Function Knob

a. PROG

Select to program Auto On time.
Coffeemaker can be programmed to automatically start brewing up to 24 hours in advance.

b. AUTO ON

Select to automatically start brewing coffee at the time you've programmed.

c. AUTO OFF

Select to program your coffeemaker to automatically shut off up to 4 hours after brewing.

d. BREW

Select to begin brew cycle when ON button is pressed.

e. CLOCK

Select to program time of day.

f. AUDIBLE TONE (not shown)

A tone sounds 5 times when brew cycle is complete (coffee may continue to stream from the filter for a few seconds after tone).

PROGRAMMING YOUR COFFEEMAKER

SETTING THE CLOCK

When the coffeemaker is plugged in, 12:00 will appear until you set the time.

Turn the Function Knob to **CLOCK**

Hold down the Hour or Minute button until the clock begins flashing. Press either button to select the desired time. Hold buttons down to scroll through the digits, or press and release to advance one digit at a time. When scrolling, the numbers will advance slowly and then speed up. When the number displayed approaches the desired time, press and release to advance one digit at a time. Be sure the PM indicator is on if a PM time is desired.

SETTING THE AUTO ON TIME

When you turn the Function Knob to Prog it displays a previously selected auto-on time, or the default time (12:00pm).

1. Turn the Function knob to **PROG**

Follow directions under SETTING THE CLOCK (above) to program your start-brew time.

2. Turn the Function knob to **AUTO ON**

LCD will display the current time.

3. Press and release **ON/OFF** button

A green light indicates that coffeemaker is in AUTO ON mode. A red light will come on when brew cycle begins. Both lights will go off when Keep Warm cycle ends.

NOTE: To start brew time at the same time the next day, simply make sure the Function Knob is on AUTO ON and press and release ON/OFF button once more. Green AUTO ON light will go on.

SETTING THE AUTO OFF TIME

Turn the Function Knob to **AUTO OFF**

Follow directions under SETTING THE CLOCK (above) to program your coffeemaker to shut off from 0 to 4 hours after brew cycle is finished.

BEFORE BREWING YOUR FIRST POT OF COFFEE

During the manufacturing process, dust can get trapped in your coffeemaker. We recommend flushing out the system before brewing your first pot of coffee. Simply fill the reservoir and power on the unit. (See steps #2 and #6 in MAKING COFFEE instructions, below). **DO NOT ADD COFFEE!**

Once you've done that, brew a pot of real coffee and get ready to enjoy Cuisinart at its best!

MAKING COFFEE

Follow instructions in "Before Brewing Your First Pot of Coffee" above.

1. Insert charcoal water filter

Follow directions for the preparation and insertion of the filter on page 8.

2. Fill the water reservoir

Open the reservoir cover by lifting it up. Pour in the desired amount of water using the water level indicator located at the side of the coffeemaker window.

3. Set preferences

- Push the 1-4 cup button if you are brewing fewer than 5 cups.
- Press Regular or Bold button to select flavor strength.*
- Turn the Carafe Temperature dial to low(L), medium(M), or high(H) and heater plate will keep coffee at the temperature you select.*

*Features will remain at selected settings until you change them.

4. Add the ground coffee

Remove the filter basket by grasping the handle and lifting straight up, and then place it on the countertop. Insert a #4 paper filter or permanent filter. Be sure that the paper filter is completely open and fully inserted in the basket. It may help to fold and flatten the seams of a paper filter beforehand. Add 1 level scoop of ground coffee per cup. Adjust the amount according to taste.

NOTE: The maximum capacity for ground coffee is 17 tablespoons for this coffeemaker. Exceeding this amount may cause overflow if the coffee is too finely ground.

Replace the filter basket in the filter basket holder and press firmly on cover to be sure it closes securely.

5. Before brewing coffee

Make sure the glass carafe is in position on the heating plate and the top cover is closed. Plug the cord into an electrical outlet.

6. Power unit

Turn the Function knob to BREW, press the ON/OFF button, and the red indicator light will turn on. Or, set the AUTO ON function (see page 7) and the green indicator will light.

7. After brewing

When the brewing cycle has been completed, five beeps will sound. Coffee will continue to stream from the filter for several seconds.

Once the coffee has finished brewing, stir it before serving to blend the flavors. The coffee at the bottom of the carafe will be somewhat stronger than the coffee at the top.

Note: Reservoir cover may be hot during and directly after brewing. Wait at least 10 minutes before opening.

Brew Pause™ Feature

This feature interrupts the flow of coffee from the basket to let you pour that first cup mid-brew. Because the flavor profile of coffee brewed at the start of a cycle differs from that brewed towards the end, be aware that using this feature will weaken the flavor strength of the finished pot.

NOTE: Removing carafe for more than 20 seconds may cause filter basket to overflow.

CHARCOAL WATER FILTER

Your coffeemaker comes with a charcoal water filter that eliminates chlorine, bad tastes and odors from tap water.

Inserting the Water Filter

- Remove the filter from polybag and soak it, fully immersed, in cold tap water for 15 minutes.
- Lift the water filter holder out of the water reservoir (see diagram, page 5).
- Press down on the filter compartment and pull toward you to open.
- Place filter into the holder and snap it closed. Be careful – improper placement can tear the filter skin.
- Flush filter by running cold tap water through holes in bottom of compartment for 10 seconds.
- Allow the filter to drain completely.
- Slide the water filter holder back into the channel in the water reservoir, pushing it down to the base of the unit.

NOTE: We recommend changing the water filter every 60 days or after 60 uses, and more often if you have hard water.

Replacement filters can be purchased in stores, by calling Cuisinart customer service, or at www.cuisinart.com.

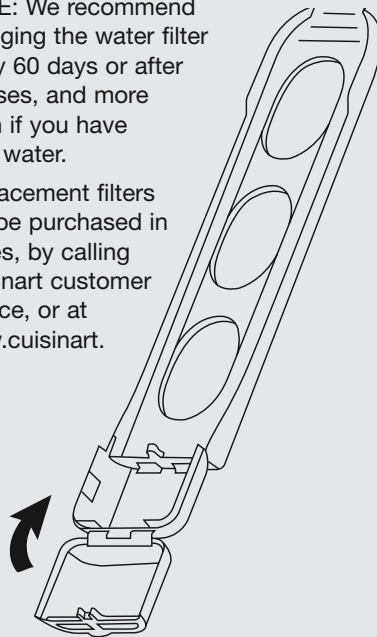

calcium deposits which form over time on the metal parts of the coffeemaker.

For best performance from your Brew Central® Coffeemaker, decalcify the base unit from time to time. The frequency depends upon the hardness of your tap water and how often you use the coffeemaker. The flashing Clean light will indicate when you should clean your coffeemaker.

If the Clean light begins to flash when the coffeemaker is turned on, it is telling you that the calcium buildup is interfering with the functioning of your coffeemaker and the flavor of your coffee. To clean, fill the water reservoir to capacity with a mixture of $\frac{1}{3}$ white vinegar and $\frac{2}{3}$ water. Press the Clean button. When the self clean light glows, turn the coffeemaker on by pressing the on/off button. The Clean light will shine steadily. The coffeemaker is now in clean mode. One cycle should be sufficient to adequately clean the coffeemaker. When the cycle is completed and the five beeps sound, the coffeemaker will shut off. Turn the coffeemaker on to see if the Clean light continues to flash. If it does, turn it off and then repeat the cleaning procedure with a fresh solution of vinegar and water.

If the Clean light no longer flashes, turn the coffeemaker off and then run one cycle of fresh cold water through the unit before using the unit again to brew coffee.

Notes on the Clean Function

Pressing the Clean button cancels all other settings. If it is pressed accidentally, press it again to return the coffeemaker to all its previous settings. Pressing On/Off will also exit the clean mode and turn the coffeemaker off.

WARRANTY

LIMITED THREE-YEAR WARRANTY

This warranty is available to consumers only. You are a consumer if you own a Cuisinart® Brew Central 14-Cup Programmable Coffeemaker that was purchased at retail for personal, family or household use. Except as otherwise required under applicable law, this warranty is not available to retailers or other commercial purchasers or owners.

We warrant that your Cuisinart® Brew Central 14-Cup Programmable Coffeemaker will be free of defects in materials and workmanship under normal home use for 3 years from the date of original purchase.

We suggest you complete and return the enclosed product registration card promptly to facilitate verification of the date of original purchase.

However, return of the product registration card does not eliminate the need for the consumer to maintain the original proof of purchase in order to obtain the warranty benefits. In the event that you do not have proof of purchase date, the purchase date for purposes of this warranty will be the date of manufacture.

If your Cuisinart® Brew Central 14-Cup Programmable Coffeemaker should prove to be defective within the warranty period, we will repair it, or if we think necessary, replace it. To obtain warranty service, simply call our toll-free number 1-800-726-0190 for additional information from our Customer Service Representatives, or send the defective product to Customer Service at Cuisinart, 150 Milford Road, East Windsor, NJ 08520.

To facilitate the speed and accuracy of your return, please enclose \$10.00 for shipping and handling of the product.

Please pay by check or money order (California residents need only supply proof of purchase and should call 1-800-726-0190 for shipping instructions).

NOTE: For added protection and secure handling of any Cuisinart® product that is being returned, we recommend you use a traceable, insured delivery service. Cuisinart cannot be held responsible for in-transit damage or for packages that are not delivered to us. Lost and/or damaged products are not covered under warranty. Please be sure to include your return address, daytime phone number, description of the product defect, product model number (located on bottom of product), original date of purchase, and any other information pertinent to the product's return.

Your Cuisinart® Brew Central 14-Cup Programmable Coffeemaker has been manufactured to the strictest specifications and has been designed for use with the authorized accessories and replacement parts.

This warranty expressly excludes any defects or damages caused by accessories, replacement parts, or repair service other than those that have been authorized by Cuisinart.

This warranty does not cover any damage caused by accident, misuse, shipment or other ordinary household use.

This warranty excludes all incidental or consequential damages. Some states do not allow the exclusion or limitation of these damages, so they may not apply to you.

CALIFORNIA RESIDENTS ONLY:

California law provides that for In-Warranty Service, California residents have the option of returning a nonconforming product (A) to the store where it was purchased or (B) to another retail store which sells Cuisinart products of the same type.

The retail store shall then, at its discretion, either repair the product, refer the consumer to an independent repair facility, replace the product, or refund the purchase price less the amount directly attributable to the consumer's prior usage of the product. If the above two options do not result in the appropriate relief to the consumer, the consumer may then take the product to an independent repair facility if service or repair can be economically accomplished. Cuisinart and not the consumer will be responsible for the reasonable cost of such service, repair, replacement, or refund for nonconforming products under warranty.

California residents may also, according to their preference, return nonconforming products directly to Cuisinart for repair, or if necessary, replacement, by calling our Consumer Service Center toll-free at 1-800-726-0190.

Cuisinart will be responsible for the cost of the repair, replacement, and shipping and handling for such products under warranty.

BEFORE RETURNING YOUR CUISINART PRODUCT

If you are experiencing problems with your Cuisinart® product, we suggest that you call our Cuisinart® Service Center at 1-800-726-0190 before returning the product serviced. If servicing is needed, a representative can confirm whether the product is under warranty and direct you to the nearest service location.

Important: If the nonconforming product is to be serviced by someone other than Cuisinart's Authorized Service Center, please remind the servicer to call our Consumer Service Center at 1-800-726-0190 to ensure that the problem is properly diagnosed, the product serviced with the correct parts, and the product is still under warranty.

Cuisinart®

SAVOR THE GOOD LIFE®



Coffeemakers



Food Processors



Toasters



Blenders



Cookware



Ice Cream Makers

Cuisinart offers an extensive assortment of top quality products to make life in the kitchen easier than ever. Try some of our other countertop appliances and cookware, and Savor the Good Life®.

www.cuisinart.com

©2008 Cuisinart
Cuisinart® is a registered
trademark of Cuisinart

Any trademarks or service marks of third parties used herein are the trademarks or service marks of their respective owners.

150 Milford Road
East Windsor, NJ 08520
Printed in China

08CU325

IB-8519