

This Owner's Manual is provided and hosted by [Appliance Factory Parts](#).



CUISINART DCC-2000 Owner's Manual

[Shop genuine replacement parts for CUISINART
DCC-2000](#)



[Find Your CUISINART Small Appliance Parts - Select From 213 Models](#)

----- Manual continues below -----

Cuisinart®



Coffee On Demand™

DCC-2000 Series

For your safety and continued enjoyment of this product, always read the instruction book carefully before using.

IMPORTANT SAFEGUARDS

When using electrical appliances, basic safety precautions should always be followed to reduce the risk of fire, electric shock and/or injury to persons, including the following:

1. READ ALL INSTRUCTIONS

2. Do not touch hot surfaces. Use handles and knobs.
3. To protect against electric shock, do not place cord, plug, or base unit in water or other liquids.
4. Close supervision is necessary when any appliance is used by or near children.
5. **Always unplug from outlet when not in use and before cleaning.** Allow to cool before putting on or taking off parts and before cleaning the appliance.
6. Do not operate any appliance with a damaged cord or plug or after the appliance malfunctions or has been dropped or damaged in any manner. Return appliance to the nearest Cuisinart Repair Center for examination, repair, or electrical or mechanical adjustment.
7. The use of accessory attachments not recommended by Cuisinart may cause injuries.
8. Do not use outdoors.
9. Do not let cord hang over edge of table or counter, or touch hot surface.

10. Do not place on or near a hot gas or electric burner, or in a heated oven.
11. Always fill water reservoir first, then plug cord into the wall outlet. To disconnect, turn controls to "off", then remove plug from wall outlet.
12. Do not use appliance for other than intended use.
13. Do not open lid during brewing to prevent injury.
14. Do not clean drip tray with cleansers, steel wool pads, or other abrasive materials.
15. **WARNING: TO REDUCE THE RISK OF FIRE OR ELECTRIC SHOCK, DO NOT REMOVE THE BASE PANEL. NO USER SERVICEABLE PARTS ARE INSIDE. REPAIR SHOULD BE DONE ONLY BY AUTHORIZED PERSONNEL.**

SAVE THESE INSTRUCTIONS

FOR HOUSEHOLD USE ONLY

WARNING: RISK OF FIRE OR ELECTRIC SHOCK



The lightning flash with arrowhead symbol, within an equilateral triangle, is intended to alert the user to the presence of uninsulated "dangerous voltage" within the product's enclosure that may be of sufficient magnitude to constitute a risk of fire or electric shock to persons.



The exclamation point within an equilateral triangle is intended to alert the user to the presence of important operating and maintenance (servicing) instructions in the literature accompanying the appliance.

SPECIAL CORD SET INSTRUCTIONS

A short power-supply cord is provided to reduce the risks resulting from becoming entangled in or tripping over a longer cord.

Longer extension cords are available and may be used if care is exercised in their use.

If a long extension cord is used, the marked electrical rating of the extension cord must be at least as great as the electrical rating of the appliance, and the longer cord should be arranged so that it will not drape over the countertop or tabletop where it can be pulled on by children or tripped over.

NOTICE

This appliance has a polarized plug (one blade is wider than the other). To reduce the risk of electric shock, this plug will fit in a polarized outlet only one way. If the plug does not fit fully in the outlet, reverse the plug. If it still does not fit, contact a qualified electrician. Do not modify the plug in any way.

OPERATING NOTICE

Clogging and backing up of water and/or coffee in the filter basket can occur under any or a combination of any of the following conditions: The use of too finely ground coffee, using two or more paper filters, using the gold tone filter in conjunction with a paper filter or not properly cleaning coffee grounds from the gold tone filter, or allowing coffee grounds to spill over the filter.

Caution: Never open the top cover during the brewing cycle, even if no water is draining from the filter basket, since extremely hot water/coffee can spill out from the filter basket and cause injury. If water/coffee is not draining from the filter basket during the brewing cycle, unplug the unit and wait 10 minutes before opening the top cover and checking the filter basket.

IMPORTANT UNPACKING INSTRUCTIONS

1. Place the box on a large, sturdy, flat surface.
2. Remove the instruction book and any other literature.
3. Turn the box so that the back side of the coffeemaker is down and slide the coffeemaker from the box.
4. After the coffeemaker has been removed, place the box out of the way and take the side polyfoam inserts away.
5. Remove the polybag covering the coffeemaker.

We suggest you save all packing materials in the event that future shipping of the machine is needed. Keep all plastic bags away from children.



TABLE OF CONTENTS

Important Safeguards	1
Unpacking Instructions	2
Introduction	3
The Quest for the Perfect Cup of Coffee	3
Features and Benefits	4-5
Control Panel	6
Programming Your Coffeemaker	7
Setting the Time	7
Programming the Auto On	7
Programming the Variable Auto Off	7
Making Coffee	7
Inserting the Water Filter	8
Cleaning and Maintenance	9
Warranty	9

INTRODUCTION

Cuisinart keeps making life easier! Your Coffee on Demand™ Coffeemaker eliminates the carafe, so all you or your guests have to do for a cup of fresh, hot, flavorful coffee is press a lever. A double-wall reservoir keeps up to 12 cups of coffee hot, and Cuisinart's easy-to-read Coffee Gauge™ lets you know how many cups are left. Get ready to enjoy pure coffee flavor, cup after cup, with Cuisinart.

THE QUEST FOR THE PERFECT CUP OF COFFEE

It is generally agreed that there are four basic elements critical to the perfect cup:

Element 1: Water

Coffee is 98% water. Often overlooked, the quality of the water is as important as the quality of the coffee. A good rule of thumb is that if your water doesn't taste good from the tap, it won't taste any better in your coffee. That's why Cuisinart has added a water filter to the Coffee On Demand™ Coffeemaker. The charcoal water filter removes chlorine, bad tastes and odors, for the purest cup of coffee every time.

Element 2: Coffee

While the bulk of the liquid is water, all of the flavor should be from the coffee. To achieve the same great quality cup of coffee you receive at a coffee bar, you need to use the same quality beans. If you choose to grind your own beans, buy the beans fresh and whole, only about a two-week supply at a time for maximum freshness. Once the coffee bean is broken, its flavor degrades very quickly. If it is not practical to buy small supplies, we recommend you separate larger amounts of beans into one- or two-week portions immediately after purchasing, and freeze them in airtight containers. The best way to maximize freshness is to minimize exposure to air, light and moisture. So, once removed from the freezer, beans should be maintained in a sealed container at room temperature, since damaging condensation occurs every time the beans are removed from the freezer or refrigerator. Note that some coffee experts advise against freezing dark-roast beans because this can cause the oils to coagulate, while other experts disagree. We suggest you experiment and decide for yourself.

Element 3: Grind

The grind is critical for proper flavor extraction. If the grind is too fine, overextraction and bitterness will result. Too fine a grind may also clog your filter. If grind is too coarse, the water will pass through too quickly and the desired flavors will not be extracted. We recommend a medium-fine grind.

Element 4: Proportion

The cups on the Cuisinart® coffeemaker are 5 ounces. Add the amount of ground coffee that corresponds to the number of cups being brewed. Many coffee bars and the Specialty Coffee Association of America recommend adding 2 rounded tablespoons of coffee per 6 ounces of water. Some coffee manufacturers recommend using one tablespoon per cup. We recommend using 1 tablespoon of ground coffee per cup, but use more or less to suit your taste.

NOTE: The maximum capacity for ground coffee is 15 tablespoons for this 12-cup coffeemaker. Exceeding these amounts may cause overflow if the coffee is too finely ground.

FEATURES AND BENEFITS

- 1. Reservoir Cover**
Flips back for easy filling.
- 2. Water Reservoir**
(see detailed drawing)
- 3. Coffee Reservoir**
(see detailed drawing)
- 4. Coffee Gauge™**
For determining amount of brewed coffee remaining in unit.
- 5. Showerhead (see detailed drawing)**
Distributes water evenly over coffee, reducing temperature loss as water passes through grounds.
- 6. Charcoal Water Filter (see detailed drawing)**
Charcoal water filter eliminates chlorine, bad tastes and odors from tap water.
- 7. Filter Basket (see detailed drawing)**
Holds a #4 paper filter or a permanent filter.
- 8. LCD Digital Clock**
Displays time of day and set time for automatic functions.
- 9. Function Knob**
Used to initiate programming of automatic functions – Auto On, Auto Off, Program, Clock, and Brew.
- 10. ON/OFF Knob**
Used to turn your coffeemaker on and off and programming your delayed brew.
- 11. 1-4 Cup Setting**
For brewing smaller pots of coffee. It provides 'double' heating of the water, so it is piping hot.

- 12. Hour and Minute Buttons**
Used to set time of day and set time for automatic functions.
- 13. Power Loss Back-up System (not shown)**
One-minute protection in case power fails, breaker trips or unit is unplugged.
- 14. Dispensing Lever**
For dispensing coffee into mug.
- 15. Ready Tone (not shown)**
Signals the end of the brew cycle with five beeps.
- 16. Drip Tray**
Removable tray with grate to remove any excess coffee that does not dispense into mug.

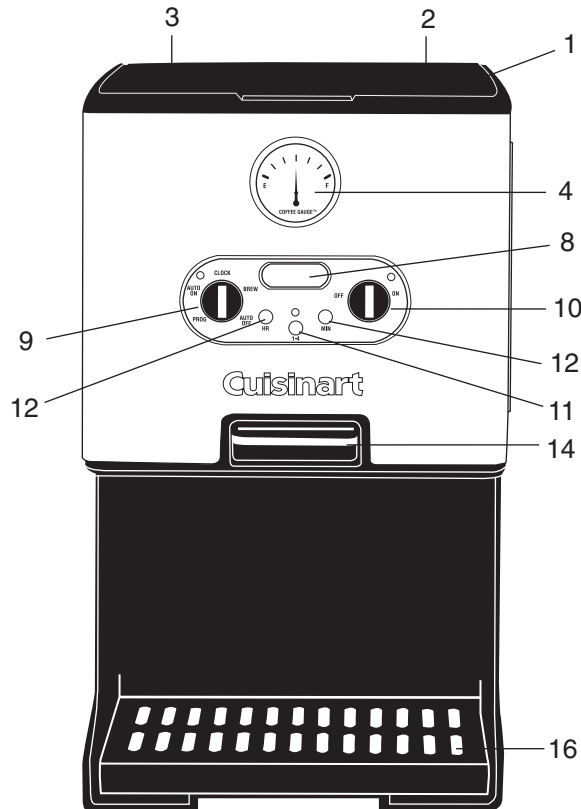

FEATURES AND BENEFITS

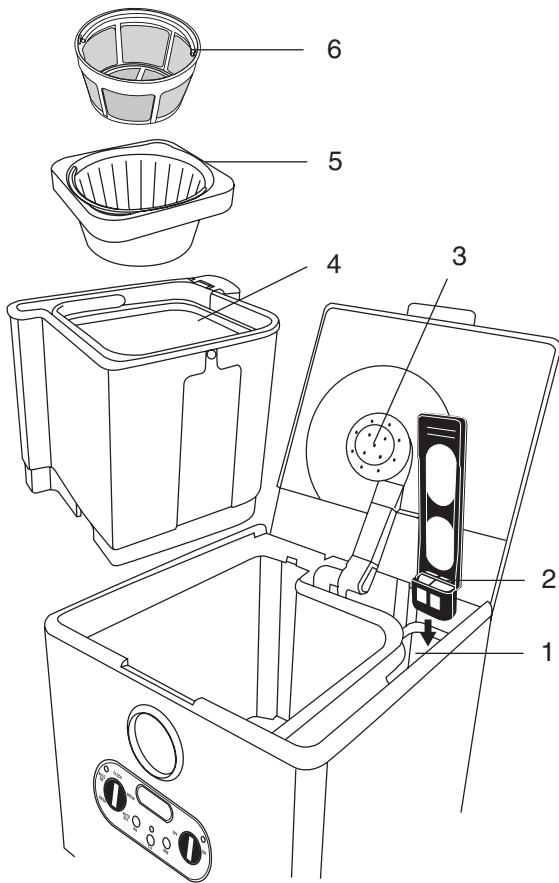

1. Water Reservoir

2. Charcoal Water Filter

Charcoal water filter eliminates chlorine, bad tastes and odors from tap water.

3. Showerhead

4. Coffee Reservoir

Removable double-wall reservoir keeps up to 12 cups of coffee hot for hours

5. Filter Basket

Holds our commercial style permanent filter or paper filter.

NOTE: FILTER BASKET HOLDER MUST BE IN PLACE FOR UNIT TO OPERATE CORRECTLY.

Removable for easy cleaning.

6. Gold Tone Cuisinart Commercial Style Filter

A note about filters: When using our permanent filter, be sure that the handle is positioned toward the front of the unit. If you do not, the handle may interfere with the flow of coffee into the filter basket.

Also note, using our permanent gold-tone filter will allow some fine coffee grounds to fall into the coffee carafe. This will appear as sediment in the carafe.

CONTROL PANEL

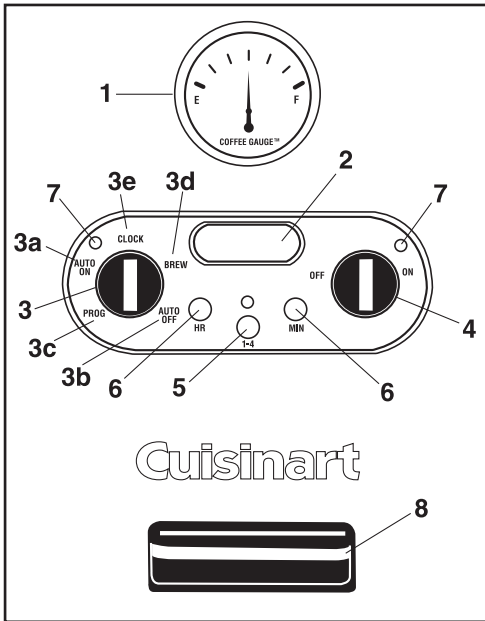

1. Coffee Gauge™

For determining amount of brewed coffee remaining in unit.

2. Clock Display

Displays time of day and auto on and off times.

3. Function Knob

For setting time of day, and auto on and auto off times.

a. Auto On

The Auto On feature is used to program the start time of the brew cycle. The auto on time can be set for any time, day or night. The "PM" indicator is displayed on the LCD for nighttime program times.

b. Auto Off

The Auto Off feature is used to shut off the coffeemaker at a preset time, anywhere from 0 to 4 hours.

c. Program Set

The Program Set function is used to set the time for the Auto On function.

d. Brew

The Brew function is used to start the brew cycle directly.

e. Clock Set

Used to program the time of day.

f. Audible Tone (not shown)

The Coffee on Demand™ Coffeemaker is equipped with an audible tone which will sound 5 times when the coffee has completed brewing.

4. On/Off Knob

Used to turn your coffeemaker on and off and for programming your delayed brew.

5. 1-4 Cup Setting Amounts

For brewing smaller pots of coffee – it provides 'double' heating of the water, so coffee is piping hot.

6. Hour and Minute Buttons

For use in setting hour and minute for time of day, auto on time, and auto off time.

7. On and Auto On Indicator Lights

8. Dispensing Lever

For dispensing coffee into mug.

PROGRAMMING YOUR COFFEEMAKER

TO BREW COFFEE

1. Turn the function knob to “Brew.”
2. Turn the On/Off knob to “On” and release. The red “On” indicator light will illuminate and brew cycle will begin.

TO TURN THE COFFEEMAKER OFF

Simply turn the On/Off function knob to “Off” and release.

NOTE: To program the coffeemaker to shut off automatically, see **To program the Variable Auto Off** instructions below.

PROGRAMMING YOUR COFFEEMAKER FOR DELAYED BREW TIME

To set the time:

1. Turn the function knob to “Clock”.
 - a. **Set Hour:** Press and hold the “Hour” button to scroll through numbers quickly. When number displayed approaches the desired setting, press and release (pulse) the button to advance one digit at a time. After setting the correct hour, the default will be the last time set unless power is shut off.

NOTE: When the number count passes 12, the PM light will be displayed on the LCD.

- b. **Set Minutes:** Press and hold the “Minute” button to scroll through numbers quickly. When number displayed approaches the desired setting, press and release (pulse) the button to advance one digit at a time. After setting the correct minute, the default will be the last time set unless power is shut off. To finish setting time, turn the FUNCTION KNOB to any other setting or simply wait until the numerals stop blinking.

To program the Auto On (brew start time)

1. Turn the function knob to “Prog.”
2. Set the time you want coffee to begin brewing by using the minute and hour push-buttons. Follow the same instructions you used to set the time of day, in the **To set the time** section above.

3. Turn the function knob to “Auto On.” LCD will display the current time.
4. Turn the On/Off knob to “On” and release. The green indicator light will come on to remind you that the programming function is in use. At the programmed time, the red indicator will come on as well, indicating that the brew cycle is starting. Both lights will go off when keep warm cycle ends.

NOTE: To reactivate the auto-on feature to start brew cycle at the same time another day, simply turn the On/Off function knob to “On” and release. The green “auto-on” light will illuminate.

To program the Variable Auto Off:

1. Turn the function knob to “Auto Off.” Press and hold the “Hour” button for 2 seconds. The clock display will start blinking.
2. Program the coffeemaker to shut off from zero to four hours after brew cycle is finished by using the “Hour” and “Minute” buttons (see “To set the time”).

1 - 4 Cup Setting:

The 1- 4 cup setting button is used when you make small amounts of coffee. The 1-4 setting basically ‘double heats’ the water, making your smaller amount piping hot.

To use: When making a smaller amount, press the 1-4 button on the control panel after turning on the unit.

Power Loss Back-up

One-minute protection in case a breaker trips, the unit is unplugged, or the power fails. It holds all programmed information, including time of day, auto on time and auto off time.

MAKING COFFEE

Before you make the first batch of coffee in your new Cuisinart® Coffee On Demand™ Coffeemaker, we recommend operating the coffeemaker once using only water and a paper filter. This will remove any dust or residues that remain in the system from the manufacturing process.

1. Insert the Water Filter:

- a. Remove the filter from polybag and soak in cold tap water for 15 minutes.
- b. Remove the water filter holder from

the coffeemaker by lifting it out of the reservoir area with your thumb and forefinger.

- c. Grasp stem in one hand. Using thumb of other hand, gently press down and pull toward you. Compartment will flip open.
- d. Place the filter in the holder and close the water filter holder; you will hear a snap indicating it is in place.

NOTE: Caution must be used when inserting the charcoal filter. Improper placement in the holder can cause tearing of the filter skin.

- e. Hold the filter under cold running tap water for 10 seconds to flush. You should place the hole openings in the side of the unit directly under the water stream.
- f. Allow the filter to drain completely.
- g. Replace the water filter holder in the reservoir area of the coffeemaker, pushing it all the way down to the base of the unit, along the reservoir wall.

NOTE: We recommend changing the water filter every 60 days or 60 uses, more often if you have hard water.

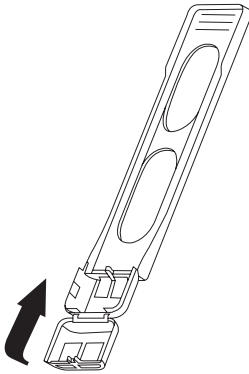

Replacement water filters can be purchased in stores or by calling customer service or through the Cuisinart web site.

2. Fill the water reservoir:

When filling the coffeemaker with water, refer to the water window on the side of the unit and fill to the desired number of cups. Be sure to add a small amount of extra

water to account for the amount of water lost in wetting the grounds and lost as steam during the brewing process.

3. Add the ground coffee:

Remove the filter basket by grasping the handle and lifting straight up, and then place it on the countertop. Insert a #4 paper filter or permanent filter. Be sure that the paper filter is completely open and fully inserted in the basket. It may help to fold and flatten the seams of a paper filter beforehand. Add the desired amount of ground coffee, corresponding to the number of cups being brewed. Many coffee bars and the Specialty Coffee Association of America recommend adding 2 rounded tablespoons of coffee per 6 ounces of water. Some coffee manufacturers recommend using 1 tablespoon per cup. We recommend using 1 tablespoon of ground coffee per cup, but use more or less to suit your taste.

NOTE: The maximum capacity for ground coffee is 15 tablespoons for this 12-cup coffeemaker. Exceeding this amount may cause overflow if the coffee is too finely ground.

Replace the filter basket in the filter basket holder, making sure the coffee reservoir is in place. Flip the lid closed, and press firmly to be sure that it closes securely.

4. Power unit:

Plug the cord into an electrical outlet. Turn the function knob to brew, turn the On/Off knob to "On" and release. The red indicator light will turn on. Or, set the Auto On function and the green indicator will light.

CLEANING AND MAINTENANCE

Always turn coffeemaker OFF and remove the plug from the electrical outlet before cleaning.

Lift up the reservoir cover. Remove and discard the filter and ground coffee.

WARNING

Caution: The reservoir contains hot coffee. Allow to cool before lifting.

Remove the brew basket and coffee reservoir. These can be washed in warm, soapy water and rinsed thoroughly, or cleaned in the upper rack of the dishwasher. Dry all parts after use.

Do not put any water in the unit once the filter basket and coffee reservoir have been removed. Wipe the area under the reservoir with a damp cloth.

Remove drip tray and wash with warm soapy water and rinse thoroughly, or place in a dishwasher.

Do not use any scouring agents or harsh cleansers on any part of the coffeemaker.

Never immerse base unit in water or other liquid. To clean base, simply wipe with a clean, damp cloth and dry before storing. Fingerprints and other blemishes on the stainless steel housing can be washed off with soap and water or a nonabrasive cleaning solution. Never use rough, abrasive materials or cleansers to clean the warming plate. Do not dry the inside of the water reservoir with a cloth, as lint may remain.

DECALCIFICATION

Decalcification refers to removing the calcium deposits which form over time on the metal parts of the coffeemaker.

For best performance from your coffeemaker, decalcify the base unit from time to time. The frequency depends upon the hardness of your tap water and how often you use the coffeemaker.

To clean, fill the water reservoir to capacity with a mixture of $\frac{1}{2}$ white vinegar and $\frac{1}{2}$ water. Turn the coffeemaker on by turning the ON/OFF knob. One cycle should be sufficient to adequately clean the coffeemaker. When

the cycle is completed and the five beeps sound, turn coffeemaker off. Repeat operation, this time using fresh cold water.

WARRANTY

LIMITED THREE-YEAR WARRANTY

This warranty supersedes all previous warranties on the Cuisinart® Coffee On Demand™ Coffeemaker.

This warranty is available to consumers only. You are a consumer if you own a Cuisinart® Coffee On Demand™ Coffeemaker that was purchased at retail for personal, family or household use. Except as otherwise required under applicable state law, this warranty is not available to retailers or other commercial purchasers or owners.

We warrant that your Cuisinart® Coffee On Demand™ Coffeemaker will be free of defects in material or workmanship under normal home use for three years from the date of original purchase.

We suggest that you complete and return the enclosed warranty registration card promptly to facilitate verification of the date of original purchase. However, return of the warranty registration is not a condition of these warranties.

If your coffeemaker should prove to be defective within the warranty period, we will repair it (or, if we think it necessary, replace it) without charge to you. To obtain warranty service, please call our Consumer Service Center toll-free at 800-726-0190 or write to:

Cuisinart
150 Milford Road
East Windsor, NJ 08520

To facilitate the speed and accuracy of your return, please also enclose \$10.00 for shipping and handling of the product (California residents need only supply proof of purchase and should call 1-800-726-0190 for shipping instructions). Please also be sure to include a return address, description of the product defect, product serial number, and any other information pertinent to the product's return. Please pay by check or money order.

NOTE: For added protection and secure handling of any Cuisinart® product that is being returned, we recommend you use a traceable, insured delivery service. Cuisinart cannot be held responsible for in-transit damage or for packages that are not delivered to us. Lost and/or damaged products are not covered under warranty.

Your Cuisinart® coffeemaker has been manufactured to strict specifications and has been designed for use with the Cuisinart® coffeemaker authorized accessories and replacement parts for your model. These warranties expressly exclude any defects or damages caused by accessories, replacement parts or repair service other than those that have been authorized by Cuisinart.

These warranties exclude all incidental or consequential damages. Some states do not allow the exclusion of or limitation of incidental or consequential damages, so the foregoing limitation or exclusion may not apply to you.

CALIFORNIA RESIDENTS ONLY

California law provides that for In-Warranty Service, California residents have the option of returning a nonconforming product (A) to the store where it was purchased or (B) to another retail store which sells Cuisinart products of the same type. The retail store shall then, according to its preference, either repair the product, refer the consumer to an independent repair facility, replace the product, or refund the purchase price less the amount directly attributable to the consumer's prior usage of the product. If either of the above two options does not result in the appropriate relief to the consumer, the consumer may then take the product to an independent repair facility if service or repair can be economically accomplished. Cuisinart and not the consumer will be responsible for the reasonable cost of such service, repair, replacement, or refund for nonconforming products under warranty.

California residents may also, according to their preference, return nonconforming products directly to Cuisinart for repair or, if necessary, replacement by calling our Consumer Service Center toll-free at 800-726-0190. Cuisinart will be responsible for the cost of the repair, replacement, and shipping and handling for such nonconforming products under warranty.

BEFORE RETURNING YOUR CUISINART PRODUCT

Important: If the nonconforming product is to be serviced by someone other than Cuisinart's Authorized Service Center, please remind the servicer to call our Consumer Service Center to ensure that the problem is properly diagnosed, the product serviced with the correct parts, and to ensure that the product is still under warranty.

Cuisinart®

SAVOR THE GOOD LIFE®



Coffeemakers



Food Processors



Toaster Ovens



Blenders



Cookware



Ice Cream Makers

Cuisinart offers an extensive assortment of top quality products to make life in the kitchen easier than ever. Try some of our other countertop appliances and cookware, and Savor the Good Life®.

www.cuisinart.com

©2005 Cuisinart
Cuisinart® is a registered
trademark of Cuisinart
150 Milford Road
East Windsor, NJ 08520
Printed in China
05CU26008

U IB-5528

Version no.: DCC2000 IB-5528
SIZE: 152mm(W) x 204mm(H) Total Pages : 12pcs
Material: Cover:157gsm Matt Artpaper Inside: 120gsm Gloss Artpaper
Coating: Varnishing In Cover Page
Color: Cover: 4C + 1C (Black) Inside: 1C + 1C (Black)
Date: 03/30/05
P. O.: 0503000 (00/00/2005_OP)

 新成分色製版公司
Classic Graphic Arts Company
Tel: 2357 0071 Fax: 2357 0318