



---

## STAINLESS STEEL BUILT-IN GAS GRILL

MODEL #s: 750-0593 / 740-0593    LOWE'S ITEM #s: 168932 / 168931

---

Jenn-Air is a Trademark of the Maytag Corporation and is used under license to Lowe's Companies, Incorporated.

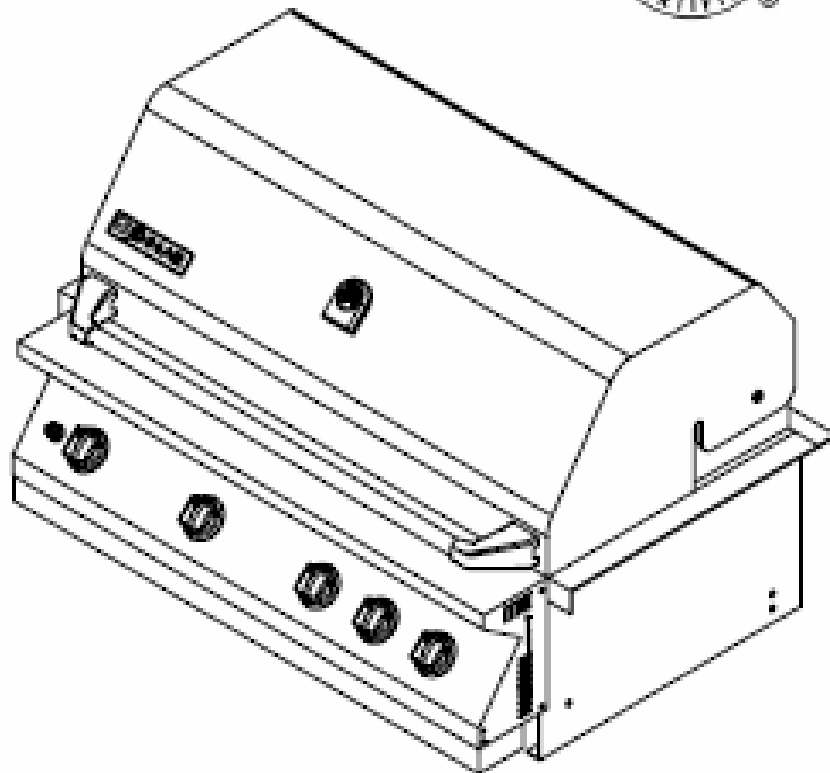

FOR OUTDOOR USE ONLY

K20Y07PN-2



PLEASE CONTACT 1-800-554-5799 FOR ASSISTANCE  
DO NOT RETURN TO PLACE OF PURCHASE

# TABLE OF CONTENTS

SECTION ONE		SECTION FIVE	
Safety Instructions	1-4	Exploded View Model 750-0593	24
Placement of the Grill	4	Parts List Model 750-0593	25
SECTION TWO		Exploded View Model 740-0593	26
Model Specifications	5	Parts List Model 740-0593	27
Island Construction	6-7	SECTION SIX	
Front View of Opening	8	Grilling Hints	28
Side View of Opening	9	Grill Cooking Chart	28-30
SECTION THREE		Grill Recipe Suggestions	31-32
Battery Installation	10	SECTION SEVEN	
LP Gas Hook Up	11	Limited Warranty	33
Propane Tank Assembly	12		
Installation of NG Regulator	13		
Natural Gas Hook-Up	14		
SECTION FOUR			
Leak Testing	15		
Installer Final Checklist	16		
Operating Instructions	17-18		
Lighting Instructions	19		
Lighting Illustrations	20		
To Match Light the Grill	21		
Care and Maintenance	22		
Troubleshooting	23		



## **WARNING**

To reduce the risk of fire, burn hazard or other injury, read this Care and Use Manual carefully and completely before using your grill.

**CONSUMER: RETAIN THIS MANUAL FOR FUTURE REFERENCE**

**INSTALLER: LEAVE THIS MANUAL WITH CONSUMER**

# SAFETY INSTRUCTIONS

## RECOGNIZED SAFETY SYMBOLS, WORDS AND LABELS

 **WARNING**

**WARNING** – Hazards or unsafe practices which COULD result in severe personal injury or death.

 **CAUTION**

**CAUTION** – Hazards or unsafe practices which COULD result in minor personal injury.

 **WARNING**

Do not try lighting this appliance without first reading the “LIGHTING INSTRUCTIONS” section of this manual.

 **WARNING**

Spiders and insects can nest inside the burners of the grill and disrupt gas flow. This very dangerous condition could cause a fire behind the valve panel, thereby damaging the grill and making it unsafe for operation.  
Inspect the grill at least twice a year.

 **WARNING**

1. Do not store spare liquid propane cylinders under or near this appliance.
2. Never fill the cylinder beyond 80 percent capacity.
3. If the information above is not followed exactly, a fire resulting in death or serious injury could occur.

 **WARNING**

Never attempt to use damaged or obstructed equipment. See your local liquid propane dealer for repair.

 **WARNING**

Check all gas supply fittings for leaks before each use. Do not use the grill until all connections have been checked and do not leak. Do not smoke while leak testing. Never leak test with an open flame.

 **WARNING**

1. Do not store or use gasoline or other flammable vapors and liquids in the vicinity of this or any other appliance.
2. An LP cylinder not connected for use shall not be stored in the vicinity of this or any other appliance.

 **WARNING**

- If you smell gas:
1. Shut off gas to the appliance.
  2. Extinguish any open flame.
  3. Open lid.
  4. If odor continues, keep away from the appliance and immediately call your gas supplier or your fire department.

 **WARNING**

The rotisserie motor is equipped with a plug and should be plugged directly into a properly grounded receptacle in accordance with local codes or, in the absence of local codes, with the National Electrical Code, ANSI/NFPA 70, or the Canadian Electrical Code, CSA C22.1. DO NOT cut or remove the grounding prong from this plug. Keep any electrical supply cord and the fuel supply hose away from any heated surface. Keep the rotisserie motor electric cord away from the heated surfaces of the grill. When not in use remove and store the motor in a dry location.

 **WARNING**

**You must use an OPD gas tank, which offers an Overfill Prevention Device.**

This safety feature prevents the tank from being overfilled, which can cause malfunction of the LP gas tank, regulator and/or grill.

# SAFETY INSTRUCTIONS

 **WARNING**

Do not use the grill if the odor of gas is present. Contact customer service at 1-800-554-5799.

 **WARNING**

When lighting, keep your face and hands as far away from the grill as possible.

 **WARNING**

Do not install this unit into combustible enclosures. There should be a minimum clearance of 24 inches from all sides to combustible materials. Outdoor cooking appliance shall not be used under overhead combustible construction.

 **WARNING**

Keep any electrical supply cord away from any heated surface.

 **CAUTION**

Burner adjustments should only be performed after the burners have cooled.

 **CAUTION**

When using a match to light the grill make sure to use the attached lighting rod.

 **CAUTION**

When using the rotisserie burner, remove the warming rack. High heat from the burner may cause the warming rack to bend.

 **CAUTION**

Before cleaning, make sure the gas supply and control knobs are in the "OFF" position and the burners have cooled.

 **WARNING**

Failure to properly place the burner over the orifice could cause a fire to occur behind and beneath the valve panel, thereby damaging the grill and making it unsafe to operate.

 **WARNING**

Do not leave the grill unattended while cooking.

 **WARNING**

Always check for leaks after every LP tank change.

## Model 750-0593 Natural Gas Grill

 **WARNING**

1. The outdoor cooking gas appliance and its individual shutoff valve must be disconnected from the gas supply piping system during any pressure testing of that system at test pressure in excess of 1/2 psi (3.5 kpa).
2. The outdoor cooking gas appliance must be isolated from the gas supply piping system by closing its individual manual shutoff valve during any pressure testing of the gas supply piping system at test pressures equal to or less 1/2 psi (3.5 kpa).

## Model 740-0593 LP Gas Grill

 **WARNING**

1. Do not store spare LP gas cylinders under or near this appliance.
2. Never fill the cylinder beyond 80 percent capacity.
3. If the information above is not followed exactly, a fire resulting in death or serious injury could occur.

# SAFETY INSTRUCTIONS



## **WARNING**

Do not try lighting this appliance without first reading the "LIGHTING INSTRUCTIONS" section of this manual.

## **TESTED IN ACCORDANCE WITH ANSI Z21.58-2007 and CSA 1.6-2007 STANDARD FOR OUTDOOR COOKING GAS APPLIANCES. THIS GRILL IS FOR OUTDOOR USE ONLY.**

Check your local building codes for the proper method of installation. In the absence of local codes, this unit should be installed in accordance with the National Fuel Gas Code ANSI Z223.1/NFPA 54, Storage and Handling of Liquefied Petroleum Gases, ANSI/NFPA B149.2 or CSA B149.1 Natural Gas and Propane Installation Code, and the National Electrical Code, ANSI/NFPA 70.



## **CALIFORNIA PROPOSITION 65-WARNING**

The burning of gas fuel generates some byproducts, which are known by the State of California to cause cancer or reproductive harm. To minimize exposure to these substances, always operate this unit according to the care and use manual, ensuring you provide good ventilation when cooking with gas.

## **SAFETY PRACTICES TO AVOID PERSONAL INJURY**

When properly cared for, your grill will provide safe, reliable service for many years. However, extreme care must be used as the grill produces intense heat that can increase accident potential. When using this appliance, basic safety practices must be followed, including the following:

Do not repair or replace any part of the grill unless specifically recommended in this manual. All other service should be referred to a qualified technician.

This grill is not intended to be installed in or on recreational vehicles or boats.

Children should not be left alone or unattended in an area where the grill is being used. Do not allow them to sit, stand or play in or around the grill at any time.

Do not store items of interest to children around or below the grill.

Do not permit clothing, pot holders or other flammable materials to come in contact with or too close to any grate, burner or hot surface until it has cooled. The fabric could ignite and cause personal injury.

For personal safety, wear proper apparel. Loose fitting garments or sleeves should never be worn while using this appliance. Some synthetic fabrics are highly flammable and should not be worn while cooking.

Only certain types of glass, heat-proof glass ceramic, earthenware, or other glazed utensils are suitable for grill use. Other types of materials may shatter with sudden temperature changes. Use only low or medium heat settings in accordance with the manufacturer's guidelines.

Do not heat unopened food containers. A build-up of pressure may cause the containers to burst.

Use a covered hand when opening the grill lid.

Never lean over an open grill.

When lighting a burner, pay close attention to what you are doing. Make certain you are aware of which burner you are lighting, so your body and clothing remain clear of open flames.

# SAFETY INSTRUCTIONS

When using the grill, do not touch the grill rack, burner grate or immediate surroundings as these areas become extremely hot and could cause burns. Use only dry potholders. Moist or damp potholders on hot surfaces may cause steam burns. Do not use a towel or bulky cloth in place of potholders. Do not allow potholders to touch hot portions of the grill rack.

Grease is flammable. Let hot grease cool before attempting to handle it. Do not allow grease deposits to collect in the grease tray at the bottom of the grill's firebox. Clean the grease tray often.

Do not use aluminum foil to line the grill racks or grill bottom. This can severely upset combustion air flow or trap excessive heat in the control area.

For proper lighting and performance of the burners, keep the burner ports clean. It is necessary to clean them periodically for optimum performance. The burners will only operate in one position and must be mounted correctly for safe operation.

Clean the grill with caution. To avoid steam burns, do not use a wet sponge or cloth to clean the grill while it is hot. Some cleaners produce noxious fumes or can ignite if applied to a hot surface.



## INSECT WARNING

Spiders and insects can nest inside the burners of this and other grills, which could disrupt gas flow. This dangerous condition could cause a fire behind and beneath the valve panel, damaging the grill and making it unsafe to operate.

Inspect the grill at least twice a year.

Never use a dented or rusty propane cylinder.

Turn off grill controls and make certain the grill is cool before using any type of aerosol cleaner on or around the grill. The chemical that produces the spraying action could, in the presence of heat, ignite or cause metal parts to corrode.

Do not use the grill to cook excessively fatty meats or other products which promote flare-ups.

Do not operate the grill under unprotected combustible constructions. Use only in well ventilated areas. Do not use in buildings, garages, sheds, breezeways or other such enclosed areas.

This unit is intended for outdoor use only.

Keep the areas surrounding the grill free from combustible materials including, fluids, trash, and vapors such as gasoline or charcoal lighter fluid. Do not obstruct the flow of combustion and ventilation air.

Do not use briquettes of any kind in the grill.

The 750-0593 and 740-0593 grills are designed for optimum performance without the use of briquettes. Do not place briquettes on the flame tamers as this will block the vent to the grill burners. Adding briquettes can damage ignition components, thus voiding the warranty.

Keep the back of the cart free and clear from debris. Keep electrical supply cords and the rotisserie motor cord away from heated areas of the grill.

Never use the grill in extremely windy conditions. If located in a consistently windy area (oceanfront, mountaintop, etc.), a windbreak will be required. Always adhere to the clearance specifications.

# PLACEMENT OF THE GRILL



## WARNING

Do not install this unit into combustible enclosures. There should be a minimum clearance of at least 24 inches from all sides to combustible materials.

## LOCATION

When determining a suitable location take into account concerns such as exposure to wind, proximity to traffic paths, and keeping gas supply lines as short as possible.

Place the grill in well-ventilated areas. Never locate the grill in a building, garage, breezeway, shed or other such enclosed areas. During heavy use, the grill will produce a lot of smoke.

# GRILL SPECIFICATIONS

<b>Description</b>	<b>750-0593 and 740-0593</b>
Cutout Width	33 in. (83.82 cm)
Cutout Depth	21 in. (53.34 cm)
Cutout Height	11 in. (27.94 cm)
Gas Requirements	Natural Gas: Standard residential 1/2 in. (1.3 cm) ID gas service line. Natural gas hose/regulator assembly included with quick-connect fitting for attachment to house natural gas line.
	Liquid Propane: Supplied with hose/regulator assembly for connection to standard 5 gal, 20 lb. liquid propane gas cylinder with Type 1, QCC-1 connection.
Grill Burners	4 Stainless Steel main burners. Infra-red rear rotisserie burner.
BTU Ratings	Main burners 48,000 BTU/Hr. <u>Rear burners 10,000 BTU/Hr.</u> Total 58,000 BTU/Hr.
Approximate Shipping Weight	150 lbs.

# Island Construction

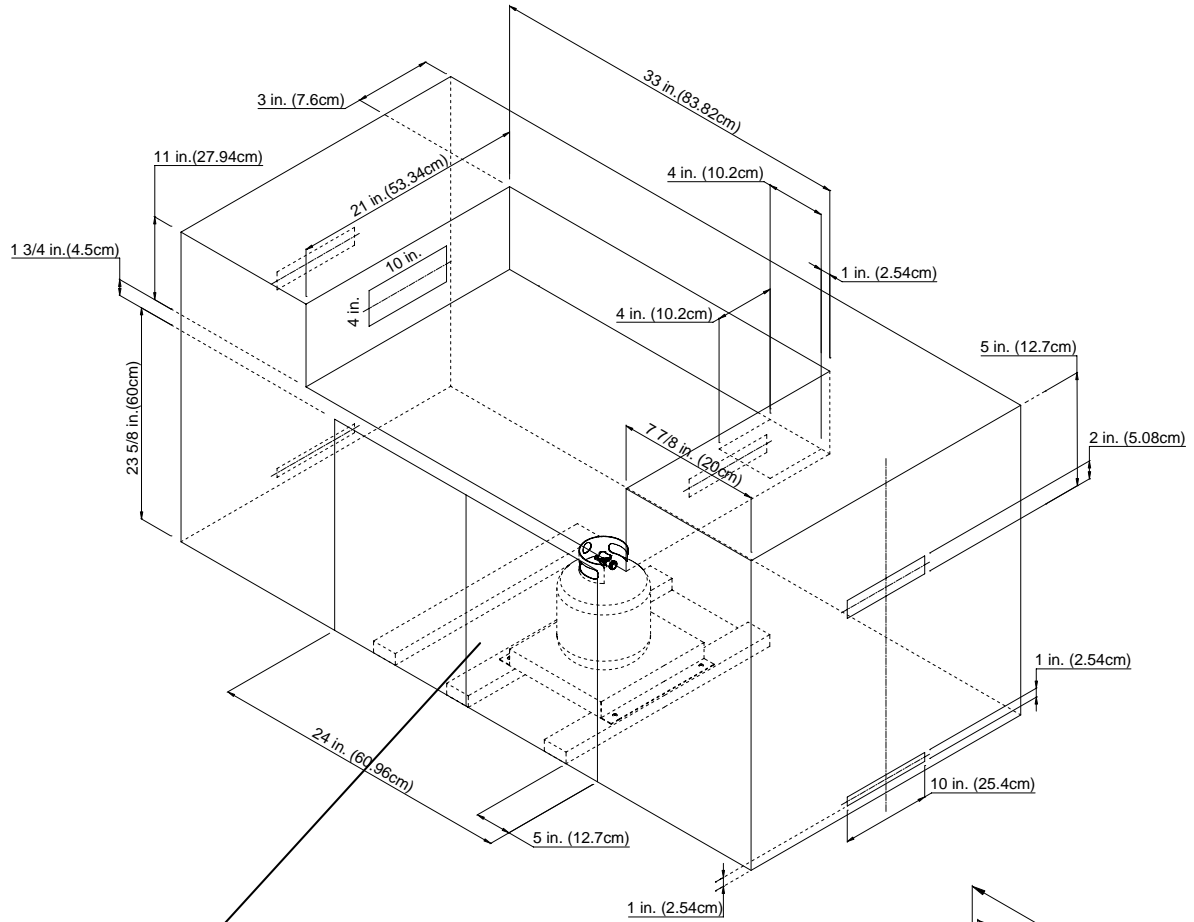

**⚠ WARNING**  
 Do not install this unit into combustible enclosures. There should be a minimum clearance of at least 24in. from all sides to combustible materials.

Island cutout dimensions for Jenn-Air 4 burner LP and NG built-in grills:  
 Width 33 inches  
 Depth 21 inches  
 Height 11 inches  
 Tank bolt dimension for Jenn-Air 4 burner LP  
 Tank bolt type: 1/2 inches-12UNC  
 Tank bolt length: 9/20 inches

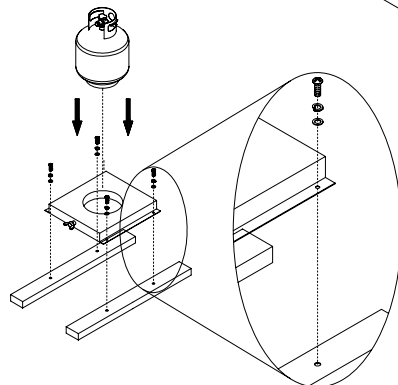
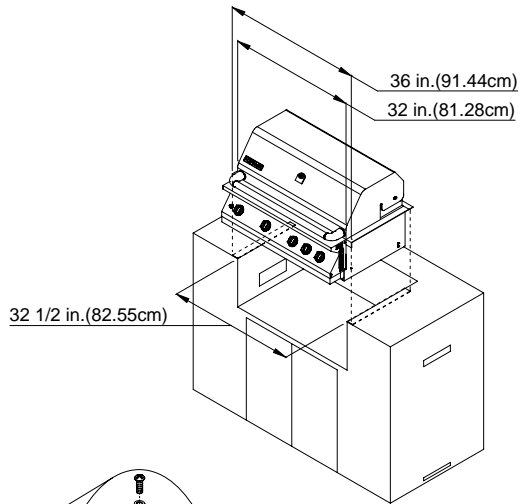

Non-Combustible material needs to be used for built-in enclosure. The proper selection of material could be brick, firewall or steel.

Never use wood or any combustible material for built-in enclosure.



# Island Construction

740-0593

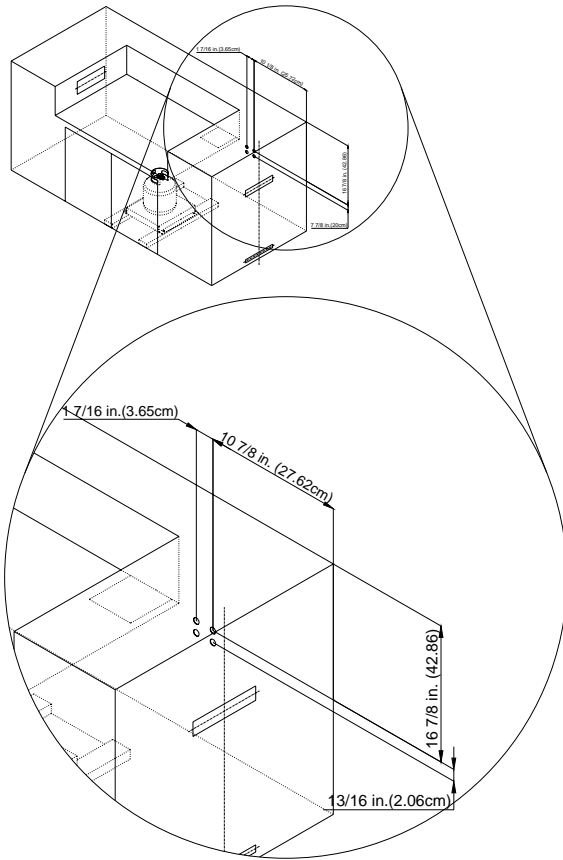

Measurements shown are for attaching the LP regulator to the island.

750-0593

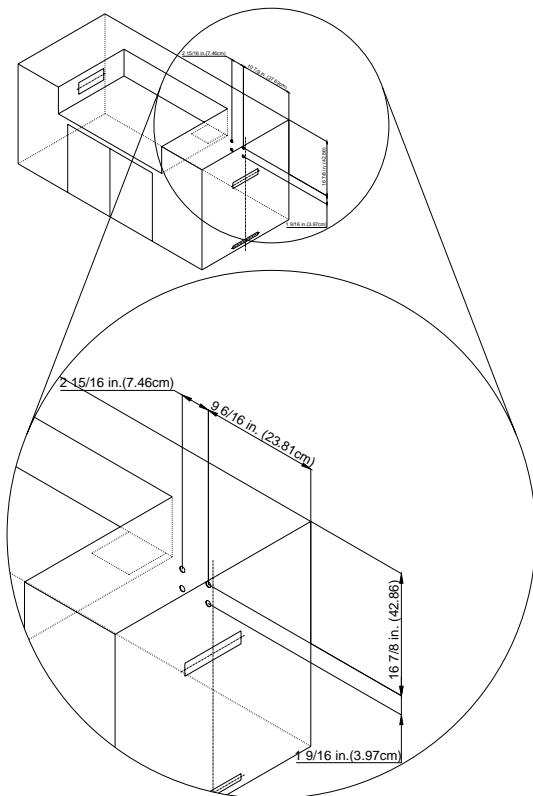

Measurements shown are for attaching the NG regulator to the island.

# FRONT VIEW FOR BUILT-IN OPENING

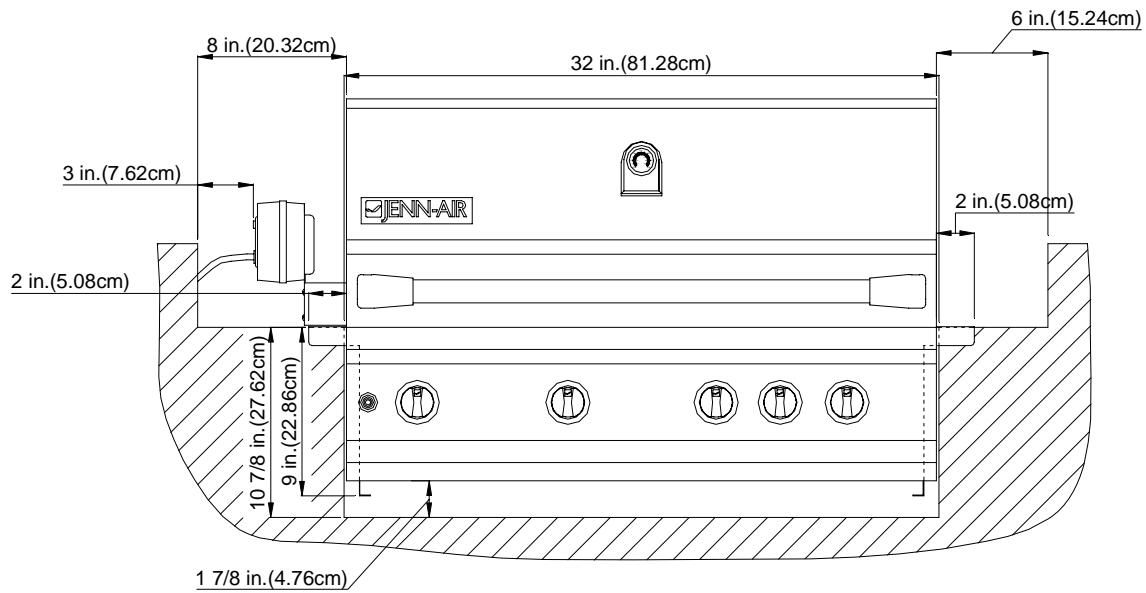

The following are minimum dimensions necessary to install the Jenn-Air built-in 4 burner grills.

Width of grill head: 32 in.

Depth for grill control panel: 10 7/8 in.

Combustion Gap below control panel: 1 7/8 in.

- A minimum of 6 in. clearance is needed from the right side of the grill firebox to non-combustible materials. The rotisserie motor is located on the left side of the grill firebox.
- A minimum of 8 in. clearance is required between the grill lid and any surrounding material to allow for proper functioning of the rotisserie motor.

# SIDE VIEW FOR BUILT-IN OPENING

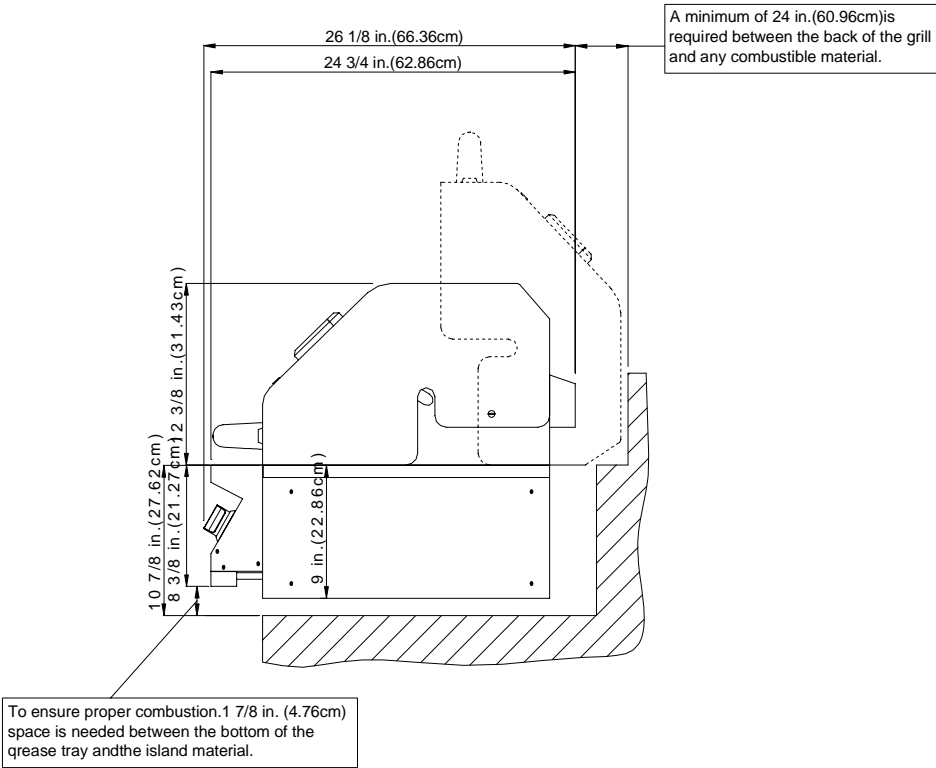

The following are minimum clearances necessary around the Jenn-Air built-in 4 burner grills.

Rear Clearance: 24 in. to combustible materials

Combustion gap below control panel: 1 3/4 in.

## BATTERY INSTALLATION

1. Unscrew the ignition button housing by turning counterclockwise.
2. Insert the battery into the housing with the positive (+) terminal facing outward.
3. Replace the ignition button housing after the battery has been installed.

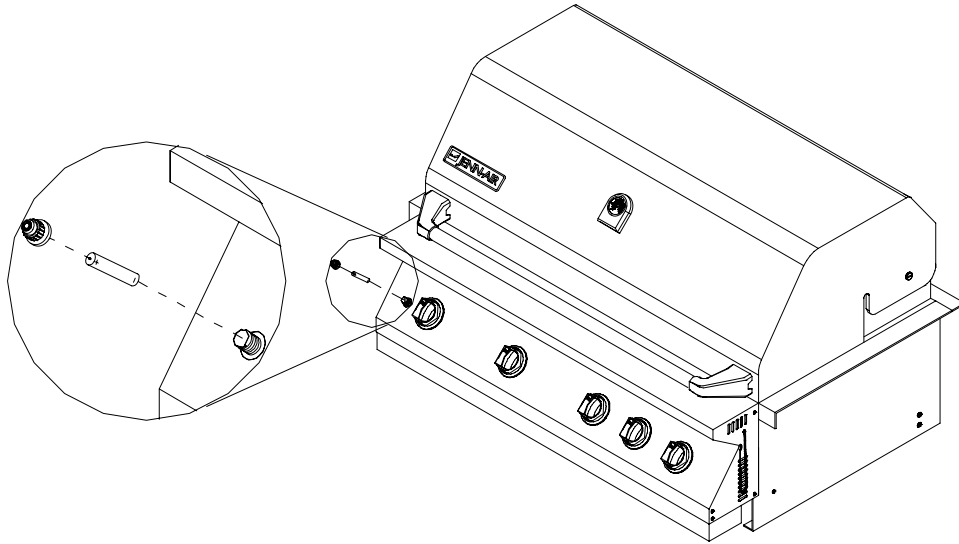

## LP GAS HOOK-UP

Only the pressure regulator and hose assembly supplied with the grill should be used. Any replacement pressure regulator and hose assembly must be specified by the grill manufacturer.

This is a liquid propane configured grill. Do not attempt to use a natural gas supply.

Total gas consumption (per hour) of 740-0593 grill with all burners on "IGNITE / HI":

Main burners	48,000 BTU/Hr.
Rotisserie burner	10,000 BTU/Hr
Total	58,000 BTU/Hr.

The installation of this appliance must conform with local codes or, in the absence of local codes, to the national fuel gas code, ANSI Z223.1. Installation in Canada must be in accordance with the Standard CAN/CSA-B149.2 (installation code for gas burning appliances and equipment) and local codes.

### LP GAS CYLINDER REQUIREMENTS (20lb. Cylinder)

A dented or rusty LP gas cylinder may be hazardous and should be checked by your LP supplier. Never use a cylinder with a damaged valve. The LP gas cylinder must be constructed and marked in accordance with the specifications for LP gas cylinders of the U.S. Department of Transportation (DOT), or the National Standard of Canada, CAN/CSA-B339, Cylinders, Spheres and Tubes for Transportation of Dangerous Goods; and Commission.

The 20lb. cylinder must be provided with a shut off valve terminating in an LP gas supply cylinder valve outlet specified, as applicable, for connection type QCC1 is the standard for compressed gas cylinder valve outlet and inlet connection ANSI/CSA-V-1.

The cylinder supply system must be arranged for proper vapor withdrawal by making sure the tank is leveled. The cylinder must include a collar to protect the cylinder valve.

Manifold pressure: (operating): 10 in. water column (W.C.), (non-operating): 11.2 in. water column (W.C.).

The LP gas cylinder must be fitted with an Overfill Protection Device (OPD).

### LP GAS HOOK-UP

Make sure the black plastic grommets on the LP cylinder valve are in place, and the hose does not come into contact with the grease tray or grill head.

### LP GAS SUPPLY CYLINDER CONNECTION

Your grill is equipped with gas supply orifices for use only with liquid propane gas. It is also equipped with a high capacity hose/regulator assembly for connection to a standard 20lb. LP cylinder (18-1/4 in. high, 12-1/4 in. diameter).

1. The tank valve should be in the "OFF" position. If not, turn the knob clockwise until it stops.
2. Make sure the tank valve has the proper type 1 connection external male threads per ANSIZ21.81.
3. Make sure all burner valves are in the "OFF" position.
4. Inspect the valve connections, the port and regulator assembly. Look for damage or debris. Remove debris, and inspect hose for damage.
5. When connecting the regulator assembly to the tank valve, use your hand to tighten the nut clockwise until it stops. Use of a wrench may damage the quick coupling nut and result in a hazardous condition.
6. Open the tank valve fully by turning the valve counterclockwise.
7. Before lighting the grill, use a soap and water solution to check all the connections for leaks.
8. If a leak is found, turn the tank valve off and do not use the grill until a local LP gas dealer can make repairs.



#### WARNING

Do not attempt to use damaged or obstructed equipment. See your local LP gas dealer for repair.

### LP GAS SUPPLY CYLINDER DISCONNECTION

1. Turn the burner valves off and make sure the grill is cool.
2. Turn the tank valve off by turning the control knob clockwise until it stops.
3. Detach the regulator assembly from the tank valve by turning the quick coupling nut counterclockwise.
4. Place the dust cap on the liquid propane cylinder valve outlet when the cylinder is not in use. Only install the type of dust cap that is provided with the cylinder valve. The use of other caps or plugs may result in propane leakage.

# PROPANE TANK ASSEMBLY

Fig. 1

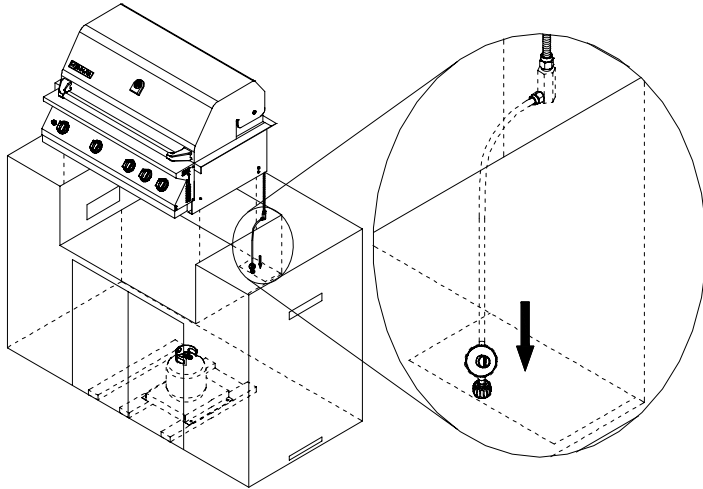

Make sure the LP regulator is located under the island hole as shown in Fig. 1.

Fig. 2

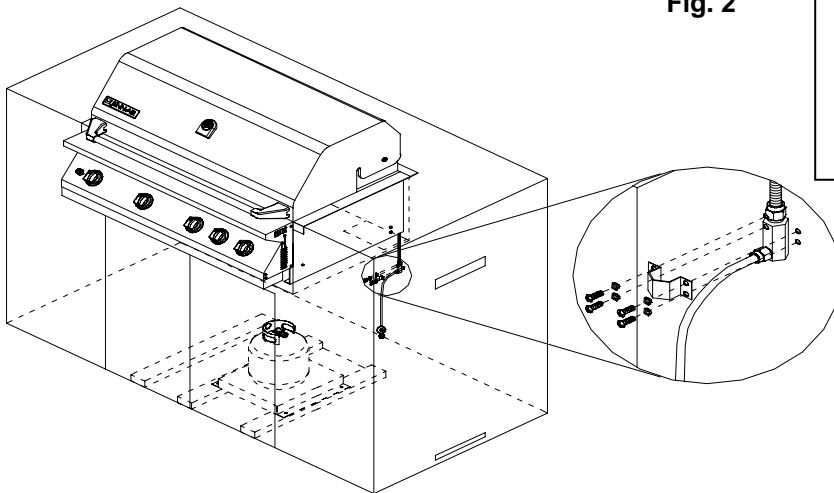

Use the 4 screws and clamp provided to attach the brass connector to the island as shown in Fig. 2. The brass connector is located between the flex tube and gas hose.

Fig. 3

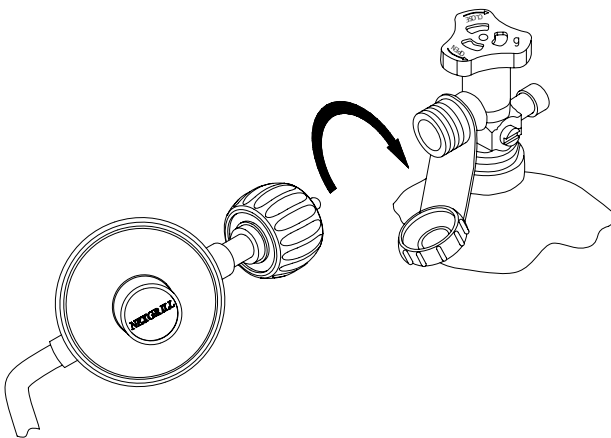

Connect the propane tank by turning the regulator handle clockwise as shown in Fig. 3. Turn off the LP supply at the cylinder when the grill is not in use.

# INSTALLATION OF NATURAL GAS REGULATOR

1. The Natural Gas regulator has been factory installed. Attach the PVC gas hose to the regulator (see drawing below).
2. Adjust the brass elbow so that it is pointing down.
3. Connect the other end of the PVC gas hose to the house gas line using the quick-connect fitting.
4. Do not use the grill until all connections have been checked and do not leak.

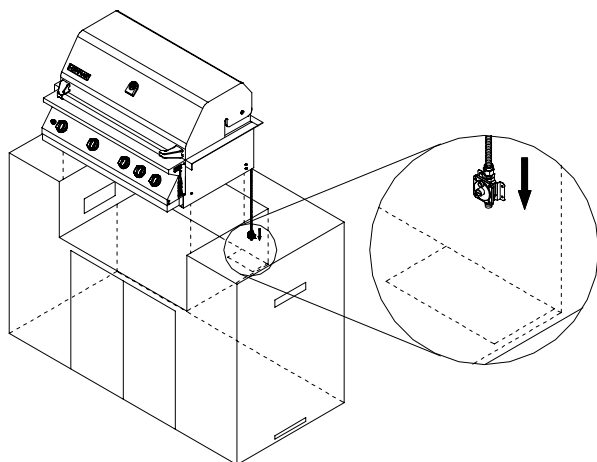

Fig. 1

Make sure the NG regulator is located under island hole as shown in Fig. 1.

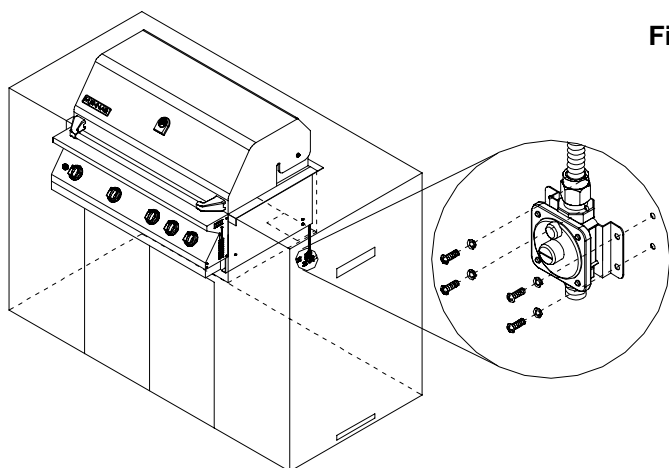

Fig. 2

Use the 4 screws and bracket provided to attach the NG regulator to the island as shown in Fig. 2.

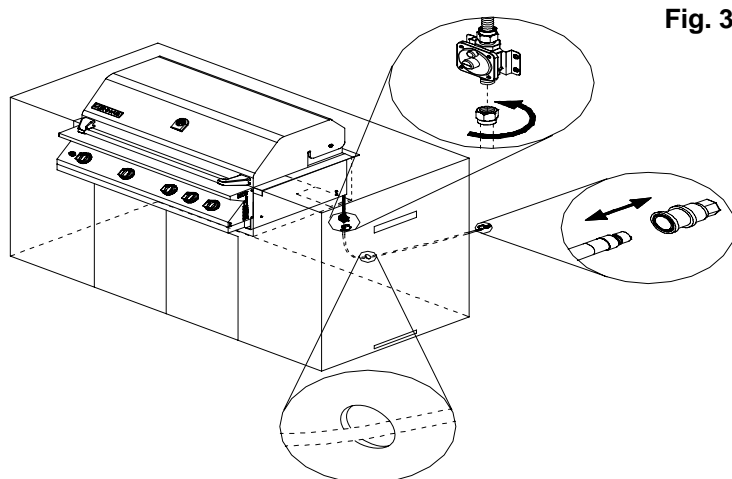

Fig. 3

Insert the 12ft. gas hose through the back of the island and connect to the NG regulator.

## NATURAL GAS HOOK-UP

Only the pressure regulator and hose assembly supplied with the grill should be used. Any replacement pressure regulator and hose assembly must be specified by the grill manufacturer.

The installation of this appliance must conform with the local codes or, in the absence of local codes, to the national fuel gas code, ANSI Z223.1.

Total gas consumption (per hour) of the 750-0593 grill with all burners on the "IGNITE / HI" setting:

Main burners	48,000 BTU/Hr
Rear burner	10,000 BTU/Hr
Total	58,000 BTU/Hr



# LEAK TESTING

## GENERAL

Although all gas connections on the grill are leak tested at the factory prior to shipment, a complete gas tightness check must be performed at the installation site. Periodically check the whole system for leaks following the procedures listed below.

If the smell of gas is detected at anytime you should immediately check the entire system for leaks.

## BEFORE TESTING

Make sure all packing materials have been removed from the grill, including the burner tie-down straps.



### WARNING

Do not use the grill until all connections have been checked and do not leak.

Do not smoke while leak testing.

Never leak test with an open flame.

Make a soap solution of one part liquid detergent and one part water. You will need a spray bottle, brush, or rag to apply the solution to the fittings.

## TO TEST

1. Make sure the control valves are in the "OFF" position, and turn the gas supply "ON".
2. Apply the soap solution to all pipe fittings, from the natural gas regulator and supply valve or from the LP cylinder up to and including the pipe that connects to the burners. Soap bubbles will appear where a leak is present.
3. If a leak is present, immediately turn off the gas supply and tighten the leaky fittings.
4. Turn the gas back "ON" and recheck.
5. Should the gas continue to leak from any of the fittings, turn off the gas supply and contact customer service at 1-800-554-5799.

6. If it is evident there is excessive abrasion or wear, or the hose is cut, it must be replaced prior to the outdoor cooking gas appliance being put into operation.

Only those parts recommended by the manufacturer should be used on the grill. Substitutions will void the warranty.

## GAS FLOW CHECK

Each grill burner is tested and adjusted at the factory prior to shipment. However, variations in the local gas supply may make it necessary to adjust the burners.

Flames should be blue and stable with no yellow tips, excessive noise or lifting.

If any of these conditions exist, first check to see if the burner is blocked by dirt, debris, spider webs, etc. If the burners are clear of foreign objects or debris, please contact customer service at 1-800-554-5799 for further assistance.

**It is handy to keep a spray bottle of soapy water near the shut-off valve of the gas supply line. Spray all the fittings. Bubbles indicate leaks.**

Disconnected LP cylinders must have threaded valve plugs tightly installed, and must not be stored in a building, garage or any other enclosed area.

The gas must be turned off at the supply cylinder when the unit is not in use.

Cylinders must be stored outdoors in a well-ventilated area out of reach of children.



### WARNING

Always check for leaks after every LP tank change.

## INSTALLER FINAL CHECK

- Specified clearance maintained 24 inches from combustible materials/construction.
- All internal packaging has been removed.
- All the burners are factory installed.
- The hose and regulator are properly connected.
- The unit has been tested and is free of leaks.
- The gas supply shut off valve has been located.
- Keep the instruction manual with the grill for future reference.

### Model 750-0593

 **WARNING**

1. The outdoor cooking gas appliance and its individual shutoff valve must be disconnected from the gas supply piping system during any pressure testing of that system at test pressure in excess of 1/2 psi (3.5 kpa).
2. The outdoor cooking gas appliance must be isolated from the gas supply piping system by closing its individual manual shutoff valve during any pressure testing of the gas supply piping system at test pressures equal to or less 1/2 psi (3.5 kpa).

### Model 740-0593

 **WARNING**

1. Do not store spare LP gas cylinders under or near this appliance.
2. Never fill the cylinder beyond 80 percent capacity.
3. If the information above is not followed exactly, a fire causing death or serious injury may occur.

# OPERATING INSTRUCTIONS

## GENERAL USE OF THE GRILL AND ROTISSERIE

Each main burner is rated at 12,000 BTU/Hr. The main grill burners encompass the entire cooking area and are side ported to minimize blockage from falling grease and debris. Above the burners are stainless steel flame tamers. The igniter knobs are located on the lower center portion of the valve panel. Each rotary igniter is labeled on the control panel.

## USING THE GRILL

Grilling requires high heat for searing and proper browning. When grilling, take into consideration the meat involved and desired preparation. Large pieces of meat or poultry may need to be cooked at a lower setting after the initial browning. This method cooks the food thoroughly without burning the outside.

Food cooked for a long time or basted with a sugar-based marinade may need a lower heat setting near the end of its cooking time.

To begin:

1. Make sure the grill has been leak tested and is properly placed.
2. Remove remaining packing materials.
3. Open the lid.
4. Light the grill burners using the instructions on page 19.
5. Turn the control knob(s) to "IGNITE / HI" setting and preheat the grill for 15 minutes. The grill lid should be closed during the pre-heat period.
6. Place the food on the grill and cook to the desired preparation. If necessary, adjust the heat setting. The control knob may be positioned at any setting between "IGNITE / HI" and "LO".



### CAUTION

Do not leave the grill unattended while cooking.

The grill is designed to grill efficiently without the use of lava rocks or briquettes of any kind. Heat is radiated by the stainless steel flame tamers positioned above each burner.

Light the rear burner as described in the lighting instructions on page 19. Once lit, the rotisserie burner will reach cooking temperature in about 1 minute.

The rotisserie motor is capable of turning up to a 12lb. cut of meat or poultry. The motor slides onto the stainless steel motor mount.

The rotisserie motor must be electrically grounded in accordance with local codes or, in the absence of local codes, with the National Electrical Code, ANSI/NFPA 70.



### WARNING

The rotisserie motor is equipped with a plug and should be plugged directly into a properly grounded receptacle.

Do not cut or remove the grounding prong from this plug.

Keep the rotisserie motor cord away from the heated surfaces of the grill. When not in use remove and store the motor in a dry location.

## THE ROTISSERIE SKEWER

The skewer for the rotisserie should be assembled into the motor assembly by placing the pointed end into the motor, and then sliding the grooved bushing into the slot at the opposite side of the grill.

The thumbscrew for the grooved bushing should be inside the grill body.

### LOADING THE ROTISSERIE SKEWER

1. Screw the bushing into the skewer rod at the opposite end from the point.
2. Slide and tighten the counterbalance apparatus onto the skewer rod approximately 2-4 in. from the bushing.
3. Slide the first meat fork onto the skewer rod prongs toward the food.
4. Center the product to be cooked on the skewer, and then push the meat forks firmly together.
5. Tighten the wing nuts.
6. It may also be necessary to wrap the food with butcher's string (never use nylon or plastic string) to secure any loose portions.
7. Once the food is secure, insert the skewer into the motor.

It is normal for the skewer to flex when larger cuts of meat are being cooked. It may also be necessary to remove the cooking grids for larger cuts of meat.

If the meat scrapes on the cooking grids during any part of the rotation, the cooking grids must be removed.

Adjust the counterbalance weight to balance the heavier side of the meat and avoid lopsided rotation of the rotisserie motor.

#### NOTE

After its first use, the stainless steel adjacent to the rotisserie burner will most likely turn dark blue. This is a normal property of the non-rusting, type stainless steel used on the grill.



#### CAUTION

Remove the warming rack when using the rotisserie burner. High heat from the burner may cause the warming rack to bend.

# LIGHTING INSTRUCTIONS

## BEFORE LIGHTING...

Inspect the gas supply piping prior to turning the gas "ON". If there is evidence of cuts, wear, or abrasion, it must be replaced prior to use.



### WARNING

Do not use the grill if gas odor is present. Contact customer service at 1-800-554-5799.

Leak check the piping and regulator connections with a soap and water solution before operating the grill (see instructions on page 15).

Only the pressure regulator supplied with the unit should be used. Never substitute regulators. If a replacement is necessary, contact customer service for proper replacement 1-800-554-5799.

## TO LIGHT THE GRILL BURNER

1. Make sure all knobs are in the "OFF" position, and turn "ON" the gas supply.
2. The igniter is built into the valve. To ignite each burner simply press and turn the control knobs to the "IGNITE / HI" setting, you will hear the valve click as it sends a spark to the pilot flame.
3. If the burner does not light, wait 5 minutes for any excess gas to dissipate and then try again.
4. If the burners still do not light, follow the match lighting instructions on page 21.



### WARNING

When lighting, keep your face and hands as far away from the grill as possible.

## FLAME CHARACTERISTICS

Check for proper burner flame characteristics. Each burner is adjusted prior to shipment. However, variations in the local gas supply may make minor adjustments necessary.

Burner flames should be blue and stable with no yellow tips, excessive noise or lifting.

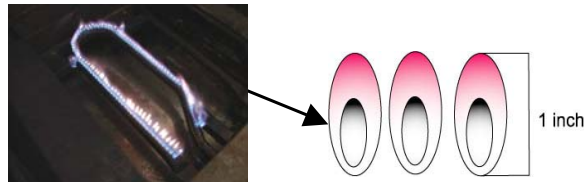

Yellow flames indicate insufficient air. Noisy flames or flames that lift away from the burner indicate too much air (See the "GAS FLOW CHECK" section on page 15).

## TO LIGHT THE ROTISSERIE BURNER

1. Open the lid and press the knob for about 5 seconds without turning it. This will allow time for the gas to flow into the rear burner.
2. Press the knob for 5 seconds, and then turn the knob to the "IGNITE / ON" setting.
3. Press the igniter button to light the rotisserie burner.
4. Once it is lit, release electronic ignition button, and still hold in the Rear Burner knob for another 15 seconds to be sure the burner stays lit.
5. If the burner does not light, turn the control knob to the "OFF" position.
6. If the igniter does not function, follow the instructions on page 21 for match lighting.

Keep a spray bottle of soapy water near the gas supply valve, and check the connections before each use.

# LIGHTING ILLUSTRATIONS

## MAIN BURNER LIGHTING



1. Open the top cover or lid.



2. Push and turn one of the main burner knobs to the "IGNITE/HI" setting.



3. Once the burner ignites, adjust the temperature level as desired.

## ROTISSERIE BURNING LIGHTING



4. Push and turn the Rear Burner knob to the "IGNITE/ON" setting and hold in for 5 seconds while holding, push electronic ignition button, until burner is lit. Once lit, release electronic ignition button, and still hold in the Rear Burner knob for another 15 seconds (if the burner does not ignite follow match lighting instruction on page 21).

## MATCH LIGHTING THE GRILL

If the burner will not light after several attempts using the control knobs, the burner may be lit with a match.

1. If you have already attempted to light the burner with the igniter, allow 5 minutes for any accumulated gas to dissipate.
2. Insert a match into the lighting rod. Ignite the match and insert through the cooking grids to the burner.
3. Press and turn the control knob to the "IGNITE/HI" setting. Continue to press the knob until the burner ignites. The burner should light immediately.
4. If the burner does not ignite within 4 seconds, turn the control knob to the "OFF" position. Wait 5 minutes for the gas to dissipate and try again.

 **WARNING**

When lighting, keep your face and body as far away from the grill as possible.

 **CAUTION**

When using a match to light the grill make sure to use the attached lighting rod.

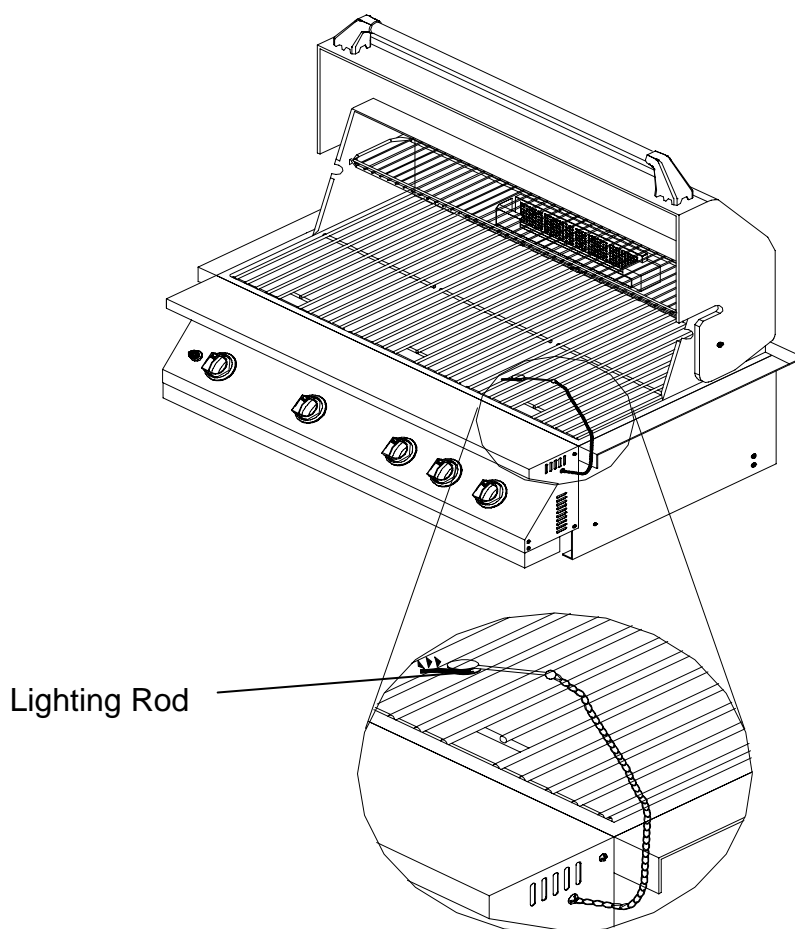

# CARE & MAINTENANCE

## STAINLESS STEEL

Grease specks can gather and bake onto the surfaces of the stainless steel, giving the appearance of rust. For removal, use an abrasive pad with a stainless steel cleaner.

## GRILL RACK

The best time to clean the grill is immediately after cooking is completed, and the flames have been turned off.

Wear a barbeque mitt to protect your hand from heat and steam.

Scrub the hot grill by dipping a bristle barbecue brush in tap water. Cleaning will be more difficult if the grill is allowed to cool.

### CAUTION

Before cleaning, make sure the gas supply and control knobs are in the "OFF" position and the burners have cooled.

## GRILL BURNER CLEANING

1. Turn off the gas supply, and make sure the control knobs are in the "OFF" position.
2. Make certain the grill is cool, and clean the exterior of the burner with a wire brush. Use a metal scraper for stubborn stains.
3. Clear clogged ports with a straightened paper clip. Never use a wooden toothpick. It may break off and clog the port.
4. Check and clean burners/venturi tubes for insects and insect nest. A clogged tube can lead to a fire beneath the grill.
5. If insects or other obstructions are blocking the flow of gas to the burner, call customer service at 1-800-554-5799.

## GRILL BURNERS

Extreme care should be taken when moving a burner. It must be correctly centered on the orifice before any attempt is made to relight the grill. Frequency of cleaning will depend on how often you use the grill.

### WARNING

Failure to properly place the burner over the orifice could cause a fire to occur behind and beneath the valve panel, thereby damaging the grill and making it unsafe to operate.

## GRILL BURNER REMOVAL/INSTALLATION

The grill burners are factory installed.

To remove the main burners for cleaning:

1. Locate the nut at the rear of the burner on the bottom side.
2. Remove the nut and lift the burner out of the fire box.

To reinstall the main burners:

3. Insert the burner over the valve assembly (model 750-0593/740-0593 Item # 19 on pages 24 and 26).
4. Insert the back of the burner into the hole at the rear of the fire box and reinstall the nut.
5. Make sure orifice spud is inside the burner's venturi as shown below.

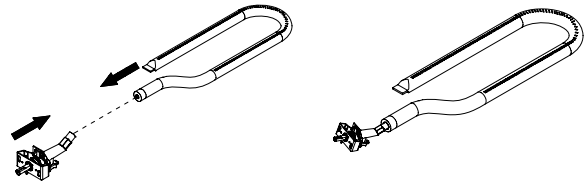

## GREASE TRAY CLEANING

The grease tray should be emptied, wiped down and washed after each use with a mild detergent and warm water solution.

A small amount of sand or cat litter may be placed in the bottom of the grease tray to absorb the grease. Check the grease tray frequently. Do not allow excess grease to accumulate and flow out of the grease tray.

### CHECK YOUR GRILL FOR THE FOLLOWING ITEMS TWICE A YEAR

1. Keep area around the grill free and clear of combustible materials.
2. Do not obstruct the flow of combustible and ventilation air.
3. Visually check the burner flames (see Flame Characteristics on page 19).
4. Clean the grill as described above.
5. Check the grill for spiders and insects (see page 23).



# TROUBLE SHOOTING



## INSECT WARNING

Spiders and insects can nest in the burners of this and other grills, which could disrupt gas flow. This dangerous condition could cause a fire behind and beneath the valve panel, damaging the grill and making it unsafe to operate.

Inspect the grill at least twice a year.

## WHEN TO LOOK FOR SPIDERS

You should inspect the burners twice a year or immediately after any of the following conditions occur:

1. The smell of gas in conjunction with the burner flames appearing yellow.
2. The grill does not reach temperature.
3. The grill heats unevenly.
4. The burners make popping noises.

## BEFORE CALLING FOR SERVICE

If the grill does not function properly, use the checklist below before contacting your dealer for service. You may save yourself the cost of a service call.

### PROBLEMS

Grill will not light when the control knob is rotated.

Burner flame is yellow or orange and the gas odor is present.

Low heat with the knob on "HI".

### WHAT TO DO

- Check to see if house NG valve is open.
  - Check to see if LP tank is empty.
  - Clean wire(s) and/or electrode with rubbing alcohol and a clean swab.
  - Make sure the wire is connected to the electrode assembly.
  - Check to see if other burners operate. If so, check the gas orifice on the malfunctioning burner for an obstruction.
  - Replace the battery.
- 
- Contact customer service at 1-800-554-5799.
- 
- Check to see if the fuel hose is bent or kinked.
  - Make sure the grill area is clear of dust.
  - Check your gas supply and gas pressure.
  - If it is only one burner that appears low, make sure the orifice or burner is clean.

# EXPLODED VIEW MODEL 750-0593

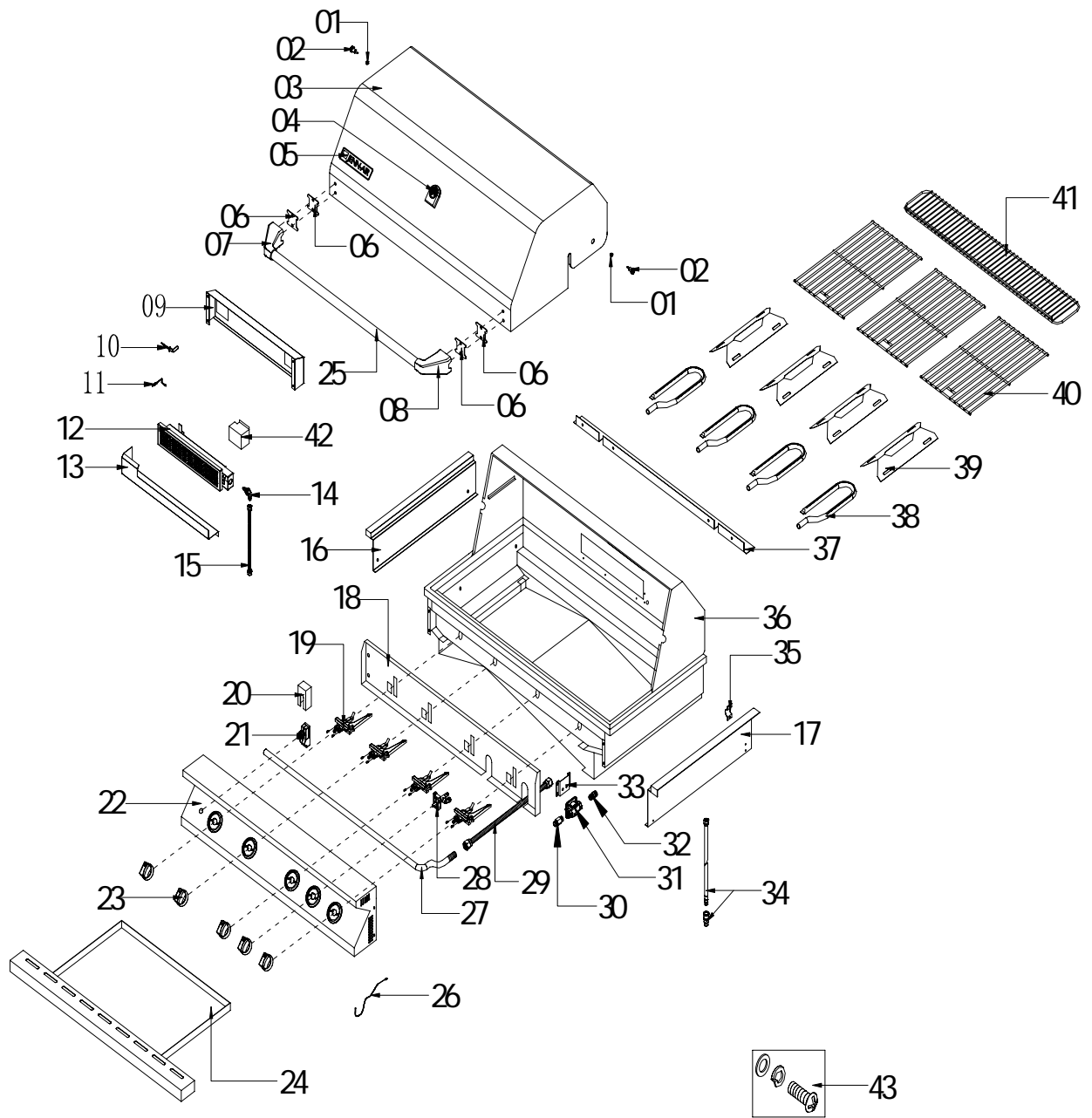

# PARTS LIST

## MODEL 750-0593

REF #	DESCRIPTION	QTY	REF #	DESCRIPTION	QTY
1	Main lid screw cover	2	26	Lighting Rod	1
2	Main lid screw	2	27	Main Manifold	1
3	Main Lid	1	28	Rotisserie Thermocouple Gas Valve	1
4	Temperature Gauge	1	29	Main Burner Flex Gas Line	1
5	Logo	1	30	NG Brass Connector A	1
6	Main Lid Handle Heat Insulating cover	4	31	Regulator, NG	1
7	Main Lid Handle seat, Left	1	32	NG Brass Connector B	1
8	Main Lid Handle seat, Right	1	33	NG Regulator Clamp	1
9	Rear Baffle	1	34	NG Hose W/Quick Connector	1
10	Rotisserie Burner Igniter Wire	1	35	Main Burner Flex Gas Clamp	1
11	Thermocouple	1	36	Main Burner Bowl Assembly	1
12	Rotisserie Burner	1	37	Trim Piece Rear	1
13	Rotisserie Burner Gas Collector	1	38	Main Burner	4
14	Rotisserie orifice w/brass elbow	1	39	Flame Tamer	4
15	Rotisserie Burner Flex Gas Line	1	40	Cooking Grid With Hole	3
16	Flange, Left	1	41	Warming Rack	1
17	Flange, Right	1	42	Thermocouple bracket	1
18	Front Baffle	1	43	Hardware	1
19	Main Gas Valve	4			
20	Pulse Igniter Module cover	1			
21	pulse Igniter Module	1			
22	Main Control Panel	1			
23	Control Knob	5			
24	Grease Tray	1		A01 112007 /A00 Cathy_Zhang 112007	
25	Main lid handle tube	1		Felicity_Yang112007	

# EXPLODED VIEW MODEL 740-0593

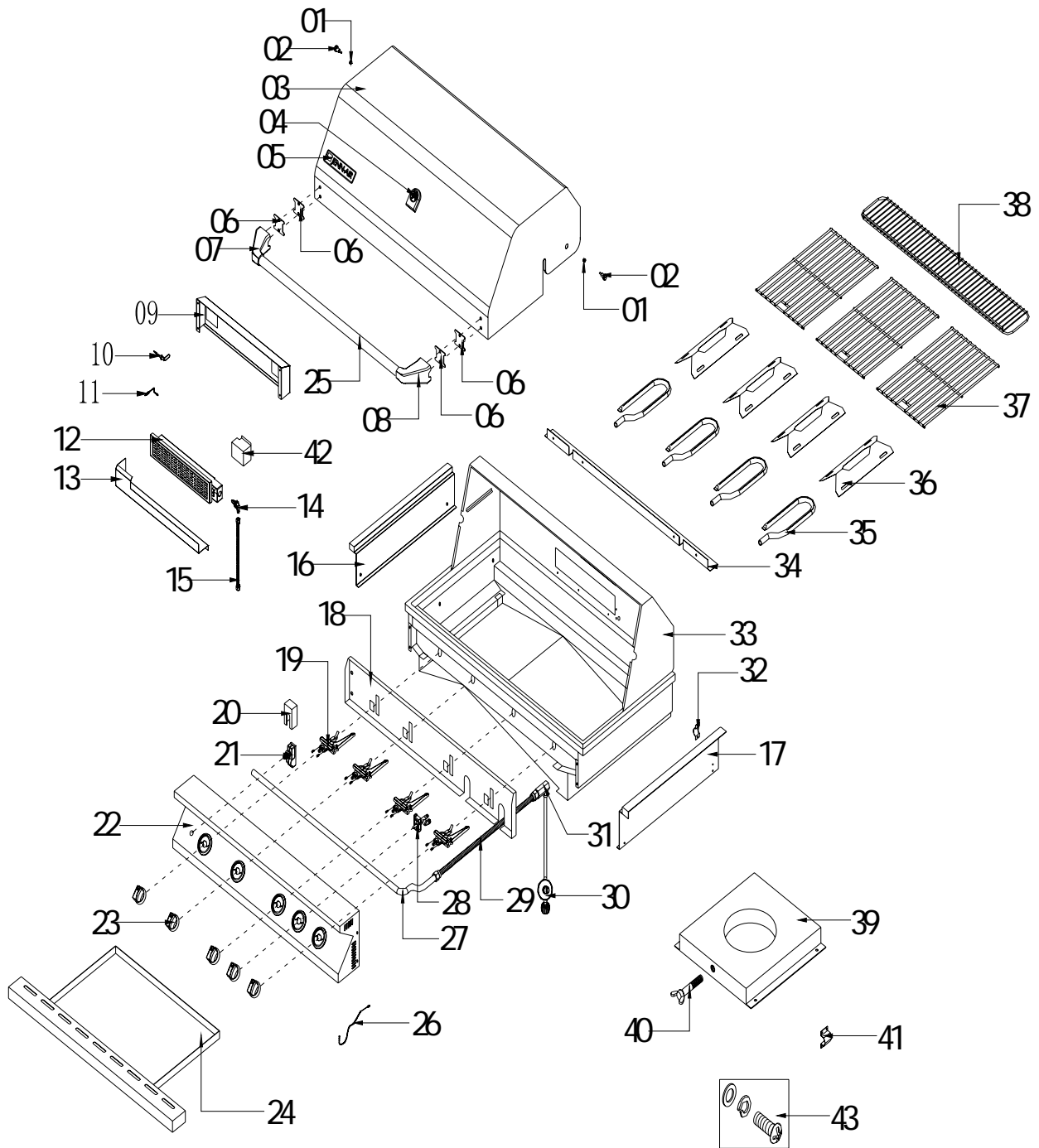

# PARTS LIST

## MODEL 740-0593

REF #	DESCRIPTION	QTY	REF #	DESCRIPTION	QTY
1	Main lid screw cover	2	26	Lighting Rod	1
2	Main lid screw	2	27	Main Manifold	1
3	Main Lid	1	28	Rotisserie Thermocouple Gas Valve	1
4	Temperature Gauge	1	29	Main Burner Flex Gas Line	1
5	Logo	1	30	Regulator, LP	1
6	Main Lid Handle Heat Insulating cover	4	31	90 Degree Brass Adaptor	1
7	Main Lid Handle, Left	1	32	Main Burner Flex Gas Clamp	1
8	Main Lid Handle, Right	1	33	Main Burner Bowl Assembly	1
9	Rear Baffle	1	34	Trim Piece Rear	1
10	Rotisserie Burner Igniter Wire	1	35	Main Burner	4
11	Thermocouple	1	36	Flame Tamer	4
12	Rotisserie Burner	1	37	Cooking Grid With Hole	3
13	Rotisserie Burner Gas Collector	1	38	Warming Rack	1
14	Rotisserie orifice w/brass elbow	1	39	Tank tray	1
15	Rotisserie Burner Flex Gas Line	1	40	Tank Bolt	1
16	Flange, Left	1	41	90 Degree Brass Clamp	1
17	Flange, Right	1	42	Thermocouple bracket	1
18	Front Baffle	1	43	Hardware	1
19	Main Gas Valve ( Cast Brass)	4			
20	pulse Igniter Module cover	1			
21	pulse Igniter Module	1			
22	Main Control Panel	1			
23	Control Knob	5			
24	Grease Tray	1		A01 112007 /A00 Cathy_Zhang 102907	
25	Main lid handle tube	1		Felicity_Yang112007	

## GRILLING HINTS

This Jenn-Air grill has an infrared side burner – commonly referred to as a “searing” burner. This type of burner produces extreme heat that can be used to “sear” the outside of food thus locking the juices inside. This process is used at many upscale restaurants to improve the flavor of the food. To properly use, cook each side of the meat for 1-2 minutes on the searing side burner and then move the meat to the main cooking surface to finish cooking the inside to your choice.

The preparation of meat, whether rare, medium, or well done, is affected to a large degree by the thickness of the cut.

The cooking time is affected by the type of meat, the size and shape of the cut, the temperature of the meat when cooking begins, and the degree of preparation desired.

It is recommended that meat be defrosted overnight in the refrigerator as opposed to a microwave. This generally yields a juicier cut of meat.

Use a spatula instead of tongs or a fork to turn the meat. A spatula will not puncture the meat and let the juices run out.

To get the juiciest meat, add seasoning or salt after cooking is finished and turn the meat only once during cooking. Juices are lost when the meat is turned several times. Turn the meat just after the juices begin to bubble to the surface.

Trim excess fat from the meat before cooking. To prevent steaks or chops from curling during cooking, slit the fat around the edges at 2 inch intervals.

 **WARNING**  
Do not leave the grill unattended while cooking.

## GRILL COOKING CHART

FOOD	WEIGHT OR THICKNESS	FLAME SIZE	APPROXIMATE TIME	SPECIAL INSTRUCTIONS AND TIPS
VEGETABLES				Slice. Dot with butter or margarine. Wrap in heavy-duty foil. Grill, turning occasionally.
Fresh Beets Carrots Turnips		Medium	12 to 20 minutes	Grill, turning once. Brush occasionally with melted butter or margarine.
Onion	1/2 inch slices	Medium	8 to 20 minutes	Season with Italian dressing, butter, or margarine.
Potatoes Sweet	Whole	Medium	40 to 60 minutes	Wrap individually in heavy-duty foil. Grill, rotating occasionally.
White	6 to 8 ounces	High	45 to 60 minutes	
Frozen Asparagus Peas Green beans Sprouts Broccoli Brussels		Medium	15 to 30 minutes	Dot with butter or margarine. Wrap in heavy-duty foil. Grill, turning occasionally.

French fries		Medium	15 to 30 minutes	Place in aluminum foil pan. Grill, stirring occasionally.
<b>FOOD</b>	<b>WEIGHT OR THICKNESS</b>	<b>FLAME SIZE</b>	<b>APPROXIMATE TIME</b>	<b>SPECIAL INSTRUCTIONS AND TIPS</b>
MEATS BEEF				
Hamburgers	1/2 to 3/4 inch	Medium	10 to 18 minutes	Grill, turning once when juices rise to the surface. Do not leave hamburgers unattended. A flare-up could occur quickly.
Tenderloin, Porterhouse, Rib eye		High	8 to 15 minutes	
Rare	1 inch	High	8 to 14 minutes	Remove excess fat from edges. Slash remaining fat at 2-inch intervals. Grill, turning once.
Medium	1-1/2 inch 1 inch 1-1/2 inch	High Medium to High	11 to 18 minutes 12 to 22 minutes 16 to 27 minutes	
Well-done	1 inch 1-1/2 inches	Medium Medium	18 to 30 minutes 16 to 35 minutes	
Lamb Chops & Steaks Rare	1 inch	High	10 to 15 minutes	
	1-1/2 inch	High	14 to 18 minutes	Remove excess fat from edges. Slash remaining fat at 2 inch intervals. Grill, turning once.
Medium	1 inch 1-1/2 inch	Medium to High	13 to 20 minutes 18 to 25 minutes	
Well-done	1 inch	Medium	17 to 30 minutes	
Pork Chops	1 inch	Medium	20 to 30 minutes	Remove excess fat from edges. Slash remaining fat at 2 inch intervals. Grill, turning once. Cook well done.
Well-done	1-1/2 inches	Medium	30 to 40 minutes	
Ribs Pork		Medium	30 to 40 minutes	Grill, turning occasionally. During last few minutes, brush with barbecue sauce, turning several times.
Ham steaks (precooked)	1/2 inch slices	High	4 to 8 minutes	Remove excess fat from edges. Slash remaining fat at 2 inch intervals. Grill, turning once.
Hot dogs		Medium	5 to 10 minutes	Slit skin. Grill, turning once.

POULTRY Broiler/fryer	2 to 3 pounds	Low	1 to 1-1/2 hours	Place skin side up. Grill. Turn and brush frequently with melted butter, margarine, oil, or marinade.
<b>FOOD</b>	<b>WEIGHT OR THICKNESS</b>	<b>FLAME SIZE</b>	<b>APPROXIMATE TIME</b>	<b>SPECIAL INSTRUCTIONS AND TIPS</b>
Breasts well-done		Medium	30 to 45 minutes	Marinate with Italian dressing
FISH AND SEAFOOD				
Steaks Halibut Salmon Swordfish	3/4 to 1 inch	Medium to High	8 to 15 minutes	Grill, turning once. Brush with melted butter, margarine or oil to keep moist.
Whole Catfish	4 to 8 ounces	Medium to	12 to 20 minutes	Grill turning once. Brush with melted butter, margarine or oil.
Rainbow trout		High		Brush with melted butter and lemon juice.



# GRILL RECIPES

## BBQ SALMON

2 large salmon steaks  
2 tbs. oil  
Salt & pepper  
2 oz. thin bacon slices  
2 tbs. butter  
1 tbs. lemon juice  
Sprig of parsley  
Lemon wedges

\*You can substitute catfish, halibut or cod for salmon.

Preheat the BBQ

Brush the steaks with oil and season with salt and pepper. Place on BBQ grill and cook for 10 minutes, turning steaks over halfway through cooking time.

Meanwhile fry the bacon in a pan on the side burner. Drain on paper towels. Melt the butter in a small saucepan taking care not to discolor it. Arrange the fish and bacon on serving plates. Pour the butter over and sprinkle with lemon juice. Garnish with parsley sprigs and lemon wedges. Serve with boiled potatoes in butter and sprinkled with parsley.

## BAKED CHILI CORN

6 medium ears corn, husked  
3 tbs. butter or margarine, melted  
Dash ground cumin  
Dash ground coriander

About 1/2 hour before cooking, turn the grill on for butter. Place each ear on a heavy-duty foil. In a bowl, combine remaining ingredients. Mix well. Brush 1-1/2 tsp. butter mixture over each ear. Close foil and fold up ends to seal. Place on grill. Cook, turning packets occasionally 10 to 12 minutes or until cooked through.

## TANGY SEAFOOD KABOBS

1 lb. large shrimp, shelled & deveined  
3/4 lbs. Sea scallops  
2/3 c. chili sauce  
1/4 c. cider vinegar  
3 tbs. Chopped parsley  
1 tbs. Vegetable oil  
1 tbs. Worcestershire sauce  
1/2 tsp. Prepared horseradish  
1 clove garlic, minced  
1 20 oz. Can pineapple chunks in juice drained.

In medium bowl, combine shrimp and scallops. In small bowl, combine chili sauce and next six ingredients. Pour over seafood. Toss to coat. Cover, refrigerate 2 hours.

Half-hour before cooking, turn the burner to the grill on high. Drain seafood-reserving marinade. On each of twelve 10 in. skewers, thread 2 shrimp and 2 scallops, alternating with pineapple chunks. Place skewers on grill. Cook 7-10 minutes, basting and turning often.

## PORK CHOPS

4 pork chops  
Marinade  
1 large onion  
2 tbs. lemon juice or vinegar  
2 tbs. oil  
1/2 tsp. freshly ground black pepper  
1 tsp. sugar  
1/2 tsp. paprika  
1 clove garlic  
Peel, grate onion, and add rest of the ingredients except the pork chops. Mix well. Pour over chops and marinate one hour in a cool place. Turn the BBQ grill on high. Heat 10 minutes. BBQ the chops brushing with the marinade occasionally. Serve with mixed salad, dressed with vinaigrette flavored with fresh dill.

## BARBECUED POTATOES and CHEESE

1 -1/2 cups shredded cheddar cheese  
1 can (10-3/4 oz.) condensed cream of mushroom soup  
1/3 cup milk  
2 tbs. barbecue sauce  
1/4 tsp. oregano  
1/4 tsp. salt  
1/8 tsp. pepper  
4 cups thinly sliced potatoes (4 medium-sized potatoes)

Preheat grill. Combine cheese, condensed soup, milk, BBQ sauce, oregano, salt and pepper in a large mixing bowl. Stir in potatoes until well coated. Turn into well-buttered 1-1/2 quart rectangular baking dish. Cover dish with aluminum foil. Bake covered 25 minutes on medium with the lid of your BBQ grill closed. Remove foil and continue baking 15 minutes longer or until potatoes are tender. Let stand 5 minutes before serving.

## BARBECUED LONDON BROIL

4 to 6 servings  
3/4 c. Italian dressing

1 tsp. Worcestershire sauce  
1 tsp. Dry mustard  
1/4 tsp. Thyme, crushed  
1 medium onion, sliced  
1 pound flank steak, scoured  
2 tbs. Butter, melted

Combine first 4 ingredients, add onion and marinade flank steak with it. Refrigerate at least 4 hours or overnight. Remove steak and grill on preheated BBQ grill. Grill 5 to 7 minutes on each side basting frequently with the marinade. In the meantime sauté onions from the marinade in butter in a skillet on grill side burner for 3 minutes. To serve, slice steak diagonally into thin slices, sprinkle onions over top. Garnish with vegetable kabobs.

## VEGETABLE KABOBS

3 medium-size zucchini  
12 cherry tomatoes  
12 fresh mushrooms  
Grated parmesan cheese

Parboil whole zucchini 5 minutes on grill side burner or until just tender. Drain and cut into 1/2 inch slices. Thread zucchini, tomatoes and mushrooms alternately on each of six skewers. Brush with marinade made of Italian dressing, Worcestershire sauce, mustard and thyme. Grill 5 to 7 minutes turning and basting occasionally. Sprinkle liberally with Parmesan cheese.

## FAJITAS

1-1/2 lb. flank steak or boned chicken breasts  
2 tbs. oil  
1/2 cup lime juice  
1/2 tsp. salt  
1/2 tsp. celery salt  
1/4 tsp. garlic powder  
1/2 tsp. pepper  
1/4 tsp. oregano  
1/4 tsp. cumin  
Flour tortillas  
Lemon

Pound flank steak to 1/4 inch thickness or flatten chicken breasts. Mix oil, lime juice and seasonings in a zip lock bag. Add meat and shake bag to coat the meat. Refrigerate overnight or at least 6 to 8 hours. Wrap tortillas in foil. Remove meat from marinade. Cook on a pre-heated gas grill for 5 to 8 minutes on each side. While meat is cooking,

heat tortillas on grill. Slice meat across grain in thin slices. Place on hot platter. Squeeze lemon juice over. Wrap meat and any of the following toppings in tortillas: chopped tomatoes, guacamole, sour cream, and taco sauce.

### **BEEF AND LAMB KABOBS**

Serve 4

1/2 lb. boneless sirloin or beef cut into 1 in. cubes  
1/2 lb. boneless loin of lamb cut into 1 in. cubes  
2/3 c. water, divided  
1/4 c. chopped onion  
2 tbs. soy sauce  
1/4 c. vegetable oil, divided  
1 tbs. dark brown sugar  
1 tbs. fresh lemon juice  
2 cloves garlic, minced  
1/4 tsp. ground cumin  
1/4 tsp. ground coriander  
1/4 tsp. ground turmeric  
1/8 tsp. ground red pepper  
1/8 tsp. ground ginger  
1 red pepper cut into chunks  
1 large banana, cut into chunks  
8 small mushrooms  
1/3 c. smooth peanut butter

In blender, process 1/3 c. water, onion, soy sauce, 2 tsp. oil and the next 8 ingredients until smooth. Pour over meat cubes and marinate about 4 hours, turning occasionally. Drain and reserve marinade. Onto four 12 in. skewers alternately thread meat, pepper, banana and mushrooms. Preheat grill. Brush the kabobs with oil. Grill 7-8 minutes each side.

Bring marinade to boil on the side burner in a saucepan. Add remaining 1/3 c. water and peanut butter. Stir to blend. Heat through. If sauce gets too thick, add 1 tbs. water. Serve sauce with kabobs.

### **EGGPLANT CAVIAR**

1 large eggplant  
2 tbs. olive oil  
2 tbs. wine vinegar  
2 tbs. finely chopped onion  
1/2 clove garlic, minced  
1 medium tomato, chopped salt and pepper

Roast eggplant on gas grill over medium flame, turning occasionally until thoroughly cooked. This may take 30 minutes. Remove from grill and cool for handling. Strip off the skin and chop eggplant finely. Add all the seasonings. Chill thoroughly and serve on toast.

### **CHICKEN TANDOORI STYLE**

8 large chicken thighs or drumsticks  
1 c. plain nonfat yogurt  
1/2 c. lemon juice  
2 tsp. salt  
1/2 tsp. cayenne  
1/2 tsp. black pepper  
1/2 tsp. crushed garlic  
1/2 tsp. grated ginger  
1 tbs. corn oil

Combine all the ingredients in a large mixing bowl and marinate the chicken for 8 hours in the refrigerator. Drain the chicken and spread on the spit running the rod on the fleshier side of the bone.

Bake using the rotisserie. Cook on medium high heat for 40 minutes basting occasionally with the remainder of the marinade mixture. Serve with sliced onions and lemon wedges.

### **SPARE RIBS**

Marinade:  
1 c. soy sauce  
1/2 c. honey  
1/2 c. vinegar  
1/2 c. dry sherry  
2 tsp. chopped garlic  
2 tsp. sugar  
1 c. water  
1 chicken bouillon cube  
1 can beer for basting sauce

Marinate ribs for 3 hours. Use marinade for basting by adding beer to it. Place pan under the ribs and baste frequently. To cook ribs select lean, meaty ribs and accordion pleat them with your spit. Slide four-prong meat hook down the length of spit and tighten. At the beginning of the rack and to its center, penetrate the second rib with the pointed end of the spit and push it between the meat. Skip a couple and continue the process until the entire rack is accordion pleated. Fasten the second meat hook into the rack. Turn rotisserie burner on high. Bake using the rotisserie for 50 minutes or until done.

### **PORK ROAST**

Apple cider vinegar basting sauce:  
1 c. apple cider vinegar  
6 oz. water  
1/2 stick butter  
Salt, pepper, parsley and garlic seasoning

2 oz. lemon juice  
10 lbs. pork roast

Time: 1-1/2 hours to 2 hours  
Bring pork to room temperature before placing it on the rotisserie spit rod. Place on the rod and test for balance. Light rotisseries burner. Turn control knob to high. Use the above basting sauce for rotisserie baking

### **TURKEY**

12 lb. turkey  
Beer basting sauce:  
1 can beer  
12 oz. water  
1 stick butter  
1 tsp. salt  
1 tsp. pepper  
1/2 tsp. garlic flakes  
1 tsp. parsley

Thaw the bird completely. Wash inside out. Securely tie the legs and wings before placing the turkey on the rotisserie spit rod. Light rotisseries burner. Turn to high. Combine all the ingredients for basting sauce in a shallow pan. Place it under the turkey 15 to 20 minutes. Cook for approximately 3 hours. The basting sauce combined with turkey drippings makes delicious gravy.

Nexgrill Industries warrants to the original consumer-purchaser only that this product (Model #750-6593/7-40-6593) shall be free from defects in workmanship and materials after correct assembly and under normal and reasonable home use for the periods indicated below beginning on the date of purchase. The manufacturer reserves the right to require that defective parts be returned, postage and or freight pre-paid, by the consumer, for review and examination.

- Burners: **LIMITED Lifetime** warranty against perforation.
- Stainless Steel Parts: **LIMITED Lifetime** warranty against perforation.  
\*Does not cover cosmetic issues like surface corrosion, scratches and rust.
- All other parts: **LIMITED 1 year** warranty  
\*Does not cover chipping, scratching, cracking surface corrosion, scratches or rust.

Upon consumer supplying proof of purchase as provided herein, Manufacturer will repair or replace the parts which are proven defective during the applicable warranty period. Parts required to complete such repair or replacement shall be free of charge to you except for shipping costs, as long as the purchaser is within the warranty period from the original date of purchase. The original consumer-purchaser will be responsible for all shipping charges of parts replaced under the terms of this limited warranty. This limited warranty is applicable in the United States only, is only available to the original owner of the product and is not transferable. Manufacturer requires reasonable proof of your date of purchase. Therefore, you should retain your sales receipt and/or invoice. Defective or missing parts subject to this limited warranty will not be replaced without registration or proof of purchase. This limited warranty applies to the functionality of the product ONLY and does not cover cosmetic issues such as scratches, dents, corrosion or discoloring by heat, abrasive and chemical cleaners or any tools used in the assembly or installation of the appliance, surface rust, or the discoloration of stainless steel surfaces. Surface rust, corrosion, or powder paint chipping on metal parts that does not affect the structural integrity of the product is not considered a defect in workmanship or material and is not covered by this warranty. This limited warranty will not reimburse you for the cost of any inconvenience, food, personal injury or property damage. If an original replacement part is not available, a comparable replacement part will be sent. You will be responsible for all shipping charges of parts replaced under the terms of this limited warranty.

**ITEMS MANUFACTURER WILL NOT PAY FOR:**

1. Service calls to your home.
2. Repairs when your product is used for other than normal, single-family household or residential use.
3. Damage resulting from accident, alteration, misuse, abuse, fire, flood, acts of God, improper installation, and installation not in accordance with electrical or plumbing codes or use of products not approved by the manufacturer.
4. Any food loss due to product failures.
5. Replacement parts or repair labor costs for units operated outside the United States or Canada.
6. Pickup and delivery of your product.
7. Repairs to parts or systems resulting from unauthorized modifications made to the product.
8. The removal and/or reinstallation of your product.
9. Shipping cost, standard or expedited, for warranty/non warranty and replacement parts.

**DISCLAIMER OF IMPLIED WARRANTIES; LIMITATION OF REMEDIES**

Repair or replacement of defective parts is your exclusive remedy under the terms of this limited warranty. Manufacturer will not be responsible for any consequential or incidental damages arising from the breach of either this limited warranty or any applicable implied warranty, or for failure or damage resulting from acts of God, improper care and maintenance, grease fire, accident, alteration, replacement of parts by anyone other than Manufacturer, misuse, transportation, commercial use, abuse, hostile environments (inclement weather, acts of nature, animal tampering), improper installation or installation not in accordance with local codes or printed manufacturer instructions.

THIS LIMITED WARRANTY IS THE SOLE EXPRESS WARRANTY GIVEN BY THE MANUFACTURER. NO PRODUCT PERFORMANCE SPECIFICATION OR DESCRIPTION WHEREVER APPEARING IS WARRANTED BY MANUFACTURER EXCEPT TO THE EXTENT SET FORTH IN THIS LIMITED WARRANTY. ANY IMPLIED WARRANTY PROTECTION ARISING UNDER THE LAWS OF ANY STATE, INCLUDING IMPLIED WARRANTY OF MERCHANTABILITY OR FITNESS FOR A PARTICULAR PURPOSE OR USE, IS HEREBY LIMITED IN DURATION TO THE DURATION OF THIS LIMITED WARRANTY.

Neither dealers nor the retail establishment selling this product has any authority to make any additional warranties or to promise remedies in addition to or inconsistent with those stated above. Manufacturer's maximum liability, in any event, shall not exceed the documented purchase price of the product paid by the original consumer. This warranty only applies to units purchased from an authorized retailer and or re-seller. NOTE: Some states do not allow an exclusion or limitation of incidental or consequential damages, so some of the above limitations or exclusions may not apply to you; this limited warranty gives you specific legal rights as set for herein. You may also have other rights which vary from state to state.

If you wish to obtain performance of any obligation under this limited warranty, you should write to:  
Nexgrill Industries Customer Relations  
280 Machin Court  
City of Industry, CA 91789

All consumer returns, parts orders, questions and troubleshooting can be acquired by calling 1-800-554-5799, Monday – Friday, 7 a.m. - 6 p.m. PST. During the months between May – August, we offer additional assistance on Saturday from 8 a.m. - 12 p.m. PST.