

This Owner's Manual is provided and hosted by [Appliance Factory Parts](#).



CUISINART CPM-900 Owner's Manual

[Shop genuine replacement parts for CUISINART
CPM-900](#)

1. **Measuring Cup**
½-cup capacity
2. **Bowl Cap**
3. **Serving Bowl**
Plastic serving bowl with built-in ventilation, bowl cover and handles
4. **Removable Popping Plate Assembly**
Dishwasher-safe popping plate
5. **Handles with Safety Interlocks for Plate**
Cool-touch handles for popping plate
6. **Plate Locking Levers**
Assures popping plate is secured to the base
7. **Rotation Shaft**
Turns stirring rod
8. **Handles**
Side handles in base
9. **Base**
Elegant stainless steel base
10. **On/Off Switch**
Power activation

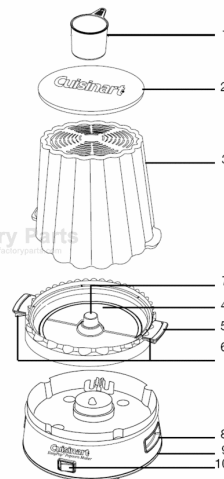

[Find Your CUISINART Small Appliance Parts - Select From 213 Models](#)

----- Manual continues below -----

Cuisinart®

INSTRUCTION AND
RECIPE BOOKLET



EasyPop™ Popcorn Maker

CPM-900 Series

For your safety and continued enjoyment of this product, always read the instruction book carefully before using.

IMPORTANT SAFEGUARDS

When using an electrical appliance, basic safety precautions should always be followed, including the following:

1. **Read all instructions.**
2. Do not touch hot surface. Use handle or knobs.
3. To protect against electric shock, do not immerse cord, plugs, or this appliance in water or other liquid.
4. Close supervision is necessary when any appliance is used by or near children.
5. Unplug from outlet when not in use and before cleaning. Allow to cool before putting on or taking off parts, and before cleaning the appliance.
6. Do not operate any appliance with a damaged cord or plug or after the appliance malfunctions, or has been damaged in any manner. Return appliance to the nearest authorized service facility for examination, repair or adjustment.
7. The use of accessory attachments not recommended by the appliance manufacturer may cause injuries.
8. Do not use outdoors.
9. Do not let cord hang over edge of table or counter, or touch hot surface.
10. Do not place on or near a hot gas or electric burner, or in a heated oven.
11. Extreme caution must be used when moving an appliance containing hot oil or other hot liquids.
12. Always attach plug to appliance first, then plug cord in the wall outlet. To disconnect, turn any control to off, then remove plug from wall outlet.
13. Do not use appliance for other than intended household use.
14. Never steam food in the popping plate.
15. A popper that is plugged into an outlet should not be left unattended.
16. **CAUTION** – a burn can result from misuse of this product. Read instruction manual for proper operating procedure.

17. Extreme caution must be used when unloading popcorn. Always turn the unit over a countertop so that residual hot oil or water running out will not cause burns.

SAVE THESE INSTRUCTIONS FOR HOUSEHOLD USE ONLY

SPECIAL CORDSET INSTRUCTIONS

NOTICE

This appliance has a polarized plug (one blade is wider than the other). To reduce the risk of electric shock, this plug will fit in a polarized outlet only one way. If the plug does not fit fully in the outlet, reverse the plug. If it still does not fit, contact a qualified electrician. Do not modify the plug in any way.

CONTENTS

Important Safeguards	2
Introduction	2
Parts and Features	3
Before the First Use	3
Cord Instructions	3
Operating Instructions	4
Cleaning and Maintenance	4
Tips and Hints	5
Seasoning Suggestions	5
Recipes	6
Warranty	10

INTRODUCTION

Get ready to enjoy warm, fresh popcorn whenever you want it. Your new Cuisinart® EasyPop™ Popcorn Maker is simply sensational. It can pop up to 10 cups in less than five minutes, and you decide what and how much oil and flavoring to add. And it's easy. Just turn it on, let it pop, and then flip the bowl to serve!

PARTS AND FEATURES

- 1. Measuring Cup**
½-cup capacity
- 2. Bowl Cap**
- 3. Serving Bowl**
Plastic serving bowl with built-in ventilation, bowl cover and handles
- 4. Removable Popping Plate Assembly**
Dishwasher-safe popping plate
- 5. Handles with Safety Interlocks for Plate**
Cool-touch handles for popping plate
- 6. Plate Locking Levers**
Assures popping plate is secured to the base
- 7. Rotation Shaft**
Turns stirring rod
- 8. Handles**
Side handles in base
- 9. Base**
Elegant stainless steel base
- 10. On/Off Switch**
Power activation

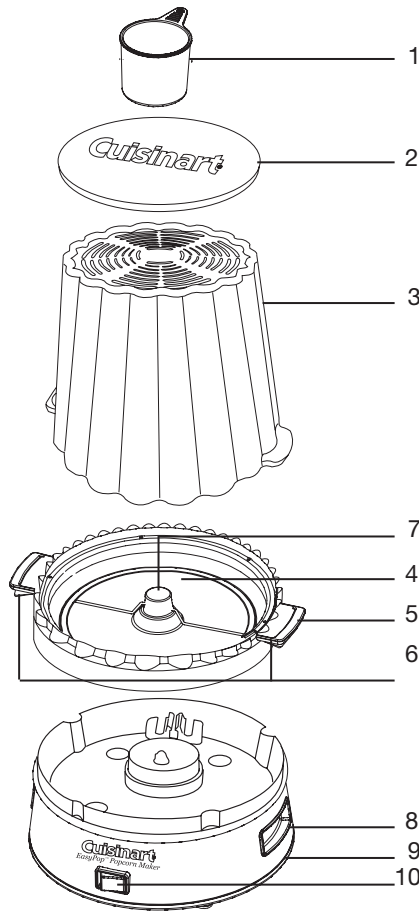

BEFORE THE FIRST USE

Remove all packaging and any promotional labels or stickers from your popcorn maker. Be sure that all parts (listed above, Parts and Features) of your new popcorn maker have been included before discarding any packaging materials. You may want to keep the box and packing materials for use at a later date. Keep all plastic bags away from children.

Before using your Cuisinart® EasyPop™ Popcorn Maker for the first time, remove all protective paper and wrapping. Wipe housing and internal chamber with a damp cloth to remove any dust from the warehouse or shipping.

CORD INSTRUCTIONS

1. A short power supply cord is provided to reduce the risk of becoming entangled in or tripping over a long cord.
2. Extension cords may be used if care is exercised in their use.
3. If an extension cord is used,
 - A) The marked electrical rating of the extension cord should be at least as great as the electrical rating of the appliance.
 - B) The longer cord should be arranged so that it will not drape over the countertop or tabletop where it can be pulled on by children or tripped over unintentionally.

OPERATING INSTRUCTIONS

1. Place the base of the appliance on a clean, flat surface. **Caution: Do not let water or any other liquid drip into the base or on the heat shield.**
2. Popping plate must lock securely to base before unit will operate. Grip the locking levers up toward the handles of popping plate, which will open the lock. Place the plate on the base (handles of popping plate should be centered just above the side handles on base, see Fig.1). Once locking levers are released, the popping plate should be locked to the base.

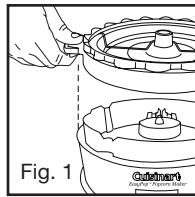

NOTE: The unit will not operate if popping plate is not positioned correctly. Rotate plate very slightly back and forth until you feel the plate fall into place.

3. Add approximately 2 teaspoons of cooking oil to popping plate (see Tips and Hints, next page, for recommended measurements). We recommend using vegetable or canola oil, but any type is suitable except olive oil.
4. Add kernels to popping plate. **We recommend 1/3 cup of kernels, especially if using premium popcorn.** The measuring cup provided is 1/2-cup capacity, and also clearly marked for 1/3 cup. See Tips and Hints, next page.
5. Place the inverted bowl on top of the popping plate.
6. Plug the power cord into a standard electrical outlet.
7. Turn the power switch to ON.
8. The stirring rod will rotate and cooking will begin.
9. When the popcorn has finished popping, turn the unit off. Place cap on bowl (before seasoning). Grasp the locking lever against handles of

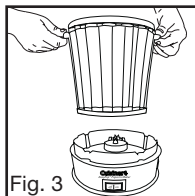
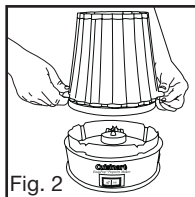

popping plate, along with bowl handles together.

Gently lift plate and bowl from the base (see fig.2). Turn over and place the bottom of bowl on a flat surface (see fig.3).

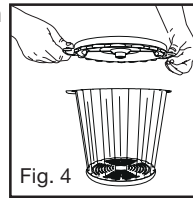

10. To avoid any burning of popcorn, flip the bowl as soon as popping is complete.
11. Lift the popping plate off the bowl by its handles, and immediately return the plate to the base to cool (see fig.4).

CAUTION: After popping, the plate is EXTREMELY HOT. Do not put fingers near the plate. After turning the bowl over to serve, simply return popping plate directly to the base.

A slight odor or smoke may be evident as materials used in manufacturing are burned off internal parts. This is normal.

12. Rotation shaft continues turning until unit is switched OFF manually.

CLEANING AND MAINTENANCE

Clean your popcorn maker after every use.

Never immerse the base of the unit in water or let water drip inside. Do not use benzene, scrubbing brushes or chemical cleaners, as these will damage the unit. Use only a damp cloth to clean exterior of the base.

Serving bowl – The serving bowl is fully immersible and dishwasher-safe. Do not clean plastic serving bowl with the scourer side of a sponge.

Popping plate – Popping plate is fully immersible and dishwasher-safe. Do not use metal utensils as these will damage the surface. The popping plate and stirring rod stay assembled for cleaning.

Do not put the popping plate in the dishwasher until it's cool.

TIPS AND HINTS

POPCORN AMOUNTS

Kernels	Vegetable Oil	Popped Popcorn
¼ cup	1½ teaspoons	Approximately 6 cups popped popcorn
⅓ cup	2 teaspoons	Approximately 8 cups popped popcorn
½ cup	1 tablespoon	Approximately 10 cups popped popcorn

Note: Premium popcorns have larger kernels, resulting in a higher yield of popcorn. If using premium popcorn, the yield of popped popcorn will be about 1 cup greater than stated above.

Note: DO NOT use more than ⅓ cup of unpopped kernels when using premium popcorn.

The seasoning possibilities for popcorn are endless. Just add melted butter and your favorite seasonings to a bowl of popcorn.

With toppings added, popped popcorn will become much crisper and the flavors become more intense if it is heated with desired toppings in a 300°F oven for about 15 to 20 minutes before serving. For best results, heat it on a baking sheet that you have lined with foil and sprayed with cooking oil.

Note: Serving bowl should not be put into oven.

It is very important to use fresh popcorn. If your popcorn is old, the kernels will not fully pop and/or it may take a long time for them to pop.

SEASONING SUGGESTIONS

Cheese
Taco seasoning
Chili powders
Hot sauce
Packaged sauces (i.e. Alfredo)
Soy sauce
Italian seasoning and herbs

Butter/Seasoning ratios for popcorn

2 tablespoons melted butter for ¼ cup unpopped kernels, and a minimum of 1 teaspoon of seasoning

3 tablespoons melted butter for ⅓ cup unpopped kernels, and a minimum of 2 teaspoons of seasoning

4 tablespoons melted butter for ½ cup unpopped kernels, and a minimum of 2½ teaspoons to a tablespoon of seasoning

The amount of seasoning depends on the intensity of the ingredients you are using – it is important to let your taste be your guide.

RECIPES

Southwestern Popcorn

Makes sixteen ½-cup servings

- 8 cups popped popcorn**
- ½ cup toasted pepitas**
- 3 tablespoons unsalted butter**
- 1 teaspoon chili powder**
- 1 teaspoon paprika**
- ½ teaspoon kosher salt**
- ¼ teaspoon dried oregano**
- ¼ teaspoon granulated garlic**
- ½ teaspoon cayenne pepper**

Place popcorn and pepitas in large mixing bowl. Melt the butter in a small skillet. Stir in the spices. Cook spices for about 2 minutes to release flavors. Pour butter over popcorn and toss to coat evenly. Serve.

Nutritional information per ½-cup serving:

*Calories 69 (66% from fat) • carb. 3g • pro. 3g • fat 5g
• sat. fat 2g • chol. 6mg • sod. 45mg • calc. 5mg • fiber 1g*

Wasabi Popcorn

Makes sixteen ½-cup servings

- 8 cups popped popcorn**
- 3 tablespoons butter**
- ½ teaspoon wasabi powder**
- ½ teaspoon salt**

Place the popcorn in a large mixing bowl. Melt the butter in a small skillet. Stir in the wasabi and salt and cook for about 3 minutes. Pour wasabi butter over popcorn and toss to coat evenly. Serve.

Nutritional information per ½-cup serving:

*Calories 38 (72% from fat) • carb. 2g • pro. 0g • fat 3g
• sat. fat 1g • chol. 6mg • sod. 74mg • calc. 1mg • fiber 0g*

Cheesy Popcorn

Makes sixteen ½-cup servings

Variation 1

- 8 cups popped popcorn**
- 3 tablespoons unsalted butter**
- ½ cup grated Parmesan cheese**
- ¼ teaspoon kosher salt**

Place the popcorn in a large mixing bowl. Melt the butter in a small skillet and stir in the cheese and salt. Pour butter mixture over popcorn and toss to coat evenly. Serve.

Nutritional information per ½-cup serving:

*Calories 50 (70% from fat) • carb. 2g • pro. 1g • fat 4g
• sat. fat 2g • chol. 8mg • sod. 56mg • calc. 34mg • fiber 0g*

Variation 2

- 8 cups popped popcorn**
- 3 tablespoons unsalted butter**
- 1½ tablespoons packaged cheese sauce mix**

Place the popcorn in a large mixing bowl. Melt the butter in a small skillet and stir in the cheese sauce mix. Pour butter mixture over popcorn and toss to coat evenly. Serve.

Nutritional information per ½-cup serving:

*Calories 34 (63% from fat) • carb. 3g • pro. 1g • fat 2g
• sat. fat 1g • chol. 6mg • sod. 31mg • calc. 3mg • fiber 0g*

Asian Style Popcorn

Makes sixteen ½-cup servings

- 8 cups popped popcorn**
- 3 tablespoons unsalted butter**
- 1½ tablespoons soy sauce**
- ½ teaspoon sesame oil**

Place the popcorn in a large mixing bowl. Melt the butter in a small skillet and stir in the soy sauce and sesame oil. Pour soy butter over popcorn and toss to coat evenly. Serve.

Nutritional information per ½-cup serving:

*Calories 38 (70% from fat) • carb. 2g • pro. 0g • fat 3g
• sat. fat 1g • chol. 6g • sod. 97mg • calc. 1mg • fiber 0g*

Curry Popcorn

Makes sixteen ½-cup servings

- 8 cups popped popcorn**
- 3 tablespoons unsalted butter**
- 2 teaspoons curry powder**
- ½ teaspoon turmeric**
- ½ teaspoon kosher salt**
- pinch cayenne pepper**

Place popcorn in large mixing bowl. Melt the butter in a small skillet. Stir in the spices and cook for about 2 minutes to release flavors. Pour butter over popcorn and toss to coat evenly. Serve.

Nutritional information per ½-cup serving:

*Calories 37 (69% from fat) • carb. 2g • pro. 0g • fat 3g
• sat. fat 1g • chol. 6mg • sod. 42mg • calc. 2mg • fiber 1g*

Pesto Popcorn

Makes sixteen ½-cup servings

- 8 cups popped popcorn**
- 3 tablespoons unsalted butter**
- 4 tablespoons prepared pesto
(see recipe below)**

Place the popcorn in a large mixing bowl. Melt the butter in a small skillet and stir in prepared pesto. Pour pesto butter over popcorn and toss to coat evenly. Serve.

Nutritional information per ½-cup serving:

*Calories 50 (77% from fat) • carb. 2g • pro. 1g • fat 4g
• sat. fat 2g • chol. 6mg • sod. 23mg • calc. 9mg • fiber 0g*

Pesto

Makes about ¾ cup

- 1 small clove garlic**
- 1 ounce Parmesan cheese,
cut into 1" cubes**
- 3 cups packed fresh basil**
- 1 teaspoon kosher salt**
- ½ cup extra virgin olive oil**

Insert the metal chopping blade into a food processor. With the machine running, drop the garlic down the small feed tube. Once the garlic is processed, drop the Parmesan down the small feed tube. Process for about 10 seconds. Scrape the work bowl and add the basil and salt. Process for another 5 to 10 seconds. With machine running, pour olive oil down small feed tube. Allow machine to run until mixture is emulsified, about 15 to 20 seconds.

Popcorn Snack Mix

Makes about sixteen ½-cup servings

- 6 cups popped popcorn**
- 1 cup mini pretzels or pretzel sticks**
- ¾ cup peanuts**
- ¾ cup roasted mixed nuts**
- 4 tablespoons unsalted butter**
- ½ teaspoon paprika**
- ½ teaspoon kosher salt**
- ¼ teaspoon granulated garlic**
- ½ teaspoon Worcestershire sauce**
- dash hot sauce**

Preheat oven to 300°F.

Prepare a sheet tray by lining it with foil; spray with cooking spray.

Place the popcorn, pretzels, and nuts in a large mixing bowl. Melt the butter in a small skillet and stir in the spices, Worcestershire and hot sauces. Pour butter mixture over popcorn and toss to coat evenly.

Pour mix onto prepared sheet tray. Bake for about 20 minutes, stirring occasionally. Serve.

Nutritional information per ½-cup serving:

*Calories 135 (50% from fat) • carb. 14g • pro. 3g • fat 7g
• sat. fat 2g • chol. 8mg • sod. 283mg • calc. 8mg • fiber 1g*

Buffalo Style Popcorn

Makes sixteen ½-cup servings

8 cups popped popcorn
3 tablespoons unsalted butter
1½ tablespoons hot sauce
¼ teaspoon cider vinegar

Place popcorn in large mixing bowl. Melt the butter in a small skillet and stir in the hot sauce and vinegar. Pour butter over popcorn and toss to coat evenly. Serve.

Nutritional information per ½-cup serving:

*Calories 31 (66% from fat) • carb. 2g • pro. 0g • fat 2g
• sat. fat 1g • chol. 6mg • sod. 68mg • calc. 1mg • fiber 0g*

Caramel-Nut Popcorn

Makes eighteen to twenty ½-cup servings

8 cups popped popcorn
½ cup whole almonds
½ cup roasted cashews
½ cup macadamia nuts
½ cup unsalted butter
½ cup light corn syrup
1 cup brown sugar
1 teaspoon pure vanilla extract
¼ teaspoon baking soda

Preheat oven to 300°F.

Prepare a sheet tray by lining it with foil; spray with cooking spray.

Place popcorn and nuts in a large mixing bowl that has also been sprayed with cooking spray. Reserve.

Place the butter, corn syrup, and brown sugar in a 3-quart saucepan over high heat. Bring mixture to a boil. Using a candy thermometer, bring mixture to 275°F, and remove pan from heat. Stir in vanilla and baking soda very carefully, as caramel can sputter when ingredients are added.

Pour mixture over popcorn and nuts and toss immediately with a heatproof spatula.

Pour popcorn mixture out onto prepared sheet pan and place in preheated oven. Bake for about 45 minutes, stirring every 15 minutes.

Allow to cool and then break pieces up to serve.

To make popcorn balls:

Bring the butter, sugar, corn syrup mixture to 270°–275°F. Follow the instructions as above: add the vanilla and baking soda, pour evenly over popcorn and nuts. Instead of placing in the oven, grease your hands well with butter and form the popcorn into balls. Be careful as the caramel is hot. Place on a lined baking tray and allow to cool completely. Once cool, serve or store individually wrapped in plastic.

Nutritional information per ½-cup serving:

*Calories 178 (51% from fat) • carb. 21g • pro. 3g • fat 11g
• sat. fat 4g • chol. 12mg • sod. 25 mg
• calc. 28mg • fiber 1g*

Peanut Butter Popcorn

Makes sixteen ½-cup servings

8 cups popped popcorn
½ cup light corn syrup
½ cup granulated sugar
½ cup unsalted butter
½ cup peanut butter

Preheat oven to 300°F.

Prepare a sheet tray by lining it with foil; spray with cooking spray.

Place popcorn in a large mixing bowl that has also been sprayed with cooking spray and reserve.

Place the corn syrup, sugar, and butter in a 3-quart saucepan over high heat. Bring mixture to a boil. Using a candy thermometer, bring mixture to 270°F, and remove pan from heat. Stir in peanut butter very carefully, as caramel can sputter when ingredients are added.

Pour mixture over popcorn and toss immediately with a heatproof spatula. Pour popcorn mixture out onto prepared sheet pan and place in preheated oven. Bake for about 45 minutes, stirring every 15 minutes.

Allow to cool and then break pieces up to serve.

Nutritional information per ½-cup serving:

*Calories 137 (54% from fat) • carb. 14g • pro. 2g • fat 8g
• sat. fat 4g • chol. 12mg • sod. 36mg • calc. 8mg • fiber 0g*

Chocolate Popcorn

Makes sixteen ½-cup servings

8 cups popped popcorn
1 cup roasted peanuts
4 tablespoons unsalted butter
½ cup corn syrup
½ cup granulated sugar
1 cup semisweet chocolate chips
1 teaspoon pure vanilla extract

Preheat oven to 300°F.

Prepare a sheet tray by lining it with foil; spray with cooking spray.

Place popcorn and nuts in a large mixing bowl that has also been sprayed with cooking spray. Reserve.

Place the butter, corn syrup, and sugar in a 3-quart saucepan over high heat. Bring mixture to a boil. Once all the sugar is melted, and about 5 minutes after mixture comes to a boil, stir in chocolate chips and vanilla, stirring until chocolate is melted. Pour mixture over popcorn and nuts and stir to coat as evenly as possible. Pour popcorn and chocolate into prepared sheet tray.

Bake for 1 hour, stirring mixture every 15 minutes or so.

Once cool, break popcorn up into pieces and serve.

Nutritional information per ½-cup serving:

*Calories 158 (41% from fat) • carb. 22g • pro. 2g • fat 7g
• sat. fat 2g • chol. 0g • sod. 6mg • calc. 8mg • fiber 3g*

Nutty Caramel Chocolate Popcorn Bark

Makes about 18–20 servings

8 cups popped popcorn
1 cup mixed roasted nuts
½ cup unsalted butter
1 cup light corn syrup
½ cup brown sugar
½ cup granulated sugar
1 teaspoon vanilla extract
¼ teaspoon baking soda
3 cups semisweet chocolate morsels

Preheat oven to 300°F.

Prepare a sheet tray by lining it with foil; spray with cooking spray.

Place popcorn and nuts in a large mixing bowl that has also been sprayed with cooking spray. Reserve.

Place the butter, corn syrup, brown sugar and granulated sugar in a 3-quart saucepan over high heat. Bring mixture to a boil. Using a candy thermometer, bring mixture to 275°F and remove pan from heat. Very carefully stir in vanilla and baking soda.

Pour mixture over popcorn and nuts and toss immediately with a heatproof spatula. Pour popcorn mixture out onto prepared sheet pan and place in preheated oven. Bake for about 45 minutes, stirring every 15 minutes.

Place chocolate in a double boiler to melt. When the popcorn has cooled slightly, drizzle the melted chocolate over it.

Allow to cool completely so that the chocolate hardens, and then break into pieces to serve.

Nutritional information per ½-cup serving:

*Calories 323 (48% from fat) • carb. 41g • pro. 2g • fat 18g
• sat. fat 8g • chol. 24mg • sod. 40mg
• calc. 17mg • fiber 4g*

WARRANTY

LIMITED THREE-YEAR WARRANTY

This warranty is available to consumers only. You are a consumer if you own a Cuisinart® EasyPop™ Popcorn Maker that was purchased at retail for personal, family or household use. Except as otherwise required under applicable law, this warranty is not available to retailers or other commercial purchasers or owners.

We warrant that your Cuisinart® EasyPop™ Popcorn Maker will be free of defects in materials and workmanship under normal home use for 3 years from the date of original purchase.

We suggest you complete and return the enclosed product registration card promptly to facilitate verification of the date of original purchase. However, return of the product registration card does not eliminate the need for the consumer to maintain the original proof of purchase in order to obtain the warranty benefits. In the event that you do not have proof of purchase date, the purchase date for purposes of this warranty will be the date of manufacture.

If your Cuisinart® EasyPop™ Popcorn Maker should prove to be defective within the warranty period, we will repair it, or if we think necessary, replace it. To obtain warranty service, simply call our toll-free number 1-800-726-0190 for additional information from our Customer Service Representatives, or send the defective product to Customer Service at Cuisinart, 150 Milford Road, East Windsor, NJ 08520.

To facilitate the speed and accuracy of your return, please enclose \$10.00 for shipping and handling of the product.

Please pay by check or money order (California residents need only supply proof of purchase and should call 1-800-726-0190 for shipping instructions).

NOTE: For added protection and secure handling of any Cuisinart® product that is being returned, we recommend you use a traceable, insured delivery service. Cuisinart cannot be held responsible for in-transit damage or for packages that are not delivered to us. Lost and/or damaged products are not covered under warranty. Please be sure to include your return address, daytime phone number, description of the product defect, product model number (located on bottom of product), original date of purchase, and any other information pertinent to the product's return.

Your Cuisinart® EasyPop™ Popcorn Maker has been manufactured to the strictest specifications and has been designed for use with the authorized accessories and replacement parts.

This warranty expressly excludes any defects or damages caused by accessories, replacement parts, or repair service other than those that have been authorized by Cuisinart.

This warranty does not cover any damage caused by accident, misuse, shipment or other ordinary household use.

This warranty excludes all incidental or consequential damages. Some states do not allow the exclusion or limitation of these damages, so they may not apply to you.

CALIFORNIA RESIDENTS ONLY:

California law provides that for In-Warranty Service, California residents have the option of returning a nonconforming product (A) to the store where it was purchased or (B) to another retail store which sells Cuisinart products of the same type.

The retail store shall then, at its discretion, either repair the product, refer the consumer to an independent repair facility, replace the product, or refund the purchase price less the amount directly attributable to the consumer's prior usage of the product. If the above two options do not result in the appropriate relief to the consumer, the consumer may then take the product to an independent repair facility if service or repair can be economically accomplished. Cuisinart and not the consumer will be responsible for the reasonable cost of such service, repair, replacement, or refund for nonconforming products under warranty.

California residents may also, according to their preference, return nonconforming products directly to Cuisinart for repair, or if necessary, replacement, by calling our Consumer Service Center toll-free at 1-800-726-0190.

Cuisinart will be responsible for the cost of the repair, replacement, and shipping and handling for such products under warranty.

BEFORE RETURNING YOUR CUISINART® PRODUCT

If you are experiencing problems with your Cuisinart® product, we suggest that you call our Cuisinart® Service Center at 1-800-726-0190 before returning the product serviced. If servicing is needed, a Representative can confirm whether the product is under warranty and direct you to the nearest service location.

Important: If the nonconforming product is to be serviced by someone other than Cuisinart's Authorized Service Center, please remind the servicer to call our Consumer Service Center at 1-800-726-0190 to ensure that the problem is properly diagnosed, the product is serviced with the correct parts, and the product is still under warranty.

Cuisinart®

SAVOR THE GOOD LIFE™



Cuisinart offers an extensive assortment of top quality products to make life in the kitchen easier than ever. Try some of our other countertop appliances and cookware, and Savor the Good Life™.

www.cuisinart.com

©2007 Cuisinart
Cuisinart® is a registered trademark
of Cuisinart
150 Milford Road
East Windsor, NJ 08520
Printed in China
07CU26092

Any other trademarks or service marks referred to herein are the trademarks or service marks of their respective owners.

G IB-7757

Version no.: <u>IB-7757</u>	
Size: <u>152MM(W)X203MM(H)</u> <u>12PP</u>	
Material: <u>COVER:157GSM MATT ARTPAPER</u> <u>INSIDE:120GSM GLOSS ARTPAPER</u>	
Coating: <u>VARNISHING IN COVER PAGE</u>	
Color (COVER): <u>4C(CMYK)+1C(BK)</u>	
(INSIDE): <u>1C(BK)+1C(BK)</u>	
Date: <u>MAY-15-2007</u>	Co-ordinator: <u>ASTOR</u>
Hugo Description: <u>CPM900 IB-7757(0,1) BOOK</u>	
Hugo code: <u>LEP0005IB-1-1</u>	OPERATOR:HAI

