

This Owner's Manual is provided and hosted by [Appliance Factory Parts](#).



# CUISINART WAF-8 Owner's Manual

[Shop genuine replacement parts for CUISINART WAF-8](#)



[Find Your CUISINART Small Appliance Parts - Select From 213 Models](#)

----- Manual continues below -----

# Cuisinart®

INSTRUCTION &  
RECIPE BOOKLET



**6-Slice Traditional Waffle Iron**

**WAF-6**

For your safety and continued enjoyment of this product, always read the instruction book carefully before using.

---

# IMPORTANT SAFEGUARDS

When using an electrical appliance, basic safety precautions should always be followed, including the following:

1. **READ ALL INSTRUCTIONS.**
2. Do not touch hot surfaces. Use handles and knobs.
3. To protect against fire, electrical shock, and injury to persons, **DO NOT IMMERSE CORD, PLUG, OR UNIT** in water or other liquids.
4. Close supervision is necessary when any appliance is used by or near children.
5. Unplug from outlet when not in use and before cleaning. Allow to cool before putting on or taking off parts, and before cleaning appliance.
6. Do not operate any appliance with a damaged cord or plug, or after the appliance malfunctions or has been damaged in any manner. Return appliance to the nearest Cuisinart Authorized Service Facility for examination, repair, or adjustment.
7. The use of accessory attachments not recommended by Cuisinart may result in fire, electrical shock, or injury to persons.
8. Do not use outdoors.
9. Do not let power cord hang over edge of table or counter, or touch hot surfaces.
10. Do not place on or near a hot gas or electric burner, or in a heated oven.
11. Unplug the unit when finished baking waffles.
12. Do not use appliance for other than intended use.
13. Extreme caution must be used when moving an appliance containing hot oil or other hot liquids.
14. Always attach plug to appliance first; then plug cord into the wall outlet. To disconnect, turn control dial to OFF setting; then remove plug from wall outlet.

15. **WARNING: TO REDUCE THE RISK OF FIRE OR ELECTRIC SHOCK, REPAIR SHOULD BE DONE ONLY BY AUTHORIZED PERSONNEL. DO NOT REMOVE THE BASE PANEL. NO USER SERVICEABLE PARTS ARE INSIDE.**

## SAVE THESE INSTRUCTIONS FOR HOUSEHOLD USE ONLY

### SPECIAL CORD SET INSTRUCTIONS

A short power supply cord is provided to reduce the risks resulting from becoming entangled in or tripping over a longer cord.

Longer extension cords are available and may be used if care is exercised in their use.

If a long extension cord is used, the marked electrical rating of the extension cord should be at least as great as the electrical rating of the appliance. The longer cord should be arranged so that it will not drape over the countertop or tabletop where it can be pulled on by children or animals, or tripped over.

### NOTICE

This appliance has a polarized plug (one blade is wider than the other). To reduce the risk of electric shock, this plug will fit in a polarized outlet only one way. If the plug does not fit fully in the outlet, reverse the plug. If it still does not fit, contact a qualified electrician. Do not modify the plug in any way.

## CONTENTS

Important Safeguards . . . . .	2
Introduction . . . . .	3
Parts and Features . . . . .	3
Before First Use. . . . .	3
Operating Instructions . . . . .	4
Cleaning and Care. . . . .	4
Storage . . . . .	5
Tips to Make Perfect Waffles . . . . .	5
Suggested Toppings . . . . .	5
Recipes . . . . .	5
Warranty. . . . .	11

## INTRODUCTION

Cuisinart has always had a flair for the dramatic, and your new 6-Slice Traditional Waffle Iron is one of the best examples yet! The look is solid – a cross between commercial and consumer, with brushed stainless steel that’s upscale and elegant. Smooth, flared sides add style and catch drips for easy cleanups. You’ll love the options that 6 browning settings provide, and the successful results that indicator lights and an audible tone guarantee. Your waffle iron bakes six waffles at once, so no one has to wait for fun family breakfasts or delightfully different desserts. Plates are nonstick, so just heat them up and get ready to enjoy Cuisinart at its best!

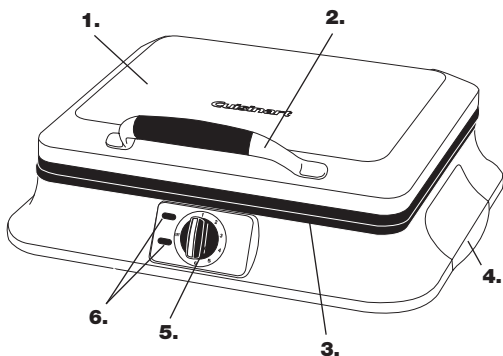

## PARTS AND FEATURES

1. **Housing** – Elegant brushed stainless steel cover and base with embossed Cuisinart logo.
2. **Lid Handle** – Polished chrome handle with cool touch grip.
3. **Baking Plates** – Die-cast aluminum plates bake six traditional-style waffles.
4. **Base Handles** – Cool-touch plastic will not become hot while baking.
5. **Control Dial** – Six adjustable browning settings and OFF position.
6. **Indicator Lights** – Red indicator light signals power on; green indicator light signals when waffle iron is ready to bake and when waffles are cooked and ready to eat.
7. **Audible Signal (not shown)** – Signals when waffle iron is ready to bake and when waffles are cooked and ready to eat.
8. **Cord Storage (not shown)** – Cord wraps under base.
9. **Rubber Feet (not shown)** – Feet keep unit steady and won’t mark countertop.

## BEFORE THE FIRST USE

Remove all packaging and any promotional labels or stickers from your waffle iron. Be sure that all parts (listed above, **Parts and Features**) of your new waffle iron have been included before discarding any packaging materials. You may want to keep the box and packing materials for use at a later date.

Before using your Cuisinart® 6-Slice Traditional Waffle Iron for the first time, remove all protective paper and wrapping. Wipe housing and waffle plates with a damp cloth to remove any dust from the warehouse or shipping.

**Note:** This Cuisinart® 6-Slice Traditional Waffle Iron has been treated with a special nonstick coating. Before the first use, we suggest you season the grids with cooking spray or oil. If using oil, apply oil with a paper towel or pastry brush. You may find it helpful to repeat this process before each use of the waffle maker.

## OPERATING INSTRUCTIONS

1. Place the closed waffle iron on a clean, flat surface where you intend to use it.
2. Plug the power cord into a standard electrical outlet.
3. Turn the control dial clockwise from the OFF position to the desired browning setting – setting #1 for the lightest color waffles and setting #6 for the darkest color waffles. We recommend using setting #3 for golden brown waffles.

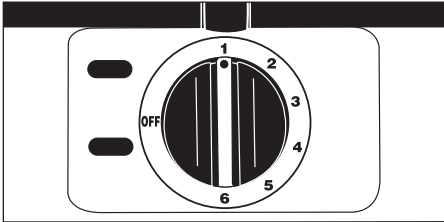

The red indicator light will turn on to signal that the power is on. Allow the waffle iron to heat. When the waffle iron has reached desired temperature, the green indicator light will turn on and the audible tone will sound. You are now ready to begin baking.

**Note:** The first time you use your waffle iron it may have a slight odor and may smoke a bit. This is normal, and common to appliances with a nonstick surface.

4. Lift lid of waffle iron by grasping the handle and pushing up in one fluid motion. Lid will stay open at a 105° position until you lower it.

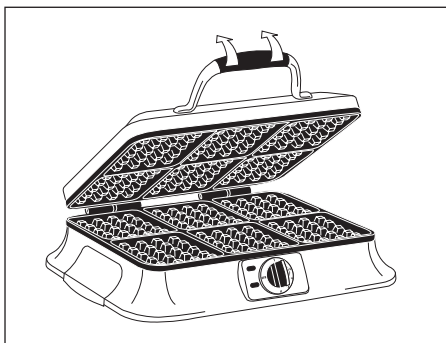

5. Pour batter onto the center of the lower waffle grid. Use a heat-proof spatula to spread batter evenly over the grid. Close the lid. The green light will turn off but the red light will stay illuminated.
6. Baking time is determined by the browning level that you chose in Step 3. It may take up to 5 minutes to bake your waffle on setting #6.
7. When the waffles are ready, the green light will turn on and the audible tone will sound. Remove waffles by gently loosening the edges with a heat-proof plastic spatula or wooden spatula. Never use metal utensils, as they will damage the nonstick coating.
8. When you are finished baking, turn the control dial counterclockwise to the OFF setting. The red indicator light will turn off. Unplug the power cord from the wall outlet. Allow the waffle iron to cool down completely before handling.

## CLEANING AND CARE

Once you have finished baking, turn the control dial to the OFF position and remove plug from electrical outlet. Leave top lid open so grids begin to cool. Allow waffle iron to cool down completely before handling.

Never take your waffle iron apart for cleaning. Simply brush crumbs from grooves, and absorb any excess cooking oil by wiping with a dry cloth or paper towel.

You may also clean the grids by wiping with a damp cloth to prevent staining and sticking from batter or oil buildup. **Be certain grids have cooled completely before cleaning.** If batter adheres to plates, simply pour a little cooking oil onto the baked batter and let stand approximately 5 minutes, allowing it to soften for easy removal.

To clean exterior, wipe with a soft dry cloth. Never use an abrasive cleanser or harsh pad. **NEVER IMMERSE CORD, PLUG OR UNIT IN WATER OR OTHER LIQUID.**

---

## STORAGE

Store unit in a cool dry place, with cord wrapped securely.

## TIPS TO MAKE PERFECT WAFFLES

We recommend setting #3 or #4 for golden brown waffles, either from mix or homemade. If you prefer crisper, darker waffles, increase the browning control.

For evenly filled waffles, pour the batter onto the center of the lower grid and spread out evenly to the edges. The entire lower grid should be filled. We recommend using 2 cups batter per batch for most recipes.

Waffles are best when made to order, but prebaked waffles may be kept warm in a 200°F oven. Place in a baking pan or wrap in foil while in the oven. Waffles wrapped in foil may lose their crispiness.

Baked waffles may be frozen. Allow to cool completely; then place in plastic food storage bag. Use waxed paper to keep waffles separated. Reheat in toaster or toaster oven when ready to use.

## SUGGESTED TOPPINGS

Maple syrup, fruit syrups  
Warm fruit compote, fruit sauce  
Fresh berries, chopped fruit  
Chopped nuts  
Powdered sugar  
Whipped cream  
Ice cream, sorbet  
Chocolate sauce  
Fruited yogurt

## RECIPES

### BASIC WAFFLES

Fresh, homemade waffles make breakfast a special occasion. Freeze the extras to use when time is short.

Makes 24 waffles

**6 cups all-purpose flour**  
**¼ cup plus 2 tablespoons granulated sugar**  
**3 tablespoons baking powder**  
**1½ teaspoons baking soda**  
**1½ teaspoons salt**  
**5¼ cups lowfat milk**  
**1 cup plus 2 tablespoons vegetable oil**  
**6 large eggs**

Place ingredients in a large mixing bowl and combine until well blended and smooth. Let batter rest 5 minutes before using. Preheat your Cuisinart® Waffle Iron.

When preheated, green indicator light will illuminate. Pour 2 cups of batter evenly over the lower grid; spread batter using a heat-proof spatula to within ½ inch of the edge of the grid. Close lid of waffle iron – green indicator light will turn off. When green indicator light turns on again, waffle is ready. Open lid and carefully remove baked waffle. Repeat with remaining batter. For best results, serve immediately.

*Nutritional information per waffle:*

*Calories 262 (44% from fat) • carb. 30g • pro. 7g  
• fat 13g • sat. fat 2g • chol. 57mg • sod. 372mg  
• calc. 177mg • fiber 1g*

### CHOCOLATE BROWNIE WAFFLES

A treat for breakfast or dessert.

Makes 24 waffles

**4 cups all-purpose flour**  
**1½ cups granulated sugar**  
**1½ cups unsweetened cocoa powder**  
**2 tablespoons baking powder**  
**1 teaspoon baking soda**  
**1 teaspoon salt**  
**1 teaspoon cinnamon**  
**4 cups reduced-fat milk (may use evaporated fat free milk)**  
**4 large eggs**  
**2 teaspoons vanilla extract**  
**8 tablespoons unsalted butter, melted, cooled slightly**  
**1½ cups semisweet mini chocolate morsels**  
**1 cup finely chopped walnuts or pecans**

Place the flour, sugar, cocoa powder, baking powder, baking soda, salt, and cinnamon in a

medium bowl; stir with a whisk to blend. Add the milk, eggs and vanilla. Stir with a whisk until well blended and smooth. Stir in melted butter. Let batter stand 5 minutes. Preheat Cuisinart® Waffle Iron on setting #4.

When preheated, green indicator light will illuminate. Stir chocolate morsels and chopped walnuts/pecans into batter. Pour 2 cups of batter along center of lower grid. Let batter spread out from center slightly – for 5 to 10 seconds. Close lid of waffle iron – green indicator light will turn off. When green indicator light turns on again, waffle is ready. Remove waffle using a heat-proof plastic spatula. Repeat with remaining batter. For best results, serve immediately.

*Nutritional information per waffle:*

*Calories 315 (44% from fat) • carb. 39g • pro. 7g  
• fat 17g • sat. fat 8g • chol. 59mg • sod. 238mg  
• calc. 73mg • fiber 3g*

## NUTTY WHEAT WAFFLES

Wholesome wheat flavor combines with crunchy nuts for a delicious breakfast, brunch or snack. Top with warm syrup or fruit compote.

Makes 30 waffles

- 4½ cups all-purpose flour**
- 1½ cups whole wheat flour**
- ¼ cup plus 2 tablespoons granulated sugar**
- 3 tablespoons baking powder**
- 1½ teaspoons salt**
- 6 cups reduced-fat milk**
- 1 cup plus 2 tablespoons vegetable oil**
- 6 large eggs**
- 1½ cups finely chopped nuts, such as pecans, walnuts, almonds or hazelnuts**

Place ingredients in a large mixing bowl and combine until well blended and smooth. Let batter rest 5 minutes before using. Preheat your Cuisinart® Waffle Iron on setting #3.

When preheated, green indicator light will illuminate. Pour 2 cups of batter along the center of the lower grid; spread batter using a heat-proof spatula to within ½ inch of the edge of the grid. Close lid of waffle iron – green indicator light will turn off. When green indicator light turns on again, waffle is ready. Open lid and carefully remove baked waffle. Repeat with remaining batter. For best results, serve immediately.

*Nutritional information per waffle:*

*Calories 248 (55% from fat) • carb. 24g • pro. 7g  
• fat 14g • sat. fat 2g • chol. 46mg • sod. 354mg  
• calc. 74mg • fiber 2g*

## CINNAMON PECAN WAFFLES

Top these tasty waffles with warm maple syrup and fresh fruit.

Makes 30 waffles

- 6 tablespoons packed light brown sugar**
- 6 cups all-purpose flour**
- 3 tablespoons baking powder**
- 4½ teaspoons ground cinnamon**
- 1½ teaspoons baking soda**
- 1½ teaspoons salt**
- 5½ cups reduced-fat milk**
- 1 cup plus 2 tablespoons vegetable oil**
- 6 large eggs, lightly beaten**
- 3 cups chopped pecans**

Crumble the brown sugar to remove all lumps and place in a medium mixing bowl with the flour, baking powder, cinnamon, baking soda, and salt. Combine the milk, oil and eggs; stir until blended and smooth. Add to the dry ingredients and stir until smooth. Stir in the chopped pecans. Let batter rest 5 minutes before using. Preheat your Cuisinart® Waffle Iron on setting #3.

When preheated, green indicator light will illuminate. Pour 2 cups of batter along the center of the lower grid; spread batter using a heatproof spatula to within ½ inch of the edge of the grid. Close lid of waffle iron – green indicator light will turn off. When green indicator light turns on again, waffle is ready. Open lid and carefully remove baked waffle. Repeat with remaining batter. For best results, serve immediately.

*Nutritional information per waffle:*

*Calories 283 (55% from fat) • carb. 26g • pro. 6g  
• fat 18g • sat. fat 2g • chol. 46mg • sod. 277mg  
• calc. 71 mg • fiber 2g*

## APPLE WALNUT WAFFLES

Stir a teaspoon of cinnamon into maple syrup and warm to serve with Apple Walnut Waffles.

Makes 24 waffles

- ½ cup plus 1 tablespoon packed brown sugar**

- 4 cups all-purpose flour
- ¾ cup whole wheat flour
- ¾ cup honey toasted wheat germ
- 3 tablespoons baking powder
- 1½ teaspoons salt
- 4½ cups lowfat milk
- 6 large eggs, lightly beaten
- 1 cup vegetable oil
- 1½ teaspoons vanilla extract
- 3 cups finely diced or shredded apple (1 apple, 8 ounces, peeled and cored)
- 1½ cups finely chopped walnuts

Crumble the brown sugar into a medium bowl to remove all lumps. Add the flours, wheat germ, baking powder and salt. Stir to blend. In another bowl, combine the milk, eggs, oil, and vanilla; stir with a whisk. Add the wet mixture to the dry mixture and stir until smooth. Stir in the apple and walnuts. Let batter rest 5 minutes before using. Preheat your Cuisinart® Waffle Iron on setting #3.

When preheated, green indicator light will illuminate. Pour 2 cups of batter along the center of the lower grid; spread batter using a heatproof spatula to within ½ inch of the edge of the grid. Close lid of waffle iron – green indicator light will turn off. When green indicator light turns on again, waffle is ready. Open lid and carefully remove baked waffle. Repeat with remaining batter. For best results, serve immediately.

*Nutritional information per waffle:*  
 Calories 305 (48% from fat) • carb. 33g • pro. 8g  
 • fat 16g • sat. fat 2g • chol. 57mg • sod. 319mg  
 • calc. 85mg • fiber 2g

## BANANA WALNUT WAFFLES

Classic waffles for a weekend brunch.

Makes 24 waffles

- 4 cups all-purpose flour
- 4 tablespoons granulated sugar
- 2 tablespoons baking soda
- 1 teaspoon salt
- 4 eggs, lightly beaten
- ¾ cup vegetable oil
- 2 cups vanilla yogurt, lowfat
- 1½ cups whole milk
- 2 cups banana, mashed
- 1 cup walnuts, chopped

Combine flour, sugar, baking soda, and salt in a mixing bowl and stir to combine. In a separate bowl whisk together the eggs and oil and stir into dry ingredients. Stir in yogurt and then milk until mixture is a smooth batter. Stir in banana and walnuts until incorporated. Let batter rest 5 minutes before using. Preheat your Cuisinart® Waffle Iron on setting #3.

When preheated, green indicator light will illuminate. Pour 2 cups of batter onto the center of the lower grid. Allow batter to spread toward edges for 5 seconds. Close lid of waffle iron – green indicator light will turn off. When green indicator light turns on again, waffle is ready. Open lid and carefully remove baked waffle. Repeat with remaining batter. For best results, serve immediately.

*Nutritional information per waffle:*  
 Calories 223 (47% from fat) • carb. 25g • pro. 5g  
 • fat 12g • sat. fat 2g • chol. 38mg • sod. 403mg  
 • calc. 63mg • fiber 1g

## PUMPKIN WALNUT WAFFLES

For a change, you may substitute dried cranberries, raisins or even mini chocolate morsels for the walnuts.

Makes 18 waffles

- 3½ cups reduced-fat milk
- 1½ cups solid pack pumpkin\* (not pumpkin pie filling)
- ¾ cup vegetable oil
- 4 large eggs, lightly beaten
- 4½ cups all-purpose flour
- ½ cup packed light brown sugar
- 2 tablespoons baking powder
- 1 teaspoon baking soda
- 2 teaspoons ground cinnamon
- ½ teaspoon salt
- 1½ cups chopped walnuts

Place the milk, pumpkin, oil, and eggs in a bowl. Stir until smooth; reserve. Place the flour in a large bowl. Crumble the brown sugar to remove the lumps; add to the flour along with the baking powder, baking soda, cinnamon, and salt. Stir to blend. Add the liquid ingredients and whisk until smooth. Let batter rest 5 minutes before using. Preheat your Cuisinart® Waffle Iron on setting #3.

When preheated, green indicator light will illuminate. Stir walnuts into batter. Pour 2 cups of batter along the center of the lower grid. Allow batter to spread toward edges for 5 sec-

onds. Close lid of waffle iron – green indicator light will turn off. When green indicator light turns on again, waffle is ready. Open lid and carefully remove baked waffle. Repeat with remaining batter. For best results, serve immediately.

\*This is a little less than half of a 15-ounce can. Measure out  $\frac{3}{4}$  cup of the remaining pumpkin and freeze to make these waffles at another time.

*Nutritional information per waffle:*

*Calories 307 (51% from fat) • carb. 30g • pro. 8g  
• fat 18g • sat. fat 3g • chol. 51mg • sod. 269 mg  
• calc. 86 mg • fiber 2g*

## OATMEAL RAISIN WAFFLES

These waffles taste like an oatmeal raisin cookie. They are delicious when spread with apple butter.

Makes 18 waffles

- $\frac{1}{4}$  **cup plus 2 tablespoons packed light brown sugar**
- 3 cups all-purpose flour**
- 2 cups oatmeal (regular rolled oats, not quick oats)**
- 4 teaspoons ground cinnamon**
- 1 tablespoon baking powder**
- 2 teaspoons baking soda**
- 1 teaspoon salt**
- 3 cups buttermilk**
- 4 large eggs, lightly beaten**
- $\frac{3}{4}$  **cup vegetable oil (you may substitute unsalted butter, melted and cooled)**
- 1 teaspoon vanilla extract**
- 1 $\frac{1}{2}$  cups raisins**

Crumble the brown sugar to remove any lumps and place in a medium bowl with flour, oatmeal, cinnamon, baking powder, baking soda, and salt. Stir to blend. Add buttermilk, eggs, oil, and vanilla. Stir until well blended and smooth. Stir in raisins. Let batter rest 5 minutes before using. Preheat your Cuisinart® Waffle Iron on setting #3.

When preheated, green indicator light will illuminate. Pour 2 cups of batter along the center of the lower grid; spread batter using a heatproof spatula to within  $\frac{1}{2}$  inch of the edge of the grid. Close lid of waffle iron – green indicator light will turn off. When green indicator light turns on again, waffle is ready. Open lid and remove baked waffle. Repeat with remaining batter. For best results, serve immediately.

*Nutritional information per waffle:*  
*Calories 278 (36% from fat) • carb. 38g • pro. 7g  
• fat 11g • sat. fat 2g • chol. 49mg • sod. 351mg  
• calc. 77mg • fiber 2g*

## CHOCOLATE BUTTERMILK WAFFLES

Great for breakfast, or try as a base for a hot fudge sundae.

Makes 24 waffles

- 3 cups all-purpose flour**
- 1 cup unsweetened cocoa, sifted**
- $\frac{1}{4}$  **cup granulated sugar**
- $\frac{1}{4}$  **cup light brown sugar, packed**
- 4 teaspoons baking soda**
- 1 teaspoon salt**
- 4 eggs, lightly beaten**
- 2 teaspoons vanilla extract**
- $\frac{3}{4}$  **cup unsalted butter, melted, cooled slightly**
- 2 cups buttermilk**
- 2 cups lowfat yogurt (plain or vanilla)**
- 2 cups semisweet chocolate chips**

Place flour, cocoa, sugars, baking soda, and salt in a medium mixing bowl. Stir to combine. Stir in eggs, vanilla, butter, buttermilk, and yogurt successively, making sure each ingredient is incorporated well. Finally stir chocolate chips into batter. Let batter rest 5 minutes before using. Preheat your Cuisinart® Waffle Iron on setting #3.

When preheated, green indicator light will illuminate. Pour 2 cups of batter along the center of the lower grid. Allow batter to spread toward edges for 5 seconds. Close lid of waffle iron – green indicator light will turn off. When green indicator light turns on again, waffle is ready. Open lid and carefully remove baked waffle. Repeat with remaining batter. For best results, serve immediately.

*Nutritional information per waffle:*  
*Calories 267 (43% from fat) • carb. 34g • pro. 5g  
• fat 13g • sat. fat 7g • chol. 53 mg • sod. 327mg  
• calc. 71mg • fiber 4g*

## LEMON WAFFLES

Makes 30 waffles

- 3 cups all-purpose flour**
- $\frac{3}{4}$  **cup granulated sugar**

- 4 teaspoons baking soda
- 1 teaspoon salt
- 4 eggs
- 2 cups buttermilk
- 2 teaspoons pure vanilla extract
- ¼ cup fresh lemon juice
- 2 tablespoons lemon zest, finely chopped
- ¾ cup unsalted butter, melted, cooled slightly
- 2 cups vanilla yogurt

Place flour, sugar, baking soda, and salt in mixing bowl and stir to combine. In a second bowl, whisk eggs, buttermilk, and vanilla until blended. Stir into dry ingredients. Stir in lemon juice and zest. Fold in melted butter and then vanilla yogurt with a rubber spatula or wooden spoon. Let batter rest a few minutes before using. Preheat your Cuisinart® Waffle Iron on setting #3.

When preheated, green indicator light will illuminate. Pour 2 cups of batter onto the center of the lower grid. Allow batter to spread toward edges for 5 seconds. Close lid of waffle iron – green indicator light will turn off. When green indicator light turns on again, waffle is ready. Open lid and carefully remove baked waffle. Repeat with remaining batter. For best results, serve immediately.

**Variations: For lemon ginger waffles**, add 1 tablespoon of grated fresh ginger to the batter with the juice and zest. **For lemon blueberry waffles**, add 2 cups of blueberries to the batter as the last ingredient.

*Nutritional information per waffle:*  
 Calories 135 (38% from fat) • carb. 18g • pro. 3g  
 • fat 6g • sat. fat 3g • chol. 42mg • sod. 182mg  
 • calc. 52mg • fiber 0g

## SUPER MULTIGRAIN WAFFLES

These crispy waffles have a nice texture and pleasant flavor; you would never know they are good for you.

Makes 24 waffles

- 2 cups whole wheat flour
- 1 cup all-purpose flour
- 1 cup old-fashioned oats
- 2 teaspoons baking powder
- 2 teaspoons baking soda
- 1 teaspoon salt
- 4 eggs, lightly beaten
- 2 cups soy milk

- ¼ cup pure maple syrup
- 2 teaspoons vanilla extract
- ¾ cup unsalted butter, melted, cooled slightly
- ¼ cup flax seed oil
- 2 cups lowfat plain yogurt/cottage cheese
- 1 cup pecans or walnuts, finely chopped (optional)

Place whole wheat flour, unbleached flour, oats, baking powder, baking soda, and salt in mixing bowl and stir to combine. In a separate bowl stir together eggs, soy milk, syrup, and vanilla and add to the dry ingredients. Stir in butter, flax seed oil, and yogurt/cottage cheese. Finally stir chopped nuts into batter. Let batter rest 5 minutes before using. Preheat your Cuisinart® Waffle Iron on setting #3.

When preheated, green indicator light will illuminate. Pour 2 cups of batter along the center of the lower grid. Allow batter to spread toward edges for 5 seconds. Close lid of waffle iron – green indicator light will turn off. When green indicator light turns on again, waffle is ready. Open lid and carefully remove baked waffle. Repeat with remaining batter. For best results, serve immediately.

*Nutritional information per waffle with yogurt:*  
 Calories 105 (17% from fat) • carb. 17g • pro. 5g  
 • fat 2g • sat. fat 0g • chol. 36mg • sod. 243mg  
 • calc. 58mg • fiber 2g

*With 1%-fat cottage cheese:*  
 Calories 116 (17% from fat) • carb. 17g • pro. 7g  
 • fat 2g • sat. fat 1g • chol. 36mg • sod. 307mg  
 • calc. 33mg • fiber 2g

## VANILLA YOGURT PECAN WAFFLES

These waffles have a subtle, nutty sweetness and are nice and crispy.

Makes 24 waffles

- 2 cups all-purpose flour
- 2 cups whole wheat flour
- ¼ cup plus 2 tablespoons light brown sugar, firmly packed
- 4 teaspoons baking soda
- 1 teaspoon cinnamon
- 1 teaspoon salt
- 4 eggs, lightly beaten
- 2 teaspoons vanilla extract
- ¾ cup unsalted butter, melted, cooled slightly

- 2 cups vanilla yogurt, lowfat**
- 2 cups reduced-fat milk**
- 1 cup pecans, chopped**

Place both flours, sugar, baking soda, cinnamon, and salt in a mixing bowl and stir to combine. Stir eggs and vanilla together and then stir into dry ingredients. Stir butter, yogurt, and milk into mixture successively until it is a smooth batter. Finally stir in chopped pecans. Let batter rest 5 minutes before using. Preheat your Cuisinart® Waffle Iron on setting #3.

When preheated, green indicator light will illuminate. Pour 2 cups of batter onto the center of the lower grid. Allow batter to spread toward edges for 5 seconds. Close lid of waffle iron – green indicator light will turn off. When green indicator light turns on again, waffle is ready. Open lid and carefully remove baked waffle. Repeat with remaining batter. For best results, serve immediately.

*Nutritional information per waffle:*  
 Calories 204 (46% from fat) • carb. 22g • pro. 6g  
 • fat 11g • sat. fat 5g • chol. 53mg • sod. 316mg  
 • calc. 73mg • fiber 2g

## WHOLE WHEAT BERRY WAFFLES

Any type of berry will work for this versatile waffle.

Makes 24 waffles

- 2½ cups all-purpose flour**
- 1½ cups whole wheat flour**
- ¼ cup granulated sugar**
- 2 tablespoons baking powder**
- 2 teaspoons salt**
- 4 eggs, lightly beaten**
- 3½ cups whole milk**
- 2 teaspoons pure vanilla extract**
- ¼ cup unsalted butter, melted, cooled slightly**
- 1½ cups blueberries, fresh or frozen**
- 2 teaspoons orange zest**
- 1 cup pecans, chopped**

Place both flours, sugar, baking powder, and salt in a mixing bowl and stir to combine. In a separate bowl whisk together eggs, milk and vanilla and stir into dry ingredients until mixture resembles a smooth batter. Stir in melted and cooled butter. Carefully stir in blueberries, orange zest, and pecans. Let batter rest 5 minutes before using. Preheat your Cuisinart® Waffle Iron on setting #3.

When preheated, green indicator light will illuminate. Pour 2 cups of batter along the center of the lower grid. Allow batter to spread toward edges for 5 seconds. Close lid of waffle iron – green indicator light will turn off. When green indicator light turns on again, waffle is ready. Open lid and carefully remove baked waffle. Repeat with remaining batter. For best results, serve immediately.

*Nutritional information per waffle:*  
 Calories 201 (49% from fat) • carb. 21g • pro. 5g  
 • fat 11g • sat. fat 5g • chol. 58mg • sod. 283mg  
 • calc. 55mg • fiber 2g

## SAVORY CHEDDAR CHIVE CORNMEAL WAFFLES

These crispy, savory waffles are good to serve with soups or your favorite chili in place of corn muffins. You may also try them with scrambled eggs and bacon for brunch or supper.

Makes 30 waffles

- ¾ cups all-purpose flour**
- 3 cups cornmeal (yellow or white)**
- 3 tablespoons granulated sugar**
- 3 tablespoons baking powder**
- 1½ teaspoons baking soda**
- ¼ teaspoon salt**
- 9 ounces shredded sharp Cheddar cheese (about ¾ cup)**
- ¼ cup plus 2 tablespoons chopped fresh chives**
- 5¼ cups reduced-fat milk**
- ¼ cup vegetable oil**
- 6 large eggs**
- ½ teaspoon hot sauce, such as Tabasco®**

Place flour, cornmeal, sugar, baking powder, baking soda, and salt in a large mixing bowl; stir to combine. Add shredded Cheddar and chopped chives; stir. Place the milk, oil, eggs, and hot sauce a separate bowl; stir with a whisk to blend. Add to the dry ingredients and stir until smooth. Let batter rest 5 minutes before using. Preheat your Cuisinart® Waffle Iron on setting #3.

When preheated, green indicator light will illuminate. Pour 2 cups of batter just along the center of the lower grid; allow batter to spread toward edges for 5 seconds. Close lid of waffle iron – green indicator light will turn off. When green indicator light turns on again, waffle is ready. Open lid and carefully remove bake

waffle. Repeat with remaining batter. For best results, serve immediately.

*Nutritional information per waffle:*

Calories 239 (47% from fat) • carb. 25g • pro. 8g  
• fat 12g • sat. fat 2g • chol. 50mg • sod. 262 mg  
• calc. 121mg • fiber 1g

Tabasco® is a registered trademark owned by the  
McIlhenney Co.

## PROTEIN WAFFLES

These oatmeal waffles have a delightful taste, not to mention they are high in protein and very easy to prepare.

Makes 18 waffles

- 3 cups old-fashioned oats**
- 1½ cups all-purpose flour**
- ¼ cup plus 2 tablespoons sugar**
- 4 teaspoons baking powder**
- 1 teaspoon cinnamon**
- 1 teaspoon salt**
- 4 eggs, lightly beaten**
- ¾ cup vegetable oil**
- 1 cup cottage cheese**
- 2 cups reduced-fat milk**

Place oats, flour, sugar, baking powder, cinnamon, and salt in a mixing bowl. Stir to combine. Stir in remaining ingredients as listed one at a time until mixture is a smooth batter. Let batter rest 5 minutes before using. Preheat your Cuisinart® Waffle Iron on setting #3.

Pour 2 cups of batter along the center of the lower grid. Allow batter to spread toward edges for 5 seconds. Close lid of waffle iron – green indicator light will turn off. When green indicator light turns on again, waffle is ready. Open lid and carefully remove baked waffle. Repeat with remaining batter. For best results, serve immediately.

*Nutritional information per waffle:*

Calories 228 (45% from fat) • carb. 23g • pro. 7g  
• fat 12g • sat. fat 2g • chol. 50mg • sod. 261mg  
• calc. 57mg • fiber 2g

## WARRANTY Limited Three-Year Warranty

This warranty is available to consumers only. You are a consumer if you own a Cuisinart® 6-Slice Traditional Waffle Iron which was purchased at retail for personal, family or household use. Except as otherwise required under applicable law, this warranty is not available to retailers or other commercial purchasers or owners. We warrant that your Cuisinart® 6-Slice

Traditional Waffle Iron will be free of defects in materials and workmanship under normal home use for 3 years from the date of original purchase. We suggest you complete and return the enclosed product registration card promptly to facilitate verification of the date of original purchase. However, return of the product registration card does not eliminate the need for the consumer to maintain the original proof of purchase in order to obtain the warranty benefits. In the event that you do not have proof of purchase date, the purchase date for purposes of this warranty will be the date of manufacture. If your Cuisinart® 6-Slice Traditional Waffle Iron should prove to be defective within the warranty period, we will repair or, if we think necessary, replace it. To obtain warranty service, please call our Customer Service Center toll-free at 1-800-726-0190 or write to: Cuisinart, 150 Milford Road, East Windsor, NJ 08520. To facilitate the speed and accuracy of your return, enclose \$10.00 for shipping and handling. (California residents need only supply a proof of purchase and should call 1-800-726-0190 for shipping instructions.) Please be sure to include your return address, description of the product's defect, product serial number, and any other information pertinent to the return. Please pay by check or money order. **NOTE:** For added protection and secure handling of any Cuisinart® product that is being returned, we recommend you use a traceable, insured delivery service. Cuisinart cannot be held responsible for in-transit damage or for packages that are not delivered to us. Lost and/or damaged products are not covered under warranty. Your Cuisinart® 6-Slice Traditional Waffle Iron has been manufactured to the strictest specifications and has been designed for use only with authorized accessories and replacement parts. This warranty expressly excludes any defects or damages caused by accessories, replacement parts or repair service other than those authorized by Cuisinart. This warranty does not cover any damage caused by accident, misuse, shipment or other than ordinary household use. This warranty excludes all incidental or consequential damages. Some states do not allow the exclusion or limitation of these damages, so they may not apply to you.

### CALIFORNIA RESIDENTS ONLY

California law provides that for In-Warranty Service, California residents have the option of returning a nonconforming product (A) to the store where it was purchased or (B) to another retail store which sells Cuisinart® products of the same type. The retail store shall then, according to its preference, either repair the product, refer the consumer to an independent repair facility, replace the product, or refund the purchase price less the amount directly attributable to the consumer's prior usage of the product. If either of the above two options does not result in the appropriate relief to the consumer, the consumer may then take the product to an independent repair facility if service or repair can be economically accomplished. Cuisinart and not the consumer will be responsible for the reasonable cost of such service, repair, replacement, or refund for nonconforming products under warranty. California residents may also, according to their preference, return nonconforming products directly to Cuisinart for repair or, if necessary, replacement by calling our Consumer Service Center toll-free at 800-726-0190. Cuisinart will be responsible for the cost of the repair, replacement, and shipping and handling for such nonconforming products under warranty.

### BEFORE RETURNING YOUR CUISINART® PRODUCT

Important: If the nonconforming product is to be serviced by someone other than Cuisinart's Authorized Service Center, please remind the servicer to call our Consumer Service Center to ensure that the problem is properly diagnosed, the product serviced with the correct parts, and to ensure that the product is still under warranty. \*Important: If the nonconforming product is to be serviced by someone other than Cuisinart's Authorized Service Center, please remind the servicer to call our Consumer Service Center at 1-800-726-0190 to ensure that the problem is properly diagnosed, the product is serviced with the correct parts, and to ensure that the product is still under warranty.

# Cuisinart®

SAVOR THE GOOD LIFE®



Cuisinart offers an extensive assortment of top quality products to make life in the kitchen easier than ever. Try some of our other countertop appliances and cookware, and Savor the Good Life®.

**[www.cuisinart.com](http://www.cuisinart.com)**

©2006 Cuisinart  
Cuisinart® is a registered  
trademark of Cuisinart

150 Milford Road  
East Windsor, NJ 08520  
Printed in China

06CU26184

G IB-5287A-TK

Version No.: IB-5287A-TK	
Size: 152MM(W)X203MM(H)	12PP (SADDLE STITCHED)
Material: <u>Cover:</u> 157GSM MATT ARTPAPER	
<u>Inside:</u> 120GSM GLOSS ARTPAPER	
Coating: VARNISHING	
Color (Cover): 4C(CMYK)+1C(BK)	
(Inside): 1C(BK)+1C(BK)	
Date: JUL-03-2006	Co-ordinator : TH LIN
Hugo Descriptio :WAF6 IB-5287A-TK (1,1) BOOK	
Hugo Code: TKL0033IB-1-1	OPERATOR: HAI

