

This Owner's Manual is provided and hosted by [Appliance Factory Parts](#).



CUISINART WMR-CA Owner's Manual

[Shop genuine replacement parts for CUISINART
WMR-CA](#)



[Find Your CUISINART Small Appliance Parts - Select From 213 Models](#)

----- Manual continues below -----

Cuisinart®

INSTRUCTION
BOOKLET



Classic Waffle Maker

WMR-CA

For your safety and continued enjoyment of this product, always read the instruction book carefully before using.

TABLE OF CONTENTS

Important Safeguards	Page 2
Instructions for Use	Page 3
Special Features	Page 3
Tips and Toppings	Page 4
Recipes	Page 4
Cleaning and Maintenance	Page 7
Storage	Page 7
Warranty	Page 7

IMPORTANT SAFEGUARDS

When using an electrical appliance, basic safety precautions should always be followed, including the following:

- 1. READ ALL INSTRUCTIONS.**
2. Do not touch hot surfaces. Use handles and knobs.
3. To protect against fire, electrical shock, and injury to persons, **DO NOT IMMERSE CORD, PLUG, OR UNIT** in water or other liquids.
4. Close supervision is necessary when any appliance is used by or near children.
5. Unplug from outlet when not in use and before cleaning. Allow to cool before putting on or taking off parts, and before cleaning appliance.
6. Do not operate any appliance with a damaged cord or plug or after the appliance malfunctions or has been damaged in any manner. Return appliance to the nearest Cuisinart Authorized Service Facility for examination, repair, or adjustment.
7. The use of accessory attachments not recommended by Cuisinart may result in fire, electrical shock, or injury to persons.
8. Do not use outdoors.
9. Do not let power cord hang over edge of table or counter, or touch hot surfaces.
10. Do not place on or near a hot gas or electric burner, or in a heated oven.
11. Unplug the unit when finished baking waffles.
12. Do not use appliance for other than intended use.

13. Always attach plug to appliance first, then plug cord into the wall outlet. To disconnect, turn control to setting #1, then remove plug from the outlet.
14. Extreme caution must be used when moving an appliance containing hot oil or other hot liquids.
15. **WARNING: TO REDUCE THE RISK OF FIRE OR ELECTRIC SHOCK, REPAIR SHOULD BE DONE ONLY BY AUTHORIZED PERSONNEL. NO USER SERVICEABLE PARTS ARE INSIDE.**

SAVE THESE INSTRUCTIONS FOR HOUSEHOLD USE ONLY

SPECIAL CORD SET INSTRUCTIONS

A short power-supply cord is provided to reduce the risks resulting from becoming entangled in or tripping over a longer cord.

Longer extension cords are available and may be used if care is exercised in their use.

If a long extension cord is used, the marked electrical rating of the extension cord should be at least as great as the electrical rating of the appliance, and the longer cord should be arranged so that it will not drape over the countertop or tabletop where it can be pulled on by children or animals, or tripped over.

NOTICE:

This appliance has a polarized plug (one blade is wider than the other). To reduce the risk of electric shock, this plug will fit in a polarized outlet only one way. If the plug does not fit fully in the outlet, reverse the plug. If it still does not fit, contact a qualified electrician. Do not modify the plug in any way.

INSTRUCTIONS FOR USE

1. Before using your Cuisinart® Classic Waffle Maker for the first time, remove any dust from shipping by wiping the plates with a damp cloth. Remove all protective paper and wrapping.
2. Preheat the waffle. Close grids and plug cord into a 120V AC wall outlet. The red light will go on to signal power. Allow the waffle maker to preheat. The green indicator light will go on when it is ready to use.

Note: The first time you use your waffle maker, it may have a slight odor and may smoke a bit. This is normal, and common to appliances with a nonstick surface.

3. Pour batter when green indicator light goes on. Pour batter onto the center of the lower waffle grid. Use a heat-proof plastic spatula to spread batter evenly over the grids. Close the lid.
4. The green light will go off and the red light will once again illuminate. It may take several seconds for the red light to come on. This is normal.
5. Once the waffles are ready to eat, the green light will again come on.
6. Baking time is determined by browning level. Choose a setting on the browning control dial. We recommend using setting #3 for golden brown waffles.
7. Once the waffle is ready, remove it by gently loosening the edges with a heat-proof plastic spatula. Never use metal utensils, as they may damage the nonstick coating.
8. Always disconnect the plug from the wall outlet once baking is completed.

SPECIAL FEATURES

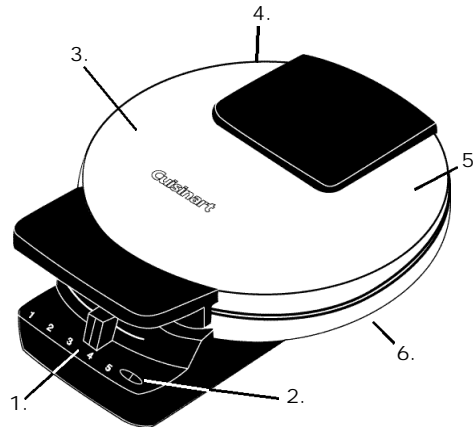

1. Browning Control Adjustment
- five settings to customize waffle maker from light to deep golden brown
2. Indicator Lights
- signal when waffle maker is ready to bake
- signal when waffles are ready to eat
3. Weighted Lid
- lid will not rise as waffles bake
4. Rubber Feet
- will not mark countertop
- keep unit steady
5. Brushed Stainless Steel Covers
Cord Storage
- cord wraps under bottom for easy storage

Note: The Cuisinart® Classic Waffle Maker has been treated with a special nonstick coating. Before the first use, we suggest you season the grids with cooking spray or flavorless vegetable oil. If using oil, apply oil with a paper towel or pastry brush. You may find it helpful to repeat this process before each use of the waffle maker.

TIPS TO MAKE PERFECT WAFFLES

We recommend setting #3 for golden brown waffles.

If you prefer crisper, darker waffles, increase the browning control to setting #4 or 5.

For evenly filled waffles, pour the batter onto the center of the lower grid and close the cover.

We recommend using 1/2 cup batter per waffle for evenly filled waffles.

Waffles are best when made to order, but baked waffles may be kept warm in a 200°F oven.

Place in a baking pan or wrap in foil while in the oven. Waffles wrapped in foil may lose their crispiness.

Baked waffles may be frozen. Allow to cool completely, then place in plastic food storage bag. Use waxed paper to keep waffles separated. Reheat in a toaster or toaster oven when ready to use.

SUGGESTED TOPPINGS

Maple syrup, fruit syrups

Warm fruit compote, fruit sauce

Fresh berries, chopped fruit, chopped nuts

Powdered sugar

Whipped cream, ice cream, sorbet

Chocolate sauce

Fruited yogurt

RECIPES

BASIC WAFFLES

You can't beat the taste of homemade waffles. Freeze the extras to use when time is scarce.

Makes eight 6-1/2-inch round waffles

- 2 cups all-purpose flour
- 2 tablespoons sugar
- 1 tablespoon baking powder
- 1/2 teaspoon salt
- 1-3/4 cups reduced fat milk
- 6 tablespoons vegetable oil
- 2 large eggs

Place ingredients in a large mixing bowl and combine until well blended and smooth. Let batter sit 5 minutes before using. Preheat your Cuisinart® Classic Waffle Maker on setting #3 *(green indicator light will be illuminated when preheated).

Pour 1/2 cup batter onto the center of the lower grid; spread evenly using a heat-proof spatula. Close cover of waffle maker. Indicator light will turn red. When light turns green again, waffle is ready. Open cover and carefully remove baked waffle. Repeat with remaining batter. For best results, serve immediately. However, you may keep waffles warm in a 200°F oven until ready to serve.

* We recommend using setting #3 to achieve a golden brown baked waffle. Adjust the browning control if you prefer lighter or darker waffles.

Nutritional information per waffle:
Calories 262 (44% from fat) • carb. 30g • pro. 7g
• fat 13g • sat. fat 2g • chol. 57mg • sod. 372mg
• calc. 177mg • fiber 1g

For Mini-Chip Waffles:

Add 1/2 cup mini chocolate morsels to the batter before baking.

CORNMEAL WAFFLES

These waffles taste like cornbread. Drizzle with butter and serve with soup, chili or stew. Also good for brunch or a late night snack served with syrup or cheese sauce.

Makes eight 6-1/2-inch round waffles

1-1/4 cups all-purpose flour
3/4 cup yellow cornmeal
2 tablespoons sugar
1 tablespoon baking powder
1/2 teaspoon salt
1-3/4 cups reduced fat milk
6 tablespoons vegetable oil
2 large eggs

Place ingredients in a large mixing bowl and combine until well blended and smooth. Let batter sit 5 minutes before using. Preheat your Cuisinart® Classic Waffle Maker on setting #3 *(green indicator light will be illuminated when preheated).

Pour 1/2 cup batter onto the center of the lower grid; spread evenly using a heat-proof spatula. Close cover of waffle maker. Indicator light will turn red. When light turns green again, waffle is ready. Open cover and carefully remove baked waffle. Repeat with remaining batter. For best results, serve immediately. However, you may keep waffles warm in a 200°F oven until ready to serve.

* We recommend using setting #3 to achieve a golden brown baked waffle. Adjust the browning control if you prefer lighter or darker waffles.

Nutritional information per waffle:

Calories 264 (43% from fat) • carb. 32g • pro. 6g
• fat 13g • sat. fat 2g • chol. 57mg • sod. 372mg
• calc. 173mg • fiber 1g

NUTTY WHOLE WHEAT WAFFLES

Wholesome wheat flavor combined with crunchy pecans makes a delicious breakfast, brunch or snack. Top with warm fruit compote or syrup.

Makes eight 6-1/2-inch round waffles

1-1/2 cups all-purpose flour
1/2 cup whole wheat flour
2 tablespoons sugar
1 tablespoon baking powder
1/2 teaspoon salt
2 cups reduced fat milk
6 tablespoons vegetable oil
2 large eggs
1/2 cup finely chopped pecans, walnuts, almonds, or hazelnuts

Place ingredients in a large mixing bowl and combine until well blended and smooth. Let batter sit 5 minutes before using. Preheat your Cuisinart® Classic Waffle Maker on setting #3 *(green indicator light will be illuminated when preheated).

Pour 1/2 cup batter onto the center of the lower grid; spread evenly using a heat-proof spatula. Close cover of waffle maker. Indicator light will turn red. When light turns green again, waffle is ready. Open cover and carefully remove baked waffle. Repeat with remaining batter. For best results, serve immediately. However, you may keep waffles warm in a 200°F oven until ready to serve.

* We recommend using setting #3 to achieve a golden brown baked waffle. Adjust the browning control if you prefer lighter or darker waffles.

Nutritional information per waffle:

Calories 263 (44% from fat) • carb. 30g • pro. 7g
• fat 13g • sat. fat 2g • chol. 58mg • sod. 376mg
• calc. 187mg • fiber 1g

FRUITY WAFFLES

Puréed fruit adds lightness and delicate flavor to baked waffles.

Makes eight 6-1/2-inch round waffles

- 2 cups all-purpose flour
- 2 tablespoons sugar
- 1 tablespoon baking powder
- 1/2 teaspoon salt
- 1-3/4 cups reduced fat milk
- 6 tablespoons vegetable oil
- 2 large eggs
- 1/2 cup puréed fruit* or applesauce (use fresh or frozen)

Place ingredients in a large mixing bowl and combine until well blended and smooth. Let batter sit 5 minutes before using. Preheat your Cuisinart® Classic Waffle Maker on setting #3 *(green indicator light will be illuminated when preheated).

Pour a scant 1/2 cup batter onto the center of the lower grid; spread evenly using a heat-proof spatula. Close cover of waffle maker. Indicator light will turn red. When light turns green again, waffle is ready. Open cover and carefully remove baked waffle. Repeat with remaining batter. For best results, serve immediately. However, you may keep waffles warm in a 200°F oven until ready to serve.

* We recommend using setting #3 to achieve a golden brown baked waffle. Adjust the browning control if you prefer lighter or darker waffles.

Nutritional information per waffle:

*Calories 268 (43% from fat) • carb. 32g • pro. 7g
• fat 13g • sat. fat 2g • chol. 57mg • sod. 371mg
• calc. 175mg • fiber 1g*

* May use puréed apricots, peaches, pears, plums, or strawberries.

BANANA CHIP WAFFLES

Sprinkle with powdered sugar for breakfast or top with a scoop of ice cream for an afternoon snack.

Makes eight 6-1/2-inch round waffles

- 2 cups all-purpose flour
- 2 tablespoons sugar
- 1 tablespoon baking powder
- 1/2 teaspoon salt
- 1-2/3 cups reduced fat milk
- 1 medium banana, mashed (1/2 cup)
- 6 tablespoons vegetable oil
- 2 large eggs
- 1/2 cup mini chocolate chips

Place ingredients in a large mixing bowl and combine until well blended and smooth. Let batter sit 5 minutes before using. Preheat your Cuisinart® Classic Waffle Maker on setting #3 *(green indicator light will be illuminated when preheated).

Pour 1/2 cup batter onto the center of the lower grid; spread evenly using a heat-proof spatula. Sprinkle 1 tablespoon of minichips over batter. Allow batter to bubble for 5-10 seconds, then close cover of waffle maker. Indicator light will turn red. When light turns green again, waffle is ready. Open cover and carefully remove baked waffle. Repeat with remaining batter. For best results, serve immediately. However, you may keep waffles warm in a 200°F oven until ready to serve.

* We recommend using setting #3 to achieve a golden brown baked waffle. Adjust the browning control if you prefer lighter or darker waffles.

Nutritional information per waffle:

*Calories 334 (45% from fat) • carb. 39g • pro. 6g
• fat 17g • sat. fat 4g • chol. 57mg • sod. 371mg
• calc. 174mg • fiber 3g*

* For Banana Nut Waffles:

Omit mini chocolate morsels. Add 1/2 cup chopped nuts (walnuts, pecans, almonds) to batter before baking.

CLEANING AND MAINTENANCE

Once you have finished baking, remove plug from electrical outlet. Leave top lid open so grids begin to cool.

Never take your waffle maker apart for cleaning. Simply brush crumbs from grooves, and absorb any excess cooking oil by wiping with a dry cloth or paper towel.

You may clean the grids by wiping with a damp cloth to prevent staining and sticking from batter or oil buildup. **Be certain grids have cooled completely before cleaning.** If batter adheres to plates, simply pour a little cooking oil onto the baked batter and let stand approximately 5 minutes, thus allowing it to soften for easy removal.

To clean exterior, wipe with a soft dry cloth. Never use an abrasive cleanser or harsh pad. **NEVER IMMERSE CORD, PLUG OR UNIT IN WATER OR OTHER LIQUID.**

STORAGE

Store with cord wrapped securely around base. Plug prongs fit into the special grooves on the side of the waffle maker. For compact storage, stand waffle maker on opening end so Cuisinart logo is facing you. The waffle maker has been designed with a special latching feature so the lid stays closed during storage.

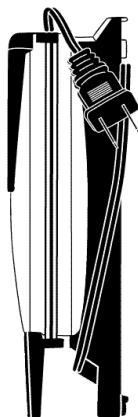

WARRANTY

Limited Three-Year Warranty

This warranty is available to consumers only. You are a consumer if you own a Cuisinart® Classic Waffle Maker which was purchased at retail for personal, family or household use. Except as otherwise required under applicable law, this warranty is not available to retailers or other commercial purchasers or owners.

We warrant that your Cuisinart® Classic Waffle Maker will be free of defects in materials and workmanship under normal home use for 3 years from the date of original purchase.

We suggest you complete and return the enclosed warranty registration card promptly to facilitate verification of the date of original purchase. However, return of the card is not a condition of this warranty.

If your Cuisinart® Classic Waffle Maker should prove to be defective within the warranty period, we will repair (or, if we think necessary, replace) it without charge to you. To obtain warranty service, please call our Customer Service Center toll-free at 1-800-726-0190 or write to: Cuisinart, 150 Milford Road, East Windsor, NJ 08520.

To facilitate the speed and accuracy of your return, enclose \$10.00 for shipping and handling. (California residents need only supply a proof of purchase and should call 1-800-726-0190 for shipping instructions.) Please be sure to include your return address, description of the product's defect, product serial number, and any other information pertinent to the return. Please pay by check or money order.

Your Cuisinart® Classic Waffle Maker has been manufactured to the strictest specifications and has been designed for use only with authorized accessories and replacement parts. This warranty expressly excludes any defects or damages caused by accessories, replacement parts or repair service other than those authorized by Cuisinart.

This warranty does not cover any damage caused by accident, misuse, shipment or other than ordinary household use.

This warranty excludes all incidental or consequential damages. Some states do not allow the exclusion or limitation of these damages, so they may not apply to you.

Cuisinart

SAVOR THE GOOD LIFE™



Coffeemakers



Food Processors



Toaster Ovens



Blenders



Cookware



Ice Cream Makers

Cuisinart offers an extensive assortment of top quality products to make life in the kitchen easier than ever. Try some of our other countertop appliances and cookware, and Savor the Good Life™.

www.cuisinart.com

©2002 Cuisinart
Cuisinart® is a registered
trademark of Cuisinart

150 Milford Road
East Windsor, NJ 08520
Printed in China

02CU13089

IB-4006