



LG

REFRIGERATOR

SERVICE MANUAL

CAUTION
BEFORE SERVICING THE UNIT,
READ THE SAFETY PRECAUTIONS IN THIS MANUAL.

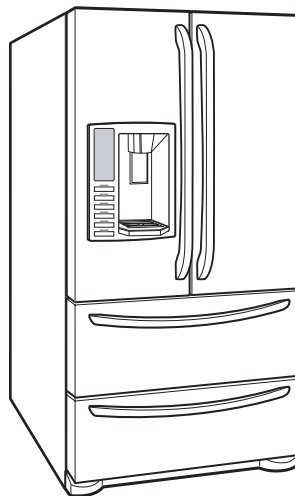

MODEL : LMX25981 / 05**
LMX21981 / 05**

COLOR : STAINLESS(ST)
WESTERN BLACK
SUPER WHITE

CONTENTS

SAFETY PRECAUTIONS	2
1. SPECIFICATIONS	3
2. PARTS IDENTIFICATION	4
3. DISASSEMBLY	5-14
REMOVING AND REPLACING REFRIGERATOR DOORS	5
DOOR INSTALLATION	6
DOOR	7-8
TO REMOVE THE DISPENSER	8
DOOR ALIGNMENT	8
FAN AND FAN MOTOR(Evaporator)	8
ICE FAN SCROLL ASSEMBLY REPLACEMENT	9
DEFROST CONTROL ASSEMBLY	9
LAMP	9
CONTROL BOX-REFRIGERATOR	9
MULTI DUCT	10
MAIN PWB, DISPLAY PWB REPLACEMENT, FUNNEL REPLACEMENT	10
SUB PWB FOR DISPENSER, DUCT DOOR REPLACEMENT, ICE CORNER DOOR REPLACEMENT, ICE MAKER ASSEMBLY	11
AUGER MOTOR COVER, AUGER MOTOR REPLACEMENT	12
DOOR ICE BIN	13
HOW TO REMOVE AND REINSTALL THE PULLOUT DRAWER	14-17
4. ADJUSTMENT	18-19
COMPRESSOR	18
PTC-STARTER	18
OLP(OVERLOAD PROTECTOR)	19
TO REMOVE THE COVER PTC	19
5. CIRCUIT DIAGRAM	20
6. TROUBLESHOOTING	21-25
COMPRESSOR AND ELECTRIC COMPONENTS	21
OTHER ELECTRICAL COMPONENTS	22
SERVICE DIAGNOSIS CHART	23
REFRIGERATION CYCLE	24-25
7. OPERATION PRINCIPLE & REPAIR METHOD OF ICEMAKER	26-28
8. DESCRIPTION OF FUNCTION, CIRCUITS & ERROR CODES	29-45
9. EXPLODED VIEW & REPLACEMENT PARTS LIST	46-

SAFETY PRECAUTIONS

Please read the following instructions before servicing your refrigerator.

1. Unplug the power before handling any electrical components.
2. Check the rated current, voltage, and capacity.
3. Take caution not to get water near any electrical components.
4. Use exact replacement parts.
5. Remove any objects from the top prior to tilting the product.

1. SPECIFICATIONS

21 cu. ft. / 25 cu. ft

ITEMS	SPECIFICATIONS
DOOR DESIGN	Side Rounded
DIMENSIONS (inches)	35 3/4 X 30 1/4 X 69 3/4 (WXDXH) 21cu.ft 35 3/4 X 34 1/4 X 69 3/4 (WXDXH) 25cu.ft
NET WEIGHT (pounds)	302.58 (21cu.ft) 324.18 (25cu.ft)
COOLING SYSTEM	Fan Cooling
TEMPERATURE CONTROL	Micom Control
DEFROSTING SYSTEM	Full Automatic Heater Defrost
DOOR FINISH	Embossed Metal, VCM, Stainless
HANDLE TYPE	Bar
INNER CASE	ABS Resin
INSULATION	Polyurethane Foam

ITEMS	SPECIFICATIONS	
VEGETABLE TRAY	Opaque Drawer Type	
COMPRESSOR	Recipro	
EVAPORATOR	Fin Tube Type	
CONDENSER	Wire Condenser	
REFRIGERANT	R-134a (150 g)	
LUBRICATING OIL	ISO10 (280 ml)	
DEFROSTING DEVICE	SHEATH HEATER	
LAMP	REFRIGERATOR	LED Module(27)
	FREEZER	LED Module(9)

DIMENSIONS

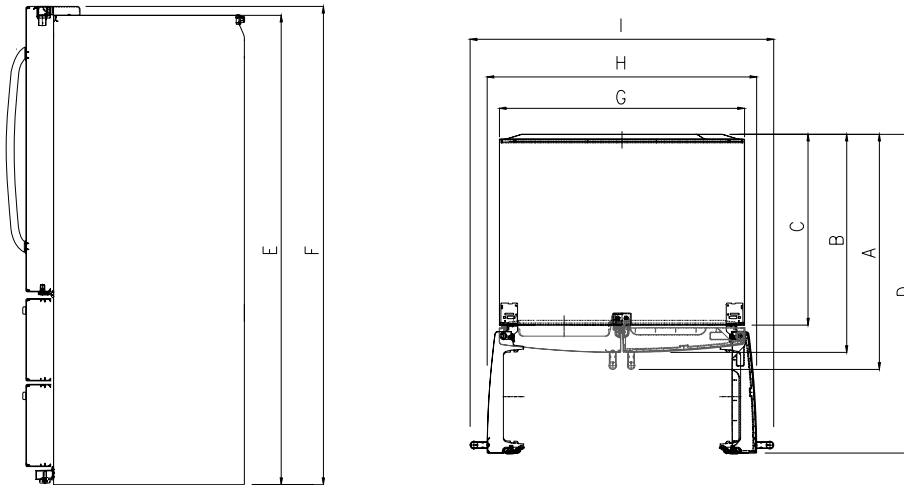

Description		LMX21981** /05	LMX25981** /05
Depth w/ Handles	A	30 in.	34 1/4 in.
Depth w/o Handles	B	27 1/2 in.	31 1/4 in.
Depth w/o Door	C	23 5/8 in.	27 7/8 in.
Depth (Total with Door Open)	D	42 1/4 in.	46 1/2 in.
Height to Top of Case	E	68 3/8 in.	68 3/8 in.
Height to Top of Door Hinge	F	69 3/4 in.	69 3/4 in.
Width	G	35 3/4 in.	35 3/4 in.
Width (door open 90 deg. w/o handle)	H	39 1/4 in.	39 1/4 in.
Width (door open 90 deg. w/ handle)	I	44 1/4 in.	44 1/4 in.

2. PARTS IDENTIFICATION

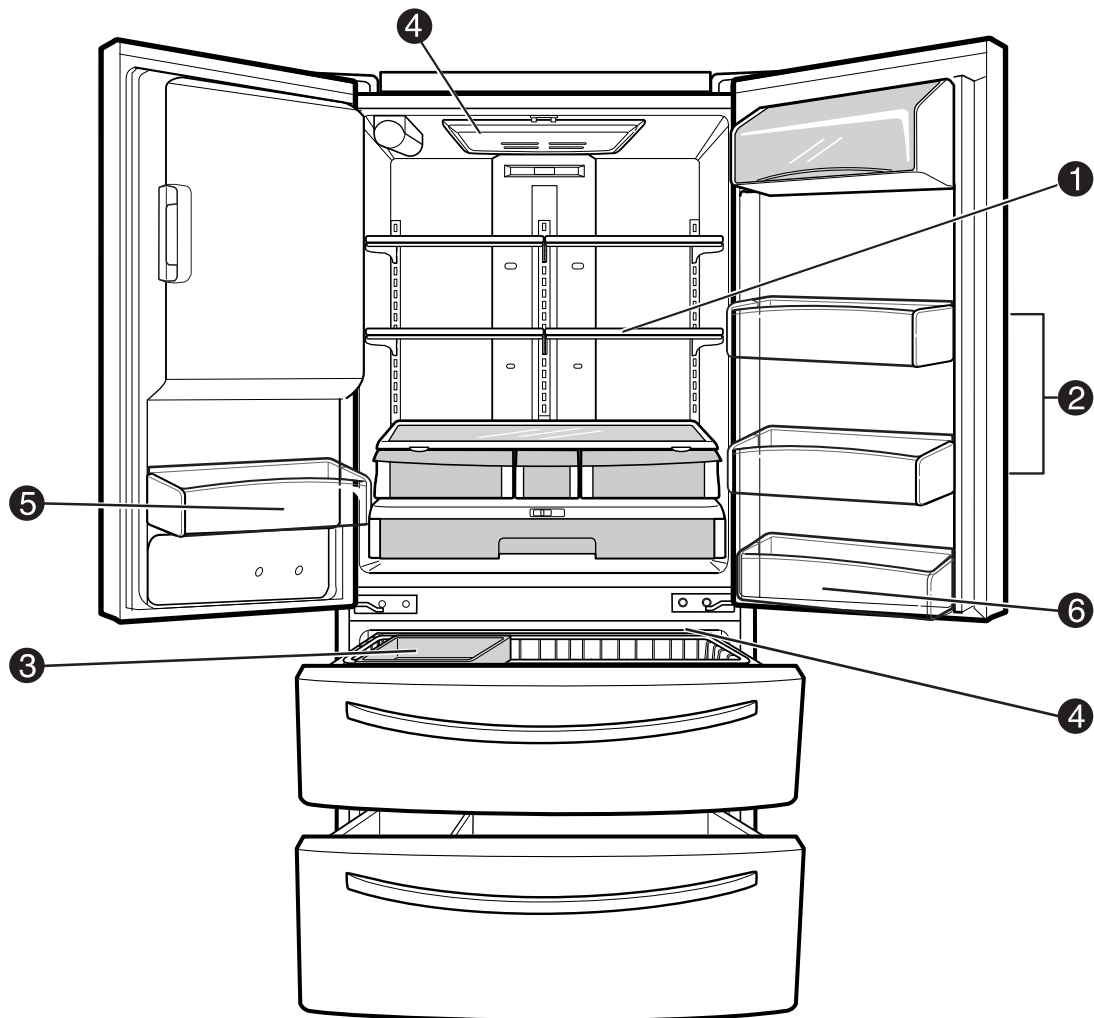

❶ ADJUSTABLE REFRIGERATOR SHELVING

The refrigerator compartment shelves are adjustable to allow flexibility for storage needs.

❷ MODULAR DOOR BINS

Three interchangeable bins can be arranged to suit your storage needs.

❸ REMOVABLE ICE STORAGE BIN

The ice storage bin can be removed to fill ice buckets, coolers, or pitchers.

❹ INTERIOR LAMPS

Two separate LED arrays light the freezer and refrigerator interiors.

❺ FIXED DOOR BIN

❻ FIXED DOOR BIN

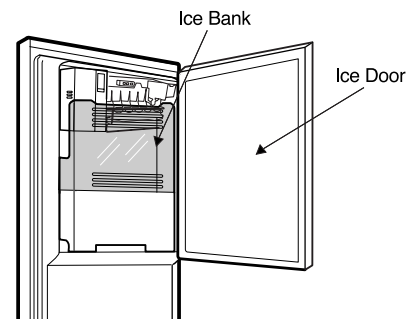

3. DISASSEMBLY

3-1 REMOVING AND REPLACING REFRIGERATOR DOORS

● Removing Refrigerator Door

▲ **CAUTION** : Before you begin, unplug the refrigerator. Remove food and bins from doors.

▶ Left Door -FIG. 2

1. Disconnect water supply tube by pushing back on the disconnect ring (4).-FIG. 1
2. Open door. Loosen top hinge cover screw (1).
- Use flat tip screwdriver to pry back hooks on front underside of cover (2). Lift up cover.
3. Disconnect door switch wire harness. Remove cover.
4. Pull out the tube (3).
5. Disconnect the three wire harnesses (4). Remove the grounding screw (5).
6. Rotate hinge lever (6) counterclockwise. Lift top hinge (7) free of hinge lever latch (8).

▲ **CAUTION** : When lifting hinge free of latch, be careful that door does not fall forward.

7. Place door, inside facing up, down onto a non-scratching surface.

▶ Right Door -FIG. 3

1. Open door. Loosen top hinge cover screw (1). Lift up cover (2).
2. Disconnect door switch wire harness. Remove cover.
3. Disconnect wire harness (3).
4. Remove the grounding screw (4).
5. Rotate hinge lever (5) clockwise. Lift top hinge (6) free of hinge lever latch (7).

▲ **CAUTION** : When lifting hinge free of latch, be careful that door does not fall forward.

6. Lift door up from middle hinge pin door.

7. Place door, inside facing up, down onto a non-scratching surface.

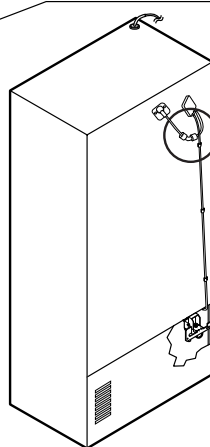
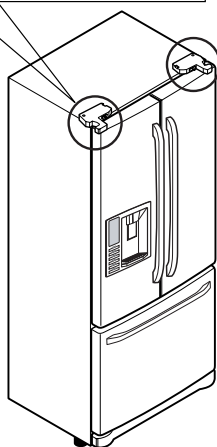
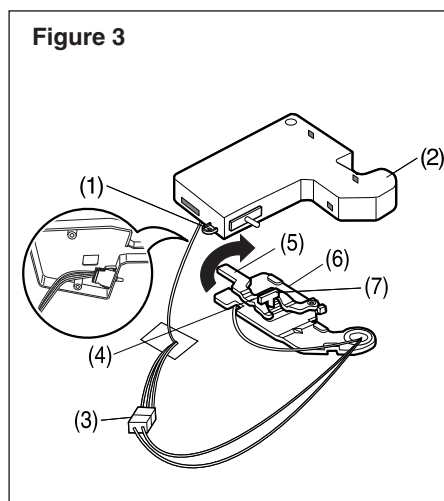
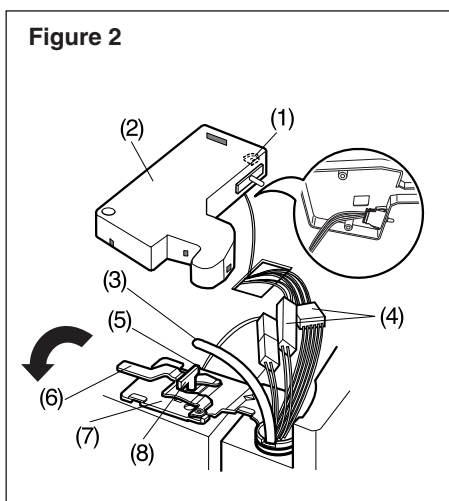
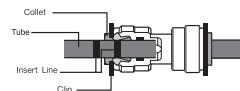
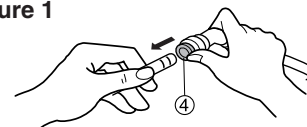
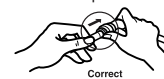

Figure 1



- 1) Insert the tube until you can see only one of the lines printed on the tube.
- 2) After inserting, pull the tube to ascertain that it is secure.
- 3) Assemble clip.



3-2 DOOR

● Door Gasket Removal

1. Remove door frame cover

Starting at top of cover and working down, snap cover out and away from door.

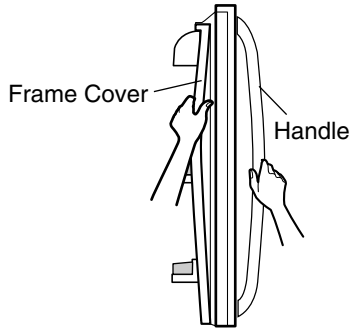

Figure 1

2. Remove gasket bracket clips

There are two clips on each door. Start bracket removal near one of the middle clips.

- 1) Pull gasket back to expose gasket bracket clip and door frame.
- 2) Insert a flat tip screwdriver into seam between gasket bracket and door frame and pry back until clips snap out.
- 3) Continue prying back along seam until all clips snap out.

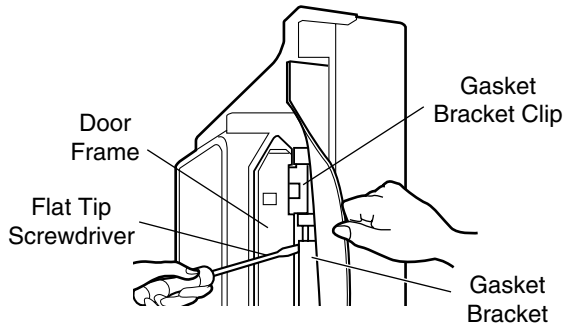

Figure 2

3. Remove gasket

Pull gasket free from gasket channel on the three remaining sides of door.

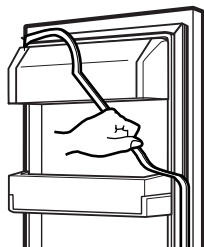

Figure 3

● Door Gasket Replacement

1. Insert gasket bracket clips

- 1) Insert gasket bracket edge beneath door frame edge.
- 2) Turn upper gasket bracket spring so that the spring ends are in the door channel.
- 3) Push in clip until you hear it snap securely into place.

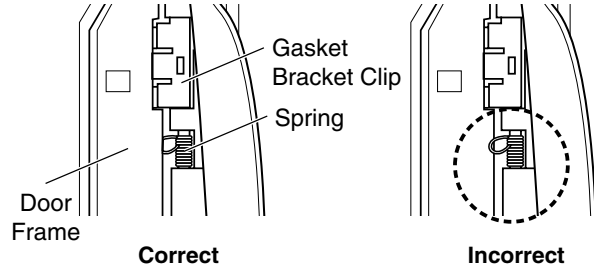

Figure 4

- 4) Push in remaining clip until you hear it snap securely into place.

Note : Make sure that no part of gasket bracket edge protrudes from beneath door frame edge.

2. Insert gasket into channel

- 1) Snap gasket assembly into the door bracket.

<Inserting the Gasket Assembly into the Bracket Door>

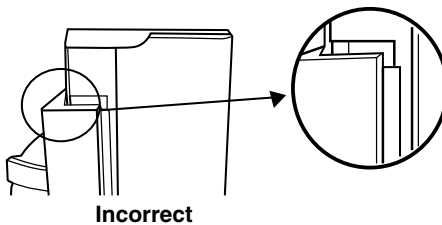
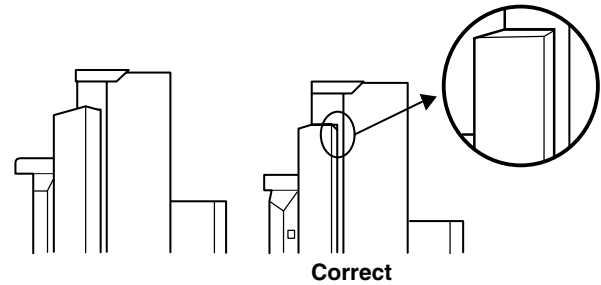

Figure 5

- 2) Press gasket into channels on the three remaining sides of door.

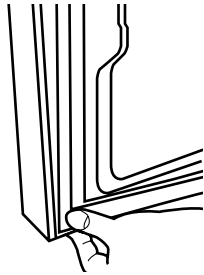

Figure 6

3. Replace door frame cover

Starting at top of cover and working down, snap cover back into door.

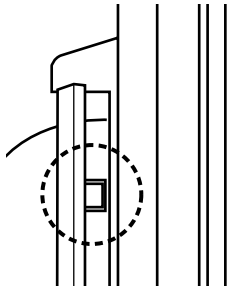

Figure 7

3-3 DOOR ALIGNMENT

If the space between your doors is uneven, follow the instructions below to align the doors:

1. Remove the Base Grillie.
2. Turn the leveling legs (CCW) to raise or (CW) to lower the height of the front of the refrigerator by using flat blade screw driver or 11/32" wrench.
3. Use the wrench (Included with the User Manual) to adjust the bolt in the door hinge to adjust the height. (CCW to raise or CW to lower the height.)

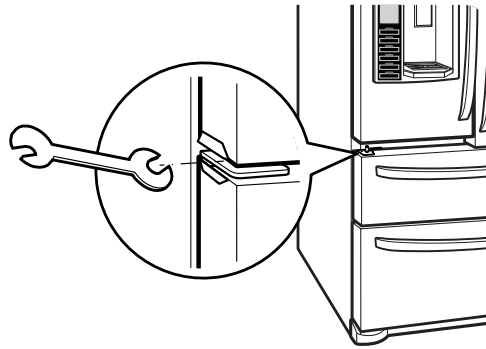

Figure 8

3-4 FAN AND FAN MOTOR(EVAPORATOR)

1. Remove the freezer shelf. (If your refrigerator has an icemaker, remove the icemaker first)
2. Remove the plastic guide for slides on left side by unscrewing phillips head screws.
3. Remove the grille by removing one screw and pulling the grille forward.
4. Remove the Fan Motor assembly by loosening 2 screws and disassembling the shroud.
5. Pull out the fan and separate the Fan Motor and Bracket.

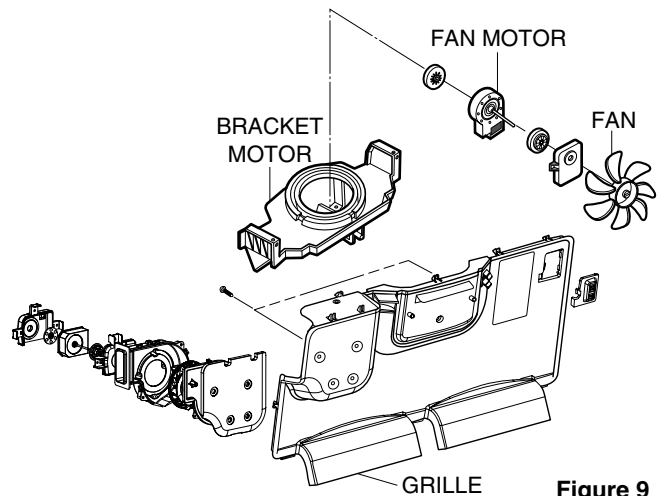
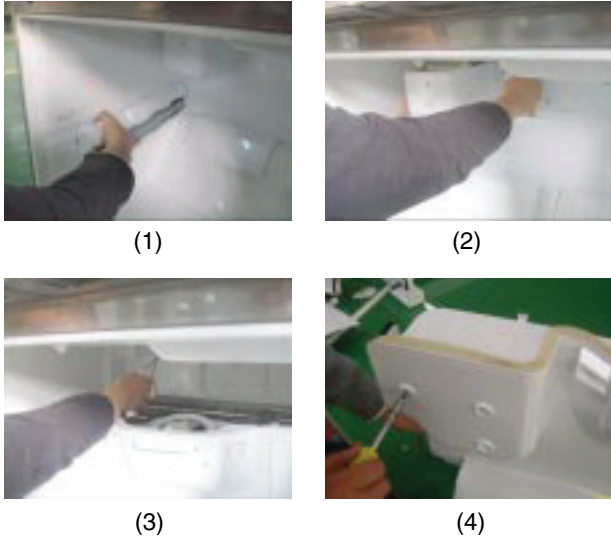

Figure 9

CAUTION
DO NOT ATTEMPT TO REMOVE THE MULLION :
REFRIGERANT LINES!

*** Ice Fan Scroll Assembly Replacement**

- 1) Remove the plastic guide for slides on left side by unscrewing phillips head screws.
- 2) Pull the grille forward as shown in the second picture.
- 3) Disconnect wire harness of the grille.
- 4) Remove the scroll assembly by loosening all screws.



3-5 DEFROST CONTROL ASSEMBLY

Defrost Control assembly consists of Defrost Sensor and FUSE-M.

The Defrost Sensor works to defrost automatically. It is attached to the metal side of the Evaporator and senses its temperature. At 46°F (8°C), it turns the Defrost Heater off. Fuse-M is a safety device for preventing over-heating of the Heater when defrosting.

1. Pull out the grille assembly. (Figure 10)
2. Separate the connector with the Defrost Control assembly and replace the Defrost Control assembly after cutting the Tie Wrap. (Figure 11)

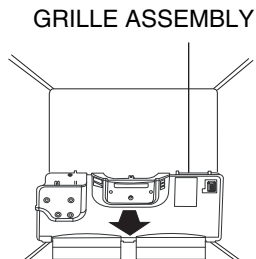

Figure 10

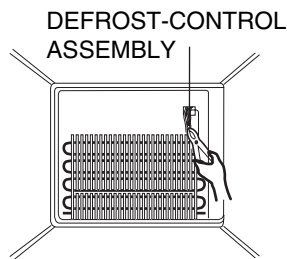

Figure 11

CAUTION
DO NOT ATTEMPT TO REMOVE THE MULLION :
REFRIGERANT LINES!

3-6 LAMP

Unplug Refrigerator, or disconnect power at the circuit breaker.

If necessary, remove top shelf or shelves.

3-6-1 Refrigerator Compartment Lamp

- 1) Release 2 screws.
- 2) Hold both ends with your both hands and pull it downward to remove it.



Figure 12

- 3) Use a flat tool as shown below to remove the cover lamp.



Figure 13

- 4) As shown below, use a flat tool to remove the cover lamp.

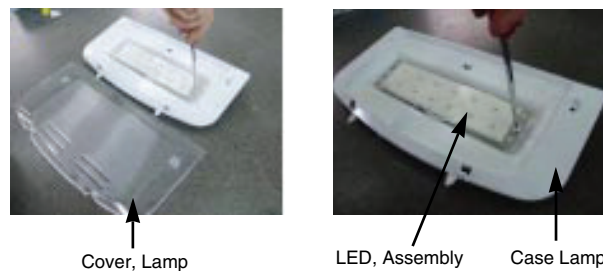

Figure 14

3-6-2 Freezer Compartment Lamp

1. Unplug refrigerator power cord form outlet.
2. Remove screw with driver.
3. Grasp the cover Lamp, pull the cover downward.



Figure 15

3-7 MULTI DUCT

1. Remove the upper and lower Caps by using a flat screwdriver, and remove 2 screws. (Figure 16)
2. Disconnect the lead wire on the bottom position.

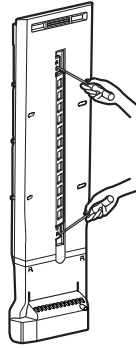
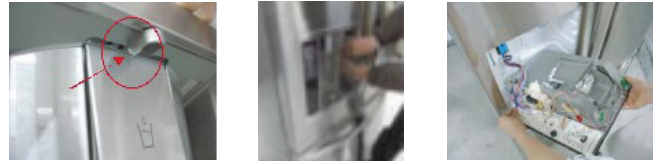

Figure 16



- 3) If nozzle is interfered with button , push and pull out the bottom of button.
- 4) Remove the connected part of Lead wire.

▲ CAUTION : When replacing the dispenser cover in the reverse order of removal, be careful that the lead wire does not come out and the water tube is not pinched by the dispenser,

3-8 MAIN PWB

- 1) Loosen the 3 screws on the PWB cover.



- 2) Remove the PWB cover



- 3) Disconnect wire harness and replace the main PWB in the reverse order of removal.



3-9 DISPENSER



- 1) Pull out the darin



- 2) Hold the inner side of cover dispenser with both hands at the handle side to pull it out forward.

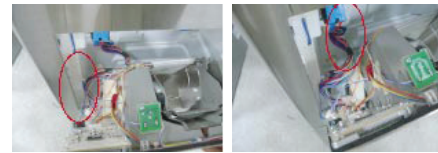

3-10 DISPLAY PCB

As shown below, remove 1 case PCB fixing screw. Remove the display PCB fixing screw.

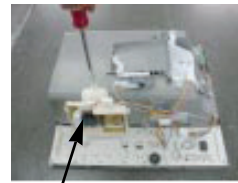

Case, PCB



Display PCB

3-11 ICE BUTTON ASSEMBLY

- 1) Remove the screw fixing the button lever.
- 2) Push the spring from the hanging hook to remove it.
- 3) Apply some pressure to the rib in ① direction and lift the button in ② direction.

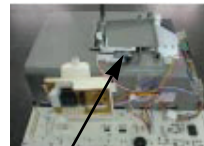

Button Lever



3-12 FUNNEL REPLACEMENT

Pull down and forward.



3-13 WATER BUTTON ASSMEBLY

- 1) Romove screws.
- 2) Grasp the Button assembly and lift up.

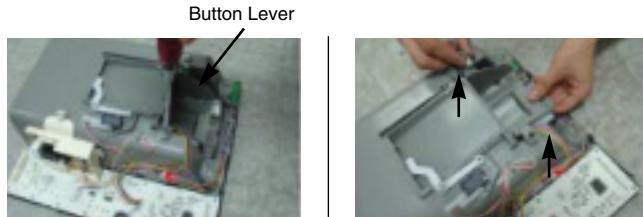

3-14 DUCT DOOR REPLACEMENT

- 1) Pull up and out on the dispenser cover to remove.
- 2) Disconnect the wire harness.
- 3) Remove the funnel
- 4) Replace in reverse order.

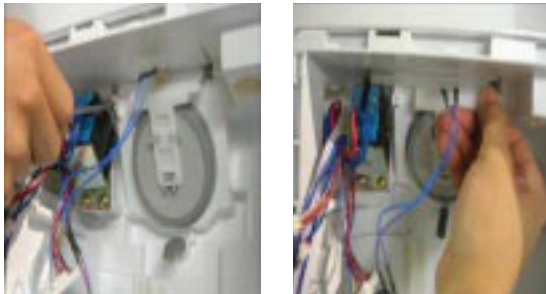

3-15 ICE CORNER DOOR REPLACEMENT

- 1) Loosen the front screw as shown in the picture.
- 2) Lift up the hinge with one hand.
- 3) Pull out the Ice Corner Door with the other hand.



3-16 ICEMAKER ASSEMBLY

- 1) Loosen two screws as shown in the first picture.

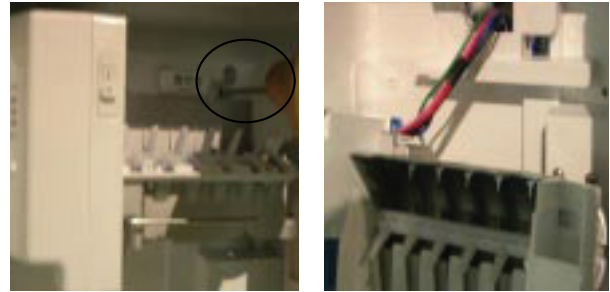

- 2) Disconnect the wire harness & ground screw replace the icemaker assembly in the reverse order of removal.



- 3) It separates a ground connection screw.



3-17 AUGER MOTOR COVER

- 1) After removing the icemaker remove the (5) stainless screws holding the auger motor cover, shown in the pictures below.



- 2) Grip the bottom of motor cover assembly and pull out it.



- 3) Disconnect wire harness of motor cover assembly. There is a auger motor on the back, as shown in the picture.

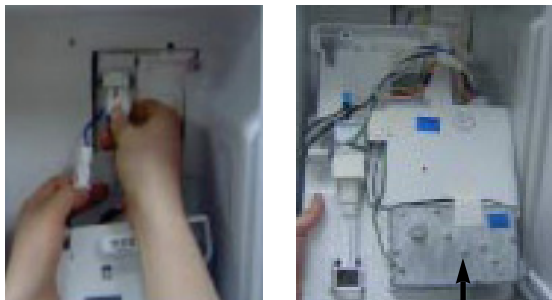

Auger Motor

3-20 HOW TO REMOVE A DOOR ICE BIN

1) Grip the handles, as shown in the picture.

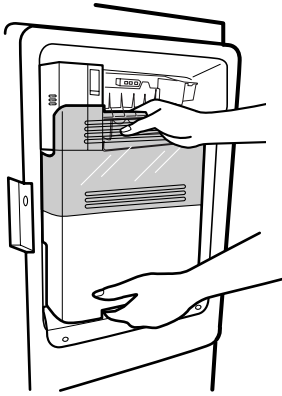

2) Lift the lower part slightly.

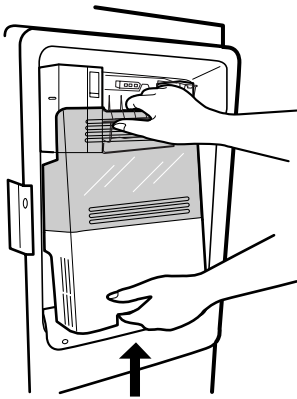

3) Take the Ice Bin out slowly.

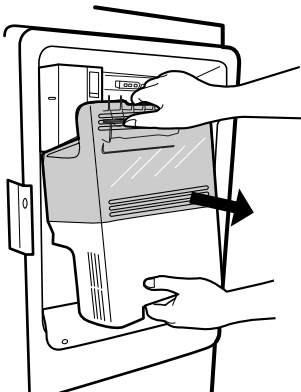

3-21 HOW TO INSERT A DOOR ICE BIN

1) Insert the Ice Bin, slightly tilting it to avoid touching the Icemaker. (especially, ice maker lever)

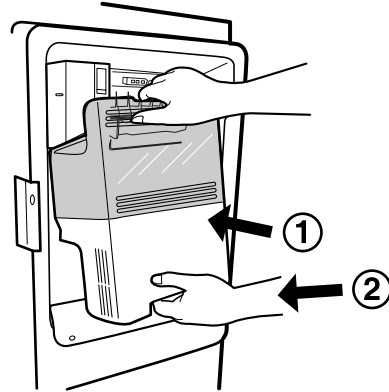

※ Insert the ice bucket carefully avoid contacting the automatic shut off arm.

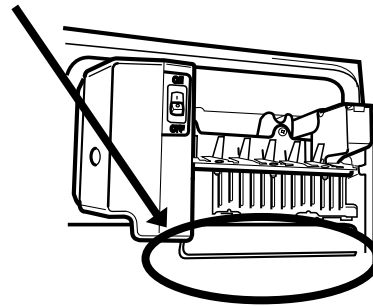

3-22 HOW TO REMOVE AND REINSTALL THE PULLOUT DRAWER

3-22-1 Follow Steps to Remove

Step 1) Open the freezer door.



Step 2) Remove the lower basket.



Step 3) Remove the two screws from the guide rails (one from each side).



Step 4) Lift the freezer door up to unhook it from the rail support and remove. Pull both rails to full extension.



Step 5) First: Remove the gear from the left side first by releasing the tab behind the gear, place a screwdriver between the gear and the tab and pull up on the gear.

Second: Remove the center rail.

Third: Remove the gear from the right side by following the same steps for the left side.

NOTE : THIS TAB MUST BE PUSHED IN TO RELEASE THE GEAR.

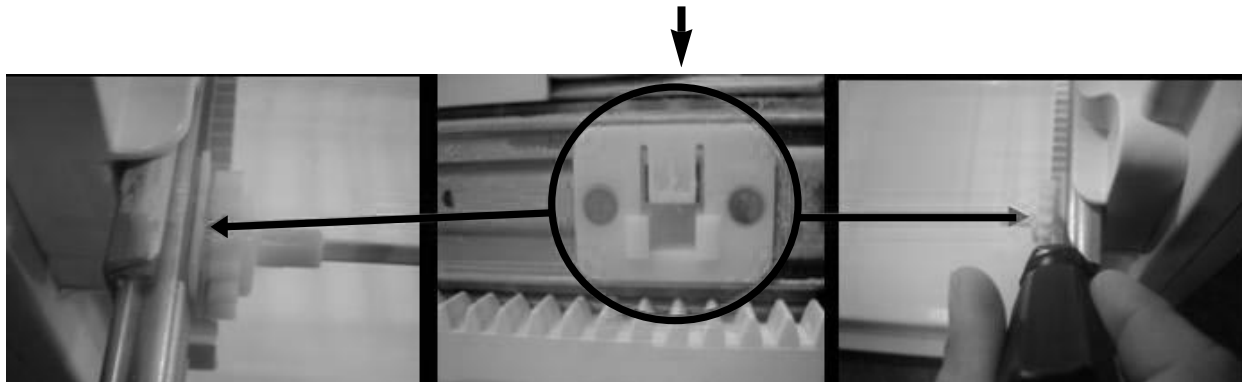

3-22-2 Follow Steps to Reinstall

Step 1) Reinstall the right side gear into the clip.



Step 2) Insert the rail into the right side gear. Gears do **not** need to be perpendicular to each other.



Step 3) Insert the rail into the left side gear, and insert the gear into the clip.



Step 4) The rail system will align itself by pushing the rails all the way into the freezer section. Pull the rails back out to full extension.

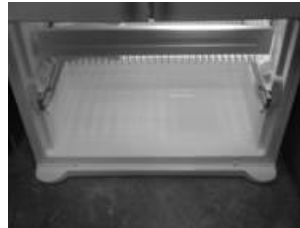

Step 5) Reinstall the freezer door by inserting the rail tabs into the guide rail.



Step 6) Reinstall the two screws into the guide rails (one from each side).

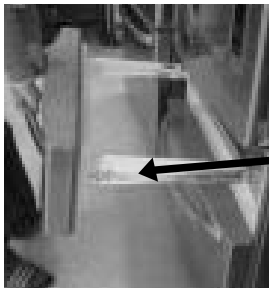

Step 7) Reinstall the lower basket, and close the freezer door.

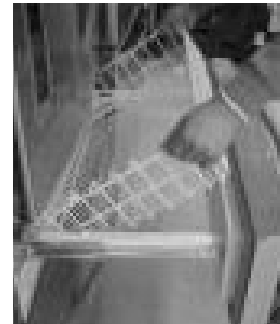

3-23 WATER VALVE DISASSEMBLY METHOD

- 1) Turn off the water. Then separate the water line from the valve.



- 2) Separate the Mechanical Cover and Valve Screw.

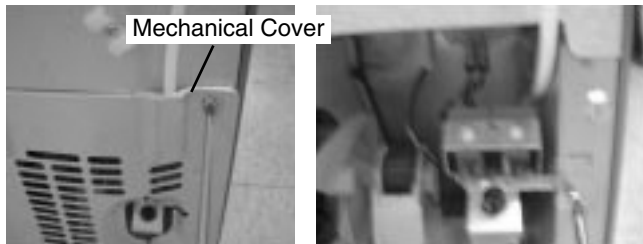

- 3) Separate the housing and pull out the valve.

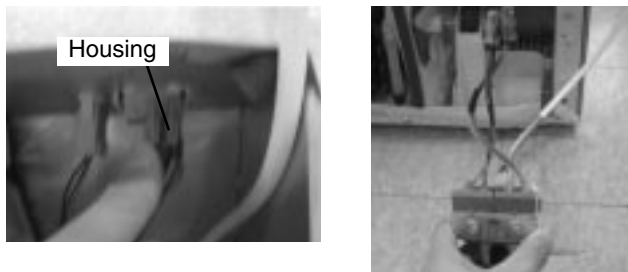

- 4) Lay a dry towel on the floor and get ready to spill water from the water filter. Pull out the Cilp. Then press te collet to separate the tube from the connector and pour out the water until emptied.

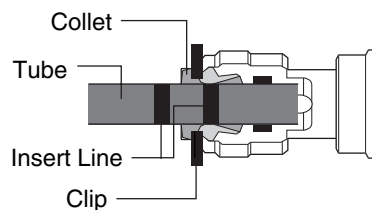

3-24 FAN AND FAN MOTOR DISASSEMBLY METHOD

- 1) Using a short screwdriver, loosen one SCREW in DRAIN PIPE ASSEMBLY and one connected to the MOTOR COVER.

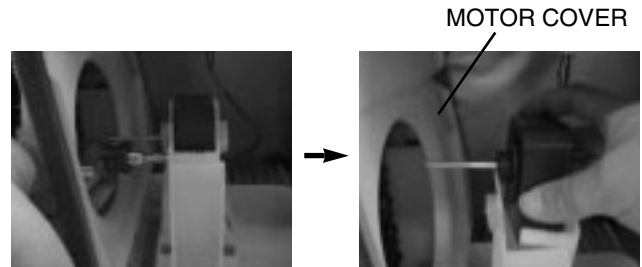

- 2) Pull and separate the FAN ASSEMBLY and MOTOR turning counterclockwise based on the MOTOR SHAFT.

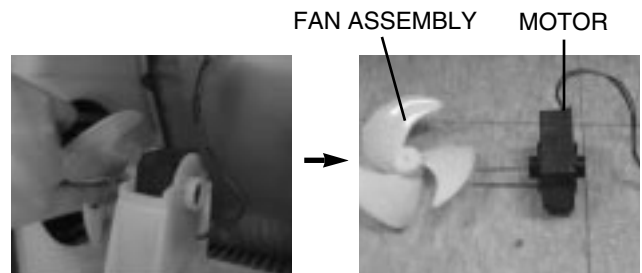

The assembly is in the reverse order of the disassembly and take special care for the following details.

1. Be careful not to bend the tube during assembly.
2. Press the WATER DISPENSER button until water pours out and check for leakage in the CONNECTOR TUBE (It differs by the water pressure but usually takes about 2 minutes until water pours out.)

3-25 TOP DRAWER

To remove the freezer drawer, pull the drawer open to full extension. Remove the drawer and Ice Bin lifting the basket from the rail system.

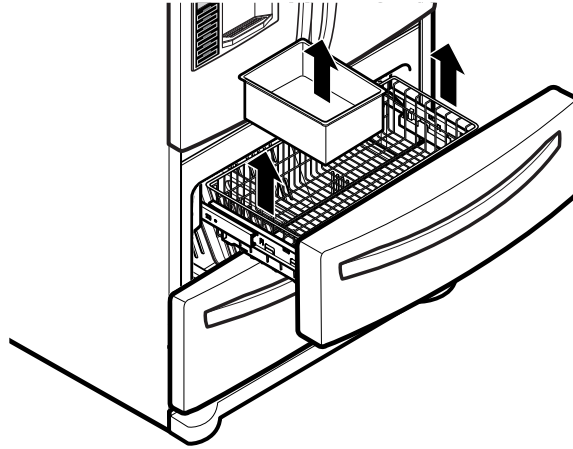

3-26 BOTTOM DRAWER

To remove the freezer drawer, pull the drawer open to full extension. Remove the lower DuraBase® basket by lifting the basket from the rail system.

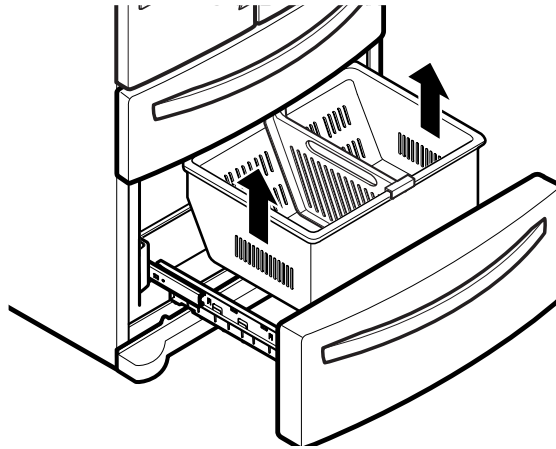

4. ADJUSTMENT

4-1 COMPRESSOR

4-1-1 Role

The compressor intakes low temperature and low pressure gas from the evaporator of the refrigerator and compresses this gas to high-temperature and high-pressure gas. It then delivers the gas to the condenser.

4-1-2 Composition

The compressor includes overload protection. The PTC starter and OLP (overload protector) are attached to the outside of the compressor. Since the compressor is manufactured to tolerances of 1 micron and is hermetically sealed in a dust and moisture-free environment, use extreme caution when performing repairs.

4-1-3 Note for usage

- (1) Be careful not to allow over-voltage and over-current.
- (2) If compressor is dropped or handled carelessly, poor operation and noise may result.
- (3) Use proper electric components appropriate to the particular compressor in your product.
- (4) Keep the compressor dry. If the Compressor gets wet (in the rain or a damp environment) and rust forms in the pin of the Hermetic Terminal, poor operation and contact may result.
- (5) When replacing the compressor, be careful that dust, humidity, and soldering flux don't contaminate the inside of the compressor. Dust, humidity, and solder flux may contaminate the cylinder and may cause noise, improper operation, or even lock up.

4-3 Over Load Protector (OLP)

1. Define

- (1) The OLP (OVERLOAD PROTECTOR) is attached to the Compressor and protects the motor by opening the circuit to the motor if the temperature rises and activating the bimetal spring in the OLP.
- (2) When high current flows to the compressor motor, the Bimetal works by heating the heater inside the OLP, and the OLP protects the Motor by cutting off the current flowing to the Compressor Motor.

2. Role

- (1) The OLP is attached to the sealed compressor used for the refrigerator. It prevents the motor coil from being started in the compressor.
- (2) For normal operation of the OLP, do not turn the adjustment screw of the OLP in any way.

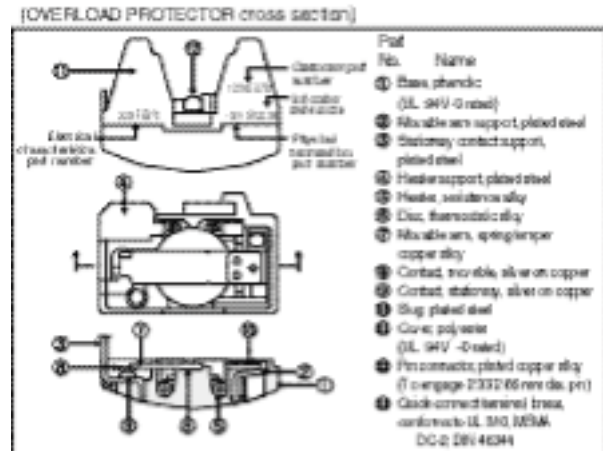

5. CIRCUIT DIAGRAM

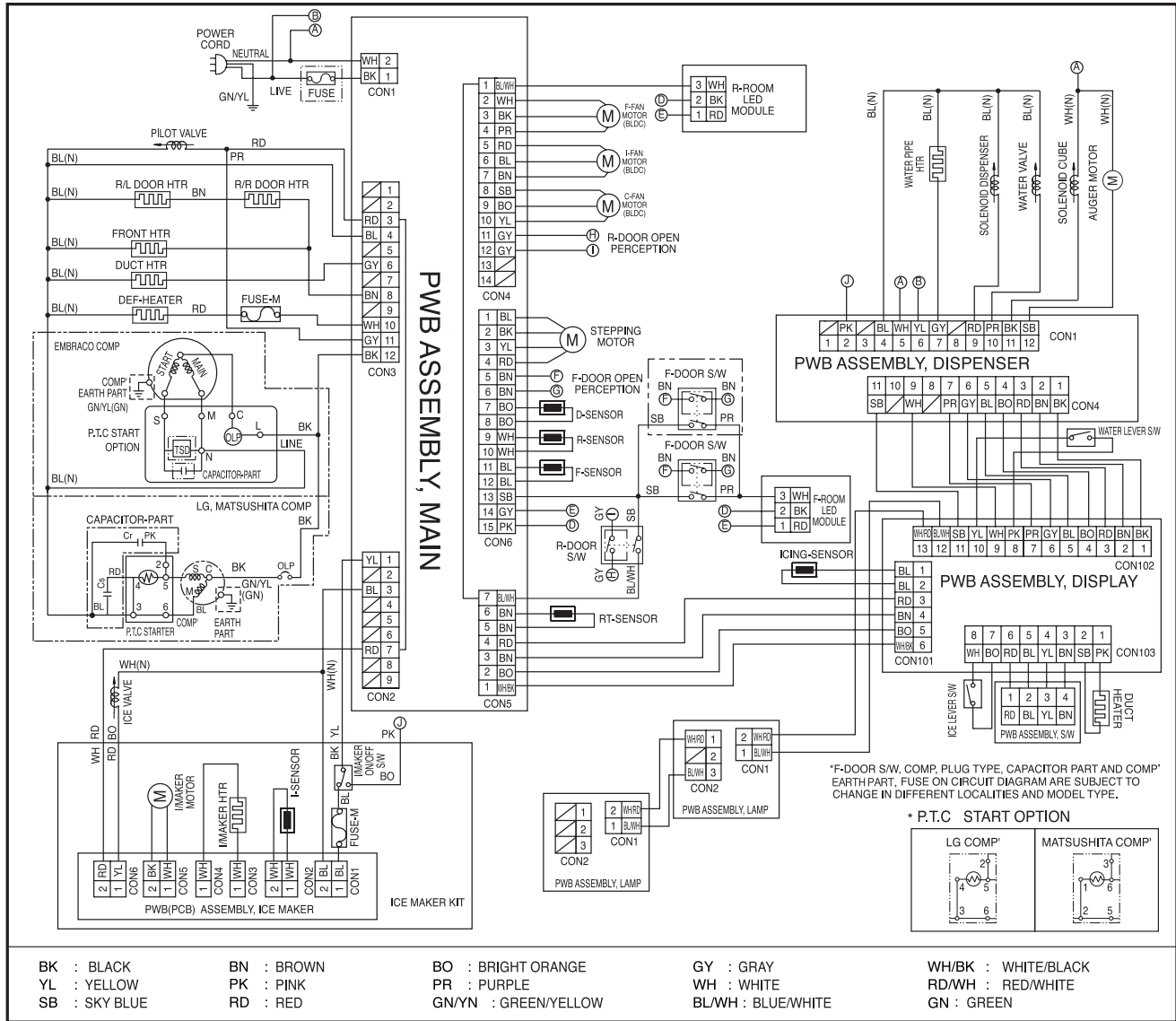

6. TROUBLESHOOTING

6-1 COMPRESSOR AND ELECTRIC COMPONENTS

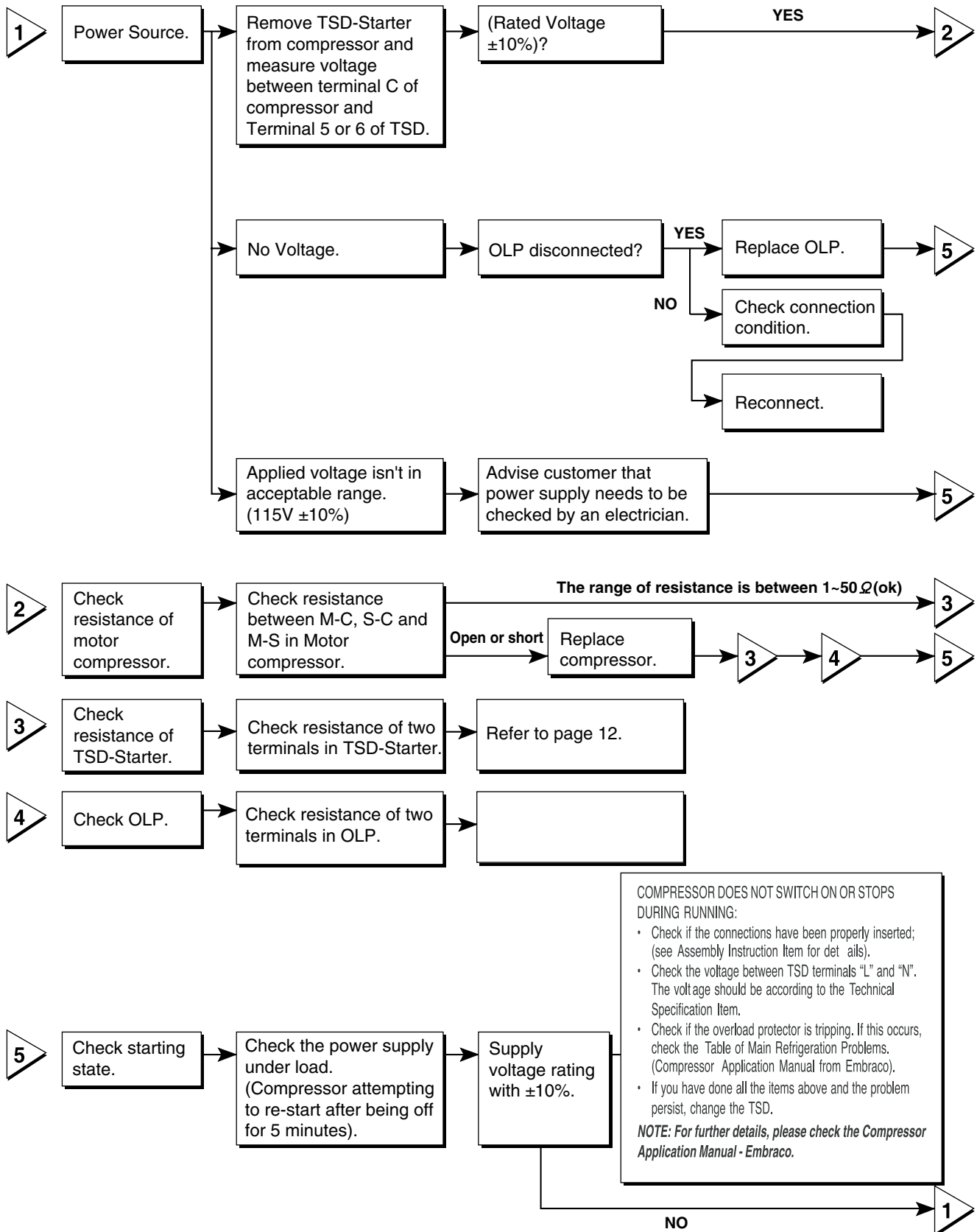

6-2 TSD AND OLP

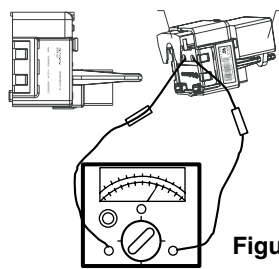
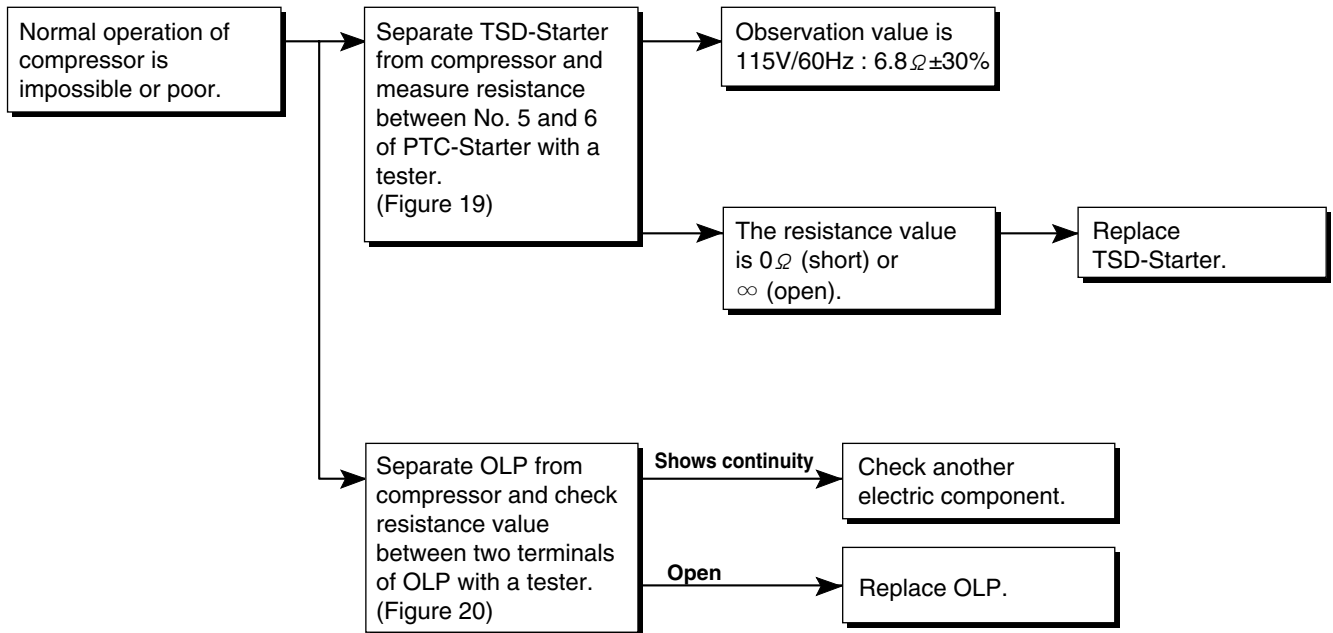

Figure 19

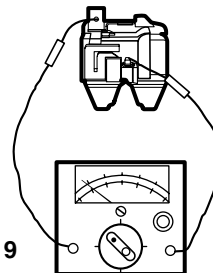
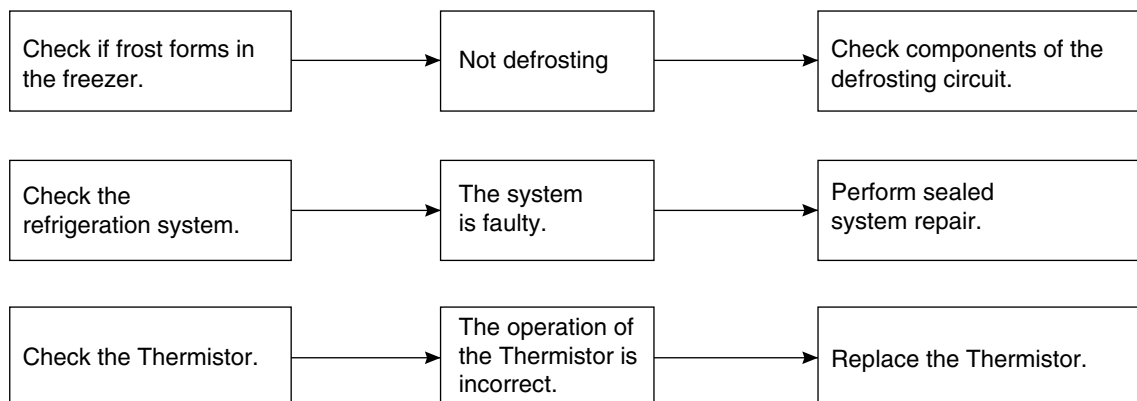

Figure 20

6-3 SERVICE DIAGNOSIS CHART

COMPLAINT	POINTS TO BE CHECKED	REMEDY
No Cooling.	<ul style="list-style-type: none"> Is the power cord unplugged from the outlet? Check if the power switch is set to OFF. Check if the fuse of the power switch is shorted. Measure the voltage of the power outlet. 	<ul style="list-style-type: none"> Plug into the outlet. Set the switch to ON. Replace the fuse. If the voltage is low, correct the wiring.
Cools poorly.	<ul style="list-style-type: none"> Check if the unit is placed too close to the wall. Check if the unit is placed too close to the stove, gas cooker, or in direct sunlight. Is the ambient temperature too high or the room door closed? Check if food put in the refrigerator is hot. Did you open the door of the unit too often or check if the door is sealed properly? Check if the Control is set to Warm position. 	<ul style="list-style-type: none"> Place the unit about 4 inches (10cm) from the wall. Place the unit away from these heat sources. Lower the ambient temperature. Put in foods after they have cooled down. Don't open the door too often and close it firmly. Set the control to Recommended position.
Food in the Refrigerator is frozen.	<ul style="list-style-type: none"> Is food placed in the cooling air outlet? Check if the control is set to colder position. Is the ambient temperature below 41°F(5°C)? 	<ul style="list-style-type: none"> Place foods in the high-temperature section (front part) Set the control to Recommended position. Set the control to Warm position.
Condensation or ice forms inside the unit.	<ul style="list-style-type: none"> Is liquid food sealed? Check if food put in the refrigerator is hot. Did you open the door of the unit too often or check if the door is sealed properly? 	<ul style="list-style-type: none"> Seal liquid foods with wrap. Put in foods after they have cooled down. Don't open the door too often and close it firmly.
Condensation forms in the Exterior Case.	<ul style="list-style-type: none"> Check if the ambient temperature and humidity of the surrounding air are high. Is there a gap in the door gasket? 	<ul style="list-style-type: none"> Wipe moisture with a dry cloth. It will disappear in low temperature and humidity. Fill up the gap.
There is abnormal noise.	<ul style="list-style-type: none"> Is the unit positioned in a firm and even place? Are any unnecessary objects placed in the back side of the unit? Check if the Drip Tray is not firmly fixed. Check if the cover of the compressor enclosure in the lower front side is taken out. 	<ul style="list-style-type: none"> Adjust the Leveling Screw, and position the refrigerator in a firm place. Remove the objects. Fix the Drip Tray firmly in the original position. Place the cover in its original position.
Door does not close well.	<ul style="list-style-type: none"> Check if the door gasket is dirty with an item like juice. Is the refrigerator level? Is there too much food in the refrigerator? 	<ul style="list-style-type: none"> Clean the door gasket. Position in a firm place and level the Leveling Screw. Make sure food stored in shelves does not prevent the door from closing.
Ice and foods smell unpleasant.	<ul style="list-style-type: none"> Check if the inside of the unit is dirty. Are foods with a strong odor unwrapped? The unit smells of plastic. 	<ul style="list-style-type: none"> Clean the inside of the unit. Wrap foods that have a strong odor. New products smell of plastic, but this will go away after 1-2 weeks.

● Other possible problems :



6-4 REFRIGERATION CYCLE

▼ Troubleshooting Chart

CAUSE		STATE OF THE UNIT	STATE OF THE EVAPORATOR	TEMPERATURE OF THE COMPRESSOR	REMARKS
LEAKAGE	PARTIAL LEAKAGE	Freezer compartment and Refrigerator don't cool normally.	Low flowing sound of refrigerant is heard and frost forms in inlet only.	A little higher than ambient temperature.	<ul style="list-style-type: none"> Refrigerant level is low due to a leak. Normal cooling is possible by restoring the normal amount of refrigerant and repairing the leak.
	COMPLETE LEAKAGE	Freezer compartment and Refrigerator don't cool normally.	Flowing sound of refrigerant is not heard and frost isn't formed.	Equal to ambient temperature.	<ul style="list-style-type: none"> No discharging of refrigerant. Normal cooling is possible by restoring the normal amount of refrigerant and repairing the leak.
CLOGGED BY DUST	PARTIAL CLOG	Freezer compartment and Refrigerator don't cool normally.	Flowing sound of refrigerant is heard and frost forms in inlet only.	A little higher than ambient temperature.	<ul style="list-style-type: none"> Normal discharging of the refrigerant. The capillary tube is faulty.
	WHOLE CLOG	Freezer compartment and Refrigerator don't cool.	Flowing sound of refrigerant is not heard and frost isn't formed.	Equal to ambient temperature.	<ul style="list-style-type: none"> Normal discharging of the refrigerant.
MOISTURE CLOG		Cooling operation stops periodically.	Flowing sound of refrigerant is not heard and frost melts.	Lower than ambient temperature.	<ul style="list-style-type: none"> Cooling operation restarts when heating the inlet of the capillary tube.
DEFECTIVE COMPRESSION	COMP-RESSION	Freezer and Refrigerator don't cool.	Low flowing sound of refrigerant is heard and frost forms in inlet only.	A little higher than ambient temperature.	<ul style="list-style-type: none"> Low pressure at high side of compressor due to low refrigerant level.
	NO COMP-RESSION	No compressing operation.	Flowing sound of refrigerant is not heard and there is no frost.	Equal to ambient temperature.	<ul style="list-style-type: none"> No pressure in the high pressure part of the compressor.

6-4-1 Cleaning

There is no need for routine condenser cleaning in normal Home operating environments. If the environment is particularly greasy or dusty, or there is significant pet traffic in the home, the condenser should be cleaned every 2 to 3 months to ensure maximum efficiency.

If you need to clean the condenser:

- Remove the mechanical cover.
- Use a vacuum cleaner with a soft brush to clean the grille, the open areas behind the grille and the front surface area of the condenser.
- Replace the mechanical cover.

6-4-2 SEALED SYSTEM DIAGNOSIS

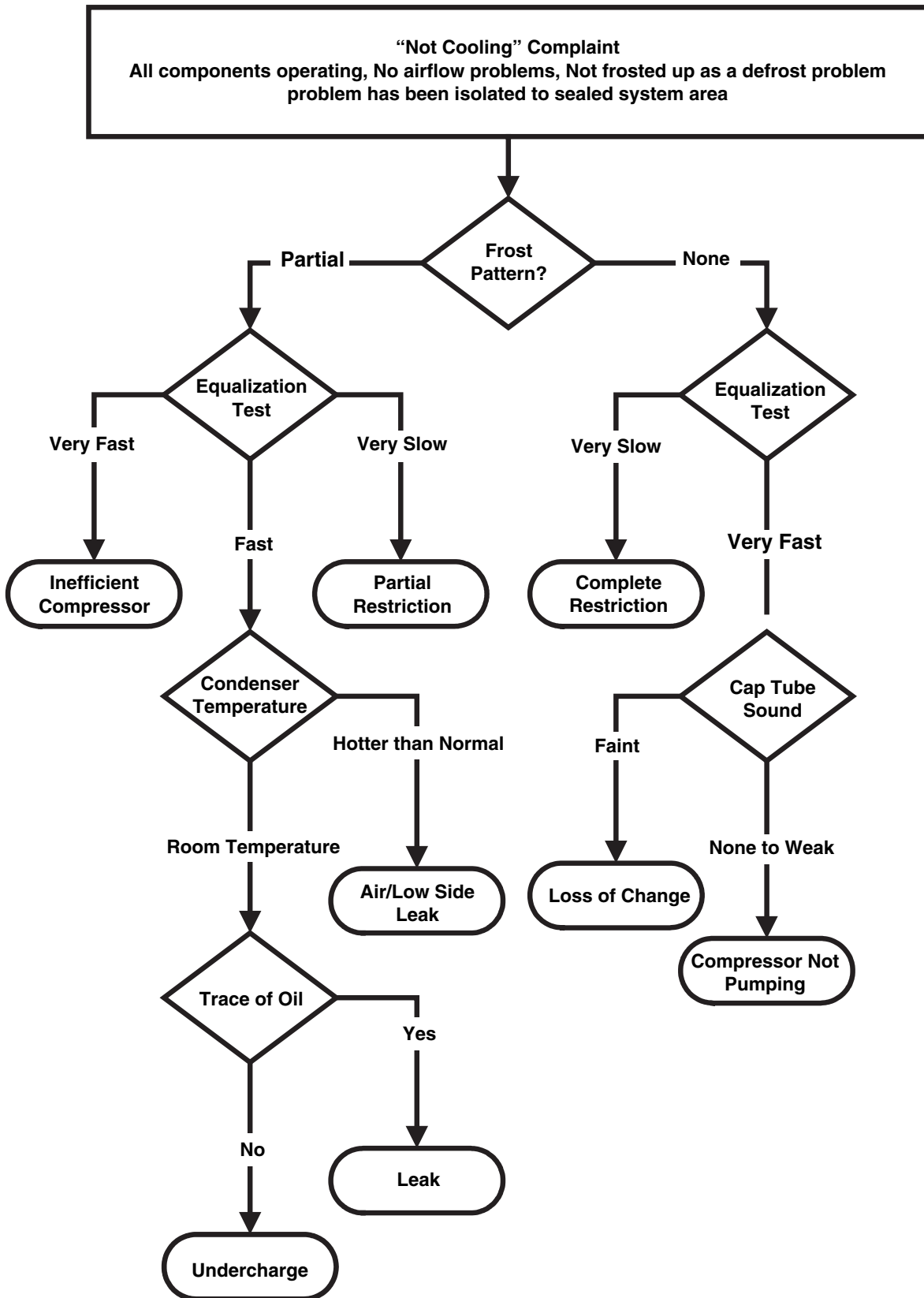

(The equalization test is trying to restart a compressor using a start kit after it has been operating.)

7. OPERATION PRINCIPLE AND REPAIR METHOD OF ICEMAKER

7-1 OPERATION PRINCIPLE

7-1-1 Operation Principle of IceMaker

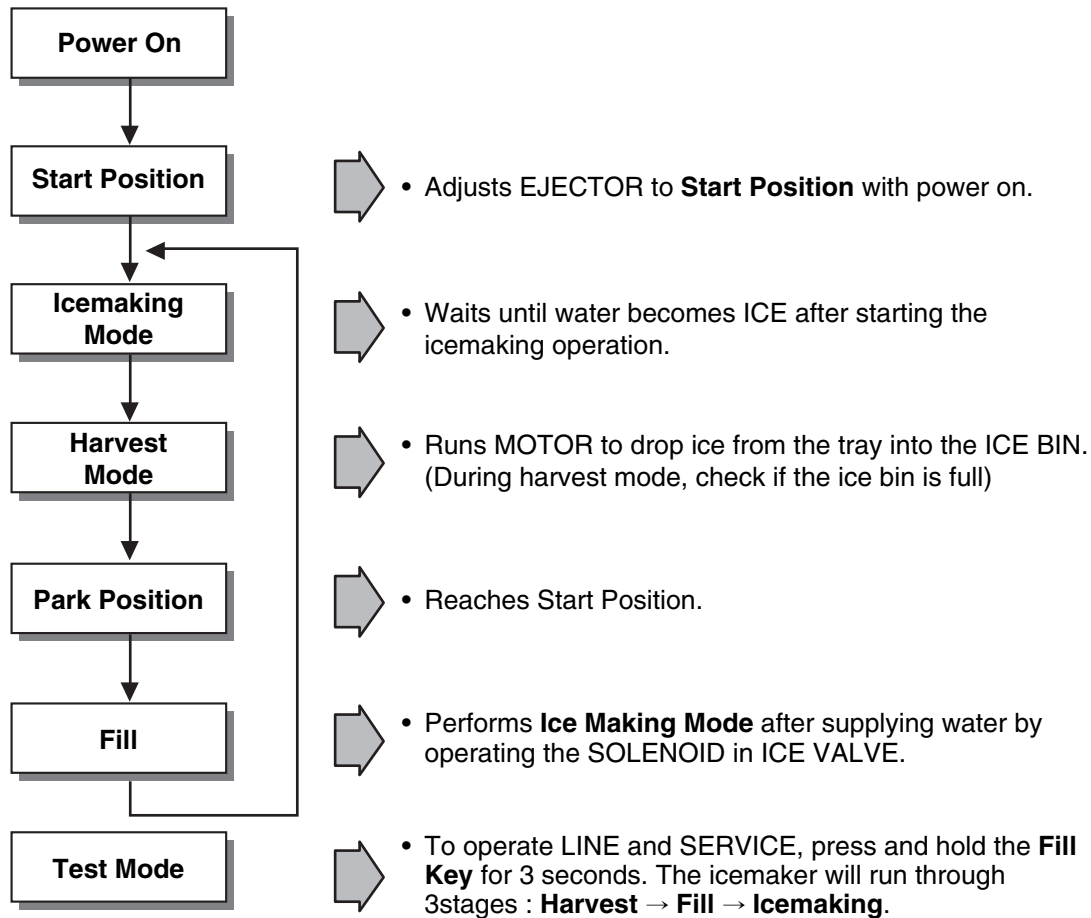

1. Turning the Icemaker stop switch off (O) stops the ice making function.
2. Setting the Icemaker switch to OFF and then turning it back on will reset the icemaker control.

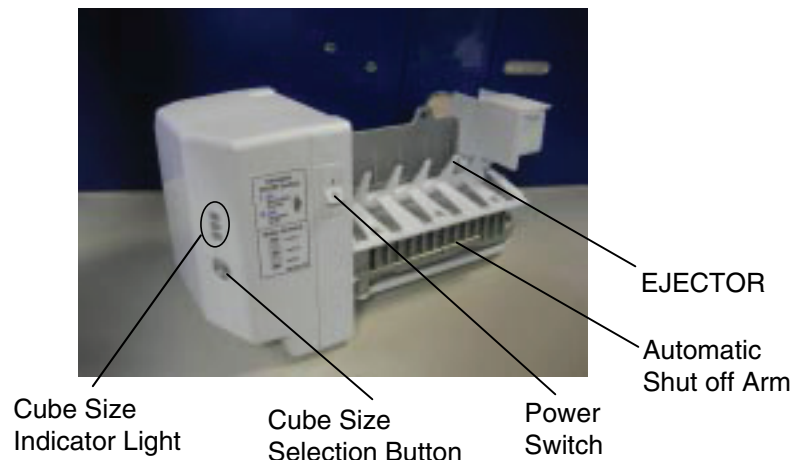

7-2 ICE MAKER FUNCTIONS

7-2-1 Icemaking Mode

1. Icemaking refers to the freezing of supplied water in the ice tray. Complete freezing is assured by measuring the temperature of the Tray with Icemaking SENSOR.
2. Icemaking starts after completion of the water fill operation.
3. The Ice Making function is completed when the sensor reaches 19°F (-7°C), 55 minutes after starting.

NOTE : After Icemaker Power is ON, the Icemaker heater will be on for test for 6 sec.



7-2-2 Harvest Mode

1. Harvest (Ice removing) refers to the operation of dropping ices into the ice bin from the tray when icemaking has completed.
 2. Harvest mode:
 - (1)The Heater is ON for 30 seconds, then the motor starts.
 - (2)The feeler arm senses the quantity of ice in the ice storage bin while rotating with the EJECTOR.
 - A. Ice storage bin is full : The EJECTOR stops (heater off).
 - B. Ice storage bin is not full : The EJECTOR rotates twice to open for ice.
- ※ If the EJECTOR does not rotate once within 5 minutes in B mode, separate heater control mode starts operating to prevent the EJECTOR from being constrained. (It is recommended that the user open for ice to return to normal mode.)

7-2-3 Fill/Park Position

1. Once a normal harvest mode has been completed, the water solenoid will be activated.
2. The amount of water is adjusted by pressing the Fill Key repeatedly. This changes the time allowed for fill as illustrated in the table below.





Water supply amount TABLE

STAGE	TIME TO SUPPLY	INDICATIONS	REMARKS
1	5 sec.		The water amount will vary depending on the water control Switch setting, as well as the water pressure of the connected water line.
2	5.5 sec. (FIRST STAGE)		
3	6 sec.		

7-2-4 Function TEST

1. This is a forced operation for TEST, Service, cleaning, etc. It is operated by pressing and holding the Fill Key for 3 seconds.
2. The test works only in the Icemaking Mode. It cannot be entered from the Harvest or Fill mode.
3. **Caution!** If the test is performed before water in the icemaker is frozen, the ejector will pass through the water. When the Fill mode begins (Stage 4), unless the water supply has been shut off, added water will overflow into the ice bin. If the control doesn't operate normally in the TEST mode, check and repair as needed.
4. After water is supplied, the normal CYCLE is followed : **icemaking** → **Harvest** → **Park Position** → **Fill**.
5. Five seconds after Stage 5 is completed, the Ice Maker returns to MICOM control. The time needed to supply water resets to the pre- test setting.

Diagnosis TABLE

STAGE	ITEMS	INDICATOR	REMARKS
1	HEATER		Five seconds after heater starts, a heater will go off if the temperature by sensor is higher than 10°C
2	MOTOR		Five seconds after heater starts, you can confirm that a motor is moving.
3	HALL IC I		Check if Ice Bin is full or not. If Ice bin is full, the motor and heater are off and on stand by until Ice bin is empty.
4	HALL IC II		You can confirm HALL IC detection of start position.
5	VALVE		Two seconds after detection of start position, you can confirm that valve is on.
6	Reset	Return to Status prior to TEST MODE	Five seconds after fifth stage is completed, The icemaker resets to initial status.

7-3 DEFECT DIAGNOSIS FUNCTION

7-3-1 ERROR CODES shown on Ice Maker water supply control panel

NO	DIVISION	INDICATOR	CONTENTS	REMARKS
1	Normal	Mark time to supply	None	Display switch operates properly
2	Icemaking Sensor malfunction		Open or short-circuited wire	Make sure that the wire on each sensor is connected.

8. DESCRIPTION OF FUNCTION & CIRCUIT OF MICOM

8-1 FUNCTION

8-1-1 Function

1. When the appliance is plugged in, it is set to 37°F for Refrigerator and 0°F for freezer.
You can adjust the Refrigerator and the Freezer control temperature by pressing the ADJUST button.
2. When the power is initially applied or restored after a power failure, it is set to Control temperature Previously.

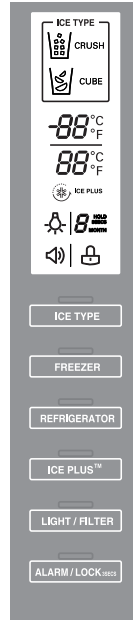

8-1-2 How to Toggle the Display between °F & °C

1. The initial setting is °F and the display temperature mode can be changed from °F to °C or °C to °F by pressing and holding the FRZ TEMP and the REF TEMP keys at the same time for over 5 seconds.

8-1-3 Lock function (dispenser and display button lock)

1. When the refrigerator is first turned on, the buttons are not locked. "LOCK" is deactivated with no light on.
2. To lock the display, the dispenser, and the control panel, press and hold the LOCK button for 3 seconds. "LOCK" is activated with light off.
3. The LOCK button is the only control feature that remains active in the locked state. The buzzer sound, other control buttons, and the dispenser are deactivated.
4. To release from the locked state, press and hold the LOCK button again for 3 seconds.

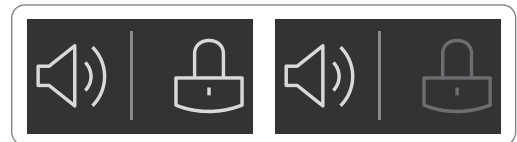

Ex) In selecting "LOCK"

Ex) In selecting "LOCK" again

8-1-4 Filter condition display function

1. There is a replacement indicator light for the filter cartridge on the dispenser.
2. Water filter needs replacement once six months or of using water filter.
3. When the Water Filter Icon is turn on, you must exchange the filter.
4. After replacing the filter, press and hold the Light/Filter button for more than 3 seconds.
After then water Filter icon turn off with reset status.

Classification	In initial Power On / Filter RESET	Light On
	Filter Status Display	

8-1-5 Ice Plus selection

Please select this function for quick freezing.

- When you press the Ice Plus Button, the Ice Plus ICON will be turned on again.
- Ice Plus function automatically turns off after a fixed time passes.



8-1-6 Dispenser use selection

You can select water or ice by separated pad switch.

- When you press ice type button, ice type will be changed. (Crush or Cube)
- Hold your cup in the dispenser for a few seconds after dispensing ice or water to allow the last pieces of ice drops or water to fall into the cup.
- When after initially establishing the water comes out, the water tank inside fills and until at the time of quality the hour is caught.

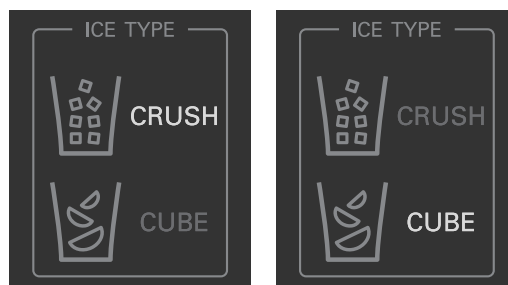

8-1-7 CONTROL OF FREEZER FAN MOTOR

1. Freezer fan motor has high and standard speeds.
2. High speed is used at power-up, for Ice Plus, and when refrigerator is overloaded. Standard speeds is used for general purposes.
3. To improve cooling speed, the RPM of the freezer fan motor change from normal speed to high.
4. High speed (2700RPM) : Initial power on or load corresponding operation, Ice Plus
Normal speed (2400RPM) : General working conditions.
5. Fan motor stops when refrigerator or freezer door opens.

8-1-8 Cooling Fan Motor

1. The cooling fan is switched ON and OFF in conjunction with the compressor.
2. The cooling fan runs at a single speed.
3. The Failure sensing method is the same as in the fan motor of the freezing fan motor(refer to failure diagnosis function table for failure display).

8-1-9 Icing Fan

1. The Icing Fan is controlled by the the sensor on the top of the ice room.
2. The Failure sensing method is the same as in the fan motor of the freezer. (refer to failure diagnosis function table for failure display)

8-1-10 ICE PLUS FRZ

1. The purpose of this function is to intensify the cooling speed of freezer and to increase the amount of ice.
2. Whenever selection switch is pressed, selection/release, the Icon will turn ON or OFF.
3. If there is a power outage and the refrigerator is powered on again, Ice Plus will be canceled.
4. To activate this function, press the Ice Plus key and the Icon will turn ON. This function will remain activated for 24 hrs. The first three hours the compressor and Freezer Fan will be ON. The next 21 hours the freezer will be controlled at the lowest temperature. After 24 hours or if the Ice Plus key is pressed again, the freezer will return to its previous temperature.
5. During the first 3 hours :
 - (1) Compressor and freezer fan (HIGH RPM) run continuously.
 - (2) If a defrost cycle begins during the first 90 minutes of ICE PLUS, the ICE PLUS cycle will complete its cycle after defrosting has ended.
If the defrost cycle begins when Ice Plus has run for more than 90 minutes, Ice Plus will run for two hours after the defrost is completed.
 - (3) If ICE PLUS is pressed during defrost, ICE PLUS Icon is on but this function will start seven minutes after defrost is completed and it shall operate for three hours.
 - (4) If Ice Plus is selected within seven minutes after compressor has stopped, the compressor (compressor delays seven minutes) shall start after the balance of the delay time.
 - (5) The fan motor in the freezer compartment runs at high speed during ICE PLUS.
6. For the rest of the 21 hours, the freezer will be controlled at the lowest temperature.

8-1-11 Alarm for Open Door

1. This feature sounds a buzzer when the freezer or refrigerator door is not closed within 1 minute after it is opened.
2. One minute after the door is opened, the buzzer sounds three times each for 1/2 seconds. These tones repeat every 30 seconds.
3. The alarm is cancelled when the freezer or the refrigerator is closed while the buzzer sounds.

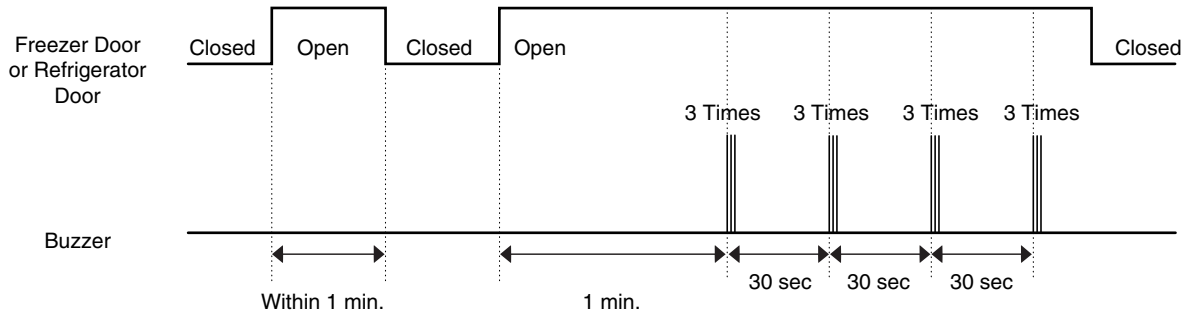

8-1-12 How to set the display mode and cancel it

1. With the refrigerator door open, keep pressing the Refrigerator Temp Button and ICE PLUS Button more than 5 seconds, then it goes to the display mode with Special Beep Sound With Special Beep Sound.
2. Perform the same way again to cancel the display mode.
3. All Freezing unit will be turned off at display mode (Exceptions : Lamp, Display)

8-1-13 Defrosting (removing frost)

1. Defrosting starts each time the COMPRESSOR running time reaches 7~50 hours.
2. For initial power on or for restoring power, defrosting starts when the compressor running time reaches 4 hours.
3. Defrosting stops if the sensor temperature reaches 46°F(8°C) or more. If the sensor doesn't reach 46°F(8°C) in 1 hours, the defrost mode is malfunctioning. (Refer to the defect diagnosis function, 8-1-14.)
4. Defrosting won't function if its sensor is defective (wires are cut or short circuited)

8-1-14 Defect Diagnosis Function

1. Automatic diagnosis makes servicing the refrigerator easy.
2. When a defect occurs, the buttons will not operate.
3. When the defect CODE removes the sign, it returns to normal operation (RESET).
4. The defect CODE shows on the Refrigerator and Freezer Display.

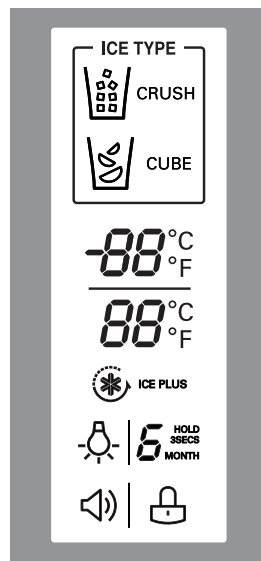

* LED check function : If simultaneously pressing Ice Plus button and freezing temperature adjustment button for a second, display LED graphics on. If releasing the button, the LED graphic displays the previous status.

ERROR CODE on display panel

NO	Error Detection Category	Error Display		Error Generation Factors	Remark
		Freezer Temperature	Ref. Temperature		
1	Normality			None	Normal operation of Display
2	Freezer Sensor Error	Er	FS	Short or Disconnection of Freezer Sensor	Each Sensor have to check disconnection
3	Refrigerator Sensor Error	Er	rS	Short or Disconnection of Refrigerator Sensor	
4	Defrosting Sensor Error	Er	dS	Short or Disconnection of Defrosting Sensor	
5	Icing Sensor Error	Er	IS	Short or Disconnection of Icing Sensor	
6	Poor Defrosting	Er	dH	Even though it is passed 1hour since then Defrosting, if Defrosting sensor is not over 46°F(8°C), it is caused	Temperature Fuse Disconnection, Heater disconnection, DRAIN Jam, Poor Relay for Heater
7	Abnormality of BLDC FAN Motor for Ice Making	Er	IF	It is caused when F/B signal isn't over 65seconds during BLDC FAN motor operating	Poor BLDC Motor connection, DRIVE IC, and TR
8	Abnormality of BLDC FAN Motor for Freezer	Er	FF	It is caused when F/B signal isn't over 65seconds during BLDC FAN motor operating	Poor BLDC Motor connection, DRIVE IC, and TR
9	Abnormality of BLDC FAN Motor for Mechanic Room	Er	CF	It is caused when F/B signal isn't over 65seconds during BLDC FAN motor operating	Poor BLDC Motor connection, DRIVE IC, and TR
10	Communication Error	Er	CO	Communication Error between Micom of Main PCB and Display Micom	Poor Communication connection, Poor TR of Transmitter and Receiver

NOTE) In the case of Room Temperature Seneor Error, "Er rt" appears on the Display when ICE PLUS KEY and Freezer Temp' KEY pressed at the same time for one second.

8-1-16 TEST Mode

1. The Test mode allows checking the PCB and the function of the product as well as finding out the defective part in case of an error.
2. The test mode is operated by pressing test button at main PCB controller.
3. While in the test mode, the function control button is not recognized, but the recognition tone sounds.
4. After exiting the test mode, be sure to reset by unplugging and then plugging in the appliance.
5. If an error, such as a sensor failure, is detected while in the test mode, the test mode is cleared and the error code is displayed.
6. While an error code is displayed, the test mode will not be activated.

Table 1. Function Test

MODE	OPERATION	FUNCTION	REMARKS
TEST1	Push test button one time at main PCB controller.	1) Operation of the COMPRESSOR and FAN(Freezer/Condenser/Icing) 2) Stepping DAMPER OPEN 3) Defrosting HEATER OFF 4) DISPLAY LED all ON	
TEST2	Push Test button one in TEST PCB MODE1.	1) Operation of the COMPRESSOR and FAN(Freezer/Condenser/Icing) 2) Stepping DAMPER CLOSE 3) Defrosting HEATER OFF 4) DISPLAY LED shows "22"	
TEST3	Push Test button one in TEST PCB MODE2.	1) The COMPRESSOR and the FAN(Freezer/Condenser/Icing) OFF 2) Stepping DAMPER CLOSE 3) Defrosting HEATER ON 4) DISPLAY LED shows "33"	Reset if the Temperature of the Defrosting Sensor is 46°F(8°C)or more.
RESET	Push Test button one in TEST PCB MODE3 .	Reset to the previously setting Before TEST MODE.	The compressor will Start after a 7-minute Delay.

8-2 PCB FUNCTION

8-2-1 Power Circuit

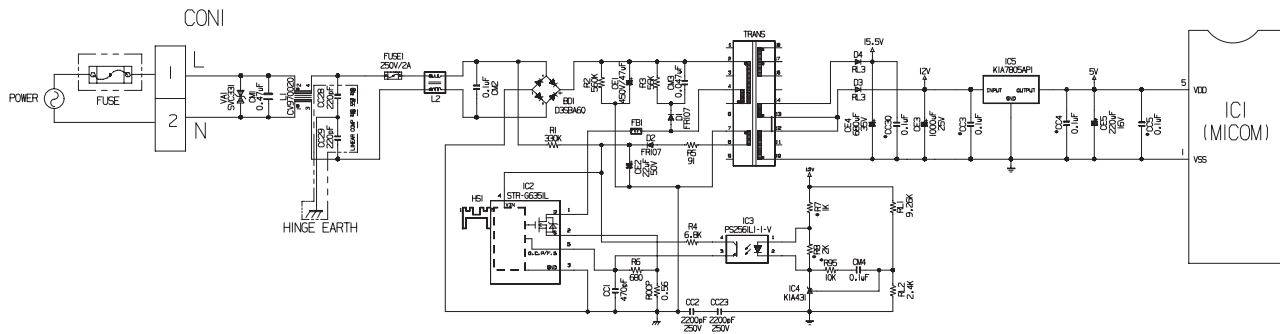

The secondary part of the TRANSFORMER is composed of the power supply for the display, the BLDC FAN Motor drive (15.5V), the relay drive (12 Vdc) and the MICOM and IC (5 Vdc).

The voltage for each part is as follows:

VA1 is a part for preventing over voltage and noise. When 230V or higher power is applied, the inside elements are shortcircuited and broken, resulting in blowout of the fuse in order to protect the elements of the secondary part of the TRANSFORMER.

PART	VA 1	CE 3	CE 4	CE 5
VOLTAGE	115 Vac	12 Vdc	15.5 Vdc	5 V

8-2-2 Load / Fan & Open Door Detection Circuit

1. Load Drive Condition Check

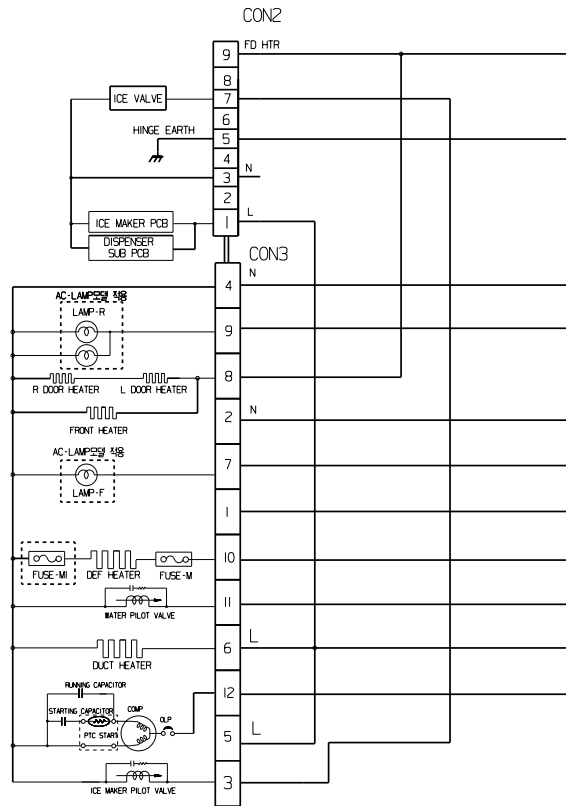

To measure outputs of the control board, check voltages between the pins for the following components :

Circuit	Pin Number	Pin Number	Output Voltage
I/Maker Pilot Valve	Con3 Pin3	Con3 Pin2	115 VAC
R/R Door, R/L Door Heater Front Heater	Con3 Pin8	Con3 Pin2	115 VAC
Def Heater	Con3 Pin10	Con3 Pin2	115 VAC
Water Pilot Valve	Con3 Pin11	Con3 Pin2	115 VAC
Compressor	Con3 Pin12	Con3 Pin2	115 VAC
Duct Heater	Con3 Pin6	Con3 Pin2	115 VAC

2-1 APPLY For AC Lamp Model(Optional)

LAMP-R	Con3 Pin9	Con3 Pin2	115 VAC
LAMP-F	Con3 Pin7	Con3 Pin2	115 VAC

2-2 Freezing compartment fan

	Pin2 & 3 of con4
MOTOR OFF	2V or less
MOTOR ON	13V~15V

2-3 Machine compartment fan

	Pin8 & 9 of con4
MOTOR OFF	2V or less
MOTOR ON	10V~14V

2-4 Icing compartment fan

	Pin5 & 6 of con4
MOTOR OFF	2V or less
MOTOR ON	10V~14V

3. Open Door Detection Circuit Check



Freezer/ Refrigerator Door	Measurement Location	Pin 11 & 12 of con4 Ref.Door Pin 5 & 6 of con6 Fre.Door
	Closed	
Open		0V

8-2-3 Temperature Sensor Circuit

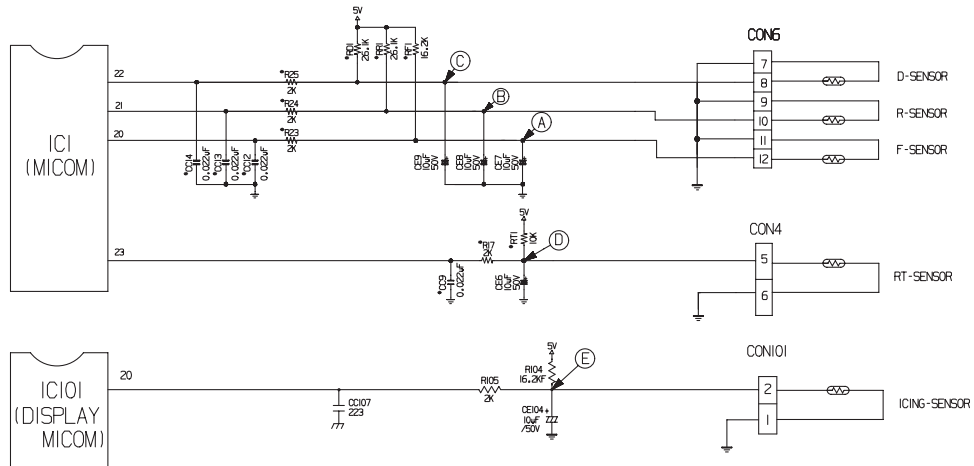

* ICING-SENSOR is located on the Display

The upper circuit reads refrigerator temperature, freezer temperature, Icing sensor temperature and defrost sensor temperature for defrosting and the indoor temperature for compensating for the surrounding temperature into MICOM. Opening or short state of each temperature sensor are as follows:

SENSOR	CHECK POINT	NORMAL (-30°C ~ 50°C)	SHORT-CIRCUITED	OPEN
Freezer sensor	POINT A Voltage	0.5V ~ 4.5V	0V	5V
Refrigerator sensor	POINT B Voltage			
Defrosting sensor	POINT C Voltage			
Room Temperature sensor	POINT D Voltage			
Icing sensor	POINT E Voltage			

8-3 RESISTANCE SPECIFICATION OF SENSOR

TEMPERATURE	RESISTANCE OF FREEZER/ICING SENSOR	RESISTANCE OF REFRIGERATOR & DEFROST SENSOR & ROOM SENSOR
- 20°C	22.3kΩ	77kΩ
- 15°C	16.9kΩ	60kΩ
- 10°C	13.0kΩ	47.3kΩ
- 5°C	10.1kΩ	38.4kΩ
0°C	7.8kΩ	30kΩ
+ 5°C	6.2kΩ	24.1kΩ
+ 10°C	4.9kΩ	19.5kΩ
+ 15°C	3.9kΩ	15.9kΩ
+ 20°C	3.1kΩ	13kΩ
+ 25°C	2.5kΩ	11kΩ
+ 30°C	2.0kΩ	8.9kΩ
+ 40°C	1.4kΩ	6.2kΩ
+ 50°C	0.8kΩ	4.3kΩ

- The resistance of the SENSOR has a $\pm 5\%$ tolerance.
- Measure the resistance of the SENSOR after leaving it for over 3 minutes in the measuring temperature. This delay is necessary due to sensor response speed.

8-2-4 Refrigeration Compartment Stepping Motor Damper Circuit

A reversible DC motor is used to open and close the damper.
 To open the damper, push test button once.
 To close the damper, push test button twice.

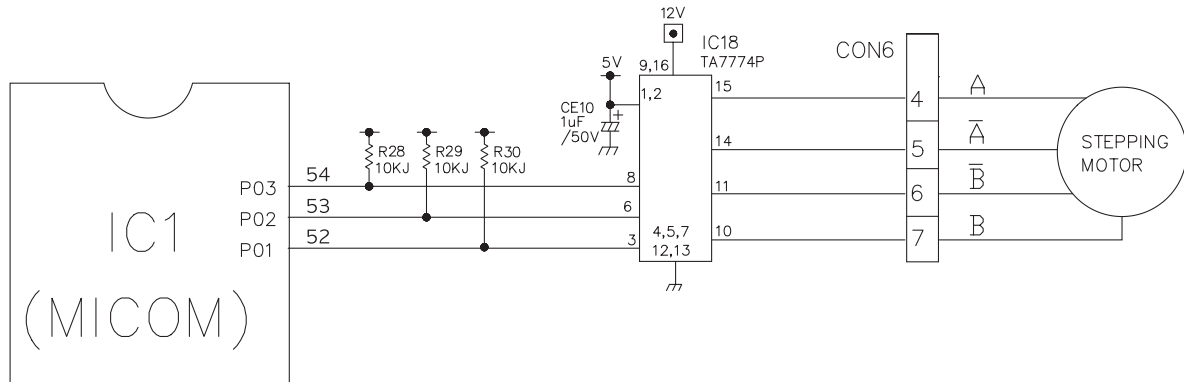

8-2-5 Dispenser Drive Circuit

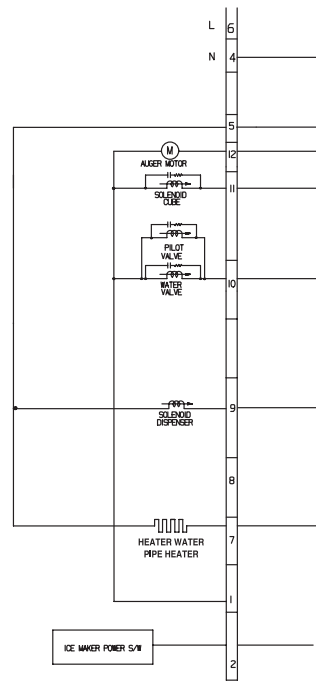

Circuit	Pin Number	Pin Number	Output Voltage
Auger Motor	Con1 Pin12	Con1 Pin4	115 VAC
Solenoid Cube	Con1 Pin11	Con1 Pin4	115 VAC
Pilot/ Water Valve	Con1 Pin10	Con1 Pin4	115 VAC
Solenoid Dispenser	Con1 Pin9	Con1 Pin4	115 VAC
Heater Water Pipe Heater	Con1 Pin7	Con1 Pin4	115 VAC

8-2-6 LED in Refrigerator/Freezer room (Apply for LED Model) (Optional)

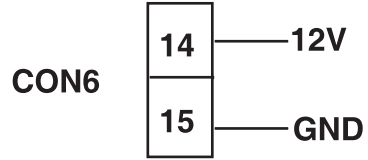

Circuit	Pin Number	Pin Number	Output Voltage
LED Module	Con6 Pin14	Con6 Pin15	12 VDC

8-3 TROUBLESHOOTING

PROBLEM	INDICATED BY	CHECK	CHECKING METHOD	CAUSE	SOLUTION	
POWER SOURCE is poor.	1. The whole	1. FREEZER/ REFRIGERATOR.	Check if FREEZER/ REFRIGERATOR DOOR IS OPEN and check display.	POWER SOURCE is poor.	Replace Main PWB	
		2. If LAMP is dim.	Check visually.	Applied voltage error.	Replace Main PWB	
	2. DISPLAY LED	3. The connection of the MAIN PWB CONNECTOR.	Check connection of CONNECTOR.	CONNECTOR connection is poor.	Reconnect CONNECTOR	
				TRANS FUSE is open.	Replace Main PWB	
COOLING is poor.	NO COOLING.	1. If the COMPRESSOR operate.	USE TEST MODE1 (forced COOLING). If less than 7 minutes pass after compressor shuts off, don't press the KEY and wait.	COMPRESSOR locked or blocked.	Replace OLP, PTC.	
				OLP, PTC is poor. COMPRESSOR RELAY is poor.	Replace MAIN PWB.	
				THE CONNECTING WIRE is poor.	Check the connection of the black wire of the MAIN PWB CONNECTOR (CON3).	
		2. If refrigerant is leaking.	Measure the amount of frost sticking on EVAPORATOR and the surface temperature of the condenser pipe.	Refrigerant leakage.	Replace the leaking part and replace any lost refrigerant.	
		FREEZER TEMPERATURE is incorrect	1. If FAN MOTOR operates.	USE TEST MODE1 (forced COOLING).	FAN MOTOR is poor.	Replace the FAN MOTOR.
					CONNECTING WIRE is poor.	Certify the MOTOR and the connection of the black wire of the MAIN PWB CONNECTOR (CON4).
	2. If DEFROSTING is normal.		Check the amount of frost sticking on the EVAPORATOR.	DEFROSTING is poor.	See DEFROSTING is poor.	
	3. If SENSOR is normal.		Of the Refrigerator SENSOR.	SENSOR RESISTANCE is poor.	Replace SENSOR.	
	4. Door Line contact.	Check the seal when the door is closed.	Door liner damaged.	Replace door liner.		

PROBLEM	INDICATED BY	CHECK	CHECKING METHOD	CAUSE	SOLUTION
COOLING is poor.	If REFRIGERATOR TEMPERATURE is too low.	1. If FREEZER TEMPERATURE is normal.	Check is FREEZER TEMPERATURE is too low.		Make sure the DOOR is attached.
		2. If amount of cool air from FAN MOTOR is sufficient.	Make sure that the amount and speed of cool air are sufficient by touching the check supplied on the REFRIGERATOR.	FAN MOTOR is poor.	Replace FAN MOTOR.
				Passage of cool air is blocked.	Remove impurities.
		3. Door Line contact.	Check door seal when door is closed.	EVA frozen.	See DEFROSTING is poor.
				Door liner damaged.	Replace Door liner.
DEFROSTING is poor.	NO DEFROSTING.	1. If HEATER emits heat.	USE TEST MODE3 (forced DEFROSTING).	HEATER disconnection.	Replace HEATER.
				TEMPERATURE FUSE disconnection.	Replace TEMPERATURE FUSE.
				Connection is poor.	Check EVAPORATOR connection and wire of MAIN PWB CONNECTOR.
				DEFROST-SENSOR is poor.	Replace DEFROST-SENSOR.
				HEATER RELAY is poor.	Replace RY4 of MAIN PWB.
		2. If DRAIN PIPE is blocked.	Check DRAIN PIPE.	DRAIN PIPE is blocked.	Remove ice and impurities.
					Check HEATER PLATE resistance.
3. If ice remains after DEFROSTING.	Make sure that DEFROST SENSOR is connected.	Connection is poor.	Reassemble the DEFROST-SENSOR.		
			Make sure that FREEZER /REFRIGERATOR DOOR is closed.	DOOR does not close properly.	Reassemble DOOR. Replace GASKET.

8-4 MAIN PWB ASSEMBLY AND PARTS LIST

8-4-1 Main PWB Assembly

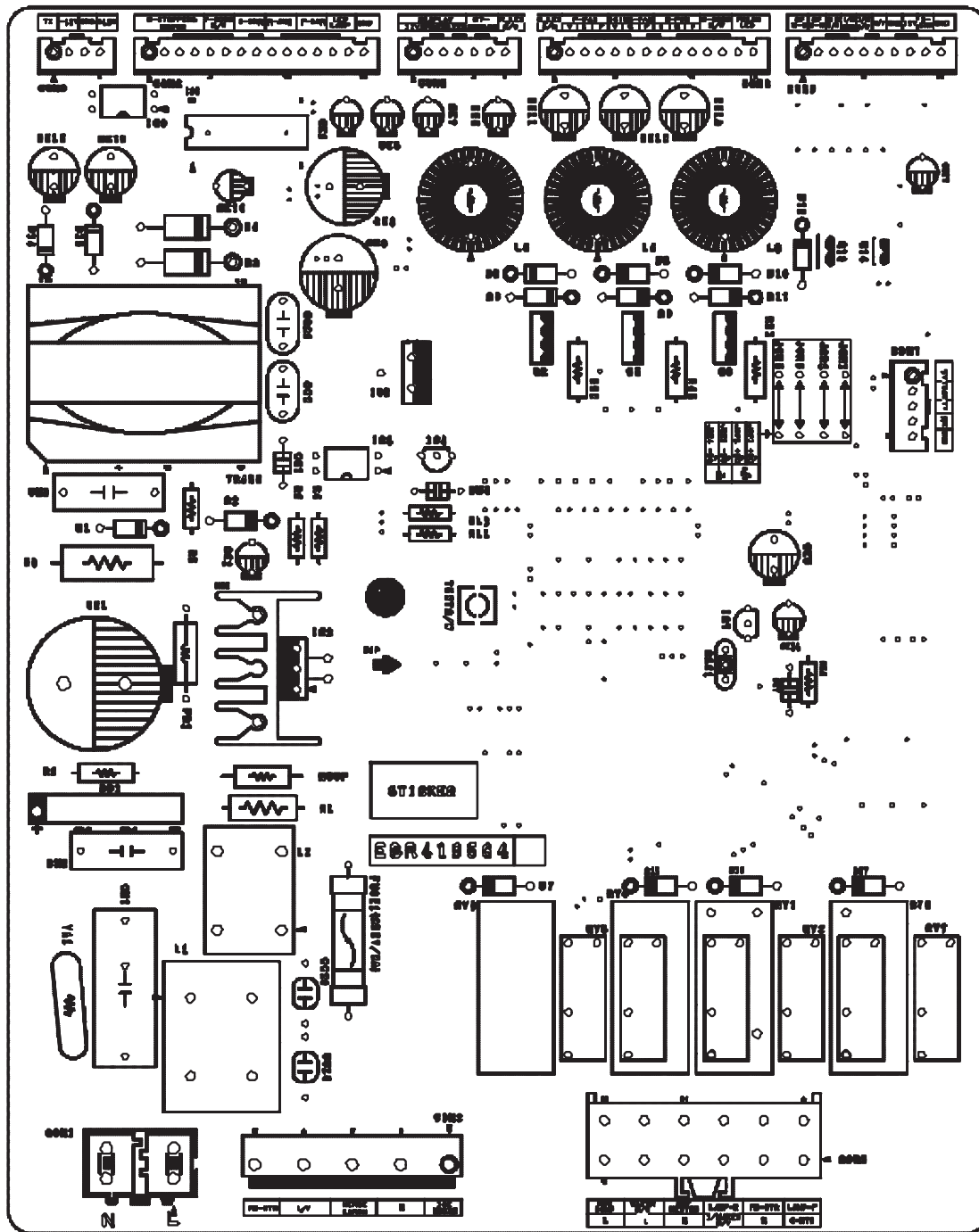

8-4-2 Dispenser Drive PWB Assembly

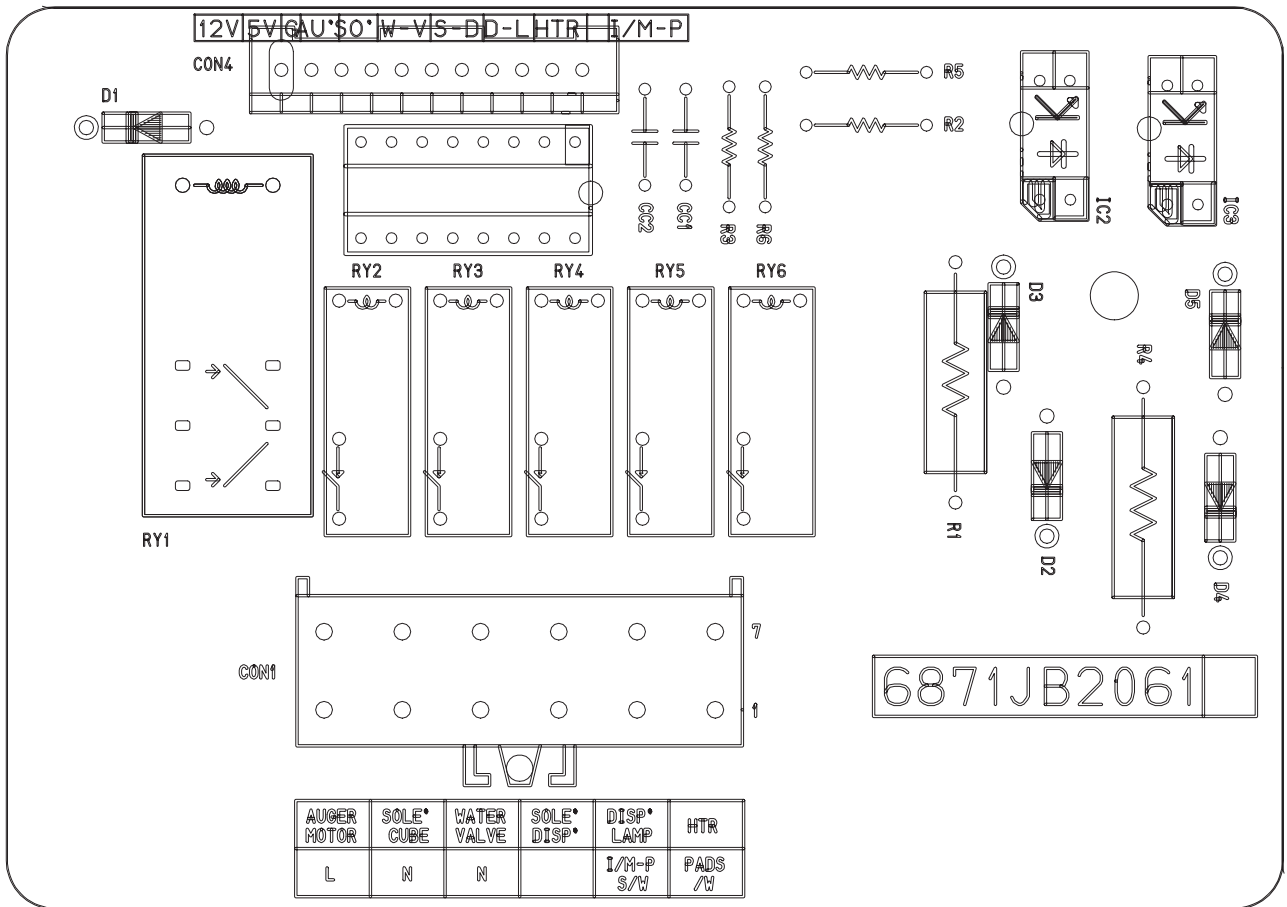

9. EXPLODED VIEW & REPLACEMENT PARTS LIST

CASE PARTS

CAUTION : Use the part number to order part, not the position number.

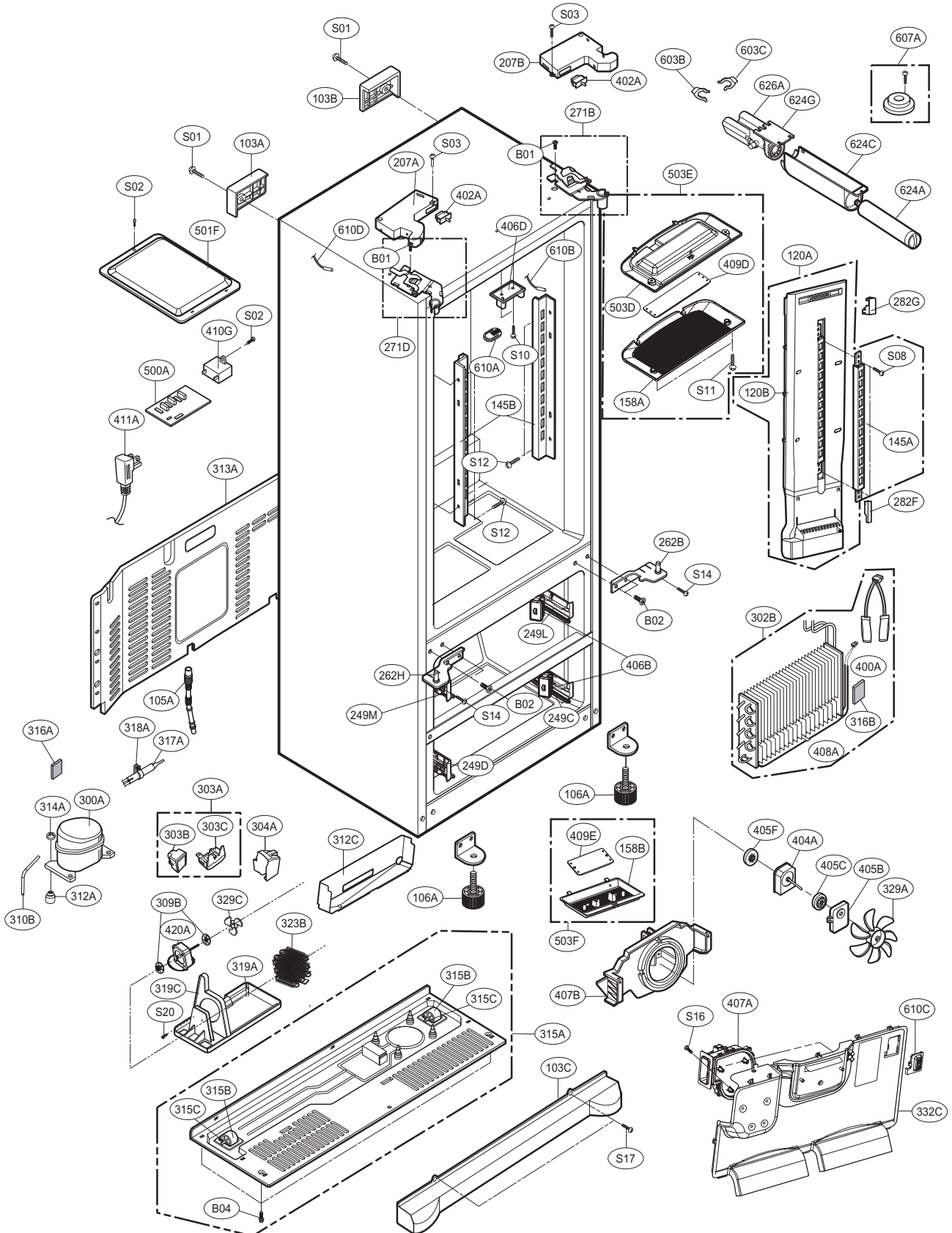

FREEZER PARTS

CAUTION : Use the part number to order part, not the position number.

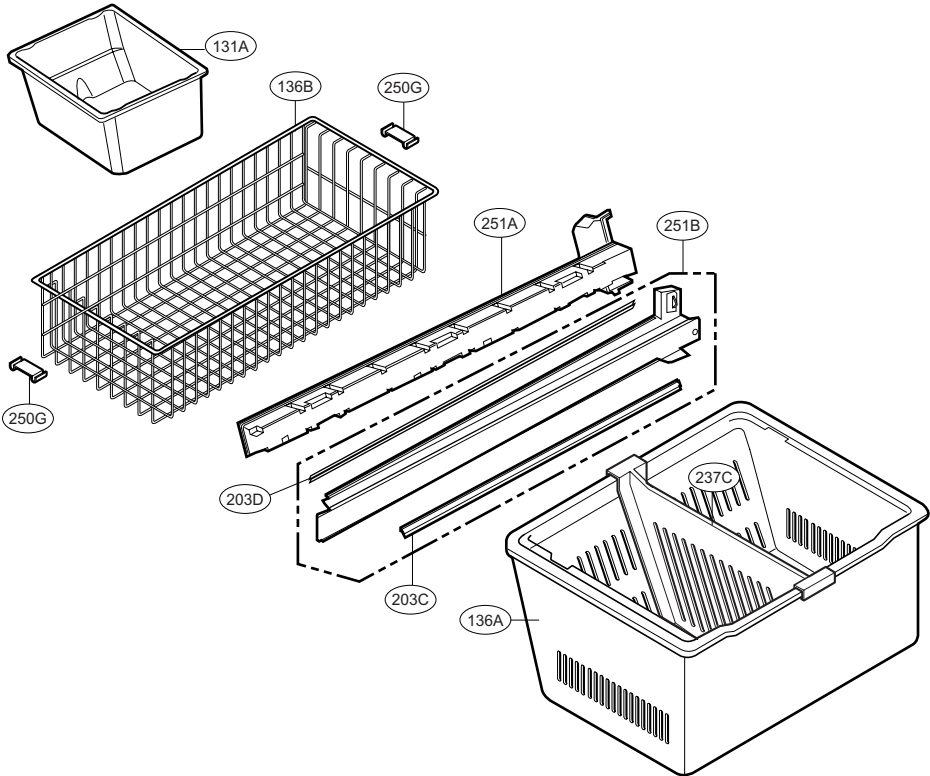

REFRIGERATOR PARTS

CAUTION : Use the part number to order part, not the position number.

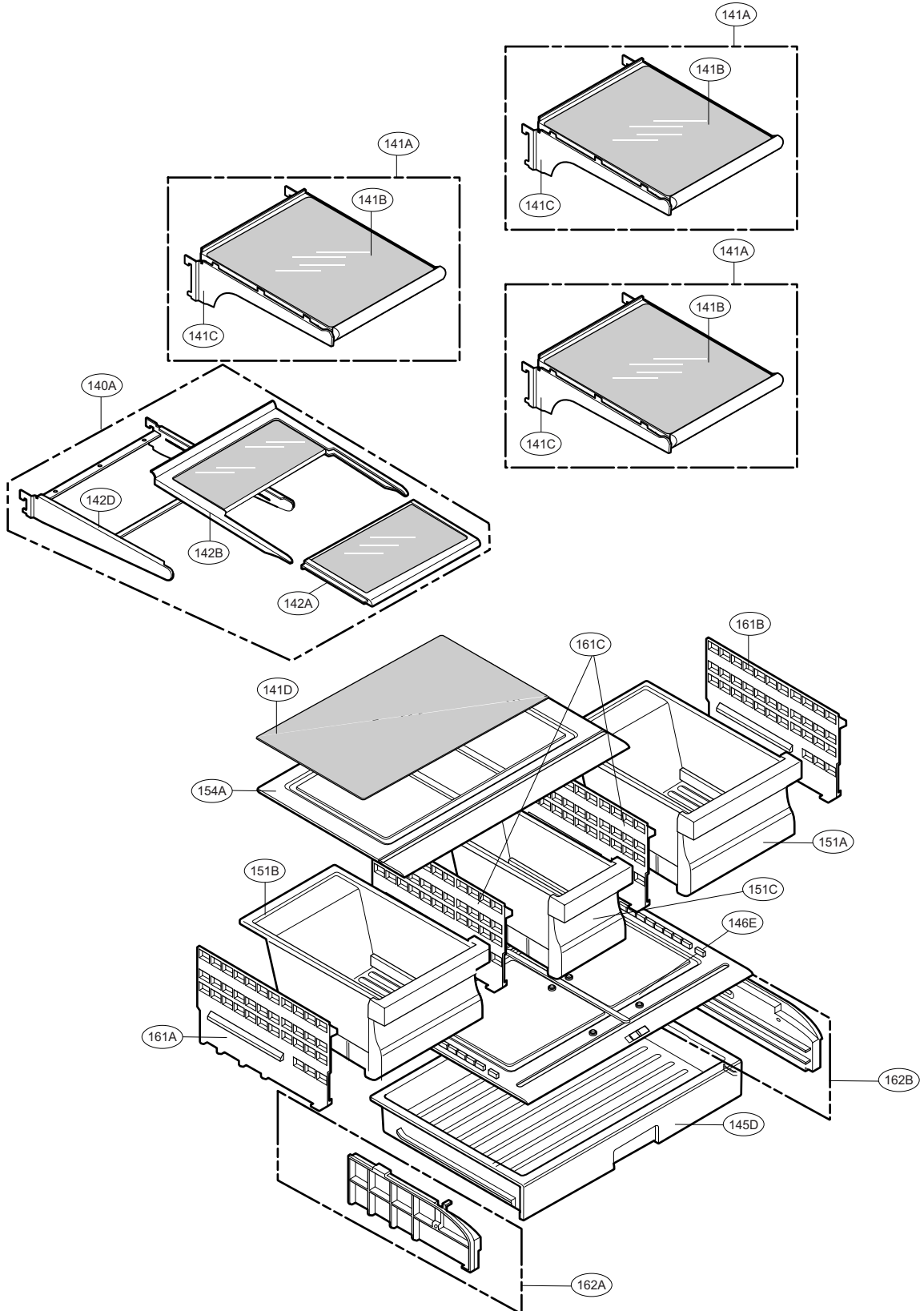

* : on some models

DISPENSER PARTS

CAUTION : Use the part number to order part, not the position number.

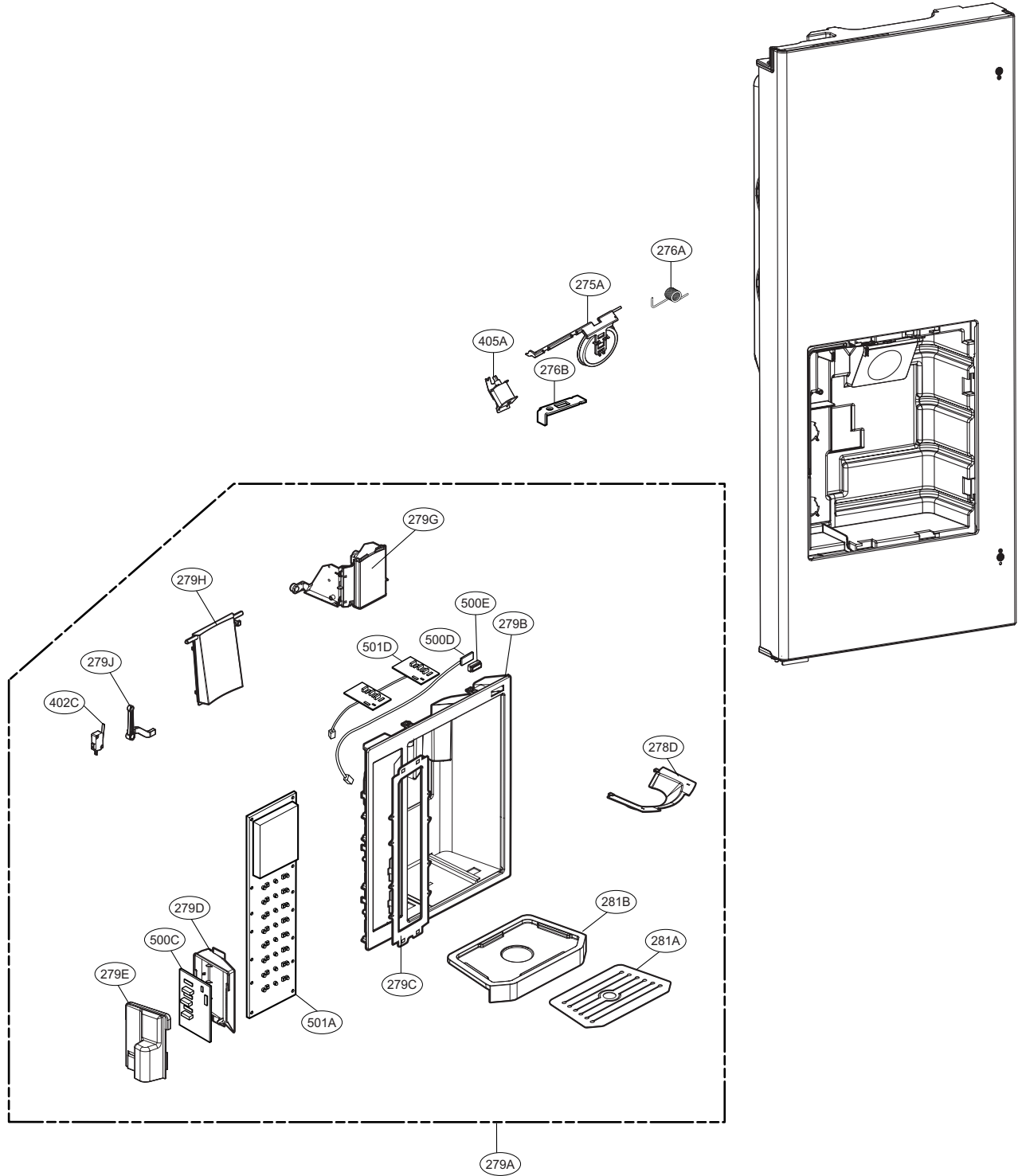

ICE & MAKER PARTS

CAUTION : Use the part number to order part, not the position number.

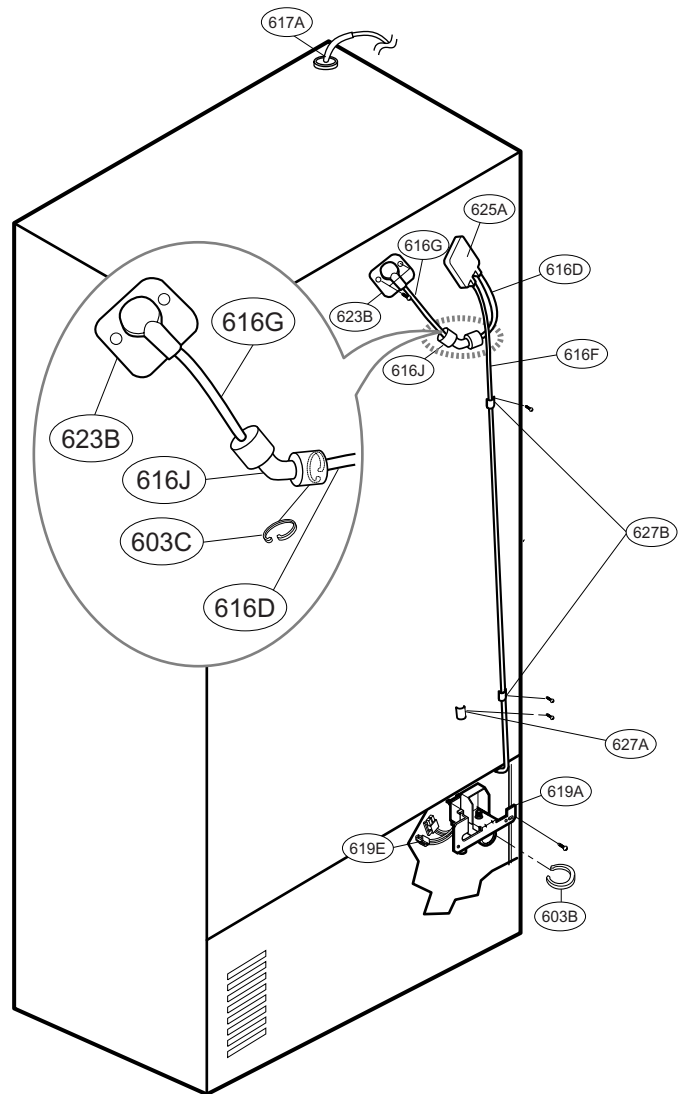
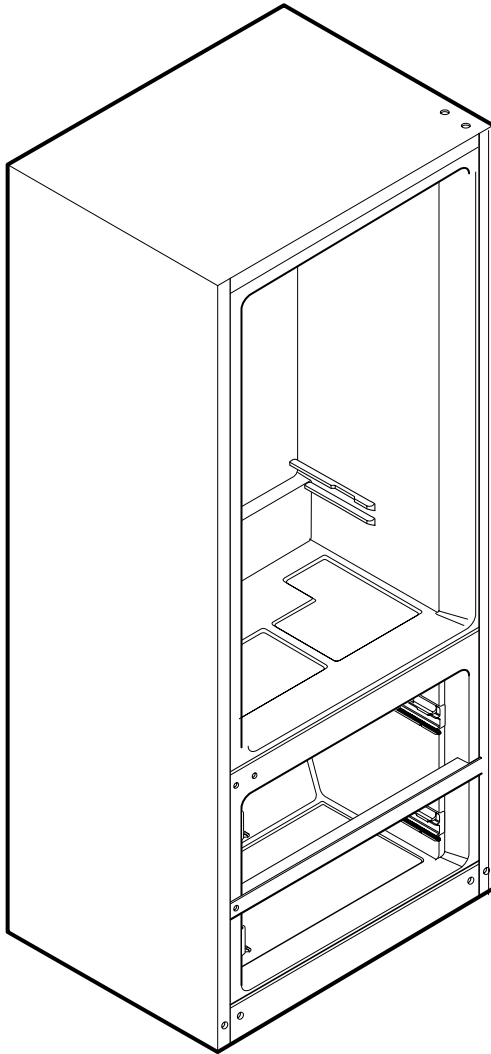

ICE BANK PARTS

CAUTION : Use the part number to order part, not the position number.

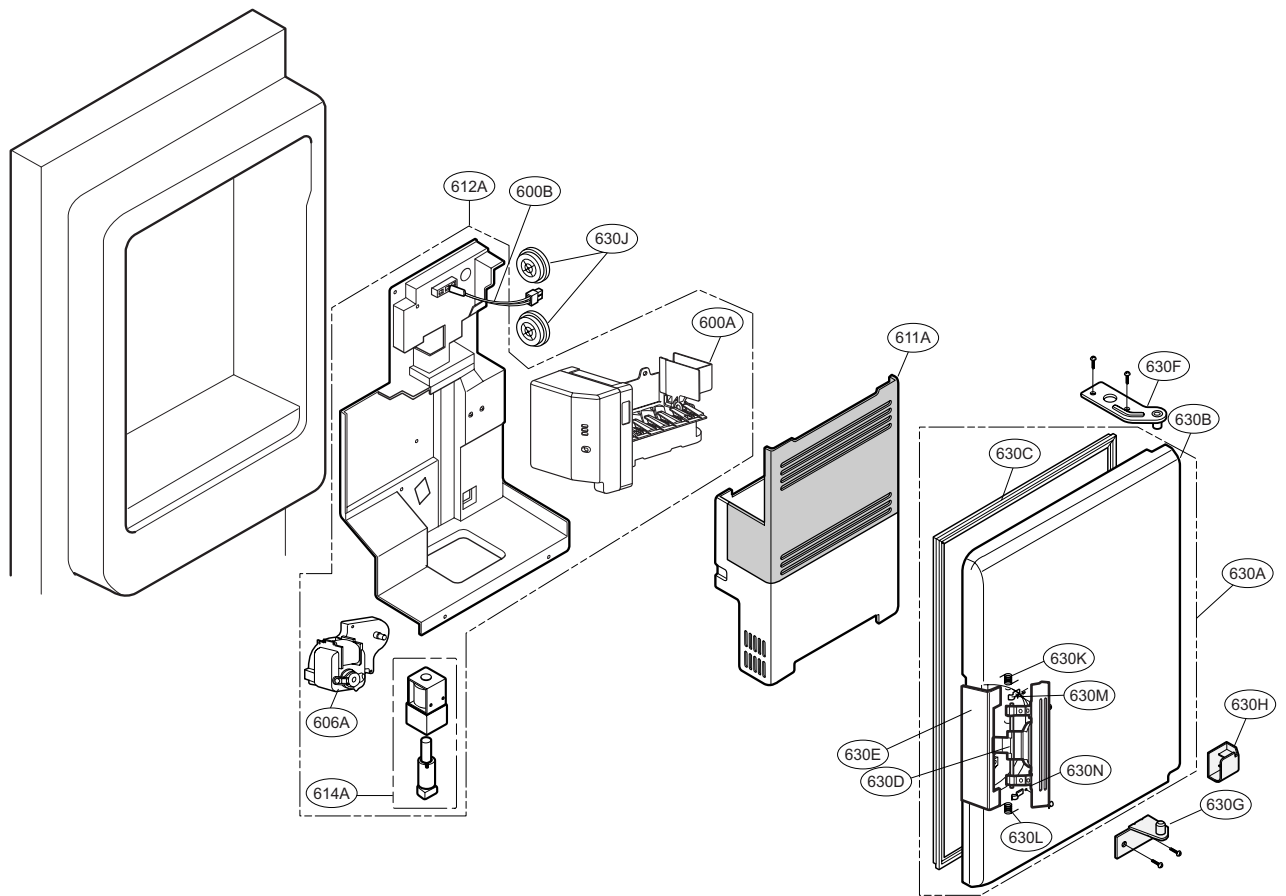



P/No. MFL48178814

JUL., 2009 Printed in Korea