

This Owner's Manual is provided and hosted by [Appliance Factory Parts](#).



FISHER & PAYKEL BGB132-BI Owner's Manual

[Shop genuine replacement parts for FISHER & PAYKEL
BGB132-BI](#)



[Find Your FISHER & PAYKEL Grill Parts - Select From 8 Models](#)

----- Manual continues below -----



THE PROFESSIONAL SIDE BURNER

Installation, Use and Care Guide



INSTRUCTIONS BEFORE PROCEEDING
Cover the burner before lighting.
Turn the selected knob to "OFF".
Turn the main gas supply on.
If the burner does not light, shut off gas and call for service.

IGNITION INSTRUCTIONS

For Side Burners
Hold the ignition button for 5 seconds to light the burner. If the burner does not light, turn the selected knob to "HI". If the burner does not light after 5 seconds, turn the knob to "OFF" and wait 1 minute before trying to light again. If the burner fails to light, turn the knob to "OFF" and call for service. For more information, see the Installation and Care Manual for match lighting instruction. For burner replacement, see the Installation and Care Manual.

MODELS:

- BGB131
- BGB132
- BGB131-BI
- BGB132-BI



A MESSAGE TO OUR CUSTOMERS

We are glad that you selected the professional side burner by DCS. Because this appliance contains features not found on any other burner, we recommend that you read this entire booklet before your first use. Keep it in a handy place as it has answers to questions that may occur during future use.

Feel free to contact us if we can help you. When you write please include the model and serial number of the Burner. We thank you for buying the professional side burner and wish you many years of enjoyment.

To help serve you better, please fill out and submit your Product Registration by visiting our website at www.dcsappliances.com and selecting "Customer Care" on the home page and then select "Product Registration".

For your convenience, product questions can be answered by a DCS Customer Care Representative by phone: 1-888-936-7872, or email: customer.care@fisherpaykel.com.

NOTE: Please write the Model, Code and Serial Numbers on this page for references (located on the inside of the left side of the appliance)

MODEL NUMBER _____ CODE _____ SERIAL NUMBER _____

NOTE: Inspect the product to verify that there is no shipping damage. If any damage is detected, call the shipper and initiate a damage claim. DCS by Fisher & Paykel is not responsible for shipping damage.

DO NOT discard any packing material (box, pallet, straps) until the unit has been inspected.

WARNING!

Improper installation, adjustment, alteration, service or maintenance can cause property damage, injury or death. Read the installation, operating and maintenance instructions thoroughly before installing, using or servicing this equipment.

WARNING!

If the information in this manual is not followed exactly, a fire or explosion may result causing property damage, personal injury or death. Do not store or use gasoline or other flammable vapors and liquids in the vicinity of this or any other appliance. An LP cylinder not connected for use shall not be stored in the vicinity of this or any other appliance.

WARNING!

Do not try lighting this appliance without reading the "Lighting Instructions" section of this manual. This outdoor cooking gas appliance is not intended to be installed in or on recreational vehicles, boats or in a non-ventilated room. For outdoor use only.

FOR YOUR SAFETY

If You Smell Gas:

1. Shut off gas to the appliance.
2. Extinguish any open flames.
3. Open lid.
4. If odor continues, immediately call your gas supplier or your fire department

Installation and service must be performed by a qualified installer, service agency or the gas supplier.

PLEASE RETAIN THIS MANUAL FOR FUTURE REFERENCE.

TABLE OF CONTENTS

SAFETY PRACTICES AND PRECAUTIONS	3-4
INSTALLATION	
Installation of Side Burner on 30" Grill	4-7
Installation of Side Burner Built-in Model	8-9
Gas Hook-up	10-11
Leak Testing	12
Burner Adjustment	12
Installer Checklist	13
USING THE SIDE BURNER	
Lighting Instructions	14
CARE AND MAINTENANCE	15
TROUBLESHOOTING	16
PARTS LIST	
Single Side Burner - BGB131 & BGB131-BI	17
Double Side Burner - BGB132 & BGB132-BI	18
WIRING DIAGRAM	
Single and Double Side Burner	19
SERVICE	20
WARRANTY	21-22

SAFETY PRACTICES & PRECAUTIONS

Improper use or installation is dangerous. Carefully follow these instructions.

- Always remove the cover before lighting the professional side burner. Never use the side burner if a leak is present.
- Do not use a flame to check for gas leaks.
- Do not let children use the side burner.
- Do not leave children unattended near the side burner.
- Never let children crawl or hang on the side burner.
- Exercise care when operating the side burner. The burner grate can get hot enough to cause burns during operation.
- Never leave the side burner on unattended.
- Always wait 5 minutes before relighting the burner to allow any accumulated gas to dissipate. Should the burner go out during use, turn off the gas valve and wait 5 minutes before attempting to relight. Always follow the lighting instructions. Never lean over a lit burner.
- Never cook without the drip pan in place, pushed all the way to the rear of the burner box.
- Use only in well ventilated areas.
- Do not use in garages, breezeways, sheds, or other such enclosed areas.
- Keep the area surrounding the side burner clear and free from combustible materials, gasoline, other flammable liquids or vapors, charcoal lighter fluid, and trash.
- Do not obstruct the flow of combustion and ventilation air to the side burner. On cart mounted units, keep area beneath the burner free of debris. If the burner is built-in, do not store gas cylinders beneath the unit without adequate ventilation.



WARNING!

Do not store items of interest to children above or at the back of any appliance. Children could be seriously injured if they should climb onto the appliance to reach these items.

- Keep the side burner covered when not in use.
- Never connect an unregulated gas line to the side burner.
- If the side burner has not been used for an extended period of time (over winter, for example) the unit should be checked for gas leaks and obstructions in the burner.
- Thoroughly clean the side burner on a regular basis.
- Only use the side burner with the type of gas specified on the rating plate. To change from LP gas to natural, or vice versa, a factory conversion kit (see page 10 for conversion kit information) is required.

NOTE:

This product must be installed by a licensed plumber or gas fitter when installed within the Commonwealth of Massachusetts.

SAFETY PRACTICES & PRECAUTIONS

SPIDER AND INSECT WARNING!

Spiders and insects can nest in the burner(s) or orifices of this or any other gas appliance, and can block or restrict the burner. This can cause a flash back to the control panel. This is a very dangerous condition which can cause a fire to occur, thereby damaging the unit and making it unsafe to operate.

You must inspect the burner(s) at least once a year or immediately if any of the following conditions occur:

1. The smell of gas in conjunction with the burner flames appearing yellow.
 2. The side burner(s) does not reach temperature.
 3. The side burner(s) heats unevenly.
 4. The burner(s) make popping noises.
- Do not attempt to disconnect any gas connections while your burner is in use, or the gas supply is on.
 - When the side burner is stored indoors the gas supply must be disconnected and, if using an LP gas cylinder, the cylinder must be stored outdoors in a well-ventilated area.
 - Keep any electrical supply cord away from the heated surfaces of the professional side burner.
 - On cart mounted units, never move without first allowing the side burner and/or grill to cool and ensuring that the gas supply is turned off. Fold the side shelf down, and push; never pull the grill.
 - Never use the side burner in a windy area.

INSTALLATION

INSTALLATION OF SIDE BURNER ONTO 30" CART (BGB 131/132 MODELS ONLY)

SIDE BURNER DIMENSIONS

Single Side Burner

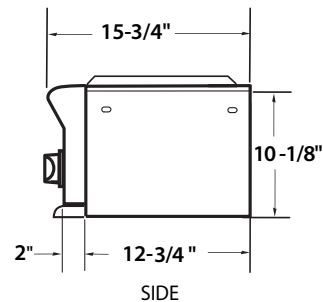
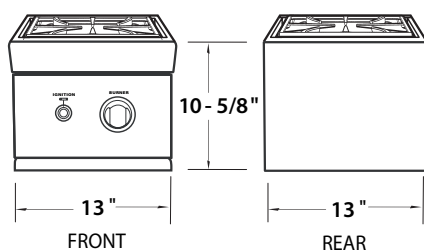

Double Side Burner

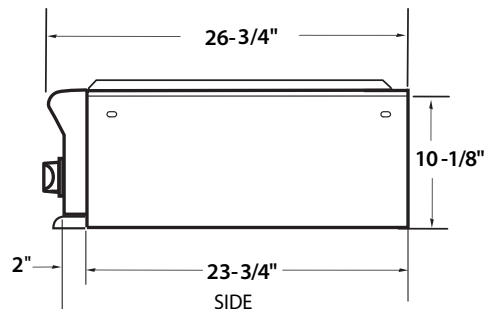
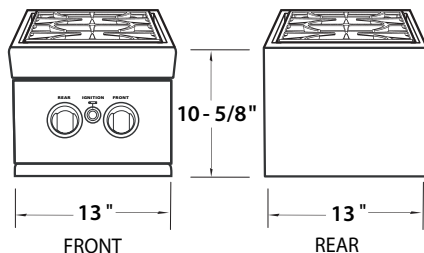

INSTALLATION

INSTALLATION OF SIDE BURNER ON 30" CART

Important!

Read all instructions before you begin. Do not jump ahead or skip any step. Side shelf must be removed prior to installation.

CAUTION!



Some parts have sharp edges; care must be taken when handling the various components to avoid injury. Please, read safety information provided in these instructions before beginning assembly. Wear gloves when handling.





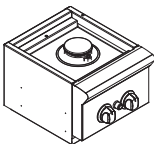
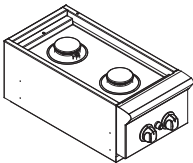
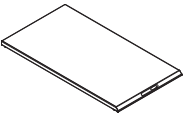
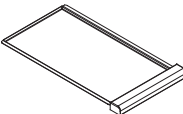
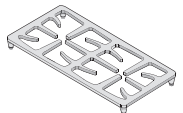

GETTING STARTED

- Remove packaging.
- Remove side burner from inside and discard packing.



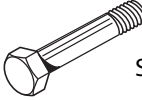

CONTENTS INCLUDED:

Your side burner is packaged in one box. The box contains your side burner and a universal hardware kit to be used for installation and may contain extra hardware for your convenience.

Contents	Description	Qty.	Part No.
	BGB131-BIL	1	70175
	BGB131-BIN	1	70176
	BGB131L	1	70177
	BGB131N	1	70515
	BGB132-BIL	1	70178
	BGB132-BIN	1	70179
	BGB132L	1	70180
	BGB132N	1	70604
	Cover (131)	1	218614
	Cover (132)	1	218613
	Drip Pan (131)	1	224826
	Drip Pan (132)	1	237358
	Grate (131)	1	210645
	Grate (132)	1	220496
	Instruction	1	238044

Contents	Qty.	Part No.
 Washer Flat 1/4x.938	2	211375
 Screw 1/4-20x1/2"	5	211323
 Screw #10	4	211278
 Washer #10	4	211371
 Nut #10	4	211394
 Shoulder Bolt 1/4-20x5/16	1	211442
 Screw 10-24x1/2 Pan Head	2	211242

Tools Required:

	Eye Goggles
	Work Gloves
	Power Screwdriver or Variable Speed Drill with Phillips -tip #2 Attachment
	10 mm Wrench or Socket
	3/32" Allen Wrench

INSTALLATION

INSTALLATION OF SIDE BURNER ON 30" CART

STEP 1

Remove the cover, grate, and drip pan from the side burner.

STEP 2

Bolt the support brackets to the grill cart side panel with (4) 1/4 x 20 bolts provided.

Note:

For the BGB131 side burner only, use (2) #10 sheet metal screws (211242) to bolt the back support bracket.

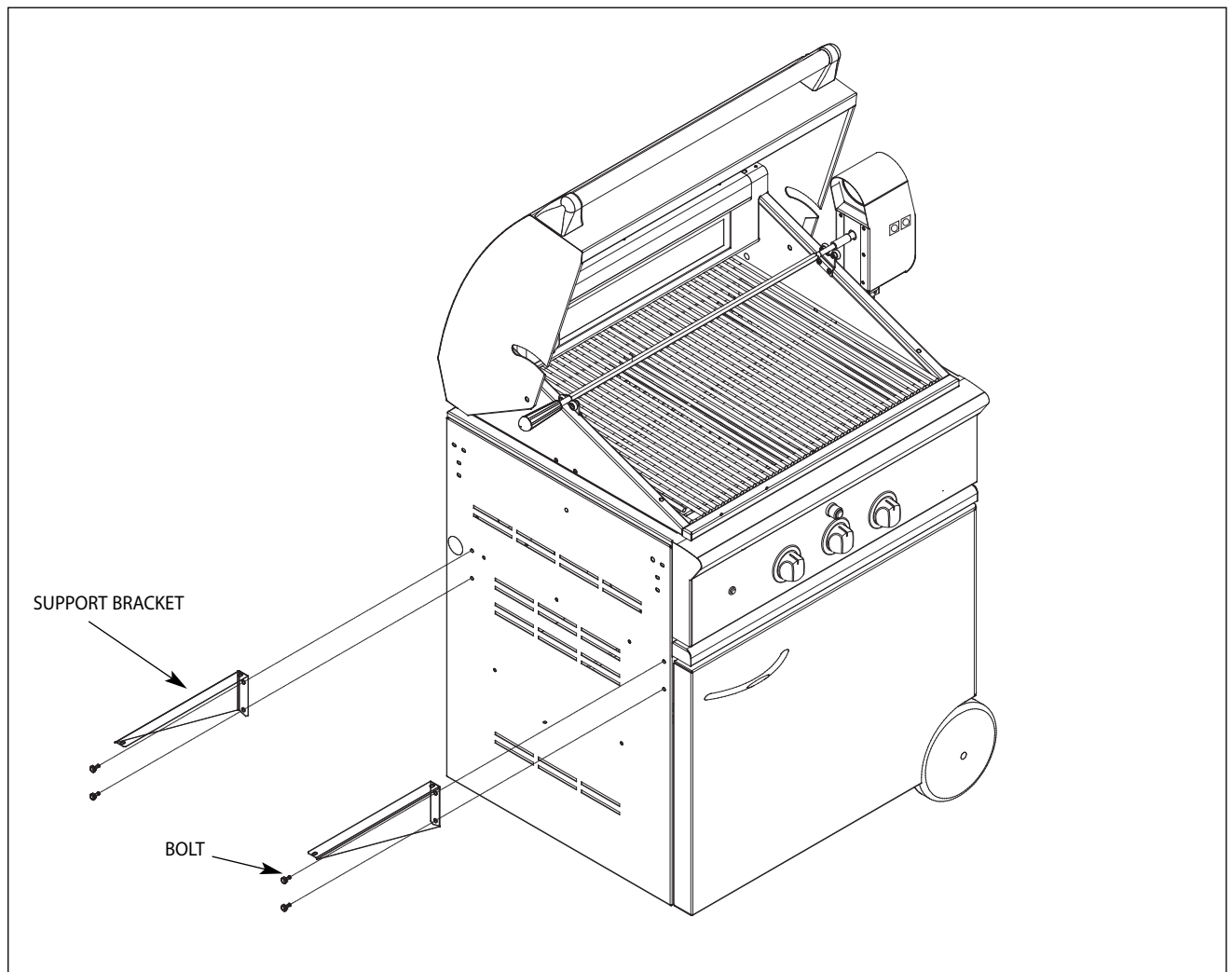

FIG. 01

INSTALLATION

INSTALLATION OF SIDE BURNER ON 30" CART

STEP 3

1. Bolt the side burner to the grill cart side panel from the under side of the burner assembly with a shoulder bolt in the front and 1/4 x 20 bolt in the back as shown. Do not forget to use 1/4 flat washers. Do not tighten. Adjust the side burner until it is level to the grill; then tighten securely.
2. Bolt the support brackets to the bottom of the side burner with (4) #10-24 machine screws, nuts and washers provided.
3. Replace the drip pan, grate and cover.

Note:

Once the side burner is assembled, refer to the "Gas Requirements" section for proper gas hook-up requirements.

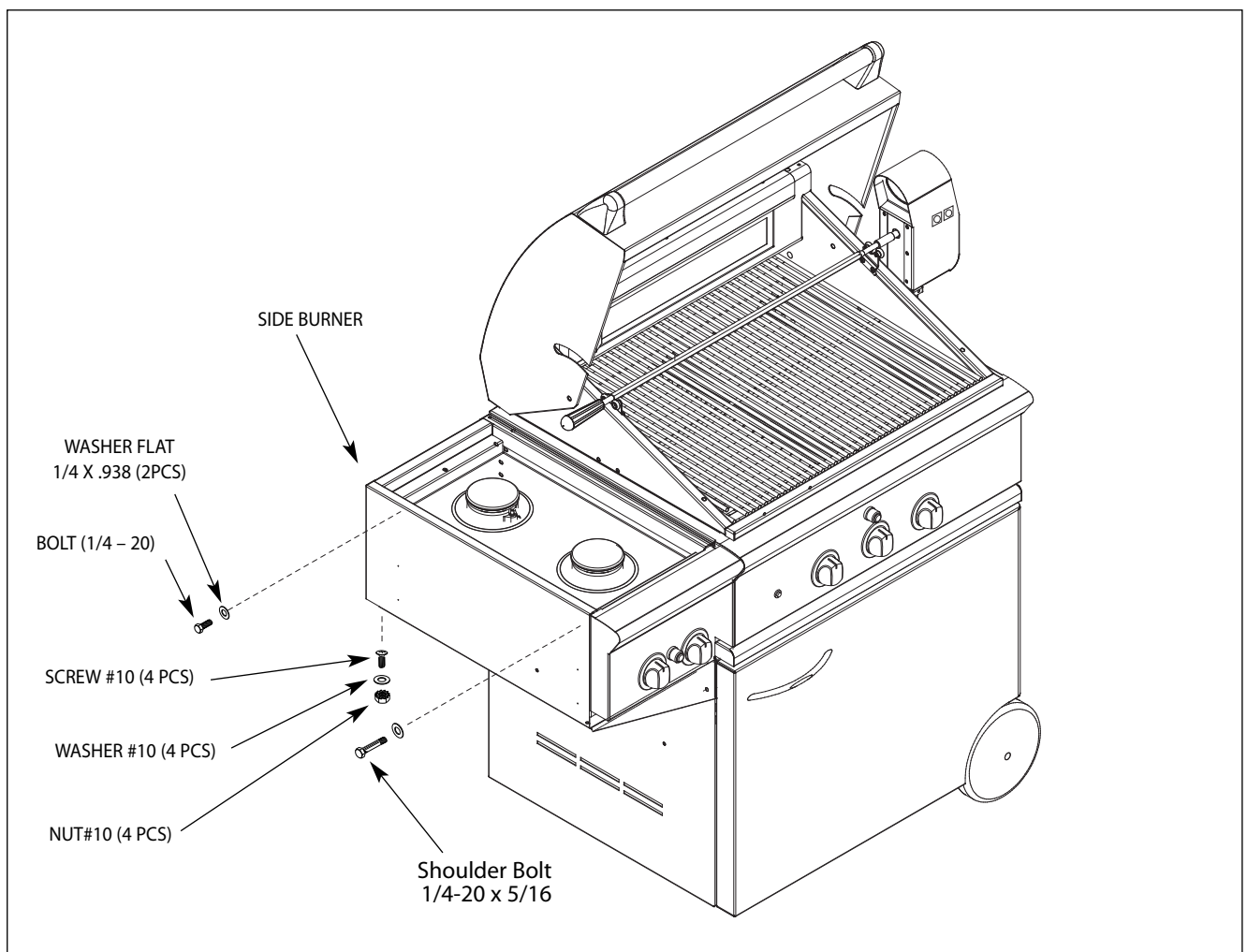

FIG. 02

INSTALLATION

INSTALLATION OF SIDE BURNER, BUILT-IN MODEL

All BGB131-BI and BGB132-BI models can be installed into a combustible enclosure with zero clearance from the back, side and bottom below the counter top level as shown in Fig. 03.

A minimum of 6" from the back and sides must be maintained from the professional side burner above the cooking surface (see Fig. 03).

When determining a suitable location, take into account concerns such as exposure to wind, proximity to traffic paths, and keeping any gas supply lines as short as possible. Locate the side burner only in a well-ventilated area. Never locate the side burner in a garage, breezeway, shed, or other such enclosed areas.

It is recommended that ventilation holes are provided in the enclosure in the event of a gas leak. The counter and supporting ledges or deck must be level and flat.

Important!

Gas fittings, regulator, and installer-supplied shut-off valves must be easily accessible.

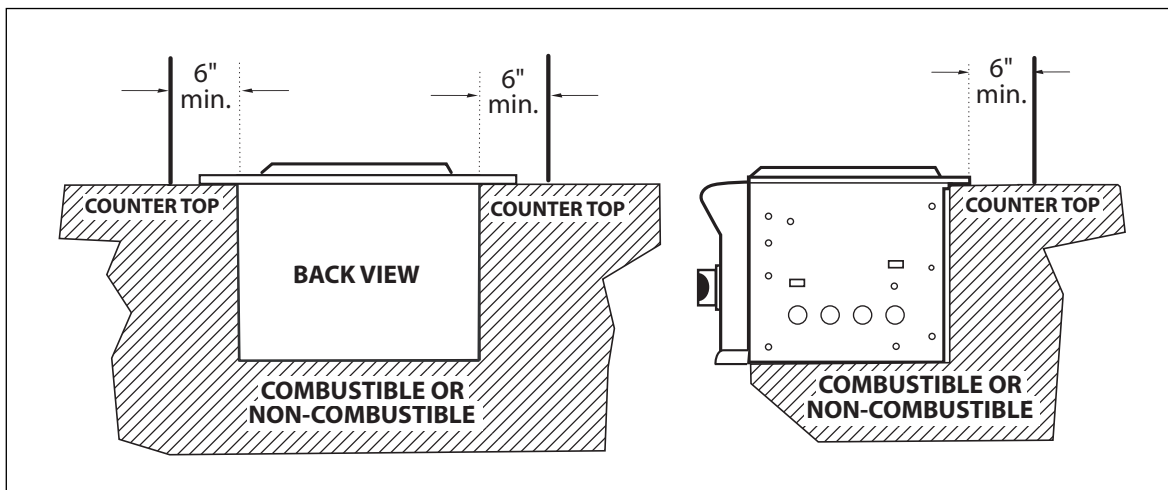

FIG.03

INSTALLATION

INSTALLATION OF SIDE BURNER, BUILT-IN MODEL

SIDE BURNER DIMENSIONS

Single Side Burner

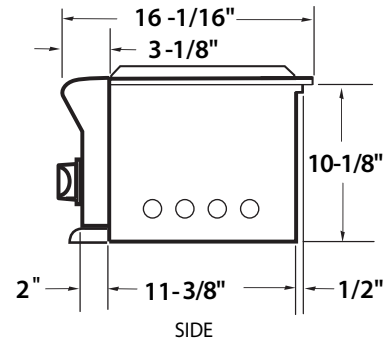
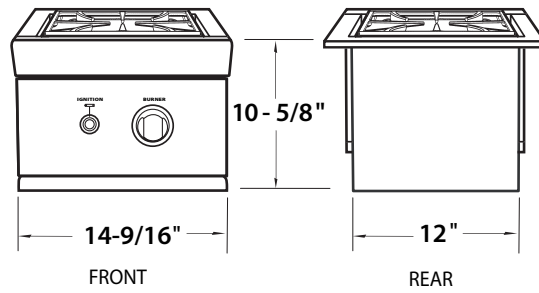

Double Side Burner

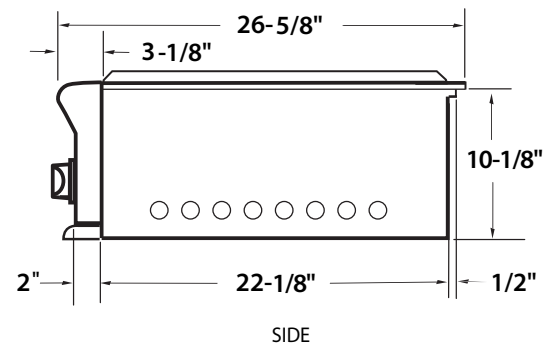
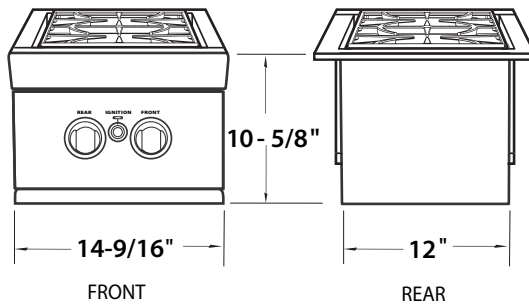

STANDARD CONSTRUCTION CUTOUT REQUIREMENTS

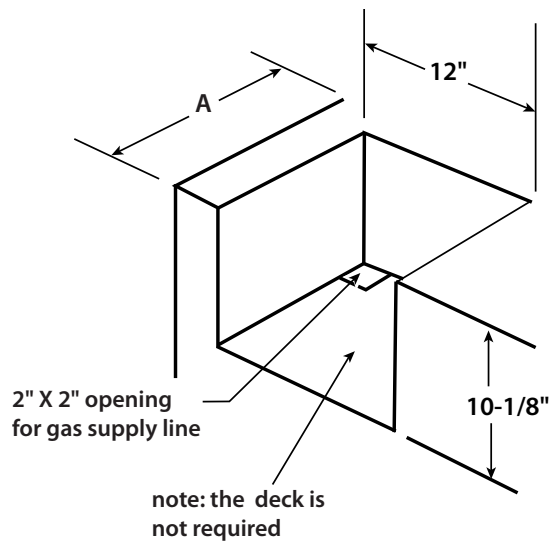

MODEL	A
BGB131-BI	12"
BGB132-BI	22-3/4"

INSTALLATION

GAS HOOK-UP

GAS REQUIREMENTS:

Verify the type of gas supply to be used, either natural or LP. Make sure the marked gas on the appliance rating plate(s) and hook-up kit agrees with that of the supply.



IMPORTANT!

Never connect an unregulated gas line to the appliance.

An installer supplied gas shut-off valve must be installed in an easily accessible location. All installer supplied parts must conform to local codes, or in the absence of local codes, ANSI/NFPA-770-1984.

All pipe sealants must be an approved type and resistant to the actions of LP gases. Never use pipe sealant on flare fittings.

All gas connections should be made by a qualified technician and in accordance with local codes and ordinances. In the absence of local codes, the installation must comply with the National Fuel Gas Code ANSI Z223.1.

Gas conversion kits are available from the factory. When ordering, have the model number, and the type of gas (natural or LP) which you need.

Total gas consumption of the professional side burner with burner(s) on "HIGH" – Table 1 below.

TABLE 1

MODEL	Btu/hr
BGB131	17,000
BGB132	34,000
BGB131-BI	17,000
BGB132-BI	34,000

The appliance and its individual shut-off valve must be disconnected from the gas supply piping system during any pressure testing of that system at test pressures in excess of 1/2 PSIG (3.5kPa.).

The appliance must be isolated from the gas supply piping system by closing its individual manual shut-off valve during any pressure testing of the gas supply piping system at test pressures equal to or less than 1/2 PSIG (3.5 kPa.).

The installation of this appliance must conform with local codes or in the absence of local codes, with the National Fuel Gas Code, ANSI Z223.1. Installation in Canada must be in accordance with the Standard CAN1-b149 and/or .2 (installation code for gas burning appliances and equipment) and local codes.

NATURAL GAS HOOK-UP:

CONNECTION: 1/2" NPT male with 3/8" flare adapter.

OPERATING PRESSURE: 4.0" W.C.

SUPPLY PRESSURE: 5" to 14" W.C. If in excess of 14" W.C., a step down regulator is required.

Check with your local gas utility company or with local codes for instructions on installing gas supply lines. Be sure to check on type and size of run, and how deep to bury the line. If the gas line is too small, the professional side burner will not function properly.

INSTALLATION

GAS HOOK-UP

NATURAL GAS HOOK-UP (continued)

To hook-up the fittings supplied with the side burner, assemble as shown in Fig.04. Use joint compound on male threads only.

Do not use joint compound on the flare end of the 1/2" NPT to 3/8" flare adapter. Ensure that the regulator arrow points in the direction of gas flow-towards the unit, away from the supply.

Do not forget to place the installer-supplied gas valve in an accessible location.

LP GAS HOOK-UP

CONNECTION: 1/2" NPT male with 3/8" flare adapter (included). Use 90° elbow 1/2" NPT with 3/8" flare (P/N 212394) for side mount models only when installing on the cart. Use sealer on 1/2" NPT threads only.

OPERATING PRESSURE: 10.0" W.C. side burner uses the LP regulator from adjoining grill.

SUPPLY PRESSURE: 11" to 14" W.C.

Apply joint compound to the threaded end of the side burner gas inlet and tighten the adapter to the pipe. Assemble the 24" and 30" hoses to the 3/8" flare tee, as shown in Fig.05. Tighten the regulator hose to the remaining fitting of the 3/8" flare tee.

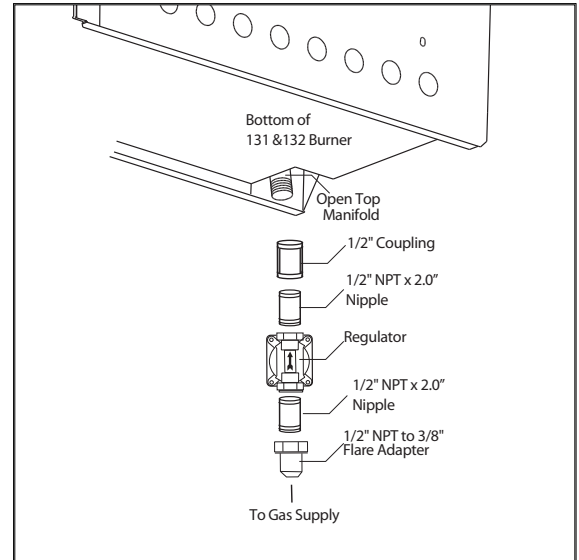

FIG. 04 Natural Gas

LP TANK REQUIREMENTS

- A dented or rusty LP gas cylinder may be hazardous and should be checked by your LP supplier. Never use a cylinder with a damaged valve.
- The LP gas cylinder must be constructed and marked in accordance with the specifications for LP gas cylinders of the U.S. Department of Transportation (DOT) and designed for use with a Type 1 system only.
- Do not change the regulator/hose assembly from that supplied with the unit or attempt to use a Type 1 equipped regulator/hose assembly with a standard 510 POL tank/valve assembly. The cylinder must be provided with a shut-off valve terminating in an LP gas supply cylinder valve outlet specified, as applicable, for connection Type 1.
- If the appliance is stored indoors, the cylinder must be disconnected and removed from the appliance.
- Cylinders must be stored outdoors in a well ventilated area out of the reach of children.
- Gas cylinder supply must be turned off when not in use.

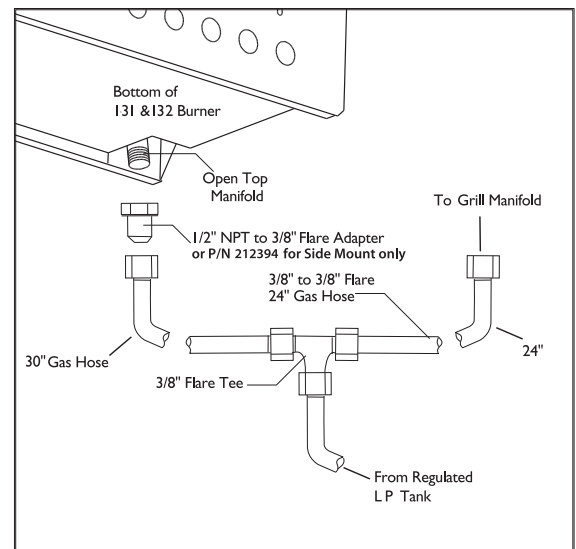

FIG. 05 LP Gas

INSTALLATION

LEAK TESTING

WARNING!

Do not smoke while leak testing. Extinguish all open flames.

Make a soap solution of one part liquid detergent, and one part water. Never test for leaks with an open flame. For LP units, check with a full cylinder. Make sure all control valves are in the "OFF" position. Turn the gas supply "ON". Check all connections from the supply line (Fig. 04), or LP cylinder (Fig. 05) up to the manifold pipe assembly (Fig. 06). Apply the soap solution around the connection with a spray bottle, brush, or rag. Soap bubbles will appear where leak is present. If a leak is present, turn off gas supply, tighten any leaking fittings, turn gas on, and recheck.

WARNING: IMPORTANT!

Inspect the gas supply piping or hose prior to turning the gas "ON". If there is evidence of cuts, wear or abrasion, it must be replaced prior to use. Do not use the side burner if the odor of gas is present. Turn the control knob to "OFF", then turn off the gas supply. If using LP, is there gas in the tank? Always keep your face and body as far away from the burner as possible when lighting.

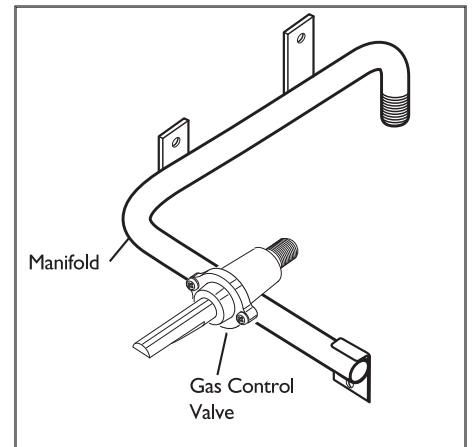

FIG. 06

BURNER ADJUSTMENT

BURNERS

Your new side burner is equipped with burners typical of those used in restaurants (Fig. 07). These burners are designed for maximum cleanability and controllability. The burner should never be operated if the cap is not in place.

BURNER EFFICIENCY AND FLAME CHARACTERISTICS

It is necessary to keep the burner ports and the igniters clean for proper lighting and efficient performance of the burners. The burner flame should burn completely around the burner with no excessive noise or lifting. The flame should be blue in color and stable with no yellow tips. During initial use, foreign particles in the gas line, or dust in the air around the appliance may cause an orange flame. This will disappear with use.

FLAME HEIGHT

The correct height of the flame mainly depends on the size of the bottom of the cooking utensil, the material of the cooking utensil, the amount and type of food and the amount of liquid in the utensil. The following are some basic rules for selecting flame height.

- For safety reasons the flame must never extend beyond the bottom of the cooking utensil. Never allow flames to curl up the side of the pan (see Fig.08).
- Utensils which conduct heat slowly (such as glass-ceramic) should be used with medium to low flames. If you are cooking with a large amount of liquid, a slightly larger flame can be used.

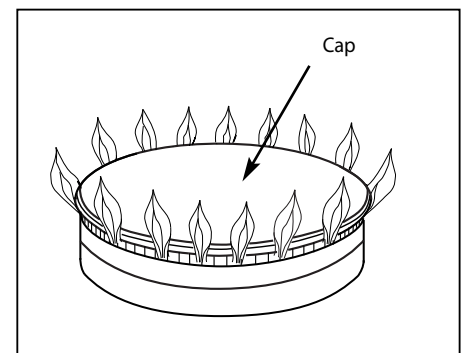

FIG. 07

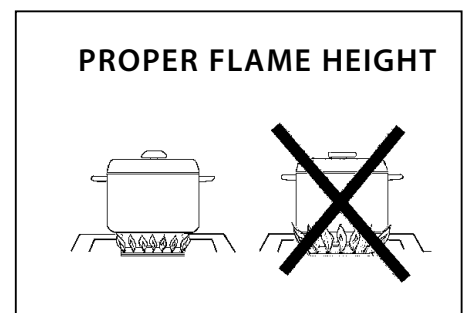

FIG. 08

INSTALLATION

INSTALLER CHECKLIST

- Specified clearances maintained to combustibles.
- Side burner is properly mounted.
- All internal packaging removed.
- Burner is seated properly and does not rock.
- Each burner lights satisfactorily, individually or with adjacent burner lit.
- Knob(s) turn freely. Bezel(s) centered.
- Flame adjusted.
- Pressure regulator connected and set for 4.0"W.C. Natural, 11.2"W.C. LP gas.
- Manual shut-off valve installed and accessible.
- Unit tested and free of leaks.
- User informed of gas supply shut-off valve location.
- Battery installed in module properly and generates ignition spark when activated.

PLEASE LEAVE THESE INSTRUCTIONS WITH THE USER.

USER, PLEASE RETAIN THESE INSTRUCTIONS FOR FUTURE REFERENCE.

USING THE SIDE BURNER

LIGHTING INSTRUCTIONS

First remove the burner cover and any cooking utensils from the burner grate. Push and hold the ignition button, turn the control knob to the "HI" position until the burner is lit or 4 seconds pass. If the burner doesn't ignite, wait 5 minutes for any accumulated gas to dissipate then try again. If the burner will not light after several attempts, check the troubleshooting instructions on page 16.

MATCH LIGHTING

Hold a lit fireplace match near the burner ports, turn the control knob counterclockwise to "HI". Rotate the knob immediately once the burner is lit to the desired setting.

Note:

If you are using propane gas, a slight pop or flash may occur at the burner ports a few seconds after the burner has been turned "off". This "extinction pop" is normal for propane gas.

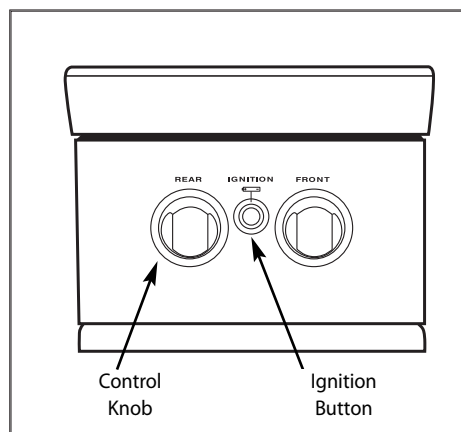

FIG. 09 BGB132 Shown

CARE AND MAINTENANCE

The side burner will give you years of trouble free service if properly maintained. The body panels and front valve panel and burner hanger are made from non-rusting high grade stainless steel. The burner is heavy duty cast iron and brass. The venturi tube is brass.

STAINLESS STEEL

There are many different stainless steel cleaners available. Always use the mildest cleaning procedure first, scrubbing in the direction of the grain. Do not use steel wool as it will scratch the surface. To touch up noticeable scratches in the stainless steel, sand very lightly with Bear-Text (p/n 25032).

SIDE BURNER GRATE

The side burner grate is porcelain enamel over cast iron for durability. To avoid burns, do not clean a hot grate. They may be wiped while in place with hot, soapy water, rinsed and wiped dry thoroughly. Never immerse a hot grate in water. Due to rapid temperature changes the porcelain may pop off the edges of the grates. If the grates develop chips, do not be concerned as the base metal, cast iron, soon darkens to blend with the porcelain enamel. Use care when wiping areas where the enamel has popped off, the edges may be sharp. If cleaning necessitates grate removal, care should be taken in lifting them. They are very heavy. Be sure to place them on a protected surface.

DRIP TRAY

A stainless steel aeration pan and drip tray with a stainless steel handle is located under the burner. It collects any boil-overs or spills. Pull forward to remove. Spills should be washed off as soon as possible to prevent baked on soil.

BURNERS

For proper lighting and performance, keep the burners clean. It is necessary to clean the burners if they do not light even though the igniter clicks, if there has been a severe boil over, or when the flame does not burn blue. Be certain all burner knobs are in the off position before attempting to clean the burners. The burners have been designed for ease of cleaning. When the grate and burners are cool, remove the grate. The burner cap and the brass port ring can easily be lifted off. Wash these parts in hot soapy water, rinse and dry thoroughly. The burner caps are porcelain enamel, follow the directions on the previous page that were given for the burner grates. A bristle brush can be used to clean out the toothed burner ports, if necessary. After cleaning, it is important to make sure the location pins on the bottom side of the port ring are properly aligned with the corresponding holes in the base. Incorrect alignment will produce a potentially dangerous flame and poor burner performance (see Fig. 10).

ELECTRODES

Wipe with a water dampened cotton swab. Be careful not to damage the electrode (see Fig. 11)

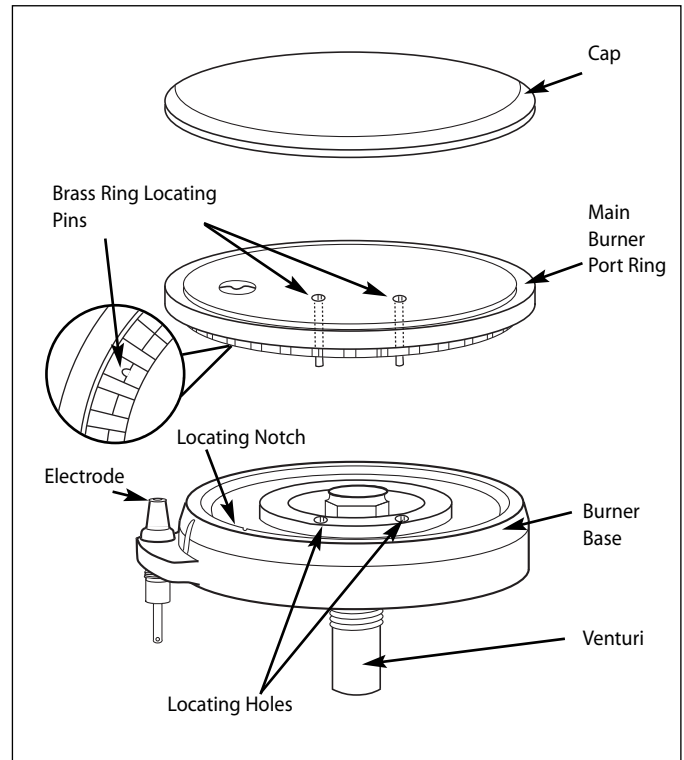

FIG. 10

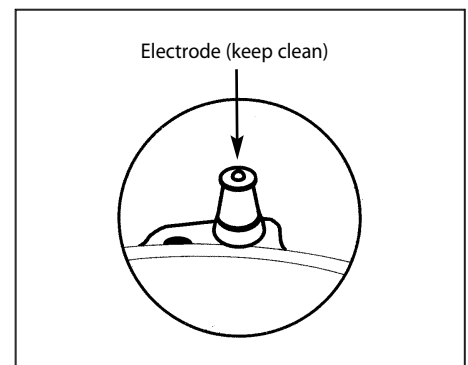

FIG. 11

TROUBLESHOOTING

PROBLEM	WHAT TO DO
<p>Burner won't light when the ignition is pushed.</p>	<p>Remove the burner grate. With the control knob in the "OFF" position, listen to the electrode while engaging the ignition. There should be a spark from the electrode. When the spark jumps, it makes a ticking sound.</p> <p>If there is no spark..... Could be a dead battery. Try replacing the battery.</p> <p>Or the air gap between an electrode tip and a contact metal is too far (gap should be 1/8") or dirty.</p> <p>If there is a spark... is there gas supplied to the unit and is the line purged of air? See Fig. 04 and Fig. 05.</p> <p>Does the other burner of a dual burner model operate?</p> <p>Check the orifice or venturi for blockage.</p>
<p>Burner flame is yellow or orange, in conjunction with the odor of gas.</p>	<p>Check the burner for obstructions or dirt. See page 15.</p> <p>Check for proper gas supply or wrong gas type.</p> <p>Is the side burner in a dusty area? Move to less dusty area if possible.</p>
<p>Low heat with knob in "HI" position.</p>	<p>Is the fuel hose bent or kinked? See Fig. 04 and Fig. 05.</p> <p>Is there adequate gas supply available? If it is only one burner of the dual burner unit that appears low, does the burner need cleaning? See Fig. 10 and Fig. 11.</p> <p>If using LP gas, check for empty tank or low fill level.</p>

PARTS LIST

SINGLE SIDE BURNER - BGB131 & BGB131-BI

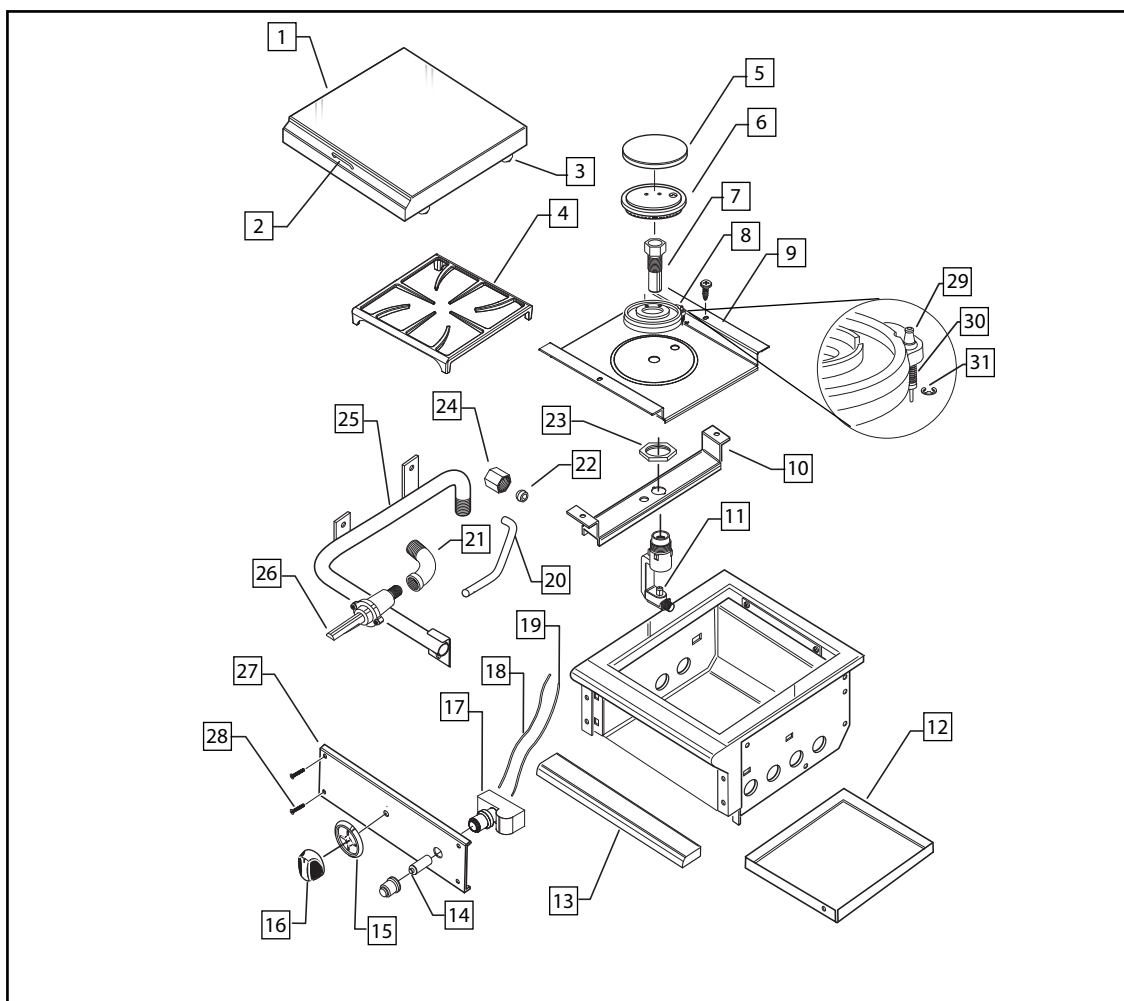

NOTE: Part list typical for BGB131 & BGB131-BI models. Illustration shows BGB131-BI model.

ITEM	DESCRIPTION	PART NO.
1	BURNER COVER	214430
2	PULL HANDLE	212278
3	RUBBER BUMPER	212359
4	TOP GRATE BK	210645
5	D BURNER CAP	210608
6	PORT RING ASSEMBLY	210644
7	VENTURI	210643
8	BASE D BURNER	210639
9	PLATE SUPPORT BURNER	224833
	PLATE SUPPORT BURNER (BGB131-BI)	224930
10	BURNER HANGER	224834
11	JET HOLDER LP	210543
	JET HOLDER NAT	210536
12	DRIP PAN ST. STL (BGA131-BI MODEL)	214165
	DRIP PAN ST. STL (BGB131 MODEL)	224825
13	DRIP PAN HANDLE DBI (BGA131-BI MODEL)	214366
	DRIP PAN HANDLE 131/132 (BGB131 MODEL)	214428
14	1.5VDC BATTERY AA	221154

ITEM	DESCRIPTION	PART NO.
15	BEZEL	210935
16	CONTROL KNOB	211188
17	IGNITION MODULE	211872
18	WIRE BLACK W/ TERMINALS 8"	211823
19	WIRE BLACK W/ TERMINALS 10"	211826
20	TUBING 1/16" (9" LENGTH)	212399
21	ELBOW 1/8NPT X 5/16 T.O.D.	212396
22	FERRULE 5/16	212313
23	NUT M22 JET HOLDER	210468
24	NUT 1/2-24UNF	212312
25	MANIFOLD (BGB131-BI MODEL)	212297
	MANIFOLD (BGB131 MODEL)	221924
26	MANUAL GAS VALVE	220575
27	VALVE PANEL (BGA131-BI MODEL)	224854
	VALVE PANEL (BGB131 MODEL)	224839
28	VALVE PANEL SCREWS (BGB131-B1)	211300
29	ELECTRODE	210562
30	SPRING ELECTRODE	210577
31	CLIP ELECTRODE	210578

PARTS LIST

DOUBLE SIDE BURNER - BGB132 & BGB132-BI

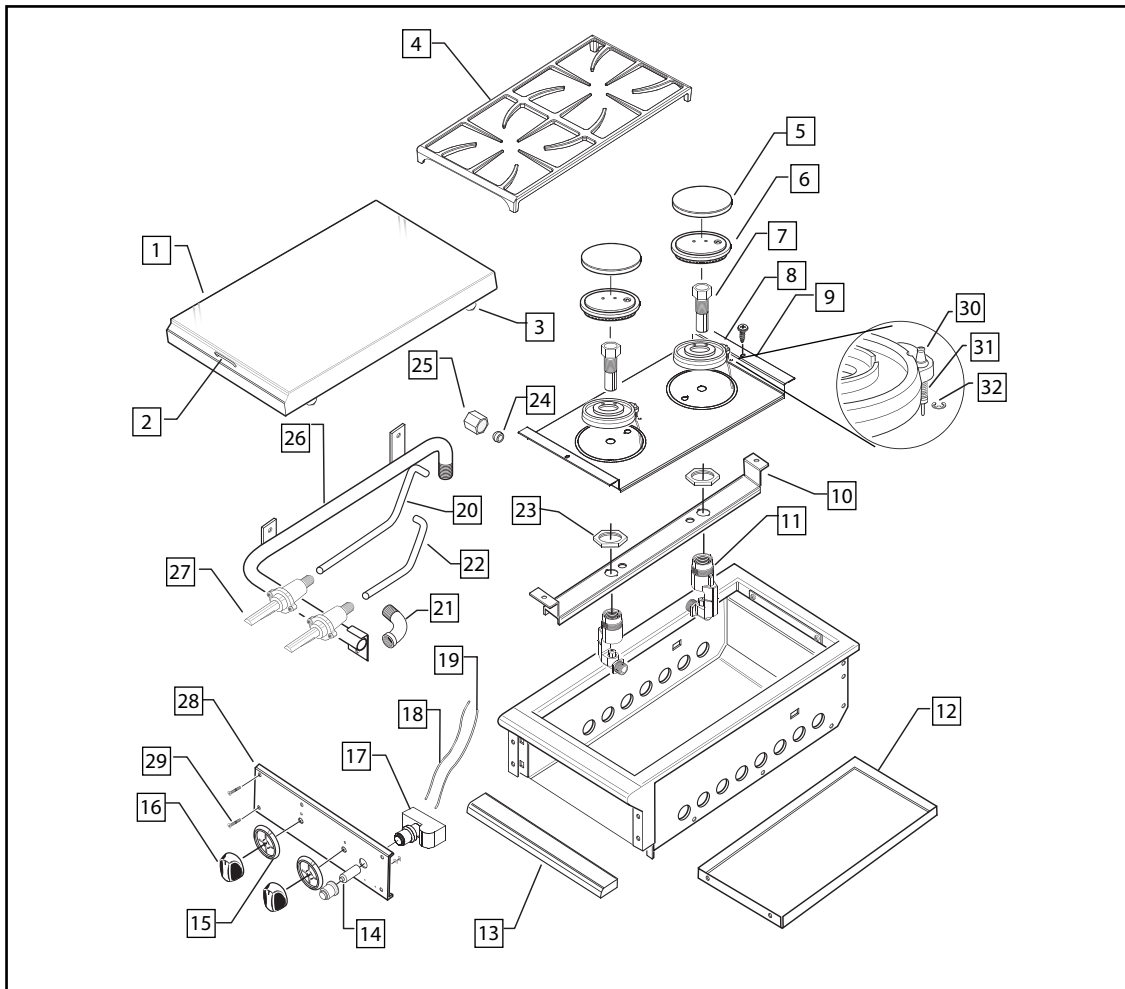

NOTE: Part list typical for BGB132 & BGB132-BI models. Illustration shows BGB132-BI model.

ITEM	DESCRIPTION	PART NO.	ITEM	DESCRIPTION	PART NO.
1	BURNER COVER	214425	16	CONTROL KNOB	211188
2	PULL HANDLE	212278	17	IGNITION MODULE	211872
3	RUBBER BUMPER	212359	18	WIRE BLACK W/ TERMINALS 10"	211826
4	TOP GRATE BK	220496	19	WIRE BLACK W/ TERMINALS 18"	221058
5	D BURNER CAP	210608	20	TUBING 5/16" (21" LENGTH)	221956
6	PORT RING ASSEMBLY	210644	21	ELBOW 1/8NPT X 5/16 T.O.D.	212396
7	VENTURI	210643	22	TUBING 5/16" (9" LENGTH)	212399
8	BASE D BURNER	210639	23	NUT M22 JET HOLDER	210468
9	PLATE SUPPORT BURNER	214424	24	FERRULE 5/16	212313
	PLATE SUPPORT BURNER (BGB132-BI)	224931	25	NUT 1/2-24UNF	212312
10	BURNER HANGER (BGB132 MODEL)	224817	26	MANIFOLD (BGB132-BI MODEL)	212296
11	JET HOLDER LP	210543		MANIFOLD (BGB132 MODEL)	212387
	JET HOLDER NAT	210536	27	MANUAL GAS VALVE	220575
12	DRIP PAN ST. STL (BGA132-BI MODEL)	214164	28	VALVE PANEL (BGA132-BI MODEL)	214436
	DRIP PAN ST. STL (BGB132 MODEL)	214427		VALVE PANEL (BGB132 MODEL)	214426
13	DRIP PAN HANDLE (BGA132-BI MODEL)	214366	29	VALVE PANEL SCREWS (BGB132-B1)	211300
	DRIP PAN HANDLE 131/132 (BGB132 MODEL)	214428	30	ELECTRODE	210562
14	1.5VDC BATTERY AA	221154	31	SPRING ELECTRODE	210577
15	BEZEL	210935	32	CLIP ELECTRODE	210578

WIRING DIAGRAM

SINGLE & DOUBLE SIDE BURNER

SINGLE SIDE BURNER

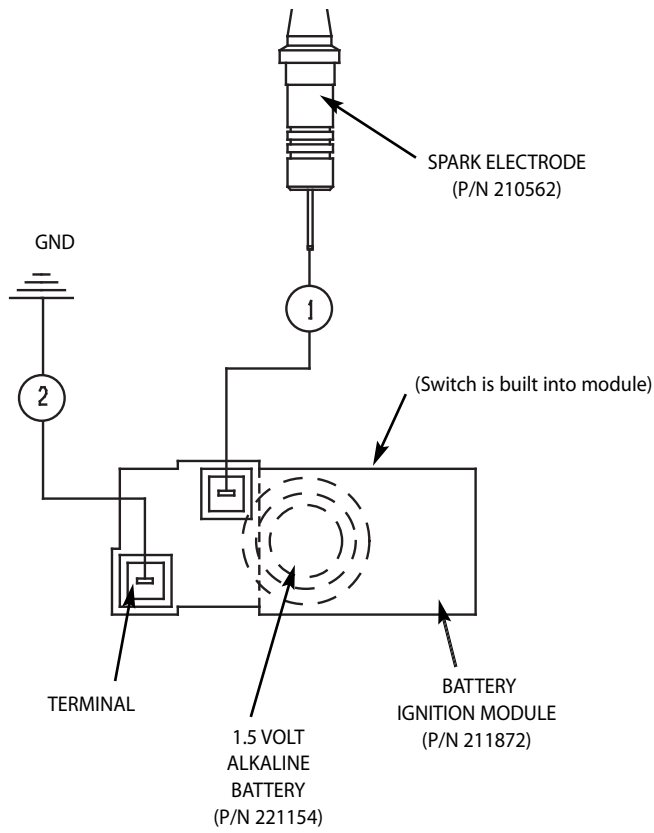

DOUBLE SIDE BURNER

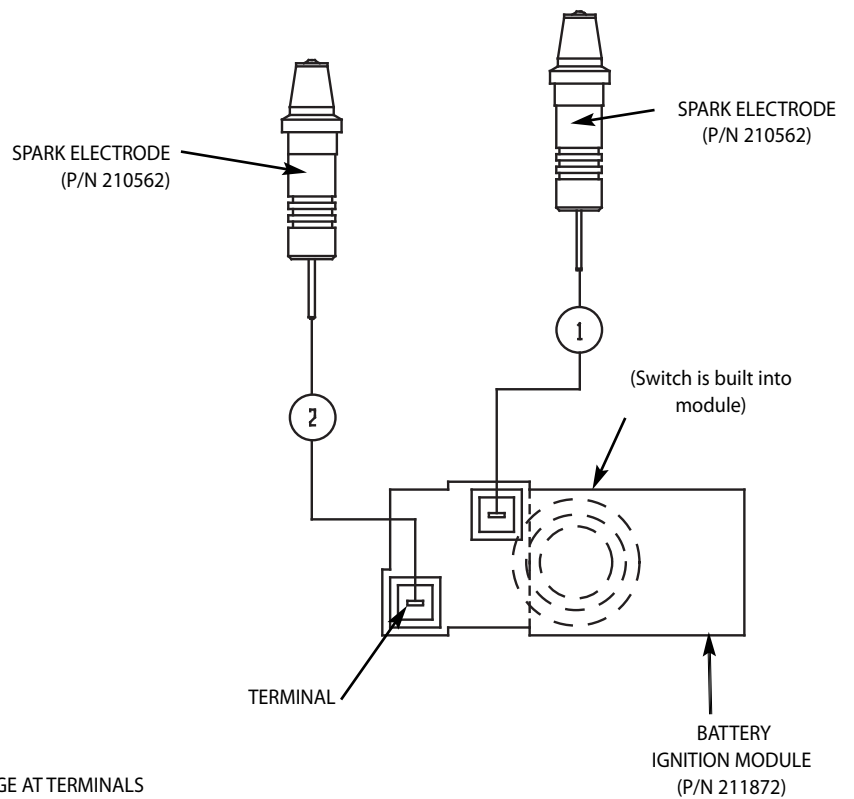

NOTE: HIGH VOLTAGE AT TERMINALS

SERVICE

HOW TO OBTAIN SERVICE:

For warranty service, please contact your local service provider or DCS Customer Care at (888) 936-7872. Before you call, please have the following information ready:

- Model Number (located on the inside of the left side of the appliance)
- Serial Number (located on the inside of the left side of the appliance)
- Code (located on the inside of the left side of the appliance)
- Gas Type
- Date of installation
- A brief description of the problem

Your satisfaction is of the utmost importance to us. If a problem cannot be resolved to your satisfaction, please write or email us at:

Write:

Fisher & Paykel Appliances, Inc.
Attention: DCS Customer Care
5900 Skylab Road
Huntington Beach, CA 92647

Email: customer.care@fisherpaykel.com

BEFORE YOU CALL FOR SERVICE:

1. Check troubleshooting on page 16.
2. Is the gas turned on?
3. Is there a dead battery in the ignition module?

WARRANTY

LIMITED WARRANTY

When you purchase a new DCS Side Burner, you automatically receive a One Year Limited Warranty covering parts and labor for the entire product, and a Five Year Limited Warranty on the structural integrity of the exterior and interior body parts for servicing within the 48 mainland United States, Hawaii, Washington D.C. and Canada. In Alaska, the Limited Warranty is the same except that you must pay to ship the Product to the service shop or the service technician's travel to your home. Products for use in Canada must be purchased through the Canadian distribution channel to ensure regulatory compliance. Should corrosion occur to the degree of non-performance, replacement parts will be furnished. This does not apply if the unit was subjected to other than normal residential use.

FISHER & PAYKEL UNDERTAKES TO:

Repair without cost to the owner either for material or labor any part of the Product, the serial number of which appears on the Product, which is found to be defective. In Alaska, you must pay to ship the Product to the service shop or for the service technician's travel to your home.

If we are unable to repair a defective part of the Product after a reasonable number of attempts, at our option we may replace the part or the Product, or we may provide you a full refund of the purchase price of the Product (not including installation or other charges).

This warranty extends to the original purchaser and any succeeding owner of the Product for products purchased for ordinary single-family home use. All service under this Limited Warranty shall be provided by Fisher & Paykel Appliances Inc. or its Authorized Service Agent during normal business hours.

HOW LONG DOES THIS LIMITED WARRANTY LAST?

Our liability under this Limited Warranty for the entire product expires ONE YEAR from the date of purchase of the Product by the first consumer. Our liability under this Limited Warranty for the structural integrity of the exterior and interior body parts expires FIVE YEARS from the date of purchase of the Product by the first consumer.

Our liability under any implied warranties, including the implied warranty of merchantability (an unwritten warranty that the Product is fit for ordinary use) also expires ONE YEAR (or such longer period as required by applicable law) from the date of purchase of the Product by the first consumer. Some states do not allow limitations on how long an implied warranty lasts, so this limit on implied warranties may not apply to you.

THIS WARRANTY DOES NOT COVER:

- A. Service calls that are not related to any defect in the Product. The cost of a service call will be charged if the problem is not found to be a defect of the Product. For example:
 - 1. Correct faulty installation of the Product.
 - 2. Instruct you how to use the Product.
 - 3. Replace house fuses, reset circuit breakers, correct house wiring or plumbing, or replace light bulbs.
 - 4. Correct fault(s) caused by the user.
 - 5. Change the set-up of the Product.
 - 6. Unauthorized modifications of the Product.
 - 7. Noise or vibration that is considered normal, for example, drain/fan sounds, regeneration noises or user warning beeps.
 - 8. Correcting damage caused by pests, for example, rats, cockroaches etc.
- B. Defects caused by factors other than:
 - 1. Normal domestic use or
 - 2. Use in accordance with the Product's Use and Care Guide.

WARRANTY (continued)

- C. Defects to the Product caused by accident, neglect, misuse, fire, flood or Act of God.
- D. The cost of repairs carried out by non-authorized repairers or the cost of correcting such unauthorized repairs.
- E. Travel Fees and associated charges incurred when the product is installed in a location with limited or restricted access (i.e. airplane flights, ferry charges, isolated geographic areas).
- F. Normal recommended maintenance as set forth in the Product's Use and Care Guide.

If you have an installation problem, contact your dealer or installer. You are responsible for providing adequate electrical, exhausting and other connection facilities. We are not responsible for consequential or incidental damages (the cost of repairing or replacing other property damaged if the Product is defective or any of your expenses caused if the Product is defective). Some states do not allow the exclusion or limitation of incidental or consequential damages, so the above limitation or exclusion may not apply to you.

HOW TO GET SERVICE

Please read your Use and Care Guide. If you then have any questions about operating the Product, need the name of your local DCS Authorized Service Agent, or believe the Product is defective and wish service under this Limited Warranty, please contact your dealer or call us at:

TOLL FREE 1-888-936-7872 or contact us through our web site: www.dcsappliances.com

You may be required to provide reasonable proof of the date of purchase of the Product before the Product will be serviced under this Limited Warranty.

COMMERCIAL USE

This warranty applies to appliances used in residential applications; it does not cover their use in commercial situations.

NO OTHER WARRANTIES

This Limited Warranty is the complete and exclusive agreement between you and Fisher & Paykel Appliances Inc. regarding any defect in the Product. None of our employees (or our Authorized Service Agents) are authorized to make any addition or modification to this Limited Warranty.

Warrantor: Fisher & Paykel Appliances, Inc.

If you need further help concerning this Limited Warranty, please call us at the above number, or write to:

Fisher & Paykel Appliances, Inc.
Attention: DCS Customer Care
5900 Skylab Road, Huntington Beach, CA 92647

This Limited Warranty gives you specific legal rights, and you may also have other rights which vary from state to state.

Fisher & Paykel Appliances Inc. is a leading manufacturer of premium quality cooking and specialty appliances under the Fisher & Paykel and DCS brands.