

This Owner's Manual is provided and hosted by [Appliance Factory Parts](#).



FISHER & PAYKEL WDTI Owner's Manual

[Shop genuine replacement parts for FISHER & PAYKEL
WDTI](#)



[Find Your FISHER & PAYKEL HVAC Parts - Select From 16 Models](#)

----- Manual continues below -----



THE PROFESSIONAL WARMING DRAWER

Installation Guide



MODELS:

WDT-30

WDTI



A MESSAGE TO OUR CUSTOMERS

Thank you for selecting this DCS Warming Drawer. Because of its unique features, we have developed this Installation Guide. It contains valuable information on how to properly install your new Warming Drawer for years of safe and enjoyable use.

For your convenience, product questions can be answered by a DCS Customer Care Representative by phone:1-888-936-7872, or email: customer.care@fisherpaykel.com.

NOTE: Please write the Model, Code, and Serial Numbers on this page for references (located at the front right hand side of the body of the drawer).

MODEL NUMBER _____ CODE _____ SERIAL NUMBER _____

NOTE: Inspect the product to verify that there is no shipping damage. If any damage is detected, call the shipper and initiate a damage claim. DCS by Fisher & Paykel is not responsible for shipping damage.

DO NOT discard any packing material (box, pallet, straps) until the unit has been inspected.

WARNING

The warming drawer is not intended to be used in conjunction with water. **DO NOT** fill the drawer or warming cavity with water. Doing so could create a shock hazard, resulting in a possible injury.

WARNING

TO REDUCE THE RISK OF INJURY TO PERSONS IN THE EVENT OF A WARMING DRAWER GREASE FIRE, OBSERVE THE FOLLOWING: SMOTHER FLAMES with a close-fitting lid, cookie sheet, or metal tray, then turn off the Warming Drawer. **BE CAREFUL TO PREVENT BURNS.** If the flames do not go out immediately **EVACUATE AND CALL THE FIRE DEPARTMENT. NEVER PICK UP A FLAMING PAN** - You may be burned. **DO NOT USE WATER**, including wet dishcloths or towels - a violent steam explosion will result. Use an extinguisher **ONLY** if:

1. You know you have a Class ABC extinguisher, and you already know how to operate it.
2. The fire is small and contained in the area where it started.
3. The fire department is being called.
4. You can fight the fire with your back to an exit.

WARNING

DO NOT use water on grease fires. Turn **OFF** the warming drawer, then smother the fire with baking soda or use a dry chemical or foam-type fire extinguisher.

PLEASE RETAIN THIS MANUAL FOR FUTURE REFERENCE.

TABLE OF CONTENTS

SAFETY PRACTICES & PRECAUTIONS	3-4
FEATURES	5
INSTALLATION INSTRUCTIONS	
Specifications	6
Mounting Installation	7-8
Custom Panel Installation (WDTI)	9
Cabinet Installation	10
SERVICE	11
WARRANTY	12-13

SAFETY PRACTICES AND PRECAUTIONS

READ AND UNDERSTAND THESE PRECAUTIONS

- Read this Installation Guide thoroughly before installation. This will help to reduce the risk of fire, electric shock, or injury to persons.
- Remove all packaging materials from your appliance.
- Install according to instructions. See page 6-10 to insure proper installation and servicing.
- Be sure to have a qualified service technician install and ground this appliance.
- Plug into rated outlet: 120 Volts AC, 5 amp min., 15 amp maximum circuit requirement.

PREHEATING INSTRUCTIONS

The Warming Drawer is designed to keep cooked foods warm for extended periods of time. The drawer must be pre-heated before use on high (see Use and Care Guide). If the warming drawer isn't pre-heated, the internal temperature of the food being warmed could fall below the minimum safe level and bacteria could develop. Always preheat the drawer according to the instructions described in the warming drawer Use and Care Guide.

- Children should not be left alone or unattended in an area where appliances are in use. They should never be allowed to turn knobs, push buttons, sit or stand on any part of an appliance.
- Children in walkers, or children crawling can be attracted to the round door handle and may grab and open the warming drawer. This can result in injury from the door being pulled open on a child, or severe burns if it is in use and hot.



WARNING:

Do not store items of interest to children in, above or around any appliance. Children could be seriously injured if they should climb onto the appliance to reach these items.

Be certain to use only dry pot holders: Moist or damp pot holders on hot surfaces may cause burns from steam. Do not use a towel or other bulky cloth in place of pot holders.

- Never store anything in the warming drawer. Flammable materials can catch fire, plastic items may melt or ignite and other types of items could be ruined.
- Do not hang articles from any part of the appliance or place anything against the drawer. Some fabrics are quite flammable and could catch on fire.
- For safety reasons and to avoid damage to the appliance, never sit, stand, or lean on the warming drawer door.
- For personal safety, wear proper apparel. Loose fitting garments or hanging sleeves should never be worn while using this appliance. Some synthetic fabrics are highly flammable and should not be worn while using this appliance.
- Do not use aluminum foil to line any part of the warming drawer. Using a foil liner could result in a fire hazard, or the obstruction of the flow of heat and ventilation air. Foil is an excellent heat insulator and heat will be trapped underneath it. This trapped heat can upset the performance of the warming drawer parts.



WARNING:

This appliance is designed for warming food. Based on safety considerations, never use the warming drawer to warm or heat a room.

- As with any cooking or heating appliance, never leave the warming drawer unattended when warming food, this could be a fire hazard.
- Only certain types of glass, heat proof glass-ceramic, ceramic, earthenware or glazes are suitable for use in this

SAFETY PRACTICES & PRECAUTIONS

warming drawer. Utensils that are not thermally heat safe may break with sudden temperature changes.

- Never heat unopened containers, a build up of pressure may cause the container to burst.
- Grease is flammable, avoid letting grease deposits collect in the warming drawer, clean up spillage.
- 120 Volts AC, 5 amp min., 15 amp maximum circuit requirement.
- DO NOT use water on grease fires. Turn OFF the warming drawer, then smother the fire with baking soda or use a dry chemical or foam-type fire extinguisher.
- When opening the drawer while keeping sauces warm, tomato sauce, etc., the drawer must be opened slowly to avoid spillage.
- Use care when opening a hot warming drawer; to avoid severe burns, open slowly, allow the hot air or steam to escape before reaching in to remove or replace any foods.
- Do not repair or replace any part of this appliance unless it is specifically recommended in this manual. All other servicing should be referred to a qualified Service Technician. Service Technicians must disconnect the power supply before servicing this appliance.
- When using the warming drawer: DO NOT TOUCH THE INTERIOR SURFACES or the exterior area immediately surrounding the door until it has had sufficient time to cool to avoid burn injuries.
- Clean the warming drawer with caution. Avoid steam burns; do not use a wet sponge or cloth to clean the appliance while it is hot. Some cleaners produce noxious fumes if applied to a hot surface. Follow directions provided by the cleaner manufacturer.
- Be sure all the controls are turned off and the appliance is cool before using any type of aerosol cleaner on or around the appliance. The chemical that produces the spraying action could, in the presence of heat, ignite or cause metal parts to corrode.
- Do not touch the heating element or interior surfaces of the warming drawer, even if they appear dark in color. They may still be hot enough to cause burn injury. Allow sufficient time to cool.
- Do not allow flammable materials which may ignite to come in contact with the hot heating element or the interior surface of the warming drawer until the unit has had a sufficient time to cool.

FEATURES

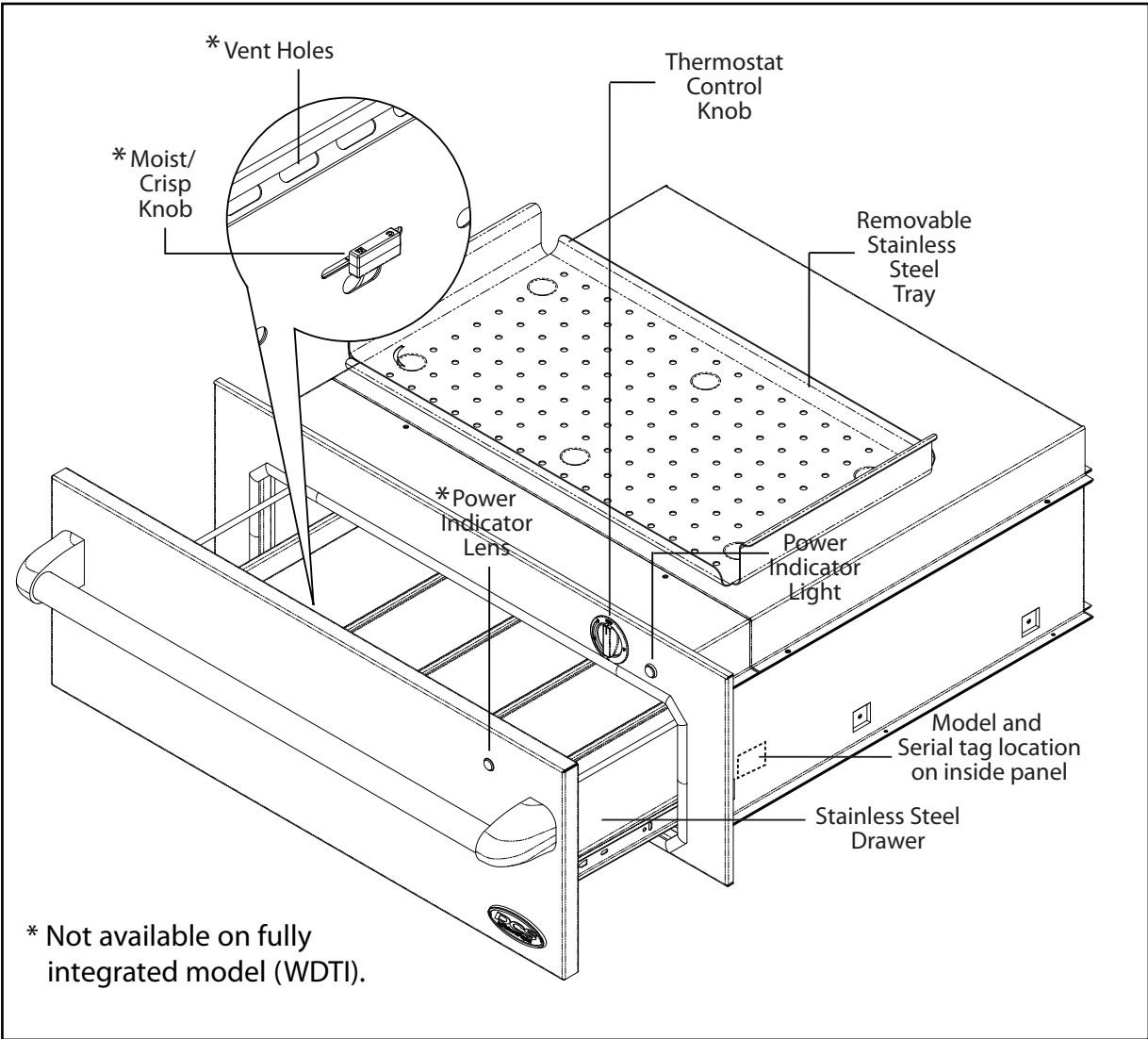

Fig. 01

INSTALLATION INSTRUCTIONS

SPECIFICATIONS

The cabinet depth from the outer edge of the face frame to the inside back of the cabinet or wall should be at least 24" (see Fig. 02).

The Warming Drawer should be installed into a base cabinet with minimum outside dimensions of 13-1/4" high by 30" wide by 24" deep.

Power supply required: 120Volts AC; 5 amp min., 15 amp maximum circuit requirement.

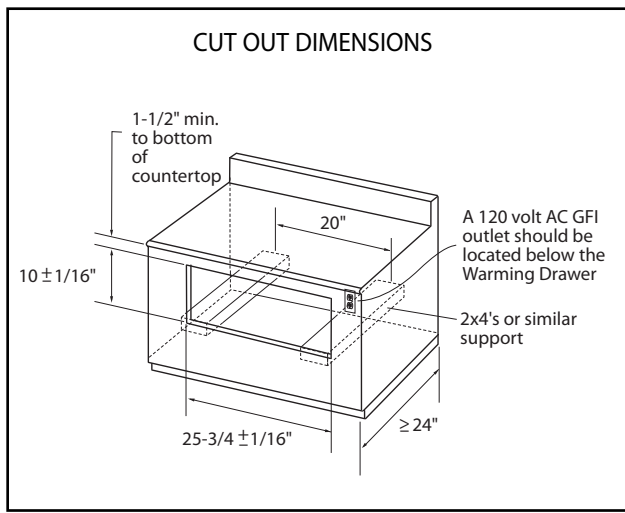

Fig. 02

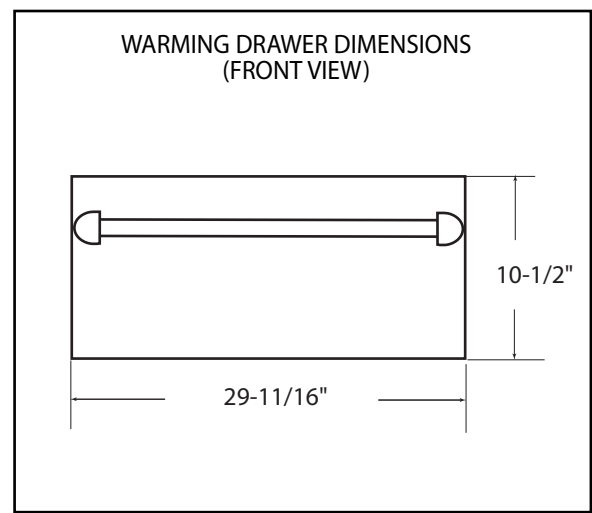

Fig. 03

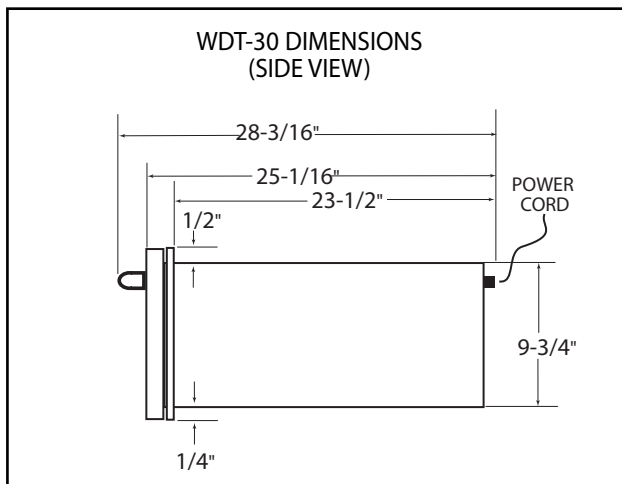

Fig. 04

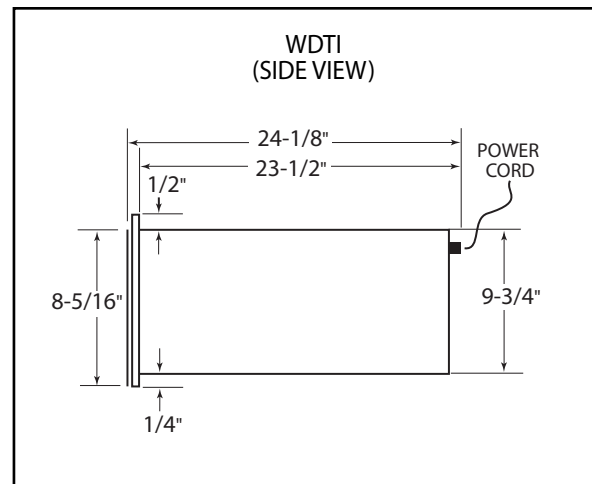

Fig. 05

INSTALLATION INSTRUCTIONS

MOUNTING INSTALLATION

The lower rear corners of the cabinet need to provide proper support to the back of the Warming Drawer and the anti-tip mounting clips. A 120 volt AC outlet should be located no further than 36 inches from the back center of the Warming Drawer.

The bottom rear section of the cabinet should be made of solid plywood or two 2x4 beam. It holds the anti-tip mounting clips and supports the weight of Warming Drawer, which is 90 lbs. (see Fig. 06 and 07). If two 2x4 beams are used, the distance between their centers must be 20" to be able to secure the Warming Drawer.

STEP 1

Use the screws provided and attach the mounting clips. They must be installed for anti-tip safety to the bottom support at the back. See placement dimensions in figure below (see Fig. 06 and 07).

STEP 2

Plug power cord into AC outlet. Slide the body onto the anti-tip mounting clips (see Fig. 07).

STEP 3

Use the two supplied 1-1/2" long screws through the two embossed holes (see Fig. 08) to secure the front of the Warming Drawer.

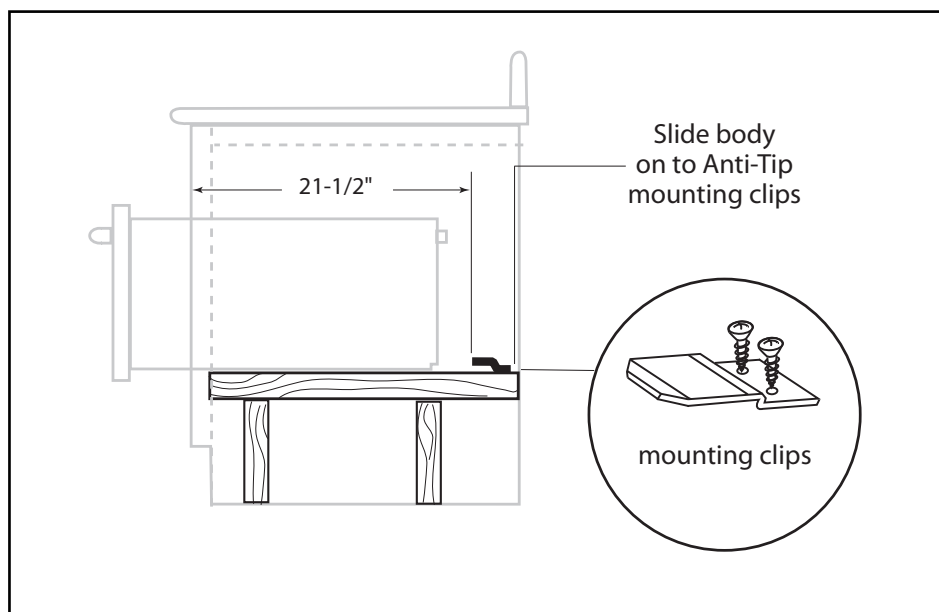

Fig. 06

INSTALLATION INSTRUCTIONS

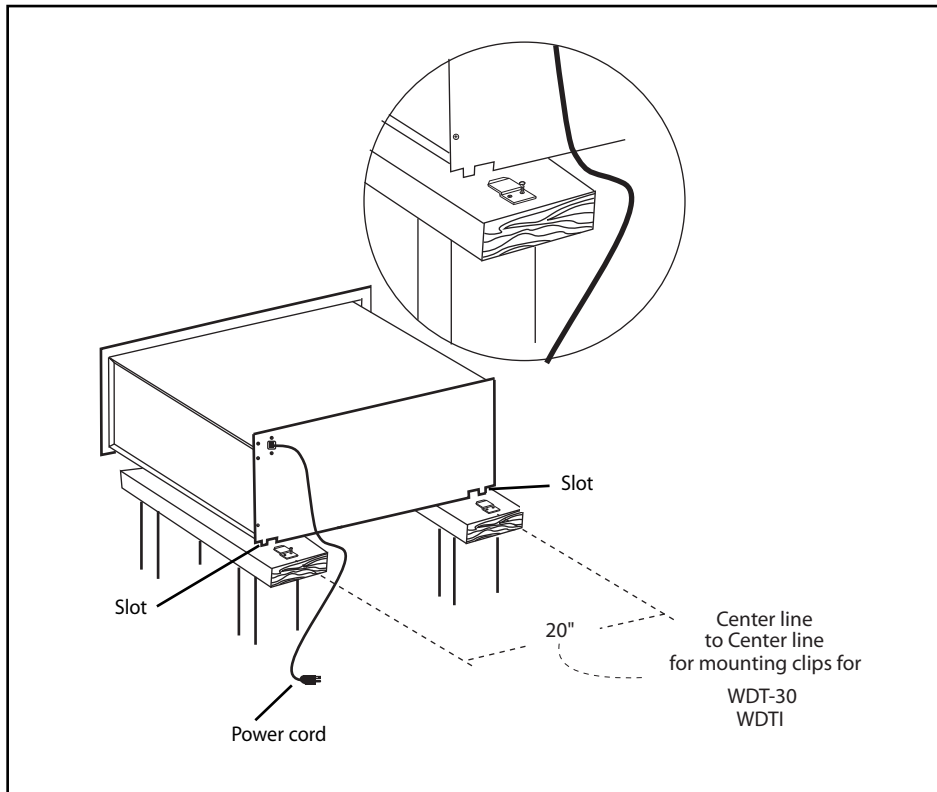

Fig. 07

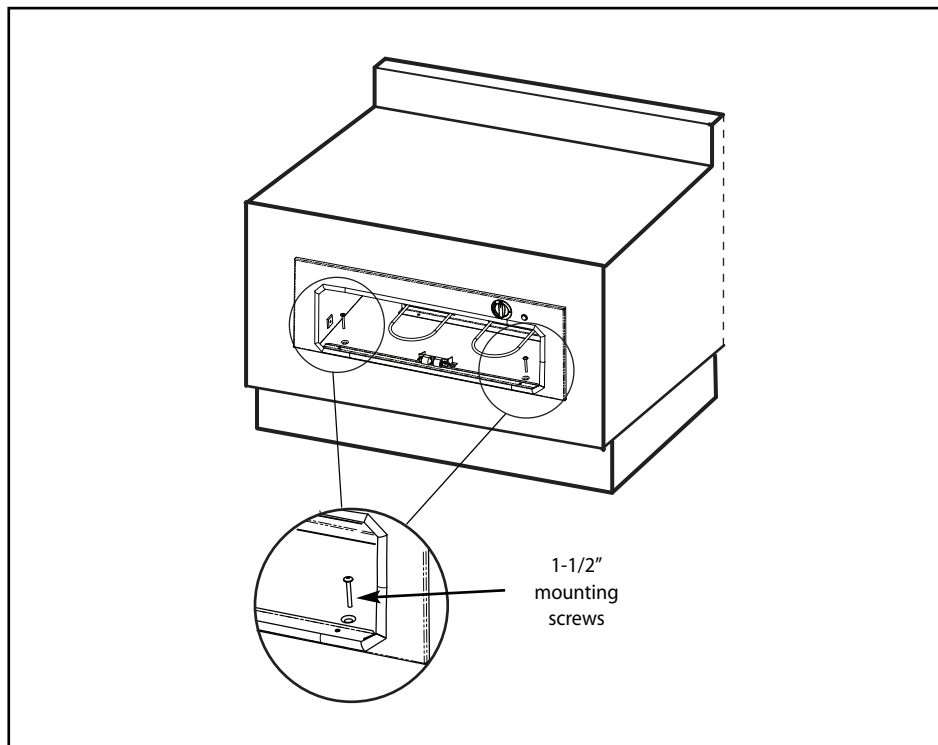

Fig. 08

INSTALLATION INSTRUCTIONS

CUSTOM PANEL INSTALLATION OF THE WARMING DRAWER INTEGRATED (WDTI)

STEP 1

Remove drawer as per instructions (see Use & Care Manual).

STEP 2

Check the dimensions of the front face (see fig. 09).

STEP 3

Cut the custom panel to the desired dimensions, knowing that the panel must cover the paper front template plus 1/8" on all four sides for a good presentation. The thickness of the custom panel must be greater than 9/16" to allow for clearance for the tips of the screws holding the drawer when the custom panel is mounted.

STEP 4

Center the provided paper front template on the back of the custom panel to drill or cut the clearance areas for the hardware holding the drawer. (Note: the drill sizes and callouts are on the template.)

STEP 5

Fasten the custom panel to the front face with the supplied screws as shown in fig. 09.

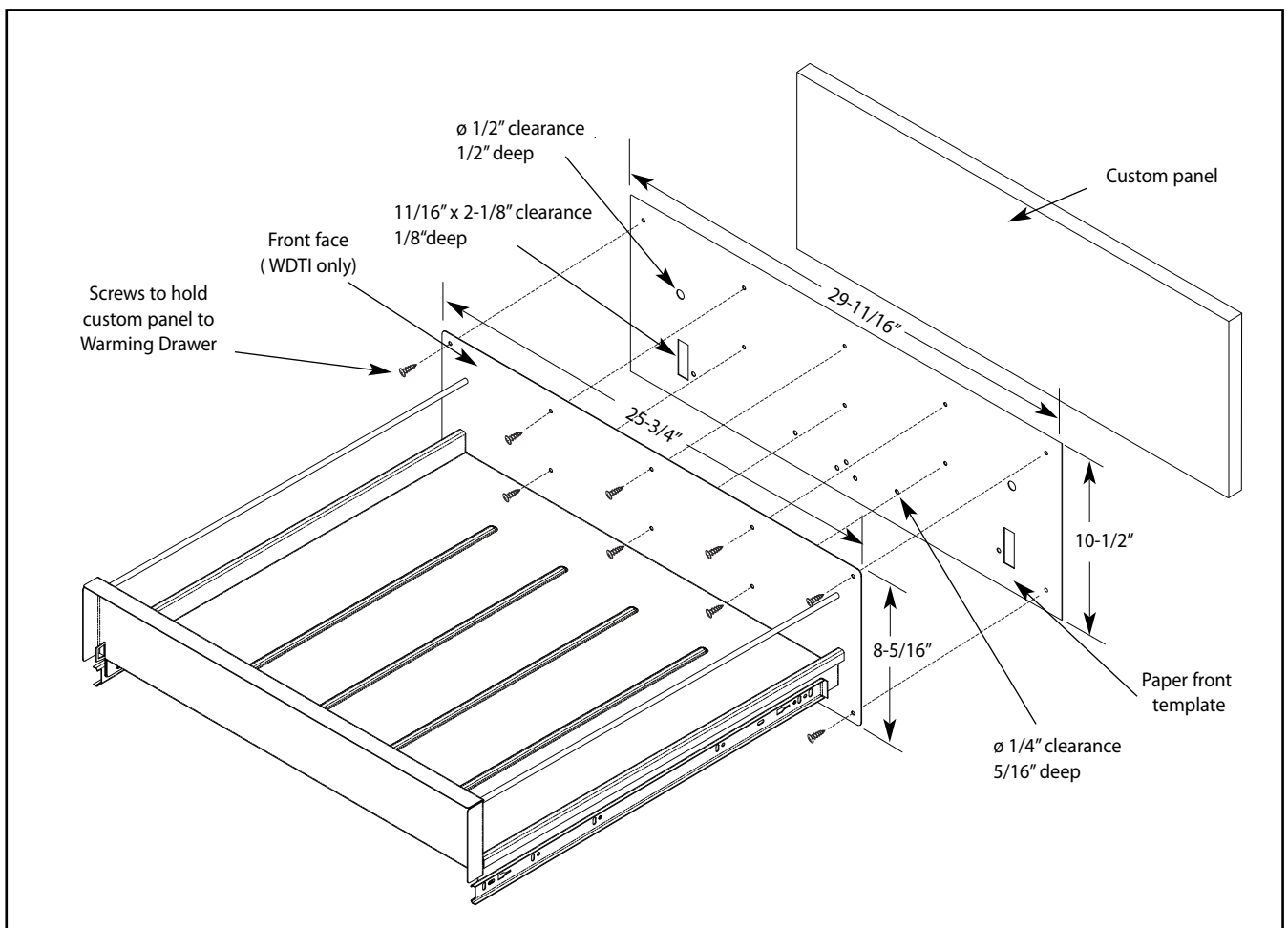

Fig. 09

INSTALLATION INSTRUCTIONS

CABINET INSTALLATION

DOUBLE Wall Oven and Warming Drawer Installation

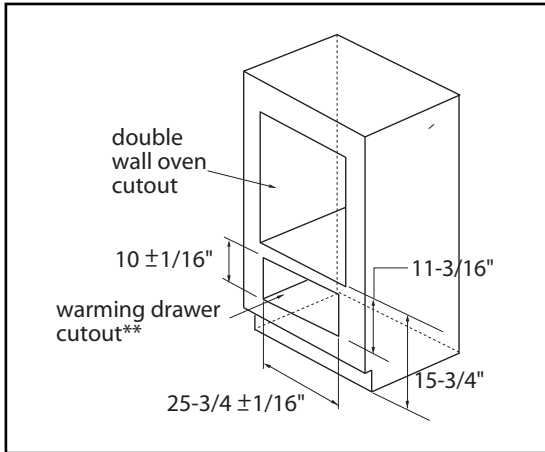

Fig. 10

SINGLE Wall Oven and Microwave and Warming Drawer Installation

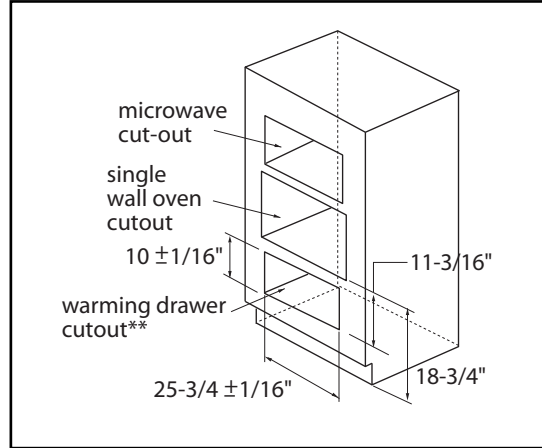

Fig. 11

**The floor of the opening should be constructed of plywood strong enough to support the weight of the oven (or use 2x4 constructions - see fig. 02)

HOW TO OBTAIN SERVICE

HOW TO OBTAIN SERVICE:

Before you call for service:

1. Is the circuit breaker tripped or the fuse blown?
2. Is there a power outage in the area?

For warranty service, please contact your local service provider or DCS Customer Care Representative at (888) 936-7872. Before you call, please have the following information ready:

- Model Number (located at the front right hand side of the body of the drawer)
- Serial Number (located at the front right hand side of the body of the drawer)
- Code (located at the front right hand side of the body of the drawer)
- Date of installation
- A brief description of the problem

Your satisfaction is of the utmost importance to us. If a problem cannot be resolved to your satisfaction, please write to Customer Care or email: customer.care@fisherpaykel.com

Write:

Fisher & Paykel Appliances, Inc.
Attention: DCS Customer Care
5900 Skylab Road
Huntington Beach, CA 92647

WARRANTY

LIMITED WARRANTY

When you purchase a new DCS Professional Warming Drawer you automatically receive a One Year Limited Warranty covering parts and labor for the entire product for servicing within the 48 mainland United States, Hawaii, Washington D.C. and Canada. In Alaska the Limited Warranty is the same except that you must pay to ship the Product to the service shop or the service technician's travel to your home. Products for use in Canada must be purchased through the Canadian distribution channel to ensure regulatory compliance.

FISHER & PAYKEL UNDERTAKES TO:

Repair without cost to the owner either for material or labor any part of the Product, the serial number of which appears on the Product, which is found to be defective. In Alaska, you must pay to ship the Product to the service shop or for the service technician's travel to your home.

If we are unable to repair a defective part of the Product after a reasonable number of attempts, at our option we may replace the part or the Product, or we may provide you a full refund of the purchase price of the Product (not including installation or other charges).

This warranty extends to the original purchaser and any succeeding owner of the Product for products purchased for ordinary single-family home use. All service under this Limited Warranty shall be provided by Fisher & Paykel Appliances Inc. or its Authorized DCS Service Agent during normal business hours.

HOW LONG DOES THIS LIMITED WARRANTY LAST?

Our liability under this Limited Warranty for the entire product expires One Year from the date of purchase of the Product by the first consumer.

Our liability under any implied warranties, including the implied warranty of merchantability (an unwritten warranty that the Product is fit for ordinary use) also expires One Year (or such longer period as required by applicable law) from the date of purchase of the Product by the first consumer. Some states do not allow limitations on how long an implied warranty lasts, so this limit on implied warranties may not apply to you.

THIS WARRANTY DOES NOT COVER:

- A. Service calls that are not related to any defect in the Product. The cost of a service call will be charged if the problem is not found to be a defect of the Product. For example:
 1. Correct faulty installation of the Product.
 2. Instruct you how to use the Product.
 3. Replace house fuses, reset circuit breakers, correct house wiring or plumbing, or replace light bulbs.
 4. Correct fault(s) caused by the user.
 5. Change the set-up of the Product.
 6. Unauthorized modifications of the Product.
 7. Noise or vibration that is considered normal, for example, drain/fan sounds, regeneration noises or user warning beeps.
 8. Correcting damage caused by pests, for example, rats, cockroaches etc.

WARRANTY

- B. Defects caused by factors other than:
 - 1. Normal domestic use or
 - 2. Use in accordance with the Product's Use and Care Guide.
- C. Defects to the Product caused by accident, neglect, misuse, fire, flood or Act of God.
- D. The cost of repairs carried out by non-authorized repairers or the cost of correcting such unauthorized repairs.
- E. Travel Fees and associated charges incurred when the product is installed in a location with limited or restricted access. (i.e. airplane flights, ferry charges, isolated geographic areas).
- F. Normal recommended maintenance as set forth in the Product's Use and Care Guide.

If you have an installation problem, contact your dealer or installer. You are responsible for providing adequate electrical, exhausting and other connection facilities.

We are not responsible for consequential or incidental damages (the cost of repairing or replacing other property damaged if the Product is defective or any of your expenses caused if the Product is defective). Some states do not allow the exclusion or limitation of incidental or consequential damages, so the above limitation or exclusion may not apply to you.

HOW TO GET SERVICE

Please read your Use and Care Guide. If you then have any questions about operating the Product, need the name of your local DCS Authorized Service Agent, or believe the Product is defective and wish service under this Limited Warranty, please contact your dealer or call us at:

TOLL FREE 1-888-936-7872 or contact us through our web site: www.dcsappliances.com

You may be required to provide reasonable proof of the date of purchase of the Product before the Product will be serviced under this Limited Warranty.

COMMERCIAL USE

This warranty applies to appliances used in residential applications; it does not cover their use in commercial situations.

NO OTHER WARRANTIES

This Limited Warranty is the complete and exclusive agreement between you and Fisher & Paykel Appliances Inc. regarding any defect in the Product. None of our employees (or our Authorized Service Agents) are authorized to make any addition or modification to this Limited Warranty.

Warrantor: Fisher & Paykel Appliances, Inc.

If you need further help concerning this Limited Warranty, please call us at the above number, or write to: Fisher & Paykel Appliances, Inc., 5900 Skylab Road, Huntington Beach, CA 92647

This Limited Warranty gives you specific legal rights, and you may also have other rights which vary from state to state.

Fisher & Paykel Appliances Inc. is a leading manufacturer of premium quality cooking and specialty appliances under the Fisher & Paykel and DCS brands.



Quality provided by Fisher & Paykel Appliances Inc.

Fisher & Paykel Appliances, Inc.
5900 Skylab Road, Huntington Beach, CA 92647
Customer Care: 888.936.7872
Fax: 714.372.7003
www.dcsappliances.com

As product improvement is an ongoing process, we reserve the right to change specifications or design without notice.

Nous améliorons constamment ses produits et se réserve le droit de modifier les spécifications ou la conception de ses produits sans aucun préavis.

P/N 241266 Rev. B
Litho in USA 08/2008