

**SHARP®**  
Carousel®

# MICROWAVE Cooking Guide

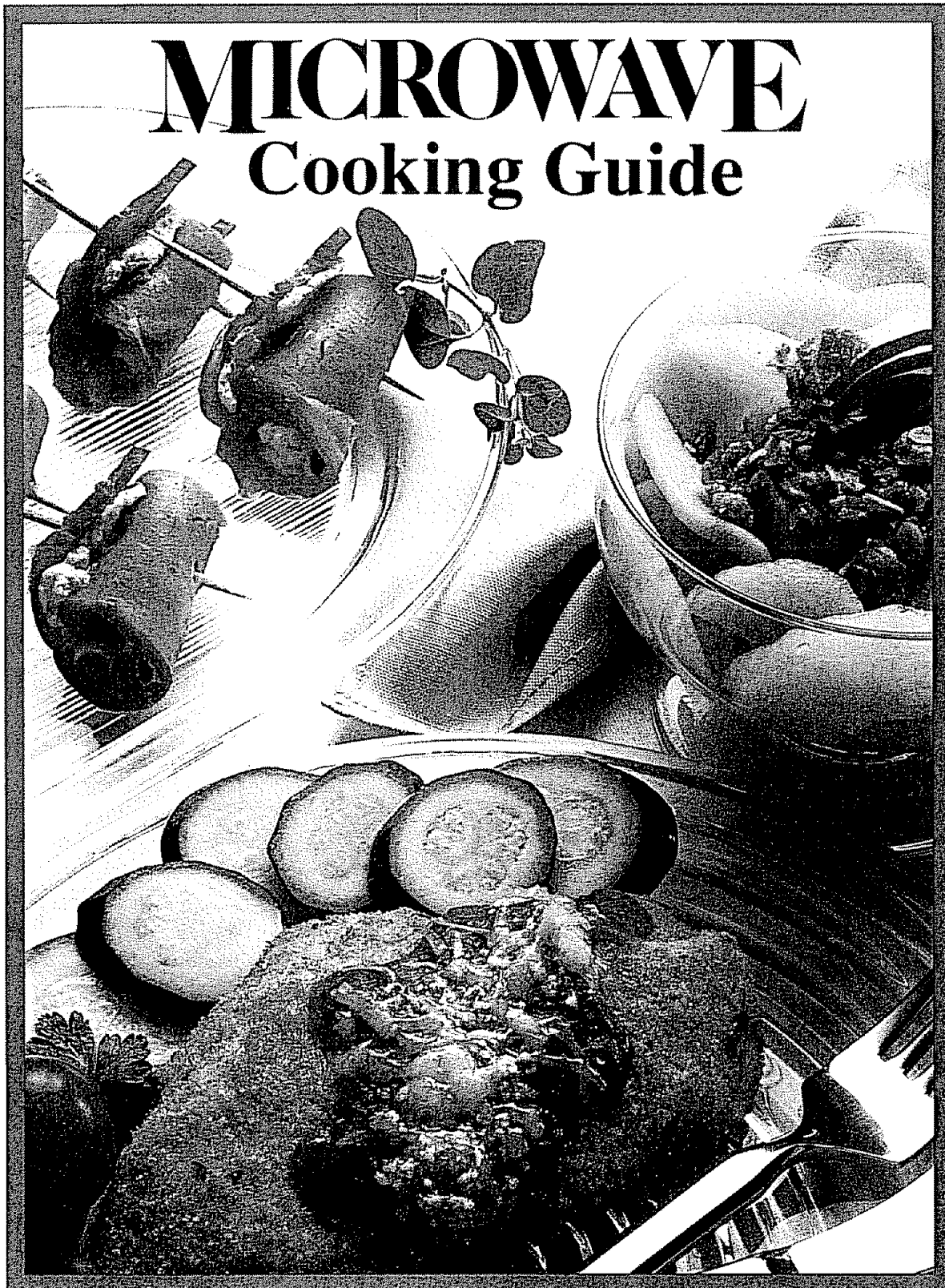

**Models R-1450, R-1451**

Read all instructions carefully before using these ovens.

# PRECAUTIONS TO AVOID POSSIBLE EXPOSURE TO EXCESSIVE MICROWAVE ENERGY

- (a) Do not attempt to operate this oven with the door open since open-door operation can result in harmful exposure to microwave energy. It is important not to defeat or tamper with the safety interlocks.
- (b) Do not place any object between the oven front face and the door or allow soil or cleaner residue to accumulate on sealing surfaces.
- (c) Do not operate the oven if it is damaged. It is particularly important that the oven door close properly and that there is no damage to the: (1) door (bent), (2) hinges and latches (broken or loosened), (3) door seals and sealing surfaces.
- (d) The oven should not be adjusted or repaired by anyone except properly qualified service personnel.

## FOR CUSTOMER ASSISTANCE

To aid in reporting this microwave oven in case of loss or theft, please record below the model number and serial number located on the unit. We also suggest you record all the information listed and retain for future reference.

MODEL NUMBER _____ SERIAL NUMBER _____
DATE OF PURCHASE _____
Dealer _____ Telephone _____
Servicer _____ Telephone _____

### TO PHONE,

DIAL 1-800-BE-SHARP (1-800-237-4277) FOR:  
SERVICE  
(for your nearest Sharp Authorized Servicer)  
PARTS  
(for your authorized parts distributor)  
ACCESSORIES  
ADDITIONAL CUSTOMER INFORMATION

DIAL 201-529-8703 FOR:  
COOKING ASSISTANCE

### TO WRITE:

For cooking and operation questions:

Susan Edwards/Test Kitchen  
Sharp Electronics Corporation  
Sharp Plaza, Box 650  
Mahwah, NJ 07430-2135

For service problems, warranty information, missing items and other assistance:

Sharp Electronics Corporation  
Customer Information Center  
Sharp Plaza, Box 650  
Mahwah, NJ 07430-2135

Please provide the following information when you write or call: model number, serial number, date of purchase, your complete mailing address (including zip code), your daytime telephone number (including area code) and description of the problem.

# CONTENTS

<b>Precautions to Avoid Possible Exposure to Excessive Microwave Energy</b> .....	1	Baked Potatoes.....	13
<b>For Customer Assistance</b> .....	1	Popcorn.....	13
<b>Contents</b> .....	2	Instant Sensor Chart .....	13
<b>Limited Warranty</b> .....	3	Sensor Cook.....	14
<b>Product Information Card</b> .....	3	Sensor Cook Chart.....	14
<b>Important Safety Instructions</b> .....	4	Sensor Cook Recipes.....	15-16
<b>Unpacking Instructions</b> .....	5	CompuDefrost .....	17
<b>Optional Accessories</b> .....	5	CompuDefrost Chart .....	17
<b>Grounding Instructions</b> .....	5	Manual Defrost .....	18
<b>Information You Need to Know</b> .....	6	CompuCook .....	18
About Your Oven .....	6	CompuCook Chart .....	18
About Food.....	6	Minute Plus .....	19
About Microwave Cooking.....	7	Multiple Sequence Cooking.....	19
About Safety.....	7	Minute Timer.....	19
About Utensils and Coverings .....	8	Pause.....	19
About Children and the Microwave .....	8	Auto Start.....	20
<b>Part Names</b> .....	9	Audible Signal Elimination.....	20
<b>Touch Control Panel</b> .....	10	More or Less Time Adjustment.....	20
<b>Before Operating</b> .....	11	Safety Lock.....	20
To Set the Clock .....	11	Demonstration Mode.....	20
Stop/Clear .....	11	<b>Service Call Check</b> .....	21
<b>Manual Operation</b> .....	11	<b>Specifications</b> .....	21
Time Cooking .....	11	<b>Cleaning and Care</b> .....	22-23
Turntable On/Off.....	12	<b>Reheating Chart</b> .....	24
<b>Special Features</b> .....	12	<b>Fish and Seafood Cooking Chart</b> .....	24
Sensor Cooking.....	12	<b>Meat and Poultry Roasting Chart</b> .....	25
Instant Sensors.....	13	<b>Vegetable Cooking Chart</b> .....	26
Frozen Entree .....	13	<b>THE ULTIMATE ACCESSORY</b> .....	27
Sensor Reheat .....	13	<b>AUTO-TOUCH GUIDE</b> .....	Back Cover

## LIMITED WARRANTY

SHARP ELECTRONICS CORPORATION warrants to the first consumer purchaser that this Sharp brand product (the "Product"), when shipped in its original container, will be free from defective workmanship and materials and agrees that it will, at its option, either repair the defect or replace the defective Product or part thereof at no charge to the purchaser for parts or labor for the time period(s) set forth below.

This warranty does not apply to any appearance items of the Product nor to the additional excluded item(s) set forth below nor to any Product the exterior of which has been damaged or defaced, which has been subjected to misuse, abnormal service or handling or which has been altered or modified in design or construction.

In order to enforce the rights under this limited warranty, the purchaser should follow the steps set forth below and provide proof of purchase to the servicer.

The limited warranty described herein is in addition to whatever implied warranties may be granted to purchasers by law. ALL IMPLIED WARRANTIES INCLUDING THE WARRANTIES OF MERCHANTABILITY AND FITNESS FOR USE ARE LIMITED TO THE PERIOD(S) FROM THE DATE OF PURCHASE SET FORTH BELOW. Some states do not allow limitations on how long an implied warranty lasts, so the above limitation may not apply to you.

Neither the sales personnel of the seller nor any other person is authorized to make any warranties other than those described herein or to extend the duration of any warranties beyond the time period described herein on behalf of Sharp.

The warranties described herein shall be the sole and exclusive warranties granted by Sharp and shall be the sole and exclusive remedy available to the purchaser. Correction of defects, in the manner and for the period of time described herein, shall constitute complete fulfillment of all liabilities and responsibilities of Sharp to the purchaser with respect to the Product and shall constitute full satisfaction of all claims, whether based on contract, negligence, strict liability or otherwise. In no event shall Sharp be liable, or in any way responsible, for any damages or defects in the Product which were caused by repairs or attempted repairs performed by anyone other than an authorized servicer. Nor shall Sharp be liable, or in any way responsible, for any incidental or consequential economic or property damage. Some states do not allow the exclusion of incidental or consequential damages, so the above exclusion may not apply to you.

THE WARRANTY GIVES YOU SPECIFIC LEGAL RIGHTS. YOU MAY ALSO HAVE OTHER RIGHTS WHICH VARY FROM STATE TO STATE.

Your Product model number: R-1450 and R-1451 Home Use Carousel Microwave Oven.  
(Be sure to have this information available when you need service for your Product.)

Warranty period for this Product: One (1) year parts and labor in-home service. In-home service: The servicer will come to the unit's location. If it is necessary to remove the unit for repair, the servicer will reinstall the unit at no extra charge. The warranty period continues for an additional six (6) years, for a total of seven (7) years, with respect to the magnetron tube in the Product for parts only. Labor is not provided free of charge for this additional period.

Additional items excluded from warranty coverage: accessories, rubber or plastic parts, the turntable, light bulbs, glass parts or any printed materials.

Where to obtain service: at a Sharp Authorized Servicer or Sharp Authorized Service Dealer located in the United States. To find out the location of the nearest Sharp Authorized Servicer or Dealer, call Sharp tollfree at 1-800-BE-SHARP (1-800-237-4277).

## PRODUCT INFORMATION CARD

The product information card which is on the inside of the microwave oven carton should be completed within ten days of purchase and returned. We will keep it on file and help you access the information in case of loss, damage or theft. This will also enable us to contact you in the unlikely event that any adjustments or modifications are ever required for your oven.

# IMPORTANT SAFETY INSTRUCTIONS

When using electrical appliances basic safety precautions should be followed, including the following:

**WARNING** - To reduce the risk of burns, electric shock, fire, injury to persons or exposure to excessive microwave energy:

1. Read all instructions before using the appliance.
2. Read and follow the specific **"PRECAUTIONS TO AVOID POSSIBLE EXPOSURE TO EXCESSIVE MICROWAVE ENERGY"** on page 1.
3. This appliance must be grounded. Connect only to properly grounded outlet. See **"GROUNDING INSTRUCTIONS"** on page 5.
4. Install or locate this appliance only in accordance with the provided installation instructions.
5. Some products such as whole eggs and sealed containers -- for example, closed glass jars -- may explode and should not be heated in this oven.
6. Use this appliance only for its intended use as described in this manual. Do not use corrosive chemicals or vapors in this appliance. This type of oven is specifically designed to heat, cook or dry food. It is not designed for industrial or laboratory use.
7. As with any appliance, close supervision is necessary when used by children.
8. Do not operate this appliance if it has a damaged cord or plug, if it is not working properly or if it has been damaged or dropped.
9. This appliance should be serviced only by qualified service personnel. Contact nearest Sharp Authorized Servicer or Dealer for examination, repair or adjustment.
10. Do not cover or block any openings on the appliance.
11. Do not store or use this appliance outdoors. Do not use this product near water--for example, near a kitchen sink, in a wet basement or near a swimming pool, and the like.
12. Do not immerse cord or plug in water.
13. Keep cord away from heated surfaces.
14. Do not let cord hang over edge of table or counter.
15. See door surface cleaning instructions on page 22.
16. To reduce the risk of fire in the oven cavity:
  - a. Do not overcook food. Carefully attend appliance if paper, plastic or other combustible materials are placed inside the oven to facilitate cooking.
  - b. Remove wire twist-ties from paper or plastic bags before placing bag in oven.
  - c. **If materials inside the oven should ignite, keep oven door closed, turn oven off and disconnect the power cord or shut off power at the fuse or circuit breaker panel.**
  - d. Do not use the cavity for storage purposes. Do not leave paper products, cooking utensils or food in the cavity when not in use.
17. Clean ventilation openings and grease filters frequently – Grease should not be allowed to accumulate on ventilation openings, hood (louver) or grease filters.
18. Use care when cleaning the louver and the grease filters. Corrosive cleaning agents, such as lye-based oven cleaners, may damage the louver and the grease filters.
19. When foods flame under the grease filters, turn the fan off by pushing the FAN button, if possible, or by turning power off at the circuit breaker box. The fan cannot be turned off manually if it had started as a result of heat rising from range units or burners. The fan, if operating, may spread the flame.
20. This appliance is suitable for use above both gas and electric cooking equipment 36" wide or less.
21. **The deflector, item 15 on page 9, is provided for protection against flaming foods from range below and should remain in place at all times. See installation instructions for proper mounting procedures.**

**SAVE THESE INSTRUCTIONS**

# UNPACKING INSTRUCTIONS

## Unpacking and Examining Your Oven

Carefully remove oven from carton. **SAVE THE CARTON AS IT MAY MAKE INSTALLATION EASIER.**

Remove:

1. all packing materials from inside the oven cavity. Check to see that there are Installation Instructions, Wall Template and Top Template. Read enclosures and **SAVE** the Operation Manual.
2. the feature sticker from the outside of the door, if there is one.

Check the oven for any damage, such as misaligned or bent door, damaged door seals and sealing surfaces, broken or loose door hinges and latches and dents inside the cavity or on the door. If there is any damage, do not operate the oven and contact your dealer or SHARP AUTHORIZED SERVICER.

See Installation Instructions for more details.

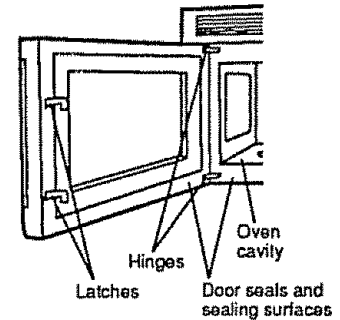

# OPTIONAL ACCESSORIES

Two optional accessories are available for this oven:

1. Charcoal Filter Kit (RK-220). This is required when hood exhaust is recirculated. See Charcoal Filter Kit on page 23. If your dealer does not stock this item, it can be ordered by calling 1-800-BE-SHARP.
2. Filler Panel Kit. For use when the oven is installed in a 36-inch or 42-inch wide opening. The metal filler panels come in pairs, each 3-inches wide. For information contact:  
Modern-Aire Manufacturing Corporation  
7319 Lankershim Blvd.  
North Hollywood, CA 91605  
Phone: (818) 765-9870 or (213) 875-1350 Fax (818) 765-4916

# GROUNDING INSTRUCTIONS

This appliance must be grounded. This oven is equipped with a cord having a grounding wire with a grounding plug. It must be plugged into a wall receptacle that is properly installed and grounded in accordance with the National Electrical Code and local codes and ordinances. In the event of an electrical short circuit, grounding reduces risk of electric shock by providing an escape wire for the electric current.

**WARNING** – Improper use of the grounding plug can result in a risk of electric shock.

## Electrical Requirements

Check Installation Instructions for proper location for the power supply. The electrical requirements are a 120 volt 60 Hz, AC only, 15 amp. or more protected electrical supply. It is recommended that a separate circuit serving only the oven be provided.

The oven is equipped with a 3-prong grounding plug. It must be plugged into a wall receptacle that is properly installed and grounded. **DO NOT UNDER ANY CIRCUMSTANCES CUT OR REMOVE THE GROUNDING PIN FROM THE PLUG.**

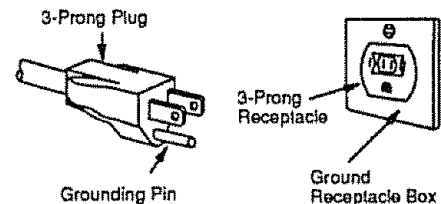

Note:

1. If you have any questions about the grounding or electrical instructions, consult a qualified electrician or service person.
2. Neither Sharp nor the dealer can accept any liability for damage to the oven or personal injury resulting from failure to observe the correct electrical connection procedures.

## Radio or TV Interference

Should there be any interference caused by the microwave oven to your radio or TV, check that the microwave oven is on a different electrical circuit, relocate the radio or TV as far away from the oven as feasible or check position and signal of receiving antenna.

# INFORMATION YOU NEED TO KNOW

## ...About Your Oven

This Operation Manual is valuable: read it carefully and always save it for reference.

A good microwave cookbook is a valuable asset. Check it for microwave cooking principles, techniques, hints and recipes. See the order form on page 27 for ordering the Ultimate Accessory, the SHARP CAROUSEL MICROWAVE COOKBOOK.

**NEVER** use the oven without the turntable and support nor turn the turntable over. This oven can be used both with the turntable turning and with the turntable not turning for large casserole type dishes. See page 12 for complete instructions.

**ALWAYS** have food in the oven when it is on to absorb the microwave energy.

When using the oven at power levels below 100%, you may hear the magnetron cycling on and off.

Condensation is a normal part of microwave cooking. Room humidity and the moisture in food will influence the amount of moisture that condenses in the oven. Generally, covered foods will not cause as much condensation as uncovered ones. Ventilation openings must not be blocked.

The oven is for food preparation only. It should not be used to dry clothes or newspapers.

Your oven is rated 850 watts using the IEC 705-1988 method. In using recipes or package directions, check food at the minimum time and add time accordingly.

## ...About Food

FOOD	DO	DON'T
Eggs, fruits, vegetables & sausages	<ul style="list-style-type: none"> <li>• Puncture egg yolks before cooking to prevent "explosion".</li> <li>• Pierce skins of potatoes, apples, squash, hot dogs and sausages so that steam escapes.</li> </ul>	<ul style="list-style-type: none"> <li>• Cook eggs in shells.</li> <li>• Reheat whole eggs.</li> </ul>
Popcorn	<ul style="list-style-type: none"> <li>• Use specially bagged popcorn for the microwave oven.</li> <li>• Listen while popping corn for the popping to slow to 1 or 2 seconds or use special POPCORN pad.</li> </ul>	<ul style="list-style-type: none"> <li>• Pop popcorn in regular brown bags or glass bowls.</li> <li>• Exceed maximum time on popcorn package.</li> </ul>
Baby food	<ul style="list-style-type: none"> <li>• Transfer baby food to small dish and heat carefully, stirring often. Check temperature before serving.</li> <li>• Put nipples on bottles after heating and shake thoroughly. "Wrist" test before feeding.</li> </ul>	<ul style="list-style-type: none"> <li>• Heat baby food in original jars.</li> <li>• Heat disposable bottles.</li> <li>• Heat bottles with nipples on.</li> </ul>
General	<ul style="list-style-type: none"> <li>• Cut baked goods with filling after heating to release steam and avoid burns.</li> <li>• Stir liquid briskly before and after heating to avoid "eruption".</li> <li>• Use deep bowl, when cooking liquid or cereal, to prevent boilovers.</li> </ul>	<ul style="list-style-type: none"> <li>• Heat or cook in closed glass jars or airtight containers.</li> <li>• Can in the microwave as harmful bacteria may not be destroyed.</li> <li>• Deep fat fry.</li> <li>• Dry wood, gourds, herbs or wet papers.</li> </ul>

# INFORMATION YOU NEED TO KNOW

## ...About Microwave Cooking

- \* Arrange food carefully. Place thickest areas toward outside of dish.
- \* Watch cooking time closely. Cook for the shortest amount of time indicated and add more as needed. Food severely overcooked can smoke or ignite.
- \* Cover foods while cooking. Check recipe or cookbook for suggestions: paper towels, wax paper, microwave plastic wrap or a lid. Covers prevent spattering and help foods to cook evenly.
- \* Shield with small flat pieces of aluminum foil any thin areas of meat or poultry to prevent overcooking before dense, thick areas are cooked thoroughly.
- \* Stir foods from outside to center of dish once or twice during cooking, if possible.
- \* Turn foods over once during microwaving to speed cooking of such foods as chicken and hamburgers. Large items like roasts must be turned over at least once.
- \* Rearrange foods like meatballs halfway through cooking both from top to bottom and from the center of the dish to the outside.
- \* Add standing time. Remove food from oven and stir, if possible. Cover for standing time which allows the food to finish cooking without overcooking.
- \* Check for doneness. Look for signs indicating that cooking temperatures have been reached. Doneness signs include:
  - \* Food steams throughout, not just at edge.
  - \* Center bottom of dish is very hot to the touch.
  - \* Poultry thigh joints move easily.
  - \* Meat and poultry show no pinkness.
  - \* Fish is opaque and flakes easily with a fork.

## ...About Safety

- \* Check foods to see that they are cooked to the United States Department of Agriculture's recommended temperatures.

TEMP	FOOD
160°F	...for fresh pork, boneless white meat of poultry, ground meat, fish, seafood, egg dishes and frozen prepared food.
165°F	...for leftover, ready-to-reheat refrigerated and deli and carry-out "fresh" food.
170°F	...white meat of poultry.
180°F	...dark meat of poultry.

To test for doneness, insert a meat thermometer in a thick or dense area away from fat or bone. Never leave the thermometer in the food during cooking, unless it is approved for microwave oven use.

- \* ALWAYS use potholders to prevent burns when handling utensils that are in contact with hot food. Enough heat from the food can transfer through utensils to cause skin burns.
- \* Avoid steam burns by directing steam away from the face and hands. Slowly lift the farthest edge of a dish's covering and carefully open popcorn and oven cooking bags away from the face.
- \* Stay near the oven while it's in use and check cooking progress frequently so that there is no chance of overcooking food.
- \* NEVER use the cavity for storing cookbooks or other items.
- \* Select, store and handle food carefully to preserve its high quality and minimize the spread of foodborne bacteria.
- \* Keep wave guide cover clean. Food residue can cause arcing and/or fires.



# INFORMATION YOU NEED TO KNOW

## ...About Utensils and Coverings

It is not necessary to buy all new cookware. Many pieces already in your kitchen can be used successfully in your new microwave.

Use these utensils for safe microwave cooking and reheating:

- \* glass ceramic (Pyroceram<sup>®</sup>), such as Corningware<sup>®</sup>.
- \* heat-resistant glass (Pyrex<sup>®</sup>)
- \* microwave-safe plastics
- \* paper plates
- \* microwave-safe pottery, stoneware and porcelain
- \* browning dish (Do not exceed recommended preheating time. Follow manufacturer's directions.)

These items can be used for short time reheating of foods that have little fat or sugar in them:

- \* wood, straw, wicker

### DO NOT USE

- \* metal pans and bakeware
- \* dishes with metallic trim
- \* non-heat-resistant glass
- \* non-microwave-safe plastics (margarine tubs)
- \* recycled paper products
- \* brown paper bags
- \* food storage bags
- \* metal twist-ties

Should you have questions about utensils or covering, check a good microwave cookbook or follow recipe suggestions.

### ACCESSORIES

There are many microwave accessories available for purchase. Evaluate carefully before you purchase so that they meet your needs. A microwave-safe thermometer will assist you in determining correct doneness and assure you that foods have been cooked to safe temperatures. Sharp is not responsible for any damage to the oven when accessories are used.

Should you wish to check if a dish is safe for microwaving, place the empty dish in the oven and microwave on HIGH for 30 seconds. A dish which becomes very hot should not be used.

The following coverings are ideal:

- \* Paper towels are good for covering foods for reheating and absorbing fat while cooking bacon.
- \* Wax paper can be used for cooking and reheating.
- \* Plastic wrap that is specially marked for microwave use can be used for cooking and reheating. DO NOT allow plastic wrap to touch food. Vent so steam can escape.
- \* Lids that are microwave-safe are a good choice because heat is kept near the food to hasten cooking.
- \* Oven cooking bags are good for large meats or foods that need tenderizing. DO NOT use metal twist-ties. Remember to slit bag so steam can escape.

How to use aluminum foil in your microwave oven:

- \* Small flat pieces of aluminum foil placed smoothly on the food can be used to shield areas that are either defrosting or cooking too quickly.
- \* Foil should not come closer than one inch to any surface of the oven.

## ...About Children and the Microwave

\* Children below the age of 7 should use the microwave with a supervising person very near to them. Between the ages of 7 and 12, the supervising person should be in the same room.

\* The child must be able to reach the oven comfortably; if not, he/she should stand on a sturdy stool.

\* At no time should anyone be allowed to swing on or pull down on the oven door.

\* Children should be taught all safety precautions: use potholders, remove coverings carefully, pay special attention to packages that crisp food because they may be extra hot.

\* Don't assume that because a child has mastered one cooking skill he/she can cook everything.

\* Children need to learn that the microwave oven is not a toy.

# PART NAMES

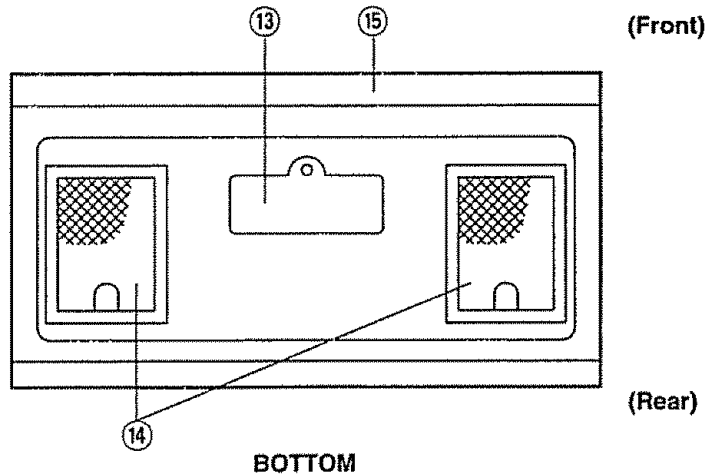
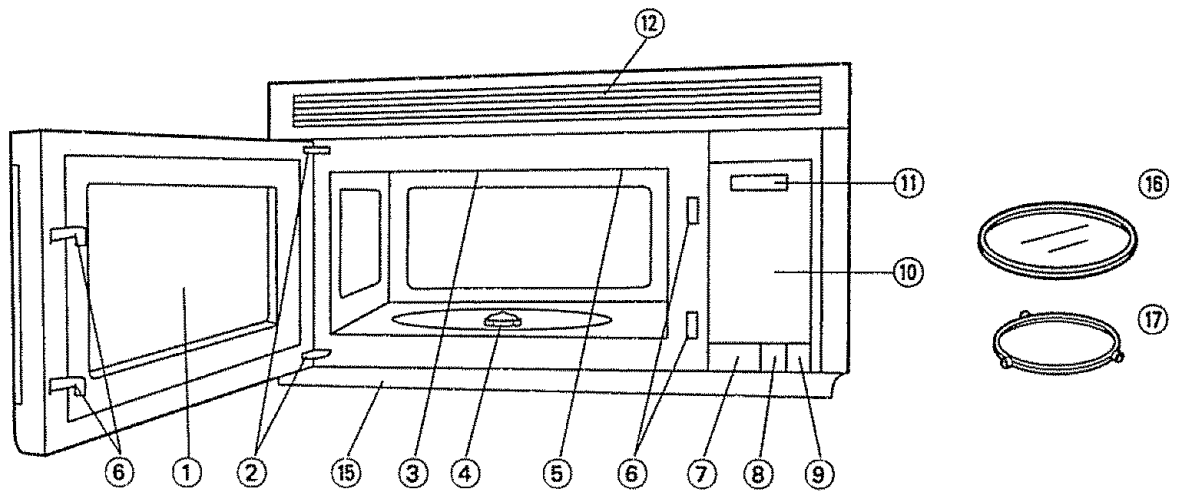

1. Oven door with see-through window.
2. Door hinges.
3. Wave guide cover.
4. Turntable motor shaft.
5. Oven light.  
It will light when oven is operating or door is open.
6. Safety door latches.  
The oven will not operate unless the door is securely closed.
7. One touch DOOR OPEN button.  
Push to open door.
8. FAN HI / LO button.  
Push for High/Low/Off.
9. LIGHT button.  
Push for On/Off.

10. Auto-Touch control panel.
11. Time display: Digital display, 99 minutes 99 seconds.
12. Ventilation openings.
13. Light cover.
14. Grease filters.
15. Deflector.  
Must be installed according to directions in the Installation Instructions.
16. Removable turntable.  
The turntable will rotate clockwise or counterclockwise. Only remove for cleaning.
17. Removable turntable support.  
Place the turntable support on the floor of the oven cavity and the turntable on the turntable support.

# TOUCH CONTROL PANEL



Control panel display  
 Words will light in the display to indicate features and cooking instructions.

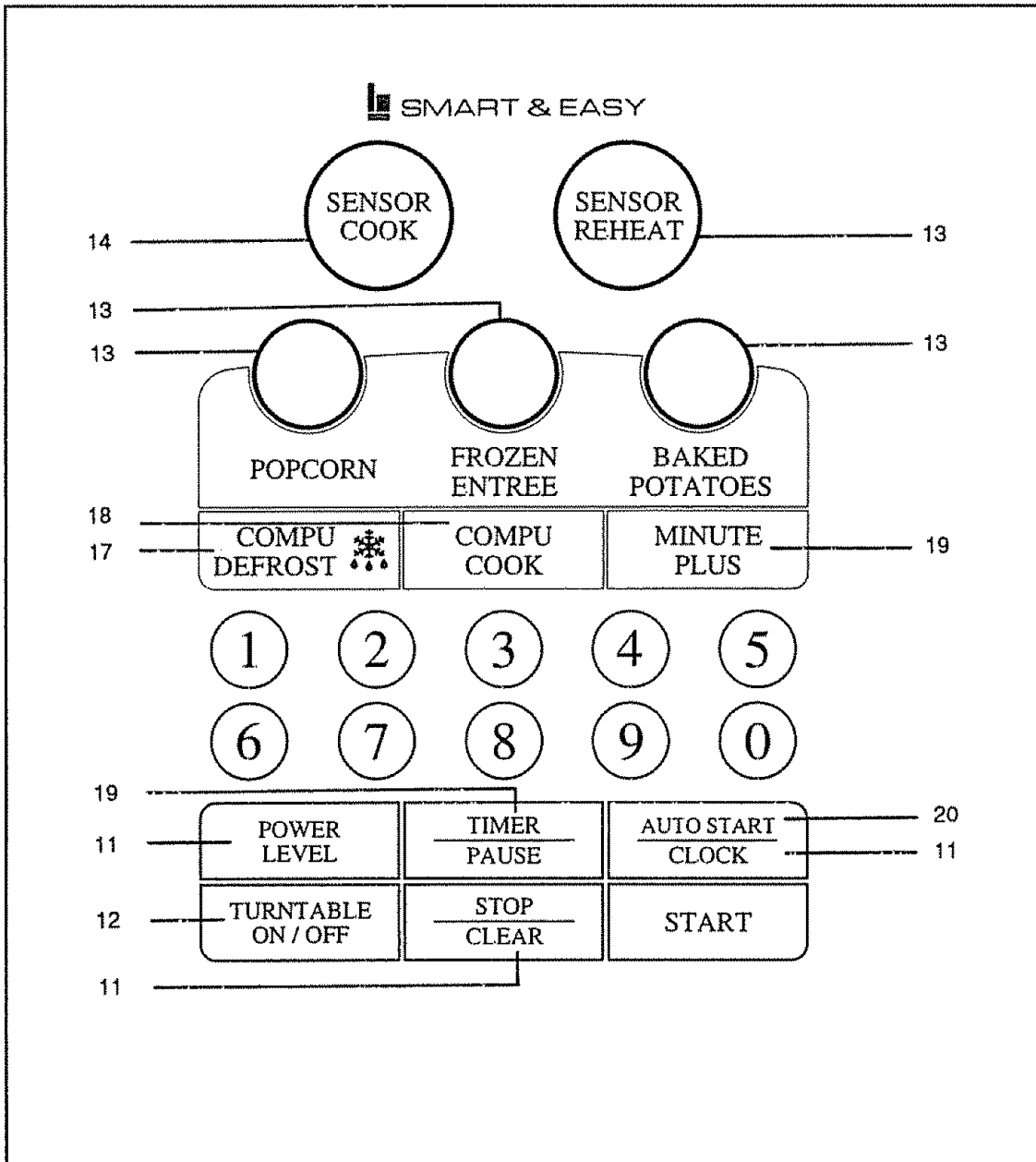

Number indicates page on which there are a feature description and usage information.

## BEFORE OPERATING

- Before the oven can be used, follow these procedures:
  - 1) Plug in the oven. Close the door.  
The oven display will then begin flashing **88:88**. TURNTABLE and ON indicators will go on.
  - 2) Touch the STOP/CLEAR pad.  
**88:88** will appear.
  - 3) Set clock.

## To Set the Clock

- Suppose you want to enter the correct time of day 12:30 (A.M. or P.M.)

Procedure	Display
<p><b>AUTO START CLOCK</b></p> <p>1. Touch AUTO START/CLOCK pad.</p>	<p><b>0</b></p> <p>TURNTABLE ON</p>
<p><b>1 2 3 0</b></p> <p>2. Enter the correct time of day by touching the numbers in sequence.</p>	<p><b>12 30</b></p> <p>TURNTABLE ON</p>
<p><b>AUTO START CLOCK</b></p> <p>3. Touch AUTO START/CLOCK pad again.</p>	<p><b>12:30</b></p> <p>TURNTABLE ON</p>

This is a 12 hour clock. If you attempt to enter an incorrect clock time, **ERROR** will appear in the display. Touch the STOP/CLEAR pad and re-enter the time.

- If the electrical power supply to your microwave oven should be interrupted, the display will intermittently show **88:88** after the power is reinstated. If this occurs during cooking, the program will be erased. The time of day will also be erased. Simply touch STOP/CLEAR pad and reset the clock for the correct time of day.

NOTE: Your oven can be programmed with the door open except for START, COMPU DEFROST, MINUTE PLUS and Instant Sensors.

## Stop/Clear

Touch the STOP/CLEAR pad to:

1. Erase if you make a mistake during programming.
2. Cancel minute timer.
3. Stop the oven temporarily during cooking.
4. Return the time of day to the display.
5. Cancel a program during cooking, touch twice.

## MANUAL OPERATION

## Time Cooking

Your oven can be programmed for 99 minutes 99 seconds (99 99). Always enter the seconds after the minutes, even if they are both zeros.

- Suppose you want to cook for 5 minutes at 100%.

Procedure	Display
<p><b>5 0 0</b></p> <p>1. Enter cooking time.</p>	<p><b>5 00</b></p> <p>TURNTABLE ON</p>
<p><b>START</b></p> <p>2. Touch START pad.</p>	<p><b>5.00</b></p> <p>COOK TURNTABLE ON</p>

There are eleven preset power levels.

Using lower power levels increases the cooking time which is recommended for foods such as cheese, milk and long slow cooking of meats. Consult cookbook or recipes for specific recommendations.

Touch POWER LEVEL Pad Once, then Touch	Approximate Percentage of Power	Common Words for Power Levels
POWER LEVEL	100%	High
9	90%	
8	80%	
7	70%	Medium High
6	60%	
5	50%	Medium
4	40%	
3	30%	Med. Low/Defrost
2	20%	
1	10%	Low
0	0%	

- Suppose you want to defrost for 5 minutes at 30%.

Procedure	Display
<p><b>5 0 0</b></p> <p>1. Enter cooking time.</p>	<p><b>5 00</b></p> <p>TURNTABLE ON</p>
<p><b>POWER LEVEL 3</b></p> <p>2. Enter power level.</p>	<p><b>P- 30</b></p> <p>TURNTABLE ON</p>
<p><b>START</b></p> <p>3. Touch START pad.</p>	<p><b>5.00</b></p> <p>COOK TURNTABLE ON</p>

## MANUAL OPERATION

### Turntable On / Off

For most cooking, the turntable should be on; however the turntable can be turned off so that it does not rotate when extra large dishes, such as the popular 13 x 9 x 2 glass utility casserole, are used. The casserole should be placed on the turntable so that it is level.

\* Suppose you want to cook lasagna in a 13 x 9 x 2 casserole for 45 minutes on 40% power.

Procedure	Display
<b>1</b> <span style="border: 1px solid black; padding: 2px;">TURNTABLE ON / OFF</span> Touch TURNTABLE ON/OFF pad and note TURNTABLE OFF in the display.	TURNTABLE OFF
<b>2</b> <span style="border: 1px solid black; border-radius: 50%; padding: 2px;">4</span> <span style="border: 1px solid black; border-radius: 50%; padding: 2px;">5</span> <span style="border: 1px solid black; border-radius: 50%; padding: 2px;">0</span> <span style="border: 1px solid black; border-radius: 50%; padding: 2px;">0</span> Enter cooking time.	45 00 TURNTABLE OFF
<b>3</b> <span style="border: 1px solid black; padding: 2px;">POWER LEVEL</span> <span style="border: 1px solid black; border-radius: 50%; padding: 2px;">4</span> Enter Power level.	P- 40 TURNTABLE OFF
<b>4</b> <span style="border: 1px solid black; padding: 2px;">START</span> Touch START pad.	45.00 COOK TURNTABLE OFF

#### NOTE:

The door can be opened for checking food and the turntable will stay in the off position. After checking, close door and touch START.

The turntable will stay off for one minute after door is opened when time-of-day appears in the display. It is possible to reprogram the oven during that minute without touching the TURNTABLE ON/OFF pad. The display always indicates whether the turntable is off or on.

THE TURNTABLE SHOULD ALWAYS BE ON WHEN USING THE SPECIAL FEATURES. Only manual operation is available when the turntable is off.

When cooking large quantities of food which cannot be stirred, it is best to use a lower power level such as 40 or 50%. You may speed cooking of large amounts by programming 5 to 10 minutes on 100% power (HIGH) followed by the desired time on lower power. See page 19 for how to program multiple sequences. You may wish to reverse a large casserole once during cooking; simply open door, reposition casserole, close door and touch START.

## SPECIAL FEATURES

### Sensor Cooking

Sharp's Sensor is a semi-conductor device that detects the vapor (moisture and humidity) emitted from the food as it heats. The Sensor adjusts the cooking times and power level for various foods and quantities. It takes the guesswork out of microwave cooking.

#### Using Sensor Settings:

- Room temperature should not exceed 95° F.
- Be sure the exterior of the cooking container and the interior of the oven are dry. Wipe off any moisture with a dry cloth or paper towel.
- Sensor cooking can only be entered within 1 minute after cooking, opening and closing the door or touching the STOP/CLEAR pad.
- During the first part of sensor cooking, SE-, SENSOR, ERRR, RE-, HEAT, ERR, TURN will appear on display. Do not open the oven door or touch STOP/CLEAR during this part of the cooking cycle. The measurement of vapor will be interrupted. If this occurs, ERRR will appear and sensor cooking will be interrupted. To continue cooking, touch the STOP/CLEAR pad and select cooking time and power. When sensor detects the vapor emitted from the food, remainder of cooking time will appear. Door may be opened when remaining cooking time appears on display. At this time, you may stir or season food, as desired.
- Check food for doneness after cooking with sensor settings. If additional time is needed, continue to cook with variable power and time.
- If the sensor does not detect vapor, ERRR will appear and the oven will shut off.
- At the end of any cycle, open oven door or touch STOP/CLEAR pad. The time of day will reappear on the display.
- Any Sensor setting can be programmed with More or Less Time Adjustment. See page 20.

#### Selecting Foods:

- The sensor works with foods at normal storage temperature. For example, foods for reheating would be at refrigerator temperature and potatoes for baking would be room temperature.
- More or less food than the quantity listed in the charts should be cooked by time and variable power.

#### Covering Foods:

Some foods work best when covered. Use the cover recommended in the chart for these foods.

- Casserole lid.
- Plastic wrap: Use plastic wrap recommended for microwave cooking. Cover dish loosely; allow approximately 1/2 inch to remain uncovered to allow steam to escape. Plastic wrap should not touch food.
- Paper towel: Use paper towels to absorb excess fat and moisture when cooking bacon and potatoes. Line the turntable when baking potatoes.
- Wax paper: Cover dish completely; fold excess wrap under dish to secure. If dish is wider than paper, overlap two pieces at least one inch to cover.

# SPECIAL FEATURES/ INSTANT SENSORS

## Frozen Entree

You can heat frozen entrees by touching just one pad. You don't need to calculate cooking time or power level.

\* Suppose you want to heat a frozen entree.

Procedure	Display
<b>1</b>  Touch FROZEN ENTREE pad.	<b>SENSOR</b> and <b>FROZN</b> will be displayed repeatedly.  After cooking, <b>COVER</b> and <b>STANB</b> will be displayed repeatedly.

## Sensor Reheat

You can reheat foods by touching just one pad. You don't need to calculate cooking time or power level.

\* Suppose you want to reheat canned chili.

Procedure	Display
<b>1</b>  Touch SENSOR REHEAT pad.	<b>RE-</b> and <b>HEAT</b> will be displayed repeatedly.  After cooking, <b>COVER</b> and <b>STANB</b> will be displayed repeatedly.

## Baked Potatoes

\* Suppose you want to cook 2 baked potatoes.

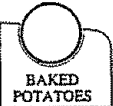
Procedure	Display
<b>1</b>  Touch BAKED POTATOES pad.	<b>SENSOR</b> will be displayed repeatedly.  After cooking, <b>COVER</b> and <b>STANB</b> will be displayed repeatedly.

## Popcorn

\* Suppose you want to pop one package of microwave popcorn.

Procedure	Display
<b>1</b>  Touch POPCORN pad.	<b>POP</b> and <b>CORN</b> will be displayed repeatedly.  After cooking, <b>End</b> will be displayed repeatedly.

NOTE: Be careful when removing any covering to allow steam to escape away from you.

## Instant Sensor Chart



Frozen Entree	6-16 oz.	Use this pad for frozen convenience foods. It will give satisfactory results for most brands. You may wish to try several and choose your favorite. Remove package from outer wrapping and follow package directions for covering. After cooking, let stand, covered, for 1 to 3 minutes.
Sensor Reheat Leftovers such as rice, potatoes, vegetables, casserole	4-32 oz.	Place in dish or casserole slightly larger than amount to be reheated. Flatten, if possible. Cover with lid, plastic wrap or wax paper. Use covers such as plastic wrap or lids with larger quantities of more dense foods such as stews. After reheating, stir well, if possible. Foods should be very hot. If not, continue to heat with variable power and time. After stirring, re-cover and allow to stand 2 to 3 minutes.
Soup	1-4 cups	
Canned entrees and vegetables	4-16 oz.	
Hot dogs	1-2	Place hot dog in bun and wrap in paper towel or paper napkin.
Dinner plate	1 plate (3-6 oz. plus vegetables and/ or potato/ rice)	Place meaty portions and bulky vegetables to outside of plate. Cut large items like baked potatoes into smaller pieces. Flatten foods such as mashed potato and other dense foods. Cover with wax paper or plastic wrap. After cooking, check that food is very hot throughout and that the bottom center of the plate is very hot. If not, continue heating using time and power level. Stand, covered, 2 to 3 minutes.
Popcorn	Only 1 package at a time, any size bag	Use only popcorn packaged for microwave oven use. Try several brands to decide which you like best. Fresh popcorn works best so purchase only the amount used in a week or two. Do not try to pop unpopped kernels. More or Less Time Adjustment can be used to provide adjustment needed for older popcorn or individual tastes.
Baked Potatoes		
White potatoes	1-6 medium	Prick with a fork. Place on paper-towel-lined turntable. After cooking, remove from oven, wrap in aluminum foil and let stand 5 to 10 minutes.
Sweet potatoes	1-6 medium	



# SPECIAL FEATURES

## Sensor Cook

Sensor Cook will automatically compute the microwave power and cooking time for foods shown in the chart below. You don't need to enter the weight of the food.

\* Suppose you want to use Sensor Cook to cook bacon.

Procedure	Display
<b>1</b>  Touch SENSOR COOK pad.	

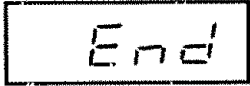
<b>2</b> <b>4</b> Select SENSOR COOK setting. Touch 4 to cook bacon.	
<b>3</b>  Touch START pad.	
<b>4</b> After cooking.	

## Sensor Cook Chart

Food	Amount	Procedure
1. Fresh vegetables, soft Broccoli Brussels sprouts Cabbage Cauliflower (flowerets) Cauliflower (whole) Spinach Zucchini Baked apples	0.5-2.0 lbs. 0.5-2.0 lbs. 0.5-2.0 lbs. 0.5-2.0 lbs. 1 medium 0.25-1.0 lb. 0.25-2.0 lbs. 2-4 medium	Wash and place in casserole. Add no water if vegetables have just been washed. Cover with lid for tender vegetables. Use plastic wrap for tender-crisp vegetables. Stir before standing if possible. After cooking, let stand, covered, 2-5 minutes.  Peel around top and remove core. Place sugar or cinnamon candies in core. Place apples in a glass pie plate. Cover with plastic wrap.
2. Fresh vegetables, hard Carrots, sliced Corn on cob Green beans Winter squash, diced Winter squash, halves	0.25-1.5 lbs. 2-4 pcs. 0.25-1.0 lb. 0.25-1.0 lb. 1-2	Place in casserole. Add 1-4 tbsp. water. Cover with lid for tender vegetables. Use plastic wrap cover for tender-crisp vegetables. Stir before standing, if possible. After cooking, let stand, covered, 2-5 minutes.
3. Frozen vegetables	1-6 cups	Cover with lid or plastic wrap. After cooking, stir and let stand 3 minutes, covered.
4. Bacon	2-6 slices	Place bacon on paper plate, lined with paper towel. Bacon should not extend over the rim of plate. Cover with paper towel.
5. Fish, seafood Fillet, steak Shrimp Scallops fresh or frozen, thawed Clams, fresh	0.25-2.0 lbs. 0.25-2.0 lbs. 0.25-2.0 lbs. 0.25-2.0 lbs.	Arrange in ring around shallow glass dish (Roll fillet with edges underneath). Cover with plastic wrap. After cooking, let stand, covered, 3 minutes.  Place in plastic bag. Secure end. Slit bag with a knife. Stand, covered, approximately 3 minutes.
6. Ground meat	0.3-2.0 lbs.	Use this setting to cook ground beef or turkey as patties or in a casserole to be added to other ingredients. Place patties on a microwave-safe rack and cover with wax paper. Place ground meat in a casserole and cover with wax paper or plastic wrap. When oven stops and <b>TURN OVER</b> is displayed, turn patties over or stir meat in casserole to break up large pieces. With small quantities, there may not be a <b>TURN OVER</b> . Re-cover and touch START. After cooking, let stand, covered for 2 to 3 minutes.

# Sensor Cook Recipes

## Cranberry Fluff

- |   |   |
|---|---|
| 2 cups fresh cranberries                    | 1/2 pint whipping cream, whipped or           |
| 1 cup water                                 | 1 carton (8 ounces) non-dairy whipped topping |
| 3/4 cup sugar                               |   |
| 1 carton (3 ounces) orange flavored gelatin | Makes 6 to 8 servings                         |

1. Combine cranberries, water and sugar in a 2-quart casserole. Cover with wax paper. Microwave using SENSOR REHEAT Less. Drain cranberries and reserve liquid.
2. Add enough hot water to reserved liquid to make 2 cups. Stir the gelatin into hot liquid until it dissolves. Cover with wax paper. Microwave using SENSOR REHEAT Less.
3. Add berries and cool. Refrigerate until thickened. Fold whipped cream into cooled cranberry mixture. Spoon into serving dishes and garnish with extra whipped cream. Refrigerate until ready to serve.

## Curry Vegetable Chowder

- |  |                                     |
|--|-------------------------------------|
| 6 slices bacon                                 | 3/4 teaspoon salt                   |
| 1 can (10 3/4 ounces) chicken broth            | 1/2 teaspoon curry powder           |
| 3 medium potatoes, finely diced (about 2 cups) | 1/8 teaspoon pepper                 |
| 2 carrots, shredded (about 1 cup)              | 1 can (12 ounces) evaporated milk   |
| 1 small onion, chopped (about 1/2 cup)         | 2 tablespoons chopped fresh parsley |
- Makes 4 servings

1. Layer 2 paper towels on a microwave-safe plate. Arrange bacon on the towels. Cover with another paper towel. Microwave using SENSOR COOK 4 for bacon. Crumble and reserve bacon.
2. Combine chicken broth, vegetables and seasonings in 4-quart casserole. Cover with vented plastic wrap. Microwave using Instant Sensor BAKED POTATOES. Vegetables should be tender.
3. Stir in evaporated milk. Re-cover with vented plastic wrap. Microwave using SENSOR REHEAT. Stir in parsley. Let stand, covered, 5 minutes.
4. Top each serving with crumbled bacon.

## Glazed Apple Slices

- |                                   |  |
|-----------------------------------|--|
| 1/4 cup packed brown sugar        | 3/4 cup orange juice   |
| 3 tablespoons margarine or butter | 1 tablespoon cornstarch  |
| 2 tablespoons apricot preserves   | 4 baking apples (about 1 1/2 pounds), peeled and sliced into 8 pieces each |
| 1/2 teaspoon ground nutmeg        | 3 tablespoons chopped green pistachios                                     |
| 1/4 teaspoon salt                 | Makes 6 to 8 servings  |
| 1/2 cup sugar                     |  |

1. Combine brown sugar, margarine and apricot preserves in a small bowl. Microwave at HIGH (100%) until margarine melts and preserves soften, 45 seconds to 1 minute. Stir in nutmeg, salt, sugar, orange juice and cornstarch. Microwave at HIGH (100%) until thickened, 4 to 6 minutes, stirring several times.
2. Arrange apple slices in a large microwave serving dish. Spread hot sauce over apples. Cover well with vented plastic wrap. Microwave using SENSOR COOK 1 for fresh vegetables, soft. Allow to cool 5 minutes before serving.
3. Sprinkle with pistachios. Serve alone or over vanilla ice cream or sponge cake.

## Crab Stuffed Zucchini

- |  |   |
|--|---|
| 2 pounds medium zucchini, cut into 3/4-inch thick slices | 3 tablespoons mayonnaise                                    |
| garlic salt  | 3 tablespoons finely chopped pecans                         |
| 1/2 pound lump crabmeat, shredded                        | 1 can (8 ounces) crushed pineapple packed in juice, drained |
|  | 1/8 teaspoon curry powder                                   |

Makes about 20 zucchini slices

1. Scoop out zucchini slices with melon baller, leaving a 1/4-inch shell. Sprinkle inside with garlic salt. Set aside.
2. Mix crabmeat, mayonnaise, pecans, crushed pineapple and curry powder in medium bowl. Fill each zucchini slice with 1 tablespoon of mixture.
3. Place on paper towel on a glass pie plate. Cover with wax paper. Microwave using SENSOR COOK 1 for fresh vegetables, soft.
4. Stand, covered, 5 minutes.



## Mexican Seasoned Potatoes

4	medium baking potatoes (8 ounces each)	1/2	teaspoon oregano leaves
1/4	cup olive oil	1/4	teaspoon ground cumin
1	tablespoon instant minced onion	1/2	teaspoon salt
1/2	teaspoon chili powder		

Makes 6 to 8 servings

1. Cut each potato lengthwise into 4 equal wedges. Place potato wedges into 10-inch square casserole. Toss potatoes with oil to coat well.
2. In small bowl, combine remaining ingredients. Sprinkle over potatoes.
3. Cover potatoes with wax paper. Microwave using Instant Sensor BAKED POTATOES. Rearrange potatoes when time appears on display. Let stand, covered, 5 minutes.

## Microwaved Fresh Pumpkin

1 Pie Pumpkin or Sugar Pumpkin

1. Wash and cut pumpkin into quarters. Remove seeds and strings. Place in a glass pie plate. Cover well with vented plastic wrap.
2. Microwave using SENSOR COOK 2 for fresh vegetables, hard. Allow to stand, covered, 5 minutes.
3. Scrape the pulp from the shell. Strain off excess liquid from cooked pumpkin. Place pumpkin into food processor or blender and process until smooth. Use in your favorite recipes.

## Spiced Carrots

3	cups sliced carrots, 1/4 inch thick	2	teaspoons vinegar
1/2	cup chopped green pepper, 1-inch cubes	1	teaspoon soy sauce
1/4	cup finely chopped onion	1/2	teaspoon salt
3	tablespoons water	1/2	teaspoon prepared mustard
1	can (7 3/4 ounces) semi-condensed tomato soup	1/8	teaspoon pepper
1/2	cup sugar		

Makes 6 to 8 servings

1. In a 1 1/2-quart casserole, combine carrots, green pepper, onion and water. Cover with lid. Microwave using SENSOR COOK 2 for fresh vegetables, hard. Carrots should be tender-crisp. Drain.
2. Stir in remaining ingredients. Cover and microwave using SENSOR REHEAT.

## Ham and Cheese Stuffed Mushrooms

1	pound fresh mushrooms (about 18 1 1/2-inch mushrooms)	2-4	drops red pepper sauce
2	tablespoons cream cheese, softened	1	teaspoon Worcestershire sauce
1	cup shredded baked ham (about 1/4 pound)	3	green onions, chopped
1	cup shredded sharp Cheddar cheese	1/4	cup dry bread crumbs
2	tablespoons Dijon mustard		grated Parmesan cheese

Makes about 18 appetizers

1. Wash mushrooms. Remove stems and scoop out mushroom leaving 1/2-inch shell. Place mushroom caps on paper toweling on glass utility dish.
2. Combine cream cheese, ham, Cheddar cheese, Dijon mustard, red pepper sauce, Worcestershire sauce, green onion and bread crumbs in a small bowl. Fill each mushroom cap with 1 tablespoon of mixture. Cover with vented plastic wrap. Microwave using SENSOR REHEAT. Let stand, covered, 5 minutes.
3. Sprinkle with Parmesan cheese and serve.

# SPECIAL FEATURES

## CompuDefrost

CompuDefrost automatically defrosts ground meat, chicken pieces, steaks, fish, chops, whole chicken and roasts.

Round the weight to the nearest half pound. (Ex. if the steak's actual weight is 2.2 lbs., round to 2.0 lbs. If the steak's weight is 2.4 lbs., round to 2.5 lbs.)

To enter weight, touch the COMPU DEFROST pad for a .5 lb. increase per touch. (Ex. touch four times for 2.0 lbs.)

\* Suppose you want to defrost a 2.2 lb. steak .

Procedure	Display
<p><b>1</b> Round the weight to 2.0 lbs. Quickly touch COMPU DEFROST 4 times for 2.0 lbs. because the oven starts automatically.</p> <p>The oven will stop and directions will be displayed. Follow the indicated message.</p>	<p>COMPU DEFROST x 4</p> <p>COMPU DEFROST 2.0</p> <p>TURNTABLE ON LBS.</p>

<p><b>2</b> After the 1st stage, open the door. Turn steak over and shield any warm portions. Close the door.</p> <p>START</p> <p>Touch START pad.</p>	<p>CHEK</p> <p>TURN OVER</p> <p>PRESS START</p>
<p><b>3</b> After the 2nd stage, open the door. Shield any warm portions. Close the door.</p> <p>START</p> <p>Touch START pad.</p>	<p>CHEK</p> <p>PRESS START</p>
<p><b>4</b> After cooking.</p>	<p>COVER STAND</p>

### NOTE:

1. CompuDefrost can be programmed with More or Less Time Adjustment. See page 20.
2. You may choose to enter the weight in tenths of pounds. This procedure may be easier with larger weights such as 4 pounds because it requires fewer touches. To program, touch COMPU DEFROST and enter weight by touching the number pads. Example: touch COMPU DEFROST then 4 and 0 for a weight of four pounds.
3. To defrost other foods or foods above or below the weights allowed on the chart below, use time and 30% power. See Manual Defrost on page 18.

## CompuDefrost Chart

Food	Amount	Procedure
Roast	2.5-6.0 lbs.	Start with fat side down. After each stage of defrost cycle, turn over and shield the warm portions with aluminum foil. Stand, covered 30-60 minutes.
Steaks, Chops, Fish	0.5-4.0 lbs.	After each stage of defrost cycle, rearrange and if there are warm or thawed portions, shield with small flat pieces of aluminum foil. Remove any that are nearly defrosted. Stand, covered 10-20 minutes.
Ground meat	0.5-3.0 lbs.	Remove any thawed pieces after each stage. Stand, 5-10 minutes.
Chicken, whole	2.5-6.0 lbs.	Remove giblets before freezing poultry. Start with breast side down. After the 1st stage, turn over and shield the warm portions with aluminum foil. After the 2nd stage, if there are warm portions, shield with aluminum foil. Stand, covered 30-60 minutes.
Chicken pieces	0.5-3.0 lbs.	After each stage of defrost cycle, if there are warm or thawed portions, rearrange or remove. Stand, 10-20 minutes.

**NOTE:** Check foods when oven signals. After final stage, small sections may still be icy. Let stand to continue thawing. Do not defrost until all ice crystals are thawed. Shielding roasts and steaks prevents cooking from occurring before the center of the food is defrosted. Use small smooth strips of aluminum foil to cover edges and thinner sections of the food.

# SPECIAL FEATURES

## Manual Defrost

If the food that you wish to defrost is not listed on the COMPU DEFROST CHART or is above or below the limits in the "Amount" column on the chart, you need to defrost manually.

You can defrost any frozen food, either raw or previously cooked, by using Power Level 3. Follow the exact 3-step procedure found under Time Cooking on page 11. Estimate defrosting time and press 3 for 30% when you select the power level.

For either raw or previously cooked frozen food, the rule of thumb is approximately 5 minutes per pound. For example, defrost 5 minutes for 2-3 cups of casserole or 1 pound of frozen spaghetti sauce.





Always stop the oven periodically to remove or separate the portions that are defrosted. If food is not defrosted at the end of the estimated defrosting time, program the oven in 1 minute increments on Power Level 3 until totally defrosted.



When using plastic containers from the freezer, defrost only long enough to remove from the plastic in order to place food in a microwave-safe dish.

## CompuCook

CompuCook will automatically compute the microwave power and cooking time for foods shown in the chart.

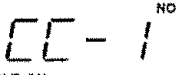

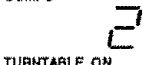

\* Suppose you want to use CompuCook to warm 2 frozen muffins.

Procedure	Display
<b>1</b>  Touch COMPU COOK pad.	COMPU TURNTABLE ON 
<b>2</b>  Select CompuCook setting. Touch  to warm frozen muffins.	COMPU TURNTABLE ON 

<b>3</b>  Enter number.	COMPU TURNTABLE ON 
<b>4</b>  Touch START pad.	
<b>5</b> After cooking.	

NOTE: CompuCook can be programmed with More or Less Time Adjustment. See page 20.

## CompuCook Chart

Food	Amount	Procedure															
1/2 Roll, muffin (Frozen, Fresh)	1-6 pcs.	Use this setting to warm rolls, muffins, biscuits, bagels etc. Large items should be considered as 2 or 3 regular size. Arrange on a plate with a paper towel; cover with another paper towel.															
3 Chicken pieces	0.5-3.5 lbs.	Arrange pieces with meatiest portions toward outside of microwave-safe rack. Cover with vented plastic wrap. At signal, rearrange pieces. Re-cover. After cooking, let stand, covered, 3-5 minutes. Dark meat should be 180°F., and white meat should be 170°F.															
4 Roast pork	2.0-3.5 lbs.	Boneless pork loin is recommended because it cooks evenly. Place on a microwave-safe rack. Cover with vented plastic wrap. At signal, turn over. Shield with small, flat pieces of aluminum foil any areas that are cooking too rapidly. Re-cover. After cooking, remove from oven, cover with foil and allow to stand 10 minutes. Internal temperature should be 170°F.															
5 Turkey breast	3.0-6.0 lbs.	Place skin side down on a microwave-safe rack. Cover with vented plastic wrap. At signal, turn over. Shield with small, flat pieces of aluminum foil any areas that are cooking too rapidly. Re-cover. After cooking, remove from oven. Cover with foil and allow to stand 10 to 15 minutes. Internal temperatures should be 170°F.															
6 Rice	0.5-2.0 cups	Place rice into a deep casserole and add double quantity of water. Cover with lid or plastic wrap. To enter amount, at Procedure 3 above, touch  for 1/2 cup,  for 1 cup,  for 1 1/2 cups and  for 2 cups of rice. After cooking, stir, cover and let stand 3 to 5 minutes or until all liquid has been absorbed.															
		<table border="0"> <thead> <tr> <th>Rice</th> <th>Water</th> <th>Size of casserole</th> </tr> </thead> <tbody> <tr> <td>1/2 cup</td> <td>1 cup</td> <td>1.5 quart</td> </tr> <tr> <td>1 cup</td> <td>2 cups</td> <td>2 quart</td> </tr> <tr> <td>1 1/2 cups</td> <td>3 cups</td> <td>2.5 or 3 quart</td> </tr> <tr> <td>2 cups</td> <td>4 cups</td> <td>3 quart or larger</td> </tr> </tbody> </table>	Rice	Water	Size of casserole	1/2 cup	1 cup	1.5 quart	1 cup	2 cups	2 quart	1 1/2 cups	3 cups	2.5 or 3 quart	2 cups	4 cups	3 quart or larger
Rice	Water	Size of casserole															
1/2 cup	1 cup	1.5 quart															
1 cup	2 cups	2 quart															
1 1/2 cups	3 cups	2.5 or 3 quart															
2 cups	4 cups	3 quart or larger															

# OTHER CONVENIENT FEATURES

## Minute Plus

Minute Plus allows you to cook for a minute at 100% by simply touching the MINUTE PLUS pad. You can also extend cooking time in multiples of 1 minute by repeatedly touching the MINUTE PLUS pad during manual cooking.

\* Suppose you want to heat a cup of soup for one minute.

Procedure	
<b>1</b>	<div style="display: flex; align-items: center; gap: 10px;"> <div style="border: 1px solid black; padding: 5px; text-align: center;">MINUTE PLUS</div> <div>Touch MINUTE PLUS pad.</div> </div>

NOTE: 1. To use MINUTE PLUS, touch pad within 1 minute after cooking, closing the door, touching the STOP/CLEAR pad or during cooking. Minute Plus cannot be used to start the oven if any program is on display.

2. Minute Plus cannot be used with SPECIAL FEATURES.

## Multiple Sequence Cooking

The oven can be programmed for up to 4 automatic cooking sequences, switching from one power level setting to another automatically.

Sometimes cooking directions tell you to start on one power level and then change to a different power level. Your oven can do this automatically.

\* Suppose you want to cook roast beef for 5 minutes at 100% and then continue to cook for 30 minutes at 50%.

Procedure	
<b>1</b>	<div style="display: flex; align-items: center; gap: 10px;"> <div style="text-align: center;"> <span style="font-size: 24px;">5</span> <span style="font-size: 24px;">0</span> <span style="font-size: 24px;">0</span> </div> <div>Enter first cooking time. Then touch POWER LEVEL pad twice for 100% power.</div> </div> <div style="margin-left: 20px;"> <div style="border: 1px solid black; padding: 5px; text-align: center;">POWER LEVEL</div> <div style="font-size: 24px;">x 2</div> </div>
<b>2</b>	<div style="display: flex; align-items: center; gap: 10px;"> <div style="text-align: center;"> <span style="font-size: 24px;">3</span> <span style="font-size: 24px;">0</span> <span style="font-size: 24px;">0</span> <span style="font-size: 24px;">0</span> </div> <div>Enter second cooking time. Touch POWER LEVEL pad and touch number pad 5 for 50% power.</div> </div> <div style="margin-left: 20px;"> <div style="border: 1px solid black; padding: 5px; text-align: center;">POWER LEVEL</div> <div style="margin-top: 10px; text-align: center; font-size: 24px;">5</div> </div>
<b>3</b>	<div style="display: flex; align-items: center; gap: 10px;"> <div style="border: 1px solid black; padding: 5px; text-align: center;">START</div> <div>Touch START pad.</div> </div>

NOTE: 1. If POWER LEVEL pad is touched twice, **P-H I** will be displayed.

2. If 100% is selected as the final sequence, it is not necessary to touch the POWER LEVEL pad.

3. If you wish to know power level, simply touch the POWER LEVEL pad. As long as your finger is touching the POWER LEVEL pad, the power level will be displayed.

## Minute Timer

\* Suppose you want to time a 3 minute long distance phone call.

Procedure	
<b>1</b>	<div style="display: flex; align-items: center; gap: 10px;"> <div style="text-align: center;"> <span style="font-size: 24px;">3</span> <span style="font-size: 24px;">0</span> <span style="font-size: 24px;">0</span> </div> <div>Enter time.</div> </div>
<b>2</b>	<div style="display: flex; align-items: center; gap: 10px;"> <div style="border: 1px solid black; padding: 5px; text-align: center;">TIMER PAUSE</div> <div>Touch TIMER/PAUSE pad.</div> </div>

## Pause

Pause allows you to stop the oven between cooking stages to stir, turn food over or add ingredients during the cooking process.

\* Suppose you want to cook for 5 minutes at 100%, stir and continue to cook for 3 minutes at 50%.



Procedure	
<b>1</b>	<div style="display: flex; align-items: center; gap: 10px;"> <div style="text-align: center;"> <span style="font-size: 24px;">5</span> <span style="font-size: 24px;">0</span> <span style="font-size: 24px;">0</span> </div> <div>Enter cooking time for first stage. Touch POWER LEVEL pad twice for 100% power.</div> </div> <div style="margin-left: 20px;"> <div style="border: 1px solid black; padding: 5px; text-align: center;">POWER LEVEL</div> <div style="font-size: 24px;">x 2</div> </div>
<b>2</b>	<div style="display: flex; align-items: center; gap: 10px;"> <div style="border: 1px solid black; padding: 5px; text-align: center;">TIMER PAUSE</div> <div>Touch TIMER/PAUSE pad.</div> </div>
<b>3</b>	<div style="display: flex; align-items: center; gap: 10px;"> <div style="text-align: center;"> <span style="font-size: 24px;">3</span> <span style="font-size: 24px;">0</span> <span style="font-size: 24px;">0</span> </div> <div>Enter cooking program for second stage. Touch POWER LEVEL pad.</div> </div> <div style="margin-left: 20px;"> <div style="border: 1px solid black; padding: 5px; text-align: center;">POWER LEVEL</div> <div style="margin-top: 10px; text-align: center; font-size: 24px;">5</div> </div>
<b>4</b>	<div style="display: flex; align-items: center; gap: 10px;"> <div style="border: 1px solid black; padding: 5px; text-align: center;">START</div> <div>Touch START pad.</div> </div>
<b>5</b>	After the 1st stage, open door and stir. Close door.
<b>6</b>	<div style="display: flex; align-items: center; gap: 10px;"> <div style="border: 1px solid black; padding: 5px; text-align: center;">START</div> <div>Touch START pad.</div> </div>

## OTHER CONVENIENT FEATURES

### Auto Start

If you wish to program your oven to begin cooking automatically at a designated time of day, follow this procedure:

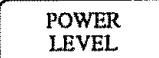
- Suppose you want to start cooking a stew for 20 minutes on 50% at 4:30. Before setting, check to make sure the clock is showing the correct time of day.

Procedure	
1	④ ③ ① Enter the start time.
2	 Touch AUTO START/CLOCK pad.
3	② ① ① ①  ⑤ Enter cooking program.
4	 Touch START pad.

- NOTE: 1. Auto Start can be used for **manual cooking** and **CompuCook**.
2. If the oven door is opened after programming Auto Start, it is necessary to touch the START pad for the time of day to appear in the readout so that the oven will automatically begin programmed cooking at the chosen Auto Start time.
  3. Be sure to choose foods that can be left in the oven safely until the Auto Start time. Baked potatoes are often a good choice.

### Audible Signal Elimination

If you wish to have the oven operate with no audible signals, touch AUTO START/CLOCK, the number ⑤ and START.

To cancel and restore the audible signal, touch AUTO START/CLOCK, the number ⑤ and STOP/CLEAR.

### More or Less Time Adjustment

#### More

Should you discover that you like any of the Instant Sensor, Sensor Cook, CompuCook or CompuDefrost settings slightly **more** done, touch the **POWER LEVEL** pad **once** after touching your choice of pads.

#### Less

Should you discover that you like any of the Instant Sensor, Sensor Cook, CompuCook or CompuDefrost settings slightly **less** done, touch the **POWER LEVEL** pad **twice** after touching your choice of pads.

The **POWER LEVEL** pad must be touched within 1 second of touching your choice of pads.



### Safety Lock

The Safety Lock prevents unwanted oven operation such as by small children.

The control panel can be deactivated or locked. To set, touch AUTO START/CLOCK, the number ① and START.  will appear in the display.

To cancel, touch AUTO START/CLOCK, the number ① and STOP/CLEAR.

### Demonstration Mode

To demonstrate, touch AUTO START/CLOCK, ⑥ and START.  will appear in the display. Cooking operations and special features can now be demonstrated with no power in the oven. For example, touch MINUTE PLUS and the display will show  and count down quickly to 0 and the "End".

To cancel, touch AUTO START/CLOCK, then ⑥ and STOP/CLEAR.

# SERVICE CALL CHECK

Please check the following before calling for service:

1. Place one cup of water in a glass measuring cup in the oven and close the door securely.  
Operate the oven for two minutes at HIGH 100%.
  - A. Does the light come on in the oven? YES \_\_\_\_\_ NO \_\_\_\_\_
  - B. Does the cooling fan work? YES \_\_\_\_\_ NO \_\_\_\_\_  
(Put your hand over the top ventilation openings.)
  - C. Does the turntable rotate when the TURNTABLE ON/OFF pad is touched and TURNTABLE ON is in the display? YES \_\_\_\_\_ NO \_\_\_\_\_  
(It is normal for the turntable to turn in either direction when TURNTABLE ON is in the display.)
  - D. Is the water in the oven hot? YES \_\_\_\_\_ NO \_\_\_\_\_

If "NO" is the answer to any of the above questions, please check electrical outlet, fuse and/or circuit breaker. If both are functioning properly, CONTACT YOUR NEAREST SHARP AUTHORIZED SERVICER. A microwave oven should never be serviced by a "do-it-yourself" repair person.

NOTE: If time appearing in the display is counting down very rapidly, check Demonstration Mode on page 20 and cancel.

# SPECIFICATIONS

AC Line Voltage:	Single phase 120V, 60Hz, AC only
AC Power Required:	1520 watts 14.0 amps.
Output Power:	850 watts* (IEC-705-1988 Test Procedure)
Frequency:	2450 MHz
Outside Dimensions:	29 7/8"(W) x 15 3/4"(H) x 14"(D)
Cavity Dimensions:	18 1/8"(W) x 7 3/4"(H) x 13 1/4"(D)
Oven Capacity:	1.1 Cu.Ft.
Cooking Uniformity:	Turntable / Stirrer Fan System
Weight:	Approx. 57 lbs.
Hood Light:	2 bulbs, (30 W x 2, incandescent light bulbs)
Hood Fan:	Horizontal discharge 237 C.F.M. Vertical discharge 230 C.F.M.

\* The International Electrotechnical Commission's standardized method for measuring output wattage. This test method is widely recognized.

In compliance with standards set by:

FCC – Federal Communications Commission Authorized.

DHHS – Complies with Department of Health and Human Services (DHHS) rule, CFR, Title 21, Chapter I, Subchapter J.



– This symbol on the nameplate means the product is listed by Underwriters Laboratories, Inc.

# CLEANING AND CARE

## Exterior

The outside surface is precoated metal and plastic. Clean the outside with mild soap and water; rinse and dry with a soft cloth. Do not use any type of household or abrasive cleaner.

## Door

Wipe the window on both sides with a damp cloth to remove any spills or spatters. Metal parts will be easier to maintain if wiped frequently with a damp cloth. Avoid the use of harsh abrasives.

## Touch Control Panel

Care should be taken in cleaning the touch control panel. If the control panel becomes soiled, open the oven door to inactivate the control panel before cleaning. Wipe the panel with a cloth dampened slightly with water only. Dry with a soft cloth. Do not scrub or use any sort of chemical cleaners. Avoid the use of excess water. Close door and touch STOP/CLEAR.

## Interior

Cleaning is easy because no heat is generated to the interior surfaces; therefore, there is no baking and setting of spills or spattering. To clean the interior surfaces, wipe with a soft cloth and warm water. **DO NOT USE ABRASIVE OR HARSH CLEANERS OR SCOURING PADS.** For heavier soil, use baking soda or a mild soap; rinse thoroughly with hot water. The turntable motor shaft is sealed, but excess water or spills should be wiped up immediately.

## Wave Guide Cover

Carefully wash any food particles from the wave guide cover located on the ceiling in the oven cavity.

## Odor Removal

Occasionally, a cooking odor may remain in the oven. To remove, combine 1 cup water, grated peel and juice of 1 lemon and several whole cloves in a 2-cup glass measuring cup. Boil for several minutes using 100% power. Allow to set in oven until cool. Wipe interior with a soft cloth.

## Turntable/Turntable Support

The turntable and turntable support can be removed for easy cleaning. Wash them in mild, sudsy water; for stubborn stains use a mild cleanser and scouring sponge as described above. They are also dishwasher-proof.

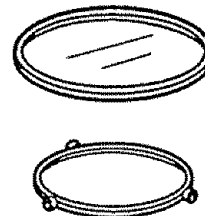

## Grease Filters

Filters should be cleaned at least once a month. Never operate the fan or oven without the filters in place.

1. Pull the tab toward the front of the oven, down slightly and remove the filter. Repeat for the other filter.
2. Soak the filters in a sink or dish pan filled with hot water and detergent.  
DO NOT use ammonia or other alkali; they will react with the filter material and darken it.
3. Agitate and scrub with a brush to remove embedded dirt.
4. Rinse thoroughly and shake dry.
5. Replace by fitting the filter back into the opening.

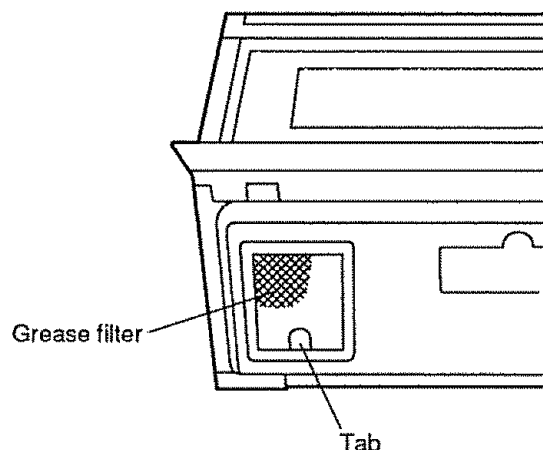

# CLEANING AND CARE

## Fan

The fan will automatically start when heat rises from range surface units or burners. This protects the microwave oven from excessive temperature rise. The fan will stay on until the temperature decreases. It cannot be turned off manually during this time.

For other uses, select either HI or LO speed.

## PRECAUTIONS FOR PROPER USE:

1. DO NOT leave range unattended while using high temperatures. Automatic fan may start and provide excessive air to the surface units. This may cause spattering or boilover.
2. Avoid burning food.
3. Keep grease filters clean.

## Light

1. To replace light bulbs, first disconnect power to the oven at the circuit breaker panel or by unplugging.
2. To release cover remove the screw on the light cover. (See illustration.)
3. Replace bulbs only with Sharp Part Number RLMPTA036WRE0 available from a Sharp Servicer or equivalent 30 watt bulb available at most hardware stores or lighting centers. DO NOT USE A BULB LARGER THAN 30 WATTS.
4. Close light cover and secure with screw removed in step 2.

**CAUTION:** Light cover may become very hot. Do not touch glass when light is on. Do not use light for long time use such as a night light.

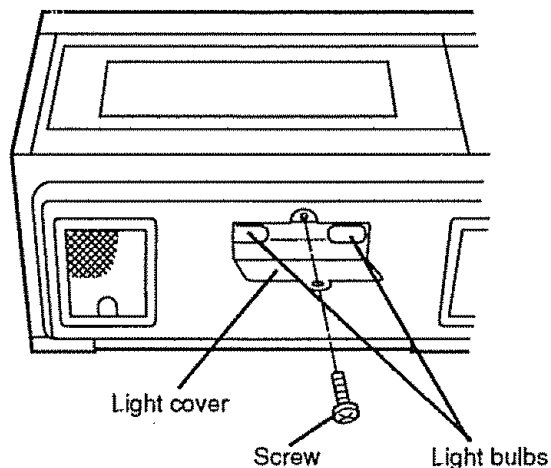

## Charcoal Filter Kit

Charcoal Filter Kit, Sharp Part Number RK-220 is used for non-vented, recirculated installation. The filter should be changed every 6 to 12 months depending on use.

1. Disconnect power to the oven at the circuit breaker panel or by unplugging.
2. Remove three louver mounting screws. (See illustration.)
3. Pull the louver away from the unit.
4. Change the charcoal filter.
5. Push louver back in place and replace the screws.

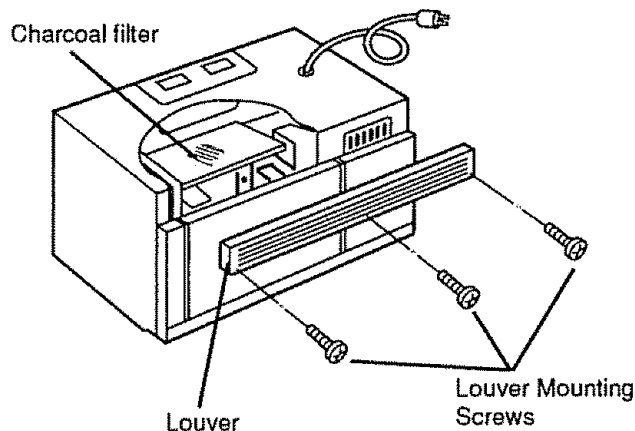

## Oven Light

Remove the louver per instructions 1 - 3 above and charcoal filter, if used.

4. Remove and save one Phillips head screw from oven light cover.
5. Remove old light bulb and replace only with Sharp Part Number RLMPTA030WRE0 available from Sharp Servicer, or equivalent 20 watt light bulb available from most hardware stores and lighting centers. DO NOT USE BULB LARGER THAN 20 WATTS.
6. Replace the oven light cover, Phillips head screw and charcoal filter, if used; push louver back in place and replace the louver mounting screws.



## Reheating Chart

Item	Starting Temperature	Microwave Time	Procedure
<b>Meat</b> (Chicken pieces, chops, hamburgers, meat loaf slices) 1 serving 2 servings	Refrigerated Refrigerated	MED.-HIGH (70%) 1-2 min. 2-4 min.	Cover loosely with plastic wrap.
<b>Meat Slices</b> (Beef, ham, pork, turkey) 1 or more servings	Room temp. Refrigerated	MEDIUM (50%) 1-1 3/4 min. per serving 1 1/2-2 1/2 min. per serving	Cover with gravy or wax paper. Check after 30 sec. per serving.
<b>Stirrable Casseroles and Main Dishes</b> 1 serving 2 servings 4-6 servings	Refrigerated Refrigerated Refrigerated	HIGH (100%) 1 3/4-3 1/2 min. 3 3/4-5 min. 6 1/2-7 1/2 min.	Cover with plastic wrap and stir after half the time.
<b>Nonstirrable Casseroles and Main Dishes</b> 1 serving 2 servings 4-6 servings	Refrigerated Refrigerated Refrigerated	MEDIUM (50%) 4 1/2-7 1/2 min. 7 1/2-11 min. 12-15 min.	Cover with wax paper.
<b>Vegetables</b> 1 serving 2 servings	Refrigerated Refrigerated	HIGH (100%) 3/4-1 1/4 min. 1 1/2-2 min.	Cover. Stir after half the time.
<b>Baked Potato</b> 1 2	Refrigerated Refrigerated	HIGH (100%) 1-2 1/2 min. 2 1/2-3 min.	Cut potato lengthwise and then several times crosswise. Cover with wax paper.
<b>Pie</b> 1 slice 2 slices	Refrigerated Refrigerated	HIGH (100%) 30-45 sec. 1-1 1/2 min.	Place on microwave-safe dish. Do not cover.
After reheating, food should be very hot-165°F. If possible, stir food, cover and allow to stand two to three minutes before serving.			

## Fish and Seafood Cooking Chart

Cut	Cooking Preparation	Microwave Procedure	Standing Time
<b>FILLETS</b>	Pie plate or casserole. Cover with plastic wrap.	MED-HIGH (70%) 4-6 min. per lb.	3 min.
<b>STEAKS</b>	Pie plate or casserole. Cover with plastic wrap. Turn over halfway through cooking time.	MED-HIGH (70%) 5-7 min. per lb.	3 min.
<b>SHRIMP &amp; SCALLOPS</b>	Pie plate or casserole. Cover with plastic wrap. Turn over halfway through cooking time.	MED-HIGH (70%) 4-6 min. per lb.	1-2 min.

# Meat and Poultry Roasting Chart

Cut	Cooking Preparation	Microwave Procedure	Internal Temp. at Removal	Internal Temp. after Standing
<b>BEEF</b>				
Rolled Rib Boneless (4-6 lbs.)	Meat roasting rack. Cover with plastic wrap. Turn over halfway through cooking time.	MED. (50%) Rare: 7-9 min. per lb. Med.: 9½-11 min. per lb. Well: 12-14 min. per lb.	120°F 135°F 150°F	130°F 145°F 160°F
Chuck or Pot Roast (cook in ½ cup liquid) (2-3 lbs.)	Large covered casserole. Turn over halfway through cooking time.	MED. (50%)	150°F	160°F
Without vegetables		21-24 min. per lb.		
With 3-4 cups cut-up vegetables		27-30 min. per lb.		
Eye of Round (2-3 lbs.)	Rack. Cover with plastic wrap. Turn over halfway through cooking time.	MED. (50%) Rare: 5-8 min. per lb. Med.: 7-10 min. per lb. Well: 9-11 min. per lb.	120°F 135°F 150°F	130°F 145°F 160°F
Ground Meat (to brown for casserole)	Casserole. Cover with plastic wrap. Stir halfway through cooking time.	HIGH (100%) 4-6 min. per lb.	155°F	160°F
Hamburgers (¼ lb. each) 2 patties 4 patties	Rack. Cover with wax paper. Turn over halfway through cooking time.	HIGH (100%)  3-4 min. 4-6 min.		
<b>PORK</b>				
Loin Roast Boneless	Meat roasting rack. Cover with plastic wrap. Turn over halfway through cooking time.	MED.-HIGH (70%) 7-11 min. per lb. MED. (50%) 12-14 min. per lb.	160°F 160°F	170°F 170°F
Tenderloin	Same procedure as above.	MED.-LOW (30%) 13-17 min. per lb.	160°F	170°F
Bacon 2 slices 4 slices 6 slices	Place bacon between paper towels on paper plate or on a rack.	HIGH (100%) 1½-2 min. 2½-3½ min. 3½-4½ min.		
<b>CHICKEN</b>				
Whole	Breast side down on rack. Cover with plastic wrap. Turn over halfway through cooking time.	MED.-HIGH (70%) 5-8 min. per lb.	170°F	180°F
Pieces Bone-in Boneless	Rack. Cover with plastic wrap. Turn over halfway through cooking time.	HIGH (100%) 5-7½ min. per lb. 4-7 min. per lb.	170°F 160°F	180°F 170°F
<b>TURKEY</b>				
Whole (up to 10 lbs.)	Breast side down on rack. Cover with plastic wrap. Turn over halfway through cooking time.	MED. (50%) 10-14 min. per lb.	170°F	180°F
Breast Bone-in Boneless	Rack. Cover with plastic wrap. Turn over halfway through cooking time.	MED. (50%) 11-15 min. per lb. 14-18 min. per lb.	160°F 160°F	170°F 170°F

## Vegetable Cooking Chart













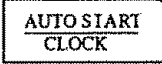

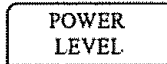



Vegetable	Amount	Cooking Procedure	Microwave Time at HIGH (100%)	Standing Time, Covered
<b>Artichokes</b> Fresh	2 medium	Trim and rinse. 2-qt. casserole. 2 tbsp. water. Cover with plastic wrap.	5-8 min.	5 min.
<b>Asparagus</b> Fresh Spears	1 lb.	2-qt. casserole. 2 tbsp. water. Cover. Rearrange after 3 min.	4-7 min.	2 min.
<b>Beans</b> Fresh, Green and Wax	1 lb.	1 1/2-in. pieces. 2-qt. casserole. 1/4 cup water. Cover. Stir twice.	9-13 min.	2 min.
<b>Beets</b> Fresh, Whole	5 medium	Wash. Leave 1 inch of tops. 2-qt. casserole. 1/4 cup water. Cover. Stir every 5 min.	12-18 min.	3 min.
<b>Broccoli</b> Fresh, Spears	1 lb.	Wash. 2-qt. casserole. Add no water. Cover. Rearrange after 3 min. Uncover during stand.	6-8 min.	3 min. <b>uncovered</b>
	Fresh, Pieces	1 lb. Wash. 2-qt. casserole. Add no water. Cover. Stir after 3 min. Uncover during stand.	5-7 min.	2 min. <b>uncovered</b>
<b>Cabbage</b> Shredded	1 lb.	2-qt. casserole. 2 tbsp. water. Cover. Stir after 4 min.	8-12 min.	2 min.
	Wedges	1 lb. 2-qt. casserole. 2 tbsp. water. Cover. Rearrange after 5 min.	12-14 min.	3 min.
<b>Carrots</b> Fresh, Slices	2 cups	1-qt. casserole. 2 tbsp. water. Cover. Stir after 3 min.	5-8 min.	3 min.
<b>Cauliflower</b> Fresh, Flowerets	2 cups	1-qt. casserole. 1 tbsp. water. Cover. Stir after 2 min.	3-5 min.	2 min.
	Fresh, Whole	1 1/2 lbs. Remove leaves and core center. 2-qt. casserole. 2 tbsp. water. Cover.	7-9 min.	3 min.
<b>Corn</b> Fresh, on Cob	2 ears	9-in. pie plate. 2 tbsp. water. Cover. Rearrange after 4 min.	6-9 min. 12-14 min.	5 min. 5 min.
	4 ears	2-qt. oval or rectangular casserole. 1/4 cup water. Cover.	6-8 min. 10-12 min.	5 min. 5 min.
<b>Peas, Green</b> Fresh	2 cups	1-qt. casserole. 1/4 cup water. Cover. Stir after 3 min.	4-6 min.	3 min.
<b>Potatoes</b> Boiled	4 medium	Peel and quarter potatoes. 2-qt. casserole. Cover. Stir after 5 min.	9-12 min.	3 min.
<b>Spinach</b> Fresh	1 lb.	Wash and trim. Add no water. 3-qt. casserole. Cover. Stir after 3 min.	5-7 min.	2 min.
<b>Squash</b> Fresh, Acorn	1 whole	Prick; place on paper towel. Turn over after 4 min.	7-10 min.	5 min.
	Fresh, Sliced Zucchini	2 cups 1-qt. casserole. Add no water. Cover. Stir after 2 min.	2-4 min.	1 min.
	Frozen, Mashed	10-oz. pkg. 1-qt. casserole. Add no water. Cover. Break apart and stir after 3 min.	6-8 min.	2 min.
<b>Sweet Potatoes</b> Baked	2 medium 4 medium	Prick; place on paper towels. Turn over, rearrange after 5 min.	5-9 min. 10-13 min.	5 min. 5 min.



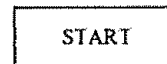

# AUTO-TOUCH® GUIDE

For more complete information and safety precautions, refer to the inside instructions.

<p><b>SET CLOCK</b> If 88:88 is in display, first touch STOP/CLEAR.</p> <ol style="list-style-type: none"> <li>1. Touch AUTO START/CLOCK pad.</li> <li>2. Enter correct time of day by touching numbers in sequence. (Ex: 12:30)</li> <li>3. Touch AUTO START/CLOCK pad again.</li> </ol>	  	<p><b>MANUAL OPERATION</b></p> <p><b>High Power Cooking</b></p> <ol style="list-style-type: none"> <li>1. Enter cooking time by touching number pads. (Ex: 1 min. 30 sec.)</li> <li>2. Touch START.</li> </ol> <p><b>Variable Power Cooking</b></p> <ol style="list-style-type: none"> <li>2. After Step 1 above, touch POWER LEVEL pad.</li> <li>3. Select power level (Ex: 5 for 50%) and START.</li> </ol>	    																										
<p><b>COMPU COOK</b></p> <ol style="list-style-type: none"> <li>1. Touch COMPU COOK pad.</li> <li>2. Select desired CompuCook setting. (Ex: Touch 1 to warm frozen muffins.)</li> <li>3. Touch number pad for quantity. (Ex: 2 for two frozen muffins.)</li> <li>4. Touch START.</li> </ol>	   	<p><b>COMPU DEFROST</b></p> <ol style="list-style-type: none"> <li>1. Touch COMPU DEFROST pad for a .5 lb. increase per touch. (Ex: 2.5 lbs. steak.)</li> <li>2. During defrosting, oven will stop. Check food. Touch START to continue defrosting.</li> </ol>	 x 5 																										
<table border="1"> <tbody> <tr> <td>1</td> <td>Roll/muffin, frozen</td> <td>1 to 6 pieces</td> </tr> <tr> <td>2</td> <td>Roll/muffin, fresh</td> <td>1 to 6 pieces</td> </tr> <tr> <td>3</td> <td>Chicken pieces</td> <td>0.5 to 3.5 lbs.</td> </tr> <tr> <td>4</td> <td>Roast pork</td> <td>2.0 to 3.5 lbs.</td> </tr> <tr> <td>5</td> <td>Turkey breast</td> <td>3.0 to 6.0 lbs.</td> </tr> <tr> <td>6</td> <td>Rice</td> <td>0.5 to 2.0 cups</td> </tr> </tbody> </table>	1	Roll/muffin, frozen	1 to 6 pieces	2	Roll/muffin, fresh	1 to 6 pieces	3	Chicken pieces	0.5 to 3.5 lbs.	4	Roast pork	2.0 to 3.5 lbs.	5	Turkey breast	3.0 to 6.0 lbs.	6	Rice	0.5 to 2.0 cups	<table border="1"> <tbody> <tr> <td>Roast</td> <td>2.5 to 6.0 lbs.</td> </tr> <tr> <td>Steaks, chops, fish</td> <td>0.5 to 4.0 lbs.</td> </tr> <tr> <td>Ground meat</td> <td>0.5 to 3.0 lbs.</td> </tr> <tr> <td>Chicken, whole</td> <td>2.5 to 6.0 lbs.</td> </tr> <tr> <td>Chicken pieces</td> <td>0.5 to 3.0 lbs.</td> </tr> </tbody> </table>	Roast	2.5 to 6.0 lbs.	Steaks, chops, fish	0.5 to 4.0 lbs.	Ground meat	0.5 to 3.0 lbs.	Chicken, whole	2.5 to 6.0 lbs.	Chicken pieces	0.5 to 3.0 lbs.
1	Roll/muffin, frozen	1 to 6 pieces																											
2	Roll/muffin, fresh	1 to 6 pieces																											
3	Chicken pieces	0.5 to 3.5 lbs.																											
4	Roast pork	2.0 to 3.5 lbs.																											
5	Turkey breast	3.0 to 6.0 lbs.																											
6	Rice	0.5 to 2.0 cups																											
Roast	2.5 to 6.0 lbs.																												
Steaks, chops, fish	0.5 to 4.0 lbs.																												
Ground meat	0.5 to 3.0 lbs.																												
Chicken, whole	2.5 to 6.0 lbs.																												
Chicken pieces	0.5 to 3.0 lbs.																												
<p><b>INSTANT SENSOR</b> Touch INSTANT SENSOR pad. (Ex: POPCORN)</p>		<p><b>MINUTE PLUS</b> Touch MINUTE PLUS for one minute at 100% power or to add minute to cooking. Continue to touch for additional minutes.</p>																											
<table border="1"> <tbody> <tr> <td>Frozen Entree</td> <td>6-16 oz.</td> </tr> <tr> <td>Sensor Reheat</td> <td></td> </tr> <tr> <td>  Leftovers</td> <td>4-32 oz.</td> </tr> <tr> <td>  Soups</td> <td>1-4 cups</td> </tr> <tr> <td>  Canned entrees and vegetables</td> <td>4-16 oz.</td> </tr> <tr> <td>  Hot dogs</td> <td>1-2</td> </tr> <tr> <td>  Dinner plate</td> <td>1 plate</td> </tr> <tr> <td>Popcorn</td> <td>Only 1 package</td> </tr> <tr> <td>Baked potatoes</td> <td>1-6 medium</td> </tr> </tbody> </table>	Frozen Entree	6-16 oz.	Sensor Reheat		Leftovers	4-32 oz.	Soups	1-4 cups	Canned entrees and vegetables	4-16 oz.	Hot dogs	1-2	Dinner plate	1 plate	Popcorn	Only 1 package	Baked potatoes	1-6 medium	<p><b>SENSOR COOK</b></p> <ol style="list-style-type: none"> <li>1. Touch SENSOR COOK pad.</li> <li>2. Select desired SENSOR COOK setting. (Ex: Touch 4 to cook bacon.)</li> <li>3. Touch START.</li> </ol>	  									
Frozen Entree	6-16 oz.																												
Sensor Reheat																													
Leftovers	4-32 oz.																												
Soups	1-4 cups																												
Canned entrees and vegetables	4-16 oz.																												
Hot dogs	1-2																												
Dinner plate	1 plate																												
Popcorn	Only 1 package																												
Baked potatoes	1-6 medium																												
<p>Carousel and Auto-Touch are registered trademarks of Sharp Electronics Corporation.</p> <p><b>SHARP</b></p> <p>SHARP ELECTRONICS CORPORATION Sharp Plaza, Mahwah, New Jersey 07430-2135</p> <p>TINSEB103MRR0-B Printed in U.S.A.</p>	<table border="1"> <tbody> <tr> <td>1</td> <td>Fresh vegetables, soft</td> <td>0.25 to 2.0 lbs.</td> </tr> <tr> <td>2</td> <td>Fresh vegetables, hard</td> <td>0.25 to 1.5 lbs.</td> </tr> <tr> <td>3</td> <td>Frozen vegetables</td> <td>1 to 6 cups</td> </tr> <tr> <td>4</td> <td>Bacon</td> <td>2 to 6 slices</td> </tr> <tr> <td>5</td> <td>Fish, seafood</td> <td>0.25 to 2.0 lbs.</td> </tr> <tr> <td>6</td> <td>Ground meat</td> <td>0.3 to 2.0 lbs.</td> </tr> </tbody> </table>	1	Fresh vegetables, soft	0.25 to 2.0 lbs.	2	Fresh vegetables, hard	0.25 to 1.5 lbs.	3	Frozen vegetables	1 to 6 cups	4	Bacon	2 to 6 slices	5	Fish, seafood	0.25 to 2.0 lbs.	6	Ground meat	0.3 to 2.0 lbs.										
1	Fresh vegetables, soft	0.25 to 2.0 lbs.																											
2	Fresh vegetables, hard	0.25 to 1.5 lbs.																											
3	Frozen vegetables	1 to 6 cups																											
4	Bacon	2 to 6 slices																											
5	Fish, seafood	0.25 to 2.0 lbs.																											
6	Ground meat	0.3 to 2.0 lbs.																											