

**SHARP®**

**SERVICE MANUAL**

S98M121R1850A

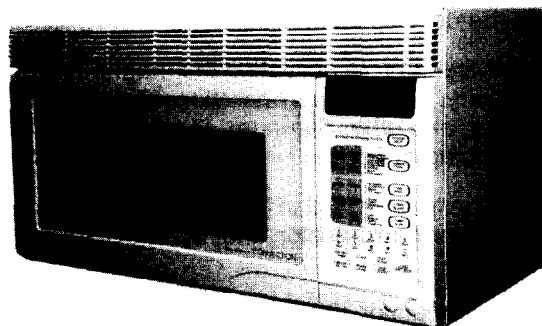

Model R-1851A

**OVER THE RANGE  
MICROWAVE OVENS  
R-1850A/R-1851A/R-1852A**

In the interest of user-safety the oven is to be restored to its original condition and only the parts identical to those specified should be used.

This is a supplemental Service Manual for Models R-1850A/R-1851A/R-1852A. This model is quite similar to the Base Model R-1850 (S/M# S6804R1850X//). Use this supplemental manual together with the Base Model Service Manuals for complete operation and service information.

**TABLE OF CONTENTS**

SECTION	PAGE
PRECAUTIONS TO BE OBSERVED BEFORE AND DURING SERVICE TO AVOID POSSIBLE EXPOSURE TO EXCESSIVE MICROWAVE ENERGY. . . . .	Inside Front Cover
Before Servicing . . . . .	Inside Front Cover
Foreword and Warning . . . . .	1
Warning to Service Personnel . . . . .	2
Microwave Measurement Procedure . . . . .	3
Wiring/Schematic Diagram . . . . .	4
Parts . . . . .	6
Packing and Accessories . . . . .	13

**SHARP ELECTRONICS CORPORATION**

Service Headquarters: Sharp Plaza, Mahwah, New Jersey, 07430-2135

## PRECAUTIONS TO BE OBSERVED BEFORE AND DURING SERVICING TO AVOID POSSIBLE EXPOSURE TO EXCESSIVE MICROWAVE ENERGY.

- (a) Do not operate or allow the oven to be operated with the door open.
- (b) Make the following safety checks on all ovens to be serviced before activating the magnetron or other microwave source, and make repairs as necessary: (1) Interlock operation, (2) proper door closing, (3) seal and sealing surfaces (arcing, wear, and other damage), (4) damage to or loosening of hinges and latches, (5) evidence of dropping or abuse.
- (c) Before turning on microwave power for any service test or inspection within the microwave generating compartments, check the magnetron, waveguide or transmission line, and cavity for proper alignment, integrity, and connections.
- (d) Any defective or misadjusted components in the interlock, monitor, door seal, and microwave generation and transmission systems shall be repaired, replaced, or adjusted by procedures described in this manual before the oven is released to the owner.
- (e) A microwave leakage check to verify compliance with the Federal performance standard should be performed on each oven prior to release to the owner.

(RD21101U)

## BEFORE SERVICING

Before servicing an operative unit, perform a microwave emission check as per the Microwave Measurement Procedure outlined in the base model service manual. If microwave emissions level is in excess of the specified limit, contact SHARP ELECTRONICS CORPORATION immediately @ 1-800-237-4277.

If the unit operates with the door open, service person should 1) tell the user not to operate the oven and 2) contact SHARP ELECTRONICS CORPORATION and DHHS immediately.

Service personnel should inform SHARP ELECTRONICS CORPORATION of any certified unit found with emissions in excess of  $4\text{mW}/\text{cm}^2$ . The owner of the unit should be instructed not to use the unit until the oven has been brought into compliance.

(RD81001U)

# SERVICE MANUAL

## SHARP®

### Over The Range Microwave Ovens R-1850A/R-1851A/R-1852A Foreword

This manual has been prepared to provide Sharp Electronics Corporation personnel with complete operation and service information for Sharp microwave oven models R-1850A/R-1851A/R-1852A

It is recommended that service personnel carefully study the entire text of this manual so they will be qualified to render satisfactory customer service.

Check interlock switches and the door seal carefully. Special attention must be given to avoid electrical shock and microwave radiation hazards.

### NOTE

This supplemental service manual contains update information only. Please refer to base model service manual (R-1850) for complete service information.

### WARNING

Never operate the oven until the following points are ensured:

- (A) The door is tightly closed.
- (B) The door brackets and hinges are not defective.
- (C) The door packing is not damaged.
- (D) The door is not deformed or warped.
- (E) There are no other visible signs of damage to the oven.

### DANGER

**Certain initial parts are intentionally not grounded and present a risk of electrical shock only during servicing. Service personnel - Do not contact the following parts while the appliance is energized; High Voltage Capacitor, Power Transformer, Magnetron, High Voltage Rectifier Assembly and High voltage Harness.**

**If provided, Vent Hood, Fan Assembly and Cooling Fan motor.**

All of the parts marked "\*" on parts list are used at voltages more than 250V.

Removal of the outer case cabinet gives access to voltage above 250V.

All of the parts marked "Δ" on parts list may cause undue microwave exposure, by themselves, or when they are damaged, loosened or removed.

**Sharp Electronics Corporation  
Sharp Plaza  
Mahwah, New Jersey 07430-2135**

Microwave Measurement

Schematic / Wiring Diagram

Parts

## WARNING TO SERVICE PERSONNEL

Microwave ovens contain circuitry capable of producing very high voltage and current. Contact with following parts may result in a severe, possibly fatal, electrical shock.

(EXAMPLE)

High Voltage Capacitor, High Voltage Power Transformer, Magnetron, High Voltage Rectifier Assembly, High Voltage Harness etc..  
Read the Service Manual carefully and follow all instructions.

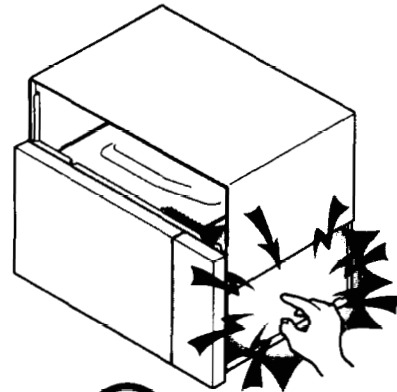

**Don't Touch !  
Danger High Voltage**

### Before Servicing

1. Disconnect the power supply cord and then remove outer case cabinet.
2. Open the door and block it open.
3. Discharge the high voltage capacitor.

**WARNING: RISK OF ELECTRICAL SHOCK. DISCHARGE THE HIGH VOLTAGE CAPACITOR BEFORE SERVICING.**

The high-voltage capacitor remains charged about 60 seconds after the oven has been switched off. Wait for 60 seconds and then short-circuit the connection of the high voltage capacitor (that is the connecting lead of the high voltage rectifier) against the chassis with the use of an insulated screwdriver.

Whenever troubleshooting is performed, the power supply must be disconnected. In some cases it may be necessary to connect the power supply after the outer case has been removed, in this event:

1. Disconnect the power supply cord and then remove outer case cabinet.
2. Open the door and block it open.
3. Discharge the high voltage capacitor.
4. Disconnect the leads to the primary of the power transformer.
5. Ensure that the leads remain isolated from other components and oven chassis by using insulation tape.
6. After the above procedure, reconnect the power supply cord.

### When the testing is completed

1. Disconnect the power supply cord and then remove outer case cabinet.
2. Open the door and block it open.
3. Discharge the high voltage capacitor.
4. Reconnect the leads to the primary of the power transformer.
5. Re-install the outer case cabinet.
6. Reconnect the power supply cord after the outer case cabinet is installed.
7. Start the oven and check all functions.

### After repairing

1. Reconnect all leads removed from components during testing.
2. Re-install the outer case (cabinet).
3. Reconnect the power supply cord after the outer case is installed.
4. Reconnect the power supply cord after the outer case is installed.
5. Run the oven and check all functions.

Microwave ovens should not be operated empty. To test for the presence of microwave energy within a cavity, place a cup of cold water on the oven turntable, close the door and set the power to HIGH and set the microwave timer for two (2) minutes. When the two minutes has elapsed (timer at zero), carefully check to see if the water is hot. If the water remains cold, carry out **Before Servicing** procedure and re-examine the connection to the component being tested.

When all service work is completed and the oven is fully assembled, the microwave power output should be checked and the microwave leakage test should be carried out.

# MICROWAVE MEASUREMENT PROCEDURE

After adjustment of the door, interlock and monitor switches are completed individually or collectively, a **INTERLOCK SWITCH TEST** and **MICROWAVE LEAKAGE TEST** must be performed to assure compliance with DHHS (CDRH) Performance Standards for Microwave Ovens.

## Interlock Switch Test

Make sure that the door sensing switch, secondary interlock switch and monitor switch are operating properly by checking with an ohmmeter.

Refer to the "Test Procedure" of the door sensing switch, secondary interlock switch and monitor switch.

## Microwave Leakage Test

### Requirements

1. Microwave leakage limit (Power density limit).  
The power density of microwave radiation emitted by a microwave oven shall not exceed  $1 \text{ mW/cm}^2$  at any point 5cm or more from the external surface of the oven, measured prior to acquisition by the purchaser, and thereafter (through the useful life of the oven)  $5 \text{ mW/cm}^2$  at any point 5cm or more from the external surface of the oven.
2. Safety interlock switches.  
Primary interlock relay and door sensing switch will prevent microwave radiation emissions in excess of the requirement as above mentioned, secondary interlock switch shall prevent microwave radiation emission in excess of  $5 \text{ mW/cm}^2$  at any point 5cm or more from the external surface of the oven.

### Preparation For Testing

Before beginning the actual measurement of leakage, proceed as follows:

1. Make sure that the actual instrument is operating normally as specified in its instruction booklet.

**Note:** Survey instruments that comply with the requirement for instrumentatoin 21CFR1030.10(c)(3)(i), as prescribed by the performance standard for microwave ovens must be used for testing.

2. Place the oven tray in the oven cavity.
3. Place the load of  $275 \pm 15 \text{ ml}$  (9.8 oz.) of tap water initially at  $20 \pm 5^\circ \text{C}$  ( $68^\circ \text{F}$ ) in the center of the oven cavity.  
The water container shall be a low form of 600 ml (20 oz.) beaker with an inside diameter of approximately 8.5 cm ( $3 \frac{1}{2}$  in.) and made of an electrically nonconductive material such as glass or plastic.  
The placing of this standard load in the oven is important not only to protect the oven, but also to insure that any leakage is measured accurately.
4. Set the cooking control on Full power cooking mode.
5. Close the door and put the oven into a cook cycle for several minutes. If the water begins to boil before the survey is completed, replace it with 275ml of cool water.

### Leakage Test

Closed-door leakage test (microwave measurement).

1. Grasp the probe of the survey instrument and hold it perpendicular to the gap between the door and the body of the oven.
2. Move the probe slowly, not faster than 1in./sec ( $2.5 \text{ cm/sec.}$ ) along the gap, watching for the maximum indication of the meter.
3. Check for leakage at the door screen, sheet metal seams and other accessible positions where the continuity of the metal has been breached (eg., around switches, indicator and vents).  
While testing for leakage around the door pull the door away from the front of the oven as far as is permitted by the closed latch assembly.
4. Measure carefully at the point of the highest leakage and make sure that the highest leakage is no greater than  $4 \text{ mW/cm}^2$  to allow for measurement uncertainty, and that the secondary interlock switch does turn the oven OFF before any door movement.

**Note:** After servicing, record data on service invoice and microwave leakage report.

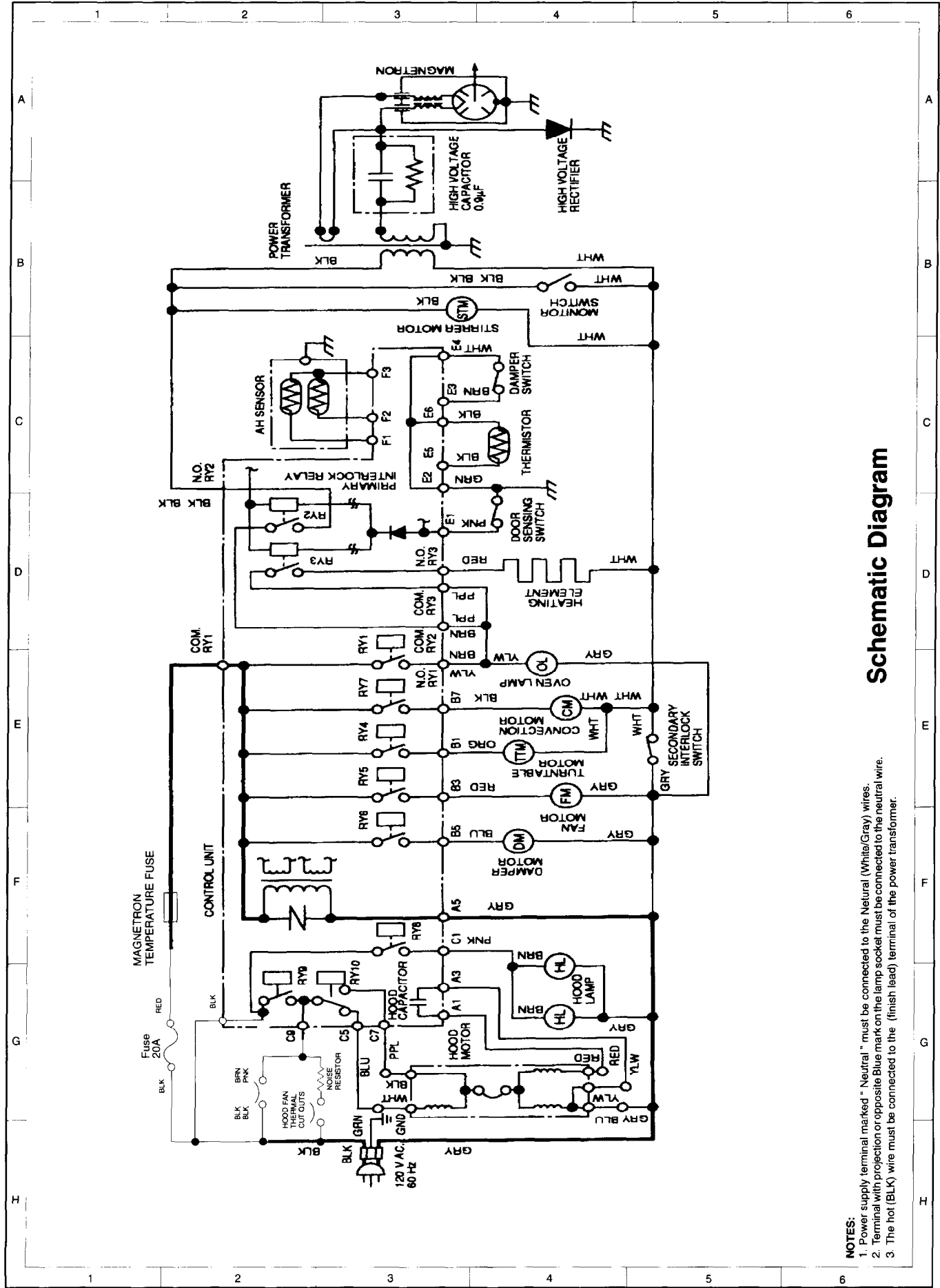

# Schematic Diagram

- NOTES:**
1. Power supply terminal marked "Neutral" must be connected to the Neutral (Whites/Gray) wires.
  2. Terminal with projection or opposite Blue mark on the lamp socket must be connected to the neutral wire.
  3. The hot (BLK) wire must be connected to the (finish lead) terminal of the power transformer.

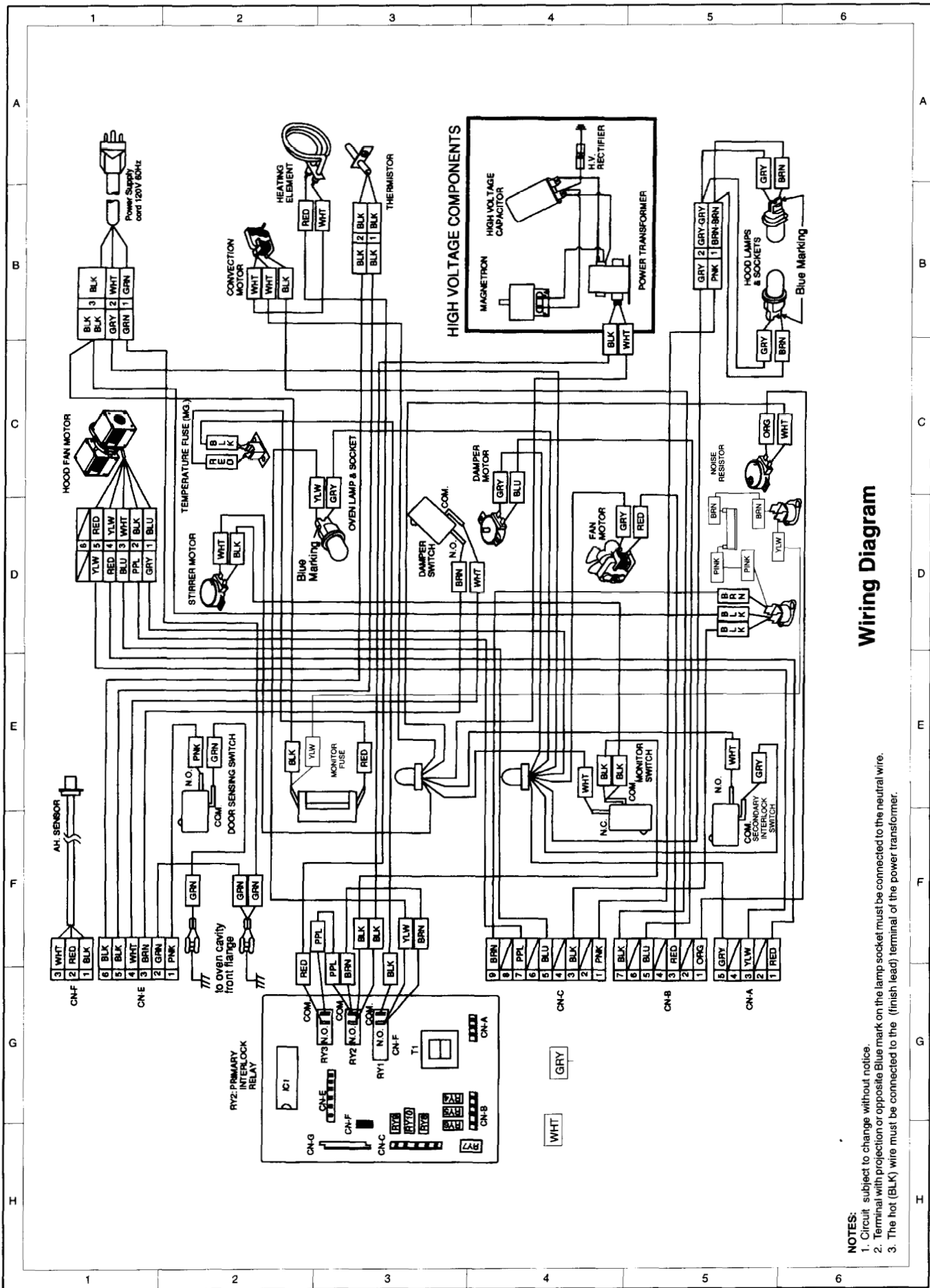

### Wiring Diagram

- NOTES:**
1. Circuit subject to change without notice.
  2. Terminal with projection or opposite Blue mark on the lamp socket must be connected to the neutral wire.
  3. The hot (BLK) wire must be connected to the (finish lead) terminal of the power transformer.

## PARTS LIST

Contact your nearest SHARP Parts Distributor to order.  
For location of SHARP Parts Distributor, Please call Toll-Free;  
1-800-BE-SHARP

"§" MARK – Spare parts delivery section.

REF NO.	PART NO.	§	DESCRIPTION	Q'TY	CODE
<b>ELECTRICAL PARTS</b>					
* 1- 1	FH-DZB010MRY0	M	H.V. Rectifier assembly	1	AM
* 1- 2	RC-QZB011MRE0	M	H.V. Capacitor	1	AR
1- 3	QFS-TA013WRE0	M	Oven temperature fuse (150°C)	1	AG
1- 4	RHET-A174WRE0	M	Convection heater	1	AZ
1- 5	RMOTDA182WRE0	M	Turntable motor	1	AQ
1- 6	RMOTDA214WRE0	M	Stirrer motor	1	AQ
1- 7	RTHM-0044MRE0	M	Thermal cut-out N.O. 60°C	2	AG
* 1- 8	RTRN-B049MRE0	M	Power transformer	1	BF
* Δ 1- 9	RV-MZA255WRE0	M	Magnetron	1	BE
1-10	QFSHDB003MRE0	M	Fuse holder	1	AD
1-11	QSW-MA110WRE0	M	Secondary interlock, Door sensing & damper switches	3	AE
1-12	FFS-BA016/KIT	M	Monitor switch and fuse assembly	1	AF
1-13	FACCCB011MRE0	M	Power supply cord	1	AP
1-14	QSOCLB006MRE0	M	Hood lamp socket & Oven lamp socket	2	AE
1-15	FH-HZA053WRE0	M	Thermistor	1	AP
1-16	QSOCLB006MRE0	M	Oven lamp socket	1	AE
1-17	FMOTEA362WRK0	M	Hood fan motor	1	BM
1-18	RMOTEA343WRE0	M	Convection motor	1	AX
1-19	RMOTEA344WRE0	M	Fan motor	1	AW
1-20	RLMPTA077WRE0	M	Hood lamp & Oven lamp	3	AG
1-21	FDTCTA171WRK0	M	AH sensor	1	AW
1-22	RMOTDA217WRE0	M	Damper motor	1	AP
1-23	RR-WZA031WRE0	M	Noise Resistor	1	AK
<b>CABINET PARTS</b>					
2- 1	PFIL-B002MRE0	M	Grease filter	2	AF
2- 2	PDIF-B011MRF0	M	Hood exhaust louver R-1850A	1	AV
2- 2	PDIF-B012MRF0	M	Hood exhaust louver R-1851A	1	AV
2- 2	PDIF-B013MRF0	M	Hood exhaust louver R-1852A	1	AV
2- 3	GDAI-B052MRP0	M	Base plate right	1	AL
2- 4	GDAI-B039MRP0	M	Base plate left	1	AH
2- 5	GCABUB065MRP0	M	Outer case cabinet R-1850A	1	BE
2- 5	GCABUB066MRP0	M	Outer case cabinet R-1851A	1	BE
2- 5	GCABUB079MRP0	M	Outer case cabinet R-1852A	1	BE
2- 6	TMAPCB056MRR0	M	Schematic diagram	1	AB
2- 7	FANGKB009MRY0	M	Hood lamp glass assembly R-1850A	1	AM
2- 7	FANGKB010MRY0	M	Hood lamp glass assembly R-1851A	1	AM
2- 7	FANGKB011MRY0	M	Hood lamp glass assembly R-1852A	1	AM
2-7-1	LANGQB016MRP0	M	Hood lamp glass angle R-1850A	1	AG
2-7-1	LANGQB020MRP0	M	Hood lamp glass angle R-1851A	1	AG
2-7-1	LANGQB027MRP0	M	Hood lamp glass angle R-1852A	1	AG
2-7-2	PGLSPB004MRE0	M	Hood lamp glass	1	AG
2- 8	PCOVPB051MRP0	M	Base cover	1	AY
2- 9	HDECQB016MRF0	M	Sash left	1	AL
2-10	LSTY-B010MRP0	M	Rear stay	1	AG



REF NO.	PART NO.	§	DESCRIPTION	Q'TY	CODE
<b>CONTROL PANEL PARTS</b>					
3-1	DPWFB061MRU0	M	Control unit	1	BQ
3-1A	QCNCMA227DRE0	J	3-pin connector (CN-A)	1	AC
3-1B	QCNCMA230DRE0	J	4-pin connector (CN-B)	1	AC
3-1C	QCNCMA234DRE0	J	5-pin connector (CN-C)	1	AC
3-1D	QCNCMA267DRE0	J	6-pin connector (CN-E)	1	AC
3-1E	QCNCMA237DRE0	J	3-pin connector (CN-F)	1	AD
3-1F	QCNCWA030DRE0	J	12-pin connector (CN-G)	1	AE
3-1G	RV-KXB003MRE0	M	Fluorescent display tube	1	AV
3-1H	PTPEHB010MRE0	M	Tape 2mm	1	AB
C1	RC-KZA087DRE0	J	Capacitor 0.1 $\mu$ F 50V	1	AB
C2	VCEAB31VW108M	J	Capacitor 1000 $\mu$ F 35V	1	AF
C3	RC-KZA087DRE0	J	Capacitor 0.1 $\mu$ F 50V	1	AB
C4	VCEAB31VW106M	J	Capacitor 10 $\mu$ F 35V	1	AB
C5	RC-KZA087DRE0	J	Capacitor 0.1 $\mu$ F 50V	1	AB
C6	VCEAB31VW106M	J	Capacitor 10 $\mu$ F 35V	1	AB
C7-8	VCKYD11CY103N	J	Capacitor 0.01 $\mu$ F 16V	2	AH
C9-10	RC-KZA087DRE0	J	Capacitor 0.1 $\mu$ F 50V	2	AB
C20	VCEAB31VW106M	J	Capacitor 10 $\mu$ F 35V	1	AB
C21	VCEAB31HW104M	J	Capacitor 0.1 $\mu$ F 50V	1	AM
C30	VCKYD11CY103N	J	Capacitor 0.01 $\mu$ F 16V	1	AH
C50	VCKYD11CY103N	J	Capacitor 0.01 $\mu$ F 16V	1	AH
C60	VCKYD11CY103N	J	Capacitor 0.01 $\mu$ F 16V	1	AH
C70-74	VCKYD11HB331K	J	Capacitor 330 $\rho$ F 50V	5	AA
C100	RC-QZB014MRE0	M	Capacitor 7 $\mu$ F 230V	1	AM
CF1	RCRS-A010DRE0	J	Ceramic resonator (CST4.00MGW)	1	AD
D1-4	VHD11ES1///-1	J	Diode (11ES1)	4	AB
D20-32	VHD1SS270A/-1	J	Diode (1SS270A)	13	AA
D70-76	VHD1SS270A/-1	J	Diode (1SS270A)	7	AA
IC1	RH-IZA719DRE0	J	LSI	1	AW
IC2	RH-IZA495DRE0	J	IC	1	AL
Q1	VS2SB1238// -3	J	Transistor (2SB1238)	1	AA
Q3	VSKRA101M// -3	J	Transistor (KRA101M)	1	AB
Q4	VSDTA123ES/ -3	J	Transistor (DTA123ES)	1	AA
Q20-26	VSKRC101M// -3	J	Transistor (KRC101M)	1	AB
Q27	VSKRC243M// -3	J	Transistor (KRC243M)	1	AB
Q28-30	VSKRA101M// -3	J	Transistor (KRA101M)	1	AB
Q40	VSKRA101M// -3	J	Transistor (KRA101M)	1	AB
Q60	VSKRA101M// -3	J	Transistor (KRA101M)	1	AB
Q90	VSKRA101M// -3	J	Transistor (KRA101M)	1	AB
R1	VRD-B12HF432J	J	Resistor 4.3k $\Omega$ 1/2W	1	AH
R2	VRS-B12EF152J	J	Resistor 1.5k $\Omega$ 1/4W	1	AA
R3	VRD-B13AA681J	J	Resistor 680 $\Omega$ 1.0W	1	AA
R4	VRD-B12HF511J	J	Resistor 510 $\Omega$ 1/2W	1	AB
R7-8	VRD-B12EF472J	J	Resistor 4.7k $\Omega$ 1/4W	2	AA
R30	VRD-B12EF153J	J	Resistor 15k $\Omega$ 1/4W	1	AA
R31	VRD-B12EF472J	J	Resistor 4.7k $\Omega$ 1/4W	1	AA
R40	VRD-B12EF332J	J	Resistor 3.3k $\Omega$ 1/4W	1	AA
R50	VRS-B12EF153J	J	Resistor 15k $\Omega$ 1/4W	1	AA
R51	VRD-B12EF472J	J	Resistor 4.7k $\Omega$ 1/4W	1	AA
R62	VRN-B12EK363F	J	Resistor 36k $\Omega$ 1/4W	1	AA
R63	VRN-B12EK221F	J	Resistor 220 $\Omega$ 1/4W	1	AB

REF NO.	PART NO.	§	DESCRIPTION	Q'TY	CODE
<b>CONTROL PANEL PARTS</b>					
R64	VRN-B12EK362F	J	Resistor 3.6kΩ 1/4W	1	AA
R70-74	VRD-B12EF332J	J	Resistor 3.3kΩ 1/4W	5	AA
R75	VRD-B12EF104J	J	Resistor 100kΩ 1/4W	1	AA
R76-82	VRD-B12EF332J	J	Resistor 3.3kΩ 1/4W	7	AA
R90-93	VRD-B12EF104J	J	Resistor 100kΩ 1/4W	4	AA
R100	VRS-B13AA331J	J	Resistor 330Ω 1W	1	AA
RY1-3	RRLY-A113WRE0	M	Relay (DU241-1P(M))	3	AH
RY4-9	RRLY-A080DRE0	J	Relay (OJE-SS-124LM)	6	AG
RY10	RRLY-112MRE0	M	Relay (VE-24HS5-K)	1	AM
SP40	RALM-A014DRE0	J	Buzzer (PKM22EPT)	1	AG
T1	RTRNPB004MRE0	M	Transformer	1	AN
VRS1	RH-VZA032DRE0	J	Varistor (104G471K)	1	AE
ZD1	VHEHZ6A3///-1	J	Zener diode (HZ6A-3)	1	AC
ZD2	VHEHZ161///-1	J	Zener diode (HZ16-1)	1	AA
ZD3	VHEHZ5C2///-1	J	Zener diode (HZ5C-2)	1	AA
ZD4	VHEHZ4A2///-1	J	Zener diode (HZ4A-2)	1	AA
3-2	FPNLCB153MRK0	M	Control panel with key unit R-1850A	1	BB
3-2	FPNLCB154MRK0	M	Control panel with key unit R-1851A	1	BB
3-2	FPNLCB170MRK0	M	Control panel with key unit R-1852A	1	BB
3-2-1	FUNTKB108MRE0	M	Key unit R-1850A	1	AX
3-2-1	FUNTKB109MRE0	M	Key unit R-1851A	1	AX
3-2-1	FUNTKB125MRE0	M	Key unit R-1852A	1	AX
3-2-2	GMADIB023MRF0	M	Display window	1	AD
3-2-3	MSPRTA050WRE0	M	Open button spring	1	AA
3-2-4	JBTN-B053MRF0	M	Open button R-1850A	1	AD
3-2-4	JBTN-B054MRF0	M	Open button R-1851A	1	AD
3-2-4	JBTN-B066MRF0	M	Open button R-1852A	1	AD
3-2-5	JBTN-B067MRF0	M	Select button R-1850A	1	AC
3-2-5	JBTN-B056MRF0	M	Select button R-1851A	1	AC
3-2-5	JBTN-B055MRF0	M	Select button R-1852A	1	AC
3-2-6	LANGQB036MRP0	M	Key fixing	1	AA
3-3	XEPSD30P10XS0	M	Screw; 3mm x 10mm	5	AA

<b>OVEN PARTS</b>					
4- 1	FFTA-B003MRK0	M	Exhaust damper assembly	1	AM
4- 2	FROLPB020MRK0	M	Turntable support assembly	1	AS
4- 3	NTNT-B006MRE0	M	Turntable tray	1	AZ
4- 4	LANGKB010MRP0	M	Capacitor holder	1	BB
4- 5	FCOVPB002MRY0	M	Stirrer cover assembly	1	AM
4- 6	FFAN-B003MRK0	M	Stirrer fan assembly	1	AL
4- 7	-----	M	Oven cavity (Not a replaceble part)	1	--
4- 8	DHET-B001MRK0	M	Convection heater unit	1	BL
4- 9	NCPL-B007MRF0	M	Coupling	1	AE
4-10	NFANMB003MRP0	M	Convection Motor fan	1	AE
4-11	LANGQB031MRP0	M	Convection Motor angle	1	AF
4-12	PPACGB013MRE0	M	Turntable motor packing	1	AC
4-13	LBNDK0054WRE0	M	Heater mounting holder	2	AD
4-14	NFANMB004MRP0	M	Convection motor fan	1	AE
4-15	PHOK-B013MRF0	M	Latch hook	1	AG

REF NO.	PART NO.	§	DESCRIPTION	Q'TY	CODE
<b>OVEN PARTS</b>					
4-16	FANGTB003MRY0	M	Unit mounting angle	1	AV
4-17	PFPF-B002MRE0	M	Heat protect L	2	AK
4-18	PPIPF002MRE0	M	Coller	1	AD
4-19	PREFHB006MRP0	M	Heater Cover L	1	AM
4-20	PDUC-B083MRP0	M	Hood intake duct L	1	AG
4-21	NFANPB005MRE0	M	Fan blade	1	AD
4-22	GBDYRB002MRP0	M	Back plate	1	AX
4-23	FDUC-B025MRK0	M	Fan duct	1	AM
4-24	LBSHC0037WRE0	M	Cord bushing	1	AB
4-25	FDUC-B022MRK0	M	Exhaust duct	1	AK
4-26	MLEVPB016MRF0	M	Open lever	1	AD
4-27	PCUSGB030MRP0	M	cushion	1	AC
4-28	MCAMPB001MRF0	M	Damper cam	1	AC
4-29	PCUSUB032MRP0	M	Damper cushion	1	AC
4-30	PFPF-B001MRE0	M	Heat protect R	1	AD
4-31	PFTA-B003MRP0	M	Damper plate	1	AD
4-32	PREFHB004MRP0	M	Thermal cover R	1	AK
4-33	LANGQB033MRP0	M	Hood lamp angle	1	AM
4-34	PREFHB005MRP0	M	Thermal cover bottom	1	AK
4-35	LSTPPB024MRF0	M	Door stopper	1	AD
4-36	PCOVPB047MRP0	M	Oven lamp cover	1	AD
4-37	PCOVPB050MRP0	M	Heat protect top sheat	1	AK
4-38	PCUSGB027MRP0	M	cushion	1	AA
4-39	PDUC-B056MRF0	M	Hood exhaust duct	1	AY
4-40	PDUC-B057MRF0	M	Top duct	1	AN
4-41	PDUC-B058MRF0	M	Magnetron duct	1	AD
4-42	PDUC-B060MRP0	M	Hood intake duct R	1	AH
4-43	PFILWA035WRE0	M	Oven light screen	1	AF
4-44	PFPF-B003MRE0	M	Heat protect top	1	AE
4-45	PCUSUB018MRP0	M	Exhaust cushion A	1	AA
4-46	PCUSUB019MRP0	M	Exhaust cushion B	1	AA
4-47	PCUSUB020MRP0	M	cushion	1	AA
4-48	PCUSUB024MRP0	M	cushion	1	AA
4-49	PCUSUB033MRP0	M	cushion	1	AA
4-50	PCUSGB035MRP0	M	cushion	2	AA
4-51	PCUSUB047MRP0	M	cushion	1	AA
4-52	PCUSUB046MRP0	M	cushion	2	AA

<b>DOOR PARTS</b>						
Δ	5- 0	CDORFB166MRK0	M	Door assembly R-1850A	1	BL
Δ	5- 0	CDORFB167MRK0	M	Door assembly R-1851A	1	BN
Δ	5- 0	CDORFB190MRK0	M	Door assembly R-1852A	1	BN
Δ	5- 1	FDORFB053MRT0	M	Door panel	1	BB
Δ	5- 2	GWAKPB058MRF0	M	Door frame R-1850A	1	AX
Δ	5- 2	GWAKPB076MRF0	M	Door frame R-1851A	1	AX
	5- 2	GWAKPB058MRF0	M	Door frame R-1852A	1	AX
	5- 3	PGLSPB008MRR0	M	Door glass front R-1850A	1	BD
	5- 3	PGLSPB010MRR0	M	Door glass front R-1851A	1	BD
	5- 3	PGLSPB011MRR0	M	Door glass front R-1852A	1	BD
Δ	5- 4	GCOVHB031MRF0	M	Choke cover	1	AM
Δ	5- 5	LSTPPB025MRF0	M	Latch head	1	AE
	5- 6	LSTPPB028MRF0	M	Glass stopper	1	AD
	5- 7	MSPRTA046WRE0	M	Latch spring	1	AB
	5- 8	XCTSD40P08000	M	Screw	6	AA

REF NO.	PART NO.	§	DESCRIPTION	Q'TY	CODE
<b>MISCELLANEOUS</b>					
6- 1	CFZK-B131MRK0	M	Installation material assembly	1	AM
6-1-1	LBSHC0040MRE0	M	Gromment	1	AC
6-1-2	LX-BZ0195WRE0	M	Toggle screw	4	AC
6-1-3	LX-MZB001MRE0	M	Cord holder	1	AC
6-1-4	XBRSD50P60000	M	Screw; 5mm x 60mm	2	AC
6-1-5	XOTSD40P12000	M	Screw; 4mm x 12mm	1	AA
6-1-6	XTSSD50P35000	M	Screw; 5mm x 35mm	6	AA
6-1-7	XWHSD50-16300	M	Washer	2	AA
6- 2	TINSEB141MRR0	M	Installation instructions	1	AD
6- 3	TINSEB199MRR0	M	Operation manual	1	AE
6- 4	TINSKB018MRR0	M	Top template	1	AD
6- 5	TINSKB019MRR0	M	Wall template	1	AD
6- 6	QW-QZB011MRE0	M	High voltage wire A	1	AD
6- 7	TCADCB012MRR0	M	Cook book	1	AP
6- 8	FW-VZB166MRE0	M	Main wire harness A	1	AY
6- 9	UAMI-B007MRM0	M	High rack	1	AQ
6-10	UAMI-B008MRM0	M	Low rack	1	AP
6-11	FW-VZB077MRE0	M	Main harness C	1	AH
6-12	TCAUAA025WRR0	M	Caution label	1	AA
6-13	TCAUAB005MRR0	M	DHHS caution label	1	AB
6-14	TCAUAB015MRR0	M	Monitor caution label	1	AA
<b>FASTENERS</b>					
7- 1	XCPSD40P08000	M	Screw; 4mm x 8mm	2	AA
7- 2	XOTSF40P10000	M	Screw; 4mm x 10mm R-1850A	3	AC
7- 2	XOTSE40P10000	M	Screw; 4mm x 10mm R-1851A, R-1852A	3	AC
7- 3	XCBSD30P08000	M	Screw; 3mm x 8mm	2	AA
7- 4	XBTSD40P08RV0	M	Screw; 3mm x 6mm	2	AA
7- 5	XCBSD30P08000	M	Screw; 3mm x 8mm	2	AA
7- 6	XBTWW40P06000	M	Screw; 4mm x 8mm	2	AA
7- 7	XOTSD40P12000	M	Screw; 4mm x 12mm	26	AA
7- 8	XOTSF40P12000	M	Screw; 4mm x 10mm R-1850A	3	AA
7- 8	XOTSE40P12000	M	Screw; 4mm x 10mm R-1851A, R-1852A	3	AA
7- 9	LX-BZ0208WRE0	M	Screw; 4mm x 8mm	2	AA
7-10	LX-BZB011MRE0	M	Unit mounting screw	2	AH
7-11	LX-CZA038WRE0	M	Special screw	4	AA
7-12	XCBWW30P08000	M	Screw; 3mm x 6mm	8	AA
7-13	LX-CZ0052WRE0	M	Special screw	2	AA
7-14	XCTWW40P08RV0	M	Screw; 4mm x 8mm	2	AC
7-15	XRES40-06000	M	E-ring	1	AA
7-16	XOTSD40P12000	M	Screw; 4mm x 12mm	2	AC
7-17	XCTWW40P08000	M	Screw; 4mm x 8mm	3	AA
7-18	XOTWW40P10000	M	Screw; 4mm x 8mm	8	AA
7-19	XWSUW40-10000	M	Spring Washer	1	AA
7-20	LX-BZ0081YBE0	M	Screw; 4mm x 8mm	9	AA
7-21	XWHSD50-20120	M	Washer; 5mm x 2mm	1	AA
7-22	XWHUW40-08100	M	Washer; 4mm x 0.8mm	2	AA
7-23	XWHUW40-08120	M	Washer; 5mm x 0.8mm	1	AA
7-24	XOTSD40P08000	M	Screw; 4mm x 8mm	8	AA

# Cavity Assembly

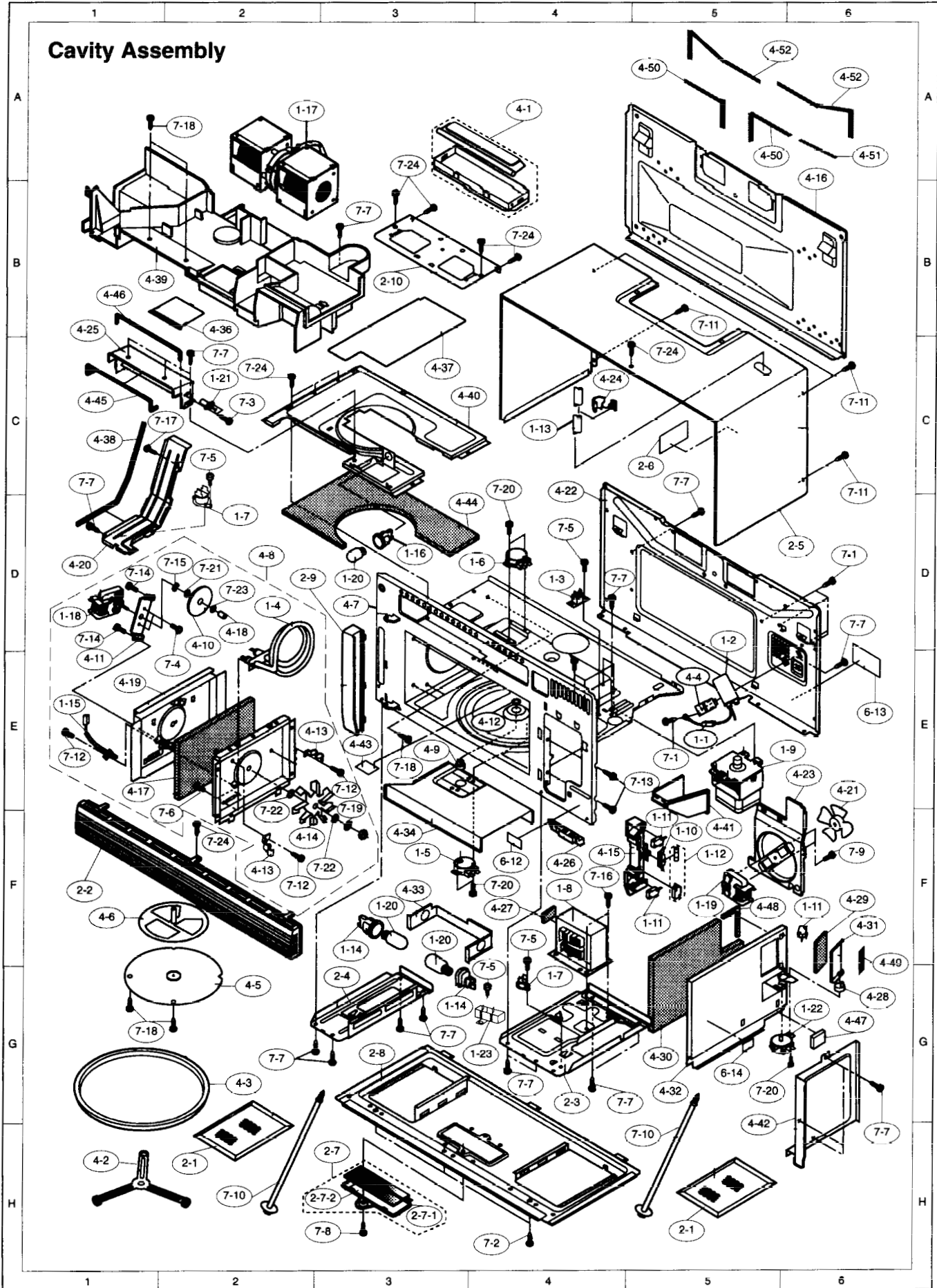

# Control Panel Assembly

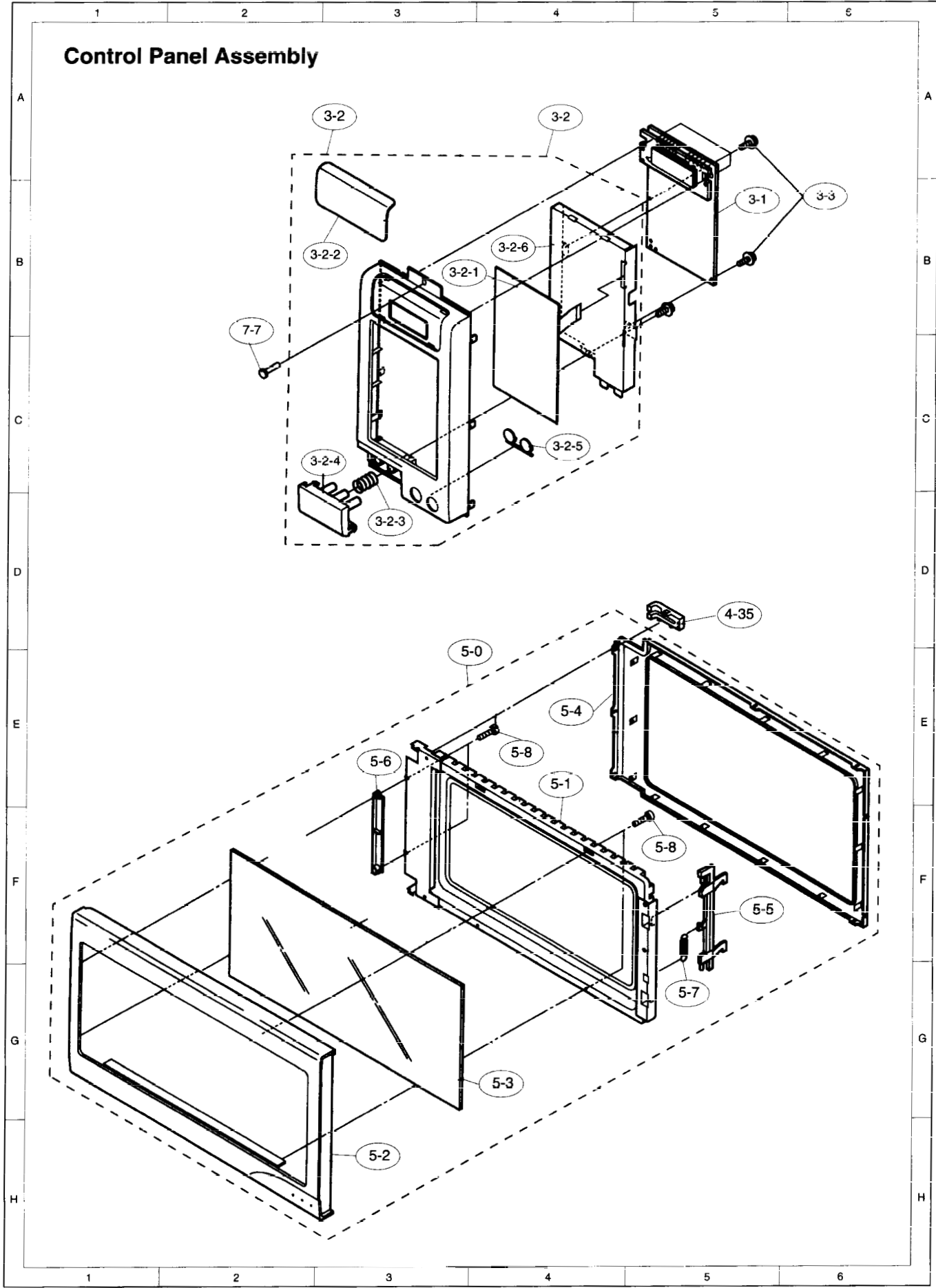

### Miscellaneous

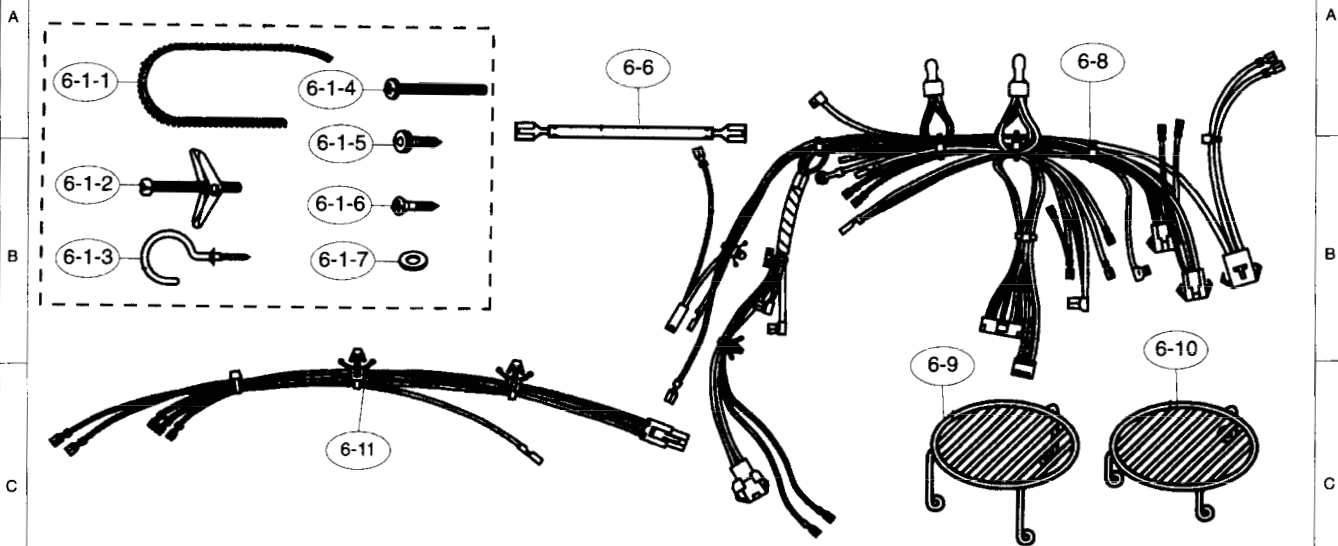

### Packing and Accessories

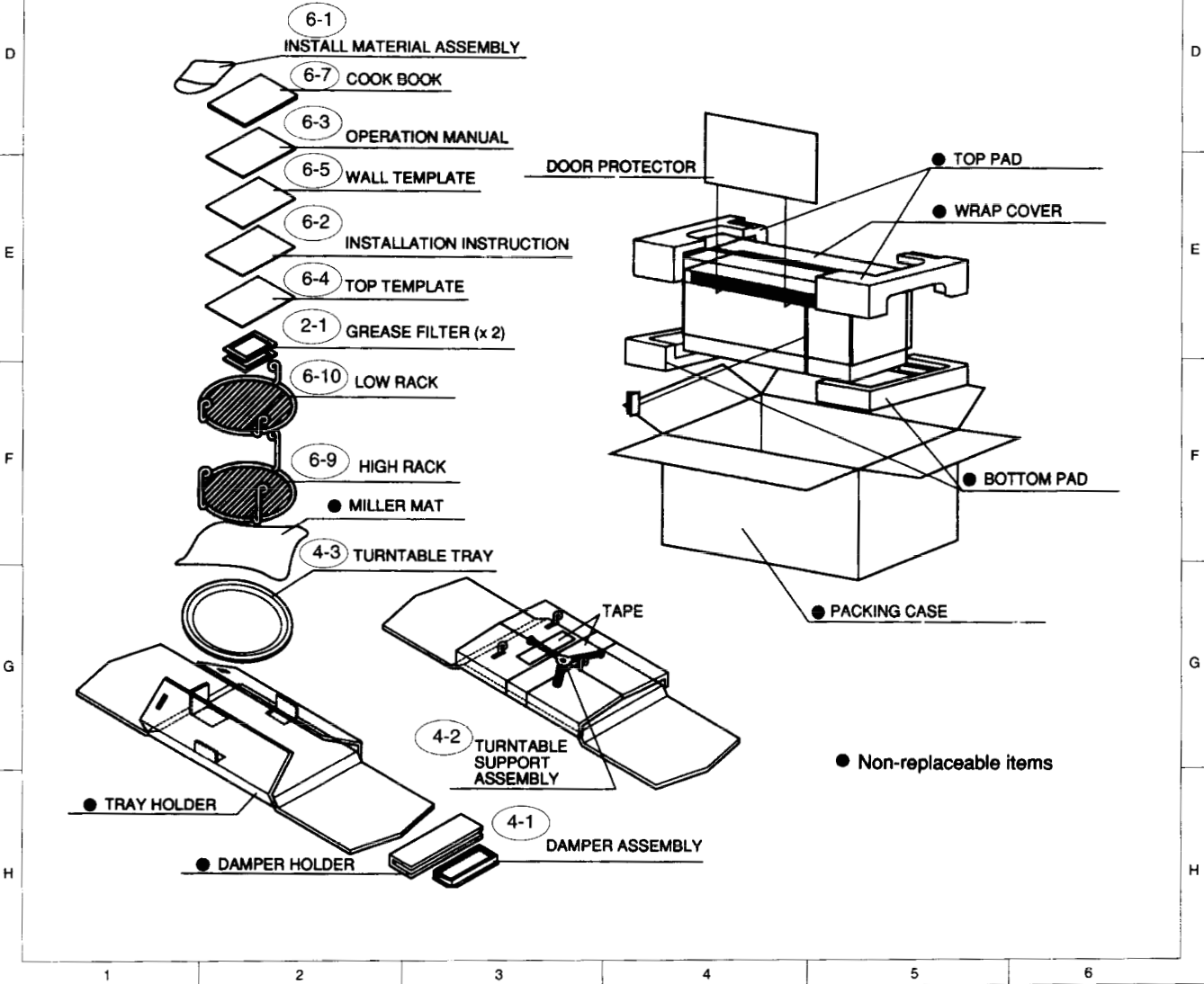

R-1850A  
R-1851A  
R-1852A

**SHARP®**