

This Owner's Manual is provided and hosted by [Appliance Factory Parts](#).



COLDSPOT 625660 Owner's Manual

[Shop genuine replacement parts for COLDSPOT
625660](#)



[Find Your COLDSPOT Refrigerator Parts - Select From 68 Models](#)

----- Manual continues below -----

Cuisinart™

INSTRUCTION
BOOKLET



Private Reserve™ Wine Cellar

CWC-600

For your safety and continued enjoyment of this product, always read the instruction book carefully before using.

IMPORTANT SAFEGUARDS

When using an electrical appliance, basic precautions should always be followed to reduce the risk of fire, electric shock, and personal injury, including the following:

1. Use this appliance only as described in this manual. Other uses not recommended may cause fire, electric shock or personal injury.
2. This product is intended for household use only.
3. To protect against electric shock, do not immerse unit, plug or cord in water or spray with liquids.
4. Close supervision is necessary when any appliance is used by or near children.
5. Unplug from the outlet when not in use when moving from one location to another, and before cleaning.
6. To disconnect the appliance, grip the plug and pull it from the wall outlet. Never pull by the cord.
7. Do not operate the appliance in the presence of explosive and/or flammable fumes.
8. Do not place the appliance or any of its parts near an open flame, cooking or other heating appliance.
9. Do not operate the appliance with a damaged cord or plug, if the product malfunctions, or if it is dropped or damaged in any manner.
10. The use of attachments not recommended by the manufacturer may be hazardous.
11. Place the unit on a dry level surface.
12. Do not operate if the housing is removed or damaged.
13. A loose fit between the AC outlet (receptacle) and plug may cause overheating and a distortion of the plug. Contact a qualified electrician to replace loose or worn outlet.
14. This appliance is designed to be freestanding only, and should not be recessed or built in (fully recessed.)
15. Locate the unit away from direct sunlight and sources of heat (stove, heater, radiator, etc.). Direct sunlight will affect/alter the outside color of the appliance.

WARNING: To reduce the risk of fire, electric shock or personal injury, unplug or disconnect the appliance from the power supply before servicing.

SAVE THESE INSTRUCTIONS

FOR HOUSEHOLD USE ONLY

SPECIAL CORD SET INSTRUCTIONS

NOTICE

For your protection, this unit is equipped with a 3-conductor cord set that has a molded 3-prong grounding-type plug, and should be used in combination with a properly connected grounding-type outlet as shown in figure A. If a grounding-type outlet is not available, an adapter, shown in Figure B, may be obtained so that a 2-slot wall outlet can be used with a 3-prong plug. As shown in Figure C, the adapter must be grounded by attaching its grounding lug under the screw of the outlet cover plate.

NOTE: Do not remove the grounding prong.

CAUTION: Before using an adapter, it must be determined that the outlet cover plate screw is properly grounded. If in doubt, consult a licensed electrician. Never use an adapter unless you are sure it is properly grounded.

Note: Use of an adapter is not permitted in Canada.

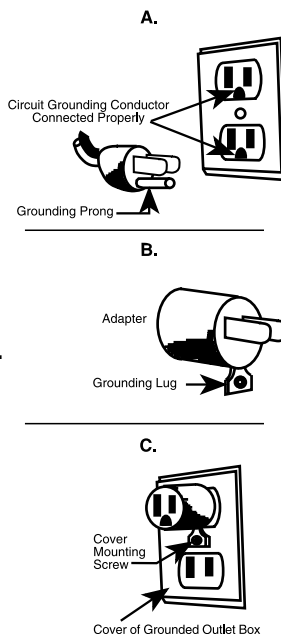

CONTENTS

Important Safeguards.	2
Special Cord Set Instructions.	2
Introduction	3
Parts.	3
Using Your Wine Cellar	3
Operating Instructions	4
Temperature Control	4
Mode Selection Procedure	5
Serving Wines/Temperature Chart	6
Storing Wines/Temperature Chart	7
Interior Light Control	8
Cleaning and Care	8
Wine Tips and Hints.	8
Wine and Food Pairing Guide.	9
Troubleshooting.	10
Warranty.	11

USING YOUR WINE CELLAR

Remove all packaging and any promotional labels or stickers from your wine cellar. Be sure that all parts (listed above) of your new wine cellar have been included before discarding any packaging materials. You may want to keep the box and packing materials for use at a later date.

Before using your Cuisinart™ Private Reserve™ Wine Cellar for the first time, remove all protective paper and wrapping. Wipe housing and internal chamber with a damp cloth to remove any dust from the warehouse or shipping.

INTRODUCTION

Different wines must be served at different temperatures to optimize flavor. Your Private Reserve™ Wine Cellar has 8 convenient presets to keep each type of wine at the temperature recommended by experts.

You'll love the way this traditionally styled countertop wine cellar looks in your kitchen. With its smooth brushed stainless steel door, tinted glass window, and soft interior lighting that you can leave on or turn off, it's an elegant way to ensure that your favorite wines and champagnes are beautifully displayed and ready to serve.

PARTS

1. Stainless steel veneered door with handle
2. Tinted double-pane window
3. LED display
4. Cabinet
5. Control panel
6. 3 removable chrome wine racks
7. Interior light control
8. Circulating fan

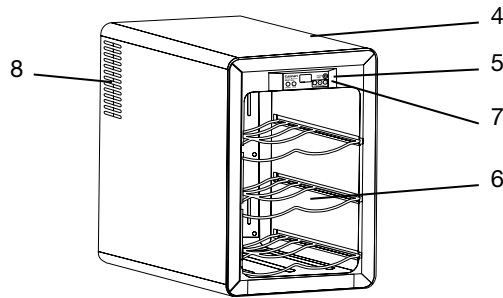
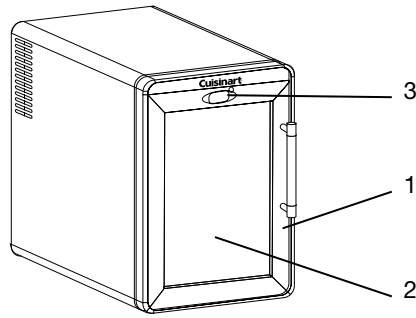

OPERATING INSTRUCTIONS TEMPERATURE CONTROL

1. Place your wine cellar on a flat surface that is strong enough to support it when fully loaded.
2. Allow 3" (76mm) of space on both sides and rear of the wine cellar to allow proper ventilation.
3. This wine cellar is designed to be freestanding only, and should not be recessed or built in (fully recessed).
4. Do not place heavy objects on top of the unit.
5. Do not locate the unit in a moist place or display in direct sunlight.
6. Do not place the unit next to a major appliance that emits large amounts of heat, such as a dishwasher, microwave, toaster oven, oven or barbecue, etc.
7. Do not plug unit into the same outlet as a refrigerator or microwave.
8. The unit's cooling system operates efficiently with an ambient temperature of less than 70°F (21°C).
9. Gently place/slide the racks in the wine cooler.
10. Determine the best setting to use: refer to the temperature guides for appropriate storing or serving presets (see pages 6 to 7).
11. Place bottles inside the cooler.
12. Plug the power cord into a standard electrical outlet.
13. This appliance has no serviceable parts. If for any reason this product does not function satisfactorily return to Cuisinart's Authorized Service Center toll-free 800-726-0190.

Important: When using the wine cellar for the first time, allow at least 24 hours for the internal temperature to adjust properly. Make sure there are at least 3 to 5 bottles in the unit.

ALWAYS REMOVE ALL BOTTLES BEFORE MOVING THE WINE CELLAR

Important note: In order to operate efficiently, thermoelectric products should be in an environment with an ambient temperature of less than 70°F (21°C).

Setting the temperature control (presets):

For your convenience, the Cuisinart™ Private Reserve™ Wine Cellar is programmed with eight presets, to accommodate any variety of wine.

To change the preset temperature in the wine cooler, simply press the Preset button until the desired preset number (1 to 8) appears. The following sections about storing and serving wines (see pages 6 to 7) will advise the optimal settings for your wine.

MODE SELECTION PROCEDURE

Default setting: Mode 1

1. Press Preset button.
2. Choose Mode Number (1-8) by pressing Preset button repeatedly. Selected Mode Number will blink for approximately 5 seconds.
3. LED display will show the corresponding preset temperature of the selected mode. It will blink until the chosen mode temperature is reached.

Adjusting the temperature (Manual Setting)

Default setting: 7°C (45°F)

1. Press Manual Set button.
2. Press (+) or (-) button to adjust the temperature.
3. Press Manual Set for confirmation.
4. Temperature on LED display will blink until it reaches the desired temperature.

Choosing Fahrenheit or Celsius

Default setting: °C

1. Press °C/°F button to select temperature unit.

Controlling interior display light

Default setting: Light is off when door is closed/light is on when door is open.

1. Press the Display Light button to keep display light on all the time.
2. Press the Display Light button to return to default setting .

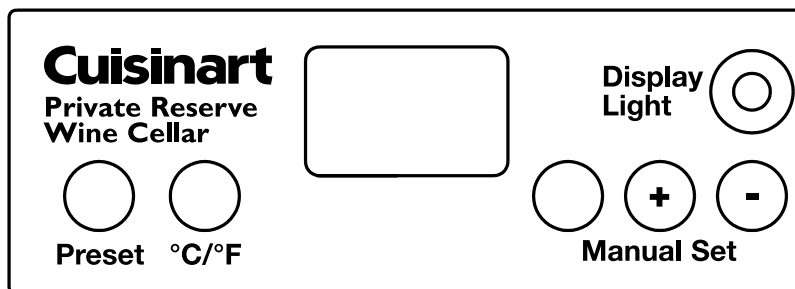

SERVING WINES

In the chart below, an asterisk (*) following a type of wine suggests the optimal setting for this wine.

If you have a variety of white wines in the cabinet, Preset #3 is recommended. A variety of red wines should be set at Preset #4.

SERVING TEMPERATURE CHART

PRESET	WINE TYPE
8	<ul style="list-style-type: none">• Light red• Rosé*
7	<ul style="list-style-type: none">• Full-bodied white* (e.g., French white Burgundies)
6	<ul style="list-style-type: none">• Light red* (e.g., Beaujolais or Valpolicella)
5	<ul style="list-style-type: none">• Medium reds* (e.g., Pinot Noir)
4	<ul style="list-style-type: none">• Bolder reds* (e.g., Bordeaux, Rhône, Barolo, Chianti, Cabernet Sauvignon)
3	<ul style="list-style-type: none">• Champagne/sparkling wine• White wine*
2	<ul style="list-style-type: none">• Champagne/sparkling wine*• Light white
1	<ul style="list-style-type: none">• Champagne/sparkling wine• Fruit/dessert wine*

STORING WINES

Storing wines at the proper temperature is important. Stored too cold, the aroma and flavor of the wine will be diminished. Stored too warm, the flavor of the wine can become too harsh, flat in flavor, or taste too strongly alcoholic.

Because it is carefully limited to a temperature range that will preserve and enhance wines, any setting of the Cuisinart™ Private Reserve™ Wine Cellar is appropriate for storing most wines.

The only exceptions are:

- Champagne is best stored at presets 1, 2 or 3
- Red wine is best stored at presets 4, 5, 6, 7, or 8

STORAGE TEMPERATURE CHART

PRESET	WINE TYPE
8	<ul style="list-style-type: none">• Red• Light red• White• Fruit/dessert wine
7	<ul style="list-style-type: none">• Red• Light red• White• Fruit/dessert wine
6	<ul style="list-style-type: none">• Red• Light red• White• Fruit/dessert wine
5	<ul style="list-style-type: none">• Red• Light red• White• Fruit/dessert wine
4	<ul style="list-style-type: none">• Red• Light red• White• Fruit/dessert wine
3	<ul style="list-style-type: none">• Light red• Champagne/sparkling wine• White• Fruit/dessert wine
2	<ul style="list-style-type: none">• Light red• Champagne/sparkling wine• White• Fruit/dessert wine
1	<ul style="list-style-type: none">• Light red• Champagne/sparkling wine• White• Fruit/dessert wine

INTERIOR LIGHT CONTROL

The interior display light option allows you to showcase your personal collection of wines. To activate this feature, press the display light switch. This switch is located on the control panel (see Parts, page 3). The interior light will remain ON permanently while in this position. When in the OFF position, the interior light will illuminate only when the door is opened.

CLEANING AND CARE

Always unplug the wine cooler before cleaning. Do not use benzene, scrubbing brushes or chemical cleaners, as these will damage the unit. Use only a mild, nonabrasive cleanser to clean the exterior of the cabinet. Clean the stainless steel door and handle by wiping with a damp cloth. Wash the inside surface with a warm water and baking soda solution. The solution should be about 2 tablespoons of baking soda to a quart of water. Wash the racks with a mild detergent solution. Always dry all the parts with a clean dry cloth before plugging the wine cooler back into the receptacle.

WINE TIPS AND HINTS

When choosing wine, take advantage of the knowledge of the personnel in the wine store as well as reviews of wines from wine publications. The price of a wine is not necessarily indicative of relative quality. Very good wines can be purchased at comfortable-for-the-wallet prices. When you find a comfortably priced wine, purchase in quantity to have on hand as your "house wine." Keep it chilled in your Cuisinart™ Private Reserve™ Wine Cellar and be ready for any occasion.

Pairing wine with food has really become a matter of personal taste – the rules are no longer hard and fast that white wine is paired only with fish or light meats and red wine is paired only with red meats. A Pinot Noir can complement a grilled fish just as well as it complements a grilled fillet of beef.

What needs to be kept in mind is the personality of the wine itself, the preparation of the foods, and the tastes of those who will be enjoying them. You may want to open a bottle each of red and white and allow your guests to choose.

The wine should please the diner, and never overpower or fight with the food with which it is served. Likewise, the food should not overpower or fight with the wine.

Wine is a part of healthy living – the USDA's guidelines are based upon the "Mediterranean diet." They include wine in moderation – for women this is one glass per day and two glasses per day for men. A glass size is 4 ounces. The difference in gender amount is based upon body size.

As for cooking with wine – never cook with a wine that you would not drink!

WINE AND FOOD PAIRING GUIDE

CHEESE	
Hard	All reds
Cheddar	Cabernet Sauvignon, Shiraz, Burgundy, Merlot
Soft	Sparkling, Riesling, Gewürztraminer, Pinot Noir, Beaujolais Nouveau, light reds
Goat cheeses	Sauvignon Blanc, Sancerre, Riesling, Dry Muscat
Blue cheeses	Zinfandel, Riesling, Shiraz, Rhône reds
MEATS	
Beef, Venison	Shiraz, Cabernet Sauvignon, red Bordeaux, red Burgundy, Merlot, full Italian reds, Zinfandel
Ham	Sparkling wine, Gewürztraminer
Lamb	All dry reds
Pork	Shiraz, Cabernet Sauvignon, Burgundy, Merlot, rosé, Rioja
Veal	Shiraz, Cabernet Sauvignon, Merlot, Pinot Noir
Chicken	White Burgundy, Chardonnay, Pinot Noir, Merlot, Chianti, Rioja, rosé (light reds and full whites)
Game Birds	Shiraz, Cabernet Sauvignon, Merlot, red Burgundy
Turkey	Riesling, Chardonnay, Pinot Noir, Beaujolais
FISH	
Shellfish	Chablis, white Burgundy, Sauvignon Blanc, Chenin Blanc, Chardonnay
Salmon/tuna/trout	Sauvignon Blanc, Chardonnay, Chenin Blanc, Pinot Noir, Beaujolais Nouveau, light reds
Light Fish	Light Chardonnay, white Bordeaux, Sauvignon Blanc (Sancerre, Pouilly Fumé), dry rosé
OTHER FOODS	
Vegetarian	Most dry or lighter whites, rosé
Pasta	Dry whites, Pinot Noir, Shiraz, Cabernet Sauvignon, Burgundy, Merlot, Barbera, Chianti, Montepulciano
Spicy Asian/Chinese	Riesling, Gewürztraminer, Sauvignon Blanc, Chablis, Chardonnay, white Burgundy, Chenin Blanc, Champagne, Merlot
Japanese	All dry whites, sparkling wines
DESSERTS	
Fruit	Riesling, Chardonnay, white Burgundy
Fruit tart, ice cream, nuts	Riesling, Muscat Blanc, Chenin Blanc, ice wine
Chocolate	Fruity reds, Cabernet, Shiraz, Merlot, sparkling wine, ice wine

TROUBLESHOOTING

You can easily solve many common problems by trying the suggestions below.

SYMPTOM	POSSIBLE CAUSE
Vibrations	<ul style="list-style-type: none"> • Check to make sure the wine cooler is on a level surface.
The door will not close properly	<ul style="list-style-type: none"> • The wine cooler is not on a level surface. • The racks are out of position. • A bottle is too long.
Fan is always running.	<ul style="list-style-type: none"> • This is simply a function of the cooling system. The lower the setting, the more the fan will run. If the room is warmer than 70°F (21°C), it will run more.
Unit has no power.	<ul style="list-style-type: none"> • Check the wall outlet for power. Make sure the outlet is not controlled by a wall switch.
The inside temperature does not seem correct.	<ul style="list-style-type: none"> • Make sure the cooling vents on the right and left sides of the cooler are not obstructed. Have at least 3" (76 mm) of space on both sides and rear of unit. • The room may be too hot. Example: if the ambient temperature is 80°F (27°C) or higher, the unit can have difficulty chilling adequately on the white wine setting. • When using the unit for the first time, it can take the unit up to 24 hours to reach the desired temperature.
The unit does not operate.	<ul style="list-style-type: none"> • It may not be plugged into the wall socket. • Make sure the wall socket is functional by testing another electrical appliance in the power socket.
The unit will not cool. Power is on.	<ul style="list-style-type: none"> • Make sure there are at least 3 to 5 bottles in the unit. • Allow at least 24 hours for the internal temperature to adjust properly. • If the room temperature is above 75°F (24°C), the unit will not get below 51°F (11°C). Humidity does not affect the cooling ability of the unit. To achieve accurate temperature control, the unit should not be used or operated in any of the following locations: <ul style="list-style-type: none"> – in a sunny place – in a room with poor air circulation such as a garage – near another heat-producing appliance (dishwasher, oven, refrigerator). – with an outlet shared with a refrigerator, as the refrigerator will drain power from the wine cellar. – in a cabinet or closet. And remember to have at least 3" (76 mm) of space on all sides of unit.
General Statements	<ul style="list-style-type: none"> • The unit can be manually set using the + and – symbols. The minimum setting is 45°F (7°C) and maximum is 68°F (20°C). • The unit does not use any CFCs. There is no compressor inside this unit. • The unit uses about as much energy as a 100-watt light bulb.

WARRANTY

Cuisinart™ Wine Cellar LIMITED THREE-YEAR WARRANTY

This warranty supersedes all previous warranties on the Cuisinart™ Private Reserve™ Wine Cellar. This warranty is available to consumers only. You are a consumer if you own a Cuisinart™ Private Reserve™ Wine Cellar that was purchased at retail for personal, family or household use. Except as otherwise required under applicable state law, this warranty is not available to retailers or other commercial purchasers or owners.

We warrant that your Cuisinart™ Private Reserve™ Wine Cellar will be free of defects in material or workmanship under normal home use for three years from the date of original purchase.

We suggest that you complete and return the enclosed warranty registration card promptly to facilitate verification of the date of original purchase. However, return of the warranty registration is not a condition of these warranties.

If your wine cellar should prove to be defective within the warranty period, we will repair it (or, if we think it necessary, replace it) without charge to you. To obtain warranty service, please call our Consumer Service Center toll-free at 800-726-0190 or write to:

Cuisinart
150 Milford Road
East Windsor, NJ 08520

To facilitate the speed and accuracy of your return, please also enclose \$10.00 for shipping and handling of the product (California residents need only supply proof of purchase and should call 1-800-726-0190 for shipping instructions). Please also be sure to include a return address, description of the product defect, product serial number, and any other information pertinent to the product's return. Please pay by check or money order.

NOTE: For added protection and secure handling of any Cuisinart® product that is being returned, we recommend you use a traceable, insured delivery service. Cuisinart cannot be held responsible for intransit damage or for packages that are not delivered to us. Lost and/or damaged products are not covered under warranty.

Your Cuisinart™ wine cellar has been manufactured to strict specifications and has

been designed for use with the Cuisinart™ wine cellar authorized accessories and replacement parts for your model. These warranties expressly exclude any defects or damages caused by accessories, replacement parts or repair service other than those that have been authorized by Cuisinart.

These warranties exclude all incidental or consequential damages. Some states do not allow the exclusion of or limitation of incidental or consequential damages, so the foregoing limitation or exclusion may not apply to you.

CALIFORNIA RESIDENTS ONLY

California law provides that for In-Warranty Service, California residents have the option of returning a nonconforming product (A) to the store where it was purchased or (B) to another retail store which sells Cuisinart products of the same type. The retail store shall then, according to its preference, either repair the product, refer the consumer to an independent repair facility, replace the product, or refund the purchase price less the amount directly attributable to the consumer's prior usage of the product. If the above two options do not result in the appropriate relief to the consumer, the consumer may then take the product to an independent repair facility if service or repair can be economically accomplished.

Cuisinart and not the consumer will be responsible for the reasonable cost of such service, repair, replacement, or refund for nonconforming products under warranty.

California residents may also, according to their preference, return nonconforming products directly to Cuisinart for repair or, if necessary, replacement by calling our Consumer Service Center toll-free at 800-726-0190. Cuisinart will be responsible for the cost of the repair, replacement, and shipping and handling for such nonconforming products under warranty.

BEFORE RETURNING YOUR CUISINART PRODUCT

Important: If the nonconforming product is to be serviced by someone other than Cuisinart's Authorized Service Center, please remind the service to call our Consumer Service Center to ensure that the problem is properly diagnosed, the product serviced with the correct parts, and to ensure that the product is still under warranty.

Cuisinart™

SAVOR THE GOOD LIFE™



Cuisinart offers an extensive assortment of top quality products to make life in the kitchen easier than ever. Try some of our other countertop appliances and cookware, and Savor the Good Life™.

www.cuisinart.com

©2006 Cuisinart
Cuisinart® is a registered trademark
of Cuisinart
150 Milford Road
East Windsor, NJ 08520
Printed in China
06CU26124

U IB-6706A

Version no.: CWC600 IB-6706A
Size: 152mm(W) x 203mm (H) Total Pages: 12 pages
Material: Cover : 157gsm Matt Artpaper Inside : 120gsm Gloss Artpaper
Coating: Gloss Varnishing on cover
Color: Cover:4C + 1C (Black) Inside:1C + 1C (Black)
Date: 05-20-2006(amend P.4)
P. O. No. 0605000 (05-00-2006_OP)
Coordinater: Astor You

 新成分色製版公司
Classic Graphic Arts Company
Tel: 2357 0071 Fax: 2357 0318