

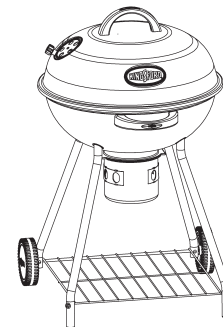

Distributed By:  
 Masterbuilt Manufacturing, Inc.  
 A Georgia Company  
 450 Brown Avenue  
 Columbus, Georgia 31906  
 Customer Service 1-800-489-1581







**ASSEMBLY, CARE & USE MANUAL  
 WARNING & SAFETY INFORMATION  
 MODEL 10040206 22.5" KETTLE CHARCOAL GRILL  
 THIS PRODUCT IS FOR OUTDOOR USE ONLY**



Manual Code: 988060005 rev 060124

Tools required for assembly: Adjustable Wrench, Phillips Head Screwdriver.

 <b>CARBON MONOXIDE HAZARD</b> 	 <b>WARNING</b> 
<p>Burning charcoal gives off carbon monoxide, which has no odor and can cause death.</p> <p><b>DO NOT</b> burn charcoal inside homes, vehicles, tents, garages or any enclosed areas.</p> <p>Use only outdoors where it is well ventilated.</p>	<p>This manual contains important information necessary for the proper and safe use of this grill.</p> <p>Read and follow all warnings and instructions before using grill and during use.</p> <p>Keep this manual for future reference.</p>
<p>Failure to follow these warnings and instructions properly could result in fire or explosion, which could cause property damage, personal injury, or death.</p>	

<b>GENERAL WARNING AND SAFETY INFORMATION</b>
<ul style="list-style-type: none"> <li>• Keep a fire extinguisher accessible at all times while operating grill.</li> <li>• Never leave grill unattended while in use.</li> <li>• Never use inside an enclosed area such as a patio, garage, building or tent.</li> <li>• Never use inside a vehicle, not even a recreational vehicle such as a motor home, camper or truck bed.</li> <li>• Never operate this grill under any overhead construction such as roof coverings, carports, awnings or overhangs.</li> <li>• Maintain a minimum distance of 10 feet from all structures.</li> <li>• Keep area clear of all combustible materials such as wood, dry plants, grass, brush, paper or canvas.</li> <li>• Never operate this grill within 25 feet of flammable liquids.</li> <li>• Never operate this grill within 10 feet of a gas cylinder.</li> <li>• Never use this grill as a heater (READ CARBON MONOXIDE HAZARD).</li> <li>• Use this grill only on a stable, level surface to prevent tipping.</li> <li>• Use on non-combustible surfaces such as dirt, concrete, brick or rock.</li> <li>• Keep children and pets away from grill at all times. Do not allow children to use grill.</li> <li>• Only use charcoal lighting fluid. Never use gasoline, alcohol or other highly volatile fluids to ignite charcoal. These fluids can explode causing injury or death.</li> <li>• Grill is HOT while in use and will remain HOT for a period of time afterwards. Do not touch any part of the grill without wearing protective gloves.</li> <li>• Never move grill when in use. Allow grill to cool completely before moving or storing.</li> <li>• Never leave HOT coals or ashes unattended.</li> <li>• Do not store grill with HOT ashes or charcoal inside grill. Store only when fire is completely out and all surfaces are cold.</li> <li>• Dispose of cold ashes by placing them in aluminum foil, soaking with water and discarding in a non-combustible container.</li> <li>• Accessory attachments not supplied by Masterbuilt Manufacturing, Inc. are not recommended.</li> <li>• Never use this product for anything other than its intended purpose. This grill is not for commercial use.</li> <li>• Always use this grill in accordance with all applicable local, state and federal fire codes.</li> </ul>
<b>WARNING</b>
<b>Combustion by-product produced when using this product contains chemicals known to the State of California to cause birth defects, other reproductive harm, or cancer.</b>

**WARRANTY INFORMATION**

Masterbuilt warrants its products to be free from defects in material and workmanship under proper assembly, normal use and recommended care for 90 days from the date of original retail purchase.

Masterbuilt warranty does not cover paint finish as it may burn off during normal use. Masterbuilt warranty does not cover rust of the unit.

Masterbuilt requires reasonable proof of purchase for warranty claims and suggests that you keep your receipt. Upon the expiration of such warranty, all such liability shall terminate.

Within the stated warranty period, Masterbuilt, at its discretion, shall repair or replace defective components free of charge with owner being responsible for shipping. Should Masterbuilt require return of component(s) in question for inspection Masterbuilt will be responsible for shipping charges to return requested item.

This warranty excludes property damage sustained due to misuse, abuse, accident, damage arising out of transportation, or damage incurred by commercial use of this product.

*This expressed warranty is the sole warranty given by Masterbuilt and is in lieu of all other warranties, expressed or implied including implied warranty, merchantability, or fitness for a particular purpose.*

Neither Masterbuilt nor the retail establishment selling this product, has authority to make any warranties or to promise remedies in addition to or inconsistent with those stated above.

Masterbuilt's maximum liability, in any event, shall not exceed the purchase price of the product paid by the original consumer/ purchaser. Some states do not allow the exclusion or limitation of incidental or consequential damages. In such a case, the above limitations or exclusions may not be applicable.

**California residents only:** Notwithstanding this limitation of warranty, the following specific restrictions apply; if service, repair, or replacement of the product is not commercially practical, the retailer selling the product or Masterbuilt will refund the purchase price paid for the product, less the amount directly attributable to use by the original buyer prior to the discovery of the nonconformity. Owner may take the product to the retail establishment selling this product in order to obtain performance under warranty.

This expressed warranty gives you specific legal rights, and you may also have other rights which vary from state to state.

**COMPLETE & RETURN TO**

**ATTN: WARRANTY REGISTRATION**

**Masterbuilt Manufacturing, Inc.**

450 Brown Avenue, Columbus, GA 31906

Name: \_\_\_\_\_

Address: \_\_\_\_\_

City: \_\_\_\_\_

State/Province: \_\_\_\_\_ Postal Code: \_\_\_\_\_

Phone Number: \_\_\_\_\_ E-Mail Address: \_\_\_\_\_

Model Number: \_\_\_\_\_ Serial Number: \_\_\_\_\_

Purchase Date: \_\_\_\_\_ Place of Purchase: \_\_\_\_\_



**KINGSFORD® BARBECUE SECRETS**

**SLOW COOKING** is perfect for foods that require longer cooking times, such as chicken and ribs. With this method, grilling is at a consistent temperature without direct exposure to the flame. Your food gets thoroughly cooked but remains juicy inside.

**START** by stacking briquets in a pyramid. Add lighter fluid following directions on fluid container. Light charcoal. **LEAVE GRILL UNCOVERED.** Once briquets ash over, spread all coals around the outer edge of charcoal grate, leaving none in the center.

**PLACE AN ALUMINUM DRIP PAN** in empty center space. Pour 1 inch of water into drip pan. This will add moisture to food and prevent it from drying out. Place cooking grates on grill. Position food in center.

**COVER THE GRILL** to allow food to cook evenly on both sides so less turning is necessary.

**ENJOY THE DELICIOUS, JUICY RESULTS OF SLOW COOKING.**

The **KINGSFORD** trademark and logo are registered trademarks of The Kingsford Products Company, LLC. and are used under license by Masterbuilt Manufacturing, Inc. All rights reserved.

**PARTS LIST**

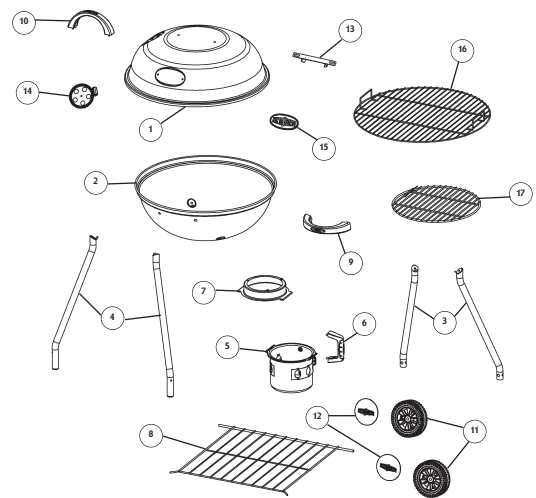

ITEM NO.	QUANTITY	DESCRIPTION	ITEM NO.	QUANTITY	DESCRIPTION
1	1	Kettle Lid	10	1	Kettle Lid Handle
2	1	Kettle Base	11	2	Wheels
3	2	Short Legs	12	2	Hub Caps
4	2	Long Legs	13	1	Lid Hook
5	1	Ash Can w/Air Dampers	14	1	Lid Air Damper
6	1	Ash Can Handle	15	1	Logo Plate (preassembled)
7	1	Ash Can Spacer Ring	16	1	Cooking Grate
8	1	Storage Shelf	17	1	Charcoal Grate
9	1	Kettle Base Handle			

## HARDWARE LIST

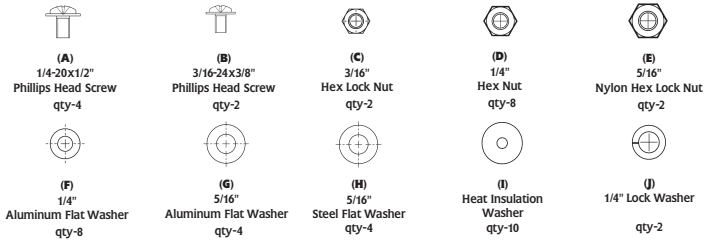

## REPLACEMENT PARTS LIST

ITEM NO.	DESCRIPTION
990060081	Short Leg Kit
990060082	Long Leg Kit
990060083	Kettle Lid Kit
990060084	Kettle Base Kit
990060085	Ash Can Handle Kit
990060130	Ash Can Spacer Ring Kit
906060054	Ash Can w/pre-mounted Dampers
990060086	Storage Shelf Kit
990060087	Wheel Kit
990060088	Lid Handle Kit
990060089	Base Handle Kit
990060095	Lid Air Damper Kit
990060092	Lid Hook Kit
990060093	Logo Plate Kit
906060049	Hub Cap
906060056	Cooking Grate
906060050	Charcoal Grate
988060005	Instruction Manual
998060002	Hardware Kit

### STOP!

DO NOT RETURN TO RETAILER  
For Assembly Assistance, Missing or Damaged Parts  
Call: MASTERBUILT Customer Service at 1-800-489-1581

## CHARCOAL GRILLING RECIPES

### Tips for Grilling the Perfect Steak

- Allow 1/2 to 1lb per person for bone-in steak or 1 1/4lb per person for boneless steak.
- Choose steaks that are at least 1-inch thick.
- Bring steaks to room temperature. This makes it easier to estimate grilling time.
- Trim off fat to 1/8 inch and score edges to keep them from curling on the grill.
- On the grill, flip steaks when juices start bubbling on the un-cooked side.
- Second side of steak needs less grilling time than first.
- Salt & pepper each browned side of steak after turning.
- Test for doneness by making a knife slice beside bone.

### Original Ranch® Cheeseburgers

- 1 packet/1 oz. Hidden Valley® Original Ranch® Salad Dressing & Seasoning Mix
- 1 lb ground beef
- 1 cup shredded cheddar cheese
- 4 hamburger buns

Combine seasoning & salad dressing mix with beef and cheese. Shape into four (4) patties. Cook thoroughly until meat is no longer pink in center. Toast buns before serving, if desired. Serves 4.

### Grilled Hickory Beef Skewers

- 1lb flank or sirloin steak
- 1/2 cup KC Masterpiece® Barbecue Sauce (Original or Hickory)
- 3 tbs minced shallots or green onions
- 1 tbs lemon juice
- 1 1/2 tsp grated lemon peel
- 4 cloves garlic, pressed
- Pepper, to taste
- 16 skewers\*

Cut beef diagonally into thin strips about 1" wide. Thread onto skewers\*, allowing 1-2 ribbons of beef per skewer. In small bowl combine barbecue sauce, shallots, lemon juice, lemon peel, garlic and pepper. Brush skewered beef generously with sauce mixture. Place over hot coals in covered grill. Grill 2-3 minutes on each side. \*If using bamboo skewers, soak in water 30 minutes before use.

### Seafood Grill

- 1 1/2 cup KC Masterpiece® Original Barbecue Sauce
- 1/4 cup lemon juice
- 1 1/4 lb large prawns, shelled and deveined
- 1 1/4 lb large scallops
- 4-6 skewers\* (square-shaped skewers work best)

In bowl, combine barbecue sauce and lemon juice. Add prawns and scallops; let stand 30 minutes to marinate, mixing occasionally. Thread prawns and scallops on separate skewers. Place 6 inches over hot coals. Grill 2-3 minutes, baste, turn and baste again. Cook until prawns are pink and scallops are opaque, about 4-6 minutes total.

\*If using bamboo skewers, soak in water 30 minutes before use.

### Original Ranch® Pork Chops

- 1 packet / 1 oz Hidden Valley® Original Ranch® Salad Dressing & Seasoning Mix
- 1 1/4 tsp black pepper
- 6 pork chops (about 3/4 inch thick)
- Dash of paprika

Combine seasoning and salad dressing mix with pepper. Rub mixture on both sides of pork chops. Arrange pork on grill and sprinkle with paprika. Grill until cooked through. Serves 4-6.

### Grilled Red Potatoes with Hickory Brown Sugar Butter

- 8 red potatoes, 2-inch diameter (approx. 1 lb.)
- 2 tbs water
- 1/4 cup KC Masterpiece® Hickory Brown Sugar Barbecue Sauce
- 1/4 cup salted butter, melted

Peel off 1-inch strip of skin around the middle of each potato. In a small bowl, combine KC Masterpiece® Hickory Brown Sugar Barbecue Sauce and butter. Set aside. Place potatoes and water in a microwavable 1 quart dish. Microwave full power (100%), covered, 9 minutes until tender, stirring once. Drain. Place cooked potatoes around outer edge of coals and grill for 10 minutes, turning frequently and brushing with sauce mixture. Makes 4 Servings.

### Grilled Smoked Sausage

- 1 cup apricot or pineapple preserves
- 1 tablespoon lemon juice
- 1 1/2 pounds smoked sausage

Heat preserves in small saucepan until melted. Strain; set aside fruit pieces. Combine strained preserve liquid with lemon juice in a small bowl.

Oil hot grid to help prevent sticking. Grill whole sausage on an uncovered grill, over low Kingsford® briquets, 10 minutes. Halfway through cooking, baste with glaze, then turn and continue grilling until heated through. Remove sausage from grill; baste with glaze. Garnish with fruit pieces. Serves 6

### Over the Coals Spiced Popcorn

- 1/2 cup popcorn kernels or 8 cups popped popcorn
- 2 tablespoons butter or margarine
- 1/2 teaspoon Worcestershire sauce
- 1/2 teaspoon chili powder
- 1/2 teaspoon lemon pepper
- 1/4 teaspoon garlic powder
- 1/4 teaspoon onion powder
- 1/8 teaspoon salt

If desired, pop 1/2 cup popcorn over coals in long-handled fireplace corn popper. Hold directly over, but not touching, hot Kingsford® briquets; shake vigorously until corn is popped, 3 to 4 minutes.

In saucepan, combine remaining ingredients. Set on edge of grill to melt butter. Toss butter mixture with popped popcorn. Makes about 8 cups.

**APPROXIMATE GRILLING TIMES**

BEEF	SIZE	GRILLING TIME	INTERNAL TEMP
Steaks	¾" thick	3 to 4 min. /side	med rare 145°F
		4 to 5 min. /side	med 160°F
Kabobs	1" cubes	3 to 4 min. /side	145°F to 160°F
Hamburger patties	½" thick	3 to 4 min. /side	med 160°F
Roast, rolled rump	4 to 6 lbs.	18 to 22 min. /lb.	145°F to 160°F
Sirloin tip	3 ½ to 4 lbs.	20 to 25 min. /lb.	145°F to 160°F
Ribs, back	cut in 1-rib portions	10 min. /side	med 160°F
	half, 2 to 3 lbs.	10 to 12 min. /side	med rare 145°F
Tenderloin	whole, 4 to 6 lbs.	12 to 15 min. /side	med 160°F
PORK	SIZE	GRILLING TIME	INTERNAL TEMP
Chops, bone-in	¾" thick	3 to 4 min. /side	med 160°F
Chops, bone-out	1 ¼" thick	7 to 8 min. /side	med 160°F
Tenderloin	½" to 1 ½" lbs.	15 to 25 min. total	med 160°F
Ribs (indirect heat)	2 to 4 lbs.	1 1/2 to 2 hrs.	med 160°F
VENISON	SIZE	GRILLING TIME	INTERNAL TEMP
Roast, saddle or leg	6 to 7 lbs.	25 to 30 min. /lb.	145°F to 160°F
Steaks	¾" thick	6 to 7 min. /side	med 160°F
CHICKEN	SIZE	GRILLING TIME	INTERNAL TEMP
Broiler fryer (indirect heat)	3 to 4 lbs.	60 to 75 min.	in thigh 180°F
Cornish hens	18 to 24 oz.	45 to 55 min.	in thigh 180°F
Breast halves, bone-in	6 to 8 oz. each	10 to 15 min. /side	170°F
Breast halves, boneless	4 oz. each	6 to 8 min. /side	170°F
Legs or thighs	4 to 8 oz.	10 to 15 min. /side	180°F
Drumsticks	4 oz.	8 to 12 min. /side	180°F
Wings	2 to 3 oz.	8 to 12 min. /side	180°F

• When outside temperature is cooler than 65°F and/or altitude is above 3,500 feet, additional cooking time may be required. To insure that meat is completely cooked use a meat thermometer to test internal temperature.

• Lifting grill lid during cooking process may extend cooking time due to heat loss.

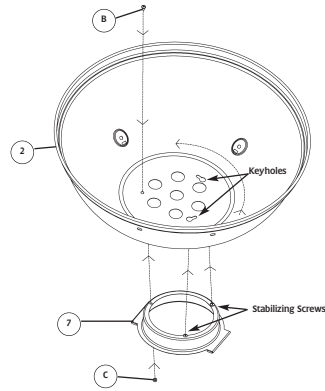

**Before assembly read instructions carefully.**

**Tools needed for assembly:**  
Adjustable Wrench  
Phillips Head Screwdriver

**Assemble grill on a clean, flat surface.**

**STEP 1.**  
Insert 2 stabilizing screws of ash can spacer ring (7) through keyholes in kettle base (2) and twist as shown. Secure with phillips head screw (B) and hex lock nut (C).

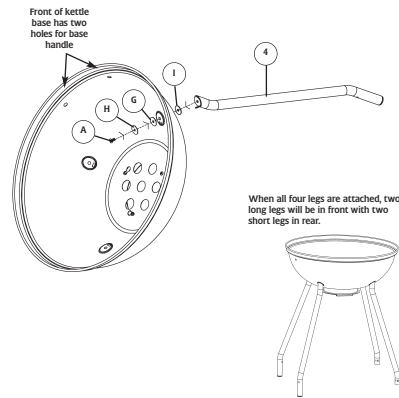

**Do not tighten screws all the way. Legs may need to be adjusted when storage shelf is attached in STEP 3.**

**STEP 2.**  
Place heat insulation washers (I) on long legs (4) as shown. Insert long leg tabs through front slot in kettle base. Secure with aluminum flat washers (G), steel flat washers (H) and phillips head screws (A).

Repeat step with short legs on rear side of kettle base.

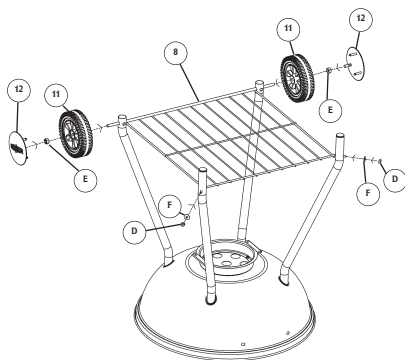

**Carefully reposition grill as shown. Be careful not to chip/scratch porcelain.**

**STEP 3.**

**Note:** Shelf may require tilting to place in position.

**Note:** Legs may need to be spread apart to place shelf in position.  
Insert storage shelf (8) into holes in grill legs as shown. Secure storage shelf to long legs using aluminum flat washers (F) and hex nuts (D).

Attach one wheel (11), indented side out, to each short leg. Then secure wheels and storage shelf to legs using nylon hex lock nuts (E).

Snap hubcaps (12) in place as shown.

**CHARCOAL LIGHTING INSTRUCTIONS**

**Read all instructions and warnings on charcoal bag and in manual before using.**

1. Stack briquets in a pyramid.
2. Add lighter fluid following directions on fluid container. Before lighting, place lighter fluid at least 25 feet away from grill. Do not lean over grill when lighting charcoal. Light charcoal. LEAVE GRILL UNCOVERED.
3. In about 15 minutes, flames will die out and briquets will begin to ash over. Once the briquets are completely ashed over, spread briquets in a single layer and begin cooking.

- **NEVER USE GASOLINE TO LIGHT CHARCOAL.**
- **OVERFILLING CHARCOAL GRATE CAN CAUSE SERIOUS INJURY AND DAMAGE THE UNIT.**
- **NEVER ADD ADDITIONAL LIGHTER FLUID ONCE CHARCOAL HAS IGNITED.**
- **HOT COALS SHOULD NOT BE LEFT UNATTENDED.**
- **GRILL IS HOT. USE PROTECTIVE GLOVES AND LONG, STURDY COOKING UTENSILS.**

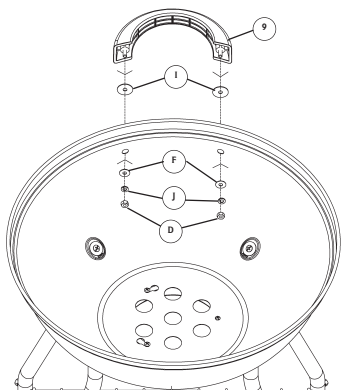

**Carefully reposition grill as shown.**

**Tighten all hardware on legs and storage shelf before continuing.**

**STEP 4.**

Place heat insulation washers (I) on base handle (9) as shown. Insert handle screws into holes in kettle base. Add aluminum flat washers (F), lock washers (J) and secure with hex nuts (D).

**THE HISTORY OF THE ORIGINAL CHARCOAL**

**In the 1920's**, Henry Ford realized that the wood scrap by-products created by the production of his Model T-Fords could be used as a slow-burning cooking fuel. As a result, Charcoal briquets were born. In building the charcoal plant, E.G. Kingsford, a relative of Ford's, brokered the deal for the manufacturing site that would produce these new charcoal briquets, Ford named Kingsford® Charcoal in his honor.

**Today**, the Kingsford Manufacturing Company remains the leading manufacturer of charcoal in the U.S. More than one million tons of wood scraps are converted into quality charcoal briquets every year. For more information about the Kingsford® Charcoal, please visit [www.kingsford.com](http://www.kingsford.com).

## GRILL OPERATION CAUTIONS

- Avoid bumping or impacting grill.
- Keep your hands, hair and face away from burning charcoal.
- This grill has an open flame. Be careful of loose hair and clothing during operation. They may catch fire.
- Use protective gloves when handling this grill or working with fire. Use protective gloves or long, sturdy fireplace tools when adding wood or charcoal.
- Do not allow anyone to conduct activities around this grill during or following its use until the unit has cooled. This grill is HOT during operation and remains HOT for a period of time following its use.
- Fatty foods like hamburgers can have excess grease that can cause flare ups. When cooking fatty foods, use caution when opening lid and during cooking to avoid being burned.
- Be careful when removing food from grill. All surfaces are HOT and may cause burns. Use protective gloves or long, sturdy cooking tools.
- Never use glass, plastic or ceramic cookware on this grill.
- The use of alcohol, prescription or non-prescription drugs may impair the user's ability to properly assemble or safely operate this grill.
- Grill lid and base are HOT while in use and during cooling process.
- Do not remove ash can while ashes and charcoal are HOT.
- Air dampers are HOT while the grill is in use and during cooling; wear protective gloves when adjusting.
- Never overfill charcoal grate. This can cause serious injury as well as damage the unit.
- Only use charcoal lighting fluid, never use gasoline, alcohol or other highly volatile fluids to ignite the charcoal. These fluids can explode causing injury or death.

**REMINDER:**  
NEVER OPERATE THIS GRILL UNDER ANY OVERHEAD CONSTRUCTION. MAINTAIN A MINIMUM DISTANCE OF 10 FEET FROM OVERHEAD CONSTRUCTION, WALLS OR RAILS.  
SEE DIAGRAM BELOW.

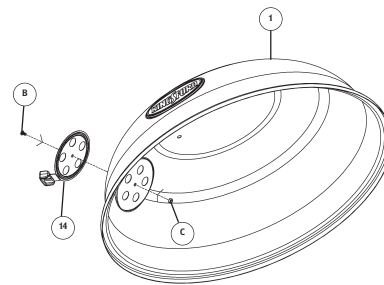
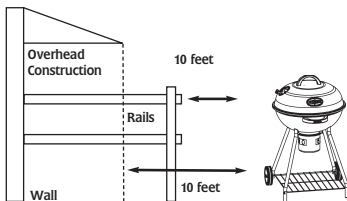

**STEP 5.**  
**Note:** Do not over tighten. Damper should move freely.

Attach lid air damper (14) to kettle lid (1) using phillips head screw (B) and hex lock nut (C).

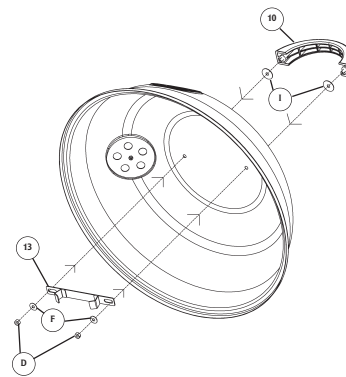

**STEP 6.**  
Place heat insulation washers (I) on kettle lid handle (10) as shown. Insert handle screws into holes in kettle lid. Add lid hook (13) then aluminum flat washers (F) and secure with hex nuts (D).

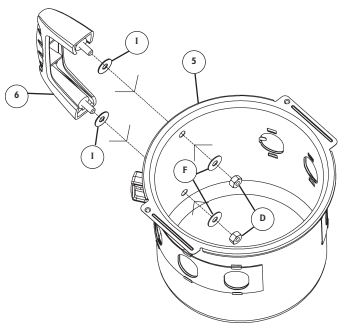

**STEP 7.**

Place heat insulation washers (I) on ash can handle (6) as shown. Insert handle into ash can (5) and secure using aluminum flat washers (F) and hex nuts (D).

**FREQUENTLY ASKED QUESTIONS REGARDING CHARCOAL GRILLS**

**Q. My charcoal grate has rust. How do I get rid of it?**

If rust occurs, clean with a steel brush. Reapply vegetable shortening and heat as indicated above.

**Q. When can I put my meat on the grill?**

Grill is ready for use when charcoal is ashed over and no visible flames are present.

**Q. How long will the briquets stay hot?**

If cooking for more than 30 to 40 minutes, additional briquets must be added to the fire. However, never add Match Light® briquets to an existing fire; add regular Kingsford® briquets in the following manner: Add 10 or 12 briquets to the outer edge of the fire immediately after it has been spread. Once these coals become 80% ashed over, add to the center of the fire as needed to maintain constant cooking temperature. **Read all instructions and warnings on charcoal bag.**

**Q. Can adjusting the vents on my grill make a difference?**

Vents on a covered grill are usually left open. This allows oxygen into the grill, increasing the temperature of the coals. Regulate the grill temperature by adjusting the vents. Closing them (either partially or completely) may help to "cool down" a fire that is too hot.

**SAFE STORAGE AND MAINTENANCE**

- Inspect hardware in assembled parts on a regular basis to insure grill is in safe working condition.
- ALWAYS allow grill to cool completely before handling.
- ALWAYS empty ash can after use only when ashes have completely cooled. This will help prolong ash can life.
- Clean grill, including special surfaces such as cooking grates with mild cleaning agents. Wipe outside of grill with damp rag. DO NOT use oven cleaner.
- ALWAYS cover and store cold grill in a protected area.
- Indoor storage of grill is permissible only if the charcoal has burned to a complete ash AND is cold. Remember to remove cold ashes before storing.
- Grill is made of steel and may rust over time. If rusting occurs on outside surfaces, clean area with sand paper or steel wool, then cover with heat resistant paint, except for stainless steel parts.
- If rusting occurs on the inside surface of grill, clean area with sandpaper or steel wool, then coat with cooking oil, except for stainless steel parts.
- NEVER USE PAINT ON INSIDE SURFACES OF GRILL

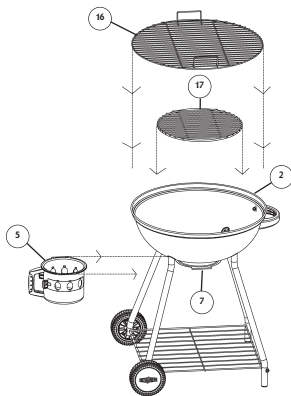

**STEP 8.**

Slide assembled ash can (5) onto guides of ash can spacer ring (7).

Place charcoal grate (17) inside kettle base (2). Tabs from legs will secure grate in place.

Rest cooking grate (16) on kettle base as shown.

**GRILL IS READY FOR USE.**