

This Owner's Manual is provided and hosted by [Appliance Factory Parts](#).



# KALAMAZOO K900HT Owner's Manual

[Shop genuine replacement parts for KALAMAZOO  
K900HT](#)



[Find Your KALAMAZOO Grill Parts - Select From 28 Models](#)

----- Manual continues below -----

# 2009 Outdoor Kitchen Resource Book

Kalamazoo Outdoor Gourmet, Bringing Gourmet Lifestyles Outdoors Since 1906™





# Outdoor Cooking Passion

Since 1906, the distinctive grills from Kalamazoo have enjoyed a loyal following among those who are passionate about cooking. Back then, a little sheet metal company run by an eccentric inventor and entrepreneur built the first grill bearing the Kalamazoo name. Over 100 years later, we are designing and building a complete collection of outdoor cooking and entertaining equipment that sets the standard for performance, quality and innovation.

Whether you dream of a custom outdoor kitchen with all the amenities, or simply want the ultimate grill for your patio, Kalamazoo Outdoor Gourmet™ is the name you need to know.

**Awesome Gas and Hybrid Grills** Our grills set the standard for outdoor cooking performance with superior power, a hassle-free cleanout system, unique custom laser-cut cooking surfaces and a full repertoire of cooking techniques. And, our revolutionary hybrid grills cook with any combination of charcoal, wood and gas for ultimate convenience and flavor. Learn more on pages 13 and 42.

**Intelligent Cabinets** Our complete line of outdoor kitchen cabinets are weather-tight, featuring seamless rain gutters around every door and drawer opening.

**Superior Refrigeration** Our refrigeration is engineered to easily conquer even desert heat, delivering greater cooling power while consuming less energy. Check out the performance chart on page 19.

**Versatile Options** Our wok cooktops, pizza oven, lobster boil pit and optional offset smoker box expand your outdoor cooking capabilities.

**Design Flexibility** Our modular outdoor kitchen system is easy to install, saving time and money. Each made-to-order piece is fully-finished on all sides in hand-rubbed stainless steel and stands on its own leveling legs. The design choice is yours — a gleaming, modern stainless steel kitchen or one incorporated into masonry, stucco or other finishes.

**Rugged Quality** Our materials and components are all designed, manufactured and selected to meet the highest standards of performance, quality and durability without compromise. We focus exclusively on being the best in outdoor cooking and entertaining equipment.

**Project Support** Our expert staff can help you design the ultimate outdoor cooking retreat, and we provide the complete CAD drawings that are critical to a successful installation.

## Contents

<b>Custom Outdoor Kitchen Collection</b>	2
<b>How to Order</b>	4
<b>System Design Basics</b>	6
<b>Sample Kitchen Plans</b>	7
<b>Collection Specifications</b>	
Built-In Grills	12
Grill Filler Panels	17
Refrigeration & Ice Maker	18
Refrigeration Cabinets & Fillers	28
Cooktops	30
Lobster Boiler	31
Warming Drawers	31
Base Cabinets	32
Sink Bases	35
Cabinet Accessories	36
<b>Pizza Oven</b>	38
<b>Free-Standing Grill Collection</b>	40
<b>Grill Accessories</b>	44
<b>Martini Bar</b>	46
<b>Oasis Award</b>	48
<b>Professional Partner Program</b>	50

"I may never cook indoors again."

— Chef Rick Bayless



# Custom Outdoor Kitchen Collection

Everything you need for the ultimate outdoor kitchen, including design support, is available from Kalamazoo Outdoor Gourmet. We work with design professionals and homeowners to plan the ideal outdoor cooking and entertaining retreat for each home.

**Flexible Style** Contemporary or classic, the choice is yours. All Kalamazoo equipment and cabinets are fully-finished in stainless steel. Add the countertop of your choice for a sleek and modern style in gleaming stainless steel. Or, integrate masonry, stucco, wood and other classic materials with our modular system for a versatile range of aesthetics. The design possibilities are endless.

**Design Basics** The modular Kalamazoo system is built on a standard depth of 30 inches so that every kitchen design can accommodate any of our high-performance grills. Every unit stands on stainless steel leveling legs, which can be covered with optional stainless steel toe-kicks or left exposed. Linear, L-shaped, U-shaped and island configurations are all possible using standard equipment and cabinets. See the planning guide on page 6.

**Outdoor Engineering** Everything Kalamazoo builds is designed from the ground-up to perform outdoors, including our cabinets. From the full-extension all stainless steel drawer glides — to the hinges and other marine-grade hardware — to the double-wall cabinet design and heavy-gauge material — every aspect of our construction speaks to the quality and durability of our outdoor kitchen cabinets. Most importantly, the seamless rain gutter surrounding every door and drawer opening makes each Kalamazoo cabinet a weather-tight vault — the only cabinets that will keep your tools, linens, serving pieces and spices clean and dry no matter what mother nature throws at them. Our cabinets and equipment are all designed for easy cleaning and low maintenance.

**Serious Performance** Industry experts, top chefs and customers agree that our grills simply out-perform all other options. Take a moment to review the performance data for our refrigeration on page 19, and you will see we're just as serious about our cooling as we are about bringing the heat.

**Extensive Collection** The broad array of equipment and cabinets available is designed to meet any outdoor cooking and entertaining need. More than 20 models are available in the outdoor refrigeration line alone.

**High-performance grills, including gas grills and hybrid grills for cooking with charcoal, wood and gas.**

**More than 20 refrigerated units, including refrigerators, freezers, wine chillers and keg tappers, plus the beverage center and clear ice maker.**

**More than 20 weather-tight cabinet designs including thoughtful features that make entertaining easier.**

**Wok-ready cooktops, a lobster boil pit, warming drawers and a pizza oven for expanded outdoor cooking capabilities.**

**Designer options like end-cap shelves, umbrella inserts and counter overhang brackets.**



“Kalamazoo will literally build the kitchen of your dreams outdoors.”

— Amy Covington, JustLuxe

**Outdoor Artisan Pizza Oven, page 38.**



# How to Order, Install and Enjoy

Kalamazoo outdoor kitchen design consultants assist with each project, from equipment selection, to kitchen layout, to the engineered drawings that help installations run smoothly.

**Partner with the Experts** Kalamazoo pioneered the outdoor kitchen with all its unique engineering and equipment needs. Our experts have seen it all and are here to help with everything from the most basic outdoor kitchen island applications to the most challenging problems and large-scale installations.

**Select the Equipment and Define the Rough Plan** How do you cook and entertain, and what do you want to accomplish with your outdoor kitchen? Selecting the right equipment and designing the right functional zones for the kitchen are an important first step. Kalamazoo works with homeowners and their chosen professionals to define the outdoor dream kitchen that works within the constraints of the project and site plan.

**Review Detailed Estimates** A Kalamazoo consultant will create a formal quote including the grills, cabinets, refrigeration and other equipment reflected in the rough plan.

**Receive CAD Drawings** For a small fee, our engineers will create CAD drawings of your Kalamazoo Custom Outdoor Kitchen. This fee is credited 100% toward the outdoor kitchen order. Detailed drawings help homeowners visualize the outdoor kitchen, and they help designers finalize every aspect of the design and equipment selection. Revisions are incorporated without hassle. Drawings include detailed dimensions and tolerances as well as gas, plumbing and electrical supply locations. The final drawings are a boon to installers. Kalamazoo can also create dimensioned counter drawings.

**Finalize the Order** Once the kitchen is finalized, Kalamazoo can usually build and ship the equipment within 4 to 6 weeks.

**Simple Installation** All of the equipment arrives fully assembled. We include the installation instructions, CAD drawings and hardware needed to efficiently build the kitchen. Simply align all of the units according to the plan, level with the adjustable legs and then bolt each unit to its neighbor. Add the provided counter supports and optional overhang brackets, and you are ready to install the counters.

**Support** We're just a phone call away to answer any questions during installation and the lifetime of outdoor cooking and entertaining enjoyment to follow.

**Kalamazoo creates complete CAD drawings to help with design, planning and installation.**

**All equipment is built-to-order and arrives fully assembled.**

**Stainless steel leveling legs on each grill and cabinet speed installation.**

**Equipment that is fully-finished on all sides means the kitchen can be ready to use as soon as the countertop can be installed, even as quickly as the delivery day.**

**Expert support from Kalamazoo sales, engineering and customer service make the order-to-delivery and installation process painless.**



**Recipes, tips and expert advice make using the best outdoor cooking and entertaining equipment even more enjoyable. Subscribe to our newsletter at [www.KalamazooGourmet.com](http://www.KalamazooGourmet.com).**

*"The outdoor kitchen is a destination in itself."*

*— Bill Marken, Garden Design*

# Kalamazoo System Design Basics

The Custom Outdoor Kitchen Collection by Kalamazoo eliminates many of the challenges inherent to designing the outdoor dream kitchen. Not only does the collection include every imaginable option for outdoor cooking and entertaining, the modular engineering makes design and installation easier.

**Free-Standing or Masonry Integration** A Kalamazoo outdoor kitchen is fully-finished in hand-rubbed stainless steel. There is no need to specify or order finishing panels to complete the look of a free-standing kitchen design. Each Kalamazoo outdoor kitchen cabinet is a complete unit with finished front, sides and back. The system is also fully compatible with masonry, stucco or other surrounds while reducing the labor required from these trades.

**Uniform Depth** All cabinets are 30" deep, including base cabinets, sink bases, appliance cabinets and accessories like the end cap shelves, 45-degree inserts and umbrella inserts. This depth allows the cabinets to clear the depth of the largest Kalamazoo grills. All back filler panels are designed to support the countertop behind system components that are less than 30" deep such as the grills and undercounter appliances. With a 1" overhang on all sides, the counter depth for a standard Kalamazoo outdoor kitchen is 32".

**Adjustable Height** All cabinets and grills stand on stainless steel leveling legs. These legs compensate for uneven surfaces and allow a range of finished counter heights. The system is optimized for 1.25"-thick solid surface counters with a counter height of 36". Cabinets have a range of adjustment of plus or minus 0.75". Grills can adjust plus or minus 1.5" to allow for higher or thicker countertops.

**Grill Options** Kalamazoo grills for use as built-in grills or in conjunction with Kalamazoo outdoor kitchen cabinets are available in two sizes, 864 square inches and 432 square inches. The installed widths are 38.3" and 26.87". These grills all include cabinets underneath for storage and hassle-free cleanout access. Kalamazoo does not make a "drop-in" grill. All grills stand on their own adjustable stainless steel legs (see the grill overview on page 12).

**Refrigeration Options** Kalamazoo offers a full range of refrigeration for undercounter installations in four widths: 15", 24", 48" and 72". The line includes wine chillers, keg tappers and beverage centers plus the only outdoor-rated freezers available and the only refrigerators suitable for food storage (see page 18).

**Appliance Cabinets** All appliance cabinets include GFCI electrical outlets inside to supply power to the appliances. The outlets must be hard-wired according to local codes. Appliance cabinets are available for 48", 24" and 15" appliances. Two 24" appliances can be installed in a 48" appliance cabinet. All appliance cabinets measure 9" wider than the appliance size (the appliance surround for 48" appliances is 57" wide). Appliance cabinets create an insulating air gap for appliances to be installed next to a grill.

**Appliance Back Filler Panels** All appliance back filler panels include GFCI electrical outlets to supply power to the appliances. The outlets must be hard-wired according to local codes. Back panels are available for 24" and 15" appliances. A back panel can only be used between a pair of cabinets. The panel mounts to these cabinets. Any two Kalamazoo cabinets can be used to flank the back panel, including base cabinets, sink bases, appliance cabinets or corner units. End cap shelves can also be used. Because a back panel is supported by the cabinets to either side, two back panels may not be used adjacent to each other. Back panels may not be used adjacent to a grill or the umbrella insert.

**Counter-Height and Bar-Height Seating** Counter overhang brackets are available to support a 10" to 12" counter overhang from the backs of Kalamazoo cabinets. Bar-height counter risers are also available as a custom order to create bar seating as part of the kitchen.

**Corner Options** Kalamazoo corner options include: 90-degree corner base cabinets and sink bases with a single door set at a 45-degree angle; blind corners to create a 90-degree bend with appropriate clearances in a minimum footprint; and 45-degree inserts that create a 45-degree angle between two legs of a kitchen. The 45-degree inserts also may be used to flank a grill or other equipment, highlighting that equipment as an angled corner.

**Toe Kicks** Optional stainless steel toe kicks are available for any or all four sides of the outdoor kitchen, including grills, base cabinets, sink bases and appliance cabinets.

# Sample Outdoor Kitchen Plans

**The Havana** [ 10' 1" x 3' 4" ]

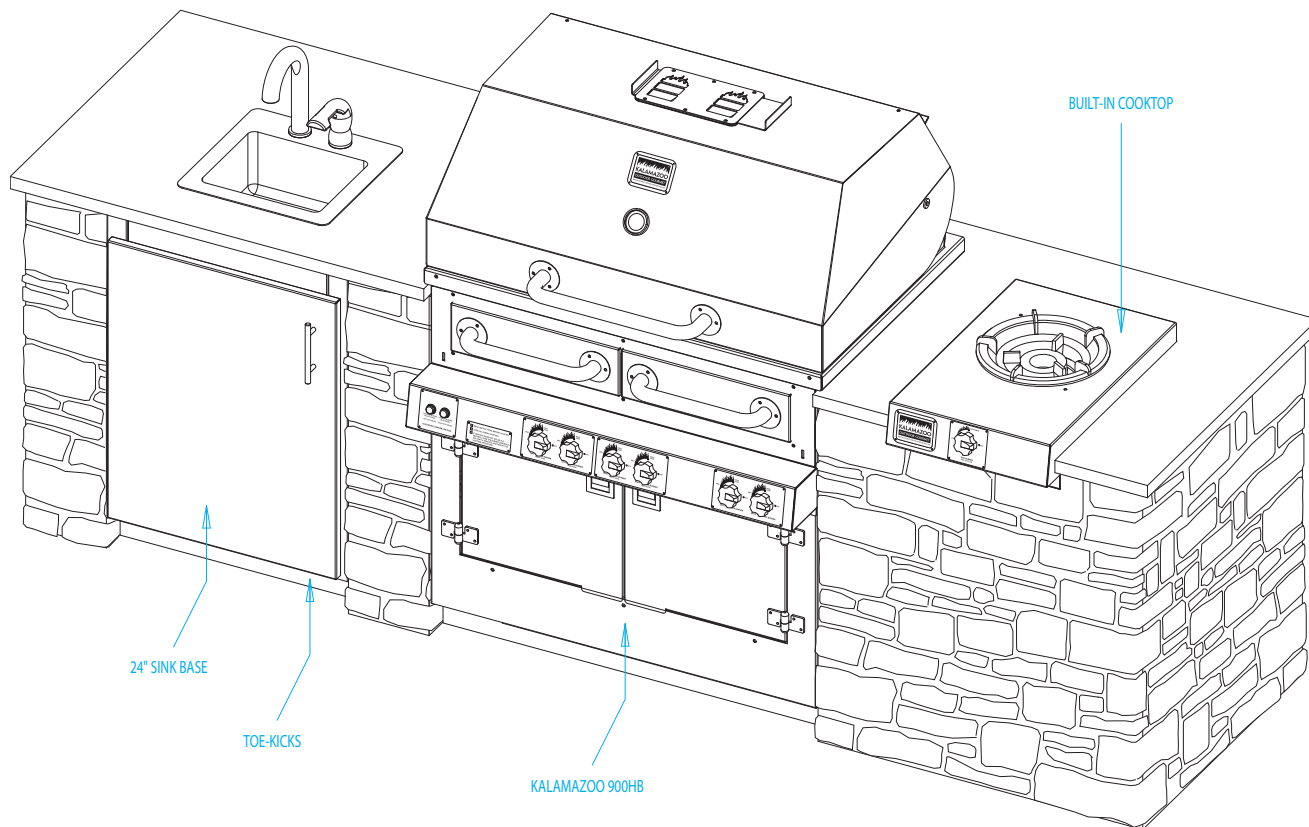

**The Essential** [ 11' 2" x 3' 0" ]

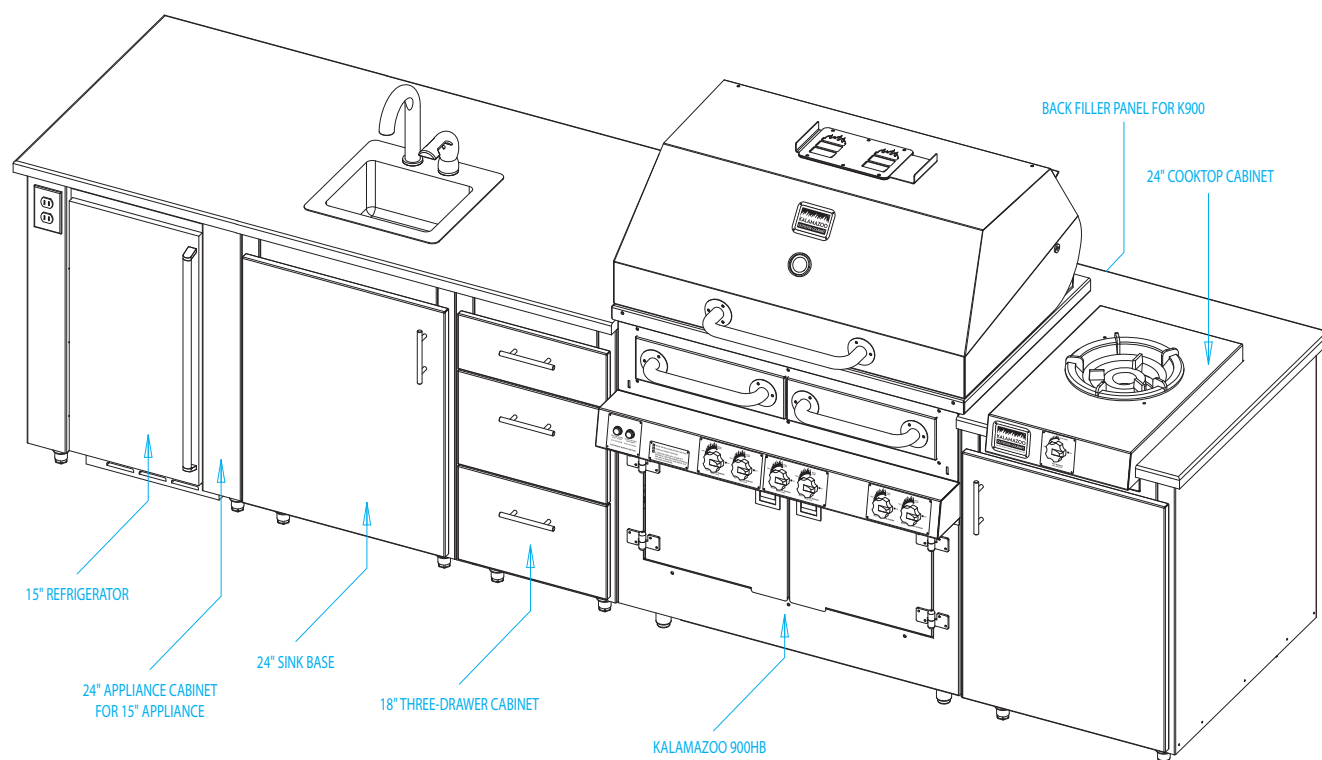

# Sample Outdoor Kitchen Plans (CONTINUED)

## The Oasis [ 16' 4" x 13' 8" ]

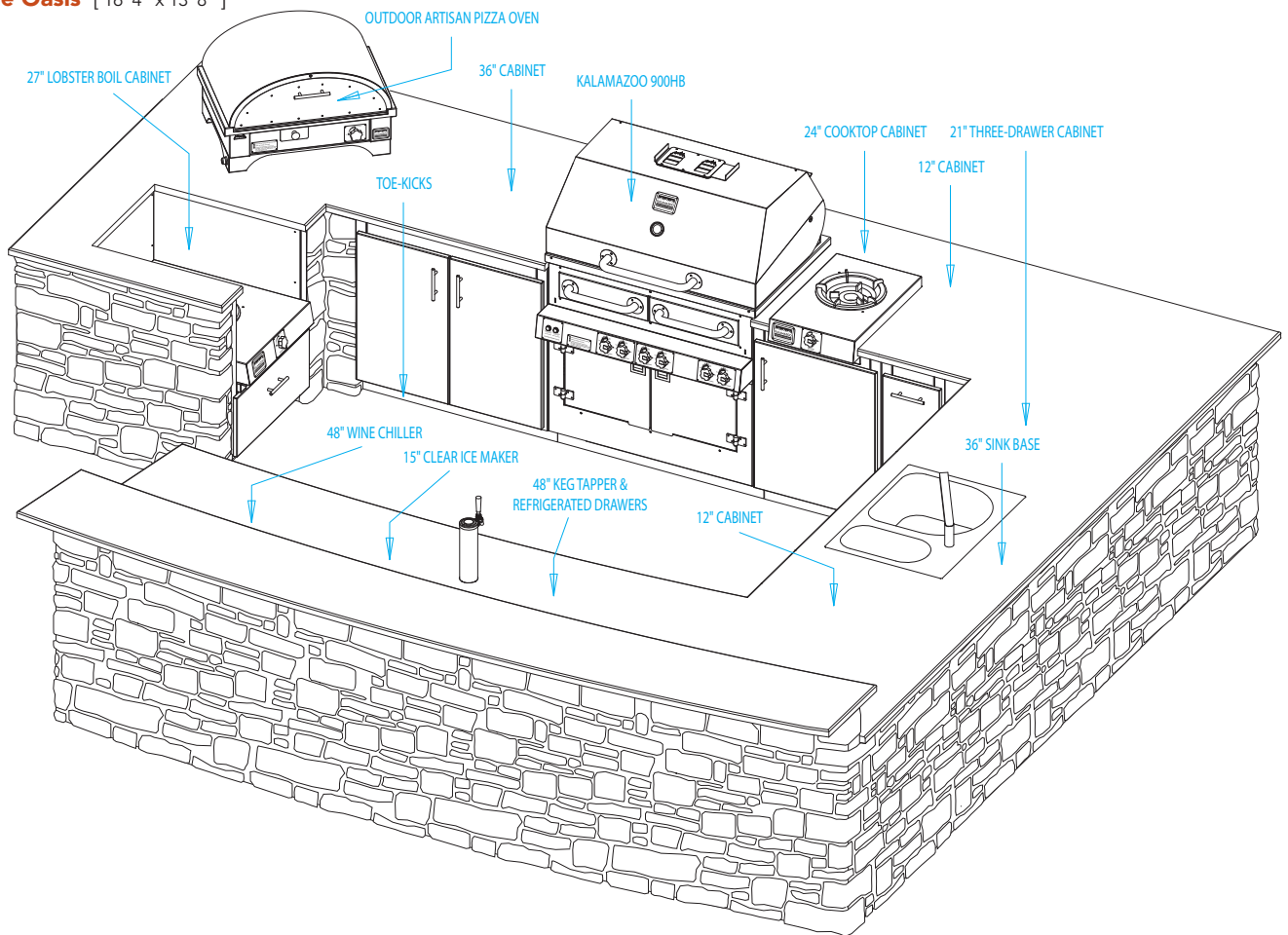

## The Oceanfront [ 19' 5" x 5' 6" ]

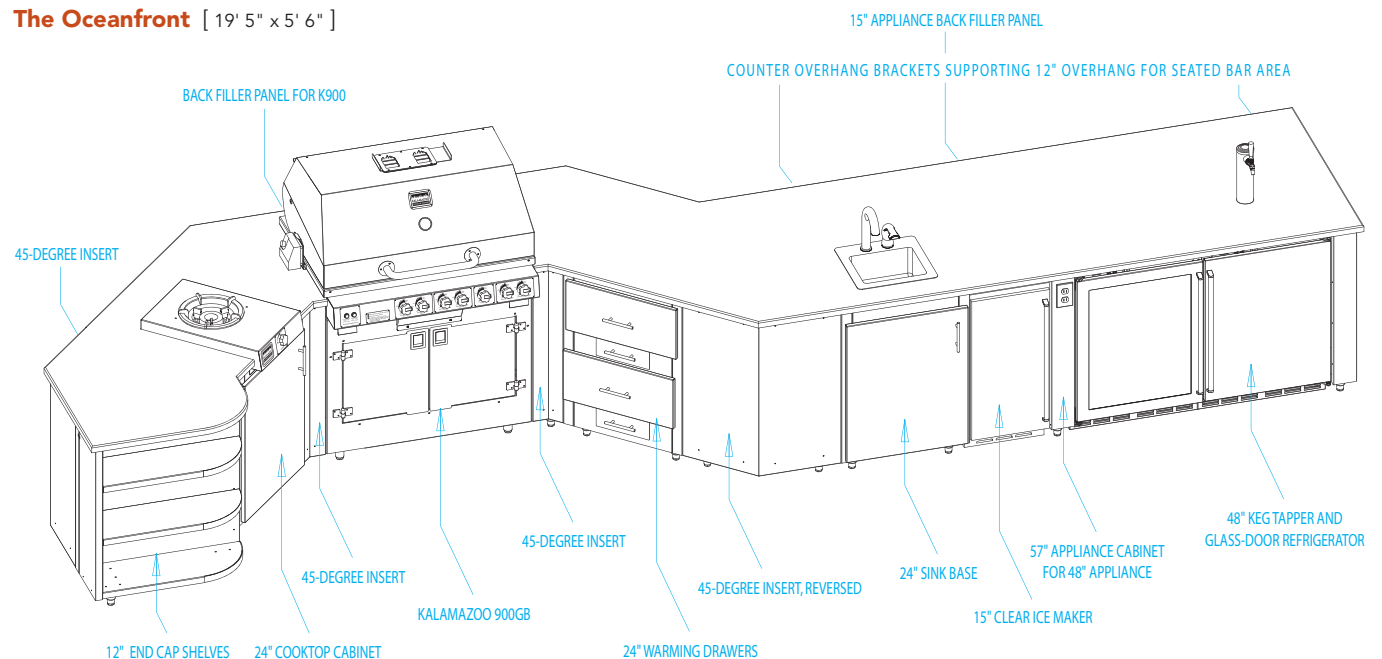

**The Club** [ 11' 5" x 8' 10" ]



**The Hampton** [ 10' 8" x 8' 7" ]

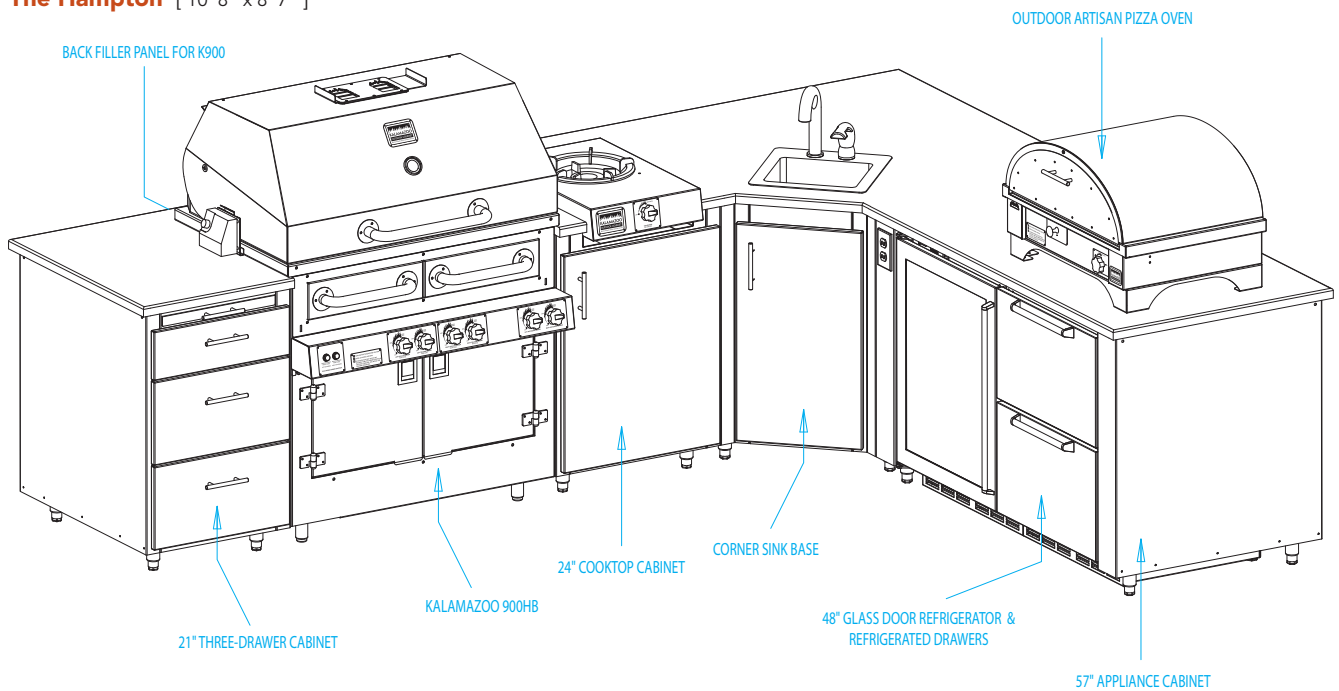

# Sample Outdoor Kitchen Plans (CONTINUED)

## The Villa [ 13' 5" x 12' 9" ]



## The Calistoga [ 17' 1" x 3' 0" ]

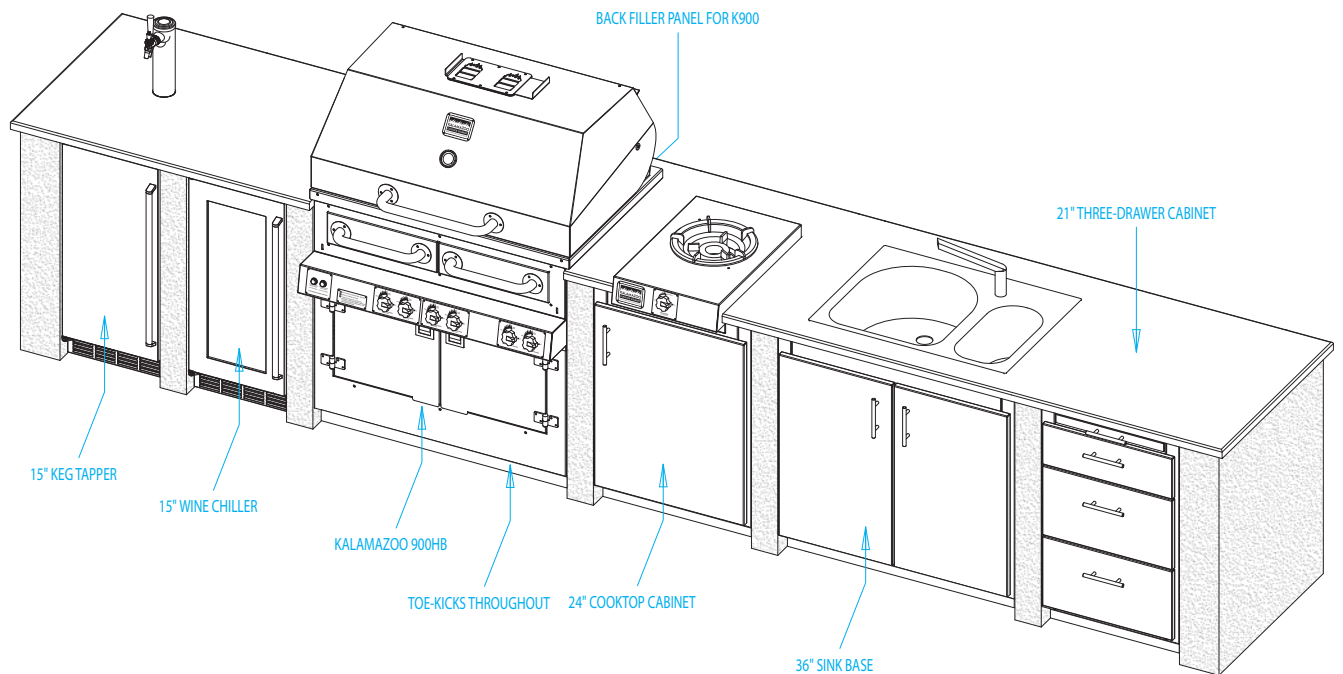

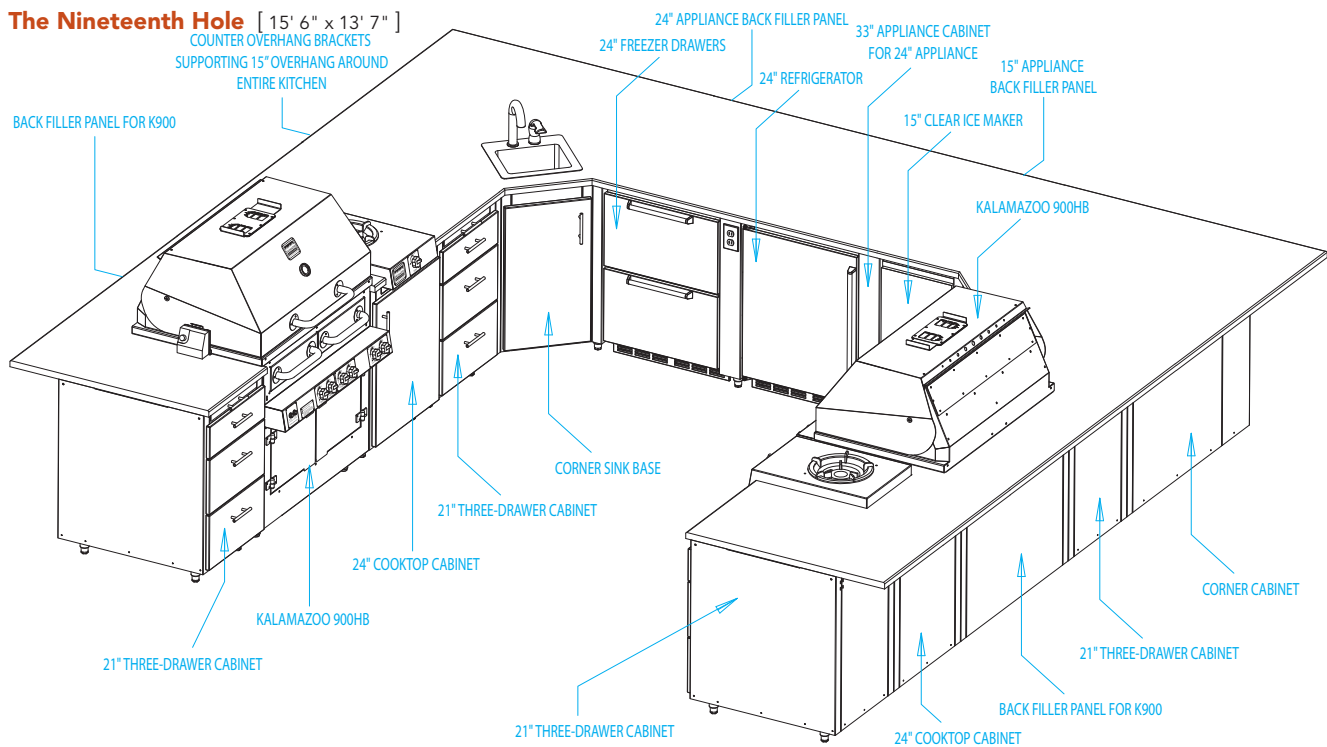
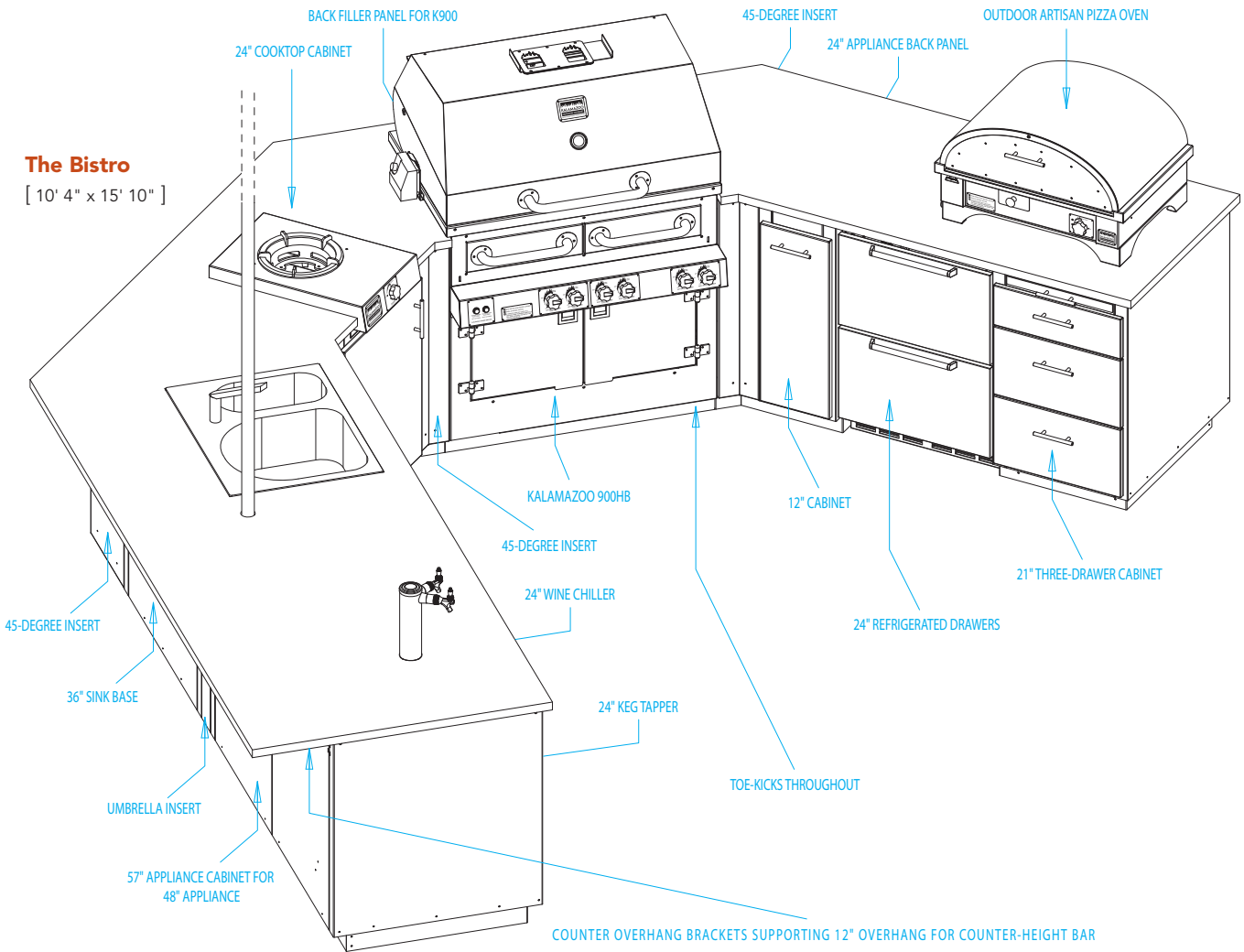



# No Other Grill Cooks Like a Kalamazoo

No wonder Kalamazoo grills inspire such a loyal following. Over 115 BTUs per square inch of primary cooking power. The ability to cook with any combination of charcoal, wood and gas. Real hassle-free cleaning. Custom cooking surfaces. The advantages are unrivaled.

**Hybrid Cooking with Charcoal, Wood and Gas** Changing fuels is as easy as opening the hybrid grilling drawer. Our powerful gas burners are located below the hybrid drawer system. Use the burners alone to cook with gas, or place wood or charcoal in the drawer. The gas burners can be used to quickly and conveniently start a wood or charcoal fire, or to maintain the heat for longer cooking sessions.

**Ultimate Versatility** Grilling, searing, roasting, smoking, wok cooking, rotisserie and even baking. The power and versatility of Kalamazoo grills enable home chefs to passionately pursue every cooking style they desire, on a grill that makes it look effortless.

**Custom Cooking Surfaces** Homeowners can select their ideal combination of cooking surface patterns optimized for meat, fish and vegetables. There is even a solid surface available for teppanyaki-style cooking. For even further personalization, initials, logos and other artwork can be cut into the surface. See page 45 for more information.

**Easy-to-Use Rotisserie Cradles** Forget the spit. Kalamazoo 450 and 900 Series grills come standard with a no-mess rotisserie cradle as part of the infrared rotisserie system.

**Integrated Cabinetry** All Kalamazoo built-in and free-standing grills come standard with integrated cabinetry for storage and access to the deep hopper cleanout and electronic ignition modules.

**Redundant Electronic Ignition** The electronic ignition on a Kalamazoo is a fully-redundant system. There are two independent electronic igniters wired to each burner for reliable starting.

**Hassle-Free Cleaning** Any ash, grease and debris funnel down the deep-hopper design into a cleanout pan that is large enough to hold everything and deep enough to be easy to handle. There are no shallow grease trays on a Kalamazoo to slosh all over your patio. Another benefit of the deep-hopper design is that 99% of flare-ups are eliminated.



**Built-in grills, page 14.**



**Free-standing grills, page 40.**



**Custom cooking surfaces, page 45.**

“The feature that really puts the Kalamazoo over the top is that you can easily switch between gas and charcoal or wood. It is as simple as opening the drawer!”

— Chef Rick Bayless

# Kalamazoo Built-In Grills



## Built-In Grills with Stainless Steel Cabinets

Kalamazoo is the only manufacturer to offer built-in grills that include their own stainless steel cabinets as a standard feature. Why? The Advanced Cooking Concept at the core of every grill we make utilizes a deep cookbox that extends far below the grilling surface for improved heat dynamics and a broader range of outdoor cooking techniques. And, the hassle-free cleaning system funnels down to a large and deep pan conveniently accessed within the cabinet. A Kalamazoo reaches all the way down to the patio and stands on its own adjustable leveling legs for easy installation.

Each Kalamazoo is built to last and covered by a lifetime warranty. We build the grills around a fully-welded stainless steel frame, and use much heavier-gauge stainless steel than our rivals, so much, in fact, that a Kalamazoo 900HB weighs-in at over 500 pounds.

### Kalamazoo 900HB Hybrid Built-In Grill K900HB

Hybrid grill cooks with charcoal, wood and gas

122,000 BTUs total cooking power

38.3" Wide

*Available in gas or hybrid charcoal, wood and gas models*

*432 square-inch (450 Series) or 864 square-inch (900 Series) primary grilling area*

*50,000 main burner BTUs (450 Series) or 100,000 main burner BTUs (900 Series) in 2 or 4 control zones*

*Infrared rotisserie cradle systems with 11,000 BTUs (450 Series) or 22,000 BTUs (900 Series) in 1 or 2 control zones*

*Hassle-free cleanout system*

*Optional custom laser-cut stainless steel cooking surfaces (see page 45)*

*Optional wok-ready cooktop (shown) (see page 30)*

*Available with 22,000 BTU infrared searing burner (K900G models only)*

*Natural gas standard, liquid propane configuration optional*

*Hand-built in 304 stainless steel on a fully-welded frame*



### Kalamazoo 900GB Gas Built-In Grill K900GB

Gas Grill

144,000 BTUs total cooking power

22,000 BTU infrared searing burner

38.3" Wide



### Kalamazoo 450HB Hybrid Built-In Grill K450HB

Hybrid grill cooks with charcoal, wood and gas

61,000 BTUs total cooking power

26.9" Wide



### Kalamazoo 450GB Gas Built-In Grill K450GB

Gas grill

61,000 BTUs total cooking power

26.9" Wide

# Kalamazoo Built-In Grills (DIMENSIONS)

## Kalamazoo 900HB Hybrid Built-In Grill K900HB



## Kalamazoo 900GB Gas Built-In Grill K900GB



# Kalamazoo Built-In Grills (DIMENSIONS CONTINUED)

## Kalamazoo 450HB Hybrid Built-In Grill K450HB



## Kalamazoo 450GB Gas Built-In Grill K450GB



# Back Filler Panels for Grills

Filler panels are available to bring the back side of a Kalamazoo grill installation flush with the backs of our 30"-deep kitchen cabinets and to support countertop spans behind the grill. Filler panels connect to, and are suspended between, Kalamazoo Outdoor Kitchen Cabinets on either side. Counter overhang brackets are available.

Filler panels are ideal for island kitchen installations. Your expert Kalamazoo Outdoor Kitchen Consultant can advise you regarding the use of these and other outdoor kitchen system components.

See page 32 for Kalamazoo Outdoor Kitchen Cabinets

See page 37 for Kalamazoo Counter Overhang Brackets

**Filler Panel for Kalamazoo 900 Series Built-In Grills  
K-BKFP-900B**



**Filler Panel for Kalamazoo 450 Series Built-In Grills  
K-BKFP-450B**





# Outdoor Refrigeration and Ice Maker

**Two Leaders, Working in Partnership** As the recognized leader in outdoor cooking and entertaining equipment, we demanded nothing short of the best when seeking a partner to manufacture our line of outdoor refrigeration. The search began and ended with Perlick, another Midwestern company with a long history of innovation and leadership. Perlick has been the top name in commercial refrigeration for over 90 years, and we are proud to say they manufacture our outdoor refrigeration line.

**Unrivaled Performance** Variable speed compressors, advanced insulation and forced air cooling add up to the most powerful and energy efficient outdoor refrigeration available. Check out the chart below comparing BTUs (a measurement of cooling power) and energy consumption among the most popular brands:

	Kalamazoo	U-line	Sub-Zero	Viking	Marvel	GE
BTU Output	995-1985	300-700	325	380	461	275
Energy Used (kWh/year)	311	339	334	N/A	N/A	360

Source: Perlick Corporation

**Industry Exclusives** Not only does a Kalamazoo outperform any other outdoor refrigeration unit, there are a number of outdoor appliances not available from any other manufacturer. We offer the only outdoor rated freezers and freezer drawers, keg tappers that can serve three types of beer and 15-inch refrigerated drawers. Our features are exclusive as well: full-extension vinyl-coated shelves that extend beyond the cabinet; variable speed compressors that keep the temperature even and use less energy; and 2 inches of rigid insulation surrounding every cabinet, plus glass doors replete with argon-charged “warm edge intercept” technology, for maximum insulating efficiency.

**Design Flexibility** Available in 15-, 24-, 48- and 72-inch widths for under-counter installation or freestanding use, Kalamazoo offers more choices for the outdoor kitchen than any other manufacturer.

## Commercial History

Since 1917 Perlick has been the market share leader in the restaurant and bar business

More than 60% of Professional sports stadiums use Perlick Commercial Products

## Full-extension Pullout Shelving

Industry exclusive feature

Stainless steel ball bearing glides ensure smooth extension

Makes finding the right beverage easy

## Stainless Steel Interior

Commercial-grade stainless steel interior

Easy to clean and odor resistant

## Variable Speed Compressor

Quietest and most energy efficient compressor available

Delivers consistent temperature

Uses half of the energy of a standard compressor

## Full Two Year Warranty

Entire unit covered for two full years

Additional 4 years for parts on the sealed refrigeration system

Reliable and dependable

“...the only under-counter refrigerator in the industry with the ability to store food, as well as beverages.”

— Danny Lipford, CBS News

# Outdoor Refrigerators



**24" Refrigerated Drawers**  
K-H1R-O-D5

Two stainless drawers are ideal for keeping meats separate from produce, beverages and other items

Drawer locks available

With quality design and construction, outdoor refrigeration means more than just keeping your foods and beverages at the perfect temperature with unmatched uniformity. It means doing it with a supreme sense of style accompanied by a host of details that make each outdoor refrigerator a pleasure to own. Kalamazoo offers the first outdoor refrigerator with a glass door that can properly and beautifully store food in addition to beverages. Replete with unique and patent-pending features, these beautiful products combine the ultimate in performance and design.

*Commercial-grade stainless steel interiors*

*Electronic digital temperature control and display*

*Exclusive Variable Speed Compressor provides precise temperature control and energy-efficient cooling*

*Vinyl coated full-extension shelving, complete with guard rails, glide out beyond the cabinet for easy access to contents*

*Can be used as stand-alone units or installed as undercounter cabinets*

*UL approved for outdoor use*

*Two-inch thick walls provide superior insulation and minimize vibrations*

*Energy Star® qualified*

*Unprecedented 995 -1985 BTUs of cooling power*



**15" Refrigerator**  
HP15R-O-D1

Door lock available

Left- or right-hinge



**15" Refrigerated Drawers**  
HP15R-O-D5

EXCLUSIVE!

Drawer locks available



**15" Glass-Door Refrigerator**  
HP15R-O-D3

Door lock available

Left- or right-hinge



**24" Refrigerator**  
K-H1R-O-D1

Door lock available

Left- or right-hinge



**48" Refrigerator**  
K-H2RO-O-D1-D1

Door locks available



**48" Refrigerator and Refrigerated Drawers**  
K-H2RO-O-D5-D1

Door and drawer locks available



**24" Glass-Door Refrigerator**  
**K-H1R-O-D3**

Door lock available  
Left- or right-hinge



**48" Glass-Door Refrigerator  
and Refrigerated Drawers**  
**K-H2RO-O-D5-D3**

Door lock available (for door only)



**48" Refrigerated Drawers**  
**K-H2RO-O-D5-D5**

## Outdoor Wine Chillers

For the serious wine connoisseur, the only choice for outdoor storage of prized vintages is Kalamazoo Outdoor Gourmet. Unmatched temperature uniformity is provided with the use of the Variable Speed Compressor, which also reduces vibration and conserves energy. Vinyl coated full-extension shelving prevents bottles from shifting or slipping, and glass doors protect varietals from ultraviolet light while displaying the collection. Finally, we offer extraordinary storage capacity: the 72" three-door unit can hold up to 138 bottles of your favorite varietals.

*For stand-alone use or as undercounter cabinets*

*Commercial-grade stainless steel interiors*

*Electronic digital temperature control and display*

*Exclusive Variable Speed Compressor provides precise temperature control and energy-efficient cooling*

*Vinyl coated full-extension shelving glides out beyond the cabinet*

*UL approved for outdoor use*

*Two-inch thick walls provide superior insulation and minimize vibrations*

*Same energy-efficient design as our Energy Star® qualified outdoor refrigerators*

*Glass doors offer full UV protection*



**24" Wine Chiller**  
**K-H1W-O-D3**

42-bottle capacity  
Door lock available  
Left- or right-hinge



**15" Wine Chiller**  
**K-HP15W-O-D3**

24-bottle capacity  
Door lock available  
Left- or right-hinge



**48" Wine Chiller**  
**K-H2WO-O-D3-D3**

90-bottle capacity  
Door locks available  
Left- or right-hinge



**72" Wine Chiller**  
**K-H3WOO-O-D3-D3-D3**

138-bottle capacity  
Door locks available  
Left- or right-hinge

# Outdoor Keg Tappers



**48" Keg Tapper and Refrigerated Drawers**  
**K-H2RT-O-D5-HKEG2**

1, 2 or 3 taps for up to three types of beer  
 Tap locks available  
 Door and drawer locks available

The luxury of enjoying a draught beer in your home outdoor kitchen achieves a new level with a Kalamazoo Outdoor Gourmet Keg Tapper. Perlick, manufacturer of all our outdoor refrigeration, has been the top name in commercial beer dispensing equipment since before prohibition. Today, you can avail yourself to a wide range of choices for your home needs, including models with one, two and even three taps. No other manufacturer enables you to serve three different types of beer.

*Commercial-grade stainless steel interiors*

*Electronic digital temperature control and display*

*Exclusive Variable Speed Compressor provides precise temperature control and energy-efficient cooling*

*Available with one, two or three taps to accommodate up to three different types of beer*

*Ability to combine with refrigerator for the ultimate in entertaining and flexibility*

*Suitable for stand-alone use or installation as an undercounter cabinet*

*UL approved for outdoor use*

*Two-inch thick walls provide superior insulation and minimize vibrations*

*Energy Star® qualified*

*European keg adapters available*



**15" Keg Tapper**  
**K-HP15T-O-D1**

Single tap  
 Tap lock available  
 Door lock available  
 Left- or right-hinge



**24" Keg Tapper**  
**K-H1T-O-D1-HKEG2**

1 or 2 taps  
 Tap locks available  
 Door lock available  
 Left- or right-hinge



**48" Keg Tapper and Refrigerator**  
**K-H2RT-O-D1-HKEG2**

1, 2 or 3 taps for up to three types of beer  
 Tap locks available  
 Door locks available



**48" Keg Tapper and Glass-Door Refrigerator**  
**K-H2RT-O-D3-HKEG2**

1, 2 or 3 taps for up to three types of beer  
 Tap locks available  
 Door locks available

# Outdoor Beverage Centers

Kalamazoo outdoor beverage centers combine the attractive wine storage and full-extension vinyl-coated shelves of our outdoor wine chillers with standard refrigeration space.

*For stand-alone use or as undercounter cabinets*

*Commercial-grade stainless steel interiors*

*Electronic digital temperature control and display*

*Exclusive Variable Speed Compressor provides precise temperature control and energy-efficient cooling*

*Two vinyl coated full-extension wine storage shelves glide out beyond the cabinet for easy access*

*A single vinyl-coated wire refrigerator shelf does the same.*

*UL approved for outdoor use*

*Two-inch thick walls provide superior insulation and minimize vibrations*

*Energy Star® qualified*

*Glass doors offer full UV protection*



**15" Beverage Center**  
**K-HP15B-O-D3**

Left- or right-hinge

Door lock available



**24" Beverage Center**  
**K-H1B-O-D3**

Left- or right-hinge

Door lock available

---

# Outdoor Freezers

Quiet, powerful and energy efficient, all Kalamazoo Outdoor Gourmet freezer cabinets feature forced-air ventilation, automatic hot gas defrost, and Perlick's unique Variable Speed Compressor. To ensure we meet all of your entertaining needs, the freezers also feature optional vinyl coated racks for storing martini glasses and beer mugs as well as storage racks for vodka or other liquors.

*Commercial-grade stainless steel interiors*

*Electronic digital temperature control and display*

*Exclusive Variable Speed Compressor provides precise temperature control and energy-efficient cooling*

*Suitable for stand-alone use or installation as an undercounter cabinet*

*UL approved for outdoor use — the only outdoor freezers available*



**24" Freezer**  
**K-H1F-O-D1**

Left- or right-hinge

Door lock available

Martini glass chiller rack available



**24" Freezer Drawers**  
**K-H1F-O-D5**

Drawer locks available

# Outdoor Clear Ice Maker



## 15" Clear Ice Maker K-H53IMS-O

Left-hinge only

Drain pump available

Measuring a mere 15 inches wide, the Kalamazoo Outdoor Gourmet Clear Ice Maker can create up to 50 pounds of crystal-clear ice in a single day (and stores up to 30 pounds), fulfilling even the most generous home entertaining needs. The distinctive top hat shape of each cube is more than just attractive: the shape helps ensure that each cube is absolutely free of impurities, for a flawless look and taste. This unique shape also prevents the ice from clumping, guaranteeing that you always serve your guests the perfect beverage every time.

*Produces up to 50 pounds of ice per day and stores up to 30 pounds of ice*

*UL approved for outdoor use*

*Quiet, efficient operation*

*Optional drain pump*

*Elegant stainless steel door and polished handle*

*Can be used as a stand-alone ice maker or installed as an undercounter cabinet. Sides, front and top are all finished in stainless steel*

# Outdoor Refrigeration Dimensions

## All Outdoor 15" Refrigerated Cabinets EXCEPT CLEAR ICE MAKER

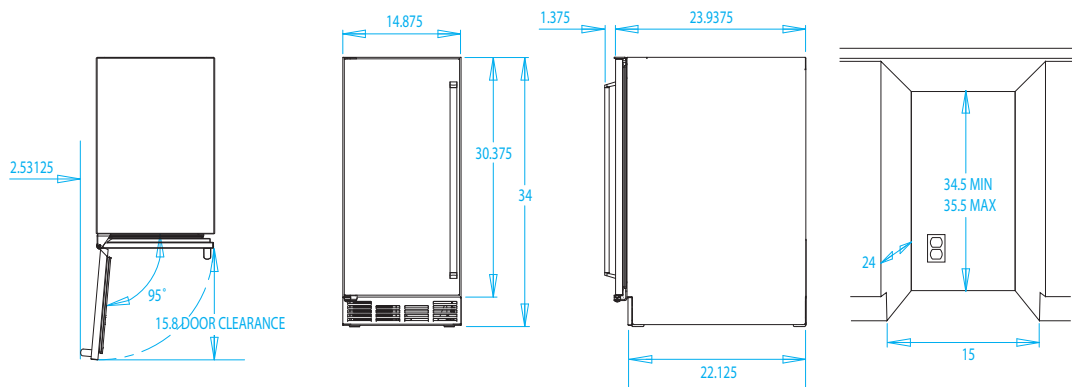

## Tap Dimensions on 15" Units

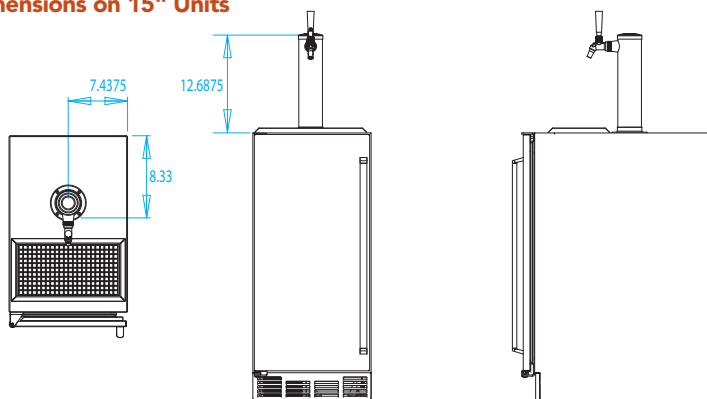

**Outdoor 15" Clear Ice Maker**



**All Outdoor 24" Refrigerated Cabinets**



**Tap Dimensions on 24" Units**

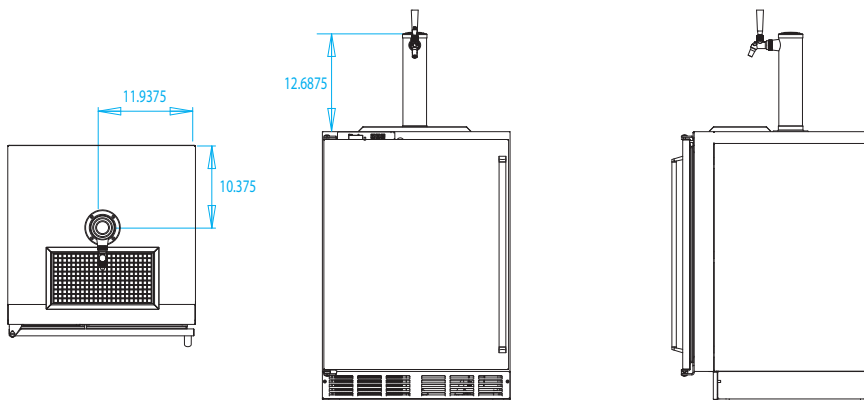

# Outdoor Refrigeration Dimensions (CONTINUED)

## All Outdoor 48" Refrigerated Cabinets

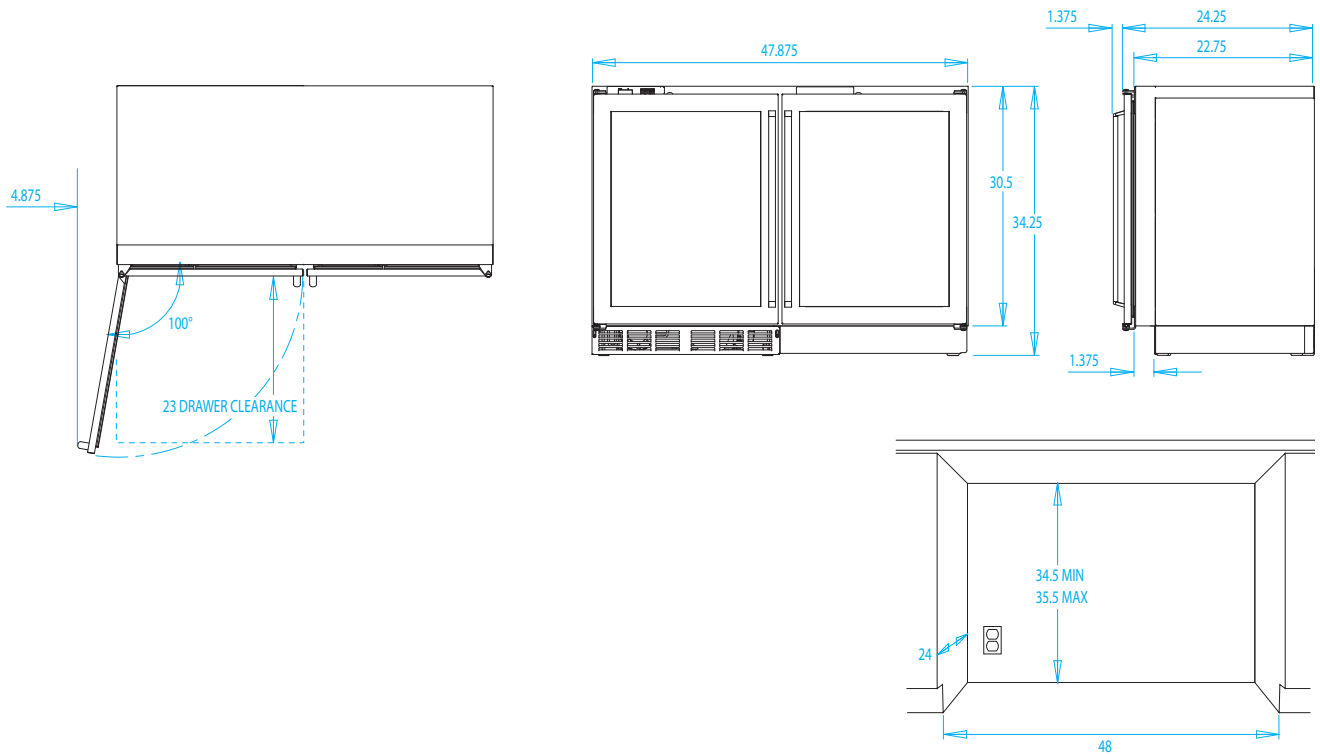

## Tap Dimensions on 48" Units

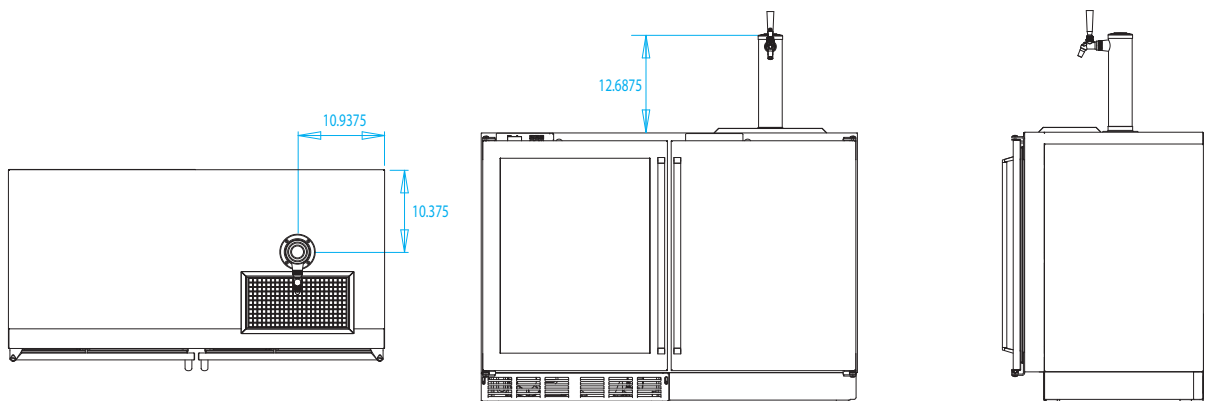

72" Outdoor Wine Chiller



# Outdoor Appliance Cabinets



**Appliance Cabinet with 15" Outdoor Clear Ice Maker**

Appliance cabinets offer an easy way to integrate outdoor appliances into a Kalamazoo outdoor kitchen. Each surround features electrical outlets within the cabinet for powering the appliance(s) as well as a pair of convenient power outlets on the front to power countertop electrics.

Appliance cabinets are a uniform 30" depth, the same as all other Kalamazoo outdoor kitchen cabinets and are built entirely from 304 stainless steel.

Appliance cabinets insulate appliances for use adjacent to the grill and are suitable for exposed ends of cabinet runs. See appliance back panels (page 29) for additional options when the appliance will be located between two cabinets.

*Available for 15", 24" and 48" undercounter outdoor appliances*

*GFCI outlets inside cabinet to power appliance(s)*

*GFCI outlets on face of cabinet for convenience*

*Countertops shown in this section are for illustrative purposes only*

*Toe-kicks available*



**Appliance Cabinet for 15" Undercounter Appliance  
K-ANC-15-24**



**Appliance Cabinet for 24" Undercounter Appliance  
K-ANC-24-33**



**Appliance Cabinet for 48" Undercounter Appliance**  
**K-ANC-48-57**



# Outdoor Appliance Back Panels

Appliance back panels can be used between two Kalamazoo outdoor kitchen cabinets to support the countertop, creating a uniform 30"-deep kitchen with a finished back. Appliance back panels may not be used next to a grill or at the exposed end of a cabinet run, but may be used between any two Kalamazoo base cabinets, sink bases or appliance cabinets.

Available for 15" or 24" undercounter appliances

GFCI outlets inside back panel to power appliance

**Appliance Back Panel for 15" Undercounter Appliance**  
**K-ABK-15**



**Appliance Back Panel for 24" Undercounter Appliance**  
**K-ABK-24**

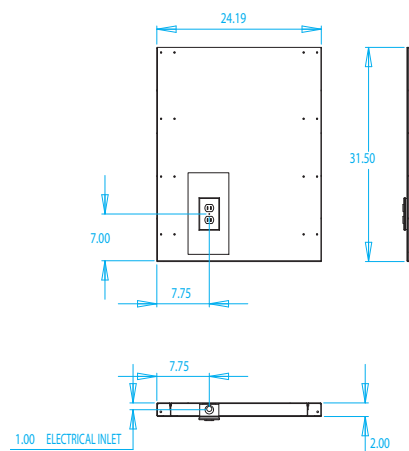

# Cooktops and Lobster Boiler



Why settle for a run-of-the-mill side burner when you can have a 32,000 BTU wok-ready cooktop in your outdoor kitchen? Our ingenious design uses four concentric rings of fire. To simmer sauces and glazes at low temperatures, the two inner rings provide controlled heat. Turn the burner up to high and all four rings kick in for rapid boiling or other high-temperature work.

Kalamazoo cooktops are available for built-in installations (photo at left) or mounted in a convenient storage cabinet. The lower cooking platform of our lobster boiler is ideal for large pots.

*Countertops shown in this section are for illustrative purposes only.*

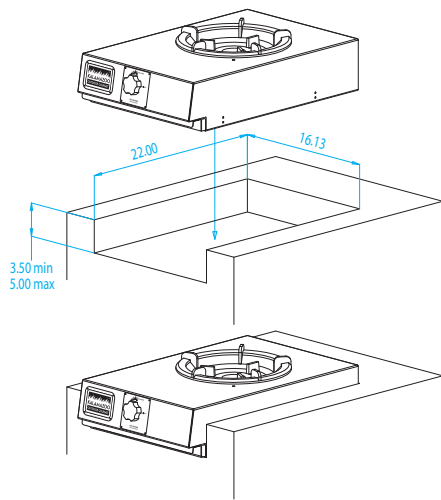

## Cooktop for Built-In Installations

**KKBI**

Natural gas standard, liquid propane an option

Custom stainless steel griddle available (see page 45)

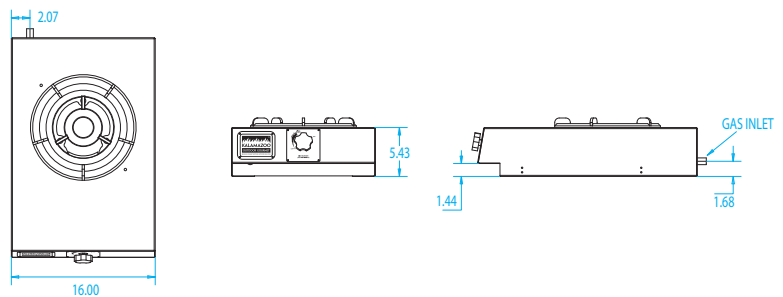

## 24" Cooktop Cabinet

**K-CKTP-24**

Includes glide-out bottom tray and utensil tray with hooks ideal for hot pads and tools

Kalamazoo weather-tight rain gutter

Natural gas standard, liquid propane configuration optional

Left- or right-hinge

Toe-kicks available

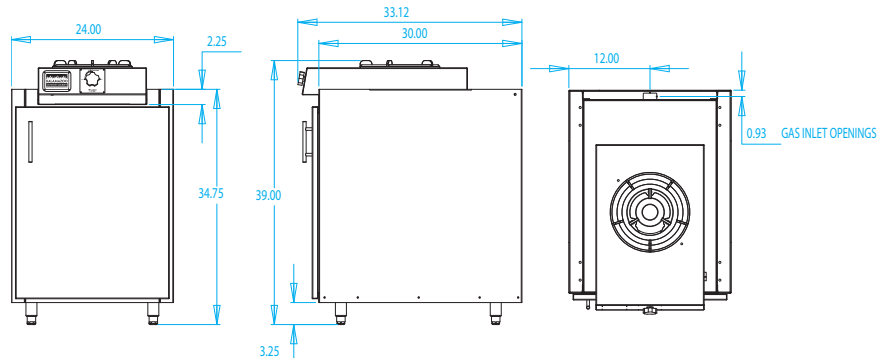

**27" Lobster Boil Cabinet**  
**K-BOLR-27**

Includes storage drawer  
Kalamazoo weather-tight rain gutter  
Natural gas standard, liquid propane configuration optional  
Toe-kicks available



# Warming Drawers

Keep food hot and ready to serve or use as a warmer for serving trays and dishes. Sterno fuel is safe and reliable, and it means you don't need extra electrical service in your outdoor kitchen in order to enjoy the convenience of warming drawers.

**24" Warming Drawers**  
**K-WDR-24**

Two sterno-fueled warming drawers keep food at serving temperature  
Kalamazoo weather-tight rain gutters  
Includes 2 large stainless steel hotel pans with lids and 4 sterno holders  
Stainless steel leveling legs  
Toe-kicks available



# Weather-Tight Outdoor Base Cabinets



Each cabinet features a weather-tight design with a seamless rain gutter surrounding every door and drawer opening. The system is a uniform 30-inches deep and installation is simple. Align and level the units with the standard stainless steel leveling legs, bolt them together with the included hardware and finish with your choice of custom countertop.

*Stainless steel construction, including all hardware*

*Full-extension stainless steel drawer glides*

*Weather-tight design*

*Fully-finished on all sides*

*Stainless steel leveling legs*

*Counter support brackets available*

*Toe-kicks available*

*Countertops shown in this section are for illustrative purposes only*



## **21" 3-Drawer Cabinet** **K-3DRW-21**

Kalamazoo weather-tight rain gutters

Integrated cutting board (see 24" cabinet photo at right)



## **18" 3-Drawer Cabinet** **K-3DRW-18**

Kalamazoo weather-tight rain gutters



---

**24" Cabinet**  
**K-STOR-24**

Kalamazoo weather-tight rain gutters

Integrated cutting board

Left-hinge or right-hinge available



---

**36" Cabinet**  
**K-STOR-36**

Kalamazoo weather-tight rain gutters

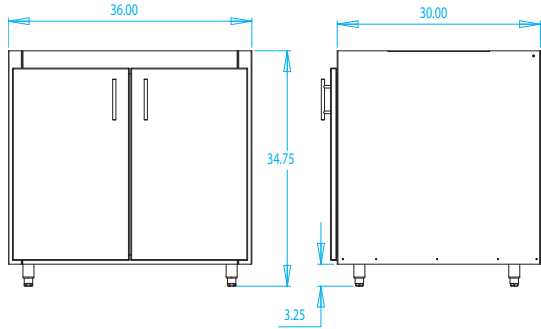

---

**24" Waste and Recycling Cabinet**  
**K-RY-24**

Kalamazoo weather-tight rain gutters

2 lidded waste cans included in full-extension rack

Integrated cutting board

Left-hinge or right-hinge available



# Base Cabinets (CONTINUED)



**12" Cabinet with Pull-Out Rack**  
**K-STOR-12**

Kalamazoo weather-tight rain gutters  
 Convenient storage in a compact footprint



**Corner Cabinet**  
**K-STOR-CRNR-SQR**

Kalamazoo weather-tight rain gutters  
 Creates a 90-degree bend with storage  
 Left-hinge or right-hinge available  
 See also 45-degree inserts (page 37) and  
 blind corner (page 36)



# Weather-Tight Outdoor Sink Bases

## 24" Sink Base

**K-SNKBR-24**

Kalamazoo weather-tight rain gutters

Designed for 14" bar/hospitality sink

Left-hinge or right-hinge available



## 36" Sink Base

**K-SNKDBL-36**

Kalamazoo weather-tight rain gutters

Fits over-mount sink for 36" cabinets or under-mount sink for 27" cabinets



## Corner Sink Base

**K-SNK-CRNR-SQR**

Kalamazoo weather-tight rain gutters

Fits over-mount sink up to 21" wide or under-mount sink up to 17" wide (larger sinks may fit depending on shape and placement)

Left-hinge or right-hinge available

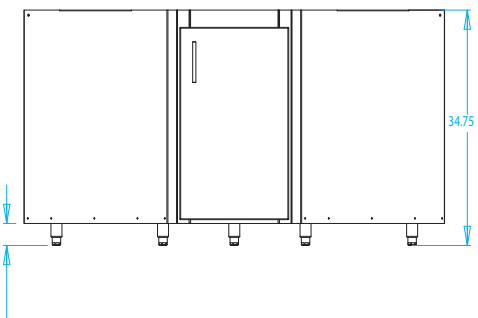

# Outdoor Base Cabinet Accessories



**Undercounter End Cap Shelves**  
**K-SHCP-12**

Left and right ends available

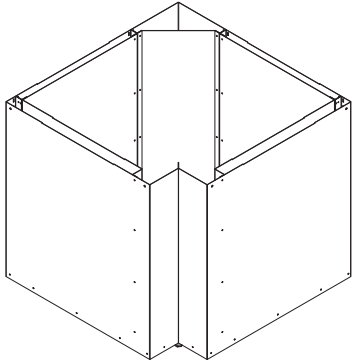

**Blind Corner Filler**  
**K-BLND-CRNR-SQR**

Forms 90-degree bend with 6" reveal at front for clearance  
 Minimal footprint with no storage



---

**45° Insert**  
**K-45-CRNR**

Forms 45-degree bend with 3" reveal at front for clearance



---

**Umbrella Insert**  
**K-UMB**

Holds a market umbrella to shelter the kitchen  
Requires corresponding hole in countertop



---

**Toe Kicks**

Custom stainless steel toe-kicks are available for front, sides and/or backs of all cabinets (excluding end cap shelves).

---

**Counter Overhang Brackets**  
**K-CBKT**

Brackets are available to support a 12-inch counter overhang  
Brackets mount to backs of cabinets





# Artisan Pizza in Your Own Backyard

Ovens lined with stone and topped by an arched roof are found across Italy for baking pizza and bread. Why? The stone creates a perfect crust and the low, arched top reflects radiant heat back to the pizza for even baking from both the top and bottom.

Kalamazoo Outdoor Gourmet has taken the classic pizza oven design and updated it in stainless steel for worry-free outdoor use with the Outdoor Artisan Pizza Oven.

**Professional Pizza Stone** The cooking surface is a professional composite baking stone. Its heat transfer characteristics exceed that of natural stone, and the composite material will never become brittle like quarry stone can after repeated heat cycles.

**Precision Control** The high-performance gas burner empowers you to cook with confidence. The Outdoor Artisan Pizza Oven by Kalamazoo offers a broad temperature range from 250° to 800°F for baking everything from calzones and deep-dish pizzas to ultra-thin Neapolitan-style pizzas with perfect, crispy crusts.

**Ready When You Are** The oven is designed to come up to temperature quickly. A pizza party can be a spontaneous event that doesn't require you to plan hours ahead like more traditional pizza ovens.

**Wood-Fired Flavor** Just because you have the convenience of gas doesn't mean giving up the flavor of a wood fire. The integrated wood tray delivers even more wood flavor than an open wood fire.

**No Installation Required** The countertop design makes the Outdoor Artisan Pizza Oven the perfect addition to new or existing outdoor kitchens, and it is available in both liquid propane and natural gas configurations. Simply connect the oven to your gas supply and you are ready to start a tradition of baking artisan pizza in your own backyard.



**Thick or thin crust, pan pizza or stuffed, even calzones or artisan bread... The Outdoor Artisan Pizza Oven helps you cook like a seasoned professional.**



“We have arrived at a time... when a person can bake the pizza of his dreams, the pizza he deserves, right in his own backyard.”

— Richard Nally, *Forbes Life*



# Kalamazoo Free-Standing Grills

In addition to the built-in grills that are part of the Kalamazoo Custom Outdoor Kitchen Collection, we offer a line of superior free-standing grills. The Kalamazoo Contemporary Series offers great performance for the style-minded, while the Kalamazoo 450 Series and 900 Series deliver the all around cooking prowess that has made Kalamazoo famous. For an overview of the advantages of a Kalamazoo grill, see page 13.

## Kalamazoo Contemporary Series Grills

**Edo Grill** Taking its cues from Japanese design, architecture and cuisine, the Kalamazoo Edo Grill is a contemporary design with a sleek, simple form. When not in use, it could be mistaken for a beautiful outdoor table. Form meets function when the two lustrous, hand-textured stainless steel panels slide open to reveal the controls and the 432 square-inch grilling surface, also creating ample counter space to each side.

With Kalamazoo's proprietary 50,000 BTU cast stainless steel burner and two control zones, the Edo cooks as good as it looks. This is a serious grill for homeowners who are serious about style.

**Sculpture Grill** Each Kalamazoo Sculpture grill is hand-built and offers a unique combination of true grilling performance and graceful curves of hand-welded and hand-rubbed stainless steel. These grills are works of art that enhance any outdoor décor. You'll be complimented on its looks and on the wonderful food you're cooking up.

Like the Edo, the Sculpture delivers 50,000 BTUs with two control zones and a 432 square-inch cooking surface. Both are available with custom laser-cut cooking surfaces. Select your own combination of patterns optimized for cooking meat, fish and vegetables. We can even create solid surface areas for Teppanyaki-style cooking and griddle work (see page 45).



**Kalamazoo Edo Grill**



**Kalamazoo Sculpture Grill**

"...there is no such thing as too much power."

— Allen Salkin, *New York Times*

# Kalamazoo Hybrid Free-Standing Grills



## **Kalamazoo 900HS Hybrid Free-Standing Grill with Side Burner K900HS**

154,000 BTUs total cooking power

84" wide

### **Cook with Charcoal, Wood and Gas**

Kalamazoo invented hybrid grilling technology, and to this day there is no other grill that so seamlessly combines the capabilities of a gas grill and a charcoal grill. Kalamazoo Dragon Burners deliver over 115 BTUs of grilling power to each square inch of the primary grilling area, so these are seriously capable gas grills. Above the burners are the Hybrid Grilling Drawers. For gas grilling, insert the ceramic-lined drawers to perfectly diffuse the heat. For charcoal and wood grilling, insert the wood rack drawers. The burners can be used to quickly and easily start the fire and then turned off, or they can be used throughout cooking to provide the heat while a handful of wood chunks lend all the flavor of an open wood fire.

For an overview of what makes a Kalamazoo grill unique, see page 13. For built-in grill specifications, see page 14.

*Cooks with any combination of charcoal, wood and gas*

*432 square-inch (450 Series) or 864 square-inch (900 Series) primary grilling area*

*50,000 main burner BTUs (450 Series) or 100,000 main burner BTUs (900 Series) in 2 or 4 control zones*

*Infrared rotisserie cradle systems with 11,000 BTUs (450 Series) or 22,000 BTUs (900 Series) in 1 or 2 control zones*

*Hassle-free cleanout system*

*Optional custom laser-cut stainless steel cooking surfaces (see page 45)*

*Available with wok-ready side burner*

*Offset smoker box available (see page 45)*

*Liquid propane standard, optional natural gas configuration*

*Hand-built in 304 stainless steel on a fully-welded frame*

*Accessory slot system for sauce racks, waste bins and more (see page 45)*



## **Kalamazoo 900HT Hybrid Free-Standing Grill**

**K900HT**

122,000 BTUs total cooking power

78" wide



## **Kalamazoo 450HT Hybrid Free-Standing Grill**

**K450HT**

61,000 BTUs total cooking power

63" wide



## **Kalamazoo 450HS Hybrid Free-Standing Grill with Side Burner**

**K450HS**

93,000 BTUs total cooking power

68" wide

# Kalamazoo Gas Free-Standing Grills

## Superior Firepower

The Kalamazoo advanced cooking concept creates a grill that excels at every outdoor cooking technique: grilling, roasting, searing, smoking, baking and rotisserie, especially with the optional offset smoker box and wok-ready side burner.

Personalize your grill with custom laser-cut cooking surface combining your choice of patterns optimized for different types of food (see page 45).

For an overview of what makes a Kalamazoo grill unique, see page 13. For built-in grill specifications, see page 14.

### Superior gas grill cooking performance

432 square-inch (450 Series) or 864 square-inch (900 Series) primary grilling area

50,000 main burner BTUs (450 Series) or 100,000 main burner BTUs (900 Series) in 2 or 4 control zones

Infrared rotisserie cradle systems with 11,000 BTUs (450 Series) or 22,000 BTUs (900 Series) in 1 or 2 control zones

Hassle-free cleanout system

Optional custom laser-cut stainless steel cooking surfaces (see page 45)

Available with wok-ready side burner

Available with 22,000 BTU infrared searing burner (K900G models only)

Offset smoker box available (see page 45)

Liquid propane standard, optional natural gas configuration

Hand-built in 304 stainless steel on a fully-welded frame

Accessory slot system for sauce racks, waste bins and more (see page 45)



### Kalamazoo 900GT Gas Free-Standing Grill K900GT

144,000 BTUs total cooking power  
22,000 BTU infrared searing burner  
78" wide



### Kalamazoo 900GS Gas Free-Standing Grill with Side Burner K900GS

176,000 BTUs total cooking power  
22,000 BTU infrared searing burner  
84" wide



### Kalamazoo 450GT Gas Free-Standing Grill K450GT

61,000 BTUs total cooking power  
63" wide



### Kalamazoo 450GS Gas Free-Standing Grill with Side Burner K450GS

93,000 BTUs total cooking power  
68" wide



# Kalamazoo Grill Accessories

We offer a wide assortment of unique grill accessories that help make outdoor cooking an even better experience. What else would you expect from the pioneers who invented the hybrid grill?

**Custom Cooking Surfaces** Laser cut from solid slabs of stainless steel up to 1/4" thick, Kalamazoo's custom cooking surfaces combine patterns specially developed for the best performance with different types of food and styles of cooking. Create any combination of these patterns and further customize with initials, logo or other artwork (see the photo at left). The sheer mass of these robust surfaces helps ensure great grill marks every time. Solid surface areas are also available for Teppanyaki-style cooking.



**Slot System Accessories** Add the convenience of a sauce rack, champagne bucket, waste basket (see the photo top-right) or utensil rack to your free-standing Kalamazoo grill. Slot system accessories can be arranged in a variety of ways. They also can be used on the insides of the doors of Kalamazoo weather-tight outdoor kitchen cabinets.

**Traditional Offset Smoker Box** While you can easily smoke-roast foods on any Kalamazoo grill, the cooking techniques for traditional American barbecue become much easier with our optional offset smoker box (see the photo bottom-right). The smoker box can be added to any Kalamazoo 450 or 900 Series free-standing grill at our factory. Food is cooked in the main grilling area while smoke is directed into the chamber from the offset smoker box. Baffles control the amount of smoke and can be used to snuff the fire. Assorted trays and electric starter included.

**Cooktop Griddle** Specially designed and fabricated for Kalamazoo wok-ready side burners, this heavy stainless steel griddle is perfect for fajitas and stir-fry.

**Sunbrella Grill Covers** A Kalamazoo is built to withstand the elements, but covering the grill helps it stay clean and always at the ready. And since a Kalamazoo deserves to be covered by nothing but the best, we make all our covers from black Sunbrella™ fabric, silk-screened with the Kalamazoo logo.



"The Kalamazoo... delivers the kind of performance I normally find only in restaurant kitchens."

— Chef Michael Chiarello



# 180° Martini Bar

Inspired by the vintage art deco architecture of Miami, and by the shape of the classic martini glass, the 180° Martini Bar raises outdoor entertaining to new heights and transforms your patio into a gathering place like no other.

**Beauty and Function Meet** Every 180° Martini Bar is handcrafted by talented, fourth generation stainless steel fabricators of hand-polished stainless steel as a one-of-a-kind work of functional art. Easily seat and entertain 8 people at a time at this fully-functioning wet bar. Features normally reserved for professional bars are at your disposal and within easy reach.

*16-gauge 304 (food-grade) stainless steel - made to last a lifetime*

*Bar faucet and stainless steel bar sink*

*Ample dual storage shelves*

*Large stainless steel ice bucket*

*Bottle opener with cap catcher*

*Integral speed rail stemware rack & condiment holder*

*Water supply and drain connections*

*In-line water purifier*

*GFCI (outdoor) outlets with 8' power cord*

*Outdoor-rated ambient LED lighting, inside the bar and out*

For the ultimate entertaining station, add refrigeration to the 180° Martini Bar. Behind the bar, create a counter with a Kalamazoo outdoor wine chiller, keg tapper, clear ice maker and freezer with martini glass chiller racks underneath.

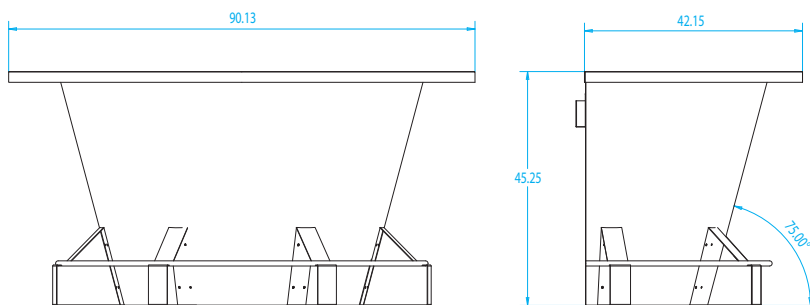

**Caterers and hotels serve hundreds of guests from this beautiful work of functional art.**

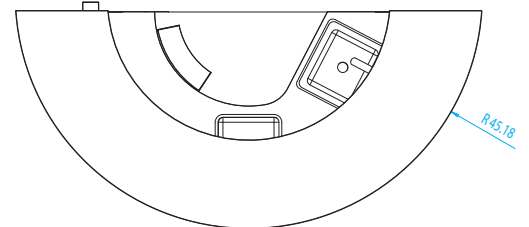

“...sure to make any gathering swanky.”

— Beautiful Homes



# Outdoor Kitchen Design Competition

Kalamazoo Outdoor Gourmet is a proud sponsor of the first and only nation-wide award focused on recognizing excellence in outdoor kitchen design. The Oasis Award is a great opportunity for outdoor kitchen design professionals to gain exposure and recognition for their business, with the winner featured in *Garden Design* magazine each year.

Demand for outdoor kitchens is exploding. According to a recent survey by the American Society of Landscape Architects, outdoor kitchens are among the most popular spaces being designed for residential clients. "Homeowners are requesting... complete outdoor rooms, such as kitchens and bars, for entertaining."

According to the National Kitchen and Bath Association, architects are seeing a 64% increase in outdoor kitchen requests as compared to 47% in 2005, and a recent outdoor living report by Standpoint Marketing Research, 1.2 million new households will install an outdoor kitchen in the next year.

In keeping with this growing trend, *Garden Design* magazine and Kalamazoo Outdoor Gourmet have joined forces to present the Oasis Award, recognizing excellence in outdoor kitchen design.

**Entries for the third annual competition are due August 3, 2009. For details, visit [www.OasisAward.com](http://www.OasisAward.com)**



"Consumers crave an outdoor kitchen and living area on par with the stylish and function-packed kitchens they have come to enjoy indoors."

— Kitchen & Bath Design News

# The Kalamazoo Experience



Here at Kalamazoo Outdoor Gourmet, we enjoy nothing more than sharing our passion for outdoor cooking and entertaining with our customers. Feel free to call or email us any time with your outdoor cooking and entertaining questions. Our monthly newsletter, *Hot Off the Grill*, features recipes for the grill, martini bar and pizza oven as well as tips and techniques to make every party or outdoor cooking session a total success. Subscribe today at [www.KalamazooGourmet.com](http://www.KalamazooGourmet.com).

ABOVE: Barbecue Shrimp Skewers with Peach Salsa from Hot Off the Grill

---

## Join Our Professional Partner Program

The Kalamazoo Outdoor Gourmet Professional Partner Program includes the best outdoor kitchen design professionals from across the country. By joining, professionals can have their work included in the online gallery at [www.KalamazooGourmet.com](http://www.KalamazooGourmet.com).

Professional Partners who complete our training program can also become *Certified Kalamazoo Outdoor Kitchen Designers*. Certified designers are included in the online Professional Partner Locator, used by homeowners across the country to find qualified designers and other outdoor kitchen professionals for their outdoor kitchen projects.

Call us at 1.800.868.1699 to learn more about the Kalamazoo Professional Partner Program.

**Don't miss out on new product launches and important product information updates. Make sure you receive future versions of the *Outdoor Kitchen Resource Book* by calling or email [partners@KalamazooGourmet.com](mailto:partners@KalamazooGourmet.com).**



1.800.868.1699  
[www.KalamazooGourmet.com](http://www.KalamazooGourmet.com)

Kalamazoo Outdoor Gourmet is always working to make the best outdoor cooking and entertaining equipment even better. Product specifications are subject to change without notice. For the latest product information, visit our website.