

**ELECTRIC COOKTOPS**



## INSTALLATION INSTRUCTIONS

**WOLF**<sup>®</sup>



## CONTACT INFORMATION

**Wolf Customer  
Service:**  
800-332-9513

**Website:**  
wolfappliance.com

As you follow these instructions, you will notice **WARNING** and **CAUTION** symbols. This blocked information is important for the safe and efficient installation of Wolf equipment. There are two types of potential hazards that may occur during installation.

### **⚠ CAUTION**

signals a situation where minor injury or product damage may occur if you do not follow instructions.

### **⚠ WARNING**

states a hazard that may cause serious injury or death if precautions are not followed.

Another footnote we would like to identify is **IMPORTANT NOTE**: This highlights information that is especially relevant to a problem-free installation.



**INSTALLATION** REQUIREMENTS

**IMPORTANT NOTE:** Save these Installation Instructions for the local inspector's use.

- Please read the entire Installation Instructions prior to installation.
- This installation must be completed by a qualified technician.
- **Installer:** please retain these instructions for local inspector's reference, then leave them with the homeowner.
- **Homeowner:** please read and keep these instructions for future reference and be sure to read the entire Use & Care Information prior to use.

**IMPORTANT NOTE:** This appliance must be installed in accordance with National Electrical Codes, as well as all state, municipal and local codes. The correct voltage, frequency and amperage must be supplied to the appliance from a dedicated, grounded circuit which is protected by a properly sized circuit breaker or time delay fuse. The proper voltage, frequency, and power ratings are listed on the product rating plate.

Record the model and serial numbers before installing the cooktop. Both numbers are on the rating plate, located on the underside of the cooktop. Refer to the illustration below.

**BEFORE YOU START**

- Proper installation is your responsibility. Have a qualified technician install this cooktop. You must also assure that electrical installation is adequate and in compliance with all local codes and ordinances.
- Installations and repairs must be performed by a qualified or licensed contractor or electrician qualified or licensed by the state, province, or region where this appliance is being installed.
- Make sure you have everything necessary for correct installation. It is the responsibility of the installer to comply with the installation clearances specified in this book and on the product rating plate. The rating plate is located on the underside of the cooktop. Refer to the illustration below.
- Electrical ground is required; see Electrical Requirements on page 14.
- Warranty service must be preformed by a Wolf authorized service center.

**⚠ WARNING**  
**This cooktop is intended for indoor use.**

RATING PLATE INFORMATION

**Model Number**

---

**Serial Number**

---

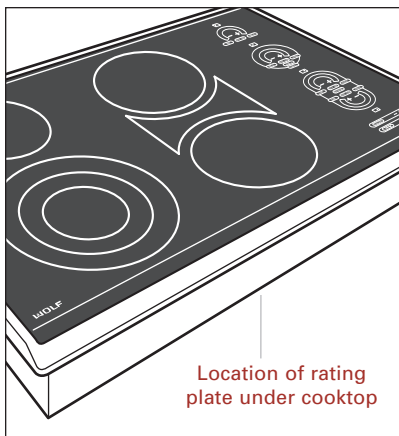

**Rating plate location**



**SITE PREPARATION**

**IMPORTANT NOTE:** Installation of the Wolf electric cooktop must meet the following location requirements. All dimensions listed are minimum requirements for safe operation. Refer to the illustration below.

**⚠ WARNING**

To eliminate the risk of burns or fire by reaching over heated surface units, cabinet storage space located above the surface units should be avoided. If cabinet storage is to be provided, the risk can be reduced by installing a ventilation hood that projects horizontally a minimum of 5" (127) beyond the bottom cabinets.

**LOCATION IN COUNTERTOP**

- A)** Minimum flat countertop surface. Must be equal to or greater than cooktop width.
- B)** Minimum 1" (25) wide clearance from the cooktop side edge to any combustible surface up to 18" (457) above the cooktop (noted by shaded area).

**OVERHEAD CABINET DIMENSIONS**

- C)** Minimum spacing between overhead side cabinets must be greater than or equal to the nominal width of the cooktop unit(s).
- D)** Minimum 18" (457) vertical distance from the countertop to the bottom of side cabinets within minimum side clearance.
- E)** Minimum vertical distance between the countertop and combustible materials above the cooktop must be 30" (762).
- F)** Minimum 1" (25) from rear wall.
- G)** Maximum 13" (330) depth of overhead and side cabinets directly above and within side clearance.

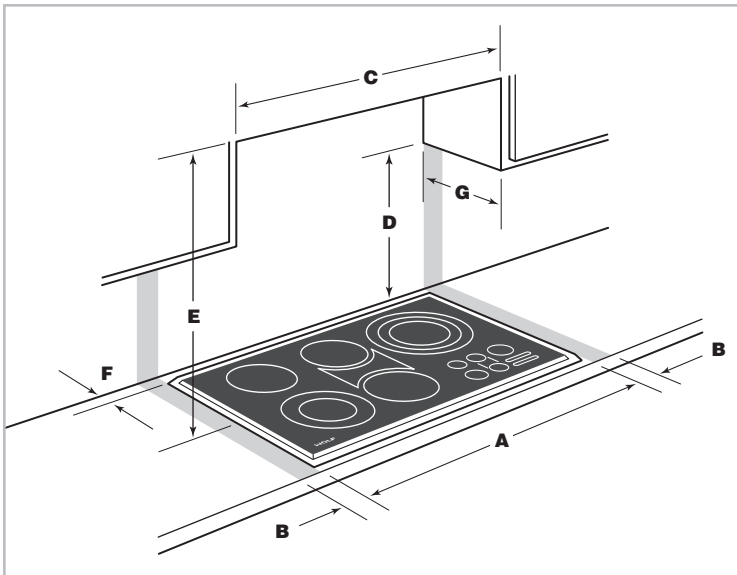

**Minimum clearances for installation**

**⚠ WARNING**

Failure to locate the cooktop unit without the proper clearances will result in a fire hazard.



INSTALLATION SPECIFICATIONS

The illustrations on pages 6–11 provide the overall dimensions, installation specifications and countertop cut-out for each of the Wolf electric cooktop models.

These cooktops are designed to fit a standard 24" (610) deep base cabinet with a 25" (635) deep countertop. Before making the countertop cut-out, verify that the cooktop will clear the side walls of the base cabinet below.

Clearance is required for the conduit located at the right rear of the cooktop. Refer to the illustration below for dimensions.

FRAMED ELECTRIC COOKTOPS

For framed models, a minimum 5<sup>3</sup>/<sub>4</sub>" (146) clearance is required between the countertop and any combustible surface directly below the cooktop.

Wolf framed electric cooktops are designed to be installed in combination with other cooktop units.

**IMPORTANT NOTE:** When multiple cooktop units are installed side by side, refer to the countertop cut-out dimensions on page 9.

Wolf framed electric cooktops can accommodate a Wolf downdraft ventilation system. Refer to installation instructions provided with the downdraft for additional specifications.

UNFRAMED ELECTRIC COOKTOPS

For unframed models, a minimum 6<sup>1</sup>/<sub>4</sub>" (159) clearance is required between the countertop and any combustible surface directly below the cooktop.

**IMPORTANT NOTE:** Unframed electric cooktops are not designed to be installed in combination with other cooktops.

**IMPORTANT NOTE:** Unframed electric cooktops cannot be installed with a downdraft ventilation system.

For installation options of the unframed electric cooktops, refer to Unframed Installations on pages 12–13.

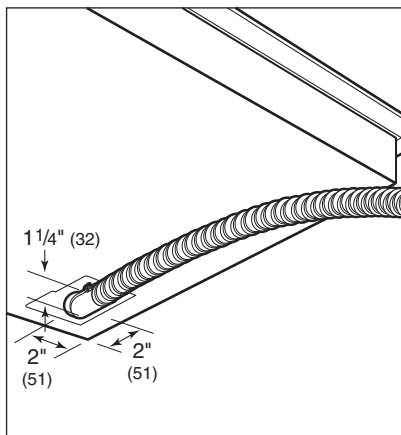

Conduit dimensions

Dimensions in parentheses are in millimeters unless otherwise specified.



FRAMED **MODEL CT15E**

The illustrations below provide installation specifications for Model CT15E.

If Model CT15E is installed above cabinets, the electrical placement is not critical. A grounded electrical box should be located within 4' (1.2 m) of the right rear of the cooktop.

For installation above an oven, unless you are using cabinets deeper than 24" (610), it is recommended that the electrical supply be placed in the base cabinet to the right of the oven.

**IMPORTANT NOTE:** Do not block the cooling fan located at the bottom of the cooktop.

INSTALLATION SPECIFICATIONS – MODEL CT15E

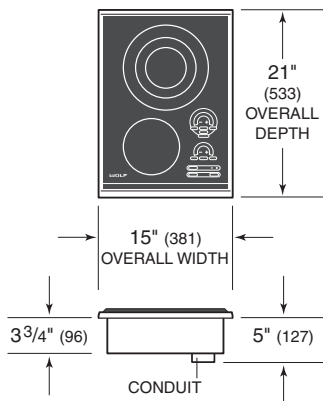

**Overall Dimensions**

**MODEL CT15E**

Overall Width	15" (381)
Overall Height	3 3/4" (96)
Overall Depth	21" (533)
Minimum Cabinet Depth	22 3/4" (578)
Minimum Height Clearance*	4" (102)
Cut-Out Width	13 3/8" (340)
Cut-Out Depth	19 1/4" (489)

\*Minimum 5 3/4" (146) clearance is required between countertop and any combustible surface directly below the cooktop.

For detailed conduit dimensions, refer to the illustration on page 5.

Dimensions may vary to ± 1/8" (3).

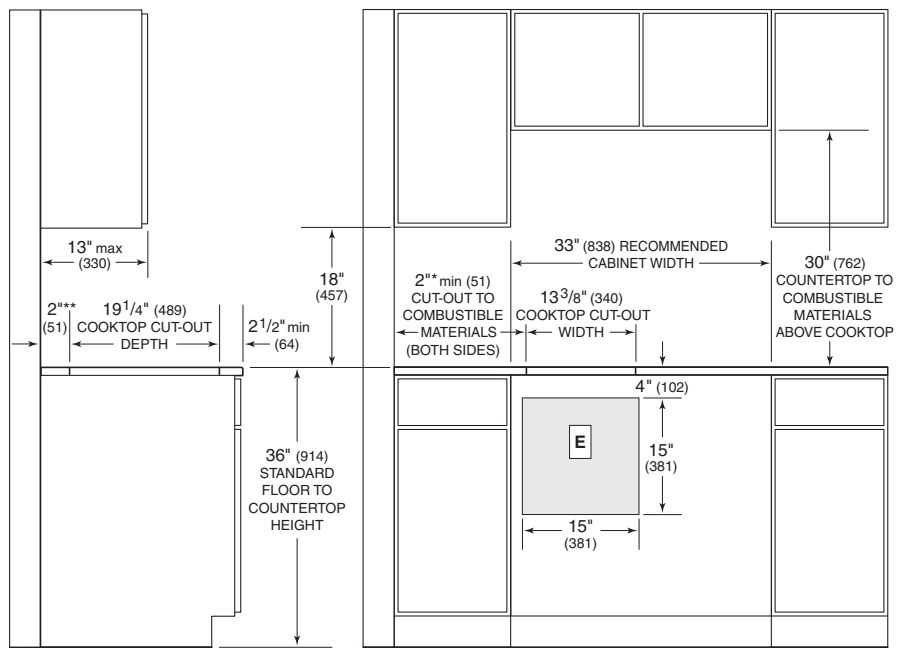

NOTE: Application shown allows for installation of two 15" (381) modules side-by-side with 33" (838) recommended cabinet width. 18" (457) recommended cabinet width for installation of single 15" (381) cooktop or module. \*Minimum clearance from both side edges of cooktop cut-out to combustible materials up to 18" (457) above countertop. \*\*Minimum clearance from rear edge of cooktop cut-out to combustible materials up to 18" (457) above countertop.

**Countertop Cut-Out**

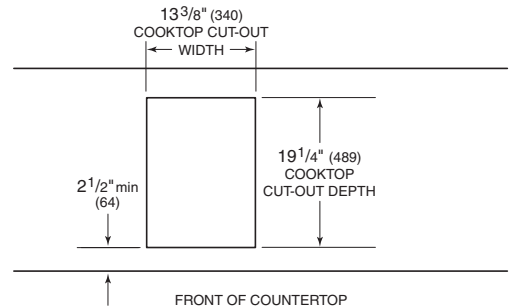



FRAMED **MODEL CT30E**

The illustrations below provide installation specifications for Model CT30E.

For ease of installation, 33" (838) cabinets are recommended for installation of Model CT30E.

A Wolf 30" (762) or 36" (914) built-in single oven may be installed below Model CT30E. For this installation, unless you are using cabinets deeper than 24" (610), it is recommended that the electrical supply be placed in the base cabinet to the right of the oven.

Refer to installation instructions provided with the built-in oven for additional specifications.

If Model CT30E is installed above cabinets, the electrical placement is not critical. A grounded electrical box should be located within 4' (1.2 m) of the right rear of the cooktop.

**IMPORTANT NOTE:** Do not block the cooling fan located at the bottom of the cooktop.

**IMPORTANT NOTE:** Installation specifications for Model CT30E-208/S are identical to Model CT30E. Only the electrical specifications differ.

INSTALLATION SPECIFICATIONS – MODEL CT30E

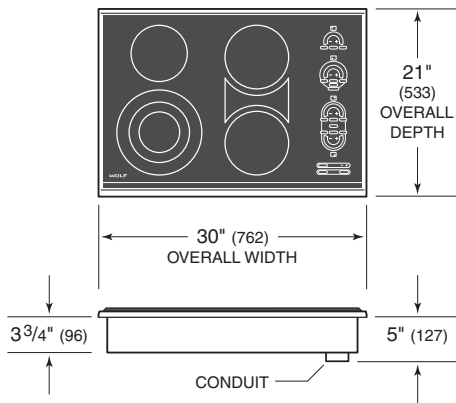

**Overall Dimensions**

**MODEL CT30E**

Overall Width	30" (762)
Overall Height	3 3/4" (96)
Overall Depth	21" (533)
Minimum Cabinet Depth	22 3/4" (578)
Minimum Height Clearance*	4" (102)
Cut-Out Width	28 3/8" (721)
Cut-Out Depth	19 1/4" (489)

\*Minimum 5 3/4" (146) clearance is required between countertop and any combustible surface directly below the cooktop.

For detailed conduit dimensions, refer to the illustration on page 5.

Dimensions may vary to ± 1/8" (3).

Dimensions in parentheses are in millimeters unless otherwise specified.

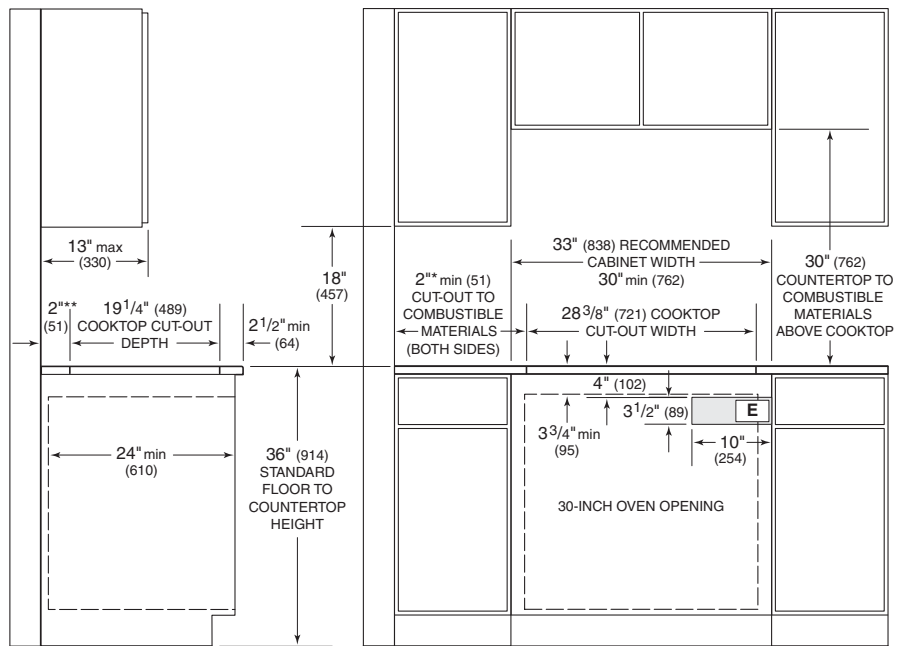

\*Minimum clearance from both side edges of cooktop cut-out to combustible materials up to 18" (457) above countertop. \*\*Minimum clearance from rear edge of cooktop cut-out to combustible materials up to 18" (457) above countertop.

**Countertop Cut-Out**

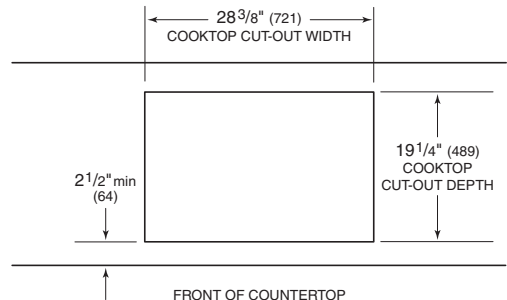



FRAMED **MODEL CT36E**

The illustrations below provide installation specifications for Model CT36E.

For ease of installation, 39" (991) cabinets are recommended for installation of Model CT36E.

A Wolf 30" (762) or 36" (914) built-in single oven may be installed below Model CT36E. For this installation, unless you are using cabinets deeper than 24" (610), it is recommended that the electrical supply be placed in the base cabinet to the right of the oven.

Refer to installation instructions provided with the built-in oven for additional specifications.

If Model CT36E is installed above cabinets, the electrical placement is not critical. A grounded electrical box should be located within 4' (1.2 m) of the right rear of the cooktop.

**IMPORTANT NOTE:** Do not block the cooling fan located at the bottom of the cooktop.

INSTALLATION SPECIFICATIONS – MODEL CT36E

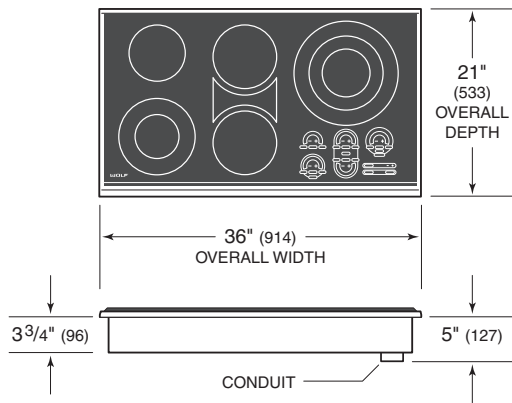

**Overall Dimensions**

**MODEL CT36E**

Overall Width	36" (914)
Overall Height	3 3/4" (96)
Overall Depth	21" (533)
Minimum Cabinet Depth	22 3/4" (578)
Minimum Height Clearance*	4" (102)
Cut-Out Width	34 3/8" (873)
Cut-Out Depth	19 1/4" (489)

\*Minimum 5 3/4" (146) clearance is required between countertop and any combustible surface directly below the cooktop.

For detailed conduit dimensions, refer to the illustration on page 5.

Dimensions may vary to ± 1/8" (3).

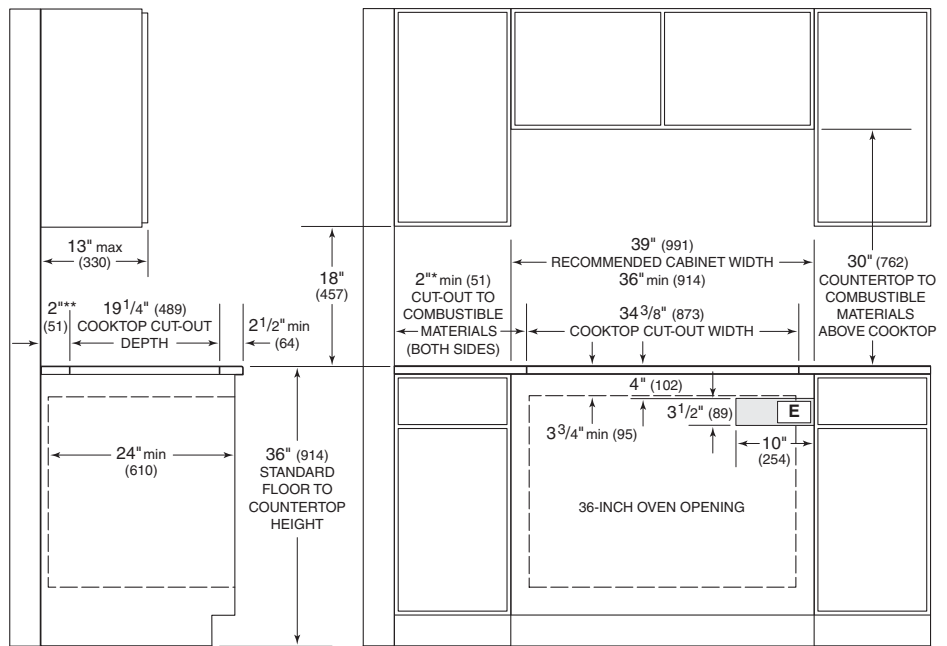

\*Minimum clearance from both side edges of cooktop cut-out to combustible materials up to 18" (457) above countertop. \*\*Minimum clearance from rear edge of cooktop cut-out to combustible materials up to 18" (457) above countertop.

**Countertop Cut-Out**

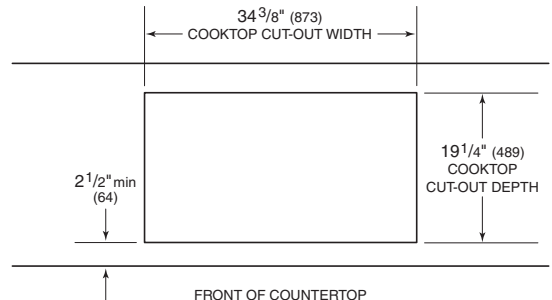





**MULTIPLE COOKTOP** INSTALLATION

If the framed electric cooktop is to be used with any combination of additional cooktop units or modules with a filler strip, the cut-out width is calculated by adding the corresponding units' cut-out dimensions plus 1 1/4" (32) for each additional unit. Refer to the illustration below.

**IMPORTANT NOTE:** For Model CT15E, the cut-out width should be increased from 13 3/8" (340) to 14" (356) when installed with multiple units.

**IMPORTANT NOTE:** Unframed electric cooktops Models CT30EU and CT36EU are not designed to be installed in combination with other cooktop units.

**IMPORTANT NOTE:** When multiple units are installed side by side, each unit must have its own separate recommended electrical circuit.

When two or more modules are installed together, an integrated module filler strip (#802726) is recommended. If a 30" (762) downdraft ventilation system is also installed, an integrated module support for downdraft ventilation (#803386) is also required. Contact your Wolf dealer for information on these accessory components.

ACCESSORIES

Optional accessories are available through your Wolf dealer. To obtain local dealer information, visit the Showroom Locator section of our website, [wolfappliance.com](http://wolfappliance.com).

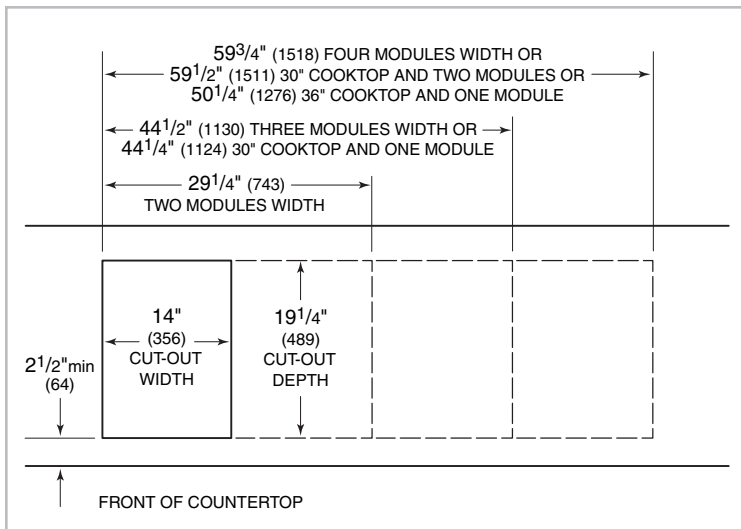

**Countertop cut-out dimensions for installation of multiple cooktops**

Dimensions in parentheses are in millimeters unless otherwise specified.



UNFRAMED **MODEL CT30EU**

The illustrations below provide installation specifications for Model CT30EU.

For ease of installation, 33" (838) cabinets are recommended for installation of Model CT30EU.

A Wolf 30" (762) built-in single oven may be installed below Model CT30EU. For this installation, unless you are using cabinets deeper than 24" (610), it is recommended that the electrical supply be placed in the base cabinet to the right of the oven. Refer to installation instructions provided with the built-in oven for additional specifications.

If Model CT30EU is installed above cabinets, electrical placement is not critical. A grounded electrical box should be located within 4' (1.2 m) of the right rear of the cooktop.

For Model CT30EU installation options, refer to Unframed Installations on pages 12–13.

**IMPORTANT NOTE:** For flush mount applications, it is recommended to measure the cooktop glass before cutting the countertop to ensure a proper fit. Small variances may exist between the template and the cooktop.

**INSTALLATION SPECIFICATIONS – MODEL CT30EU**

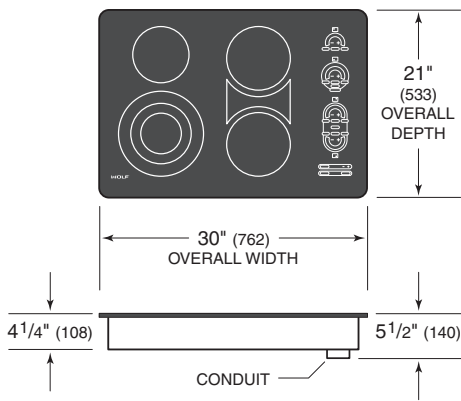

**Overall Dimensions**

**MODEL CT30EU**

Overall Width	30" (762)
Overall Height	4 1/4" (108)
Overall Depth	21" (533)
Minimum Cabinet Depth	22 3/4" (578)
Minimum Height Clearance*	4 1/2" (114)
Cut-Out Width	28 3/8" (721)
Cut-Out Depth	19 3/8" (492)

\*Minimum 6 1/4" (159) clearance is required between countertop and any combustible surface directly below the cooktop.

For detailed conduit dimensions, refer to the illustration on page 5.

Dimensions may vary to ± 1/8" (3).

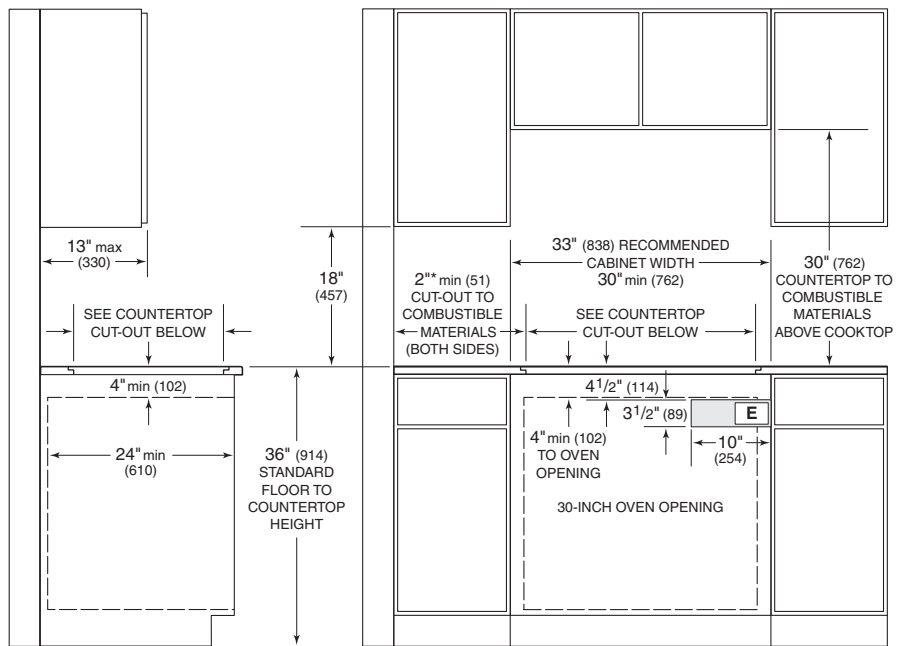

\*Minimum clearance from both side edges and back edge of cooktop cut-out to combustible materials up to 18" (457) above countertop.

**Countertop Cut-Out**

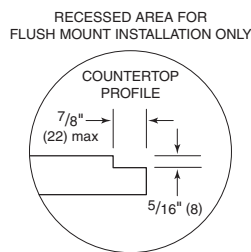

\*\*Minimum dimension, but may be exceeded by up to 1/8" (3).

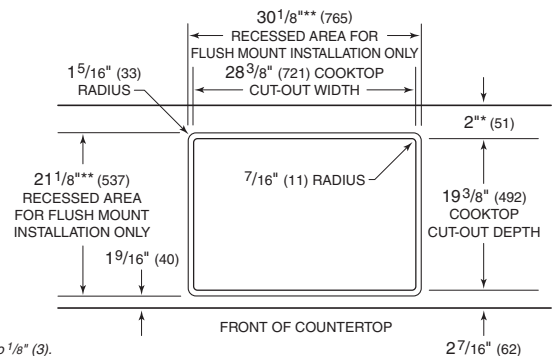



UNFRAMED **MODEL CT36EU**

The illustrations below provide installation specifications for Model CT36EU.

For ease of installation, 39" (991) cabinets are recommended for installation of Model CT36EU.

A Wolf 36" (914) built-in single oven may be installed below Model CT36EU. For this installation, unless you are using cabinets deeper than 24" (610), it is recommended that the electrical supply be placed in the base cabinet to the right of the oven. Refer to installation instructions provided with the built-in oven for additional specifications.

If Model CT36EU is installed above cabinets, electrical placement is not critical. A grounded electrical box should be located within 4' (1.2 m) of the right rear of the cooktop.

For Model CT36EU installation options, refer to Unframed Installations on pages 12–13.

**IMPORTANT NOTE:** For flush mount applications, it is recommended to measure the cooktop glass before cutting the countertop to ensure a proper fit. Small variances may exist between the template and the cooktop.

INSTALLATION SPECIFICATIONS – MODEL CT36EU

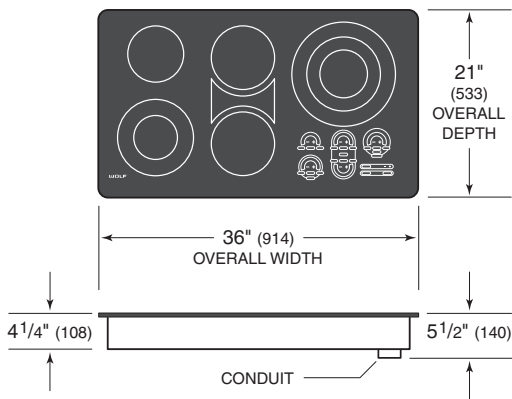

**Overall Dimensions**

**MODEL CT36EU**

Overall Width	36" (914)
Overall Height	4 1/4" (108)
Overall Depth	21" (533)
Minimum Cabinet Depth	22 3/4" (578)
Minimum Height Clearance*	4 1/2" (114)
Cut-Out Width	34 3/8" (873)
Cut-Out Depth	19 3/8" (492)

\*Minimum 6 1/4" (159) clearance is required between countertop and any combustible surface directly below the cooktop.

For detailed conduit dimensions, refer to the illustration on page 5.

Dimensions may vary to ± 1/8" (3).

Dimensions in parentheses are in millimeters unless otherwise specified.

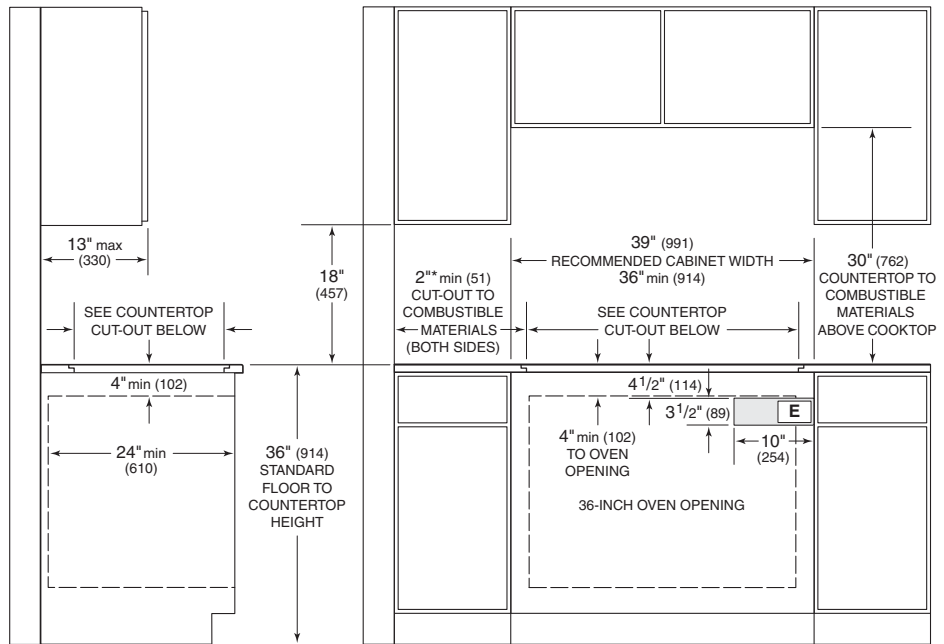

\*Minimum clearance from both side edges and back edge of cooktop cut-out to combustible materials up to 18" (457) above countertop.

**Countertop Cut-Out**

RECESSED AREA FOR FLUSH MOUNT INSTALLATION ONLY

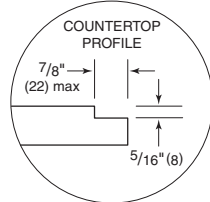

\*\*Minimum dimension, but may be exceeded by up to 1/8" (3).

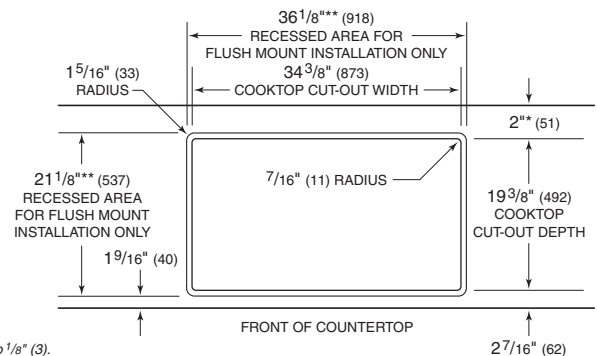

**UNFRAMED INSTALLATIONS****⚠ CAUTION**

**Flush mount installations are intended for granite, solid surface or stone countertop surfaces only. Failure to use high heat resistant surface will result in countertop damage if hot cooking utensils are accidentally moved off the cooking surface.**

**MODELS CT30EU AND CT36EU**

Unframed electric cooktop Models CT30EU and CT36EU can be mounted flush with the top of the countertop or as a frameless installation with the glass mounted on top of the countertop surface.

**IMPORTANT NOTE:** The materials required for a flush mount installation are provided with the unframed Models CT30EU and CT36EU. Refer to the instructions provided with the unframed cooktop installation kit (#811358) for additional specifications.

**FLUSH MOUNT INSTALLATION**

There are two options for a flush mount installation of the unframed electric cooktop; Option 1 and Option 2.

**OPTION 1:** For this flush mount installation, a recessed area surrounding the standard countertop cut-out is required. Fabrication of the recessed area must take place before the final countertop installation. A template of the countertop cut-out is provided with the unframed cooktop for fabrication purposes.

**IMPORTANT NOTE:** This fabrication method is not recommended for molded backsplash style countertops (triple cove).

For countertop cut-out dimensions, refer to the Installation Specifications illustration on page 10 for Model CT30EU and page 11 for Model CT36EU.

In order to rout the required recessed area for this flush mount installation, a second template must be made from  $\frac{1}{2}$ " (13) plywood. The template will be used as a guide for a top bearing router bit.

Make the wood template wide enough so that clamps used to hold this template to the countertop do not interfere with the router base. The cut-out dimension of the wood template should match the outer perimeter of the template supplied with the cooktop.

Center the wood template over the existing cut-out in the countertop and clamp. It may be helpful to use medium-strength double-sided tape to adhere the template to the countertop; this will keep the template from shifting during the routing operation. Make sure that the adhesive can be easily removed by testing it on a scrap piece of the countertop. Using a top bearing router bit with the wood template as a guide, rout out a  $\frac{5}{16}$ " (8) deep recessed area in the countertop cut-out.

Dimensions in parentheses are in millimeters unless otherwise specified.



UNFRAMED INSTALLATIONS

FLUSH MOUNT INSTALLATION

**OPTION 2:** For this flush mount installation, the countertop cut-out will be the same size as the outer edge of the glass top. It is recommended that cooktop itself be used as the template for the cut-out. Turn the cooktop over and mark the opening using the glass top as a template.

It will be necessary to attach L-shaped brackets or cleats to the inner perimeter of the cut-out to support the cooktop. The top edge of the bracket can be no wider than  $\frac{7}{8}$ " (22) and will be attached  $\frac{5}{16}$ " (8) below the surface of the countertop. Refer to the illustration below. Attachment of the brackets is up to the installer's discretion, wherever enough countertop material is present.

For additional support in the cut-out area, adhere scrap countertop material to the bottom side of the countertop. Consult your countertop supplier for the proper methods of attachment.

FRAMELESS INSTALLATION

Unframed electric cooktop Models CT30EU and CT36EU can be installed as a frameless application, with the glass mounted on top of the countertop surface. For countertop cut-out dimensions, refer to the Installation Specifications illustration on page 10 for Model CT30EU and page 11 for Model CT36EU.

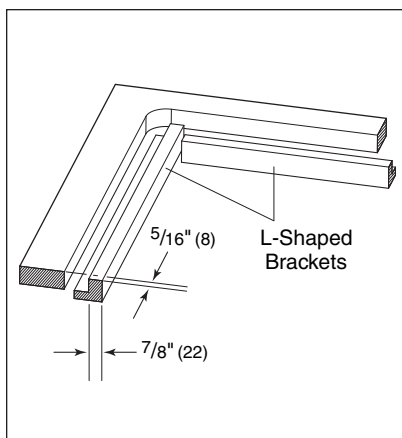

Flush mount installation brackets

**ELECTRICAL REQUIREMENTS****⚠ WARNING**

**Verify that power is disconnected from the electrical box before proceeding.**

**REQUIRED POWER SUPPLY**

- **Model CT15E**  
240 V AC / 60 Hz / 20 amp service  
208 V AC / 60 Hz / 15 amp service
- **Models CT30E and CT30EU**  
240 V AC / 60 Hz / 40 amp service  
208 V AC / 60 Hz / 40 amp service
- **Model CT30E-208/S**  
208 V AC / 60 Hz / 40 amp service
- **Models CT36E and CT36EU**  
240 V AC / 60 Hz / 50 amp service  
208 V AC / 60 Hz / 40 amp service

**MAXIMUM CONNECTED LOAD**

- **Model CT15E**  
3.7 kW at 240 V AC  
2.8 kW at 208 V AC
- **Models CT30E and CT30EU**  
8.1 kW at 240 V AC  
6.1 kW at 208 V AC
- **Model CT30E-208/S**  
7.9 kW at 208 V AC
- **Models CT36E and CT36EU**  
10.5 kW at 240 V AC  
7.9 kW at 208 V AC

The Wolf electric cooktop requires a separate, grounded 3-wire service with its own circuit breaker. Locate the electrical supply within the shaded area shown in the Installation Specifications illustration for your specific model on pages 6–11.

This appliance must be installed in accordance with National Electrical Codes, as well as all state, municipal and local codes. The correct voltage, frequency and amperage must be supplied to the appliance from a dedicated, grounded circuit which is protected by a properly sized circuit breaker or time delay fuse. The proper voltage, frequency and power ratings are listed on the product rating plate, located on the underside of the cooktop. Refer to the illustration on page 3 for location of the rating plate.



**ELECTRICAL** REQUIREMENTS

**For Electrical Installation** – attach the conductors to the residence wiring in accordance with National Electrical Codes and all state, provincial, municipal and local codes.

**⚠ WARNING**

**The complete appliance must be properly grounded at all times when electrical power is applied.**

**Do not ground the appliance with the neutral (white) house supply wire. A separate ground wire must be utilized.**

**If aluminum house supply wiring is utilized, splice the appliance copper wire to the aluminum house wiring using special connectors designed and agency certified for joining copper and aluminum. Follow the connector manufacturer's recommended procedure carefully. Improper connection can result in a fire hazard!**

IMPORTANT  
NOTE

**This appliance must be installed in accordance with National Electrical Codes, as well as all state, municipal and local codes.**



COOKTOP **INSTALLATION**

Attach the foam strip to the underside of the cooktop frame. Refer to the illustration below.

**IMPORTANT NOTE:** For frameless installations, adhere the foam strip to the outer edge of the glass, not the support frame.

**IMPORTANT NOTE:** The materials required for a flush mount installation are provided with the unframed Models CT30EU and CT36EU. Refer to the instructions provided with the unframed cooktop installation kit (#811358).

Gently lower the unit into the cut-out area in the countertop and center. Check that the front edge of cooktop is parallel to the front edge of the countertop. Check that all required clearances are met.

Attach the brackets to the bottom of the unit, as shown in the illustration below. Install the clamping screws into the bracket and tighten until the screws contact the underside of the countertop. **Do not overtighten the screws.**

**IMPORTANT NOTE:** Do not seal the cooktop to the countertop. It must be removed if service is necessary.

**⚠ WARNING**

**If the ceramic glass top of the cooktop is broken, turn off power to the unit. Do not operate until glass has been replaced by a Wolf authorized service center.**

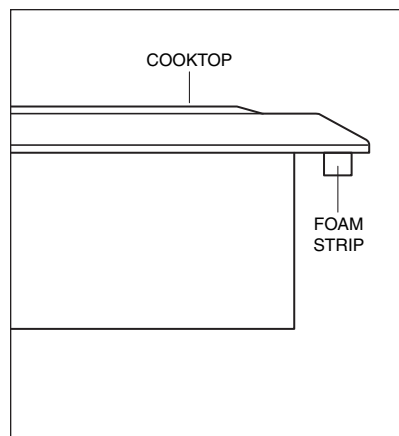

**Foam strip**

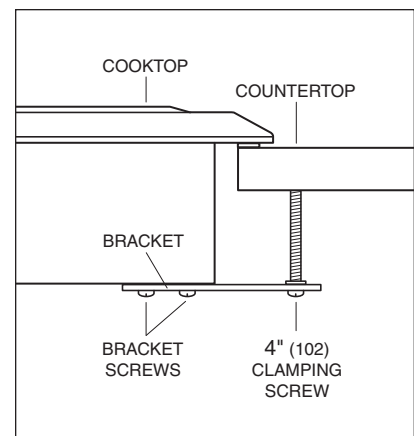

**Installation brackets**





### BEFORE **OPERATING** THE COOKTOP

Clean the ceramic glass surface carefully using the Cooktop Cleaning Crème provided with the cooktop. Remove all cleaning residue.

Read the entire Wolf Electric Cooktops Use & Care Information included with the cooktop. Important safety, service and warranty information is contained within the book.

### COOKTOP **REMOVAL**

**IMPORTANT NOTE:** This procedure should only be performed by a Wolf authorized service center.

If it is necessary to remove the cooktop for cleaning or service, disconnect the electrical supply. Remove the mounting brackets on the right and left side of the unit and remove the cooktop. Reinstall in the reverse order.

**IMPORTANT NOTE:** For flush mount installations, use a razor blade to carefully cut around the RTV perimeter seal. A new RTV installation kit (#811358) will be required to reinstall the cooktop. This kit is available through your Wolf dealer. To obtain local dealer information, visit the Showroom Locator section of our website, [wolfappliance.com](http://wolfappliance.com).

### ACCESSORIES

**Optional accessories are available through your Wolf dealer. To obtain local dealer information, visit the Showroom Locator section of our website, [wolfappliance.com](http://wolfappliance.com).**



## ACCESSORIES

Optional accessories are available through your Wolf dealer. To obtain local dealer information, visit the Showroom Locator section of our website, [wolfappliance.com](http://wolfappliance.com).

## VENTILATION OPTIONS

**IMPORTANT NOTE:** It is recommended that you operate the Wolf electric cooktop with either a Wolf cooktop ventilation hood, downdraft system or Pro ventilation hood. Contact your Wolf dealer for details.

- **Cooktop Wall Hood** – 30" (762) or 36" (914) widths in classic stainless steel.
- **Cooktop Island Hood** – 42" (1067) width in classic stainless steel.
- **Downdraft Ventilation System** – 30" (762), 36" (914) or 45" (1143) widths, with top cover and control panel in classic, platinum and carbon stainless steel finishes—45" (1143) downdraft available in classic finish only. Not for use with Model CT30EU or Model CT36EU.
- **Pro Wall Hood** – 22" (559), 24" (610) or 27" (686) depths and 30" (762) to 66" (1676) widths in classic stainless steel.
- **Pro Wall Chimney Hood** – 36" (914) to 54" (1372) widths in classic stainless steel.
- **Pro Island Hood** – 36" (914) to 66" (1676) widths in classic stainless steel.
- **Pro Hood Liner** – available in widths to accommodate 36" (914) to 60" (1524) hoods.

All hoods have welded seams, sealed halogen lighting and removable, dishwasher-safe filters.

Blower requirements may vary due to the length of ducting and number of angles. The basic recommendation is 1 CFM per 100 Btu/hr (1 kW equals 3,415 Btu/hr). Always consult your HVAC professional for more concise blower requirements.

**IMPORTANT NOTE:** When installing a ventilation hood, refer to the specific requirements of the hood for the minimum dimension to countertop.

## TROUBLESHOOTING

## IF COOKTOP DOES NOT OPERATE

**IMPORTANT NOTE:** If the electric cooktop does not operate properly, follow these troubleshooting steps:

- Verify that power is being supplied to the cooktop.
- Check electrical connections to ensure that the installation has been completed correctly.
- Follow troubleshooting procedures as described in the Wolf Electric Cooktops Use & Care Information.
- If the cooktop still does not work, contact a Wolf authorized service center. Do not attempt to repair the cooktop yourself. Wolf is not responsible for service required to correct a faulty installation.

**⚠ WARNING**

**This cooktop must be repaired only by a Wolf authorized service center. The unit must be disconnected from power prior to service.**



### IF YOU NEED SERVICE

- If service is necessary, maintain the quality built into your electric cooktop by calling a Wolf authorized service center.
- To obtain the name and number of a Wolf authorized service center, check the Contact & Support section of our website, **wolfappliance.com** or call Wolf Customer Service at **800-332-9513**.
- When calling for service, you will need the cooktop model and serial numbers. Both numbers are listed on the rating plate, located on the underside of the cooktop. Refer to the illustration on page 3 for location of the rating plate.

### CONTACT INFORMATION

**Wolf Customer Service:**  
**800-332-9513**

**Website:**  
**wolfappliance.com**

The information and images in this book are the copyright property of Wolf Appliance, Inc., an affiliate of Sub-Zero, Inc. Neither this book nor any information or images contained herein may be copied or used in whole or in part without the express written permission of Wolf Appliance, Inc., an affiliate of Sub-Zero, Inc.

©Wolf Appliance, Inc. all rights reserved.



WOLF APPLIANCE, INC. P.O. BOX 44848 MADISON, WI 53744 800-332-9513 WOLFAPPLIANCE.COM

**WOLF**<sup>®</sup>

812358

12/2007



812358\$RevA