

This Owner's Manual is provided and hosted by [Appliance Factory Parts](http://www.appliancefactoryparts.com).

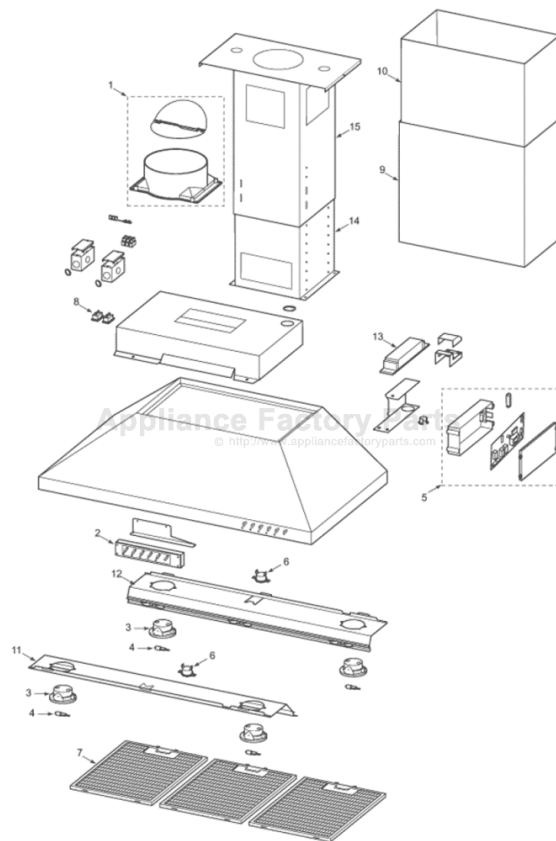

Wolf IH4227 Owner's Manual

[Shop genuine replacement parts for Wolf IH4227](#)



[Find Your Wolf HVAC Parts - Select From 108 Models](#)

----- Manual continues below -----

COOKTOP VENTILATION HOODS



USE & CARE INFORMATION

WOLF[®]



CONTENTS

Introducing Wolf Cooktop Ventilation Hoods	3
Safety Instructions & Precautions	4
Wolf Cooktop Ventilation Hood Features	6
Wolf Cooktop Ventilation Hood Use & Care	8
Wolf Cooktop Ventilation Hood Accessories	12
Troubleshooting Guide	13
Service Information	14
Wolf Warranty	15

As you read this Use & Care Information, take particular note of the **CAUTION** and **WARNING** symbols when they appear. This information is important for safe and efficient use of the Wolf equipment.

▲ CAUTION

signals a situation where minor injury or product damage may occur if you do not follow instructions.

▲ WARNING

states a hazard that may cause serious injury or death if precautions are not followed.

In addition, this Use & Care Information may signal an **IMPORTANT NOTE** which highlights information that is especially important.



THANK YOU

Your purchase of a Wolf cooktop ventilation hood attests to the importance you place upon the quality and performance of your cooking equipment. We understand this importance and have designed and built your ventilation hood with quality materials and workmanship to give you years of dependable service.

We know you are eager to start cooking, but before you do, please take some time to read this Use & Care Information. Whether you are a beginning cook or an expert chef, it will be to your benefit to familiarize yourself with the safety practices, features, operation and care recommendations of the Wolf cooktop ventilation hood.

We appreciate your choice of a Wolf Appliance product and welcome any suggestions or comments you may have. To share your opinions with us, please call 800-332-9513.

Your Wolf ventilation hood is protected by a warranty that is one of the finest in the industry. Take a moment to read the warranty statement on page 15 and refer to it should service become necessary.

CONTACT INFORMATION

Wolf Customer Service:
800-332-9513

Website:
wolfappliance.com

SAFETY INSTRUCTIONS AND PRECAUTIONS



WHAT TO DO

- **IMPORTANT NOTE: Read all instructions before using this appliance.**
- **Read this Use and Care Information carefully** before using your new ventilation unit to reduce the risk of fire, electrical shock or injury to persons.
- **Use this unit only in the manner intended by Wolf Appliance Company.** If you have questions, contact us at 800-332-9513.
- **Before servicing or cleaning unit, switch power off** at service panel and lock the service disconnecting means to prevent power from being switched on accidentally. When the service disconnecting means can not be locked, securely fasten a prominent warning device, such as a tag, to the service panel.
- **Installation work and electrical wiring must be done by qualified person(s)** in accordance with all applicable codes and standards, including fire-rated construction codes and standards.
- **Sufficient air is needed for proper combustion and exhausting of gases** through the flue (chimney) of fuel burning equipment to prevent back-drafting. Follow the heating equipment manufacturer's guideline and safety standards such as those published by the National Fire Protection Association (NFPA), the American Society for Heating, Refrigeration and Air Conditioning Engineers (ASHRAE) and the local code authorities.
- **Ducted fans must always be vented to the outdoors.**
- **To reduce the risk of fire, use only steel ductwork.**
- **This unit must be grounded.**
- **To avoid motor bearing damage** and noisy and/or unbalanced impellers, keep drywall spray, construction dust, etc. off power unit.
- **For maximum ventilation capability,** the bottom of the hood should be a minimum of 24" (610) and maximum of 30" (762) above the countertop.
- **Please read specification label** on product for further information and requirements.
- **Two installers are recommended** because of the large size and weight of this hood.
- **Your hood motor has a thermal overload which will automatically shut off the motor if it becomes overheated.** The motor will restart when it cools down. If the motor continually shuts off and restarts, contact an authorized Wolf service provider.
- **Do not use abrasive or caustic cleaners or detergents** on this appliance as these may cause permanent damage.

⚠ CAUTION

To reduce the risk of fire and properly exhaust air, be certain to duct air outside. Do not vent exhaust air into spaces within walls or ceilings or into attics, crawl spaces or garages.



WHAT NOT TO DO

- **When cutting or drilling into wall or ceiling, do not damage electrical wiring or other hidden utilities.**
- **To reduce the risk of fire or electric shock,** do not use this hood with an additional speed control device.
- **For general ventilating use only.** Do not use to exhaust hazardous or explosive materials and vapors.
- **Avoid using food products that produce flames** under the wall hood or island hood.

⚠ WARNING

TO REDUCE THE RISK OF INJURY TO PERSONS IN THE EVENT OF A GREASE FIRE, OBSERVE THE FOLLOWING:

Smother flames with a close-fitting lid, baking sheet or other metal tray, then turn off the gas burner. Be careful to prevent burns. If the flames do not go out immediately, evacuate and call the fire department.

Do not use water, including wet dish cloths or towels – a violent steam explosion will result.

Never pick up a flaming pan – you may be burned.

SAFETY PRECAUTIONS

TO REDUCE THE RISK OF A COOKTOP GREASE FIRE:

- **Never leave surface units unattended at high settings.** Boilovers cause smoking and greasy spillovers that may ignite. Heat oils slowly on low or medium settings.
- **Always turn hood ON when cooking at high heat** or when cooking flaming foods.
- **Clean ventilating fans frequently.** Grease should not be allowed to accumulate on fan or filter.
- **Use proper pan size.** Always use cookware appropriate for the size of the surface element.

USE AN EXTINGUISHER ONLY IF:

- **You know you have a Class ABC extinguisher** and you already know how to operate it.
- **The fire is small and contained** in the area where it started.
- **The fire department is being called.**
- **You can fight the fire with your back to an exit (NFPA Fire Safety Tips).**



COOKTOP WALL HOOD FEATURES

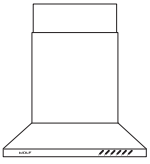

Model CTWH30

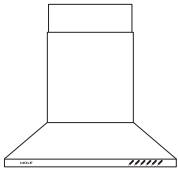

Model CTWH36

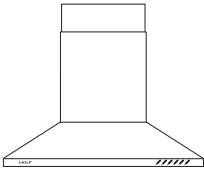

Model IH4227

- Classic stainless steel finish
- Internal or remote blower options
- Front-mounted controls with LED indicators
- Heavy-duty stainless steel seamless construction
- Three-speed blower control
- Variable-speed blowers
- Filter clean timer lets you know when the filter needs cleaning
- Delay-off mode automatically turns unit off
- Sealed halogen lighting with three settings
- Stainless steel filter cover with dishwasher safe aluminum mesh filter
- Heat sentry feature automatically turns unit on when heat is sensed and automatically adjusts blower speed
- Transition with backdraft damper included
- Fits 8' (2.4 m) to 9' (2.7 m) ceilings—flue extension to accommodate 10' (3 m) ceilings is available
- UL listed to US and Canadian safety standards
- Two and five year residential warranty – exclusions apply, see warranty on page 15

IMPORTANT NOTE: Wolf cooktop wall hoods are recommended for use with Wolf electric and gas cooktops and integrated modules. They are NOT recommended for use with Wolf dual fuel ranges, gas ranges and rangetops. Any violation of this application may void your warranty for one or both products.

MODEL CTWH30
30" (762) Cooktop Wall Hood

MODEL CTWH36
36" (914) Cooktop Wall Hood

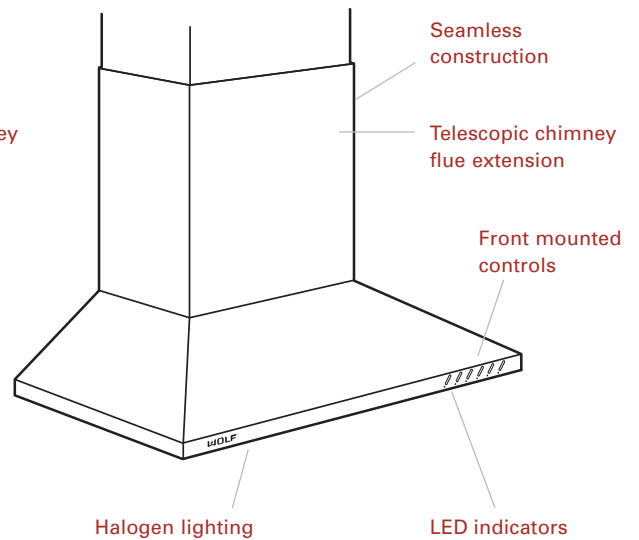
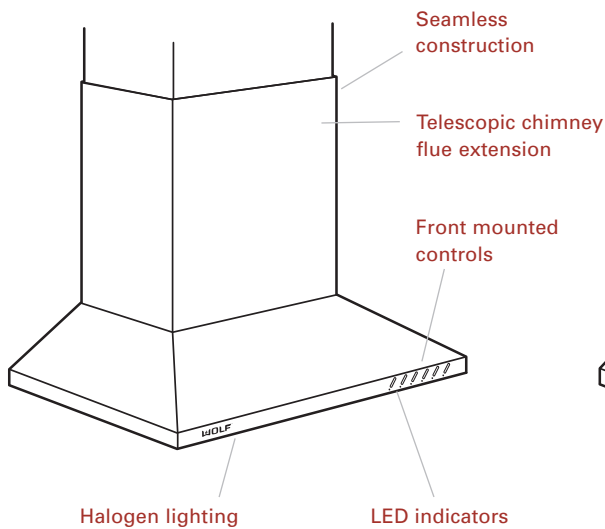



COOKTOP ISLAND HOOD FEATURES

- Classic stainless steel finish
- Internal or remote blower options
- Front-mounted controls with LED indicators
- Heavy-duty stainless steel seamless construction
- Three-speed blower control
- Variable-speed blowers
- Filter clean timer lets you know when the filter needs cleaning
- Delay-off mode automatically turns unit off
- Sealed halogen lighting with three settings
- Stainless steel filter cover with dishwasher safe aluminum mesh filter
- Heat sentry feature automatically turns unit on when heat is sensed and automatically adjusts blower speed
- Transition with backdraft damper included
- Fits 8' (2.4 m) to 9' (2.7 m) ceilings—flue extension to accommodate 10' (3 m) ceilings is available
- UL listed to US and Canadian safety standards
- Two and five year residential warranty – exclusions apply, see warranty on page 15

WOLF WARRANTY

Wolf products are covered by a two and five year residential warranty (exclusions apply). See warranty details at the end of this guide.

IMPORTANT NOTE: The Wolf cooktop island hood is recommended for use with Wolf electric and gas cooktops and integrated modules. It is NOT recommended for use with Wolf dual fuel ranges, gas ranges and range-tops. Any violation of this application may void your warranty for one or both products.

**MODEL IH4227
42" (1067) Cooktop Island Hood**

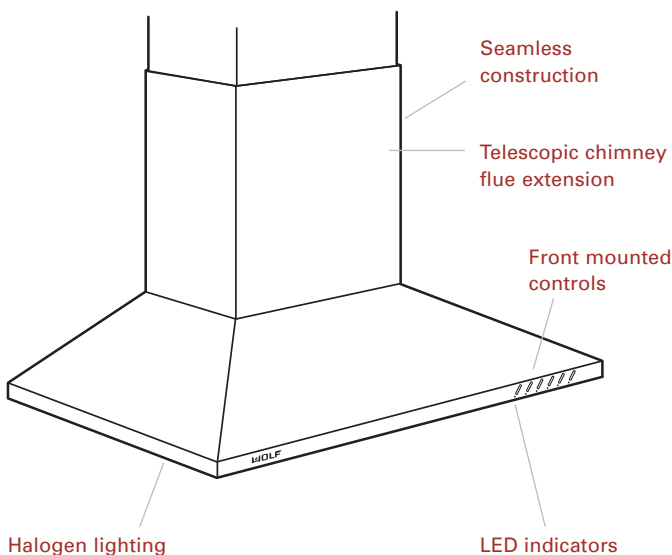

Dimensions in parentheses are in millimeters unless otherwise specified.

VENTILATION HOOD **CONTROLS**

The ventilation hood is operated using the controls along the front edge of the hood.

- The **LIGHT** button turns the halogen lights on and off. The **LIGHT** button also allows you to brighten or dim lighting. Lighting has three levels, high, medium and low.
- The blower operates at three speeds. The **HIGH, MEDIUM** or **LOW** button can be pressed to activate the blower. The corresponding LED indicator will illuminate to indicate the blower speed.

To turn the ventilation hood off, depress the speed control a second time. For example, if you have the blower running at low speed, press the **LOW** button to turn off the blower.

- The LED next to the **FILTER** button on the controls will illuminate when it is time to clean the filters. This indicator light comes on after approximately 30 hours of operation. Refer to Filter Care on page 11.

To reset the **FILTER** clean LED indicator, press the **FILTER** button.

DELAY-OFF MODE

The delay-off mode will allow the ventilation hood blower to continue operating at the selected speed for approximately five minutes after the **DELAY** button has been pressed. This mode allows you to leave the cooking area, while the ventilation hood is still in operation; it will then shut off.

In delay-off mode, both the **DELAY** LED and the corresponding blower speed LED will be illuminated.

- If the blower is on high speed and the **DELAY** button is pressed, the blower will stay on high speed for five minutes. It will then switch to low speed for an additional five minutes before turning off.
- If the blower is on medium speed and the **DELAY** button is pressed, the blower will stay on medium speed for five minutes. It will then switch to low speed for an additional five minutes before turning off.
- If the blower is on low speed and the **DELAY** button is pressed, the blower will stay on low speed for five minutes before turning off.
- If the **DELAY** button is pressed when the blower is off, no operation will take place.
- If the **DELAY** button is pressed when the unit is already in delay-off mode, the delay-off mode will be cancelled.

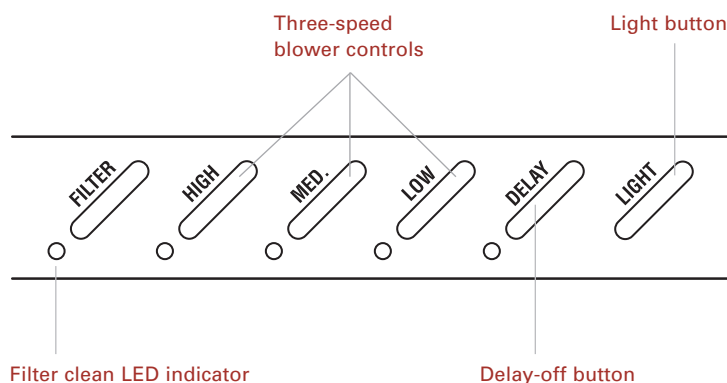
**Ventilation hood controls**



HEAT SENTRY FEATURE

The heat sentry feature will help you maintain your cooking environment and allows your ventilation hood to sense when blower operation is needed.

The heat sentry feature is always in wait and is activated when the exhaust temperature from the hood reaches 206°F (97°C). At this temperature, the blower motor speed will automatically adjust to the next highest speed.

For example, if the blower motor is in low speed and the threshold temperature is reached, the blower will increase to medium speed. The corresponding LED on the control will blink to indicate the heat sentry feature blower speed.

Once heat sentry feature is activated, the ventilation hood will continue to monitor exhaust temperatures every three minutes. If the exhaust temperature reaches 206°F (97°C), the blower speed will increase to the next highest speed and the corresponding LED will blink. If after three minutes the exhaust temperature falls below 174°F (79°C), the blower speed will decrease to the next lowest speed.

If the blower was off prior to heat sentry feature activation, the unit will turn off when exiting the heat sentry feature.

When the blower speed returns to the original setting prior to heat sentry feature activation, the corresponding LED will stop blinking and remain constant. The unit has exited the heat sentry feature.

**HALOGEN** LIGHTING

- The Wolf 30" (762) wall hood requires two halogen bulbs (type T4, 12V, 20W).
- The Wolf 36" (914) wall hood requires three halogen bulbs (type T4, 12V, 20W).
- The Wolf 42" (1067) Island hood requires four halogen bulbs (type T4, 12V, 20W).

ACCESSORIES

Optional accessories are available through your Wolf dealer. To obtain local dealer information, visit the Locator section of our website, wolfappliance.com.

Replacement halogen light bulbs for the Wolf cooktop wall and island hoods are available through your Wolf dealer. To obtain local dealer information, visit the Locator section of our website, wolfappliance.com.

HALOGEN BULB REPLACEMENT**⚠ CAUTION**

Be sure that the bulb is cool before replacing. Halogen bulbs get hot instantly and adjacent parts may retain heat.

- 1) Turn ventilation hood blower and lights off.
- 2) Remove filters from underside of the hood.
- 3) Reach into the underside of the hood and squeeze tabs on the back side of the bulb housing.
- 4) Grasp the front lens assembly and twist to loosen.
- 5) Remove the glass bulb cover and replace the bulb. Use a paper towel when handling the replacement bulb.
- 6) Push the bulb securely into the socket and snap the lens assembly closed.

IMPORTANT NOTE: Use a paper towel when handling the replacement halogen bulb to keep oil on fingers from touching the bulb. Failure to do this will cause the bulb to burn out at first use.

**GENERAL CARE**

Most surfaces of your cooktop wall or island hood are stainless steel. Although resistant to most stains, it is not totally impervious to damage. Salt and some cooking liquids may pit and stain the surface. Always remove these spills immediately.

IMPORTANT NOTE: Be careful not to soak the electronic controls. Although they are sealed, excessive moisture may cause damage to the controls.

CLEANING

Using a clean cloth or sponge, wipe with warm water and mild detergent. Rinse and dry immediately. Apply protective polish, always in the same direction as the grain.

IMPORTANT NOTE: Do not use steel wool pads or abrasive cleaners; they will permanently scratch the surface.

Spray Degreasers: Removes fingerprints and greasy spatters. Spray on a cloth and wipe the surface. Buff dry immediately to avoid streaks.

Hard Water Stains: Use white vinegar and water.

Protective Polish: Apply to the surface to maintain luster and protect from some food stains. Use a soft, non-abrasive stainless steel cleaner like Signature Polish (see side note) and apply with a soft lint-free cloth.

FILTER CARE

The aluminum mesh filters should be cleaned approximately every month, depending on use. The FILTER clean LED on your controls will illuminate when it is time to clean the filters. This indicator light comes on after approximately 30 hours of operation. You may need to clean the filters more often if your cooking style generates large amounts of grease, like frying foods or wok cooking.

The filters and filter covers are dishwasher safe and are designed to fit most dishwashers.

To remove the filters, push the filter toward the back of the hood and rotate the filter downward. Place the aluminum mesh filter and stainless steel cover into the dishwasher at approximately 140°F (60°C), or hand wash, using a biodegradable detergent. When filters are dry, reinstall using the reverse procedure.

IMPORTANT NOTE: DO NOT operate the ventilation hood without the filters. This may cause damage to the blower or other internal components of the hood.

SIGNATURE POLISH

Signature Polish is available from Signature Limited Laboratory, P.O. Box 13436, Dayton, Ohio 45413-0436, or call 877-376-5474 (toll free).



ACCESSORIES

Optional accessories are available through your Wolf dealer. To obtain local dealer information, visit the Locator section of our website, wolfappliance.com.

BLOWER ASSEMBLIES

Wolf cooktop wall and island hoods are shipped without the blower assembly. Internal or remote blower assemblies are available as sales accessories. Use only a Wolf blower with the cooktop ventilation hood.

INTERNAL BLOWERS

- **801643 – (CTBLOWER-45INT)**
450 CFM internal blower for use with the 30" (762) wall hood.
- **801644 – (CTBLOWER-60INT)**
600 CFM internal blower for use with the 36" (914) wall hood or island hood.
- **801645 – (CTBLOWER-90INT)**
900 CFM internal blower for use with the 36" (914) wall hood or island hood.

REMOTE BLOWERS

- **801640 – (CTBLOWER-60REM)**
600 CFM remote blower for use with wall hoods or island hood.
- **801641 – (CTBLOWER-90REM)**
900 CFM remote blower for use with wall hoods or island hood.
- **801642 – (CTBLOWER-120REM)**
1200 CFM remote blower for use with wall hoods or island hood.
- **804701 – (CTBLOWER-150REM)**
1500 CFM remote blower for use with wall hoods or island hood.

IMPORTANT NOTE: Blower options vary with the cooking surface. For recommendations, refer to the Wolf Design Guide found under the Trade section of our website, wolfappliance.com.

VENTILATION HOOD ACCESSORIES

Optional accessories for the Wolf cooktop wall and island hoods are available through your Wolf dealer. To obtain local dealer information, visit the Locator section of our website, wolfappliance.com.

WALL SHIELDS

- **801633 – (CTWALLSHIELD30)**
Stainless steel wall shield for use with wall hoods.
- **801634 – (CTWALLSHIELD36)**
Stainless steel wall shield for use with wall hoods.

FLUE EXTENSIONS

- **801635 – (CTFLUEEXT)**
Flue extension for use with wall hoods. Allows you to increase the height of your wall hood to accommodate 10' (3 m) ceilings.
- **801639 – (IHFLUEEXT)**
Flue extension for use with the island hood. Allows you to increase the height of your island hood to accommodate 10' (3 m) ceilings.



TROUBLESHOOTING GUIDE

PROBLEM	POSSIBLE SOLUTION
Motor and lights do not operate	<p>A fuse in your home may be blown or the circuit breaker tripped. Replace the fuse or reset the circuit breaker.</p> <p>Electrical connections at the electrical box may be made incorrectly. Contact your installer.</p>
Motor runs but lights will not operate	<p>Halogen light bulb(s) may have burned out.</p> <p>The fuse for the light bulb socket may have blown.</p> <p>Switch operation may be faulty.</p>
Motor does not function, but lights are operational	<p>Connect the motor directly to a supply cord, by-passing the hood.</p> <p>If the motor runs, contact a Wolf authorized service center to check switch and control board operation.</p>
Excessive fan speed and/or noise	<p>Check to be sure that the blower wheel is not hitting the side of the blower. Adjust if necessary.</p> <p>Check and tighten blower mounting hardware if necessary.</p> <p>Check for obstructions in the damper flap or duct work.</p> <p>Check for excessive length of the duct run, number of transitions and elbows and duct diameter.</p>

SERVICE INFORMATION

SERVICE INFORMATION

When requesting information, literature, replacement parts or service, always refer to the model and serial number of your ventilation hood. This information is found on the rating plate located on the inside left-hand wall of the hood, above the filter. Record the rating plate information below for future reference.

CONTACT INFORMATION

Wolf Customer Service:
800-332-9513

Website:
wolfappliance.com

Model Number _____

Serial Number _____

Installation Date _____

Wolf Authorized Service Center and Phone

Wolf Dealer and Phone

BEFORE CALLING FOR SERVICE

Before calling your Wolf authorized service center, refer to the Troubleshooting Guide on page 13. Check the household fuse or circuit breaker to see if it has been blown or tripped and that the electrical connection to the appliance has not been disconnected. A power outage may also have caused a disruption in service.

PRODUCT REGISTRATION

Register your new Wolf product today so that we may ensure your satisfaction. You may register by one of the following options:

- 1) Mail in the completed Wolf Product Registration Card.
- 2) Register online at **wolfappliance.com**.
- 3) Register by phone by calling the Wolf Customer Service Department at **800-332-9513**.

The model and serial numbers of your appliance are printed on the enclosed Wolf Product Registration Card. If you provide us with your e-mail address, we will send you exciting new product updates and recipes as they become available, along with information on special events.

The information and images are the copyright property of Wolf Appliance Company, LLC, an affiliate of Sub-Zero Freezer Company, Inc. Neither this book nor any information or images contained herein may be copied or used in whole or in part without the express written permission of Wolf Appliance Company, LLC, an affiliate of Sub-Zero Freezer Company, Inc.

© Wolf Appliance Company, LLC all rights reserved.

WOLF APPLIANCE PRODUCTS LIMITED WARRANTY

RESIDENTIAL USE ONLY

FULL TWO YEAR WARRANTY*

For two years from the date of original installation, your Wolf Appliance product warranty covers all parts and labor to repair or replace any part of the product that proves to be defective in materials or workmanship. All service provided by Wolf Appliance Company under the above warranty must be performed by a Wolf Appliance authorized service center, unless otherwise specified by Wolf Appliance Company. Service will be provided in the home during normal business hours.

LIMITED THIRD THROUGH FIFTH YEAR WARRANTY

From the third through fifth year from the date of original installation, Wolf Appliance Company will repair or replace the following parts that prove to be defective in materials or workmanship. Labor to remove and replace defective parts is not covered. Wolf Appliance Company recommends that you use a Wolf Appliance authorized service center to perform such service.

Gas Burners (excluding appearance), Electric Heating Elements, Blower Motors (vent hoods),
Electronic Control Boards, Magnetron Tubes and Induction Generators

LIMITED LIFETIME WARRANTY

For the life of the product, Wolf Appliance Company will repair or replace any BBQ body or BBQ hood that rusts through due to defective material or workmanship. Labor to remove and replace defective parts is not covered. Wolf Appliance Company recommends that you use a Wolf Appliance authorized service center to perform such service.

TERMS APPLICABLE TO EACH WARRANTY

The warranty applies only to products installed for normal residential use. The warranty applies only to products installed in any one of the fifty states of the United States, the District of Columbia or the ten provinces of Canada. This warranty does not cover any parts or labor to correct any defect caused by negligence, accident or improper use, maintenance, installation, service or repair.

THE REMEDIES DESCRIBED ABOVE FOR EACH WARRANTY ARE THE ONLY ONES THAT WOLF APPLIANCE COMPANY, LLC WILL PROVIDE, EITHER UNDER THIS WARRANTY OR UNDER ANY WARRANTY ARISING BY OPERATION OF LAW. WOLF APPLIANCE COMPANY, LLC WILL NOT BE RESPONSIBLE FOR ANY CONSEQUENTIAL OR INCIDENTAL DAMAGES ARISING FROM THE BREACH OF THIS WARRANTY OR ANY OTHER WARRANTY, WHETHER EXPRESS, IMPLIED OR STATUTORY.

Some states do not allow the exclusion or limitation of incidental or consequential damages, so the above limitation or exclusion may not apply to you. This warranty gives you specific legal rights and you may also have other legal rights that vary from state to state.

To receive parts and/or service and the name of the Wolf Appliance authorized service center nearest you, contact Wolf Appliance Company, LLC, P.O. Box 44848, Madison, Wisconsin 53744; check the Locator section of our website, wolfappliance.com, or call 800-332-9513.

* Stainless Steel (classic, platinum and carbon) doors, panels and product frames are covered by a limited 60 day parts and labor warranty for cosmetic defects.





WOLF APPLIANCE COMPANY, LLC P.O. BOX 44848 MADISON, WI 53744 800-332-9513 WOLFAPPLIANCE.COM

WOLF[®]

807575

9/2005