

This Owner's Manual is provided and hosted by [Appliance Factory Parts](#).



Wolf CTEWH301 Owner's Manual

[Shop genuine replacement parts for Wolf CTEWH301](#)



[Find Your Wolf HVAC Parts - Select From 108 Models](#)

----- Manual continues below -----

COOKTOP LOW-PROFILE HOODS

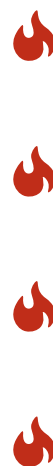

USE & CARE INFORMATION

WOLF[®]



CONTENTS

Introducing Wolf Cooktop Low-Profile Hoods	3
Safety Instructions & Precautions	4
Wolf Cooktop Low-Profile Hood Features	6
Wolf Cooktop Low-Profile Hood Use & Care	8
Troubleshooting Guide	13
Service Information	14
Wolf Warranty	15

As you read this Use & Care Information, take particular note of the **CAUTION** and **WARNING** symbols when they appear. This information is important for safe and efficient use of the Wolf equipment.

▲ CAUTION

signals a situation where minor injury or product damage may occur if you do not follow instructions.

▲ WARNING

states a hazard that may cause serious injury or death if precautions are not followed.

In addition, this Use & Care Information may signal an **IMPORTANT NOTE** which highlights information that is especially important.



THANK YOU

Your purchase of a Wolf cooktop low-profile hood attests to the importance you place upon the quality and performance of your cooking equipment. We understand this importance and have designed and built your ventilation hood with quality materials and workmanship to give you years of dependable service.

We know you are eager to start cooking, but before you do, please take some time to read this Use & Care Information. Whether you are a beginning cook or an expert chef, it will be to your benefit to familiarize yourself with the safety practices, features, operation and care recommendations of the Wolf cooktop low-profile hood.

We appreciate your choice of a Wolf Appliance product and welcome any suggestions or comments you may have. To share your opinions with us, please call 800-332-9513.

Your Wolf ventilation hood is protected by a warranty that is one of the finest in the industry. Take a moment to read the warranty statement on page 15 and refer to it should service become necessary.

IMPORTANT NOTE: Wolf cooktop low-profile hoods are recommended for use with Wolf induction, electric and gas cooktops and integrated modules. For ranges and rangetops, a Wolf Pro ventilation hood is recommended.

CONTACT INFORMATION

Wolf Customer Service:
800-332-9513

Website:
wolfappliance.com

SAFETY INSTRUCTIONS AND PRECAUTIONS

IMPORTANT NOTE: READ AND SAVE THESE INSTRUCTIONS.

- Suitable for use in household cooking area.

⚠ CAUTION

- **Take care when using cleaning agents or detergents.**
- **Two people are required for proper installation.**
- **To reduce the risk of injury, disconnect power before servicing.**
- **To reduce risk of fire and to properly exhaust air, be sure to duct air outside. Do not vent exhaust air into spaces within walls or ceilings or into attics, crawl spaces or garages.**

⚠ WARNING

To reduce the risk of fire or electric shock, do not use this fan with any solid-state speed control device.

⚠ WARNING

TO REDUCE THE RISK OF A COOKTOP GREASE FIRE:

- A)** Never leave surface units unattended at high settings. Boilovers cause smoking and greasy spillovers that may ignite. Heat oils slowly on low or medium settings.
- B)** Always turn hood ON when cooking at high heat or when cooking flaming foods (i.e. Crepes Suzette, Cherries Jubilee, Pepper-corn Beef Flambe’).
- C)** Clean ventilating fans frequently. Grease should not be allowed to accumulate on fan or filter(s).
- D)** Use proper pan size. Always use cookware appropriate for the size of the surface element.

⚠ WARNING

TO REDUCE THE RISK OF FIRE, ELECTRIC SHOCK, OR INJURY TO PERSONS, OBSERVE THE FOLLOWING:

- A)** Use this unit only in the manner intended by the manufacturer. If you have any questions, contact the manufacturer.
- B)** Before servicing or cleaning unit, switch power OFF at service panel and lock panel to prevent power from being switched on accidentally. When the service disconnecting means cannot be locked, securely fasten a prominent warning device, such as a tag, to the service panel.

⚠ WARNING

TO REDUCE THE RISK OF INJURY TO PERSONS IN THE EVENT OF A GREASE FIRE, OBSERVE THE FOLLOWING:

- A)** SMOTHER FLAMES with a close-fitting lid, cookie sheet, or metal tray, then turn off the burner. BE CAREFUL TO PREVENT BURNS. If the flames do not go out immediately EVACUATE AND CALL THE FIRE DEPARTMENT.
- B)** NEVER PICK UP A FLAMING PAN – you may be burned.
- C)** DO NOT USE WATER, including wet dish-cloths or towels – a violent steam explosion will result.
- D)** Use an extinguisher ONLY if:
 - You know you have a Class ABC extinguisher, and you already know how to operate it.
 - The fire is small and contained in the area where it started.
 - The fire department is being called.
 - You can fight the fire with your back to an exit.



⚠ CAUTION

For general ventilating use only. Do not use to exhaust hazardous or explosive material and vapors.

⚠ WARNING

TO REDUCE THE RISK OF FIRE, ELECTRIC SHOCK, OR INJURY TO PERSONS, OBSERVE THE FOLLOWING:

- A)** Installation work and electrical wiring must be done by qualified person(s) in accordance with all applicable codes and standards including fire-rated construction.
- B)** Sufficient air is needed for proper combustion and exhausting of gases through the flue (chimney) of fuel burning equipment to prevent back drafting. Follow the heating equipment manufacturer’s guideline and safety standards such as those published by the National Fire Protection Association (NFPA), and the American Society for Heating, Refrigeration and Air Conditioning Engineers (ASHRAE), and the local code authorities.
- C)** When cutting or drilling into wall or ceiling, do not damage electrical wiring and other hidden utilities.
- D)** Ducted fans must always be vented to the outdoors.

⚠ WARNING

To reduce the risk of fire, use only metal ductwork.

HEAT SENTRY:

- This product is equipped with a thermostat which may start blower automatically. To reduce the risk of injury and to prevent power from being switched on accidentally, switch power OFF at service panel and lock or tag service panel.
- Use only with ventilation hood cord connection kits that have been investigated and found acceptable for use with this model hood.

AUTOMATICALLY OPERATED DEVICE.

IMPORTANT NOTE: TO REDUCE THE RISK OF INJURY, DISCONNECT FROM POWER SUPPLY BEFORE SERVICING. THE UNIT IS EQUIPPED WITH AN INTEGRAL DISCONNECTING SWITCH LOCATED INSIDE THE BLOWER HOUSING.

- Proper maintenance of the ventilation hood will assure proper performance of the unit.
- Avoid using food products that produce flames under the ventilation hood.

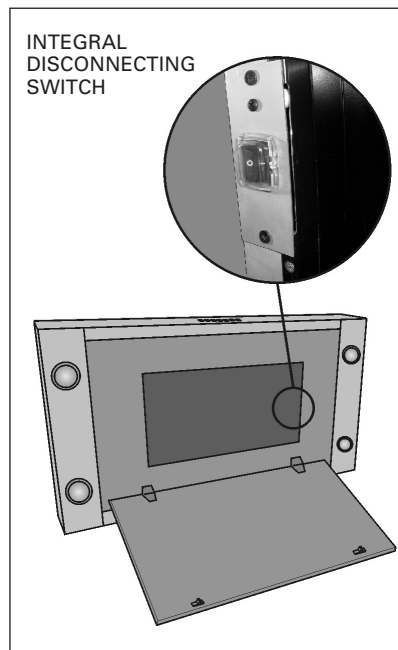

Dimensions in parentheses are in millimeters unless otherwise specified.



LOW-PROFILE WALL HOODS

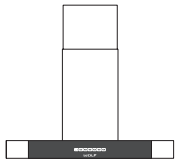

Model CTEWH30

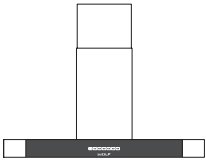

Model CTEWH36(I)

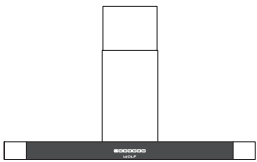

Model CTEWH45(I)

- Heavy-duty stainless steel construction with classic stainless steel finish
- 500 CFM Internal blower included with (I) models
- In-line or remote blower options for Models CTEWH36 and CTEWH45
- Front-mounted electronic controls with digital indicator
- Four-speed blower control
- Filter clean indicator lets you know when grease filter needs cleaning
- Delay-off mode automatically turns unit off
- Sealed halogen lighting with three settings
- Stainless steel filter cover(s) with dishwasher safe aluminum mesh grease filter(s)
- Heat Sentry feature automatically turns unit ON when heat is sensed and automatically adjusts blower speed
- Telescopic flue fits 8' (2.4 m) to 9' (2.7 m) ceilings
- Internal blower (I) models can be used in a non-ducted application using an accessory charcoal recirculating filter
- Transition with backdraft damper included
- UL listed to US and Canadian safety standards
- Two and five year residential warranty

LOW-PROFILE WALL HOOD

Model CTEWH36 shown

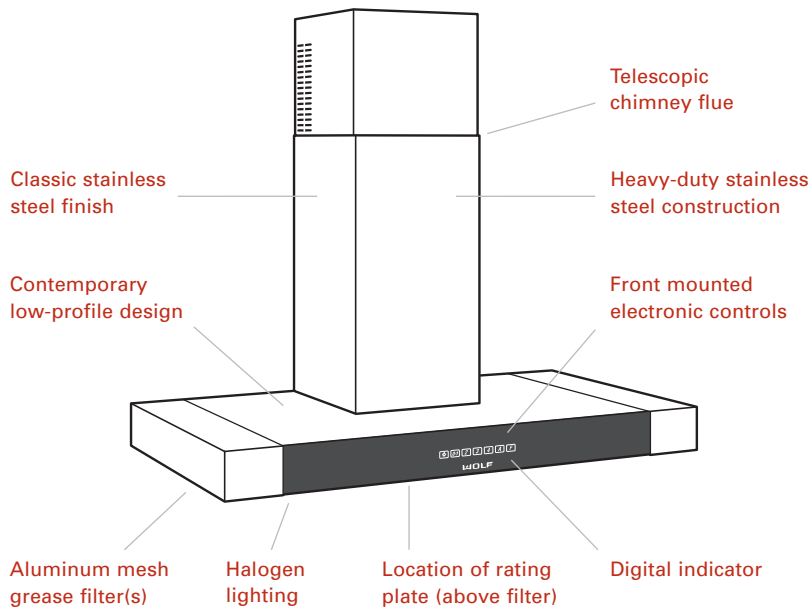



LOW-PROFILE ISLAND HOOD

- Heavy-duty stainless steel construction with classic stainless steel finish
- 500 CFM Internal blower included
- Front-mounted electronic controls with digital indicator
- Four-speed blower control
- Filter clean indicator lets you know when grease filters need cleaning
- Delay-off mode automatically turns unit off
- Sealed halogen lighting with three settings
- Stainless steel filter covers with dishwasher safe aluminum mesh grease filters
- Heat Sentry feature automatically turns unit ON when heat is sensed and automatically adjusts blower speed
- Telescopic flue fits 8' (2.4 m) to 9' (2.7 m) ceilings
- Can be used in a non-ducted application using an accessory charcoal recirculating filter
- Transition with backdraft damper included
- UL listed to US and Canadian safety standards
- Two and five year residential warranty

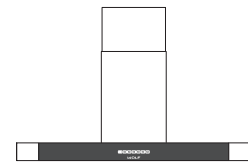

Model CTEIH42I

WOLF
WARRANTY

Wolf products are covered by a two and five year residential warranty (exclusions apply). See warranty details at the end of this guide.

LOW-PROFILE ISLAND HOOD

Model CTEIH42I

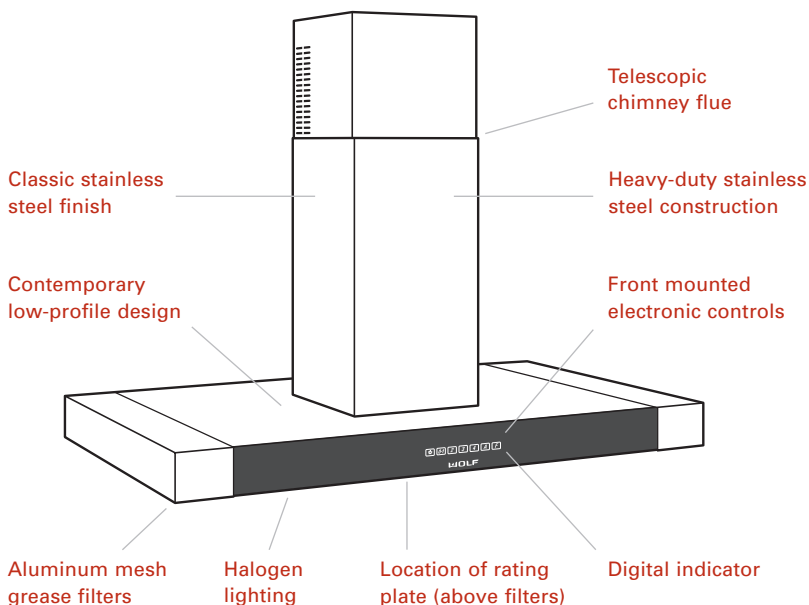

Dimensions in parentheses are in millimeters unless otherwise specified.

HEAT SENTRY THERMOSTAT

Your hood is equipped with a HEAT SENTRY™ thermostat. This thermostat is a device that will turn on or increase the speed of the blower if it senses excessive heat above the cooking surface.

- If the blower is OFF, it turns the blower ON to HIGH speed.
- If the blower is ON at a lower speed setting, it increases the blower speed to HIGH.

When the temperature level drops to normal, the blower will return to its original setting.

⚠ WARNING

The HEAT SENTRY thermostat can start the blower even if the hood is turned OFF. When this occurs, it is impossible to turn the blower OFF with its switch. If you must stop the blower, do it from the main electrical panel.

HOOD **CONTROLS**

The Wolf cooktop low-profile hood is operated using the touch control pads on the front face of the hood. Refer to the illustration below.

- L) LIGHTS.** Touch the pad once to turn the lights ON, touch a second time to turn the lights ON to a brighter level and touch a third time to turn the lights OFF.
- 1) A touch activates the blower motor at the first speed (icon is illuminated). Press the pad for about two seconds to turn the blower OFF.
 - 2) Activates the blower at the second speed.
 - 3) Activates the blower at the third speed.
 - 4) Activates the blower at the fourth speed.
- A) Touch the pad to set a **TIMER** which keeps the blower operating at the current speed for 10 minutes.**
- F) FILTER.** After 30 hours of operation, the icon is illuminated to indicate that the grease filter(s) must be cleaned. After 120 hours, the icon flashes to indicate that the grease filter(s) must be cleaned and the charcoal filter replaced. To reset the hour counter, touch (**F**) while the icon is illuminated or flashing.

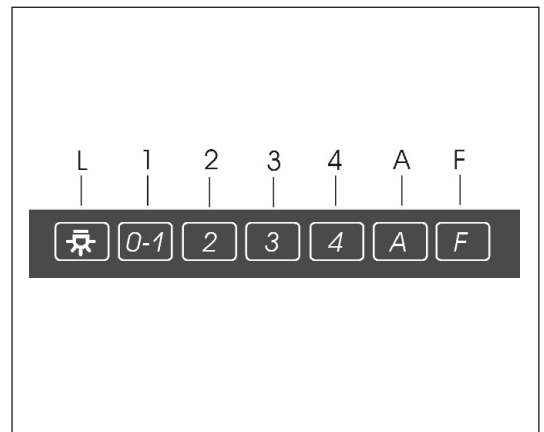

Hood controls

**GREASE** FILTER(S)

30" (762) and 36" (914) low-profile wall hoods have one aluminum mesh grease filter and the 45" (1143) wall hood has two. The low-profile island hood also has two grease filters.

The grease filter(s) should be cleaned at regular intervals, depending on use. The **(F)** icon in the hood controls will illuminate to indicate when the grease filter(s) should be cleaned. This indicator light comes on after approximately 30 hours of operation. To reset the hour counter, touch the **(F)** control pad while the icon is illuminated.

IMPORTANT NOTE: You may need to clean the filter(s) more often if your cooking style generates large amounts of grease, like frying foods or wok cooking.

GREASE FILTER REMOVAL

To access the filter(s), gently press up on the front edge and allow the panel to rotate downward as shown in the illustration below. Push the handle outward and pull the filter downward to remove.

The aluminum mesh filter(s) and stainless steel filter cover(s) are dishwasher safe and are designed to fit most dishwashers. Place filter(s) and filter cover(s) into the dishwasher at approximately 140°F (60°C), or hand wash, using a biodegradable detergent.

When filter(s) are dry, reinstall using the reverse procedure.

IMPORTANT NOTE: DO NOT operate the ventilation hood without the filter(s). This may cause damage to the blower or other internal components of the hood.

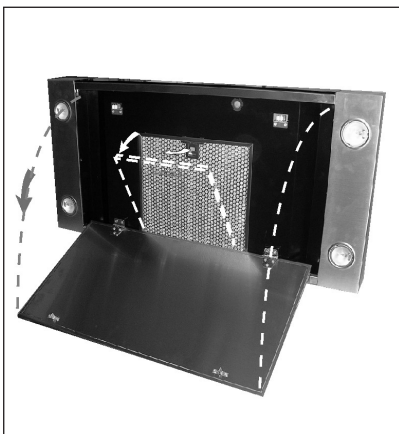

Grease filter removal—wall hood shown



CHARCOAL FILTER

If the ventilation hood is used in a recirculating application, the charcoal filter must be replaced at regular intervals. The **(F)** icon in the hood controls will flash to indicate when the charcoal filter needs to be replaced. This indicator light flashes after approximately 120 hours of operation. To reset the hour counter, press the **(F)** control pad while the icon is flashing.

CHARCOAL FILTER REMOVAL

First remove the grease filter(s). To access the filter(s), gently press up on the front edge and allow the panel to rotate downward as shown in the illustration on page 9. Push the handle outward and pull the grease filter downward to remove.

Then remove the charcoal filter as shown in illustrations below. Push the catch towards the inside and turn the charcoal filter so that the two filter clips slip out of their seats.

Install the new charcoal filter using the reverse procedure.

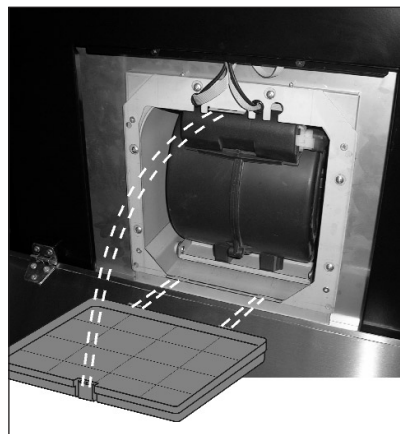

Charcoal filter removal—wall hood

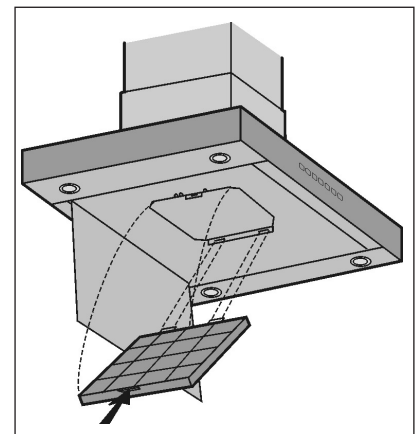

Charcoal filter removal—**island hood**



HALOGEN LIGHTING

Wolf cooktop low-profile wall and island hoods use halogen light bulbs.

Replacement halogen bulbs are available through your Wolf dealer. To obtain local dealer information, visit the Showroom Locator section of our website, wolfappliance.com.

HALOGEN BULB REPLACEMENT

⚠ WARNING

Always switch off the electrical supply before carrying out any operation on the appliance.

To replace the halogen light bulbs: Open the light cover by pressing in the slots as shown in the illustration below. Replace with halogen bulbs of the same type.

IMPORTANT NOTE: Use a paper towel when handling the replacement halogen bulb to keep oil on fingers from touching the bulb. Failure to do this will cause the bulb to burn out at first use.

ACCESSORIES

Optional accessories are available through your Wolf dealer. To obtain local dealer information, visit the Showroom Locator section of our website, wolfappliance.com.

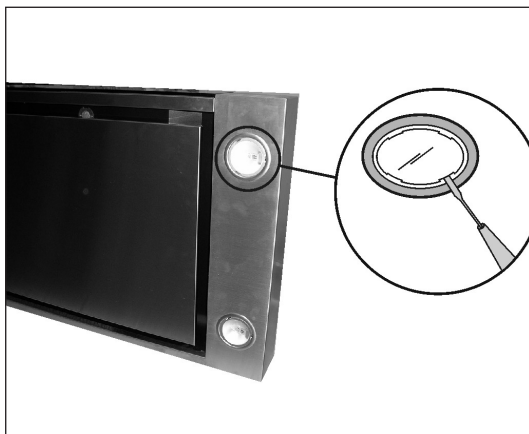

Halogen bulb removal

Dimensions in parentheses are in millimeters unless otherwise specified.

**GENERAL CARE**

Most surfaces of your cooktop low-profile hood are stainless steel. Although resistant to most stains, it is not totally impervious to damage. Salt and some cooking liquids may pit and stain the surface. Always remove these spills immediately.

**SIGNATURE
POLISH**

Signature Polish is available from Signature Limited Laboratory, P.O. Box 13436, Dayton, Ohio 45413-0436, or call 877-376-5474 (toll free).

CLEANING

Using a clean cloth or sponge, wipe with warm water and mild detergent. Rinse and dry immediately. Apply protective polish, always in the same direction as the grain.

IMPORTANT NOTE: Do not use steel wool pads or abrasive cleaners; they will permanently scratch the surface.

Spray Degreasers: Removes fingerprints and greasy spatters. Spray on a cloth and wipe the surface. Buff dry immediately to avoid streaks.

Hard Water Stains: Use white vinegar and water.

Protective Polish: Apply to the surface to maintain luster and protect from some food stains. Use a soft, non-abrasive stainless steel cleaner like Signature Polish (see side note) and apply with a soft lint-free cloth.



TRUBLESHOOTING GUIDE

PROBLEM	POSSIBLE SOLUTION
Blower and lights do not operate	<p>A fuse in your home may be blown or the circuit breaker tripped. Replace the fuse or reset the circuit breaker.</p> <p>Electrical connections at the electrical box may be made incorrectly. Contact your installer.</p>
Blower runs but lights will not operate	<p>Halogen light bulb(s) may have burned out.</p> <p>The fuse for the light bulb socket may have blown.</p> <p>Switch operation may be faulty.</p>
Blower does not function, but lights are operational	<p>Connect the blower directly to a supply cord, by-passing the hood.</p> <p>If the blower motor runs, contact a Wolf authorized service center to check switch and control board operation.</p>
Excessive blower speed and/or noise	<p>Check to be sure that the blower wheel is not hitting the side of the housing. Adjust if necessary.</p> <p>Check and tighten blower mounting hardware if necessary.</p> <p>Check for obstructions in the damper flap or ductwork.</p> <p>Check for excessive length of the duct run, number of transitions and elbows and duct diameter.</p>

CONTACT INFORMATION

Wolf Customer Service:
800-332-9513
Website:
wolfappliance.com



SERVICE INFORMATION

When requesting information, literature, replacement parts or service, always refer to the model and serial number of your ventilation hood. This information is found on the product rating plate located on the underside of the hood, above the grease filter(s). The filter(s) must be removed to access the rating plate. Refer to the illustrations on pages 6–7. Record the rating plate information below for future reference.

CONTACT INFORMATION

Wolf Customer Service:
800-332-9513

Website:
wolfappliance.com

Model Number _____

Serial Number _____

Installation Date _____

Wolf Authorized Service Center and Phone

Wolf Dealer and Phone

BEFORE CALLING FOR SERVICE

Before calling your Wolf authorized service center, refer to the Troubleshooting Guide on page 13. Check the household fuse or circuit breaker to see if it has been blown or tripped and that the electrical connection to the appliance has not been disconnected. A power outage may also have caused a disruption in service.

PRODUCT REGISTRATION

Register your new Wolf product today so that we may ensure your satisfaction. You may register by one of the following options:

- 1) Mail in the completed Wolf Product Registration Card.
- 2) Register online at **wolfappliance.com**.
- 3) Register by phone by calling the Wolf Customer Service Department at **800-332-9513**.

The model and serial numbers of your appliance are printed on the enclosed Wolf Product Registration Card. If you provide us with your e-mail address, we will send you exciting new product updates and recipes as they become available, along with information on special events.

The information and images in this book are the copyright property of Wolf Appliance, Inc., an affiliate of Sub-Zero, Inc. Neither this book nor any information or images contained herein may be copied or used in whole or in part without the express written permission of Wolf Appliance, Inc., an affiliate of Sub-Zero, Inc.

©Wolf Appliance, Inc. all rights reserved.

Wolf Appliance Products Limited Warranty

RESIDENTIAL USE ONLY

FULL TWO YEAR WARRANTY*

For two years from the date of original installation, your Wolf Appliance product warranty covers all parts and labor to repair or replace any part of the product that proves to be defective in materials or workmanship. All service provided by Wolf Appliance under the above warranty must be performed by a Wolf Appliance authorized service center, unless otherwise specified by Wolf Appliance. Service will be provided in the home during normal business hours.

LIMITED THIRD THROUGH FIFTH YEAR WARRANTY

From the third through fifth year from the date of original installation, Wolf Appliance will repair or replace the following parts that prove to be defective in materials or workmanship. Labor to remove and replace defective parts is not covered. Wolf Appliance recommends that you use a Wolf Appliance authorized service center to perform such service.

Gas Burners (excluding appearance), Electric Heating Elements, Blower Motors (vent hoods), Electronic Control Boards, Magnetron Tubes and Induction Generators

LIMITED LIFETIME WARRANTY

For the life of the product, Wolf Appliance will repair or replace any outdoor gas grill body or hood that rusts through due to defective material or workmanship. Labor to remove and replace defective parts is not covered. Wolf Appliance recommends that you use a Wolf Appliance authorized service center to perform such service.

TERMS APPLICABLE TO EACH WARRANTY

The warranty applies only to products installed for normal residential use. The warranty applies only to products installed in any one of the fifty states of the United States, the District of Columbia or the ten provinces of Canada. This warranty does not cover any parts or labor to correct any defect caused by negligence, accident or improper use, maintenance, installation, service or repair.

THE REMEDIES DESCRIBED ABOVE FOR EACH WARRANTY ARE THE ONLY ONES THAT WOLF APPLIANCE, INC. WILL PROVIDE, EITHER UNDER THIS WARRANTY OR UNDER ANY WARRANTY ARISING BY OPERATION OF LAW. WOLF APPLIANCE, INC. WILL NOT BE RESPONSIBLE FOR ANY CONSEQUENTIAL OR INCIDENTAL DAMAGES ARISING FROM THE BREACH OF THIS WARRANTY OR ANY OTHER WARRANTY, WHETHER EXPRESS, IMPLIED OR STATUTORY.

Some states do not allow the exclusion or limitation of incidental or consequential damages, so the above limitation or exclusion may not apply to you. This warranty gives you specific legal rights and you may also have other legal rights that vary from state to state.

To receive parts and/or service and the name of the Wolf Appliance authorized service center nearest you, contact Wolf Appliance, Inc., P.O. Box 44848, Madison, Wisconsin 53744; check the Contact & Support section of our website, wolfappliance.com, or call 800-332-9513.

*Stainless Steel (classic, platinum and carbon) doors, panels and product frames are covered by a limited 60 day parts and labor warranty for cosmetic defects.





WOLF APPLIANCE, INC. P. O. BOX 44848 MADISON, WI 53744 800-332-9513 WOLFAPPLIANCE.COM

WOLF[®]

812507 / 04308007 5/2008



812507\$RevA