



WOOD FIRE GRILLS™

REVOLUTIONIZING OUTDOOR COOKING™



WWW.HEARTHANDPRODUCTS.COM

888.883.2260



MEMPHIS WOOD FIRE GRILLS™

REVOLUTIONIZING OUTDOOR COOKING!™

Memphis Grills continue to revolutionize outdoor cooking! Memphis Wood Fire Grills are **3-in-1 Outdoor Cooking Centers**. They combine the following wood-fired appliances:

- High-Temperature Grill
- Low 'n' Slow Smoker
- High Performance Convection Oven

No other pellet, gas, charcoal, or propane grill on the market today can accurately claim to have the full convection capabilities that Memphis offers. Superior craftsmanship, versatile capabilities, and advanced Intelligent Temperature Control (ITC) truly put Memphis in a class of its own.

VERSATILITY

Expand your kitchen to the outside! Unlike ordinary grills, high-end 3-in-1 Memphis Grills have true convection capabilities, as well as grilling and smoking features. Bake a pie, sear a steak, cook a wood-fired pizza, or smoke a brisket. As an additional cooking source, Memphis Grills make holidays and other gatherings easier and more enjoyable!



INTELLIGENT TEMPERATURE CONTROL

Eliminate constant tending to the fire or overcooking your food from direct or indirect heat. Fueled by 100% natural wood pellets, our one-touch Intelligent Temperature Control (ITC) automatically maintains your desired temperature (180 to 650 degrees*) — just like an indoor oven! The precision and dependability of the ITC allow for year-round, all-weather cooking — even in the most inclement weather conditions.



* Temperature range varies by model.

WOOD-FIRED FLAVOR

Enjoy the delicious wood-fired flavors that restaurants provide, in the comfort of your own backyard! The ITC and automatic fueling system cook with 100% natural wood pellets to produce a multitude of savory flavors. From a mild smoked taste to hints of cherry, hickory, or maple, a variety of wood flavors are available that will suit any preference. You'll be amazed at the taste difference compared to traditional gas or charcoal grills.



Wood-Fired Pizza Oven Capabilities

BAKING AND ROASTING

Bake bread, pizza, cookies, or even a pie with our consistent oven temperatures and even heat circulation. Or roast any type or cut of meat to absolute perfection!

SEARING

Sear meats first to seal in precious juices and enhance their flavor. Choose between the Memphis Pro, which achieves temperatures of 650 degrees, the Memphis Advantage, which reaches 600 degrees, and the Memphis Select, which ranges to 500 degrees.

SMOKING

For maximum flavor and tenderness, simply set the ITC to "smoke mode" and select the desired temperature (from 180 to 295 degrees) to create succulent ribs, briskets, and roasts.

HEAVY-DUTY STEEL, QUALITY CONSTRUCTION, AND MADE IN THE USA!

Our superior craftsmanship and strict adherence to manufacturing standards guarantee products with unbeatable reliability and durability in any climate or weather condition. All Memphis Wood Fire Grills are designed, engineered and manufactured in the USA and are backed by a 5-year limited warranty.

ENVIRONMENTALLY FRIENDLY

Cooking with 100% natural wood pellets is safer and more environmentally conscientious than using more traditional products. Unlike such fossil fuels as natural gas and propane that contribute to climate change, our pellets are always made from renewable resources.



TRUE CONVECTION COOKING

Prepare flavorful and juicy foods without constantly tending the grill. And because all Memphis Wood-Fired Grills are true convection ovens, no rotisserie is needed. Grill chamber design, advanced engineering, and convection fans circulate heat evenly and provide the consistent temperatures required for convection oven performance. Other brands may claim to have convection oven capabilities, but Memphis Grills can accurately backup that claim with engineering facts.



MEMPHIS PRO™

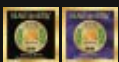

MEMPHIS ADVANTAGE™



MEMPHIS SELECT™



MEMPHIS PRO™ BUILT-IN





MEMPHIS PRO™



Intelligent Temperature Control (ITC) with Auto Start. Simply press ON, set the desired temperature from 180 to 650 degrees, relax, and leave the work to your Memphis Pro. ITC comes standard and makes Memphis the intelligent choice.

5-Year Limited Warranty



MEMPHIS PRO SPECIFICATIONS *(Standard Configuration)*

Product Code	Description	Cooking Surface	Cooking Surface with Optional Grates	Cubic Inch Cooking Area	Unit Weight	Dimensions	Temperature Range
VG0001S	304 Stainless Steel	562 sq. in.	834 sq. in.	3,905 cub. in.	216 lb.	H47" x W57" x D29"	180–650° F
VG0001	Charcoal Metallic Painted	562 sq. in.	834 sq. in.	3,905 cub. in.	216 lb.	H47" x W57" x D29"	180–650° F

FEATURE SPECIFICATIONS

Material Heavy-Duty Double Wall and Sealed Construction	Grill Grate .312" Diameter 304 Stainless Steel Rods	Convection Fan System Dual Fan Combustion/Convection System	Grill Construction Sealed and Insulated Dual Walls Throughout Entire Cooking Area
Temperature Controls One-Touch Digital Intelligent Temperature Control (Standard)	Fuel System Automatic Dual Auger Self-Feeding Pellet Fuel System	Hopper Capacity 16 lb. Wood Pellet Dual Bin Hopper	Wheels 4 Heavy-Duty Locking Casters

OPTIONS

- VG4000 Small Cooking Grate (2 per kit)
- VG4001 Large Cooking Grate (2 per kit)
- VGCOVER-1 Memphis Pro Grill Cover



Dual Fan Convection System provides convection cooking and even heat circulation for tender and juicy results.



Sealed and insulated double wall construction provides superior heat retention and consistent temperatures in all weather conditions.



16 lb. high-capacity wood pellet hopper with two 8 lb. dual fuel bins. Satisfy any culinary preference by automatically mixing a variety of flavors.



MEMPHIS ADVANTAGE™



Intelligent Temperature Control (ITC) with Auto Start. Simply press ON, set the desired temperature from 200 to 600 degrees, relax, and leave the work to your Memphis Advantage. ITC comes standard and makes Memphis the intelligent choice.

5-Year Limited Warranty



MEMPHIS ADVANTAGE SPECIFICATIONS *(Standard Configuration)*

Product Code	Description	Cooking Surface	Cooking Surface with Optional Grates	Cubic Inch Cooking Area	Unit Weight	Dimensions	Temperature Range
VG0050	Charcoal Metallic Painted with Side Shelves	427 sq. in.	970 sq. in.	4,510 cub. in.	195 lb.	H47" x W44.5" x D29"	200–600° F

Material

Heavy-Duty Double Wall Construction

Grill Grate

.312" Diameter 304 Stainless Steel Rods

Convection Fan System

Single Fan Combustion/Convection System

Grill Construction

Double Wall Grill Body, with Sealed Dual Wall Hood

Temperature Controls

One-Touch Digital Intelligent Temperature Control (Standard)

Fuel System

Automatic Single Auger Self-Feeding Pellet Fuel System

Hopper Capacity

12 lb. Wood Pellet Hopper

Wheels

4 Heavy-Duty Locking Casters

OPTIONS

- VG4000 Small Cooking Grate (2 per kit)
- VG4001 Large Cooking Grate (2 per kit)
- VGCOVER-3 Memphis Grill Cover with Side Shelves



Single Fan System for even heat distribution throughout the cooking area. The Memphis Advantage's convection cooking produces flavorful and succulent results, with no rotisserie.



Dual walls enable year-round grilling. Enjoy delicious wood-fired flavors in all seasons — even if it's snowing.



Large 12 lb. hopper capacity accommodates hours of overnight smoking.



* Memphis Select shown with optional side shelves.

MEMPHIS SELECT™



Intelligent Temperature Control (ITC) with Auto Start. Simply press ON, set the desired temperature from 200 to 500 degrees, relax, and leave the work to your Memphis Select. ITC comes standard and makes Memphis the intelligent choice.

5-Year Limited Warranty



MEMPHIS SELECT SPECIFICATIONS (Standard Configuration)

Product Code	Description	Cooking Surface	Cooking Surface with Optional Grates	Cubic Inch Cooking Area	Unit Weight	Dimensions	Temperature Range
VG0070	Charcoal Metallic Painted	427 sq. in.	699 sq. in.	3,750 cub. in.	132 lb.	H46" x W26" x D31"	200–500° F

FEATURE SPECIFICATIONS

Material Heavy-Duty Steel Construction	Grill Grate Porcelain-Coated Cooking Grates	Convection Fan System Single Fan Combustion/Convection System	Grill Construction Single Wall Construction
Temperature Controls One-Touch Digital Intelligent Temperature Control (Standard)	Fuel System Automatic Single Auger Self-Feeding Pellet Fuel System	Hopper Capacity Up to 12 lb. of Wood Pellets	Wheels Convenient Caster System

OPTIONS

- VG0740 Memphis-Select L/R Side Shelf Kit (Total Dimensions H46" x W26" x D31")
- VG4000 Small Cooking Grate (2 per kit)
- VGCOVER-2 Memphis Grill Cover without Side Shelves
- VGCOVER-3 Memphis Grill Cover with Side Shelves



Single Fan System for even heat distribution throughout the cooking area. The Memphis Select's convection cooking produces flavorful and succulent results, with no rotisserie.



Large 12 lb. hopper capacity accommodates hours of overnight smoking.



Single wall, heavy-duty construction for durable long-term grilling.



MEMPHIS PRO™ BUILT-IN



Intelligent Temperature Control (ITC) with Auto Start. Simply press ON, set the desired temperature from 180 to 650 degrees, relax, and leave the work to your Memphis Built-In. ITC comes standard and makes Memphis the intelligent choice.



5-Year Limited Warranty



MEMPHIS PRO BUILT-IN SPECIFICATIONS (Standard Configuration)

Product Code	Description	Cooking Surface	Cooking Surface with Optional Grates	Cubic Inch Cooking Area	Unit Weight	Dimensions	Temperature Range
VGB0001S	304 Stainless Steel	562 sq. in.	834 sq. in.	3,905 cub. in.	216 lb.	H27" x W28" x D29"	180-650° F
VGB0001	Charcoal Metallic Painted	562 sq. in.	834 sq. in.	3,905 cub. in.	216 lb.	H27" x W28" x D29"	180-650° F

FEATURE SPECIFICATIONS

Material Heavy-Duty Double Wall and Sealed Construction	Grill Grate .312" Diameter 304 Stainless Steel Rods	Convection Fan System Dual Fan Combustion/Convection System	Grill Construction Sealed and Insulated Dual Walls Throughout Entire Cooking Area
Temperature Controls One-Touch Digital Intelligent Temperature Control (Standard)	Fuel System Automatic Dual Auger Self-Feeding Pellet Fuel System	Hopper Capacity 16 lb. Wood Pellet Dual Bin Hopper	

The Memphis Pro Built-In has the same performance features as the Memphis Pro. Please refer to the Memphis Pro page for more details.

CONTROL CABLE WAY

ITC CONTROL LOCATION REQUIRES 110/120 V AC

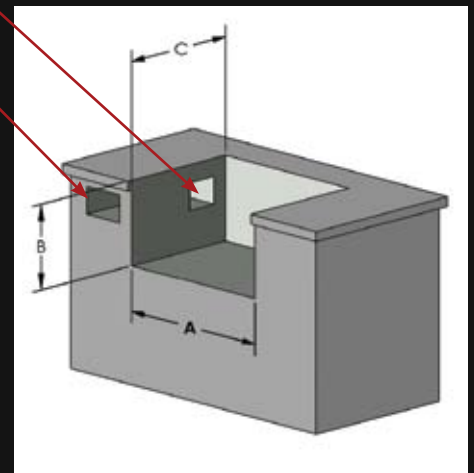
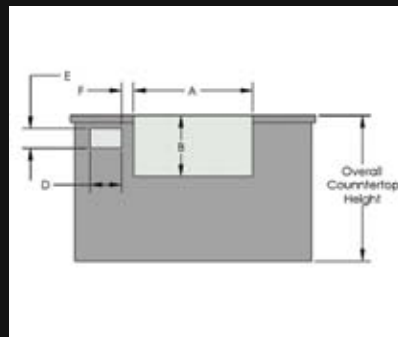
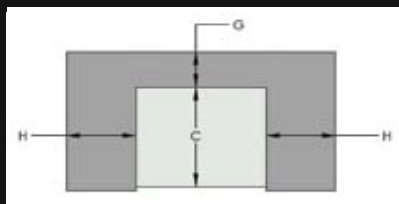

A=30" B=15.4" C=23" D=8" E=5" F=3-12" G=6" Minimum Clearance F=18" Minimum Clearance

MEMPHIS WOOD FIRE GRILLS™

AT A GLANCE

Product Code	Description	ITC	Convection Fan System	Grill Construction	Cooking Surface	Cooking Surface with Optional Grates	Cubic Inch Cooking Area	Hopper	Unit Weight	Dimensions	Temp Range
--------------	-------------	-----	-----------------------	--------------------	-----------------	--------------------------------------	-------------------------	--------	-------------	------------	------------

MEMPHIS PRO SPECIFICATIONS (Standard Configuration)

VG0001S	Stainless Steel	Yes	2	Heavy-Duty Double Wall and Sealed Construction	562 sq. in.	834 sq. in.	3,905 cub. in.	16 lb.	216 lb.	H47" x W57" x D29"	180–650° F
VG0001	Charcoal Metallic	Yes	2	Heavy-Duty Double Wall and Sealed Construction	562 sq. in.	834 sq. in.	3,905 cub. in.	16 lb.	216 lb.	H47" x W57" x D29"	180–650° F

MEMPHIS ADVANTAGE SPECIFICATIONS (Standard Configuration)

VG0050	Charcoal Metallic w/ Side Shelves	Yes	1	Heavy-Duty Double Wall Construction	427 sq. in.	970 sq. in.	4,510 cub. in.	12 lb.	195 lb.	H47" x W44.5" x D29"	200–600° F
--------	-----------------------------------	-----	---	-------------------------------------	-------------	-------------	----------------	--------	---------	----------------------	------------

MEMPHIS SELECT SPECIFICATIONS (Standard Configuration)

VG0070	Charcoal Metallic Painted	Yes	1	Heavy-Duty Steel Construction	427 sq. in.	699 sq. in.	3,750 cub. in.	12 lb.	132 lb.	H46" x W26" x D31"	200–500° F
--------	---------------------------	-----	---	-------------------------------	-------------	-------------	----------------	--------	---------	--------------------	------------

MEMPHIS PRO BUILT-IN SPECIFICATIONS (Standard Configuration)

VGB0001S	Stainless Steel	Yes	2	Heavy-Duty Double Wall and Sealed Construction	562 sq. in.	834 sq. in.	3,905 cub. in.	16 lb.	185 lb.	H27" x W28" x D29"	180–650° F
VGB0001	Charcoal Metallic Painted	Yes	2	Heavy-Duty Double Wall and Sealed Construction	562 sq. in.	834 sq. in.	3,905 cub. in.	16 lb.	185 lb.	H27" x W28" x D29"	180–650° F

ALL MODELS DESIGNED, ENGINEERED, AND MANUFACTURED IN THE USA



All grills require 110/120V power with ground.



ENHANCE FLAVORS AND YOUR GRILL PERFORMANCE WITH NATURE'S WAY BBQ PELLETS

- 100% Renewable Hard Wood Pellets
- Available in Your Choice of 7 Delicious Flavors (All Purpose, Adler, Apple, Cherry, Hickory, Maple, Mesquite)
- Safe, Portable, and Easy-to-Use 20 lb. Bags



HEARTH LAND PRODUCTS, LLC 9111 GRAND AVENUE SOUTH BLOOMINGTON, MN 55420
888.883.2260 WWW.HEARTH LANDPRODUCTS.COM

Available From: