

This Owner's Manual is provided and hosted by [Appliance Factory Parts](#).



TWIN EAGLES TEBQ36G-B Owner's Manual

[Shop genuine replacement parts for TWIN EAGLES
TEBQ36G-B](#)



[Find Your TWIN EAGLES Grill Parts - Select From 58 Models](#)

----- Manual continues below part list -----

Available Replacement Parts for TWIN EAGLES TEBQ36G-B

14625	warming rack universal, 15 x 6.5
S15303	REGULATOR NAT
S-13129-12	BRIQUETTES ONLY
S-13144	Screen Mesh (For optional Sear Zone Burn
s16321Y	HOT SURFACE IGNITER, MAIN BURNER
S15302	REGULATOR LIQUID PROPANE
S16270	HALOGEN LIGHT COMPLETE
S16191-1	BULB, HALOGEN LIGHT
S-15340	THERMOMETER
S16196	SWITCH, FRONT PANEL & LIGHTS
S13154	KNOB, CHROME
S16233Y	Transformer Assembly .
S-14226	Springs kit, hood
S16194	SWITCH, HOOD



TWIN EAGLES GAS GRILL INSTALLATION, USE & CARE MANUAL



TEBQ42R with optional TEGB42SD-B Grill Base shown.

Models: TEBQ30G-B
TEBQ30R-B
TEBQ36G-B
TEBQ36R-B
TEBQ42G-B
TEBQ42R-B

A special message. . .

Congratulations on your purchase of TWIN EAGLES gas barbecue grill. In addition to its Unique Style, Superb Performance and High Quality, this grill is built with pride in the U.S.A. Twin Eagles is committed to making outdoor cooking products you'll be proud to own for years.

This manual gives you easy to follow instructions for installing, operating and maintaining your TWIN EAGLES grill. We recommend reading this manual carefully before your first use to insure safety, proper care and operation.

Thank you and welcome!

TWIN EAGLES

FOR YOUR RECORDS

Please record the following information and refer to them when contacting the company or an authorized service agent. This information is found on the data nameplate, located on the panel behind the control panel of the grill. Remove the drip pan to visually access the nameplate from the front of the grill. A second label with model number and serial number is located under the right side of the control panel.

Model #: _____

Serial #: _____

Date of Purchase: _____

Place of Purchase: _____

Type of Gas: NG LP



IMPORTANT SAFETY INFORMATION – TWIN EAGLES GAS GRILL

WARNING! Read this manual carefully and completely before using your grill to ensure proper operation, proper installation, proper servicing and to reduce the risk of fire, burn hazard and/ or other injury.

FOR YOUR SAFETY

If you smell gas:

1. Shut off gas to the appliance.
2. Extinguish any open flames.
3. Open lid.
4. If odor continues, keep away from the appliance and immediately call your gas supplier or fire department.

AVERTISSEMENT

S'il y a une odeur de gaz:

1. Coupez l'admission de gaz de l'appareil.
2. Éteindre toute flamme nue.
3. Ouvrir le couvercle.
4. Si l'odeur continue, évite l'appareil et appelle tout de suite votre fournisseur de gaz ou les pompiers.

FOR YOUR SAFETY

1. Do not store or use gasoline or other flammable vapors and liquids in the vicinity of this or any other appliance.
2. An LP cylinder not connected for use shall not be stored in the vicinity of this or any other appliance.

AVERTISSEMENT

1. Ne pas entreposer ni utiliser de l'essence ni d'autres vapeurs ou liquides inflammables dans le voisinage de l'appareil, ni de tout autre appareil.
2. Une bouteille de propane qui n'est pas raccordée en vue de son utilisation, ne doit pas être entreposée dans le voisinage de cet appareil ou de tout autre appareil.

THIS GRILL IS FOR OUTDOOR USE ONLY:
If stored indoors, detach and leave L.P. cylinder outdoors.

CE GRIL EST POUR UTILISATION à L'EXTÉRIEUR SEULEMENT:
Si l'appareil est entreposé à l'intérieur, enlever les bouteilles et les laisser à l'extérieur.

BEFORE LIGHTING

1. Read instructions before lighting.
2. Open lid during lighting.
3. If ignition does not occur in 5 seconds, turn the burner control(s) off, wait 5 minutes, and repeat the lighting procedure.

AVANT D'ALLUMER L'APPAREIL

1. Lisez les instructions avant d'allumer l'appareil.
2. Ouvrez le couvercle avant d'allumer l'appareil.
3. Si l'appareil ne s'allume pas en 5 secondes, fermez le robinet du brûleur, attendez 5 minutes, et procédez de nouveau à l'allumage.



GENERAL SAFETY REQUIREMENTS:

1. The installation of this appliance must conform with local codes or, in the absence of local codes, either the *National Fuel Gas Code, ANZI Z223.1/NFPA 54, or CAN/CGA-B149.1, Natural Gas Installation Code or CAN/CGA-B149.2, Propane Installation Code.*
2. This outdoor cooking gas appliance is not intended to be installed in or on recreational vehicles and /or boats.
3. This outdoor cooking gas appliance is intended for use outdoors and shall not be used in a building, garage or any other enclosed area.
4. **Minimum clearance of 12 inches from the back and sides of the grill to adjacent combustible construction must be maintained. This outdoor cooking gas appliance shall not be located under overhead-unprotected combustible construction.**
5. The utilization of an external electrical source requires that when installed, this outdoor cooking gas appliance must be electrically grounded in accordance with the local codes or, in the absence of local codes, with the National Electrical Code, ANSI/NFPA 70, or the Canadian Electrical Code, CSA C22.1. Keep any electrical supply cord, or the rotisserie motor cord and the fuel supply hose away from any heated surfaces.
6. Keep your grill in an area clear and free from combustible materials, gasoline and other flammable vapors and liquids.
7. DO NOT obstruct the flow of combustion and ventilation air to this appliance. Keep the ventilation openings of the cylinder enclosure free and clear from debris.
8. Check all gas connections for leaks with soapy water solution and brush. Never use an open flame. (Reference page 8 for leak test procedure).
9. Check flexible hoses for cuts and wear that may affect the safety before each use.
10. Never use charcoal in the grill.
11. Never use the grill in a windy area.
12. Never use the grill without the drip pan installed and push all the way to the back of the grill. Without the drip pan, hot grease and debris could leak downward and produce a fire hazard.
13. The pressure regulator and hose assembly supplied with the Twin Eagles Gas Grill must be used. Replacement pressure regulators and hose assemblies must be those specified by Twin Eagles.
14. CALIFORNIA PROPOSITION 65-WARNING: The burning of gas cooking fuel generates some by-products which are on the list of substances known by the State of California to cause cancer or reproductive harm. California law requires businesses to warn customers of potential exposure to such substances. To minimize exposure to these substances always operate this unit according to the use and care manual, ensuring you provide good ventilation when cooking with gas.

In Massachusetts: All gas products must be installed using a "Massachusetts" licensed plumber or gasfitter. A "T" handle type manual gas valve must be installed in the gas supply line to this appliance. This applies to permanently installed natural gas and propane installations. This does not apply to propane portable installations using a 20 pound tank.



TABLE OF CONTENTS – TWIN EAGLES GAS GRILL

GETTING STARTED	2
GAS REQUIREMENTS	
○ GAS SAFETY REQUIREMENT.....	4
○ LP GAS HOOKUP.....	5
○ PORTABLE LP CONNECTION.....	6
○ NATURAL GAS INSTALLATION.....	7
○ LEAK TEST.....	8
ELECTRICAL REQUIREMENTS AND ELECTRICAL DIAGRAM	9
WIRING CONNECTION DRAWING DIAGRAM	10
LOCATING THE GRILL	
○ CLEARANCE TO COMBUSTIBLE CONSTRUCTION.....	11
○ CLEARANCE TO NONCOMBUSTIBLE CONSTRUCTION.....	11
CUTOUT DIMENSIONS	
○ INSULATION JACKET.....	12
○ GRILL.....	13
ASSEMBLY INSTRUCTIONS	
○ BRIQUETTE TRAY.....	14
○ SMOKER BOX.....	14
○ WARMING RACK.....	14
○ ROTISSERIE.....	15
OPERATING INSTRUCTIONS	
○ BEFORE LIGHTING THE GRILL.....	16
○ TO LIGHT THE GRILL BURNER	16
○ MATCH LIGHTING INSTRUCTIONS	17
○ USING THE GRILL	17
○ INTERIOR LIGHT OPERATION AND LIGHT BULB REPLACEMENT.....	17
○ USING THE ROTISSERIE BURNER.....	18
○ SEAR ZONE BURNER	18
○ SMOKER BOX.....	18
CLEANING AND MAINTENANCE	
○ STAINLESS STEEL.....	19
○ HEX GRATES.....	19
○ CERAMIC BRIQUETTE TRAY.....	19
○ U-BURNER & SEAR ZONE BURNER.....	20
○ DRIP PAN & SMOKER BOX.....	20
○ SPIDER AND INSECT WARNING.....	20
○ CORRECT BURNER INSTALLATION.....	21
REPLACEMENT PARTS	
○ EXPLODED VIEW.....	22
○ REPLACEMENT PARTS LIST.....	23
○ TROUBLE SHOOTING GUIDE.....	24
○ LIMITED PRODUCT WARRANTY.....	25
○ WARRANTY REGISTRATION CARD	



GETTING STARTED – TWIN EAGLES GAS GRILL

1. Remove all packaging materials, labels and protective plastic film. DO NOT LEAVE UNIT UNDER THE SUN WITH PROTECTIVE PLASTIC FILM ON FOR A LONG PERIOD OF TIME AS IT WILL BE DIFFICULT TO REMOVE THE FILM.
2. Check to ensure that all grill accessories listed below are included.



Grill Accessories	TEBQ 30G	TEBQ 30R	TEBQ 36G	TEBQ 36R	TEBQ 42G	TEBQ 42R
Basting Pan		1		1		1
Hex Grate, Stainless Steel	2	2	3	3	3	3
Large Briquette Tray Assy. (Standard Grill)	1	1	2	2	2	2
Large Briquette Tray Assy. (Grill w/ Sear Zone)			1	1	1	1
Small Briquette Tray Assy. (Standard Grill)	2	2	2	2	2	2
Small Briquette Tray Assy. (Grill w/ Sear Zone)	2	2	2	2	2	2
Rotisserie Motor with bracket (s/s)		1		1		1
Regulator, NG (NG Grill ONLY)	PRE-INSTALLED					
Regulator, LP (LP Grill ONLY)	1	1	1	1	1	1
Warming Rack, (s/s)	1	1	1	1	1	1
Spit Rod, (s/s)		1		1		1
Meat Holder Forks (pair) (s/s)		1		1		1
Smoker Box Assy.	1	1	1	1	1	1

3. Assemble parts as per assembly instructions on page 14-15.
4. Fill up the Warranty Registration Card and mail it to the indicated address.

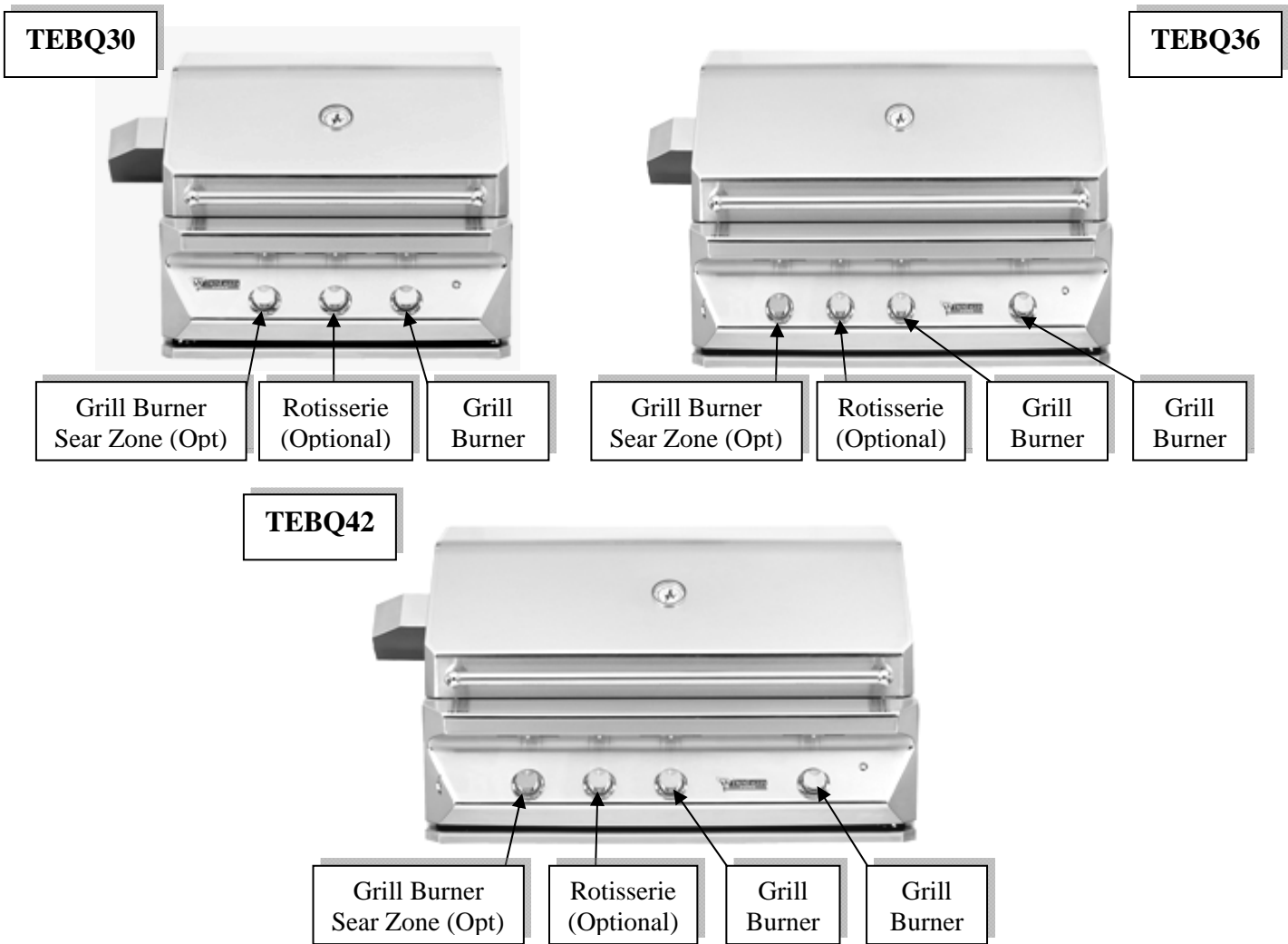

5. Get familiar with the knobs and burners identification below.

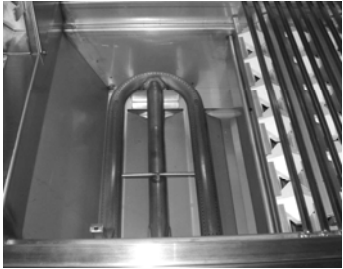
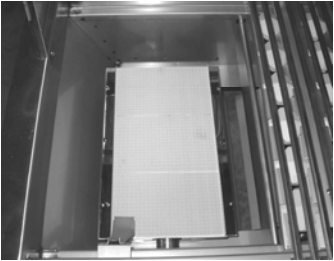

		
<p>Grill U-Burner (Standard) located underneath the briquette trays.</p>	<p>Sear Zone Burner (Optional) usually located on the left side.</p>	<p>Infrared Rotisserie Burner (Optional) located on the rear panel above the hex-grates.</p>



GAS SAFETY REQUIREMENTS – TWIN EAGLES GAS GRILL

Each appliance is set and tested at the factory for the type of gas supply to be used. Identify the type of gas, either natural gas or LP gas and make sure that the marking on the data plate (rating plate) matches the gas being supplied to the grill. The data plate is located on the panel behind the control panel of the grill. Remove the drip pan to visually access the nameplate label from the front of the grill. A second label with model number and serial number is located under the right side of the control panel.

All gas connections should be made by a qualified technician and in accordance with local codes and ordinances. The installation must conform with local codes or, in the absence of local codes, with either the national Fuel Gas Code, ANSI Z223.1/NFPA 54, or CAN/CGA-B149.1, Natural Gas Installation Code or CAN/CGA-B149.2, Propane Installation Code.

WARNING:

CHECK TO ENSURE THAT THE GAS SUPPLY HOSE DOES NOT COME IN CONTACT WITH ANY HOT SURFACE OF THE GRILL.

NEVER CONNECT THE GRILL TO AN UNREGULATED GAS SUPPLY.

L.P. GAS (LIQUIFIED PETROLEUM /PROPANE)

If your grill is factory built for L.P., the regulator supplied is set for 11” water column and is for use with L.P. gas only. The factory-supplied regulator and hose must be used with a 20 lb. L.P. cylinder.

L.P. GAS SAFETY REQUIREMENT

The LP-gas supply cylinder must be constructed and marked in accordance with the *Specifications for LP-gas Cylinders* of the U.S. Department of Transportation (D.O.T.) or the National Standards of Canada *CAN/CSA-B339, Cylinders, Spheres and Tubes for the Transportation of Dangerous Goods, and Commission*, as applicable; and

1. Provided with a listed overfilling prevention device.
2. Provided with a cylinder connection device compatible with the connection for outdoor cooking appliances.

It must be provided with a shut-off valve terminating in gas tank valve outlet. It must include a collar to protect the cylinder valve. The cylinder supply system must be arranged for vapor withdrawal.

Do not operate the gas grill indoors or in any enclosed area. If the gas grill is not in use, the gas must be turned off at the supply cylinder. If the grill is to be stored indoors, disconnect the gas supply cylinder and leave the cylinder outdoors.



LP GAS HOOK-UP – TWIN EAGLES GAS GRILL

Install the factory-supplied hose and regulator assembly as shown. Connect the $\frac{3}{8}$ " flare end of the hose to the grill coupling using a $\frac{3}{4}$ " open wrench. Do not apply pipe sealant to the $\frac{3}{8}$ " flare connection. Connect the regulator to the LP cylinder hand tighten it, do not use a wrench. Check for leaks using soapy water solution. (Reference page 7 for leak test procedure).

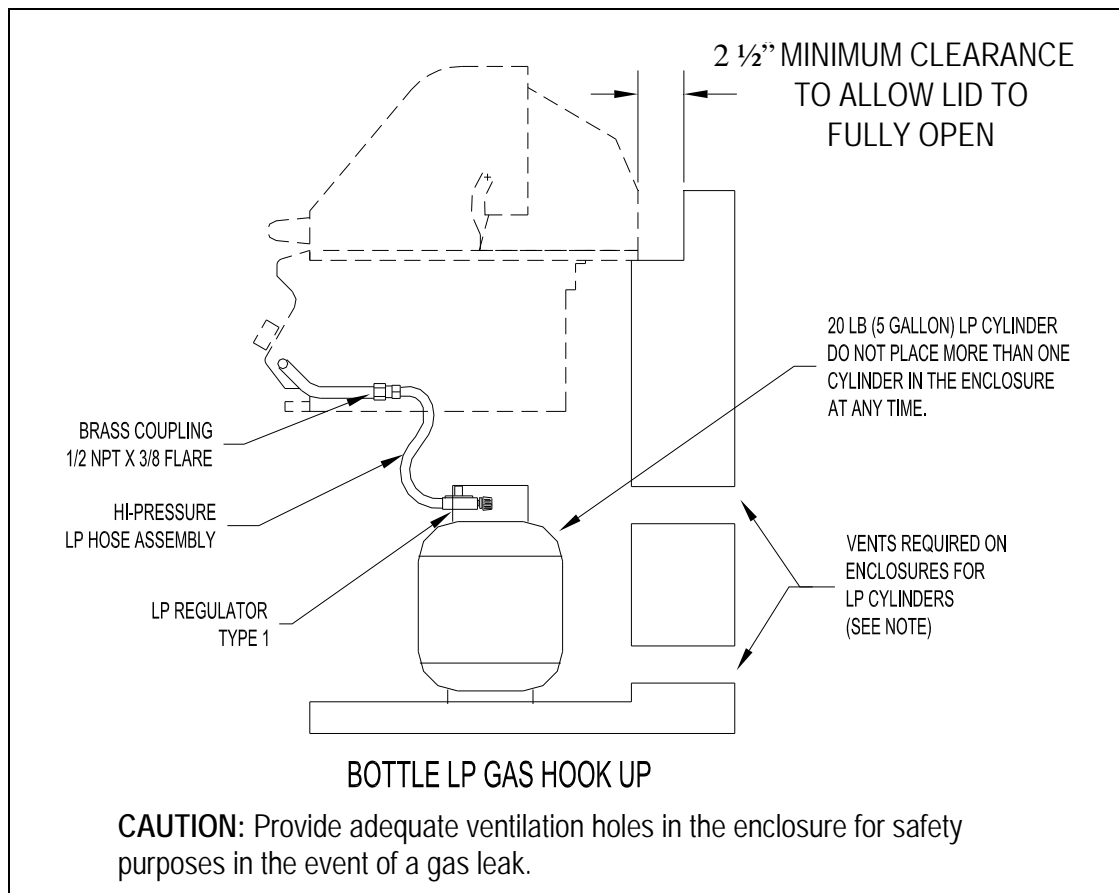

Note: An enclosure for LP gas cylinder must be vented on the level of the cylinder valve and at floor level. The effectiveness of the opening(s) for purposes of ventilation shall be determined with the LP gas supply cylinder in place. This shall be accomplished by one of the following:

- a. One side of the enclosure shall be fully open; or
- b. For an enclosure having four sides, a top and a bottom:
 1. At least two ventilation openings at cylinder valve level shall be provided in the sidewall, equally sized, spaced at 180 degrees (3.14 rad), and unobstructed. Each opening shall have a total free area of not less than $\frac{1}{2}$ square inch per pound ($7.1 \text{ cm}^2/\text{kg}$) of stored fuel capacity and not less than a total free area of 10 square inches (64.5 cm^2).

Ventilation opening(s) shall be provided at floor level and shall have a total free area of not less than $\frac{1}{2}$ " square inch per pound ($7.1 \text{ cm}^2/\text{kg}$) of stored fuel capacity and not less than a total free area of 10 square inches (64.5 cm^2). If ventilation openings at floor level are in a sidewall, there shall be at least two openings. The bottom of the openings shall be at floor level and the upper edge no more than 5 inches (127 mm) above the floor. The openings shall be equally sized, spaced at 180 degrees (3.14 rad) and unobstructed.



PORTABLE LP CONNECTION – TWIN EAGLES GAS GRILL

One of the many features of the TWIN EAGLES grill base is the pullout slide pan for easy access to the LP gas tank.

- **NOTE:** Use only a 20-lbs. (5 gallon capacity) gas cylinder.
- **WARNING: DO NOT PLACE MORE THAN ONE CYLINDER IN THE BASE CABINET ENCLOSURE AT ANY TIME.**
- **WARNING: DO NOT USE A DENTED OR RUSTED LP CYLINDER.**
- **NEVER USE A CYLINDER WITH A DAMAGED VALVE.**

- **ALWAYS CHECK FOR LEAKS AFTER CHANGING THE LP CYLINDER.**

- **THE LP PRESSURE REGULATOR AND HOSE SUPPLIED WITH THIS UNIT MUST BE USED WITHOUT ALTERATION.**

CAUTION: USE EASY PULL. Use the slot at the front of the pan to push or pull out the gas cylinder. Do not place hand on the top of the gas cylinder when pushing or pulling the slide pan.



- 1) To install the gas cylinder, pull out the slide pan and place the cylinder onto the pan.
- 2) Check to ensure that the tank's gas valve on top of the cylinder is closed.
- 3) Connect the LP regulator (included) to the cylinder and hand-tighten only. Open the tank valve and make sure all connections are leak tight using a soapy water solution and a brush. (Reference page 7 for leak test procedure).



NATURAL GAS INSTALLATION – TWIN EAGLES GAS GRILL

The installation must conform with local codes or, in the absence of local codes, with either the national Fuel Gas Code, ANSI Z223.1/NFPA 54, or CAN/CGA-B149.1, Natural Gas Installation Code or CAN/CGA-B149.2, Propane Installation Code.

1. This gas appliance and its individual shutoff valve must be disconnected from the gas supply piping system during any pressure testing of that system at the test pressures in excess of 1/2 psi (3.5 kPa).
2. This appliance must be isolated from the gas supply piping system by closing its individual manual shutoff valve during any pressure testing of the gas supply piping system at test pressures equal to or less than 1/2 psi (3.5 kPa).

If the gas grill is factory built for natural gas, the regulator supplied is set for 4" water column. The regulator is convertible to 10" water column for system LP application. Do not use with a 20-lb LP cylinder. Make sure that the regulator is set for natural gas. To check, remove the brass hex cap. You will find the conversion plastic pin attached to the underside of the cap. If the disc (1/2 in. diameter) of the pin is close to the cap, then the regulator is set for natural gas. If the disc is at the tip of the pin, away from the brass cap, the regulator is set for system LP application. To convert to natural gas, remove the plastic conversion pin and invert and replace it back in a manner such that the disc is close to the brass cap. For both natural and LP, the maximum inlet pressure is 14" water column.

A typical natural gas installation is shown below. Make sure that the factory-supplied regulator is used and installed with the arrow mark on the regulator pointing towards the gas grill. Do not use any replacement regulator other than that specified by Twin Eagles. Use only pipe sealants that are approved for use with natural and LP gases. An installer-supplied gas shutoff valve must be installed in an accessible location.

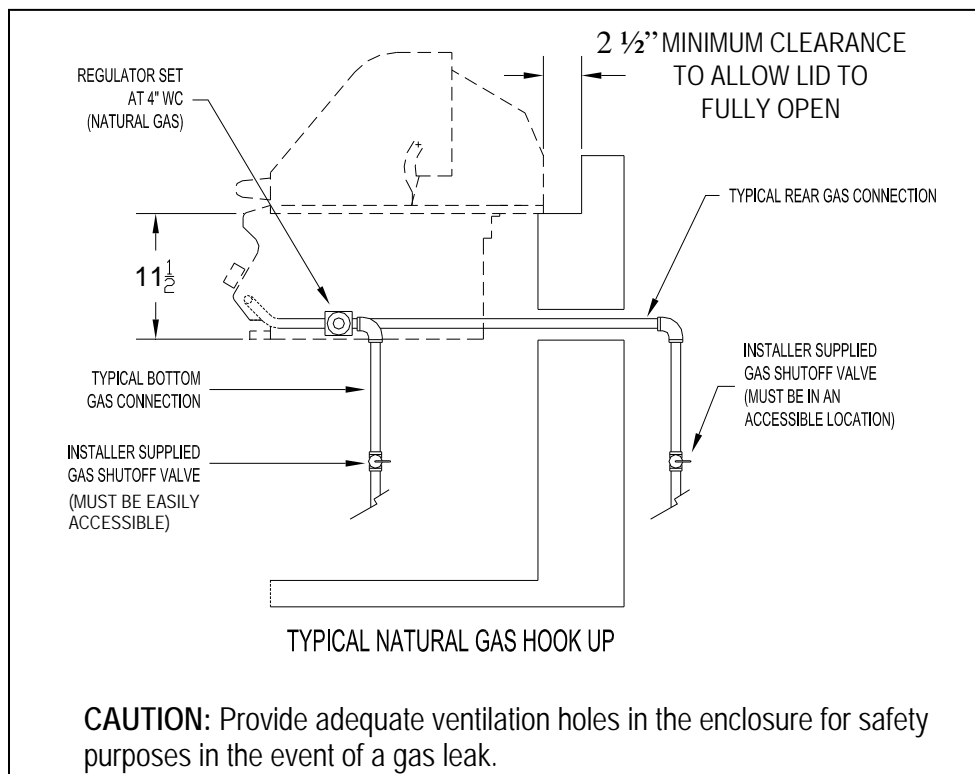

LEAK TEST – TWIN EAGLES GAS GRILL

CAUTION BEFORE TESTING

- Finding and/or fixing a gas leak is NOT a “DO-IT-YOURSELF” procedure.
- NEVER USE THE GRILL WITHOUT FIRST LEAK TESTING THE GAS CONNECTIONS.
- WARNING: DO NOT USE OPEN FLAME TO CHECK FOR LEAKS. USE OF AN OPEN FLAME COULD RESULT IN A FIRE, EXPLOSION AND BODILY HARM.
- DO NOT SMOKE WHILE PERFORMING THE LEAK TEST!
- To prevent fire or explosion hazard, DO NOT use or permit sources of ignition in the area while performing a leak test. Perform leak test outdoors only.
- Check to ensure that flexible hoses do not have any cuts and wear that may affect the safety before each use. Only the factory supplied hose and regulator must be used. Use only replacement regulator and hose assemblies specified by Twin Eagles.

LEAK TEST

- 1) Prepare a leak testing solution of sudsy water by mixing in a spray bottle with half liquid soap and half water.
- 2) Confirm that all control knobs are in the OFF position.
- 3) Turn the main gas valve supply ON.
- 4) Apply leak testing solution by spraying on the pipe joints, fittings, and hose.
- 5) A gas leak is detected if;
 - a) there is a faint gas smell and/or...
 - b) ...growing bubbles appear on any of the connection points and/or hose, DO NOT attempt to ignite the grill and IMMEDIATELY turn off the gas supply valve.
- 6) When there is a gas leak, call a qualified service technician. DO NOT use the grill until the leak is corrected.

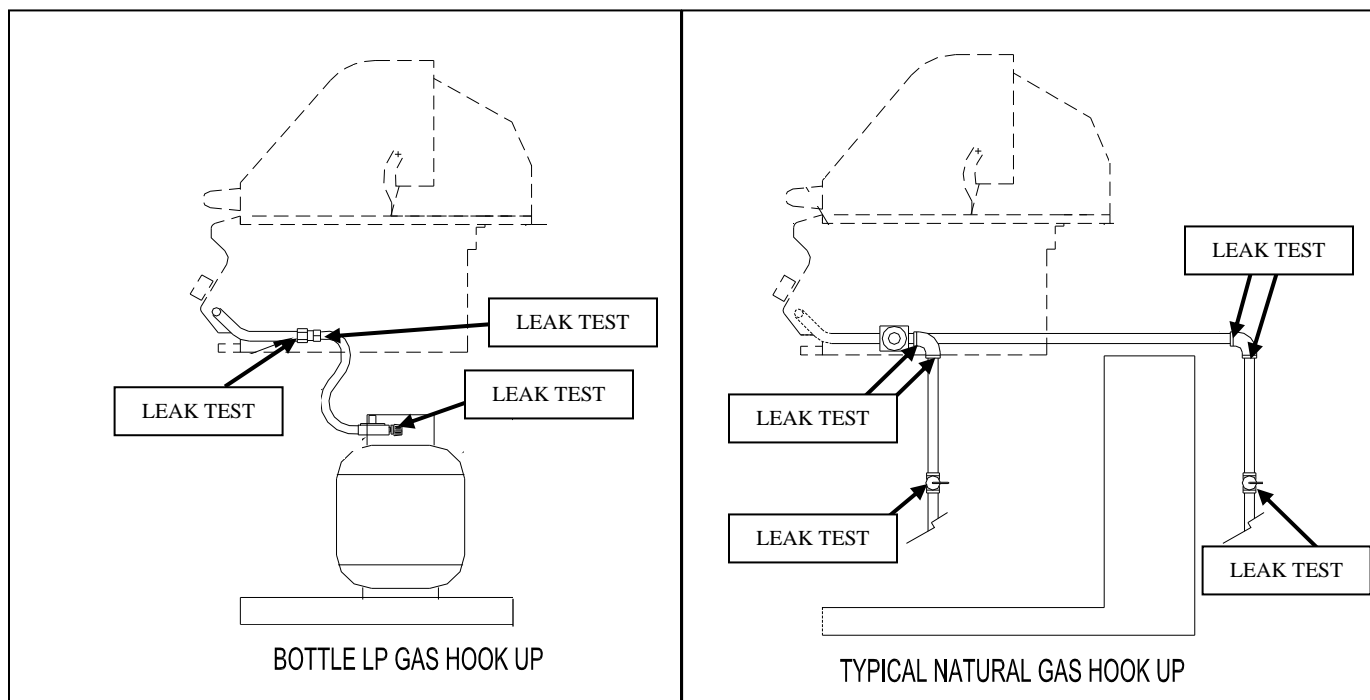

ELECTRICAL REQUIREMENTS – TWIN EAGLES GAS GRILL

TO INSTALL AND SECURE POWER TRANSFORMER

Grill models with interior lights have a power transformer which is concealed in a stainless steel box with an attached power supply cord. This transformer must be secured in a dry location and away from the grill firebox and excessive heat area.

1a. In a base cart application, two mounting screws with nuts are provided at the bottom right rear corner of the cart. If not provided, drill two holes using the transformer box as a template.

Secure the transformer box as shown.

1b. In an island application secure the transformer box near the GFCI 120V outlet in a dry location and away from the grill firebox and excessive heat area.

2a. Make the transformer connections to the wire harness located at the right rear of the grill to the harness of the transformer box.

2b. Plug-in the transformer's power cord to the properly grounded GFCI 120V outlet.

ROTISSERIE MOTOR:

The rotisserie motor requires 120 volt supply. The power supply cord on the motor is equipped with a 3-prong (grounded) plug for protection against shock hazard. Do not cut or remove the grounding prong from the plug.

WARNING

Electrical Grounding Instructions:
This outdoor gas cooking appliance is equipped with a three prong (grounding) plug for your protection against shock hazard and should be plugged directly into a properly grounded three prong outlet. Do not cut or remove the third prong from this plug.

AVERTISSEMENT

Instruction pour la mise à la terre électrique:
Cet appareil est muni d'une fiche à trois broches (mise à la terre) afin de vous protéger des chocs et doit être branché directement dans une prise de courant à trois broches adéquatement mise à la terre. Il ne faut pas couper ou enlever la broche de mise à la terre de cette fiche.



1a.



2a.

1b.

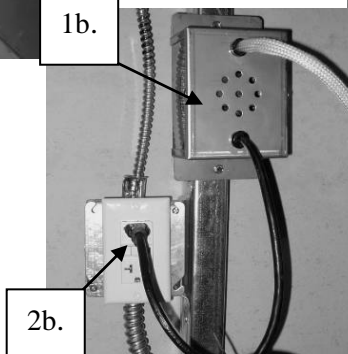

2b.





WIRING CONNECTION DIAGRAM

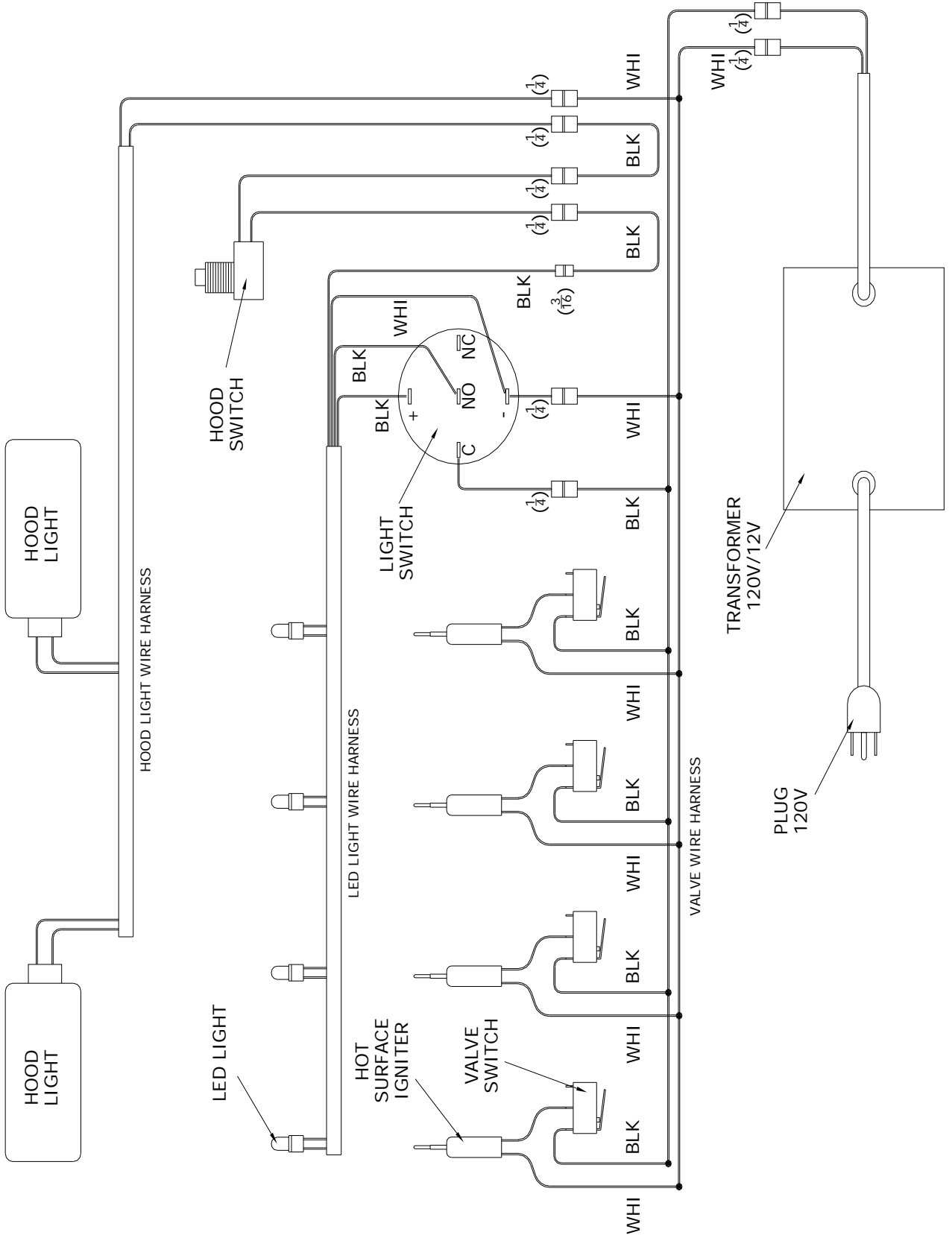

LOCATING THE GRILL – TWIN EAGLES GAS GRILL

This gas appliance is design and certified for outdoor use only. Do not locate this grill under overhead combustible surfaces. Do not operate the grill inside a building, garage, recreation vehicle or any enclosed area. When choosing an area, consider exposure to wind, proximity to traffic paths and length of gas supply line. Keep gas supply lines as short as possible to reduce pressure drop. Keep the grill away from windy area but keep the grill in a well-ventilated area. Do not obstruct the flow of combustion and ventilation air around the grill. The supporting edges of the grill must be located level and flat. The counter should also be leveled.

CLEARANCE TO COMBUSTIBLE CONSTRUCTION

A minimum clearance of 12” from the sides and 12” from the back of the grill to adjacent vertical combustible construction must be maintained.

DÉGAGEMENT DE TOUTE CONSTRUCTION COMBUSTIBLE

Il faut maintenir une distance minimum de 12 po (30.48 cm) sur les côtés et de 12 po (30.48 cm) sur l'arrière du gril par rapport aux constructions combustibles verticales adjacentes.

CLEARANCE TO NONCOMBUSTIBLE CONSTRUCTION

A minimum clearance of 2 ½” from the back of the grill above cooking surface to non-combustible construction is required to allow the grill hood to open completely.

A minimum of 6” clearance to the sides of the grill above cooking surface to non-combustible construction is recommended to provide space for the rotisserie motor and the spit rod. The grill can be installed directly next to non-combustible construction below the cooking surface.

DÉGAGEMENT DE TOUTE CONSTRUCTION INCOMBUSTIBLE

Une distance minimum de 2 ½ po (6.25 cm) de l'arrière du gril au-dessus de toute surface de cuisson à la construction incombustible est prescrite pour permettre à la hotte d'ouvrir complètement. Une distance minimum de 6 po (15.24 cm) des côtés du gril au-dessus de la surface de cuisson à la construction incombustible est recommandée pour prévoir de l'espace pour le moteur de la rôtissoire et la poignée des broches de cuisson. Le gril peut être installé directement à proximité d'une construction incombustible en-dessous de la surface de cuisson.



INSULATION JACKET CUT-OUT DIMENSIONS – TWIN EAGLES GAS GRILL

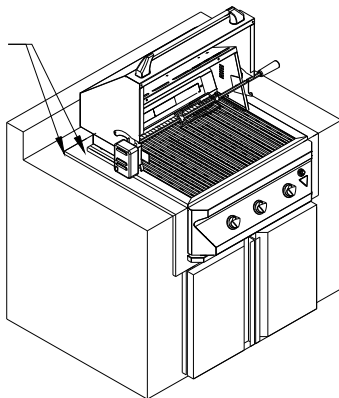
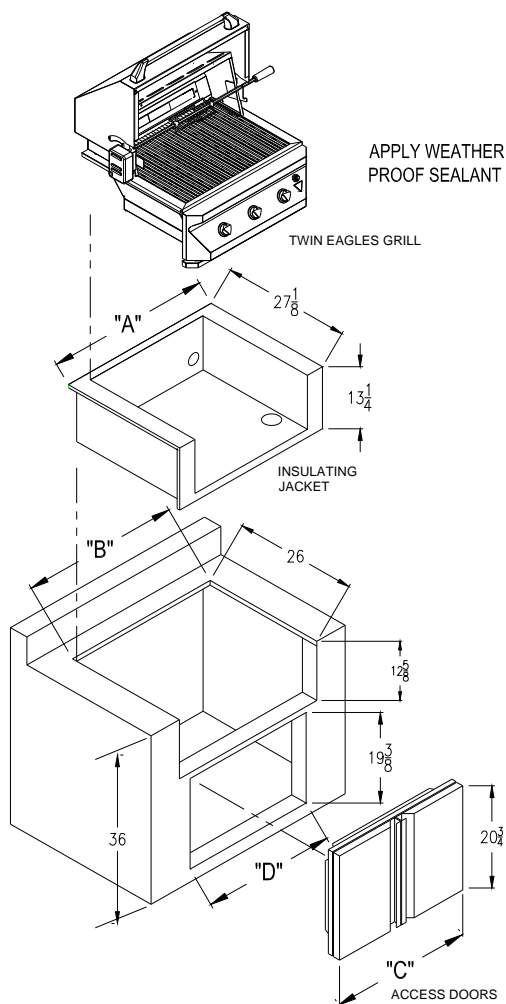

INSULATING JACKET

MODEL	"A"	"B"
TEIJ-30	34 3/4"	33 1/2"
TEIJ-36	40 3/4"	39 1/2"
TEIJ-42	46 3/4"	45 1/2"

ACCESS DOORS

MODEL	"C"	"D"
TEAD-30	30"	28 1/4"
TEAD-36	36"	34 1/4"
TEAD-42	42"	40 1/4"

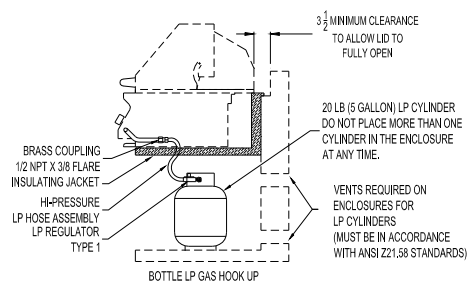
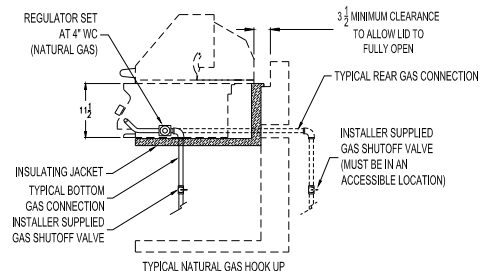

INSULATING JACKET INSTALLATION TWIN EAGLES OUTDOOR GRILLS

INSULATING JACKET

WARNING:

Do not build the grill under overhead unprotected combustible construction. If the grill is to be placed into combustible enclosure, an approved insulating jacket is necessary to prevent fire, property damage and bodily injury. Use only Twin Eagles insulating jacket. Refer to next page for cut-out dimensions.

IMPORTANT:

Do not install the transformer box inside the insulating jacket (TEIJ). The transformer box must be secured away from excessive heat and in a dry location.



GRILL CUT-OUT DIMENSIONS – TWIN EAGLES GAS GRILL

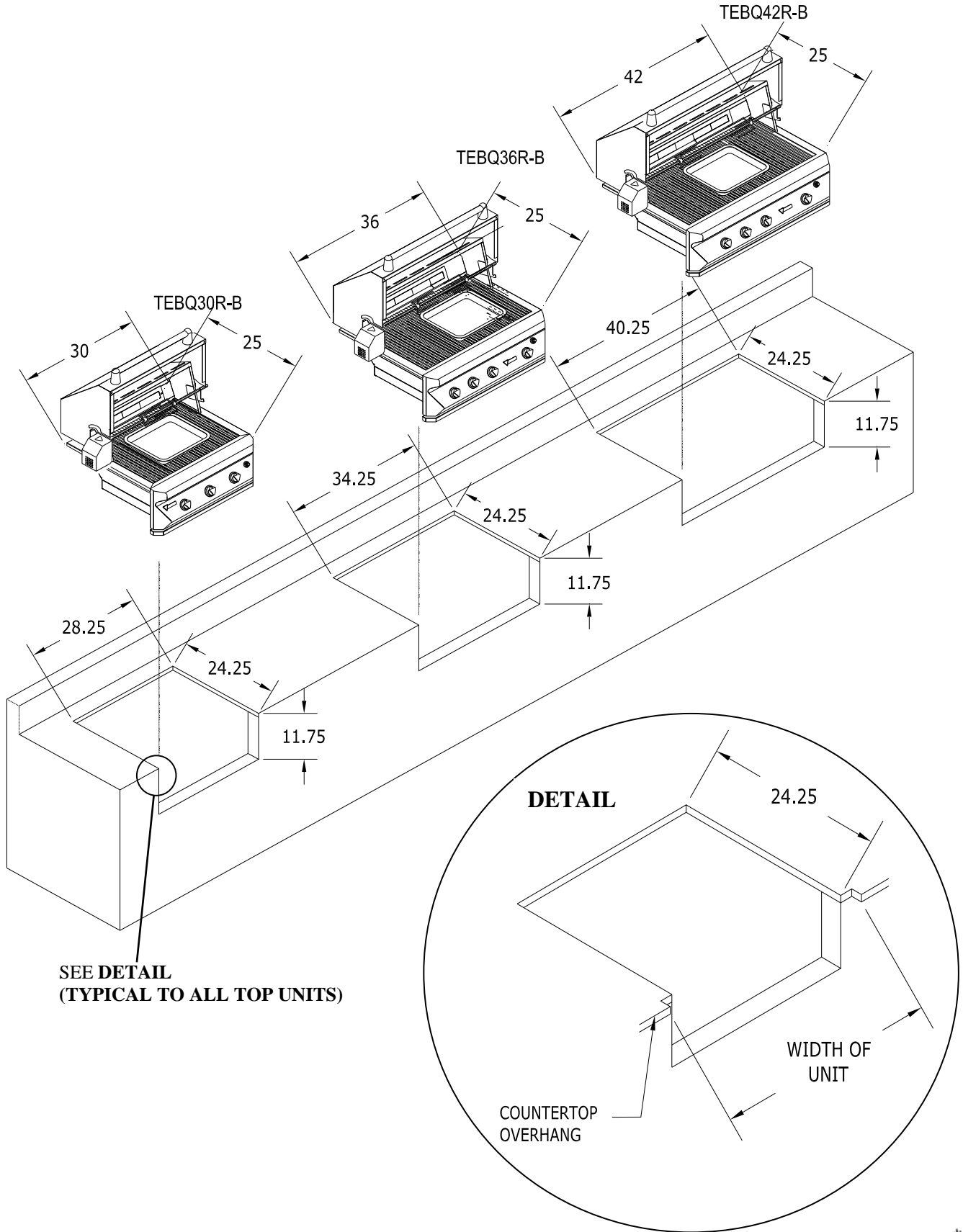

ASSEMBLY INSTRUCTIONS – TWIN EAGLES GAS GRILL

The TWIN EAGLES Grill is produced fully assembled and tested in the factory and requires no major assembly in the field. For the purpose of safe shipping and transit, some parts such as the briquette trays and rotisserie components are wrapped inside the grill and require minor assembly.

Check to ensure that all packaging material have been removed prior to grill operation.

TO INSTALL BRIQUETTES TRAYS

1. Put briquette trays into the grill above the burner, as shown by placing the flash-tube-hole on the front.
2. Place the hexagonal grates directly above the briquette trays and make sure the square openings on the grates are at the front.



TO INSTALL AND USE THE SMOKER BOX

1. Lift open smoker box lid and add smoking chips with water.
2. Remove a hex grate. Remove a ½ sized briquette tray where there is no flash tube.
3. Place the smoker box in place of the briquette tray and the smoker box will always line-up on top of the burner flame. Place hex grate back on. Turn on grill to HIGH heat. Once smoking starts, turn the heat down to prevent wood flare-up. Smoker box is standard on all grills.



WARMING RACK LEVEL POSITIONS:

The warming rack may be used at a HI and LOW level position. The HI level is further away from the heat source while the lower level position is closer to the heat source.

When the warming rack is not in use, it may be moved out of the way by moving up to the top support hooks.



ROTISSERIE ASSEMBLY

For Larger Loads

1. Install the rotisserie motor horizontally as shown. The motor socket hole will line up with the lower notch of the spit saddles.
2. Insert the rotisserie-rod into the motor socket hole and place the rod on the lower notch of each spit saddle.
3. Remove the hexagonal grates.
4. Place the basting pan on top of the briquette trays to catch the drippings.



For Smaller Loads

1. Install the rotisserie motor vertically as shown. The motor socket hole will line up with the upper notch of the spit saddles.
2. Insert the rotisserie-rod into the motor socket hole and place the rod on the upper notch of each spit saddle.
Place a basting pan on top of the hexagonal grates to catch the drippings.



OPERATING INSTRUCTIONS – TWIN EAGLES GAS GRILL

BEFORE LIGHTING THE GRILL

- **DO NOT ATTEMPT TO LIGHT THE GRILL IF YOU SMELL GAS.**
- **WARNING! IT IS CRITICAL THAT THE GAS BURNERS ARE PROPERLY INSTALLED WITH THEIR ORIFICES INSIDE THE BURNERS AIR SHUTTERS.** If not properly installed, gas may leak outside of the burner that could lead to fire, potential damage to your grill and bodily injury.
- Inspect the gas supply piping or hose prior to turning the gas ON. If there is evidence of cuts, wear, or abrasion, it must be replaced prior to use. The replacement pressure regulator and hose assembly must be the type specified by the manufacturer. Do not use the grill if the odor of gas is present. The pressure regulator and hose assembly supplied with the units must be used.
- If the unit is LP, screw the regulator and hand tighten to the valve of the cylinder and leak check the hose and regulator connections with a soap and water solution before operating the grill. Reference page 7 for leak test procedure.
- Always keep your face and body as far away as possible when lighting.
- Refer to spiders and insects warning and procedure under the cleaning and maintenance page of this manual.

TO LIGHT THE GRILL BURNER

Lighting the Grill

1. Open the grill hood completely. Do not attempt to light the grill with the hood closed.
2. Open the gas supply shut-off valve.
3. Push in the knob and verify that the hot surface igniter glows. The hot surface igniters are located inside the flashtubes and on the rear panel next to the rotisserie burner, (if equipped). If the igniter does not glow, verify for proper power supply. (Reference page 8 for electrical requirements).
4. Once the glowing is verified simultaneously push-in and turn the knob counter-clock-wise to the biggest flame marking on the bezel. Hold the knob pushed in for 5 seconds. Once you see or hear a flame you can release the knob.

CAUTION: If ignition does not take place within 5 seconds, turn knob to the OFF position, wait for five minutes and repeat step 6.

5. Close the hood to allow the grill to pre-heat until the hood thermometer displays the desired grilling temperature.

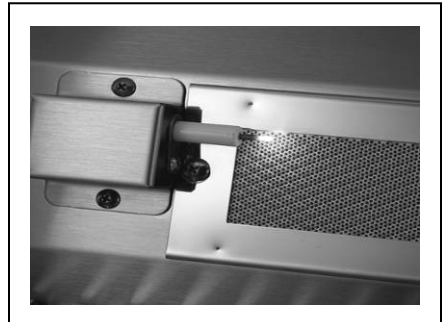

Match/BBQ Lighter Lighting Instructions:

If there is no electrical power supply available or if hot surface igniter will not light the burners, the burners can be lit manually using a lighted long match, taper or BBQ lighter.

1. Push and turn the knob counter-clock-wise to the biggest flame marking on the bezel. Hold the knob pushed in for 5 seconds.
2. Insert a lit match or BBQ lighter thru the hex grates and near the top of the flashtube. Once you see or hear a flame you can release the knob.

Important: If burner fails to light within 5 seconds, turn off gas and wait 5 minutes before repeating the process.

Warning: If you smell gas, shutoff the gas supply and immediately check for leaks using the soapy water technique.

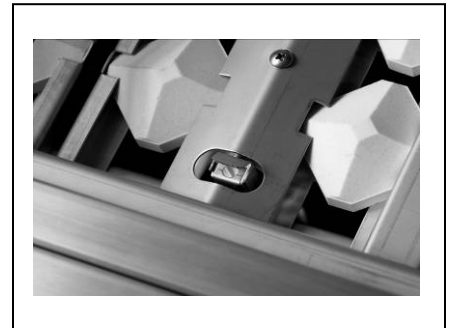
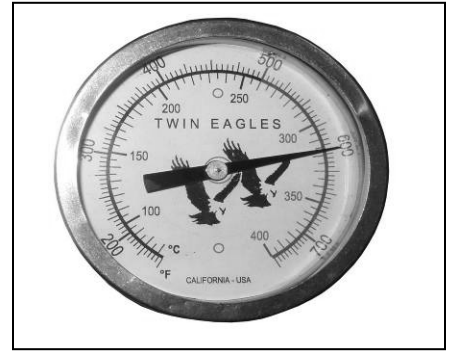

USING THE GRILL

1. Check to be certain that the drip pan is in place and pushed all the way into the grill.
2. Light the grill burners using the instructions in use and care manual.
3. Turn the control knobs to HI and allow the grill to preheat for 15 minutes or until desired temperature is displayed on the thermometer. The top cover is to be closed during the appliance preheat period.
4. Place the food on the grill and cook to the desired temperature doneness. Adjust heat setting, if necessary. The control knob may be set to any position between HI and LO.
5. Allow grill to cool and clean the drip pan after each use.

INTERIOR LIGHT OPERATION

The TWIN EAGLES grill is equipped with two interior halogen lights and decorative knob lights for late night grilling. The grill is equipped with a switch that allows the interior lights to shut-off automatically when closing the hood without turning off the knob lights.

1. Push the switch located on the front panel to turn ON interior and knob lights.
WARNING: Do not touch the interior halogen lights. It may be hot and can cause serious burns.

REPLACING INTERIOR LIGHT BULBS

WARNING! Unplug the grill from the 120V power source before replacing the light bulb.

1. Remove the screw that holds the lens cover and slide the lens cover out.
2. Remove the old light bulb by pulling it straight out of the socket without twisting the light bulb.
3. Wearing plastic gloves, insert the new light bulb into the socket. **DO NOT** touch bulb with bare hands as the oil and dirt will shorten bulb life.
4. Slide the light lens back into the light assembly and screw it to secure it.



USING THE ROTISSERIE BURNER

The Rotisserie system rotates the food in front of infrared burner heat for even cooking and juicier taste.

1. Install the rotisserie motor on the motor bracket and plug it in to proper voltage. Reference electrical requirements.
2. Insert the food on the middle of the spit rod and then secure it with the meat holders on both ends by tightening the thumb screws on the meat forks. If multiple pieces of food will be cooked at the same time, make sure the load is evenly balanced on the spit rod. Proper weight balancing will lead to evenness of cooking and prolong the life of the rotisserie motor.
3. Insert the spit rod in the rotisserie motor at desired cooking position. You may need to remove the cooking grates to create clearance for bigger loads of foods. Reference assembly instructions for rotisserie assembly instructions.
4. Always use the basting pan beneath the food to catch drippings and prevent them from falling on the burners and briquette trays.
5. Locate the rotisserie knob which is the second knob from the left.
6. Push-in and turn the knob counter-clock-wise to the biggest flame marking on the bezel. Hold the knob pushed in for 5 seconds. Once you see or hear a flame you can release the knob.
7. Once lit, the rotisserie burner will reach cooking temperature in about 1 minute.
CAUTION: If ignition does not take place within 5 seconds, turn knob to the OFF position, wait for five minutes and repeat step 6.
8. Once cooking is completed, shut-off the rotisserie burner and main valve.

WARNING: When using the rotisserie always keep the front hood closed except when basting or checking the meat for cooking completion. It is recommended to use a meat thermometer to check if the food is completely cooked.

CAUTION: In sunny or heavy light environments, the flame from the infrared rotisserie burner may be difficult to see and verify complete ignition.

NOTE: The rotisserie motor must be stored in an area secured from the surrounding elements when not in use. Do not leave it mounted on the grill.

SEAR ZONE

Searing steaks and other meats with infrared sear burner at the beginning of the grilling cycle helps lock in juices and flavor. Sear the meats quickly with the front hood open, followed by regular grilling over the U-burner.

CAUTION

Never allow liquids to come in contact with the Infrared Sear Zone burner since it could cause damage to the ceramic tiles. **DO NOT** place briquette tray over sear burner. This will block the infrared heat and will damage the tray.

SMOKER BOX

The Twin Eagles sealed smoker box can hold dry wood chips or liquids for hickory, mesquite or your favorite wood chips to give meat a smoky flavor.

- 1) Remove a grate.
- 2) Remove a half size briquette tray where there is no flashtube and replace it with the smoker box.
- 3) Add water and your favorite wood chips.
- 4) Wait for the chips to start smoking and you are ready to start grilling.

WARNING: Never use the smoker box over the Sear Zone burner



CLEANING & MAINTENANCE – TWIN EAGLES GAS GRILL

STAINLESS STEEL

The TWIN EAGLES grill is made of all welded stainless steel. It is non-rusting and non-magnetic. Never clean the stainless steel when it is hot. After the initial grilling use, certain areas of the grill may discolor. This is a normal discoloration caused by the intense heat given off by the burners. Specks of grease can gather on the surface of the stainless steel and get baked-on. These can be removed by using a mild abrasive pad (like Scotch Brite) with a stainless steel cleaner. Use the mildest cleaner and always scrub in the direction of the grain.

Do not use steel wool to clean the grill. Do not use abrasives on the polished highlights. Be extra careful when cleaning around the highlights. Metal polisher or mild chrome cleaner can be used to bring back the luster on highlights. To touch-up minor scratches in the stainless steel, sand the affected surface very lightly, with 100-dry grit emery sandpaper in the direction of the grain.

HEX GRATES

The easiest way to clean the hex grates is to scrub them with a barbecue brush immediately after cooking is completed and the flame is turned off.

Wear a barbecue mitt to protect your hands from the heat and steam. Dip a brass bristle barbecue brush in tap water and scrub the hot grill. Dip the brush frequently in tap water. Steam, created as water comes in contact with the hot grill, helps loosen food particles stuck in the grill. These food particles will either get burned into the briquettes or fall into the cleaning pan. Cleaning of the grill would be longer and more difficult if the grill racks are allowed to cool before cleaning. When cleaning the grates make sure to not hit the rotisserie burner.



CERAMIC BRIQUETTE TRAY

It is not necessary to remove and clean the briquettes from the tray after every grilling. They burn themselves clean during the next cooking operation. If desired, you can burn them clean by lighting the grill and letting it burn on high for about 30 minutes with the briquette tray upside down. Periodically, the briquette trays need to be cleaned. Remove them from the grill, shake free loose of the debris and wipe the trays clean. Do not handle a hot briquette tray.

REPLACING BRIQUETTE TRAYS

- 1) Remove the screws that hold the trim.
- 2) Remove the old briquettes and place the new briquettes on the same location as the old ones.
- 3) Place the trim with the flash-tube-hole on the trim on the same side as the flash-tube-hole on the tray.

CAUTION

DO NOT place briquette trays over the infrared sear zone burner. This will block the infrared heat and will cause damage to the tray.

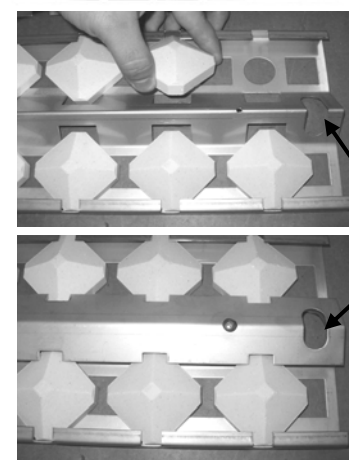
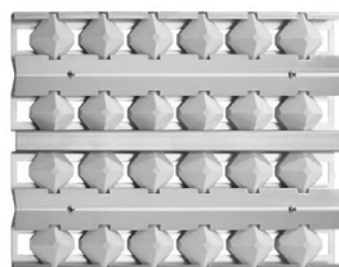

Flash tube hole.



BURNERS

Burners are made of heavy gauge stainless steel and can be soaked in water and cleaned with wire brush. Check every port hole for clogs. Use a wire pin to clean out clogged ports. Make sure the burner is dry before installing it back to the grill.

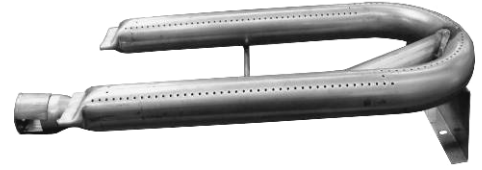

INFRARED SEAR ZONE BURNER

The infrared burner has stainless housing and protective screen. The protective screen helps reflect heat up to the cooking surface and also catches any food particles from landing on the ceramic burner. At the searing temperatures that the burner reaches all food particles will be burned off so the only maintenance required is to cleaning the protective screen and checking for any objects that may be trapped.

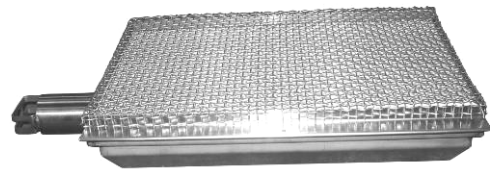

DRIP PAN

The drip pan collects grease, liquid and fallen food particles. Allow the pan and its contents to cool before cleaning. Slide the pan out and wipe it clean. Make sure the drip pan is fully inserted back into the grill. It is highly recommended to clean the pan after every use to avoid any possibility of a grease fire. **DO NOT** use the grill without the drip pan pushed all the way to the back of the grill unit.



SMOKER BOX

The smoker box is a component that can be easily removed from the grill for cleaning. The lid easily comes off for easy cleaning.



SPIDER AND INSECT WARNING

Spiders and other insects can nest in the burners of this and any other grills, which causes the gas to flow from the front of the burner. This dangerous “condition” can cause a fire behind the valve panel, damaging the grill and making the grill unsafe to operate. Inspect the burners once a year or if the grill has not been used for more than one month or if any of the following conditions occur:

- 1) The smell of gas in conjunction with the burner flames appearing yellow.
- 2) The grill does not reach temperature.
- 3) The grill heats unevenly.
- 4) The burners make popping noises.



Correct Burner Installation

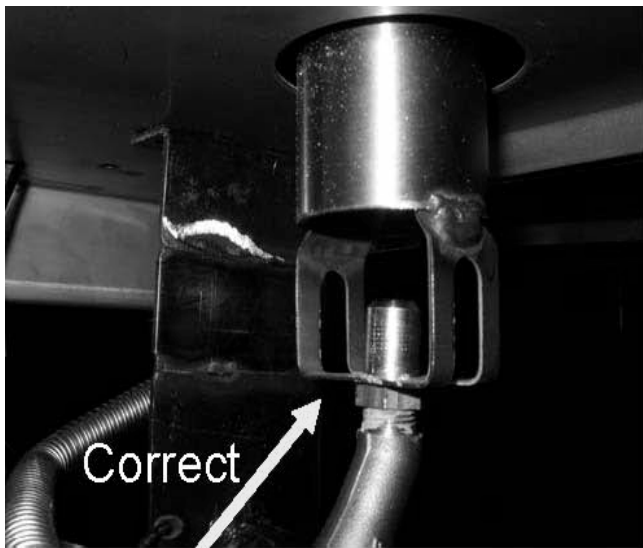

The gas valve orifice is completely inserted inside the burner venturi

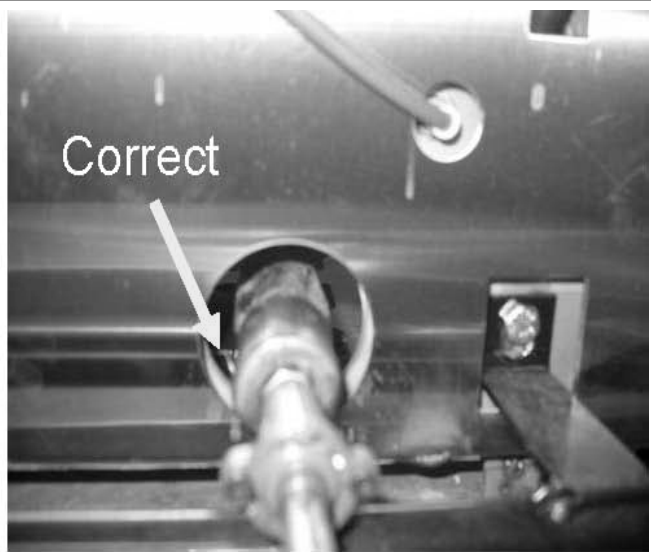

The gas valve orifice is out of position and is not inserted into the burner

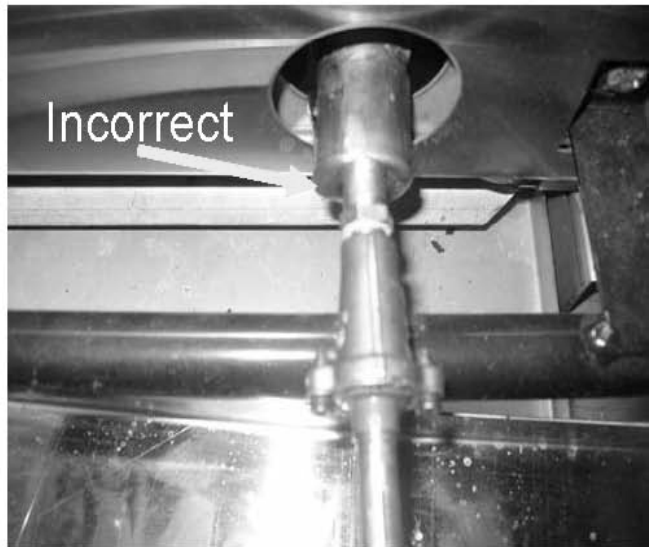

The orifice is out of position, the orifice is touching the tip of the burner venturi



EXPLODED VIEW – TWIN EAGLES GAS GRILL

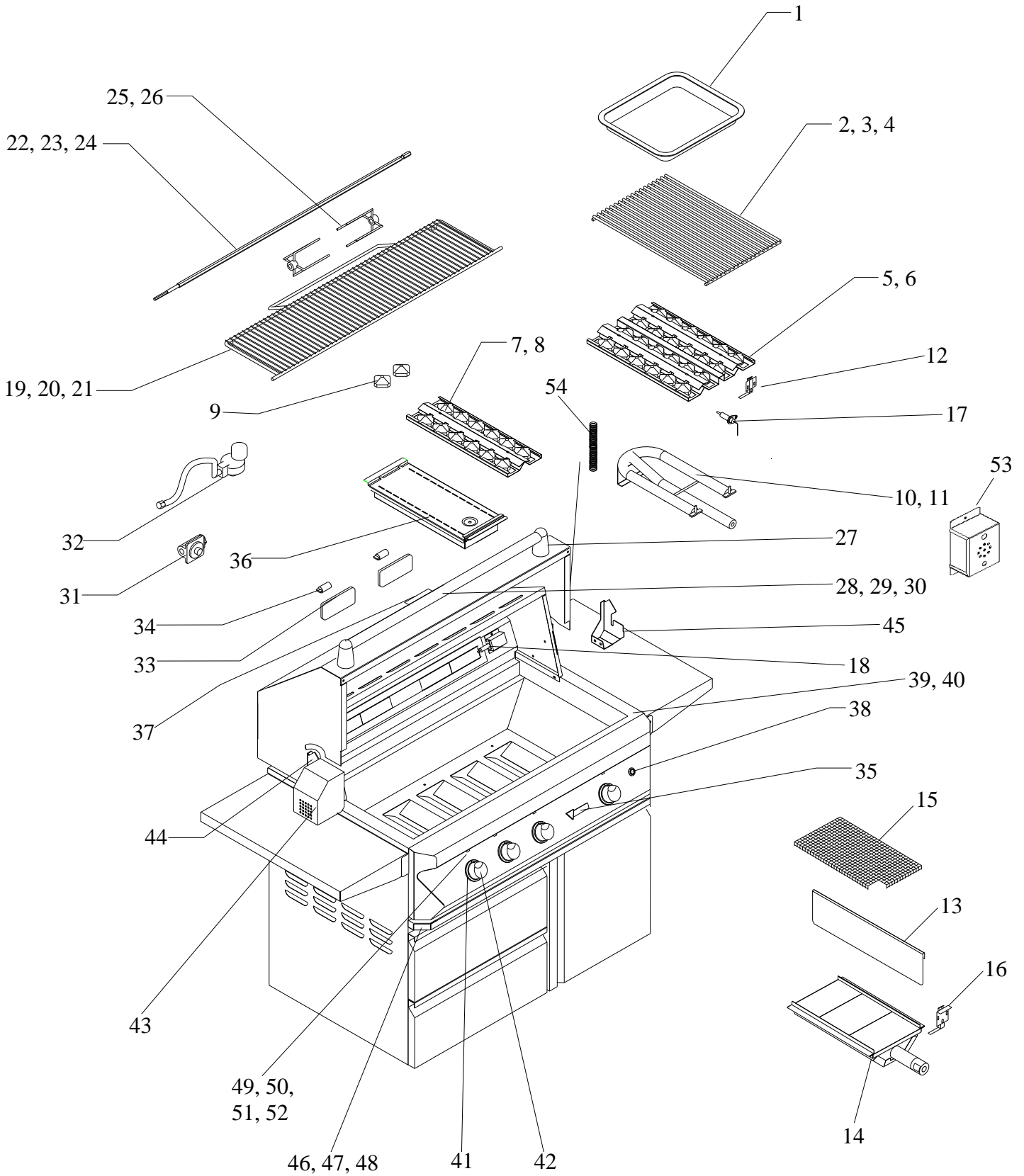

TEBQ42R with optional TEGB42SD-B Grill Base shown.

REPLACEMENT PARTS LIST – TWIN EAGLES GAS GRILL

Item No.	TE Part Number	Description	TEBQ 30G	TEBQ 30R	TEBQ 36G	TEBQ 36R	TEBQ 42G	TEBQ 42R
1	S 14421	Basting Pan		1		1		1
2	S 13801	13" Stainless Steel Hex Grate	2	2			2	2
3	S 13802	12" Stainless Steel Hex Grate					1	1
4	S 13873	10 ^{9/16} " Stainless Steel Hex Grate			3	3		
5	S 21753Y	12" Briquette Tray Assembly complete with briquettes (Standard grill)	1	1			2	2
	S 21753Y	12" Briquette Tray Assembly complete with briquettes (Grill w/ Sear Zone) Optional					1	1
6	S 21759 Y	10" Briquette Tray Assembly complete with briquettes (Standard grill)			2	2		
7	S 21761 Y	4 1/2" Briquette Tray Assembly complete with briquettes (Grill w/ Sear Zone) Optional			2	2		
8	S 21752Y	6" Briquette Tray Assembly complete with briquettes	2	2			2	2
9	S 13129	Briquettes Only	(48)	(48)	(72)	(72)	(72)	(72)
10	S 13301	Stainless Steel U6-burner (0.75 in. wall)	2	2			3	3
11	S 13350	Stainless Steel U5-burner (0.75 in. wall)			3	3		
12	S 21750Y	Flash Tube, (For standard U-Burners ONLY)	2	2	3	3	3	3
13	S 21743	Zone Divider	1	1	2	2	2	2
14	S 13345	Sear Zone Burner (For optional Sear Zone Burners ONLY)	1	1	1	1	1	1
15	S 13144	Screen Mesh (For optional Sear Zone Burners ONLY)	1	1	1	1	1	1
16	S 21765	Flash Tube, (For optional Sear Zone Burners ONLY)	1	1	1	1	1	1
17	S 16177-B	Hot surface igniter, Main Burner	2	2	3	3	3	3
18	S 16230	Hot surface igniter, Rotisserie Burner		1		1		1
19	S 13833	Warming Rack (30") (s/s)	1	1				
20	S 13867	Warming Rack (36") (s/s)			1	1		
21	S 13834	Warming Rack (42") (s/s)					1	1
22	S 13863	Spit Rod (30") (s/s)		1				
23	S 13868	Spit Rod (36") (s/s)				1		
24	S 13864	Spit Rod (42") (s/s), ^{9/16} "						1
25	S 13812	Meat Holder Forks (pair) (s/s), 1/2" spit rod		1		1		
26	S 13869	Meat Holder Forks (pair) (s/s), ^{9/16} " spit rod						1
27	S 13105	Bracket, Handle Chrome	2	2	2	2	2	2
28	S 12315	Hood Handle (1.25D x 18GA x 24)	1	1				
29	S 12339	Hood Handle (1.25D x 18GA x 30)			1	1		
30	S 12316	Hood Handle (1.25D x 18GA x 36)					1	1
31	S 15303	Regulator, NG (NG grill ONLY)	1	1	1	1	1	1
32	S 15302	Regulator, LP (LP grill ONLY)	1	1	1	1	1	1
33	S16240	Halogen light complete	2	2	2	2	2	2
34	S16191	Bulb, halogen light (12V/ 10W)	2	2	2	2	2	2
35	S 13147	Twin Eagles Logo	1	1	1	1	1	1
36	S 21623Y	Smoker Box Assy.	1	1	1	1	1	1
37	S 15340A	Thermometer	1	1	1	1	1	1
38	S 16196	Switch, front panel and interior lights	1	1	1	1	1	1
39	S 16194	Switch, hood	1	1	1	1	1	1
40	S 12112	Rod, hood switch	1	1	1	1	1	1
41	S 13128P	Bezel, Knob, Stainless Steel	2	3	3	4	3	4
42	S 13154	Knob, Chrome	2	3	3	4	3	4
43	S 16208Y	Rotisserie Motor with bracket (s/s)		1		1		1
44	S 21747-L	Motor Mounting Bracket (Lh)		1		1		1
45	S 21747-R	Motor Mounting Bracket (Rh) (Optional)		1		1		1
46	S 21745-3Y	Drip Pan Assy. (30")	1	1				
47	S 21745-36Y	Drip Pan Assy. (36")			1	1		
48	S 21745-4Y	Drip Pan Assy. (42")					1	1
49	S 16192	LED Holder	2	3	3	4	3	4
50	S 16198	LED Wire Harness, 30" (NOT SHOWN)	1	1				
51	S 16200	LED Wire Harness, 36" (NOT SHOWN)			1	1		
52	S 16199	LED Wire Harness, 42" (NOT SHOWN)					1	1
53	S 16233	Transformer Assembly	1	1	1	1	1	1
54	S 14226	Springs kit, hood	2	2	2	2	2	2



TROUBLESHOOTING GUIDE – TWIN EAGLES GAS GRILL

BEFORE CALLING FOR SERVICE:

If your Twin Eagles grill does not function properly, use the following troubleshooting guide before contacting your dealer for service. The troubleshooting guide may save the cost of a service call and the inconvenience of being without your grill.

PROBLEM	WHAT TO DO
Grill will not light.	<ol style="list-style-type: none"> 1. Push in the knob and verify that the igniter glow. 2. If the igniter does not glow verify proper power supply. GFCI 120V. <ol style="list-style-type: none"> a. Purge the line of any trapped air. b. Check if you can match-light the burner. c. Check to see that the other burners operate. <p>NOTE: It is normal to hear a popping sound when the grill burners are first turned ON.</p>
Burner flame is yellow and gas odor can be smelled.	<ol style="list-style-type: none"> 1. Check the burner inlet for obstruction...ex. Spiders, insects, etc. 2. Check the air shutter for proper adjustment. 3. Check any source of gas leak.
Low heat generated with knob in HI position.	<ol style="list-style-type: none"> 1. Check if the problem is isolated to only one burner. If it appears so, clean the orifice and burner, clearing ports of any obstruction. 2. Check for any bent or kinked fuel hose. 3. Check if the air shutter is properly adjusted. 4. Check for proper gas supply and pressure. 5. Pre-heat grill for 15 minutes. 6. If using LP gas, check for empty tank.
Too much heat.	<ol style="list-style-type: none"> 1. Check for damaged orifice or no orifice. 2. Check for unauthorized regulator adjustment.
Excessive flare-up.	<ol style="list-style-type: none"> 1. Check if the cooking grids are dirty. Clean if necessary. 2. Overload from fatty meats or excessive cooking temperature.
Burner blows out	<ol style="list-style-type: none"> 1. Check for any burner defect. 2. Check for proper burner installation. 3. Check if fuel mixture is too lean. 4. Check if gas supply is sufficient. 5. Check if LP tank is empty. 6. Check if the grill location is subject to high winds.
Interior light will not turn ON.	<ol style="list-style-type: none"> 1. Check if the unit is plugged into proper voltage (GFCI 120V). 2. Replacement of the light bulb may be required.
Glow igniter will not turn ON.	<ol style="list-style-type: none"> 1. Check if the unit is plugged into proper voltage (GFCI 120V).
Front panel lights will not turn ON.	<ol style="list-style-type: none"> 1. Check if the unit is plugged into proper voltage (GFCI 120V).
Thermometer is not reaching high temperatures	<ol style="list-style-type: none"> 1. Allow the grill 15 minutes with hood closed at high setting in order to reach higher temperatures.





TWIN EAGLES GRILL WARRANTY

LIMITED LIFETIME WARRANTY: Twin Eagles warrants the stainless steel main burners, hexagonal grates and all fabricated stainless steel components, to be free from defects in materials and workmanship under normal residential use for the lifetime of the product. This warranty excludes discoloration, surface scratches, weather and atmospheric related staining, and minor surface rust and oxidation which are normal conditions and to be expected with any outdoor product. The actual part will be repaired or replaced, free of charge, with the owner paying for all other costs, including labor and freight.

FIVE YEAR LIMITED WARRANTY: Twin Eagles warrants the stainless steel briquette trays, gas valves, sear zone burners, rotisserie burners and drip pans to be free from defects in materials and workmanship under normal residential use for a period of five years from the original date of purchase. The actual part will be repaired or replaced, free of charge, with the owner paying for all other costs including labor and freight.

ONE-YEAR FULL WARRANTY: Twin Eagles warrants the outdoor gas grill and all of their component parts, to be free from defects in materials and workmanship under normal residential use for a period of one year from the original date of purchase. Twin Eagles will repair or replace, at its option, any part, which fail or is found to be defective during the warranty period, at no cost to the original purchaser. Warranty service must be performed by a Twin Eagles authorized representative during normal business hours.

NINETY (90) DAY RESIDENTIAL PLUS WARRANTY: This warranty applies to applications where use of the product extends beyond normal residential use such as bed and breakfast inn and private clubs. The actual part will be repaired or replaced, free of charge, with the owner paying for all other costs including labor and freight. This warranty excludes all commercial locations such as restaurants and food service locations.

WARRANTY LIMITATIONS & EXCLUSIONS

This warranty shall apply only to the products purchased and located in the continental United States and Canada. The warranty coverage begins on the original date of purchase and proof of date of purchase is required. In order to activate the warranty, we require that you send in the attached warranty registration card. This warranty applies only to the original owner and may not be transferred.

This warranty does not apply to damages resulting from negligence, alteration, misuse, abuse, accident, natural disaster, loss of electrical power to the product for any reason, improper installation or improper operation, unauthorized adjustments or calibrations, dings, dents, scratches, or damages due to harsh cleaning chemicals. This warranty does not apply to commercial use, or to products with altered or removed serial numbers. Twin Eagles shall not be liable for incidental, consequential, special or contingent damages resulting from its breach of this written warranty or any implied warranty.

WARRANTY SERVICE & REPLACEMENT PARTS: Call your authorized selling dealer or call Twin Eagles directly at **800-789-2206**. Be prepared to furnish the following information: Purchaser's name, model and serial number of the grill, date of purchase and the accurate description of the problem. Twin Eagles will not pay for service calls for correcting an installation problem. Owner shall be responsible for proper installation, providing normal care and maintenance, providing proof of purchase upon request and making the grill accessible for service. In the event of any warranty replacement, all removal, replacement, installation and shipping costs are the responsibility of the grill owner.

Some states do not allow limitations on how long an implied warranty lasts, or the exclusions of or limitations on consequential damages. This warranty gives you specific legal rights and you may have other rights, which vary from state to state



HOW TO OBTAIN SERVICE

For service, please contact your TWIN EAGLES dealer or call TWIN EAGLES direct at (800) 789-2206 or (562) 802-3488 or fax (562) 802-3391

Mailing address:
Twin Eagles, Inc.
13231 East 166th Street
Cerritos, CA 90703

Visit us at www.twineaglesbbq.com

Please provide:

- Model number
- Serial Number
- Date of installation
- A description of the problem

Cut
Here



Warranty Registration

Customer Name	Model #
Address	Serial #
City	Date Purchased
Zip	Dealer's Name
Phone #	Dealer's Address
e-mail:	

This Warranty Registration card must be returned within thirty days of purchased to properly activate your warranty. This information is for our internal use only.

Or you may register online at <http://www.twineaglesbbq.com/contactus.shtml>



Cut
Here



Place
Postage
Here

Customer Service
ATTN: Warranty Department
13231 East 166th Street
Cerritos, CA 90703
Fax no. (562) 802-3391

