

This Owner's Manual is provided and hosted by [Appliance Factory Parts](#).



# AMANA MM-104XP Owner's Manual

[Shop genuine replacement parts for AMANA MM-104XP](#)



[Find Your AMANA Microwave Parts - Select From 149 Models](#)

----- Manual continues below -----

# ***Amana***

## **Light Duty Commercial Microwave Oven Owner's Manual**

### **LD10D2**

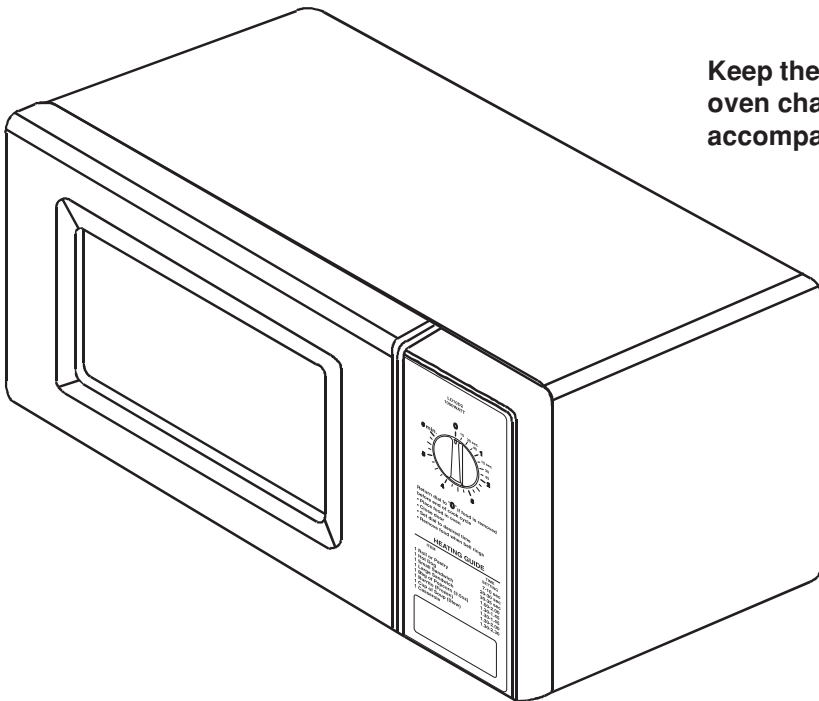

Keep these instructions for future reference. If the oven changes ownership, be sure this manual accompanies oven.

# Contents

Model Identification .....	2
Specifications .....	2
<b>IMPORTANT SAFETY INSTRUCTIONS</b>	
WARNING .....	3
WARNING .....	3
<b>PRECAUTIONS TO AVOID POSSIBLE EXPOSURE TO EXCESSIVE MICROWAVE ENERGY</b> .....	
MESURES DE SECURITE IMPORTANTES .....	5
Danger .....	5
Attention .....	5
<b>PRECAUTIONS CONTRE LES RISQUES D'EXPOSITION À UN EXCES DE MICRO-ONDES</b> .....	
Mise à la terre .....	7
Grounding Instructions .....	7
Installation .....	8
Unpacking Equipment .....	8
Radio Interference .....	8
Equipment Placement .....	8
Cooking Guidelines .....	8
How Microwave Ovens Heat Food .....	8
Food Variables .....	8
Manipulation of Foods .....	9
Microwave Utensils .....	10
Cooking Hints .....	10
Oven Features .....	11
Operation .....	12
Heating .....	12
Cleaning .....	13
Before Calling for Service .....	14
Warranty .....	15

## Model Identification

Complete enclosed registration card and promptly return. If registration card is missing, call Consumer Affairs Department at 1-800-843-0304 inside U.S.A. 1-319-622-5511 outside U.S.A.

When contacting Amana, provide product information. Product information is located on equipment serial plate. Record the following information:

Model Number: \_\_\_\_\_  
 Manufacturing Number: \_\_\_\_\_  
 Serial or S/N Number: \_\_\_\_\_  
 Date of purchase: \_\_\_\_\_  
 Dealer's name and address: \_\_\_\_\_  
 \_\_\_\_\_  
 \_\_\_\_\_

Keep a copy of sales receipt for future reference or in case warranty service is required.

## Service

Any questions or to locate an authorized servicer, call 1-800-843-0304 inside U.S.A. 1-319-622-5511 outside U.S.A. If an automated telephone system is reached, select Commercial Microwave Ovens category. Warranty service must be performed by an authorized servicer. Amana also recommends contacting an authorized servicer if service is required after warranty expires.

## Specifications

Product specifications can change at any time without notice.

Power Supply	120V AC, 60 Hz
Input Power	1450 W
Cooking Power	1000 W I.E.C. 705 of microwave power test.
Frequency	2450 MHz
Rated Current	12.5A
Overall Dimensions (WxHxD) inches	20-7/8" x 12-3/8" x 15-1/2"
Oven Cavity Dimensions (WxHxD) inches	13-9/16" x 9-5/32" x 14-3/8"
Oven Cavity Capacity	1.0 Cu. ft.
Power Cord	5 ft.

# IMPORTANT SAFETY INSTRUCTIONS



## Recognize this symbol as a SAFETY message



### WARNING

When using electrical equipment, basic safety precautions should be followed to reduce the risk of burns, electrical shock, fire, or injury to persons.

1. READ all instructions before using equipment.
2. READ AND FOLLOW the specific "PRECAUTIONS TO AVOID POSSIBLE EXPOSURE TO EXCESSIVE MICROWAVE ENERGY" on page 4.
3. This equipment **MUST BE GROUNDED**. Connect only to properly GROUNDED outlet. See "GROUNDING INSTRUCTIONS" on page 7.
4. Install or locate this equipment **ONLY** in accordance with the provided installation instructions in this manual.
5. Some products such as whole eggs and sealed containers—for example, closed glass jars are able to explode and **SHOULD NOT** be HEATED in this oven.
6. Use this equipment **ONLY** for its intended use as described in the manual. Do not use corrosive chemicals or vapors in this equipment. This type of oven is specifically designed to heat, cook or dry food. It is not designed for industrial or laboratory use.
7. As with any equipment, **CLOSE SUPERVISION** is necessary when used by CHILDREN.
8. **DO NOT** operate this equipment if it has a damaged cord or plug, if it is not working properly, or it has been damaged or dropped.
9. This equipment, including power cord, must be serviced **ONLY** by qualified service personnel. Special tools are required to service equipment. Contact nearest authorized service facility for examination, repair, or adjustment.
10. **DO NOT** cover or block any openings on the equipment.
11. **DO NOT** store this equipment outdoors. **DO NOT** use this product near water – for example, near a kitchen sink, in a wet basement, near a swimming pool, or similar location.
12. **DO NOT** immerse cord or plug in water.
13. Keep cord **AWAY** from HEATED surfaces.
14. **DO NOT** let cord hang over edge of table or counter
15. See door cleaning instructions in "Cleaning" section of manual on page 13.
16. For commercial use only.
17. Liquids such as water, coffee, or tea are able to be overheated beyond the boiling point without appearing to be boiling due to surface tension of the liquid. Visible bubbling or boiling when the container is removed from the microwave oven is not always present. **THIS COULD RESULT IN VERY HOT LIQUIDS SUDDENLY BOILING OVER WHEN A SPOON OR OTHER UTENSIL IS INSERTED INTO THE LIQUID.** To reduce the risk of injury to persons; 1) Do not overheat the liquid. 2) Stir the liquid both before and halfway through heating it. 3) Do not use straight-sided containers with narrow necks. 4) After heating, allow the container to stand in the microwave oven for a short time before removing the container. 5) Use extreme care when inserting a spoon or other utensil into the container.



### WARNING

To reduce the risk of fire in the oven cavity:

- a. **DO NOT** overcook food. Carefully attend equipment when paper, plastic, or other combustible materials are placed inside the oven to facilitate cooking.
- b. Remove wire twist-ties from paper or plastic bags before placing bag in oven.
- c. If materials inside the oven ignite, **KEEP** oven **DOOR CLOSED**, turn oven off, and disconnect the power cord, or shut off power at the fuse or circuit breaker panel. Fire may spread if door is opened.
- d. **DO NOT** use the cavity for storage. **DO NOT** leave paper products, cooking utensils, or food in the cavity when not in use.

## SAVE THESE INSTRUCTIONS

# **PRECAUTIONS TO AVOID POSSIBLE EXPOSURE TO EXCESSIVE MICROWAVE ENERGY**

- |                                                                                                                                                                                                                                                                                                                                                               |                                                                                                                                                                                                                                                                                                                                                                     |
|---------------------------------------------------------------------------------------------------------------------------------------------------------------------------------------------------------------------------------------------------------------------------------------------------------------------------------------------------------------|---------------------------------------------------------------------------------------------------------------------------------------------------------------------------------------------------------------------------------------------------------------------------------------------------------------------------------------------------------------------|
| <p>a. DO NOT attempt to operate this oven with the door open since open-door operation can result in harmful exposure to microwave energy. It is important not to defeat or tamper with the safety interlocks.</p> <p>b. DO NOT place any object between the oven front face and door or allow soil or cleaner residue to accumulate on sealing surfaces.</p> | <p>c. DO NOT operate the oven if it is damaged. It is particularly important that the oven door close properly and that there is no damage to the : (1) door (bent), (2) hinges and latches (broken or loosened), (3) door seals and sealing surfaces.</p> <p>d. Oven should NOT be adjusted or repaired by anyone except properly qualified service personnel.</p> |
|---------------------------------------------------------------------------------------------------------------------------------------------------------------------------------------------------------------------------------------------------------------------------------------------------------------------------------------------------------------|---------------------------------------------------------------------------------------------------------------------------------------------------------------------------------------------------------------------------------------------------------------------------------------------------------------------------------------------------------------------|

## **IMPORTANT SAFETY INSTRUCTIONS**

### **CAUTION**

To avoid personal injury or property damage, observe the following:

1. Briskly stir or pour liquids before heating with microwave energy to prevent spontaneous boiling or eruption. Do not overheat. If air is not mixed into a liquid, liquid can erupt in oven or after removal from oven.
2. Do not deep fat fry in oven. Fat could overheat and be hazardous to handle.
3. Do not cook or reheat eggs in shell or with an unbroken yolk using microwave energy. Pressure may build up and erupt. Pierce yolk with fork or knife before cooking.
4. Pierce skin of potatoes, tomatoes, and similar foods before cooking with microwave energy. When skin is pierced, steam escapes evenly.
5. Do not operate equipment without load or food in oven cavity.
6. Use only popcorn in packages designed and labeled for microwave use. Popping time varies depending on oven wattage. Do not continue to heat after popping has stopped. Popcorn will scorch or burn. Do not leave oven unattended.
7. Do not use regular cooking thermometers in oven. Most cooking thermometers contain mercury and may cause an electrical arc, malfunction, or damage to oven.
8. Do not heat baby bottles in oven.
9. Do not use metal utensils in oven.
10. Never use paper, plastic, or other combustible materials that are not intended for cooking.
11. When cooking with paper, plastic, or other combustible materials, follow manufacturer's recommendations on product use.
12. Do not use paper towels which contain nylon or other synthetic fibers. Heated synthetics could melt and cause paper to ignite.
13. Do not heat sealed containers or plastic bags in oven. Food or liquid could expand quickly and cause container or bag to break. Pierce or open container or bag before heating.
14. To avoid pacemaker malfunction, consult physician or pacemaker manufacturer about effects of microwave energy on pacemaker.

## **SAVE THESE INSTRUCTIONS**

# MESURES DE SECURITE IMPORTANTES



Ce symbole signale un message de SECURITE



## DANGER

Lors de l'utilisation d'appareils électriques, prendre les précautions élémentaires suivantes pour réduire les risques de brûlures, d'électrocution, d'incendie ou de blessures.

1. **LIRE** la totalité des instructions avant d'utiliser le four.
2. **LIRE ET SUIVRE** les **PRECAUTIONS CONTRE LES RISQUES D'EXPOSITION A UN EXCES DE MICRO-ONDES**, page 6.
3. Ce four **DOIT ETRE MIS A LA TERRE**. Le brancher uniquement sur une prise correctement reliée à la terre. Voir les **INSTRUCTIONS DE MISE A LA TERRE**, page 7.
4. Mettre en service ou placer ce four **UNIQUEMENT** tel qu'indiqué dans les instructions de mise en service fournies dans ce manuel.
5. Certains aliments ou articles comme les oeufs et les récipients fermés hermétiquement tels que les bocaux, par exemple, peuvent exploser et **NE DOIVENT PAS ETRE UTILISES** dans ce four.
6. Utiliser ce four **UNIQUEMENT** pour les usages pour lesquels il est prévu, décrits dans ce manuel. Ne pas utiliser de vapeurs ni de produits chimiques corrosifs dans cet appareil. Ce type de four est spécifiquement conçu pour faire chauffer ou cuire les aliments. Il n'est pas prévu pour un usage industriel ou en laboratoire.
7. Comme pour tout autre appareil électrique, l'utilisation de cet appareil par les **ENFANTS** doit se faire **SOUS ETROITE SURVEILLANCE**.
8. **NE PAS** utiliser le four si la prise ou le cordon électrique est abîmé, si le four ne fonctionne pas correctement ou si l'appareil est tombé ou a été endommagé.
9. Cet appareil, cordon électrique compris, doit être réparé **UNIQUEMENT** par un technicien qualifié. Des outils spéciaux sont nécessaires à cette fin. Contacter le prestataire de service après-vente agréé le plus proche pour le faire examiner, réparer ou régler.
10. **NE PAS** couvrir ni boucher le filtre ni aucun orifice du four.
11. **NE PAS** placer cet appareil à l'extérieur. **NE PAS** l'utiliser près d'un endroit où il y a de l'eau, comme dans un sous-sol humide, près d'un évier ou d'une piscine ou en tout autre endroit similaire.
12. **NE PAS** plonger le cordon électrique ou la prise dans l'eau.
13. Garder le cordon électrique **A DISTANCE SURE** de surfaces **CHAUFFEES**.
14. **NE PAS** laisser le cordon pendre d'une table ou d'un comptoir.
15. Voir la marche à suivre pour l'entretien de la porte sous "*Entretien de l'extérieur du four*" dans la partie "*Entretien*" du manuel, page 13.
16. **Pour usage commercial uniquement.**



## ATTENTION

Pour réduire les risques d'incendie à l'intérieur du four :

- a. **NE PAS** trop cuire les aliments. Surveiller attentivement la cuisson si du papier, du plastique ou tout autre matériau combustible est utilisé pour faciliter la cuisson.
- b. Enlever toute attache métallique servant à fermer les sacs en plastique ou en papier avant de placer le sac dans le four.
- c. Si le feu prend dans le four, **LAISSER LA PORTE** du four **FERMEE**, éteindre le four et le débrancher ou couper le courant au niveau du fusible ou du disjoncteur. Si la porte du four est ouverte, l'incendie peut se propager.
- d. **NE PAS** utiliser l'intérieur du four comme espace de rangement. **NE PAS** laisser d'articles en papier, de récipients, d'ustensiles de cuisson nid'aliments dans le four pendant qu'il n'est pas utilisé.

# CONSERVER CES INSTRUCTIONS

# PRECAUTIONS CONTRE LES RISQUES D'EXPOSITION À UN EXCES DE MICRO-ONDES

- |                                                                                                                                                                                                                                                     |                                                                                                                                                                                                                                                                                                                                     |
|-----------------------------------------------------------------------------------------------------------------------------------------------------------------------------------------------------------------------------------------------------|-------------------------------------------------------------------------------------------------------------------------------------------------------------------------------------------------------------------------------------------------------------------------------------------------------------------------------------|
| a. <b>NE PAS</b> essayer de faire fonctionner le four avec la porte ouverte car cela peut entraîner une exposition dangereuse aux micro-ondes. Il est important de ne pas modifier les verrouillages de sécurité ni d'entraver leur fonctionnement. | c. <b>NE PAS</b> utiliser le four s'il est endommagé. Il est particulièrement important que sa porte ferme correctement et que les éléments suivants ne soient pas endommagés : (1) porte (faussée), (2) charnières et dispositifs de verrouillage (cassés ou présentant du jeu), (3) joints de la porte et surfaces formant joint. |
| b. <b>NE PAS</b> placer d'objet entre le cadre avant du four et la porte ni laisser de saletés ou de résidus de produit nettoyant s'accumuler sur les surfaces formant joint.                                                                       | d. Ce four ne doit <b>PAS</b> être réglé ni réparé par une personne autre qu'un technicien de service après-vente dûment qualifié.                                                                                                                                                                                                  |

## MESURES DE SECURITE IMPORTANTES



### ATTENTION

Pour éviter tous dégâts matériels ou blessures, observer les consignes suivantes :

1. Pour éviter toute ébullition ou éruption spontanée, remuer vigoureusement ou verser les liquides avant de les chauffer au four à micro-ondes. Ne pas trop chauffer. Si de l'air n'a pas été incorporé dans le liquide, celui-ci peut déborder dans le four ou après en avoir été retiré.
2. Ne pas faire de friture dans le four. La graisse pourrait surchauffer et devenir dangereuse à manipuler.
3. Les oeufs ne doivent pas être chauffés ou réchauffés au four à micro-ondes dans leur coquille ou avec leur jaune intact ; cela pourrait provoquer une accumulation de pression et l'éclatement de l'oeuf. Percer le jaune avec une fourchette ou un couteau avant la cuisson.
4. Percer la peau des pommes de terre, tomates et aliments similaires avant de les cuire au four à micro-ondes. Lorsque la peau est percée, la vapeur peut s'échapper uniformément.
5. Ne pas faire fonctionner l'appareil sans nourriture à l'intérieur.
6. Pour faire du pop-corn, utiliser uniquement du maïs en paquet spécial micro-ondes (indiqué sur l'étiquette). Le temps nécessaire pour faire éclater le maïs varie en fonction de la puissance du four. Ne pas continuer à faire chauffer le maïs une fois qu'il a fini d'éclater, car il peut brûler ou s'enflammer. Ne pas laisser le four sans surveillance.
7. Ne pas utiliser de thermomètre de cuisson pour four traditionnel dans le four. La plupart des thermomètres de cuisson contiennent du mercure qui peut causer des arcs électriques ou le mauvais fonctionnement du four, ou encore endommager celui-ci.
8. Ne pas faire chauffer de biberon au four.
9. Ne pas utiliser d'ustensiles métalliques dans le four.
10. Ne jamais utiliser de papier, de plastique ni autre matériau combustible non prévu pour la cuisson.
11. Si la cuisson utilise du papier, du plastique ou autre matériau combustible, suivre les recommandations du fabricant concernant son utilisation.
12. Ne pas utiliser de serviettes en papier contenant du nylon ou autres fibres synthétiques. Ces fibres pourraient fondre et faire enflammer le papier.
13. Ne pas faire chauffer de récipients ni de sacs en plastique hermétiquement fermés dans le four. La nourriture ou le liquide pourrait gonfler rapidement et faire éclater le récipient ou le sachet. Percer ou ouvrir celui-ci avant de le faire chauffer.
14. Pour éviter toute défaillance de stimulateur cardiaque, prière de se renseigner auprès du médecin ou du fabricant du stimulateur au sujet des effets de l'énergie micro-ondes sur ce dispositif.

## CONSERVER CES INSTRUCTIONS

## Mise à la terre



### DANGER

Pour éviter tout risque d'électrocution, voire de décès, cet appareil doit être relié à la terre.



### DANGER

Pour éviter tout risque d'électrocution, voire de décès, ne pas modifier la fiche.

Cet appareil **DOIT** être relié à la terre. En cas de court-circuit, la mise à la terre réduit les risques d'électrocution en permettant au courant électrique de passer par un fil. Ce four est muni d'un cordon équipé d'un fil de mise à la terre avec une fiche de mise à la terre. La fiche doit être branchée dans une prise correctement installée et mise à la terre.

Consulter un électricien ou un prestataire de service qualifié si les instructions de mise à la terre ne sont pas bien comprises ou si un doute subsiste quant à la mise à la terre correcte de l'équipement.

Ne pas utiliser de rallonge. Si le cordon d'alimentation de l'appareil est trop court, demander à un électricien d'installer une prise de courant à trois trous. Ce four doit être branché sur un circuit indépendant de 60 Hz dont la puissance nominale est indiquée sur l'illustration correspondante. Ce modèle nécessite une tension d'alimentation de 120V. Lorsqu'un four à micro-ondes est branché sur un circuit avec d'autres appareils, les temps de cuisson pourront être prolongés et des fusibles pourraient sauter.

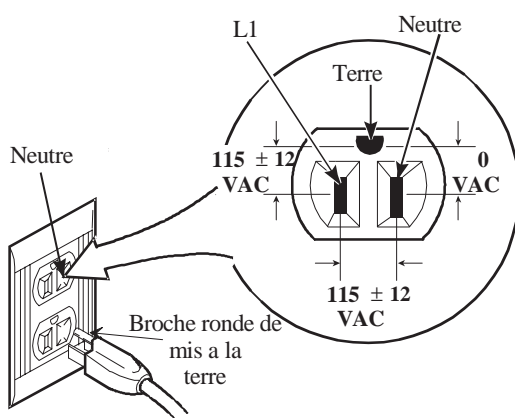

NEMA 5-15P/5-15R  
120V-15AMP

Fiche de mise à la terre

## Grounding Instructions



### WARNING

To avoid risk of electrical shock or death, this equipment must be grounded.



### WARNING

To avoid risk of electrical shock or death, do not alter the plug.

This equipment **MUST** be grounded. In the event of an electrical short circuit, grounding reduces the risk of electric shock by providing an escape wire for the electric current. This oven is equipped with a cord having a grounding wire with a grounding plug. The plug must be plugged into an outlet that is properly installed and grounded.

Consult a qualified electrician or servicer if grounding instructions are not completely understood, or if doubt exists as to whether the equipment is properly grounded.

Do not use an extension cord. If the product power cord is too short, have a qualified electrician install a three-slot receptacle. This oven should be plugged into a separate 60 hertz circuit with the electrical rating as shown in the appropriate drawing. This model requires a 120 supply voltage. When a microwave oven is on a circuit with other equipment, an increase in cooking times may be required and fuses can be blown.

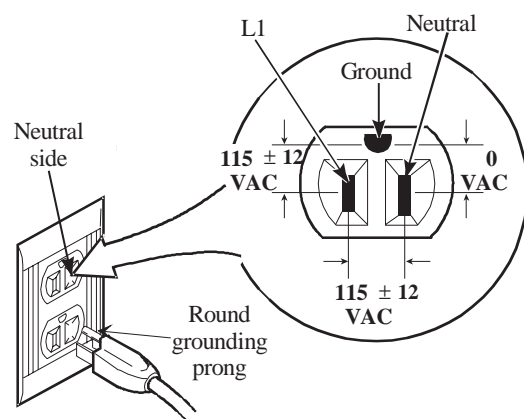

NEMA 5-15P/5-15R  
120V-15AMP

Grounded Receptacle and Plug

# Installation

## Unpacking Equipment

- Inspect equipment for damage such as dents in door or dents inside oven cavity.
- Report any dents or breakage to source of purchase immediately. Do not attempt to use oven if damaged.
- Remove all materials from oven interior.
- If oven has been stored in extremely cold area, wait a few hours before connecting power.

## Radio Interference

Microwave operation may cause interference to radio, television, or similar equipment. Reduce or eliminate interference by doing the following:

- Clean door and sealing surfaces of oven according to instructions in "Care and Cleaning" section.
- Place radio, television, etc. as far as possible from oven.
- Use a properly installed antenna on radio, television, etc. to obtain stronger signal reception.

## Equipment Placement

- Do not install equipment next to or above source of heat, such as a deep fat fryer. This could cause microwave oven to operate improperly and could shorten life of electrical parts.
- Do not block or obstruct oven filter. Allow access for cleaning.
- Install oven on level countertop surface.

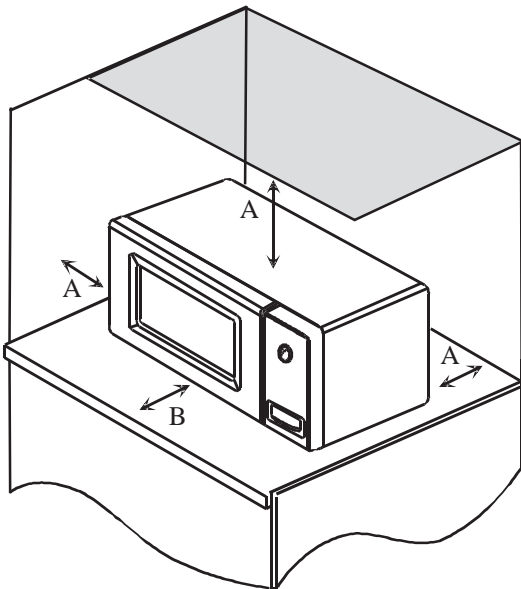

A—Allow at least 3 inches (7.62 centimeters) of clearance around top and sides of equipment. Proper air flow around equipment cools electrical components. With restricted air flow, oven may not operate properly and life of electrical parts is reduced.

B—Allow at least 3 inches from door front to edge of countertop to avoid accidental tipping of oven.

Oven Clearances

# Cooking Guidelines

The Amana Microwave Oven can make your job easier. You'll cook ahead and pre-portion more. You'll also spend less time preparing special-order dishes.

To be sure of consistently good results, remember a few simple guidelines.

## How Microwave Ovens Heat Food

All food and liquid molecules have positive and negative particles which are in constant, but slow, motion. (Positive and negatives attract and repel each other like magnets.) In microwave cooking this molecular action is then accelerated. The instant microwaves bombard food they agitate the molecules. Agitation causes friction as molecules rub and bump into each other at an increased rate. Friction results in heat that cooks food and boils water.

Once the microwaves stop, this friction action continues by itself, eventually tapering off and returning to normal molecular action.

Microwaves penetrate food to a short depth. As cooking begins, heat is spread by conduction to the interior portion of the food just as in conventional cooking methods.

## Food Variables

Microwave cooking can be directly affected by different food variables.

The **shape** of foods can greatly affect the amount of cooking time. Foods that are flat and thin heat faster than foods which are chunky. For example, a casserole will cook faster in a flat dish, rather than if heaped in a small dish. Foods cut into small pieces will cook faster than large-shaped foods. Pieces should be of a uniform size and shape for more uniform cooking, or the smaller pieces will cook faster. The greatest amount of heating takes place near the food's surface. The interior of large food items, or dense foods, is heated by the heat conducted from the outer food layer. The most uniform heating occurs in flat, doughnut-shaped foods. For best results, cook foods together which have similar sizes and shapes.

---

The **quantity** or volume of a food can affect the amount of cooking time. As the volume of the food is increased, the time required to cook or heat the item increases almost proportionately. If twice the amount of food is placed in the oven, it will take almost twice as long to cook. To determine the time for larger quantities, multiply the individual serving time by the increased amount, then reduce the total heating time by about 20%.

The **density** of foods can greatly affect the amount of cooking time. Porous foods, such as breads, cakes or pastries, will heat much more quickly than dense meats of the same size. Porous foods absorb microwaves quickly throughout. Meats absorb microwaves mostly at the exterior surface, and the interior is heated by conduction, increasing the cooking time. Meats can be cooked in a sauce, if desired. Due to the moisture content, a sauce will heat rapidly. The heat will transfer to the meat, so the meat will heat faster due to heat by conduction as well as by microwaves.

The **starting temperature** of foods affects the amount of cooking time. Each temperature degree that the food item is to raise must be supplied with a definite amount of energy. Lower initial starting temperatures require more energy and more time to cook. Therefore, refrigerator temperature foods require a longer cooking time than room temperature foods. Foods already slightly warm will heat very quickly in the oven.

The **moisture content** of foods affects the amount of cooking time. The higher the moisture content is in a food the longer the amount of cooking time.

The **fat and sugar content** of foods affects the amount of cooking time. Foods containing high fat and sugar levels heat very quickly and may reach much higher temperatures than foods having low fat and sugar levels. Foods having lower fat and sugar levels require longer cooking times.

The **arrangement** of food within a microwave oven cavity affects the way in which the food cooks. A “round” arrangement is best. Use round utensils whenever possible. Also, arrange foods such as baked potatoes in a circle, rather than in rows, for cooking. When only one food item is being cooked, place it in the center of the oven glass shelf for cooking.

## Manipulation of Foods

Sometimes recipes suggest manipulating or moving food during cooking. There are several forms of manipulation:

**Stirring** is required less often in microwave cooking than in conventional cooking. In conventional cooking, you use a spoon to move food up from the bottom of a pan to evenly distribute the heat. In microwave cooking, you still stir to redistribute the heat within some foods, but you need to stir from the outside of a dish toward the inside or center. If a recipe states to stir once or twice during cooking, stir at approximately even intervals. For example, in a 12-minute cooking period, if a recipe states to stir twice, stir after 4 minutes of cooking and again, after 8 minutes of cooking. However, it is not necessary to be precise. Stir only when necessary. When using lower power levels or settings, less stirring is required. Some examples of foods which may require stirring are puddings, some casseroles, some sauces, some soups, and some egg dishes. Some foods can't be stirred. These foods are rearranged or turned.

Some foods can't be stirred and should be **repositioned or rearranged** during cooking. Some examples include baked potatoes, cupcakes (in custard cups), and chicken pieces. Rearranging allows for more even cooking of foods. Foods which are cooked, covered or which are cooked using lower power levels, usually require little rearranging.

**Turning foods over:** Turning foods over is done to distribute heat. Meat and poultry are two types of foods which are sometimes “turned over.” Examples include roasts, turkeys and whole chickens. Small meat items such as poultry pieces may need to be turned over when in casseroles, or when in a browning skillet.

## Microwave Utensils



### CAUTION

To avoid burns, use protective gloves or pads when removing dishes from oven. Some utensils become hot while cooking.

Never use cooking containers or covers with any metal content. This includes all metal and enameled metal-core ware, foil, and metal-trimmed containers. Suitable heating containers include those made of paper products, glass, china, cloth, and wicker baskets.

Recommended	Not Recommended
Glass/ceramic	Aluminum foil
Natural fiber cloth	Grocery bags
Non-recycled paper	Recycled paper
Plastic	Lead crystal
Wood	Newspapers
	Metal
	Metallic trimmed china

### Utensil Check Test

Use the following test to check utensils for microwave safeness.

1. Place glass measuring cup of water next to empty dish to be tested in microwave oven.
2. Heat on full power for one minute.
3. Check temperature of dish and water.
  - If dish remains cool and water is hot, dish is microwave safe.
  - If dish is slightly warm, use for short term cooking.
  - If dish is hot and water is cool, do not use. Dish remains cool if not absorbing microwaves and microwaves are being absorbed by water. Dish becomes hot if absorbing microwaves.

## Cooking Hints

**Cover foods for faster, more even heating.** Glass lids, plastic wrap, plate covers or other paper products may be used. Do not seal. Instead, allow for steam-venting at all times.

**Pierce pouches, plastic wrap covers and all foods** with a thin skin or membrane, such as potatoes, squash, tomatoes, eggs, etc. This prevents an eruption in the oven and allows for expansion and/or the escape of steam.

**Foods should be carefully arranged.** For best results, arrange food such as vegetables or casserole-type items evenly around the edge of the plate with slightly less depth in the center. The edges of food items should not overlap or overhang the rim of the container. Cover meats with gravy or au jus and moisten all dry foods other than bread or pastry items.

**Do not stack food or plated dishes in your oven.** Instead, when heating more than one serving or platters, all plates should be placed at the same level in the oven, with space between all containers.

# Oven Features

---

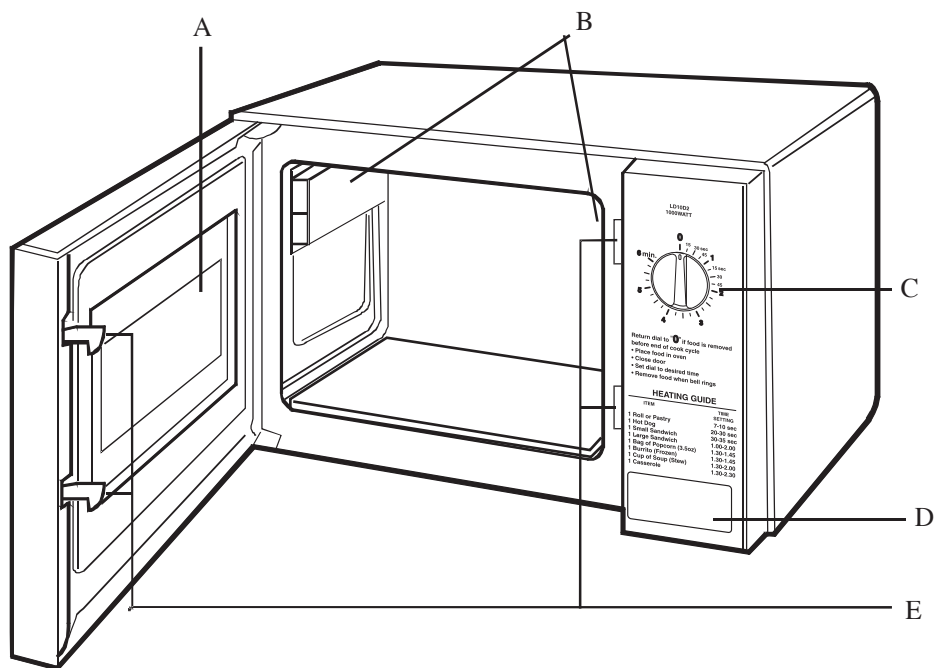

- A—Window Door Screen
- B—Splatter Shields
- C—Timer Knob
- D—Door Open Button
- E—Safety Door Lock System

---

Oven Features

# Operation

## Heating



### CAUTION

To avoid fire, do not dry newspapers or clothes in microwave oven.

1. Open oven door, place food in oven and close door.
2. Set timer knob to desired cooking time by turning clockwise.
  - Turn timer knob slightly past, and then back to desired cooking time for the most accurate time setting.
  - Heating begins.
3. When time has elapsed, signal sounds and oven shuts off.

### Pausing or Stopping Operation

1. Open oven door.
  - Oven stops heating.
  - Timer maintains current time setting.
2. Heating resumes when door is closed.
3. Turn timer knob counterclockwise to "0" to clear all cooking time.

LD10D2  
1000WATT

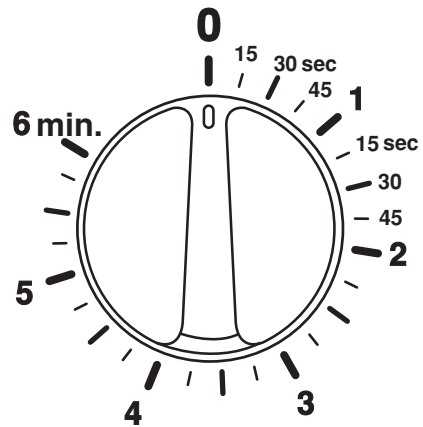

Return dial to "0" if food is removed before end of cook cycle

- Place food in oven
- Close door
- Set dial to desired time
- Remove food when bell rings

### HEATING GUIDE

ITEM	TIME SETTING
1 Roll or Pastry	7-10 sec
1 Hot Dog	20-30 sec
1 Small Sandwich	30-35 sec
1 Large Sandwich	1.00-2.00
1 Bag of Popcorn (3.5oz)	1.30-1.45
1 Burrito (Frozen)	1.30-1.45
1 Cup of Soup (Stew)	1.30-2.00
1 Casserole	1.30-2.30

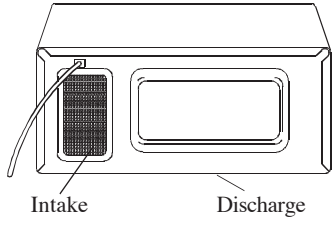

# Cleaning

Part	Description
Interior, Exterior, and Door	<p>Clean microwave oven with mild detergent in warm water using soft sponge or cloth. Wring sponge or cloth to remove excess water before wiping equipment. If desired, boil a cup of water in microwave oven to loosen soil before cleaning.</p> <p><b>Important:</b></p> <ul style="list-style-type: none"> <li>• Do not use abrasive cleansers or cleaners containing ammonia. These could damage finish.</li> <li>• Never pour water into microwave oven bottom.</li> <li>• Do not use water pressure type cleaning systems.</li> </ul>
Discharge Air Vents 	<p>Check monthly for a buildup of cooking vapors along intake and discharge louvers on bottom and back of oven. Clean air vents with damp cloth to ensure proper airflow. Dry thoroughly.</p>
Control Panel	<p>Open oven door to deactivate oven timer. Clean with mild detergent in warm water using soft sponge or cloth.</p>
Splatter Shields	<p>Splatter shields can be cleaned in place or removed. Clean with mild detergent in warm water using soft sponge or cloth.</p> <p>Splatter shields are held in place with (3) screws. If desired, remove splatter shields for cleaning by removing screws. Replace splatter shields before using oven.</p>

## Before Calling for Service

---

Record all inspections and repair for future reference.



### WARNING

To avoid electrical shock which can cause severe personal injury or death, do not remove outer case at any time. Only an authorized servicer should remove outer case.

Symptom	Check
If oven does not operate:	<ul style="list-style-type: none"><li>• Check fuse or circuit breaker.</li><li>• Confirm oven is plugged into dedicated circuit.</li><li>• Confirm oven is on grounded and polarized circuit. Contact electrician to confirm.</li></ul>
If oven light does not work:	<ul style="list-style-type: none"><li>• Oven light must be replaced by a servicer.</li></ul>
If oven operates intermittently:	<ul style="list-style-type: none"><li>• Check air discharge area for obstructions.</li></ul>
Oven operates, but does not heat food:	<ul style="list-style-type: none"><li>• Place one cup cool water in oven. Heat for one minute. If water temperature does not rise, oven is operating incorrectly and a servicer should be called.</li></ul>

Any questions or to locate an authorized servicer, call 1-800-843-0304 inside U.S.A. 1-319-622-5511 outside U.S.A. If an automated telephone system is reached, select Commercial Microwave Ovens category. Warranty service must be performed by an authorized servicer. Amana also recommends contacting an authorized servicer if service is required after warranty expires.



# Commercial Microwave Oven Warranty AMENDMENT

*Applies to units produced in March 2002 (serial number 10100001AE) and forward.*

**Amana Appliances warrants this product when the original purchaser uses the oven for commercial food service preparation.**

## Limited ONE Year Warranty

### First Year

Amana Appliances will replace any part (f.o.b. Amana, Iowa, U.S.A.), except for the oven cavity teflon coating or glass turntable (if applicable), which has failed due to workmanship or materials.

## Limited THREE Year Warranty

### Second Through Third Year

Amana Appliances will replace any electrical part (f.o.b. Amana, Iowa, U.S.A.) which has failed due to workmanship or materials.

## OWNER'S RESPONSIBILITIES:

- Provide proof of purchase
- Provide normal care and maintenance, including cleaning as instructed in owner's manual.
- Make product accessible for service.
- Pay for premium service costs for service outside servicer's normal business hours.
- Pay for service calls related to product installation and customer education.
- Provide any defective part to an authorized Amana Servicer.
- Replace owner replaceable items where directions appear in the Owner's Manual.

## ITEMS NOT COVERED:

- Teflon coating in oven cavity interior (if applicable)
- Glass or ceramic turntable (if applicable)
- Normal product maintenance and cleaning.
- Lost or broken air filters.
- Light bulbs
- Lost or broken grease shields.
- Damages which occur in shipment.
- Broken ceramic shelves
- General rebuilding or refurbishing
- Failures caused by:
  - Unauthorized service
  - Grease or other material buildup due to improper cleaning or maintenance.
  - Accidental or intentional damage.
  - Connection to an improper power supply.
  - Acts of God.
  - Operating an empty oven.
  - Use of improper pans, containers, or accessories that cause damage to the product.

## WARRANTY LIMITATIONS:

- Begins at date of original purchase.
- Applies to product used for NORMAL commercial food preparation.
- Service must be performed by an authorized Amana Servicer.
- Applies to product used within the United States or in Canada if product has appropriate agency listing when shipped from the factory.
- Damage due to shipping and handling is not covered.
- V.A.T, duties, customs fees, and other related expenses are not covered by this warranty.

## WARRANTY IS VOID IF:

- Serial plate is defaced.
- Product is altered by user.
- Product is not installed or used according to manufacturer's instructions.

## IN NO EVENT SHALL AMANA APPLIANCES BE LIABLE FOR INCIDENTAL OR CONSEQUENTIAL DAMAGES\*

This warranty gives you specific legal rights and you may have others from state to state. For example, some states do not allow the exclusion or limitation of incidental or consequential damages so this exclusion may not apply to you.

For answers to questions regarding the above, contact equipment supplier or;

Amana Commercial Products  
2800 220th Trail PO Box 8901  
Amana, Iowa 52204-0001  
1-800-843-0304 inside U.S.A.  
1-319-622-5511 outside U.S.A.

